

# Service Manual

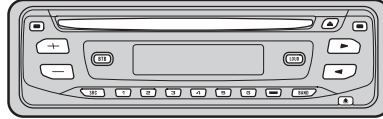

DEH-1700/XN/UC

ORDER NO.  
**CRT3376**

HIGH POWER CD PLAYER WITH FM/AM TUNER

# DEH-1700 /XN/UC

## DEH-7 /XN/UC

This service manual should be used together with the following manual(s):

Model No.	Order No.	Mech.Module	Remarks
CX-3110	CRT3178	S10.1	CD Mech. Module:Circuit Description, Mech. Description, Disassembly



For details, refer to "Important Check Points for Good Servicing".

# SAFETY INFORMATION

## CAUTION

This service manual is intended for qualified service technicians; it is not meant for the casual do-it-yourselfer. Qualified technicians have the necessary test equipment and tools, and have been trained to properly and safely repair complex products such as those covered by this manual. Improperly performed repairs can adversely affect the safety and reliability of the product and may void the warranty. If you are not qualified to perform the repair of this product properly and safely, you should not risk trying to do so and refer the repair to a qualified service technician.

## WARNING

This product contains lead in solder and certain electrical parts contain chemicals which are known to the state of California to cause cancer, birth defects or other reproductive harm.  
Health & Safety Code Section 25249.6 - Proposition 65

### ● Service Precaution



1. You should conform to the regulations governing the product (safety, radio and noise, and other regulations), and should keep the safety during servicing by following the safety instructions described in this manual.
2. Before disassembling the unit, be sure to turn off the power. Unplugging and plugging the connectors during power-on mode may damage the ICs inside the unit.
3. To protect the pickup unit from electrostatic discharge during servicing, take an appropriate treatment (shorting-solder) by referring to "the DISASSEMBLY".
4. After replacing the pickup unit, be sure to check the grating.

**COMPACT**  
**disc**  
**DIGITAL AUDIO**

## [Important Check Points for Good Servicing]

In this manual, procedures that must be performed during repairs are marked with the below symbol. Please be sure to confirm and follow these procedures.

### 1. Product safety



Please conform to product regulations (such as safety and radiation regulations), and maintain a safe servicing environment by following the safety instructions described in this manual.

- ① Use specified parts for repair.

Use genuine parts. Be sure to use important parts for safety.

- ② Do not perform modifications without proper instructions.

Please follow the specified safety methods when modification (addition/change of parts) is required due to interferences such as radio/TV interference and foreign noise.

- ③ Make sure the soldering of repaired locations is properly performed.

When you solder while repairing, please be sure that there are no cold solder and other debris. Soldering should be finished with the proper quantity. (Refer to the example)

- ④ Make sure the screws are tightly fastened.

Please be sure that all screws are fastened, and that there are no loose screws.

- ⑤ Make sure each connectors are correctly inserted.

Please be sure that all connectors are inserted, and that there are no imperfect insertion.

- ⑥ Make sure the wiring cables are set to their original state.

Please replace the wiring and cables to the original state after repairs. In addition, be sure that there are no pinched wires, etc.

- ⑦ Make sure screws and soldering scraps do not remain inside the product.

Please check that neither solder debris nor screws remain inside the product.

- ⑧ There should be no semi-broken wires, scratches, melting, etc. on the coating of the power cord.

Damaged power cords may lead to fire accidents, so please be sure that there are no damages. If you find a damaged power cord, please exchange it with a suitable one.

- ⑨ There should be no spark traces or similar marks on the power plug.

When spark traces or similar marks are found on the power supply plug, please check the connection and advise on secure connections and suitable usage. Please exchange the power cord if necessary.

- ⑩ Safe environment should be secured during servicing.

When you perform repairs, please pay attention to static electricity, furniture, household articles, etc. in order to prevent injuries. Please pay attention to your surroundings and repair safely.

### 2. Adjustments



To keep the original performance of the products, optimum adjustments and confirmation of characteristics within specification. Adjustments should be performed in accordance with the procedures/instructions described in this manual.

### 3. Lubricants, Glues, and Replacement parts



Use grease and adhesives that are equal to the specified substance. Make sure the proper amount is applied.

### 4. Cleaning



For parts that require cleaning, such as optical pickups, tape deck heads, lenses and mirrors used in projection monitors, proper cleaning should be performed to restore their performances.

### 5. Shipping mode and Shipping screws



To protect products from damages or failures during transit, the shipping mode should be set or the shipping screws should be installed before shipment. Please be sure to follow this method especially if it is specified in this manual.

# CONTENTS

	SAFETY INFORMATION .....	2
	1. SPECIFICATIONS .....	5
A	2. EXPLODED VIEWS AND PARTS LIST .....	8
	2.1 PACKING .....	8
	2.2 EXTERIOR (DEH-1700/XN/UC) .....	10
	2.3 EXTERIOR (DEH-7/XN/UC) .....	12
	2.4 CD MECHANISM MODULE .....	14
	3. BLOCK DIAGRAM AND SCHEMATIC DIAGRAM .....	16
	3.1 BLOCK DIAGRAM .....	16
	3.2 OVERALL CONNECTION DIAGRAM(GUIDE PAGE).....	18
	3.3 KEYBOARD UNIT .....	24
	3.4 CD MECHANISM MODULE.....	26
	4. PCB CONNECTION DIAGRAM .....	30
	4.1 TUNER AMP UNIT .....	30
B	4.2 KEYBOARD UNIT .....	34
	4.3 CD CORE UNIT(S10) .....	36
	5. ELECTRICAL PARTS LIST .....	38
	6. ADJUSTMENT .....	41
	6.1 CD ADJUSTMENT .....	41
	6.2 CHECKING THE GRATING AFTER CHANGING THE PICKUP UNIT .....	43
	6.3 ERROR MODE .....	45
	6.4 SYSTEM MICROCOMPUTER TEST PROGRAM .....	46
	7. GENERAL INFORMATION .....	47
	7.1 DIAGNOSIS .....	47
	7.1.1 DISASSEMBLY .....	47
	7.1.2 CONNECTOR FUNCTION DESCRIPTION .....	50
C	7.2 PARTS.....	51
	7.2.1 IC .....	51
	7.2.2 DISPLAY .....	58
	7.3 OPERATIONAL FLOW CHART .....	59
	7.4 CLEANING.....	60
	8. OPERATIONS .....	61

D

E

F

# 1. SPECIFICATIONS

## ● DEH-1700/XN/UC

### General

Power source ..... 14.4 V DC (10.8 – 15.1 V allowable)  
Grounding system ..... Negative type  
Max. current consumption ..... 10.0 A

### Backup current ..... 5 mA or less

Dimensions (W × H × D):

#### DIN

Chassis ..... 178 × 50 × 157 mm  
(7 × 2 × 6-1/8 in.)  
Nose ..... 188 × 58 × 18 mm  
(7-3/8 × 2-1/4 × 3/4 in.)

#### D

Chassis ..... 178 × 50 × 162 mm  
(7 × 2 × 6-3/8 in.)  
Nose ..... 170 × 48 × 13 mm  
(6-3/4 × 1-7/8 × 1/2 in.)

Weight ..... 1.3 kg (2.9 lbs)

### Audio

Continuous power output is 20 W per channel minimum into 4 ohms, both channels driven 50 to 15,000 Hz with no more than 5% THD.

Maximum power output ..... 45 W × 4  
Load impedance ..... 4 Ω (4 – 8 Ω allowable)  
Preout max output level/output impedance ..... 2.2 V/1 kΩ

Bass/Treble:

#### Bass

Frequency ..... 100 Hz  
Gain ..... ±12dB

#### Treble

Frequency ..... 10 kHz  
Gain ..... ±12dB

Loudness contour

Low ..... +7 dB (100 Hz), +4 dB (10 kHz)  
High ..... +10 dB (100 Hz), +6.5 dB (10 kHz)  
(volume: –30 dB)

### CD player

System ..... Compact disc audio system  
Usable discs ..... Compact disc  
Signal format:  
Sampling frequency ..... 44.1 kHz  
Number of quantization bits ..... 16; linear  
Frequency characteristics ... 5 – 20,000 Hz (±1 dB)

Signal-to-noise ratio ..... 94 dB (1 kHz) (IHF-A network)  
Dynamic range ..... 92 dB (1 kHz)  
Number of channels ..... 2 (stereo)

### FM tuner

Frequency range ..... 87.9 – 107.9 MHz  
Usable sensitivity ..... 8 dBf (0.7 μV/75 Ω, mono, S/N: 30 dB)  
50 dB quieting sensitivity ..... 10 dBf (0.9 μV/75 Ω, mono)  
Signal-to-noise ratio ..... 75 dB (IHF-A network)  
Distortion ..... 0.3 % (at 65 dBf, 1 kHz, stereo)  
0.1 % (at 65 dBf, 1 kHz, mono)  
Frequency response ..... 30 – 15,000 Hz (±3 dB)  
Stereo separation ..... 45 dB (at 65 dBf, 1 kHz)  
Selectivity ..... 80 dB (±200 kHz)  
Three-signal intermodulation (desired signal level) ..... 30 dBf (two undesired signal level: 100 dBf)

### AM tuner

Frequency range ..... 530 – 1,710 kHz (10 kHz)  
Usable sensitivity ..... 18 μV (S/N: 20 dB)  
Signal-to-noise ratio ..... 65 dB (IHF-A network)



### Note

Specifications and the design are subject to possible modifications without notice due to improvements. □

## ● DEH-7/XN/UC

### General

Power source ..... 14.4 V DC (10.8 – 15.1 V allowable)  
 Grounding system ..... Negative type  
 Max. current consumption ..... 10.0 A

### Backup current ..... 5 mA or less

Dimensions (W × H × D):

#### DIN

Chassis ..... 178 × 50 × 157 mm  
 (7 × 2 × 6-1/8 in.)  
 Nose ..... 188 × 58 × 18 mm  
 (7-3/8 × 2-1/4 × 3/4 in.)

#### D

Chassis ..... 178 × 50 × 162 mm  
 (7 × 2 × 6-3/8 in.)  
 Nose ..... 170 × 46 × 13 mm  
 (6-3/4 × 1-3/4 × 1/2 in.)

Weight ..... 1.3 kg (2.9 lbs)

### Audio

Continuous power output is 17 W per channel minimum into 4 ohms, both channels driven 50 to 15,000 Hz with no more than 5% THD.

Maximum power output ..... 40 W × 4

Load impedance ..... 4 Ω (4 – 8 Ω allowable)

Preout max output level/output impedance ..... 2.2 V/1 kΩ

Bass/Treble:

#### Bass

Frequency ..... 100 Hz  
 Gain ..... ±12dB

#### Treble

Frequency ..... 10 kHz  
 Gain ..... ±12dB

Loudness contour

Low ..... +7 dB (100 Hz), +4 dB (10 kHz)

High ..... +10 dB (100 Hz), +6.5 dB (10 kHz)  
 (volume: –30 dB)

### CD player

System ..... Compact disc audio system

Usable discs ..... Compact disc

Signal format:

Sampling frequency ..... 44.1 kHz

Number of quantization bits

..... 16; linear

Frequency characteristics ... 5 – 20,000 Hz (±1 dB)

Signal-to-noise ratio ..... 94 dB (1 kHz) (IHF-A network)

Dynamic range ..... 92 dB (1 kHz)

Number of channels ..... 2 (stereo)

### FM tuner

Frequency range ..... 87.9 – 107.9 MHz

Usable sensitivity ..... 8 dBf (0.7 μV/75 Ω, mono, S/N: 30 dB)

50 dB quieting sensitivity ..... 10 dBf (0.9 μV/75 Ω, mono)

Signal-to-noise ratio ..... 75 dB (IHF-A network)

Distortion ..... 0.3 % (at 65 dBf, 1 kHz, stereo)  
 0.1 % (at 65 dBf, 1 kHz, mono)

Frequency response ..... 30 – 15,000 Hz (±3 dB)

Stereo separation ..... 45 dB (at 65 dBf, 1 kHz)

Selectivity ..... 80 dB (±200 kHz)

Three-signal intermodulation (desired signal level)

..... 30 dBf (two undesired signal level: 100 dBf)

### AM tuner

Frequency range ..... 530 – 1,710 kHz (10 kHz)

Usable sensitivity ..... 18 μV (S/N: 20 dB)

Signal-to-noise ratio ..... 65 dB (IHF-A network)



### Note

Specifications and the design are subject to possible modifications without notice due to improvements. □

■

5

■

6

■

7

■

8

■

A

■

B

■

C

■

D

■

E

■

F

■

5

■

6

DEH-1700/XN/UC

■

7

■



8

7

■

## 2. EXPLODED VIEWS AND PARTS LIST

NOTES : • Parts marked by "\*" are generally unavailable because they are not in our Master Spare Parts List.

- The  mark found on some component parts indicates the importance of the safety factor of the part. Therefore, when replacing, be sure to use parts of identical designation.
- Screw adjacent to  mark on the product are used for disassembly.
- For the applying amount of lubricants or glue, follow the instructions in this manual. (In the case of no amount instructions, apply as you think it appropriate.)

### 2.1 PACKING

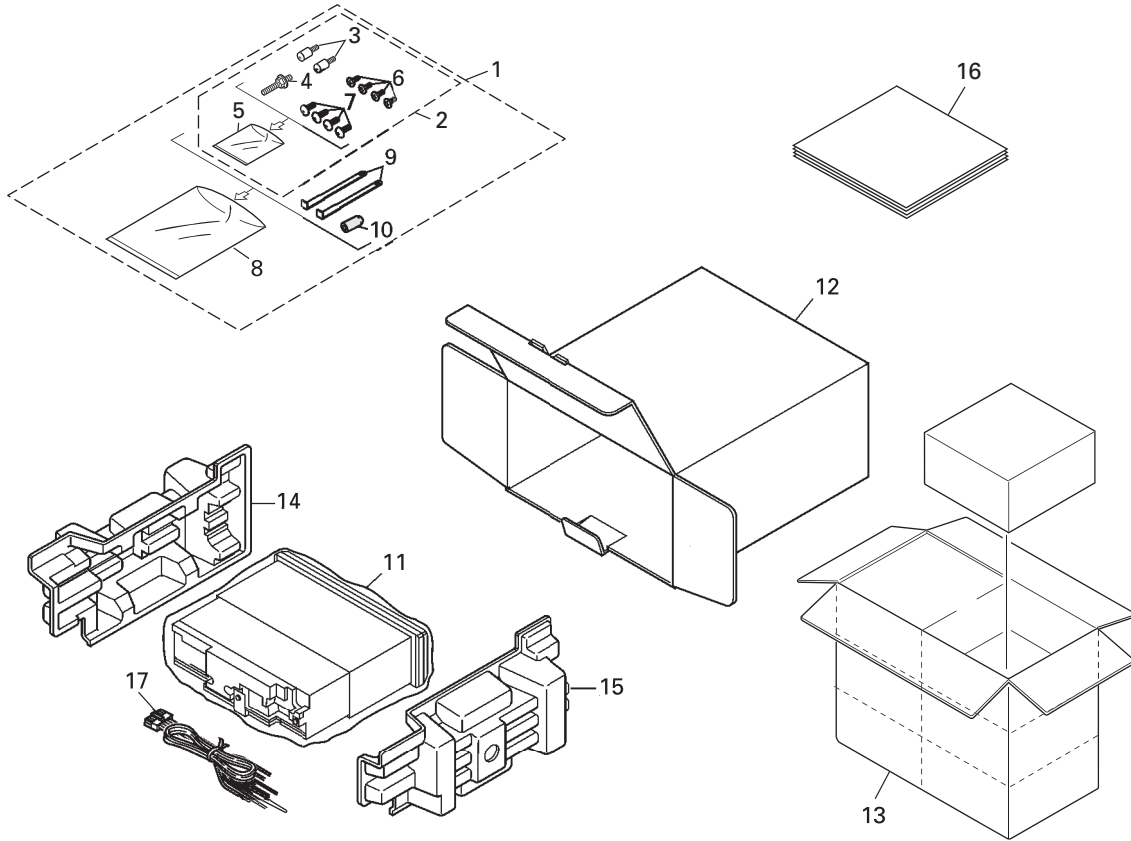



**PACKING SECTION PARTS LIST**

<u>Mark No.</u>	<u>Description</u>	<u>Part No.</u>	<u>Mark No.</u>	<u>Description</u>	<u>Part No.</u>
1	Accessory Assy(DEH-1700)	CEA4610		Carton(DEH-7)	CHG5350
	Accessory Assy(DEH-7)	CEA4855			
2	Screw Assy(DEH-1700)	CEA4611	13	Contain Box(DEH-1700)	CHL5349
	Screw Assy(DEH-7)	CEA3849		Contain Box(DEH-7)	CHL5350
3	Screw(M2x4)(DEH-1700)	CBA1488	14	Protector	CHP2664
			15	Protector	CHP2868
4	Screw	CBA1650	16-1	Owner's Manual(DEH-1700)	CRD3906
*	Polyethylene Bag	CEG-127	16-2	Owner's Manual(DEH-7)	CRD3908
6	Screw	CRZ50P090FTC	16-3	Installation Manual(DEH-1700)	CRD3907
7	Screw	TRZ50P080FTC	16-4	Installation Manual(DEH-7)	CRD3909
*	Polyethylene Bag	CEG-158	*	16-5 Caution Card	CRP1294
9	Handle	CNC5395	16-6	Caution Card	CRP1310
10	Bush	CNV3930			
11	Polyethylene Bag	CEG1173	*	16-7 Card	ARY1048
12	Carton(DEH-1700)	CHG5420	17	Cord Assy	XDE7008

**Owner's Manual,Installation Manual**

<b>Part No.</b>	<b>Language</b>
CRD3906	English, French, Spanish
CRD3907	English, French, Spanish
CRD3908	English, French, Spanish
CRD3909	English, French, Spanish

## 2.2 EXTERIOR (DEH-1700/XN/UC)

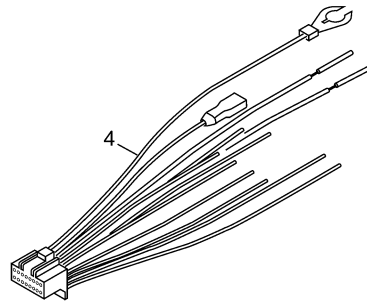
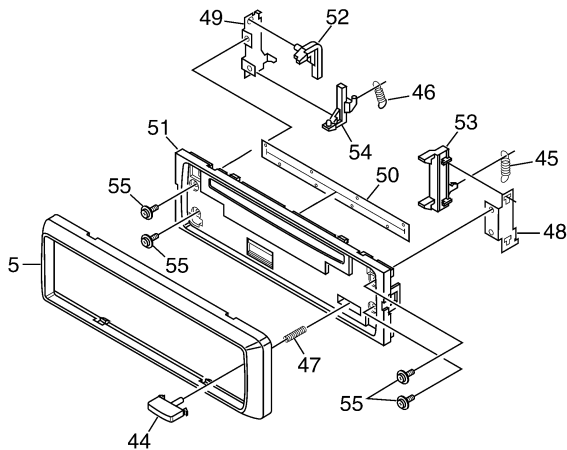
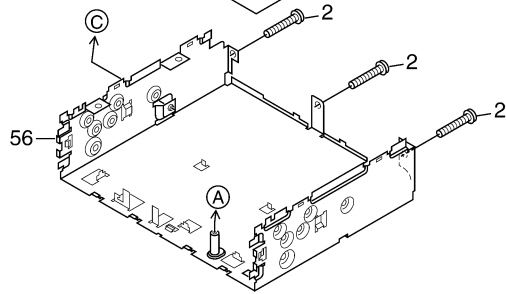
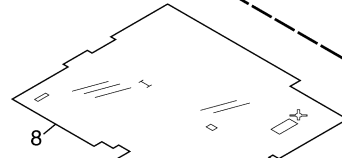
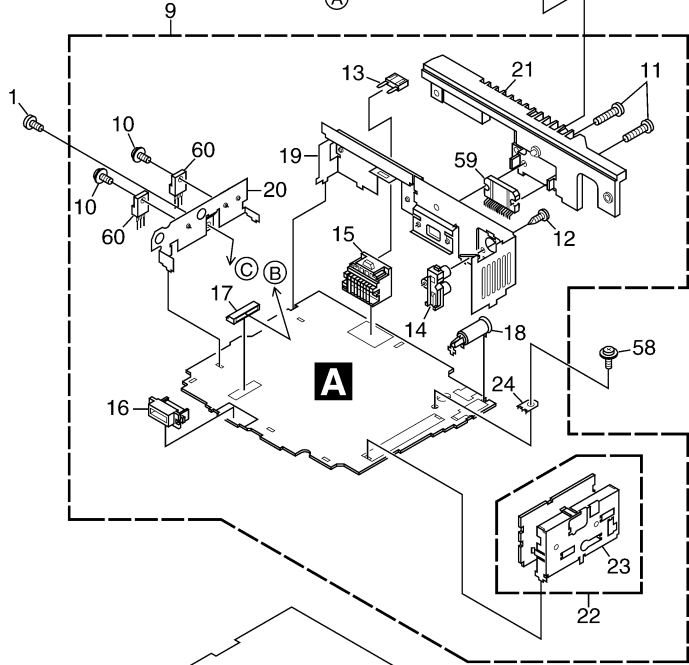
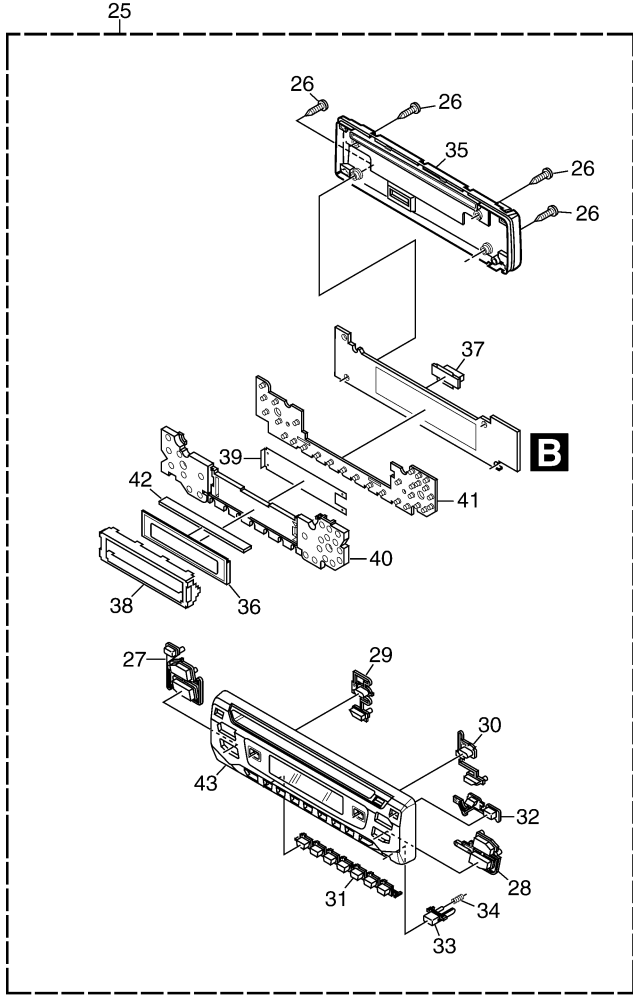
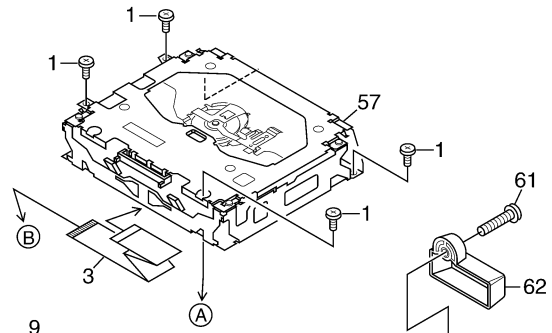
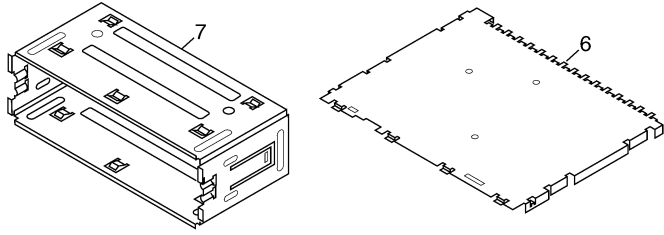

## EXTERIOR (DEH-1700/XN/UC) SECTION PARTS LIST

<u>Mark No.</u>	<u>Description</u>	<u>Part No.</u>	<u>Mark No.</u>	<u>Description</u>	<u>Part No.</u>
1	Screw	BSZ26P060FTC	50	Cover	CNM6276
2	Screw	BSZ26P100FTC			
3	Cable	CDE7702	51	Panel	CNS8044
4	Cord Assy	XDE7008	52	Arm	CNV4692
5	Panel	CNS8046	53	Arm	CNV4728
			54	Arm	CNV5576
6	Case	CNB2793	55	Screw	IMS20P030FZK
7	Holder	CNC8659			
8	Insulator	CNM9145	56	Chassis Unit	CXC3600
9	Tuner Amp Unit	CWM9604	57	CD Mechanism Module(S10)	CXK5605
10	Screw	ASZ26P060FTC	58	Screw	ISS26P055FTC
			59	IC(IC302)	TDA7386
11	Screw	BMZ26P160FTC	60	Transistor(Q921,991)	2SD2396
12	Screw	BPZ26P080FTC			
⚠ 13	Fuse(10A)	CEK1208	61	Screw	BMZ40P140FTC
14	Pin Jack(CN352)	CKB1059	62	Holder	CNV7619
15	Plug(CN901)	CKM1376			
16	Connector(CN831)	CKS3581			
17	Connector(CN651)	CKS3835			
18	Antenna Jack(CN401)	CKX1056			
19	Holder	CND2413			
20	Holder	CND2414			
21	Heat Sink	CNR1762			
22	FM/AM Tuner Unit	CWE1912			
23	Holder	CND1054			
24	Terminal(CN402)	VNF1084			
25	Detach Grille Assy	CXC3540			
26	Screw	BPZ20P100FZK			
27	Button(VOLUME)	CAC8924			
28	Button(SELECT)	CAC8925			
29	Button(BTB,SRC)	CAC8927			
30	Button(LOUD,BAND)	CAC8928			
31	Button(1-6)	CAC8929			
32	Button(CD EJECT,AUDIO)	CAC8930			
33	Button(DETACH)	CAC8931			
34	Spring	CBH2210			
35	Cover	CNS8042			
36	LCD	CAW1848			
37	Connector(CN1801)	CKS3580			
38	Holder	CND2412			
39	Sheet	CNM9144			
40	Lighting Conductor	CNV8190			
41	Rubber	CNV8191			
42	Connector	CNV8192			
43	Grille Unit	CXC3593			
44	Button	CAC4836			
45	Spring	CBH1835			
46	Spring	CBH2208			
47	Spring	CBH2367			
48	Bracket	CNC6791			
49	Holder	CNC8042			

# 2.3 EXTERIOR (DEH-7/XN/UC)

A

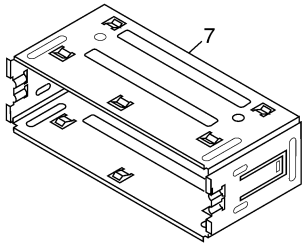

B

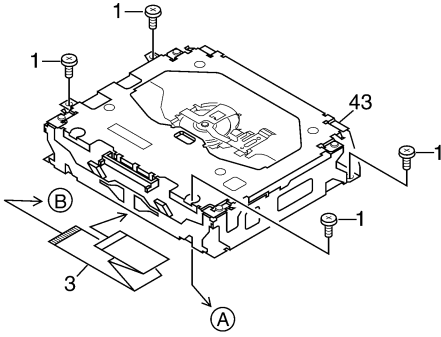

C

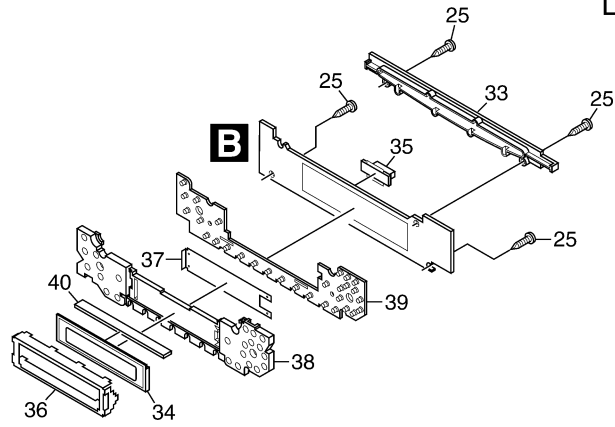

D

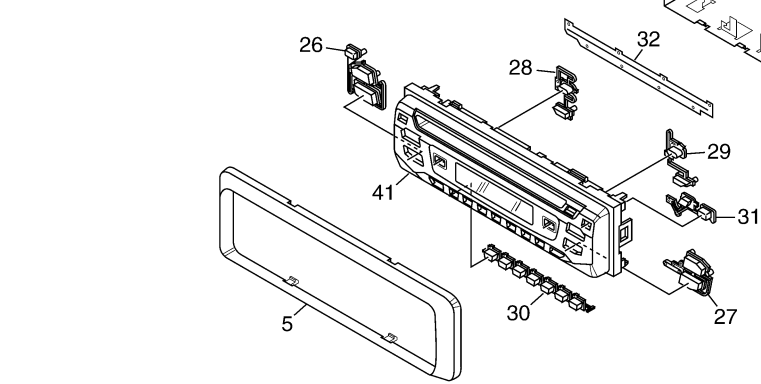

E

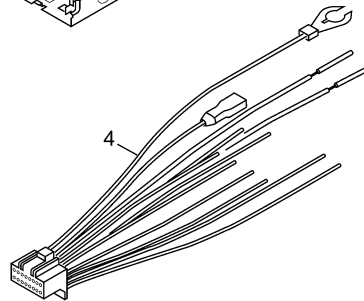

F

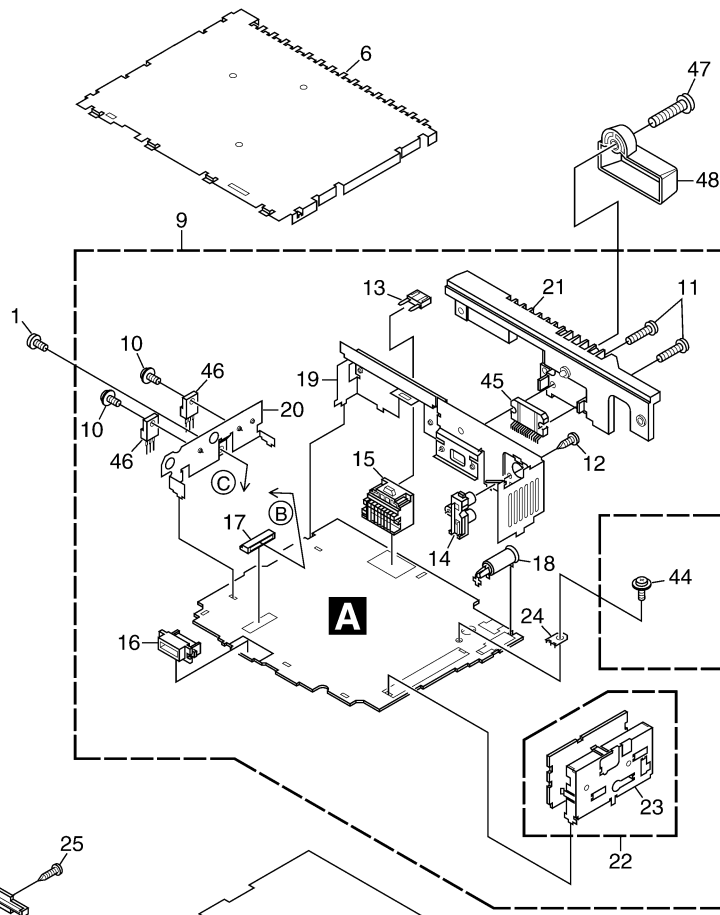

## EXTERIOR (DEH-7/XN/UC) SECTION PARTS LIST

<u>Mark No.</u>	<u>Description</u>	<u>Part No.</u>	
1	Screw	BSZ26P060FTC	
2	Screw	BSZ26P100FTC	A
3	Cable	CDE7702	
4	Cord Assy	XDE7008	
5	Panel	CNS8048	
6	Case	CNB2793	
7	Holder	CNC8659	
8	Insulator	CNM9145	
9	Tuner Amp Unit	CWM9607	
10	Screw	ASZ26P060FTC	
11	Screw	BMZ26P160FTC	B
12	Screw	BPZ26P080FTC	
⚠ 13	Fuse(10A)	CEK1208	
14	Pin Jack(CN352)	CKB1059	
15	Plug(CN901)	CKM1376	
16	Connector(CN831)	CKS3581	
17	Connector(CN651)	CKS3835	
18	Antenna Jack(CN401)	CKX1056	
19	Holder	CND2413	
20	Holder	CND2414	C
21	Heat Sink	CNR1762	
22	FM/AM Tuner Unit	CWE1912	
23	Holder	CND1054	
24	Terminal(CN402)	VNF1084	
25	Screw	BPZ20P080FTC	
26	Button(VOLUME)	CAC8924	
27	Button(SELECT)	CAC8925	
28	Button(BTB, SRC)	CAC8927	
29	Button(LOUD, BAND)	CAC8928	
30	Button(1-6)	CAC8929	D
31	Button(CD EJECT, AUDIO)	CAC8930	
32	Cover	CNM9159	
33	Holder	CNV8212	
34	LCD	CAW1848	
35	Connector(CN1801)	CKS3580	
36	Holder	CND2412	
37	Sheet	CNM9144	
38	Lighting Conductor	CNV8190	E
39	Rubber	CNV8191	
40	Connector	CNV8192	
41	Grille Unit	CXC3595	
42	Chassis Unit	CXC3600	
43	CD Mechanism Module(S10)	CXK5605	
44	Screw	ISS26P055FTC	
45	IC(IC302)	TDA7384	
46	Transistor(Q921, 991)	2SD2396	
47	Screw	BMZ40P140FTC	F
48	Holder	CNV7619	

# 2.4 CD MECHANISM MODULE

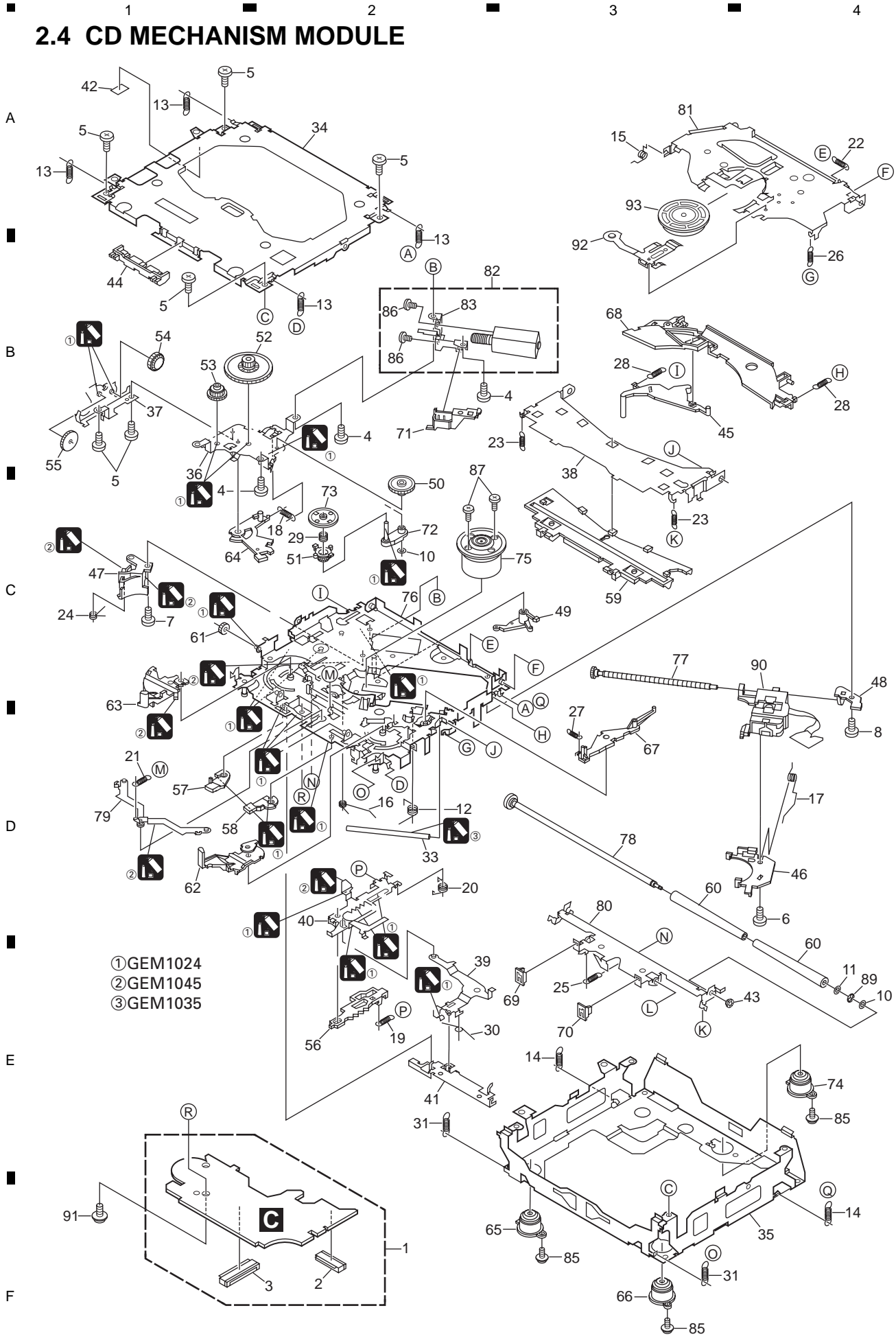

- ① GEM1024
- ② GEM1045
- ③ GEM1035

## CD MECHANISM MODULE SECTION PARTS LIST

<u>Mark No.</u>	<u>Description</u>	<u>Part No.</u>	<u>Mark No.</u>	<u>Description</u>	<u>Part No.</u>
1	CD Core Unit(S10)	CWX3110	50	Gear	CNV8379
2	Connector(CN101)	CKS4182			
3	Connector(CN701)	CKS4188	51	Gear	CNV8380
4	Screw	BMZ20P035FTC	52	Gear	CNV8381
5	Screw	BSZ20P040FTC	53	Gear	CNV8382
			54	Gear	CNV8383
			55	Gear	CNV8384
6	Screw(M2x4)	CBA1362			
7	Screw(M2x3)	CBA1824			
8	Screw(M2x3)	CBA1825	56	Rack	CNV8385
9	.....		57	Arm	CNV8386
10	Washer	CBF1038	58	Arm	CNV8387
			59	Guide	CNV8388
			60	Roller	CNV7218
11	Washer	CBF1060			
12	Spring	CBH2390			
13	Spring	CBH2606	61	Gear	CNV8389
14	Spring	CBH2607	62	Arm	CNV8391
15	Spring	CBH2608	63	Arm	CNV8390
			64	Arm	CNV8392
16	Spring	CBH2609	65	Damper	CNV7313
17	Spring	CBH2610			
18	Spring	CBH2735	66	Damper	CNV7314
19	Spring	CBH2612	67	Arm	CNV8394
20	Spring	CBH2613	68	Arm	CNV8395
			69	Guide	CNV8396
21	Spring	CBH2614	70	Guide	CNV8397
22	Spring	CBH2615			
23	Spring	CBH2616	71	Holder	CNV8398
24	Spring	CBH2617	72	Arm	CNV8402
25	Spring	CBH2620	73	Gear	CNV8400
			74	Damper	CNV7618
26	Spring	CBH2621	75	Motor Unit(M1)	CXC4440
27	Spring	CBH2641			
28	Spring	CBH2642	76	Chassis Unit	CXC2318
29	Spring	CBH2643	77	Screw Unit	CXB8729
30	Spring	CBH2659	78	Gear Unit	CXC2397
			79	Arm Unit	CXC2316
31	Spring	CBH2688	80	Arm	CND1896
32	.....				
33	Shaft	CLA4441	81	Arm	CND1894
34	Frame	CNC9962	82	Motor Unit(M2)	CXB8933
35	Frame	CNC9963	83	Bracket	CNC9985
			84	.....	
36	Bracket	CND2712	85	Screw(M2x5)	EBA1028
37	Bracket	CND1895			
38	Arm	CNC9968	86	Screw	JFZ20P020FTC
39	Arm	CND1909	87	Screw	JGZ17P022FTC
40	Lever	CND2032	88	.....	
			89	Washer	YE20FTC
41	Lever	CNC9984	90	Pickup Unit(P10)(Service)	CXX1641
42	Sheet	CNM8134			
43	Collar	CNV7798	91	Screw	IMS26P030FTC
44	Guide	CNV7799	92	Spring	CBL1635
45	Arm	CNV8403	93	Clamper	CNV8372
46	Rack	CNV8374			
47	Holder	CNV8376			
48	Holder	CNV8377			
49	Arm	CNV8378			

# 3. BLOCK DIAGRAM AND SCHEMATIC DIAGRAM

## 3.1 BLOCK DIAGRAM

### A TUNER AMP UNIT

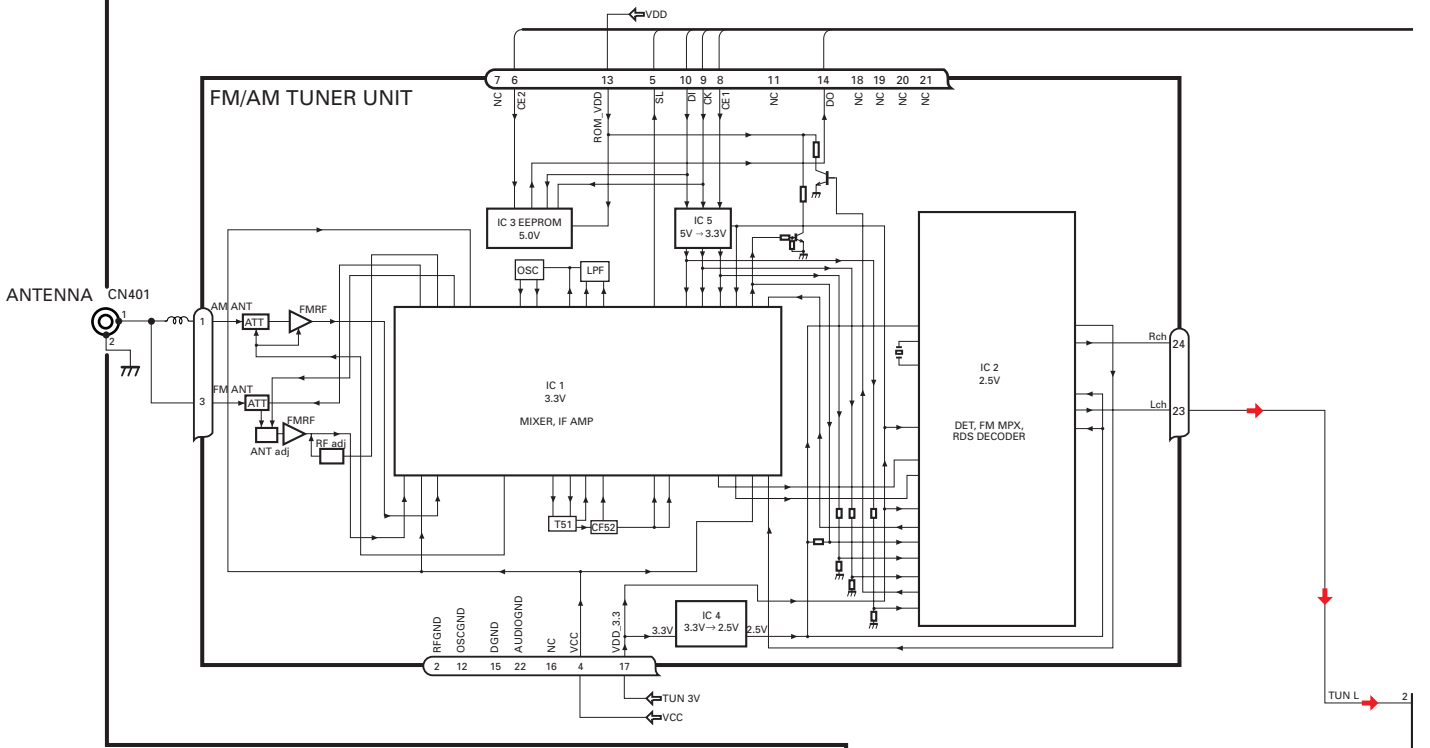

### D PICKUP UNIT (P10)(SERVICE)

### C CD CORE UNIT(S10)

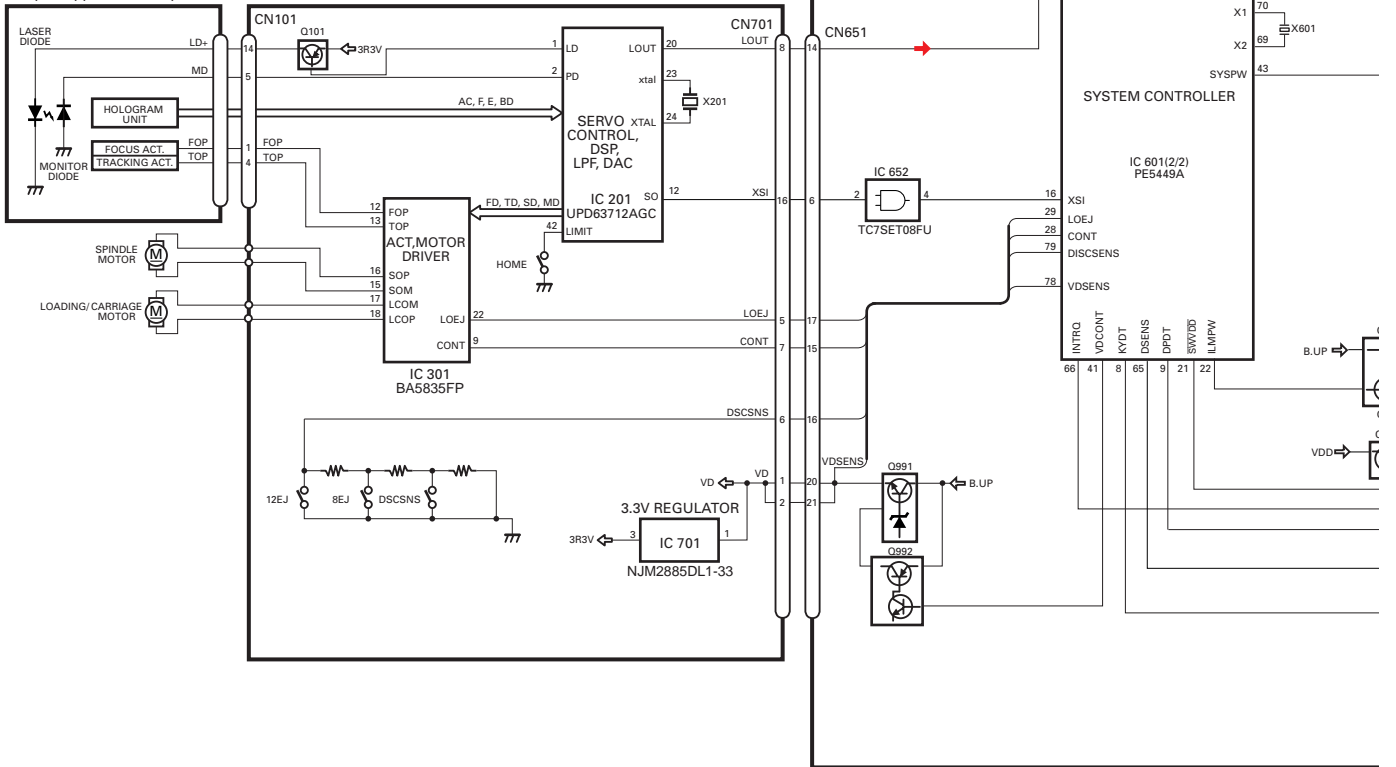



A  
B  
C  
D  
E  
F

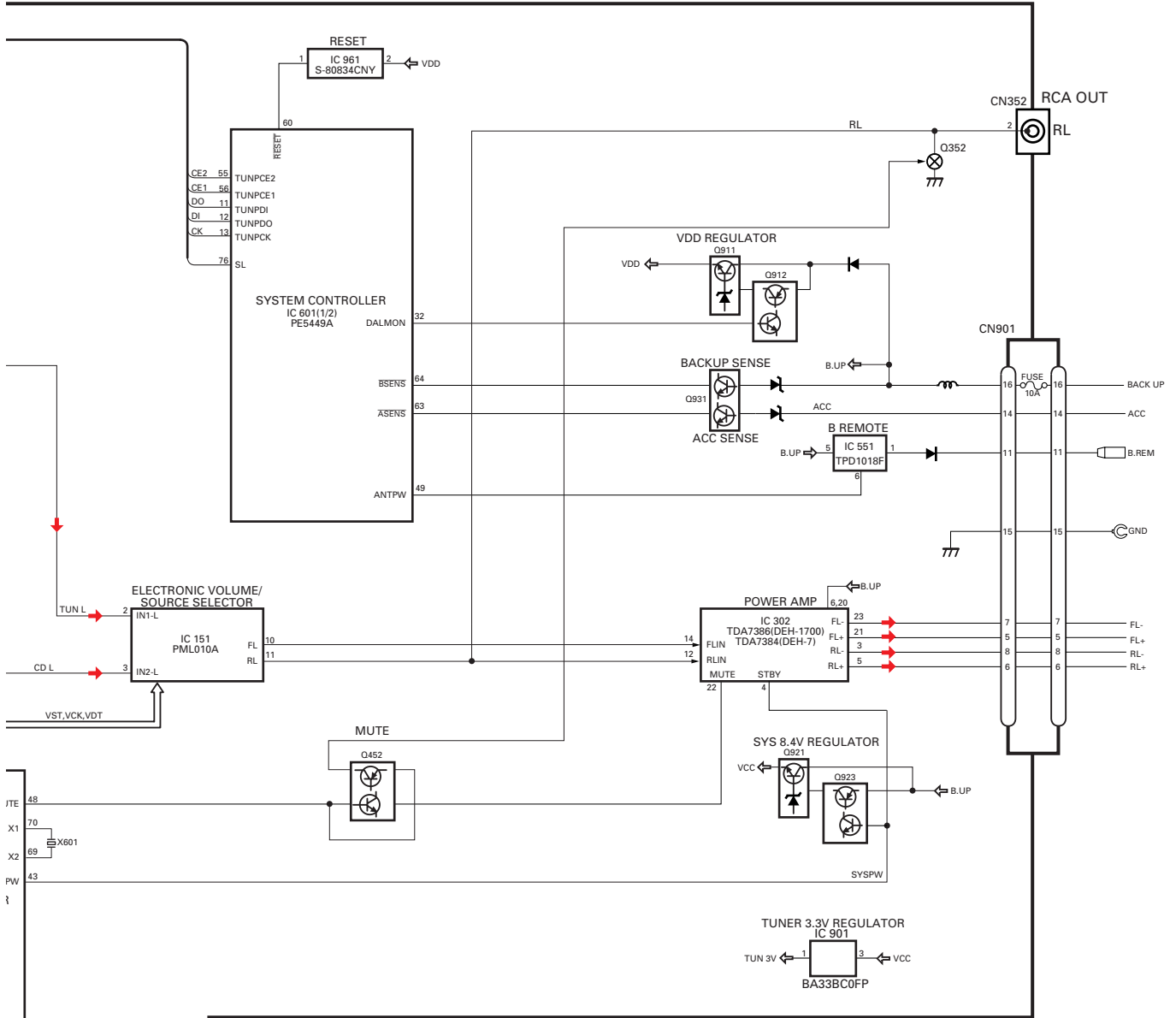

**B** KEYBOARD UNIT

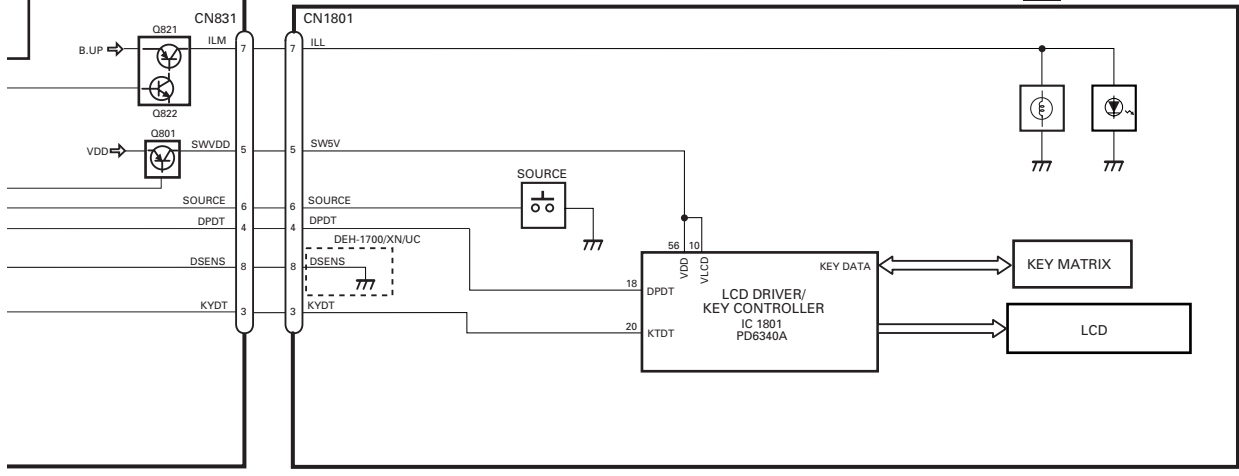

# 3.2 OVERALL CONNECTION DIAGRAM(GUIDE PAGE)

Note: When ordering service parts, be sure to refer to "EXPLODED VIEWS AND PARTS LIST" or "ELECTRICAL PARTS LIST".

A  
B  
C  
D  
E  
F

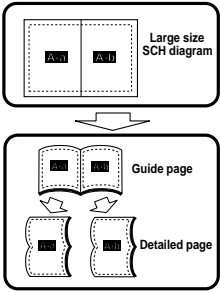

A-a

STB.TVA	
23	NC
22	NC
21	V51
20	SP1
19	CLCONT
18	INTO
17	COLDEJ
16	DSCSAS
15	CONT
14	CLK
13	AGND
12	CDR
11	CLAMP
10	XRS1
9	XSTB
8	XSR
7	XSKC
6	XSI
5	XSO
4	XSD
3	XND
2	XPD
1	XPD

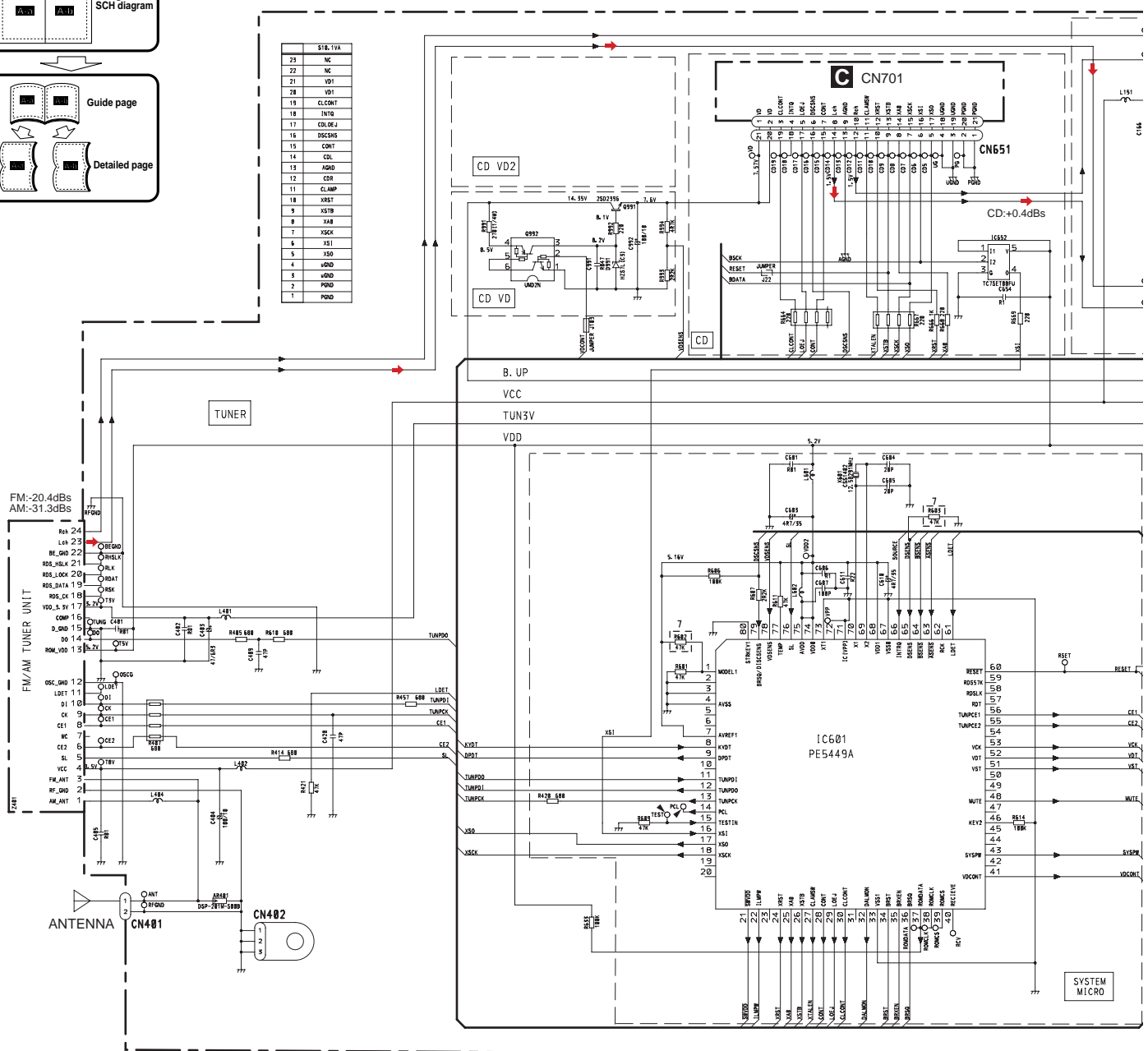

**NOTE :**  
 □ Symbol indicates a resistor.  
 No differentiation is made between chip resistors and discrete resistors.  
 ▭ Symbol indicates a capacitor.  
 No differentiation is made between chip capacitors and discrete capacitors.

Decimal points for resistor and capacitor fixed values are expressed as :  
 2.2 → 2R2  
 0.022 → R022

The Δ mark found on some component parts indicates the importance of the safety factor of the part. Therefore, when replacing, be sure to use parts of identical designation.

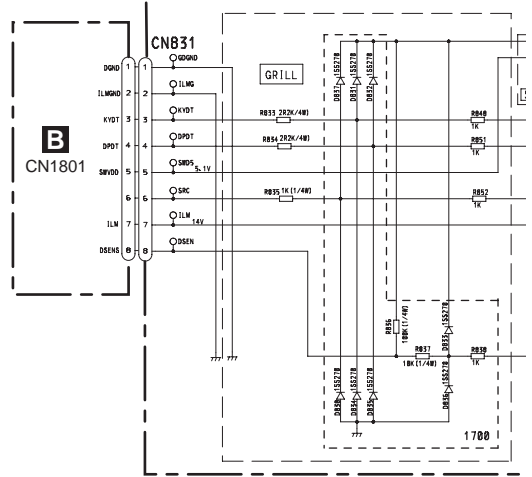

A

# A-b

## A TUNER AMP UNIT

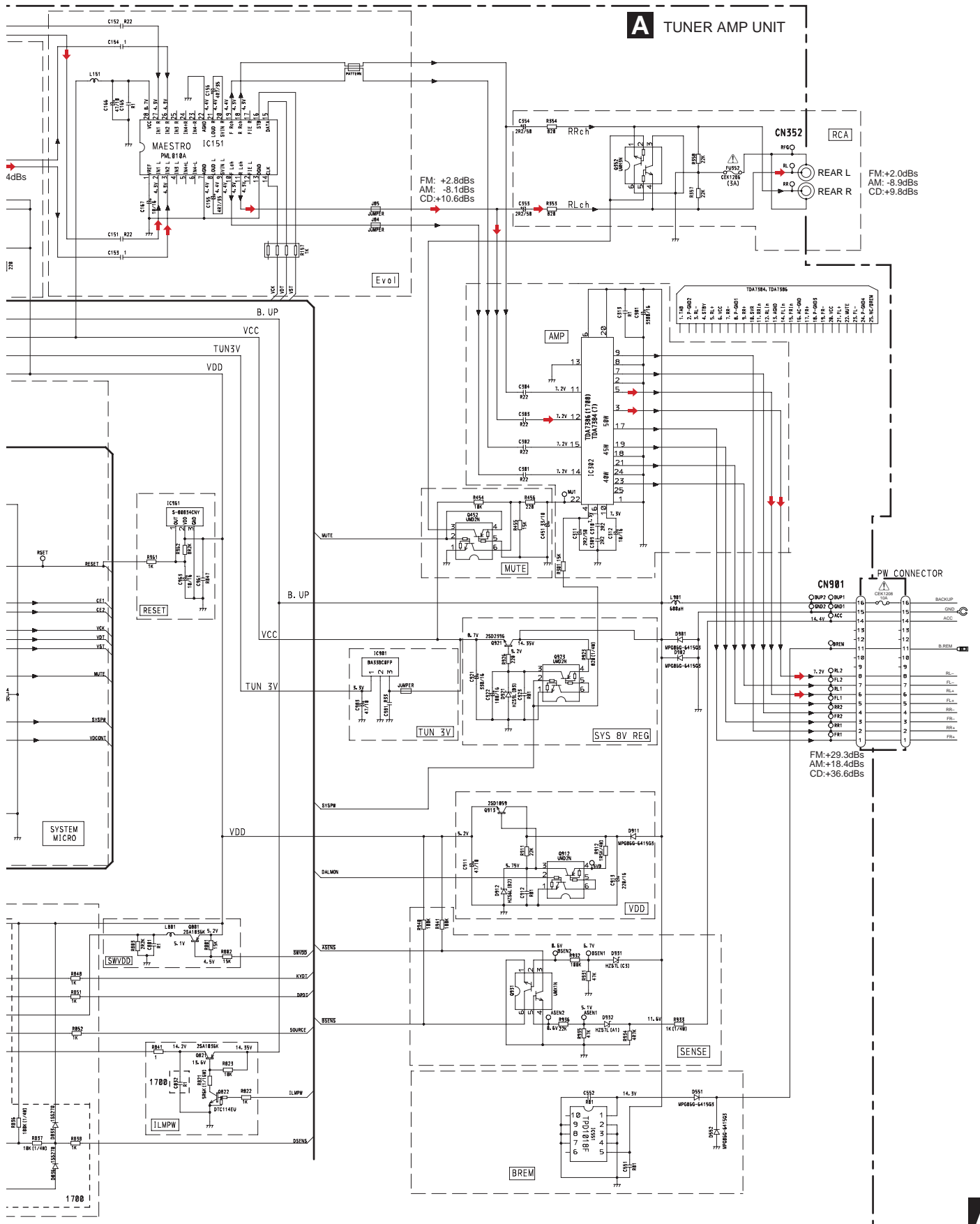

A  
B  
C  
D  
E  
F



A  
B  
C  
D  
E  
F

A-b

A-a

A-a

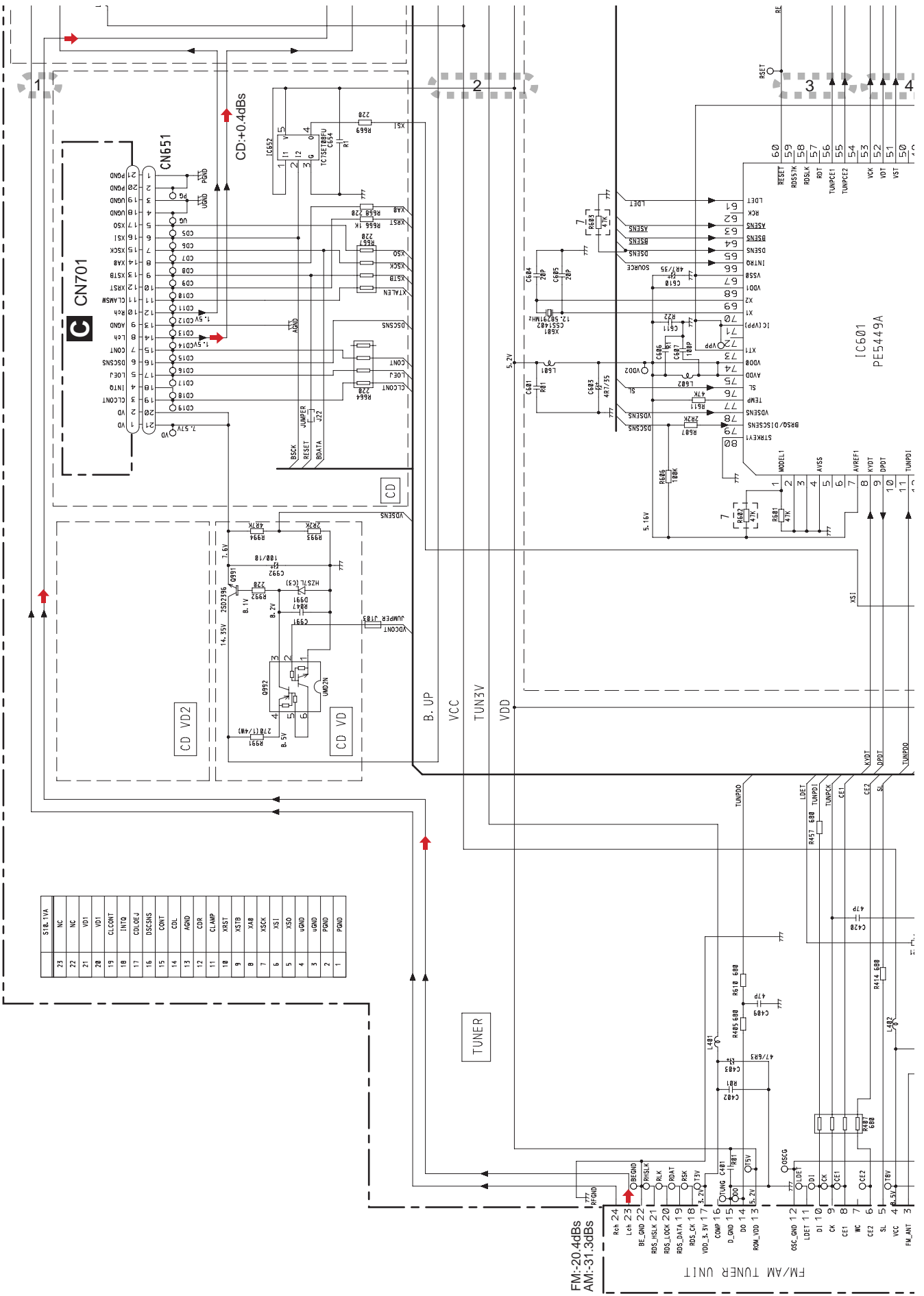

Pin	Function
23	STR.1VA
22	NC
21	NC
20	VD1
19	VD1
18	CLCONT
17	INTQ
16	COLDEJ
15	DISCSNS
14	COL
13	AGND
12	CDR
11	CLAMP
10	XRST
9	XRSTB
8	XAB
7	XACK
6	XSI
5	XSD
4	uGND
3	uGND
2	PGND
1	PGND

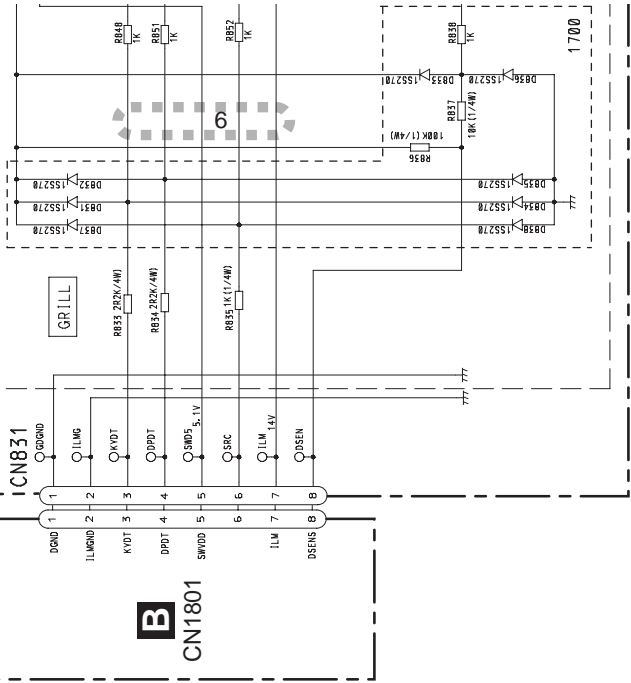
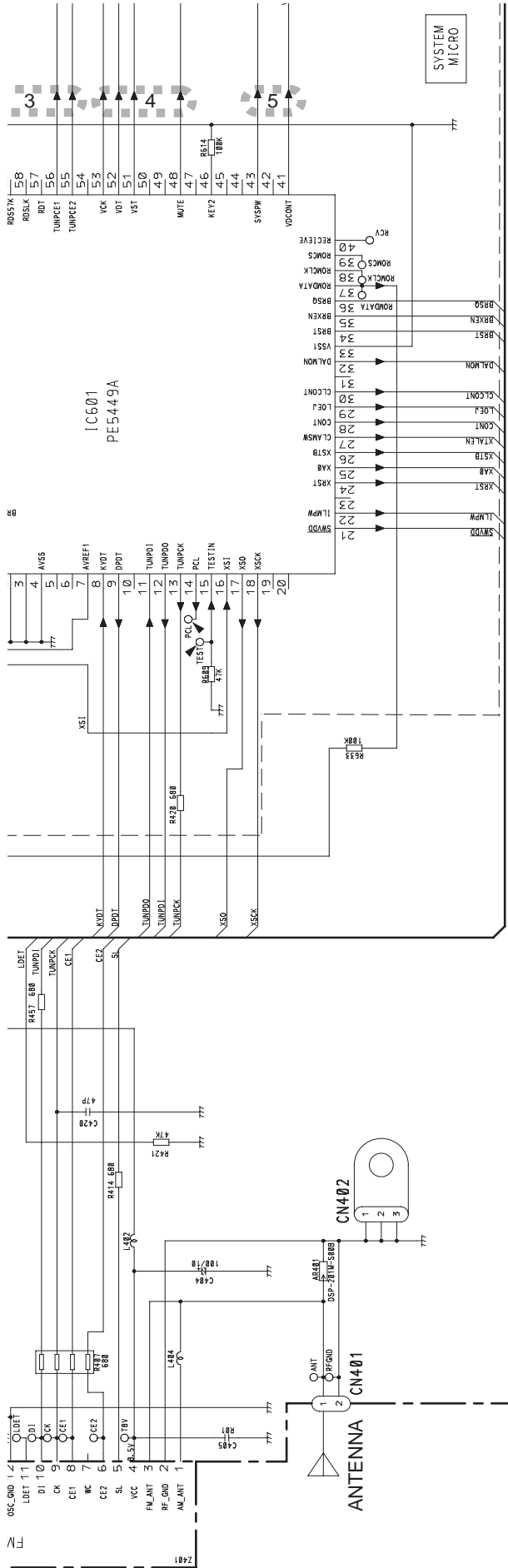

NOTE :

- Symbol indicates a resistor.
- Symbol indicates a capacitor.

No differentiation is made between chip resistors and discrete resistors.

No differentiation is made between chip capacitors and discrete capacitors.

The  $\Delta$  mark found on some component parts indicates the importance of the safety factor of the part. Therefore, when replacing, be sure to use parts of identical designation.

A

B

C

D

E

F

# A TUNER AMP UNIT

A-a A-b

A-b

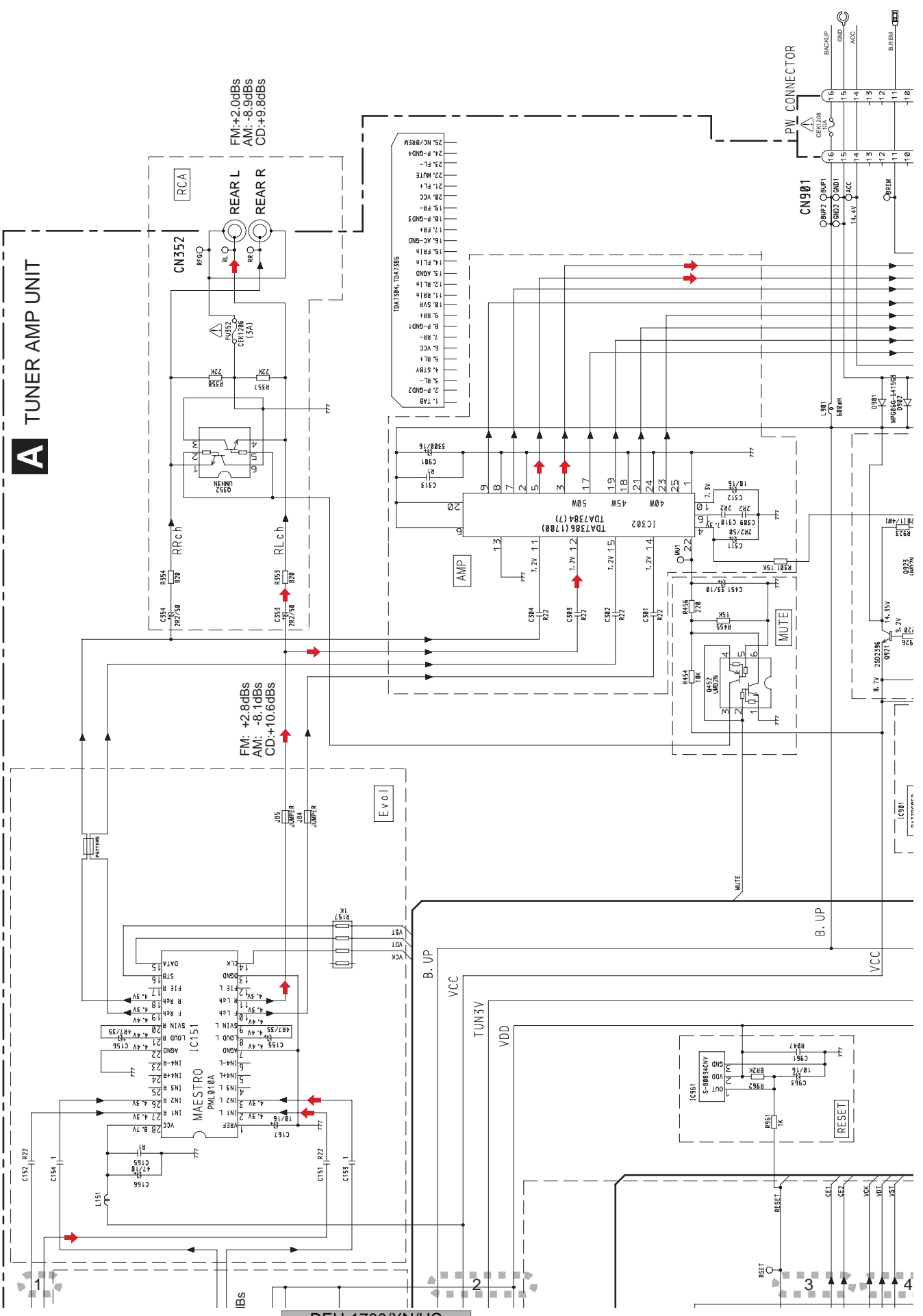

DEH-1700/XN/UC

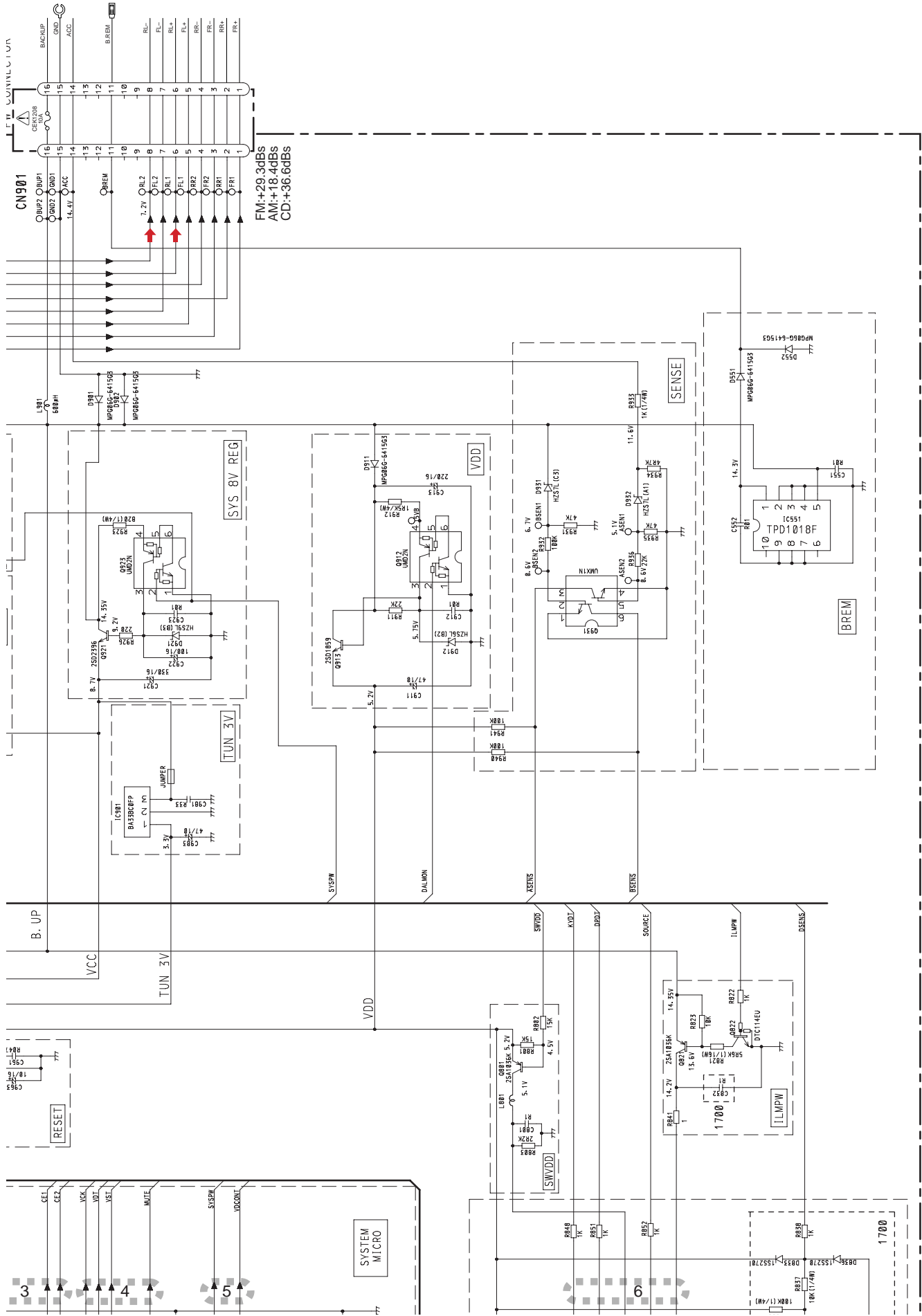

FM:+29.3dBs  
 AM:+18.4dBs  
 CD:+36.6dBs

A  
 B  
 C  
 D  
 E  
 F

A-a A-b

A-b

# 3.3 KEYBOARD UNIT

A  
B  
C  
D  
E  
F

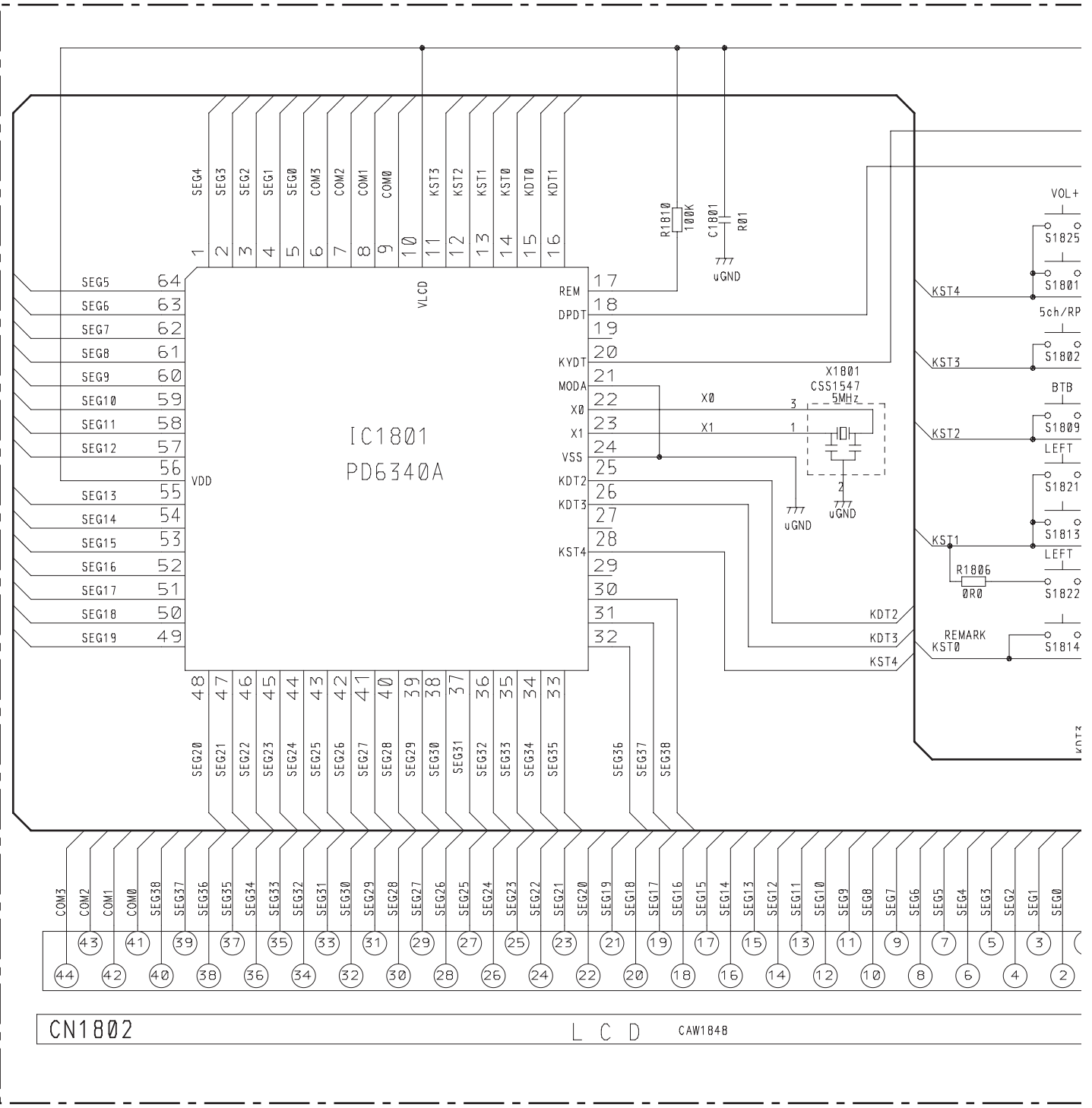

**B**



# B KEYBOARD UNIT

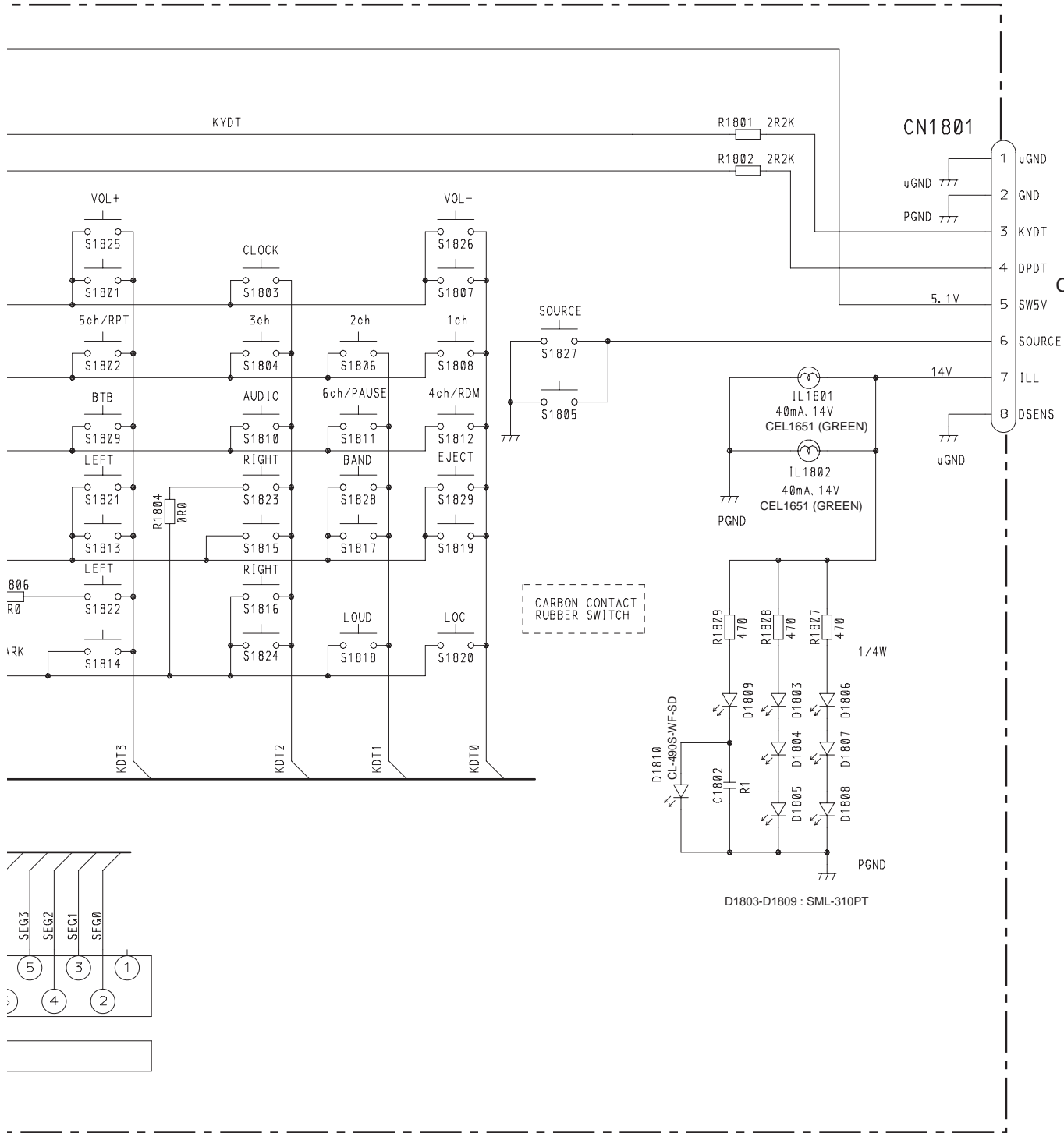

**A** CN831

**B**

# 3.4 CD MECHANISM MODULE

## PICKUP UNIT(P10)(SERVICE)

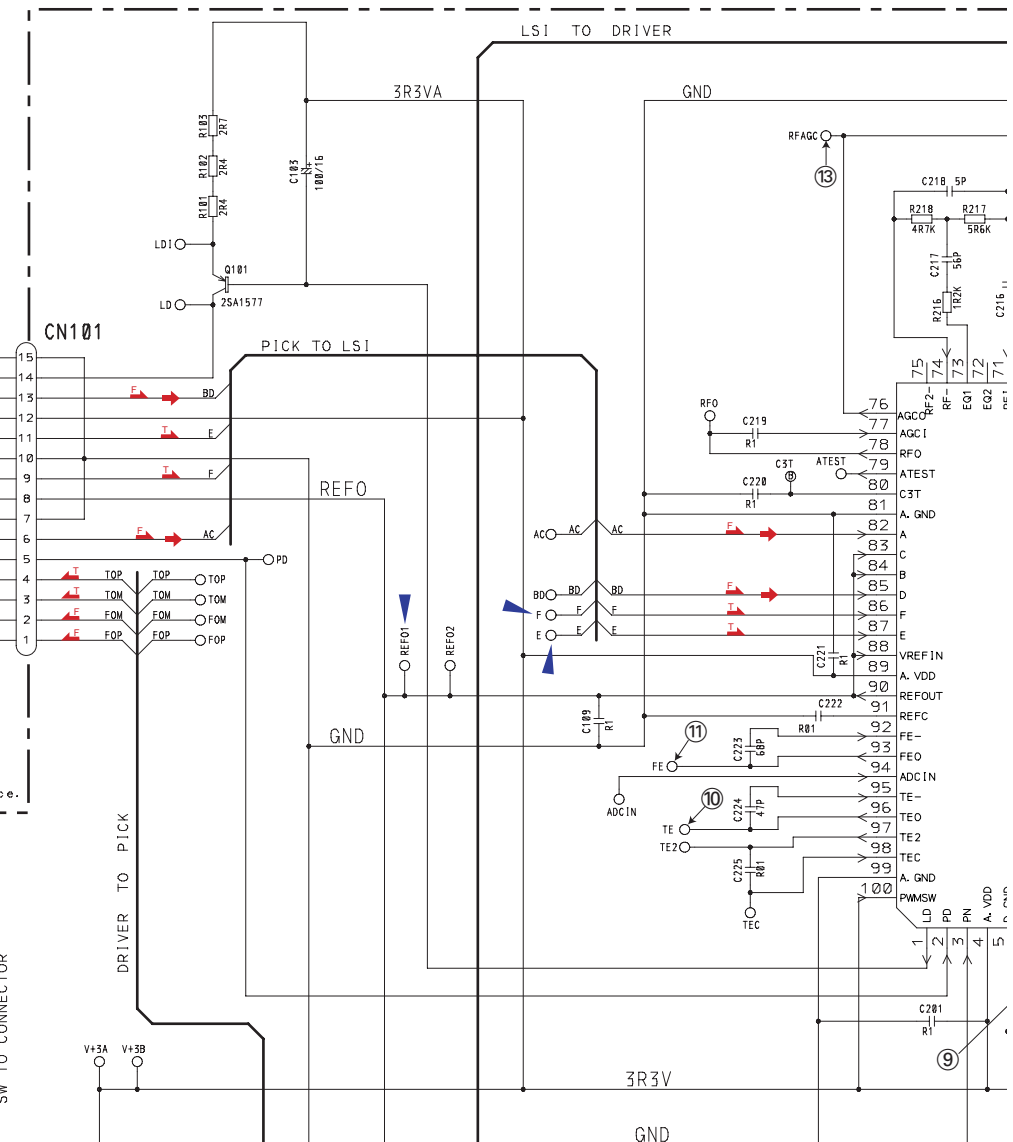
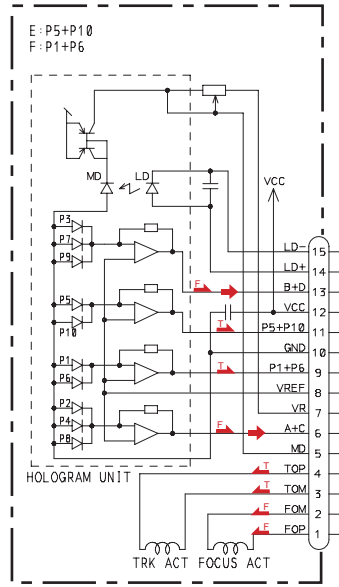

F. ACT: Applying positive voltage to FOP, the lens moves DiSc side.  
 T. ACT: Applying positive voltage to TOP, the lens moves outer circumference.

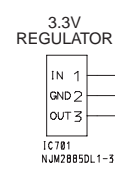
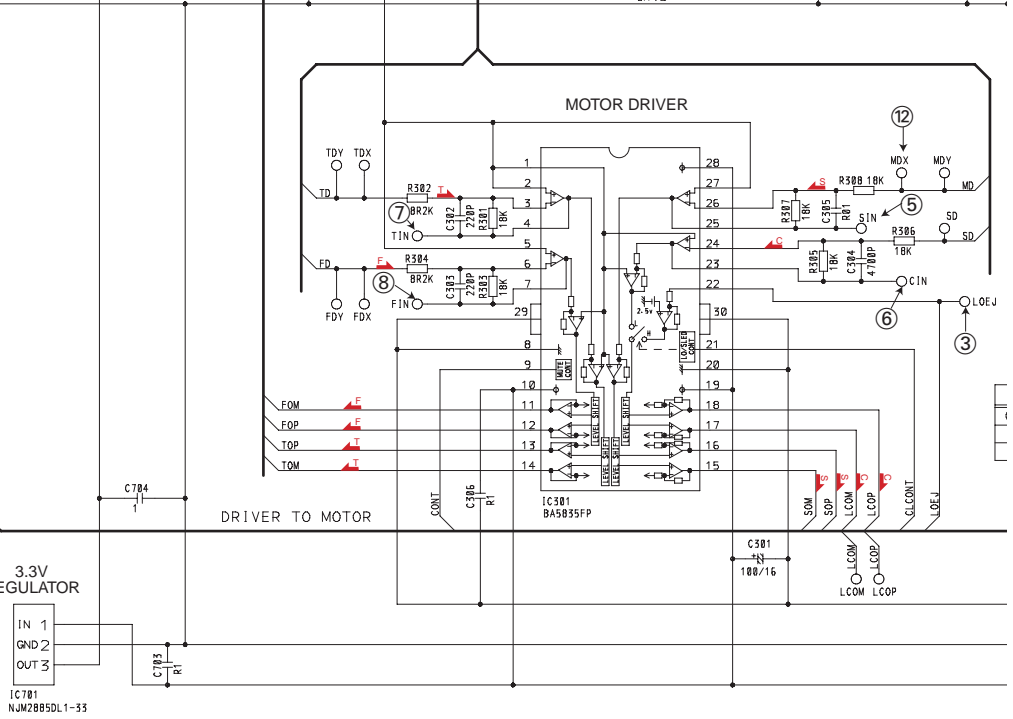
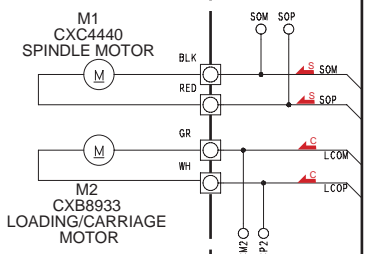
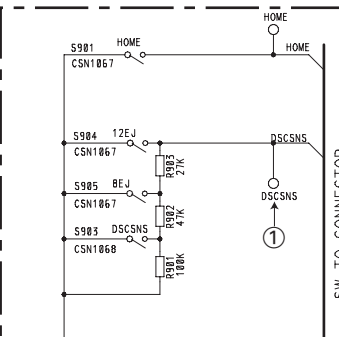

**C**

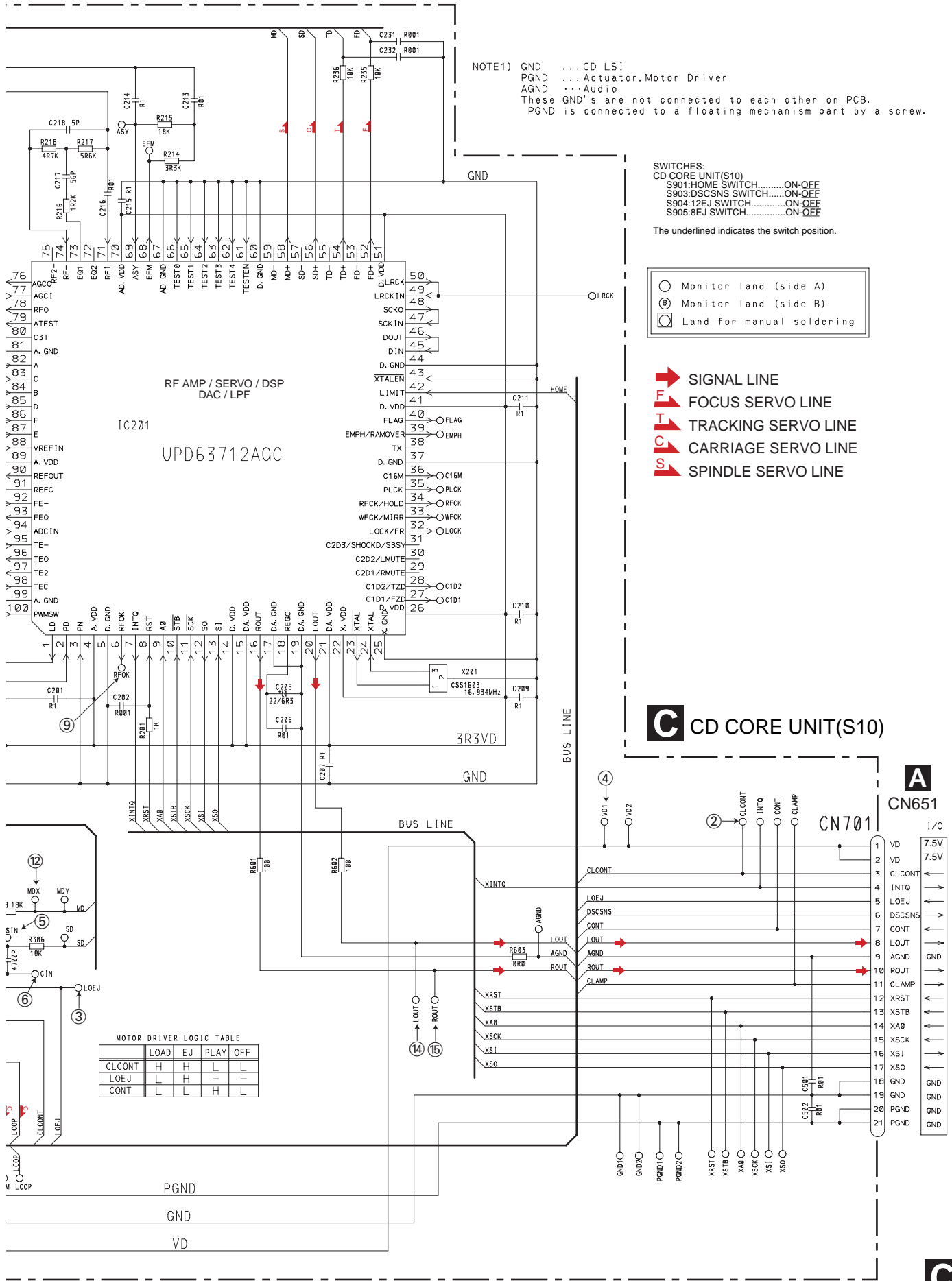

NOTE1) GND ... CD LSI  
 PGND ... Actuator, Motor Driver  
 AGND ... Audio  
 These GND's are not connected to each other on PCB.  
 PGND is connected to a floating mechanism part by a screw.

SWITCHES:  
 CD CORE UNIT(S10)  
 S901:HOME SWITCH.....ON-OFF  
 S903:DSCSNS SWITCH.....ON-OFF  
 S904:12EJ SWITCH.....ON-OFF  
 S905:8EJ SWITCH.....ON-OFF

The underlined indicates the switch position.

- Monitor land (side A)
- ⓑ Monitor land (side B)
- ⓐ Land for manual soldering

- SIGNAL LINE
- FOCUS SERVO LINE
- TRACKING SERVO LINE
- CARRIAGE SERVO LINE
- SPINDLE SERVO LINE

**C** CD CORE UNIT(S10)

MOTOR DRIVER LOGIC TABLE

	LOAD	EJ	PLAY	OFF
CLCONT	H	H	L	L
LOEJ	L	H	-	-
CONT	L	L	H	L

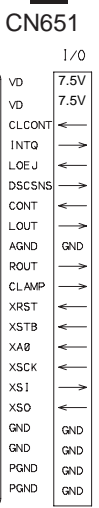

● Waveforms

Note : 1. The encircled numbers denote measuring points in the circuit diagram.  
2. Reference voltage REFO1(1.65V)

A  
B  
C  
D  
E  
F

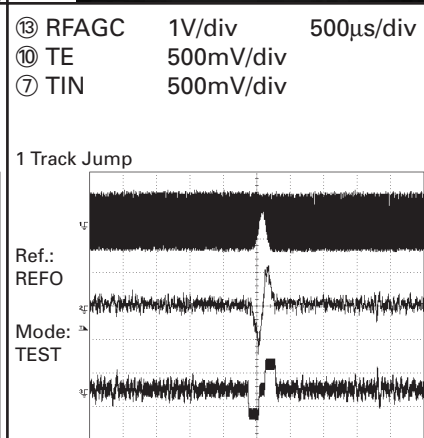
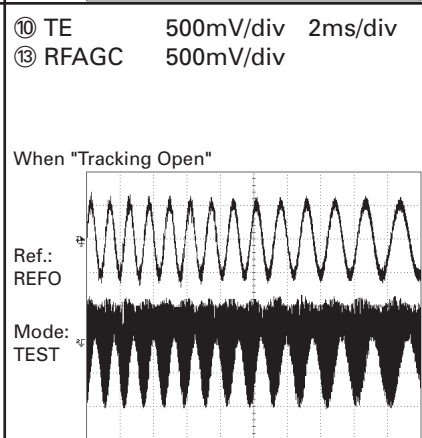
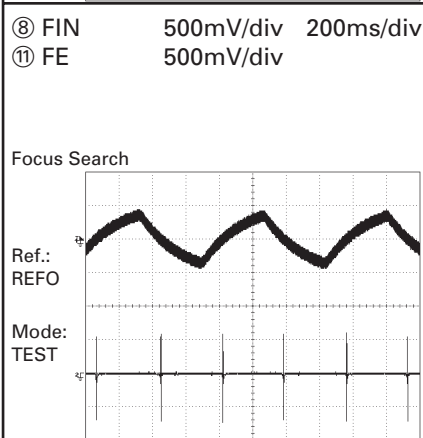
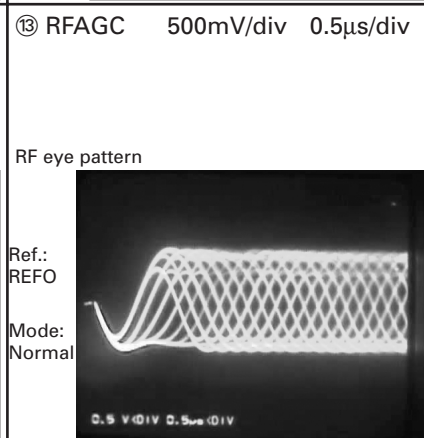
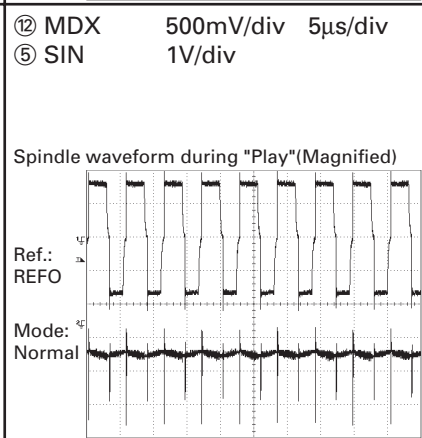
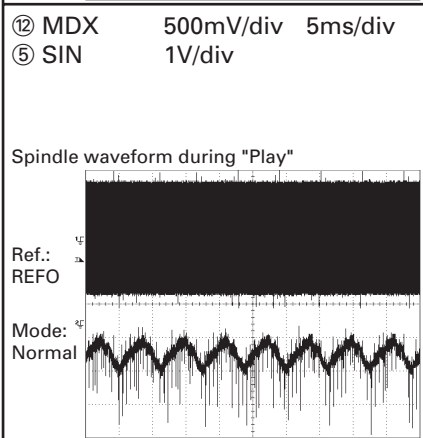
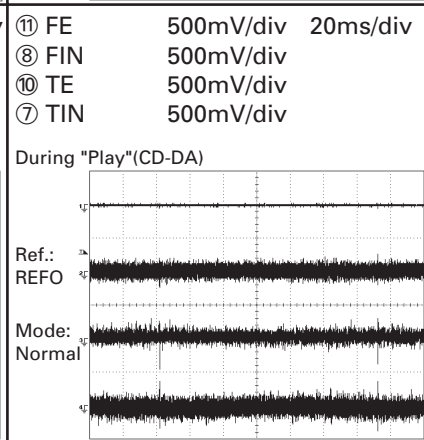
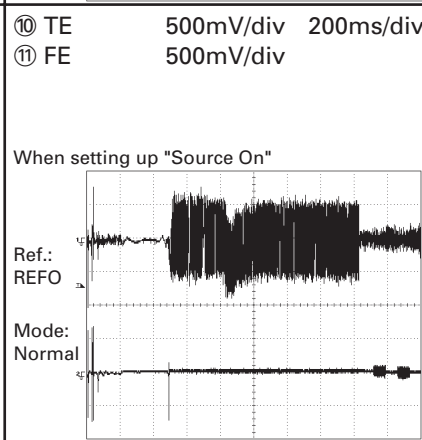
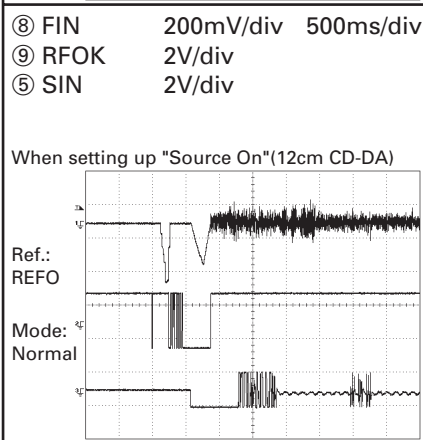
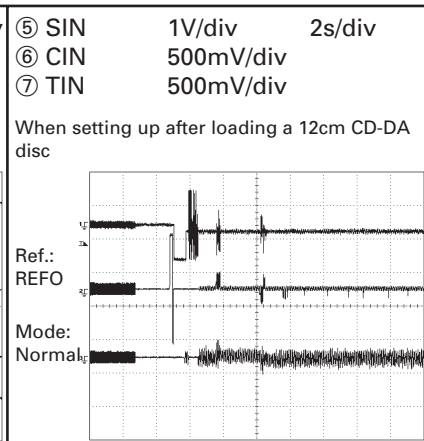
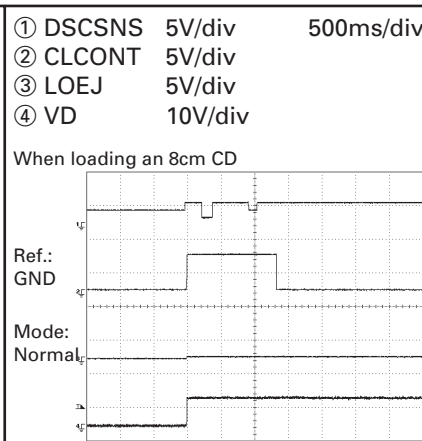
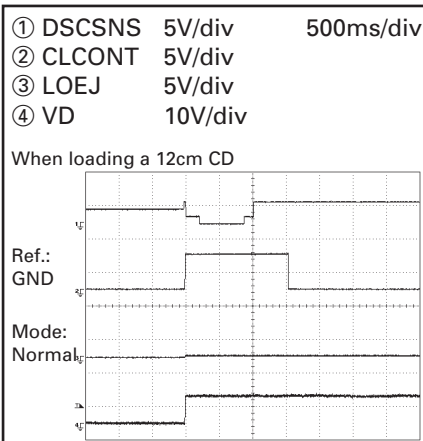

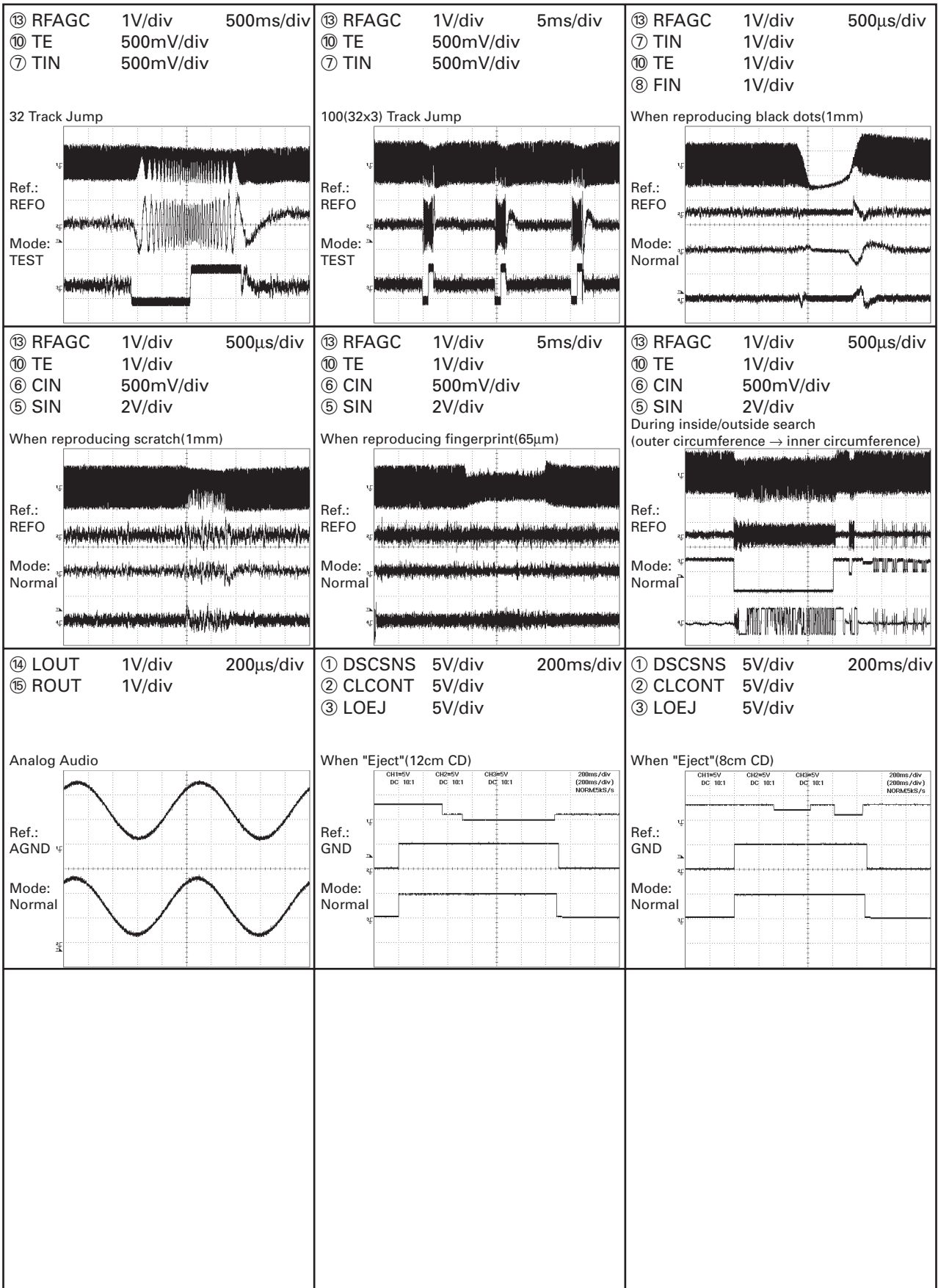

A  
B  
C  
D  
E  
F

# 4. PCB CONNECTION DIAGRAM

## 4.1 TUNER AMP UNIT

### NOTE FOR PCB DIAGRAMS

1. The parts mounted on this PCB include all necessary parts for several destination.  
For further information for respective destinations, be sure to check with the schematic diagram.

2. Viewpoint of PCB diagrams

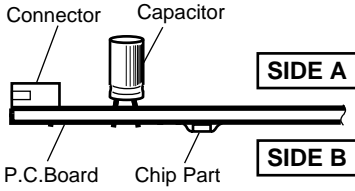

### A TUNER AMP UNIT

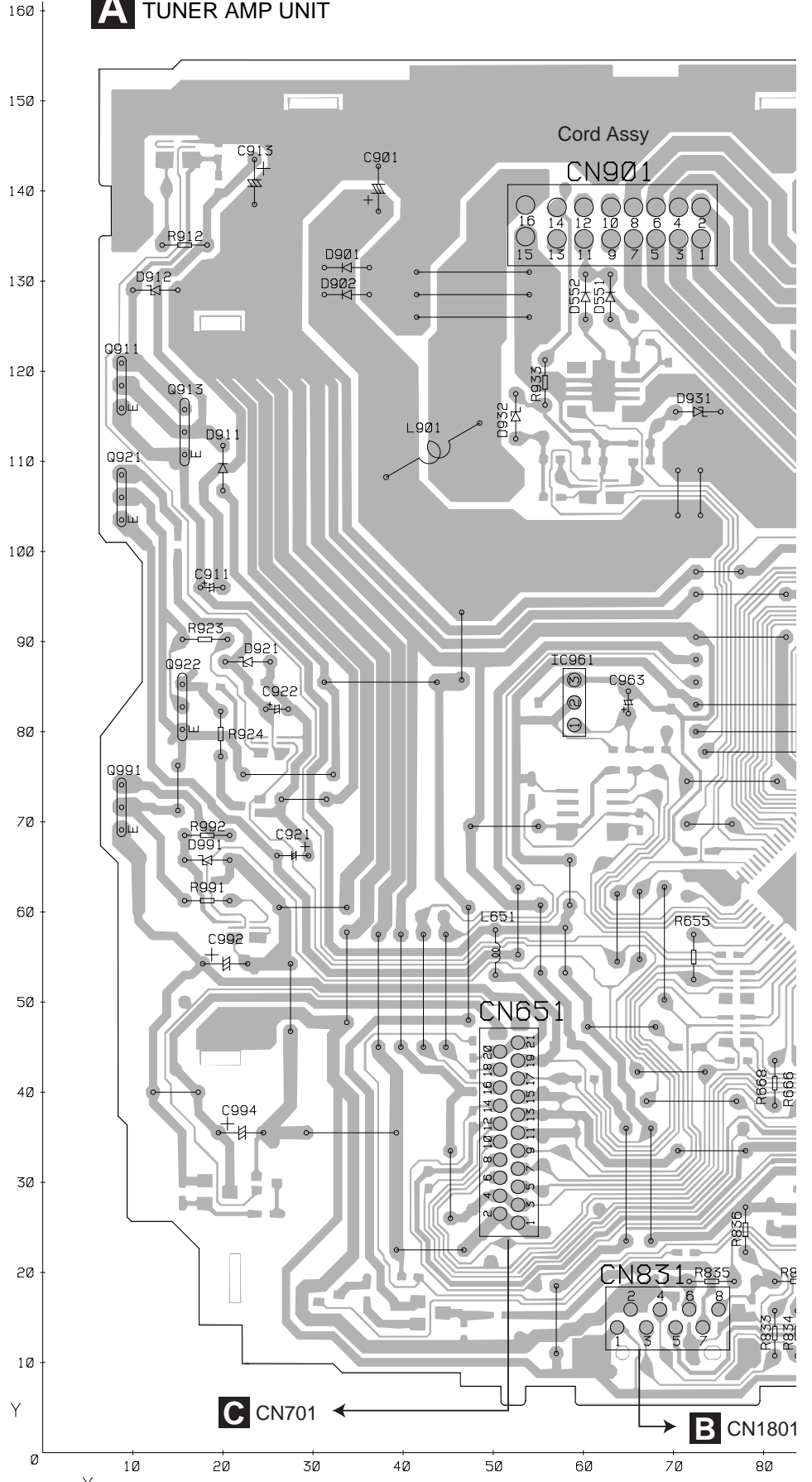

A

SIDE A

A  
B  
C  
D  
E  
F

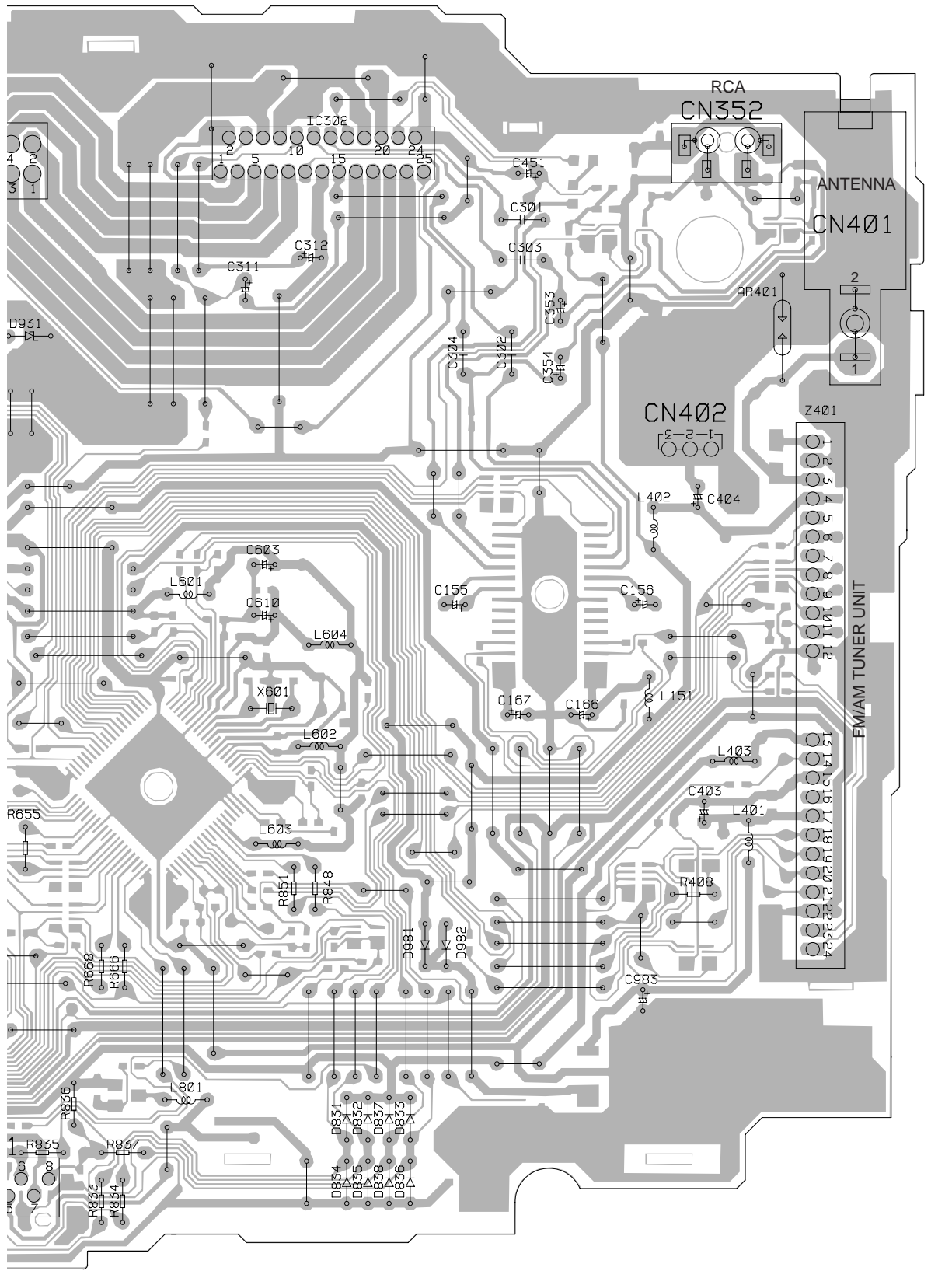

**B** CN1801 FRONT

0 80 90 100 110 120 130 140 150 160 170 180

DEH-1700/XN/UC

**A**

# A TUNER AMP UNIT

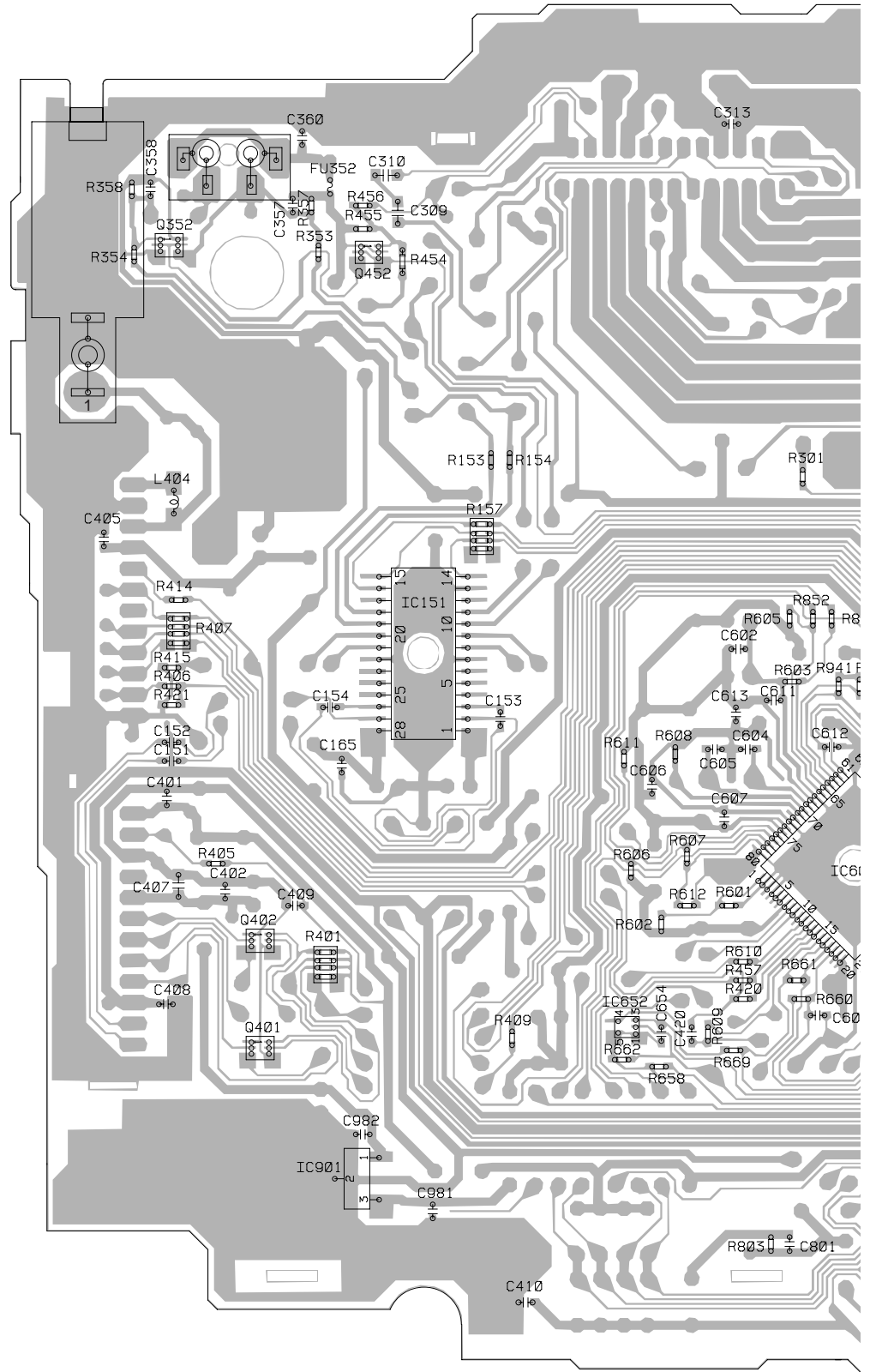

180 170 160 150 140 130 120 110 100 90



SIDE B

A  
B  
C  
D  
E  
F

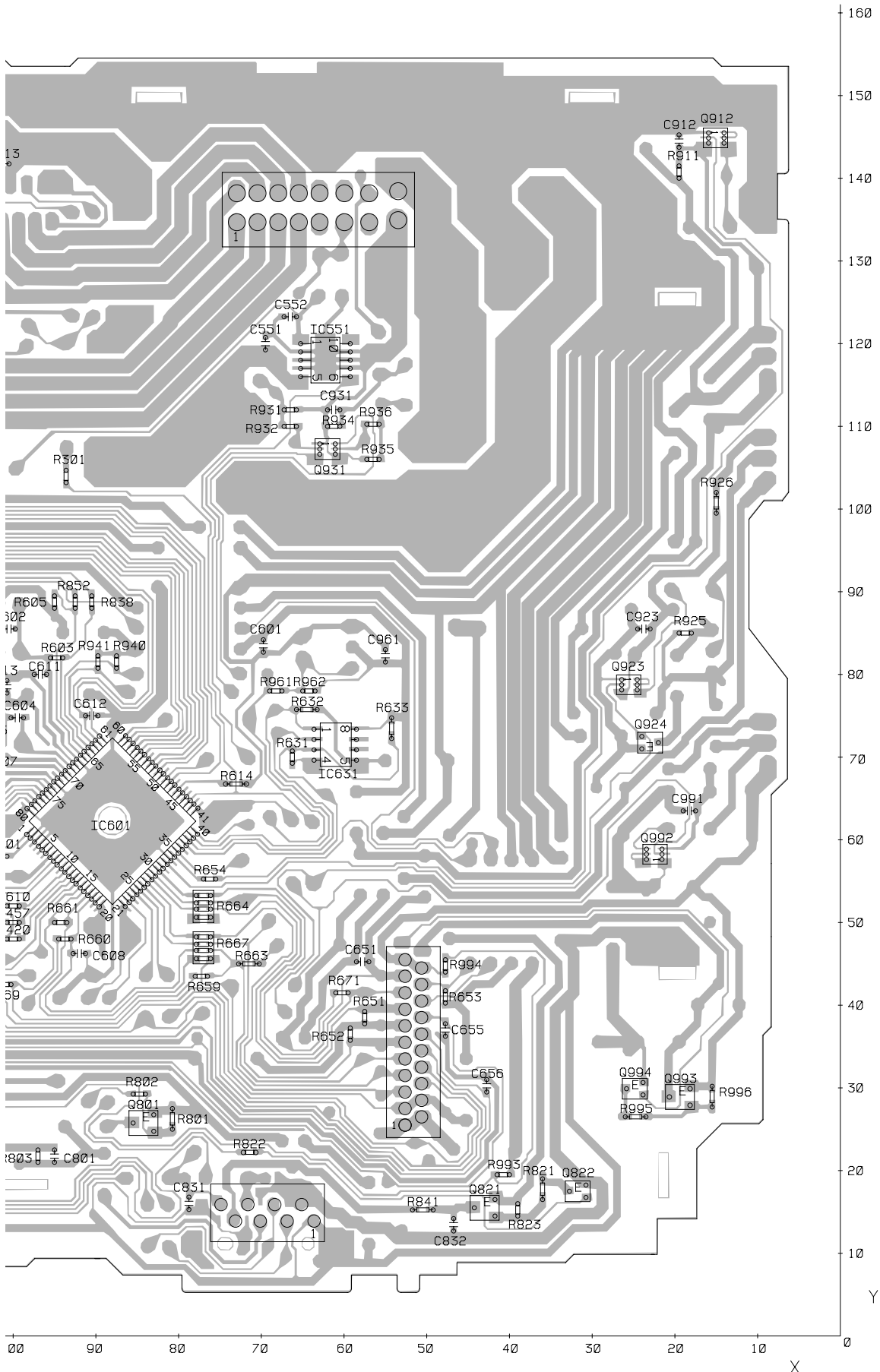

DEH-1700/XN/UC

A

# 4.2 KEYBOARD UNIT

## B KEYBOARD UNIT

SIDE A

A  
B  
C  
D  
E  
F

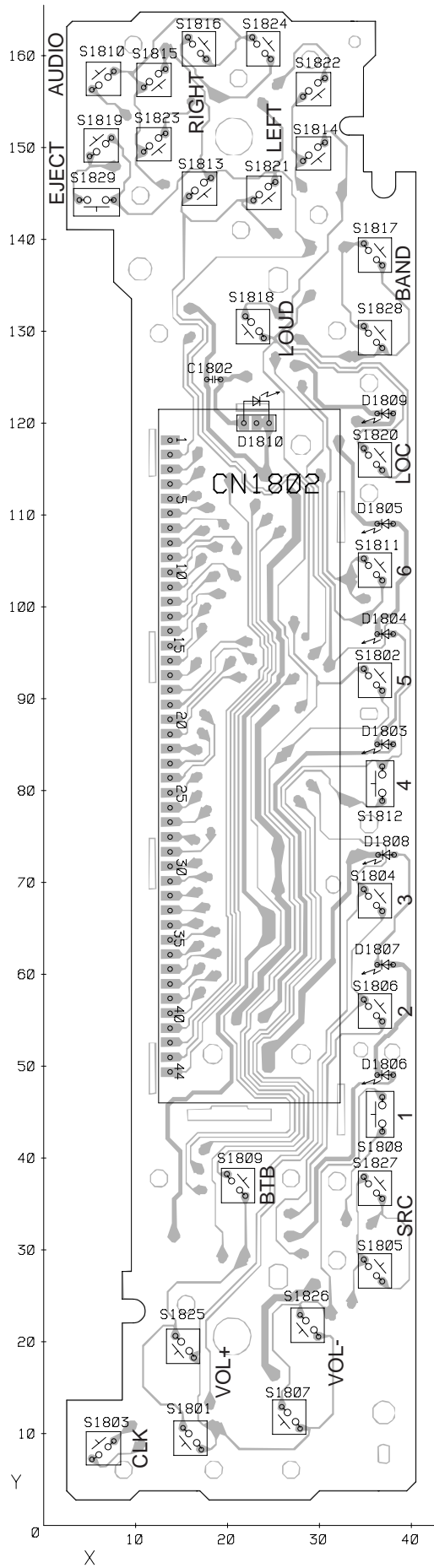

B

# B KEYBOARD UNIT

SIDE B

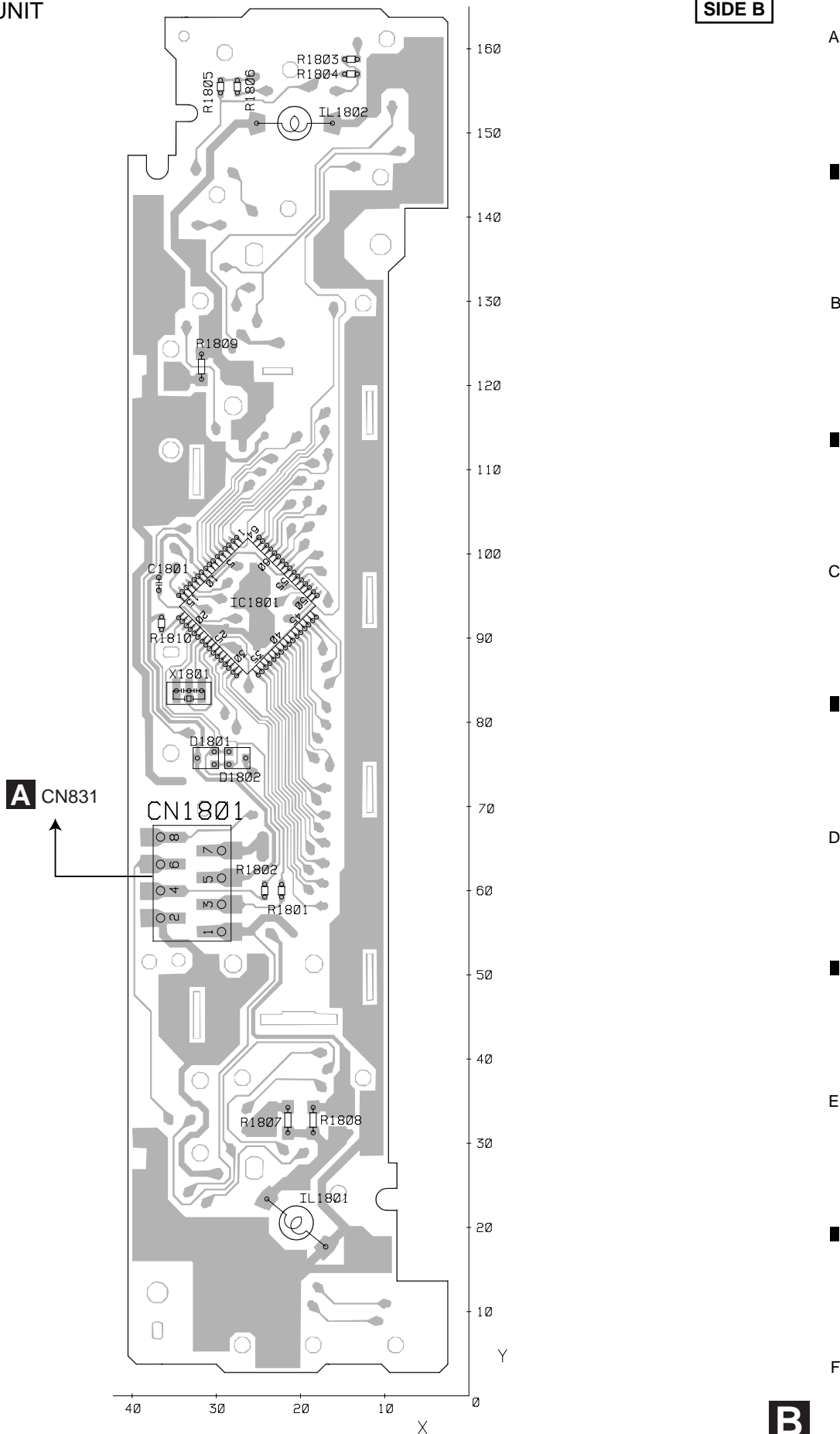

A  
B  
C  
D  
E  
F

**B**

# 4.3 CD CORE UNIT(S10)

## C CD CORE UNIT(S10)

SIDE A

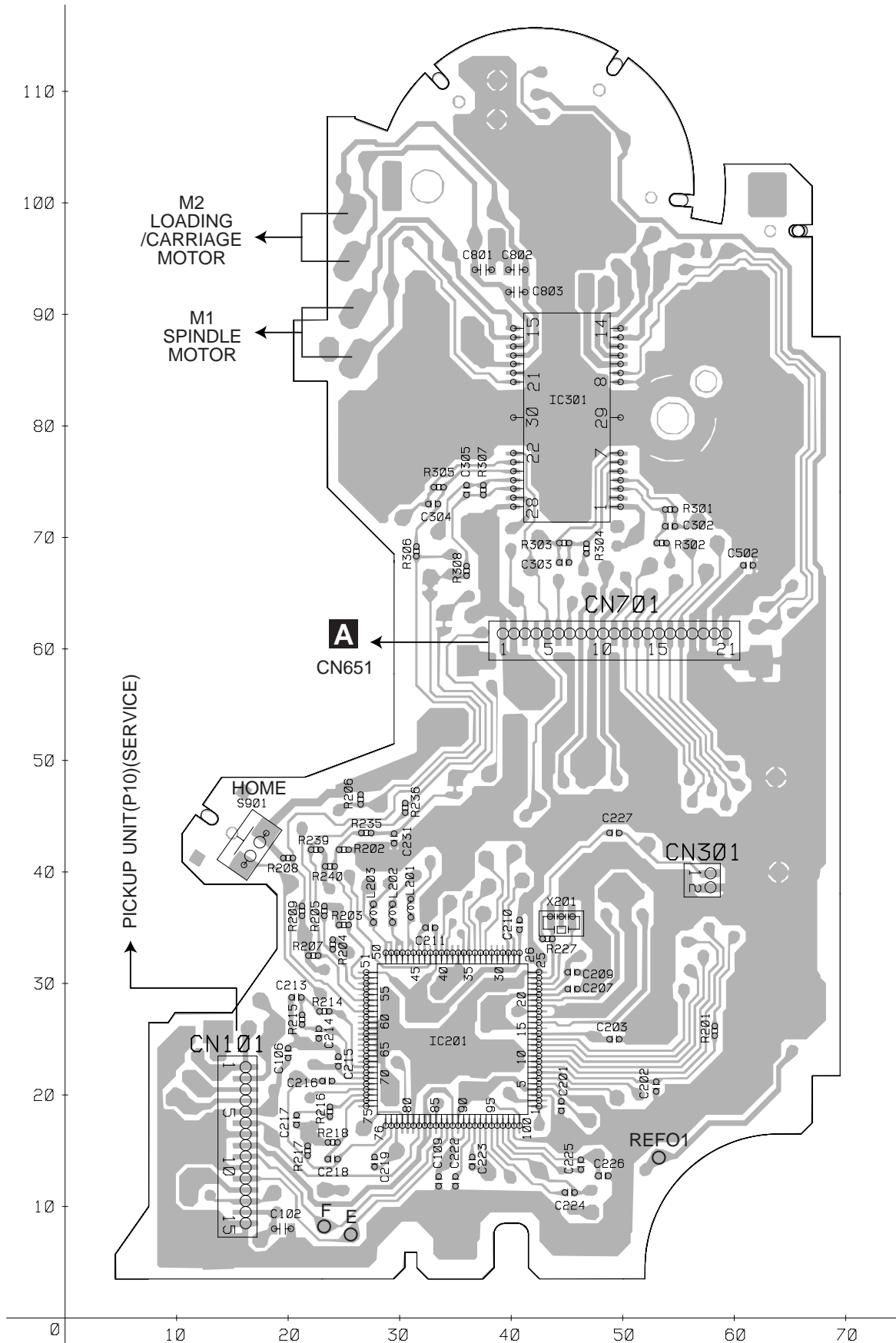

**C** CD CORE UNIT(S10)

**SIDE B**

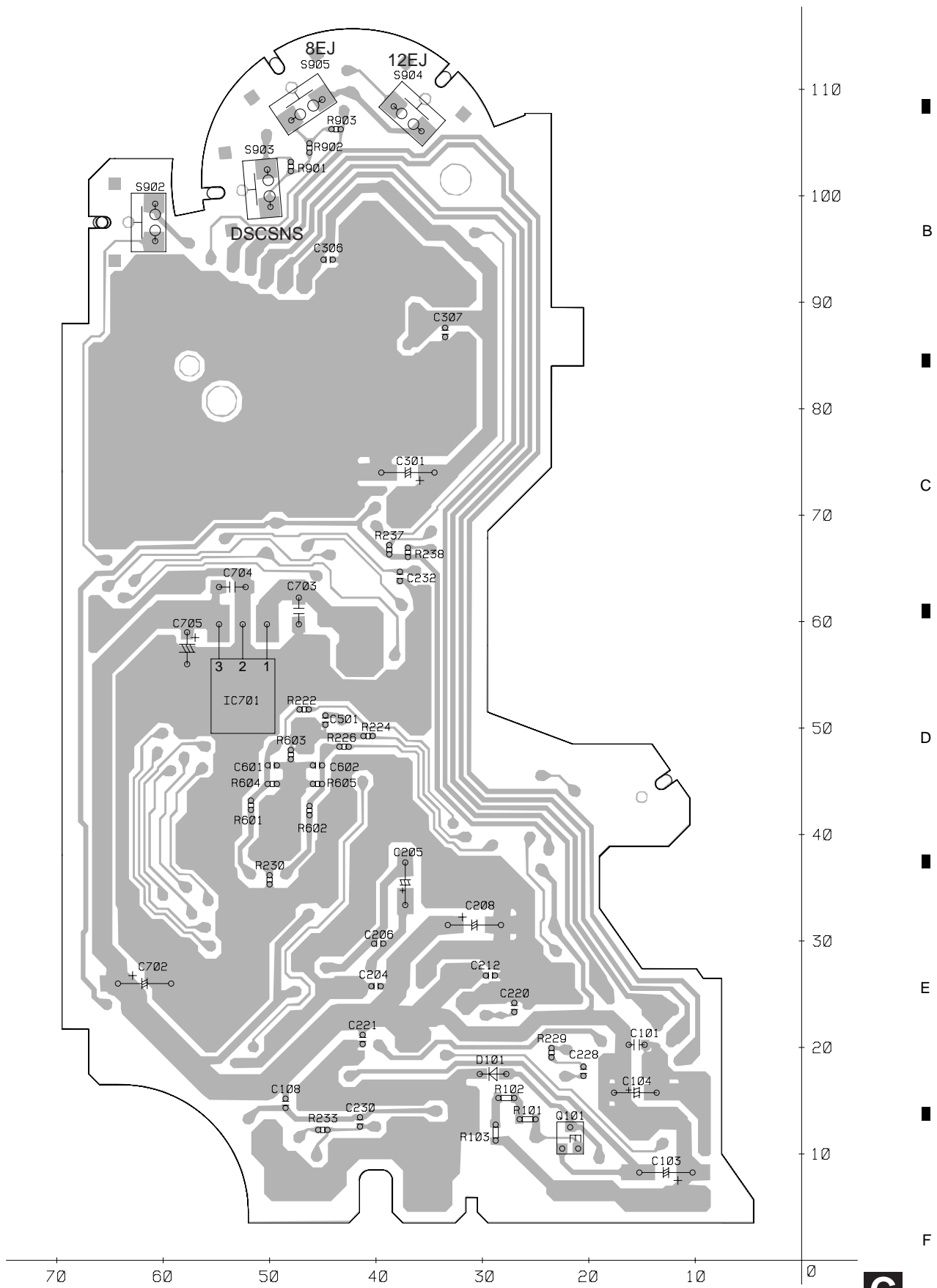

# 5. ELECTRICAL PARTS LIST

**NOTE:**

- Parts whose parts numbers are omitted are subject to being not supplied.
- The part numbers shown below indicate chip components.

*Chip Resistor*

RS1/○S○○○○J,RS1/○○S○○○○J

*Chip Capacitor (except for CQS.....)*

CKS....., CCS....., CSZS.....

- The  $\triangle$  mark found on some component parts indicates the importance of the safety factor of the part. Therefore, when replacing, be sure to use parts of identical designation.

**Circuit Symbol and No.      Part No.      Circuit Symbol and No.      Part No.**

D 991	(A,21,66) Diode	HZS7L(C3)
L 151	(A,146,70) Inductor	LAU2R2K
L 401	(A,158,58) Inductor	LAU2R2K
L 402	(A,147,95) Inductor	LAU2R2K
L 404	(B,161,101) Inductor	LCTAW4R7J2520
L 601	(A,94,85) Ferri-Inductor	LAU100K
L 602	(A,105,67) Inductor	LAU2R2K
L 801	(A,94,25) Inductor	LAU2R2K
L 901	(A,37,108) Choke Coil 600μH	CTH1280
X 601	(A,104,72) Radiator 12.58291MHz	CSS1402
$\triangle$ FU352	(B,144,135) Fuse 3A	CEK1286
AR401	(A,162,110) Surge Protector	DSP-201M-S00B
$\triangle$	Fuse 10A	CEK1208
	FM/AM Tuner Unit	CWE1912



**Unit Number:CWM9604(DEH-1700)**  
**Unit Number:CWM9607(DEH-7)**  
**Unit Name:Tuner Amp Unit**

**MISCELLANEOUS**

IC 151	(B,134,85) IC	PML010A
IC 302	(A,95,135) IC(DEH-1700)	TDA7386
	IC(DEH-7)	TDA7384
IC 551	(B,62,118) IC	TPD1018F
IC 601	(B,88,62) IC	PE5449A
IC 652	(B,113,45) IC	TC7SET08FU
IC 901	(B,144,29) IC	BA33BC0FP
IC 961	(A,59,81) IC	S-80834CNY
Q 352	(B,162,129) Transistor	UMH3N
Q 452	(B,140,128) Transistor	UMD2N
Q 801	(B,84,26) Transistor	2SA1036K
Q 821	(B,43,16) Transistor	2SA1036K
Q 822	(B,32,18) Transistor	DTC114EU
Q 912	(B,15,145) Transistor	UMD2N
Q 913	(A,16,111) Transistor	2SD1859
Q 921	(A,9,104) Transistor	2SD2396
Q 923	(B,26,79) Transistor	UMD2N
Q 931	(B,62,107) Transistor	UMX1N
Q 991	(A,9,69) Transistor	2SD2396
Q 992	(B,23,58) Transistor	UMD2N

**RESISTORS**

R 157	(B,128,98)	RAB4C102J
R 301	(B,94,104)	RS1/16S153J
R 353	(B,146,128)	RS1/16S821J
R 354	(B,165,128)	RS1/16S821J
R 357	(B,146,133)	RS1/16S223J
R 358	(B,166,135)	RS1/16S223J
R 405	(B,157,63)	RS1/16S681J
R 407	(B,161,88)	RAB4C681J
R 414	(B,161,91)	RS1/16S681J
R 420	(B,100,48)	RS1/16S681J
R 421	(B,161,80)	RS1/16S473J
R 454	(B,137,127)	RS1/16S103J
R 455	(B,141,131)	RS1/16S153J
R 456	(B,141,133)	RS1/16S221J
R 457	(B,100,50)	RS1/16S681J
R 601	(B,102,58) (DEH-1700)	RS1/16S473J
R 602	(B,109,56) (DEH-7)	RS1/16S473J
R 603	(B,95,82) (DEH-7)	RS1/16S473J
R 606	(B,112,62)	RS1/16S104J
R 607	(B,106,63)	RS1/16S222J
R 609	(B,104,44)	RS1/16S473J
R 610	(B,100,52)	RS1/16S681J
R 611	(B,113,74)	RS1/16S473J
R 614	(B,73,67)	RS1/16S104J
R 633	(B,54,74)	RS1/16S104J
R 664	(B,77,52)	RAB4C221J
R 666	(A,84,44)	RD1/4PU102J
R 667	(B,77,47)	RAB4C221J
R 668	(A,81,44)	RD1/4PU221J
R 669	(B,101,43)	RS1/16S221J

D 551	(A,63,126) Diode	MPG06G-6415G3
D 552	(A,60,126) Diode	MPG06G-6415G3
D 831	(A,110,21) Diode(DEH-1700)	1SS270
D 832	(A,113,21) Diode(DEH-1700)	1SS270
D 833	(A,118,21) Diode(DEH-1700)	1SS270
D 834	(A,110,13) Diode(DEH-1700)	1SS270
D 835	(A,113,13) Diode(DEH-1700)	1SS270
D 836	(A,118,13) Diode(DEH-1700)	1SS270
D 837	(A,115,21) Diode(DEH-1700)	1SS270
D 838	(A,115,13) Diode(DEH-1700)	1SS270
D 901	(A,36,132) Diode	MPG06G-6415G3
D 902	(A,36,129) Diode	MPG06G-6415G3
D 911	(A,20,107) Diode	MPG06G-6415G3
D 912	(A,15,129) Diode	HZS6L(B2)
D 921	(A,25,88) Diode	HZS9L(B3)
D 931	(A,70,116) Diode	HZS7L(C3)
D 932	(A,53,113) Diode	HZS7L(A1)

<u>Circuit Symbol and No.</u>		<u>Part No.</u>	<u>Circuit Symbol and No.</u>		<u>Part No.</u>
R 801	(B,81,26)	RS1/16S153J	C 405	(B,169,97)	CKSRYB103K50
R 802	(B,85,29)	RS1/16S153J	C 409	(B,148,58)	CCSRCH470J50
R 803	(B,97,22)	RS1/16S222J	C 420	(B,106,44)	CCSRCH470J50
R 821	(B,36,18)	RS1/16S562J	C 451	(A,133,135)	CEJQ330M10
R 822	(B,71,22)	RS1/16S102J	C 551	(B,70,120)	CKSRYB103K50
R 823	(B,39,15)	RS1/16S103J	C 552	(B,67,123)	CKSRYB103K50
R 833	(A,81,11)	RD1/4PU222J	C 601	(B,70,83)	CKSRYB103K50
R 834	(A,84,11)	RD1/4PU222J	C 603	(A,102,89)	CEJQ4R7M35
R 835	(A,72,19)	RD1/4PU102J	C 604	(B,100,75)	CCSRCH200J50
R 836	(A,78,22) (DEH-1700)	RD1/4PU104J	C 605	(B,103,75)	CCSRCH200J50
R 837	(A,81,19) (DEH-1700)	RD1/4PU103J	C 606	(B,110,71)	CKSRYB104K16
R 838	(B,91,89) (DEH-1700)	RS1/16S102J	C 607	(B,102,67)	CCSRCH101J50
R 841	(B,50,15)	RS1/16S1R0J	C 610	(A,102,83)	CEJQ4R7M35
R 848	(A,107,48)	RD1/4PU102J	C 611	(B,97,80)	CKSRYB224K10
R 851	(A,104,48)	RD1/4PU102J	C 654	(B,109,44)	CKSRYB104K16
R 852	(B,93,89)	RS1/16S102J	C 801	(B,95,22)	CKSRYB104K16
R 911	(B,20,141)	RS1/16S223J	C 832	(B,47,13) (DEH-1700)	CKSRYB104K16
R 912	(A,13,134)	RD1/4PU152J	C 901	(A,37,140)	CEAT332M16(P45)
R 923	(A,21,90)	RD1/4PU821J	C 911	(A,18,96)	CEJQ470M10
R 926	(B,15,101)	RS1/16S221J	C 912	(B,20,145)	CKSRYB103K50
R 931	(B,67,112)	RS1/16S473J	C 913	(A,24,144)	CEAT221M16
R 932	(B,67,110)	RS1/16S104J	C 921	(A,26,66) 330µF/16V	CCH1326
R 933	(A,56,116)	RD1/4PU102J	C 922	(A,25,83)	CEJQ101M16
R 934	(B,61,110)	RS1/16S472J	C 923	(B,24,86)	CKSRYB103K50
R 935	(B,57,106)	RS1/16S473J	C 961	(B,55,82)	CKSRYB473K50
R 936	(B,57,110)	RS1/16S223J	C 963	(A,65,82)	CEJQ100M16
R 940	(B,88,82)	RS1/16S104J	C 981	(B,133,25)	CKSRYB334K10
R 941	(B,90,82)	RS1/16S104J	C 983	(A,145,38)	CEJQ470M10
R 961	(B,68,78)	RS1/16S102J	C 991	(B,18,64)	CKSRYB473K50
R 962	(B,64,78)	RS1/16S822J	C 992	(A,18,54)	CEJQ101M10
R 991	(A,21,61)	RD1/4PU271J			
R 992	(A,16,69)	RD1/4PU221J			
R 993	(B,41,20)	RS1/16S222J			
R 994	(B,48,45)	RS1/16S472J			

**CAPACITORS**

C 151	(B,161,74)	CKSRYB224K10
C 152	(B,161,76)	CKSRYB224K10
C 153	(B,126,78)	CKSRYB105K6R3
C 154	(B,144,79)	CKSRYB105K6R3
C 155	(A,124,84)	CEJQ4R7M35
C 156	(A,144,84)	CEJQ4R7M35
C 165	(B,143,73)	CKSRYB104K16
C 166	(A,139,71)	CEJQ470M10
C 167	(A,129,71)	CEJQ100M16
C 301	(A,134,129)	CFTNA224J50
C 302	(A,130,111)	CFTNA224J50
C 303	(A,134,125)	CFTNA224J50
C 304	(A,124,111)	CFTNA224J50
C 309	(B,137,132)	CKSQYB225K10
C 310	(B,138,136)	CKSQYB225K10
C 311	(A,98,122)	CEJQ2R2M50
C 312	(A,105,125)	CEJQ100M16
C 313	(B,101,142)	CKSRYB104K16
C 353	(A,136,120)	CEJQ2R2M50
C 354	(A,136,111)	CEJQ2R2M50
C 401	(B,162,70)	CKSRYB103K50
C 402	(B,156,60)	CKSRYB103K50
C 403	(A,153,58)	CEJQ470M6R3
C 404	(A,152,95)	CEJQ101M10

**B**  
**Unit Number:CWM9620(DEH-1700)**  
**Unit Number:CWM9844(DEH-7)**  
**Unit Name:Keyboard Unit**

**MISCELLANEOUS**

IC 1801	(B,26,94) IC	PD6340A
D 1803	(A,37,85) LED	SML-310PT
D 1804	(A,37,97) LED	SML-310PT
D 1805	(A,37,109) LED	SML-310PT
D 1806	(A,37,49) LED	SML-310PT
D 1807	(A,37,61) LED	SML-310PT
D 1808	(A,37,73) LED	SML-310PT
D 1809	(A,37,121) LED	SML-310PT
D 1810	(A,23,120) LED	CL-490S-WF-SD
X 1801	(B,33,84) Ceramic Resonator 5.00MHz	CSS1547
IL 1801	(B,21,21) Lamp 40mA,14V	CEL1651
IL 1802	(B,21,151) Lamp 40mA,14V LCD	CEL1651 CAW1848

**RESISTORS**

R 1801	(B,22,60)	RS1/16S222J
R 1802	(B,24,60)	RS1/16S222J
R 1804	(B,14,157)	RS1/16S0R0J
R 1806	(B,28,156)	RS1/16S0R0J
R 1807	(B,22,33)	RS1/4SA471J
R 1808	(B,19,33)	RS1/4SA471J

**Circuit Symbol and No.****Part No.**

R 1809	(B,32,122)	RS1/4SA471J
R 1810	(B,37,92)	RS1/16S104J

**Circuit Symbol and No.****Part No.**

C 211	(A,33,35)	CKSSYB104K10
C 213	(A,21,29)	CKSSYB103K16
C 214	(A,23,26)	CKSSYB104K10
C 215	(A,25,23)	CKSSYB104K10
C 216	(A,24,21)	CKSSYB103K16
C 217	(A,21,18)	CCSSCH560J50
C 218	(A,24,14)	CCSSCH5R0C50
C 219	(A,28,14)	CKSSYB104K10
C 220	(B,27,24)	CKSSYB104K10
C 221	(B,41,21)	CKSSYB104K10
C 222	(A,35,12)	CKSSYB103K16

**A CAPACITORS**

C 1801	(B,37,96)	CKSRYB103K50
C 1802	(A,19,125)	CKSRYF104Z25

**C****Unit Number: CWX3110****Unit Name: CD Core Unit(S10)****MISCELLANEOUS**

IC 201	(A,35,25) IC	UPD63712AGC
IC 301	(A,45,81) IC	BA5835FP
IC 701	(B,53,56) IC	NJM2885DL1-33
Q 101	(B,22,12) Transistor	2SA1577
X 201	(A,45,36) Ceramic Resonator 16.934MHz	CSS1603

C 223	(A,37,14)	CCSSCH680J50
C 224	(A,45,11)	CCSSCH470J50
C 225	(A,46,14)	CKSSYB103K16
C 231	(A,30,43)	CKSSYB102K50
C 232	(B,38,64)	CKSSYB102K50

C 301	(B,37,74) 100µF/16V	CCH1504
C 302	(A,54,71)	CKSSYB221K50
C 303	(A,45,68)	CKSSYB221K50
C 304	(A,33,73)	CKSSYB472K25
C 305	(A,36,74)	CKSSYB103K16
C 306	(B,45,94)	CKSSYB104K10
C 501	(B,45,51)	CKSSYB103K16
C 502	(A,61,68)	CKSSYB103K16
C 703	(B,47,61)	CKSQYB104K16
C 704	(B,54,63)	CKSQYB105K10

S 901	(A,15,44) Switch(HOME)	CSN1067
S 903	(B,53,101) Switch(DSCSNS)	CSN1068
S 904	(B,35,109) Switch(12EJ)	CSN1067
S 905	(B,48,110) Switch(8EJ)	CSN1067

**RESISTORS**

R 101	(B,26,13)	RS1/10SR2R4J
R 102	(B,28,15)	RS1/10SR2R4J
R 103	(B,29,12)	RS1/10SR2R7J
R 201	(A,58,26)	RS1/16SS102J
R 214	(A,23,28)	RS1/16SS332J

**Miscellaneous Parts List**

M 1	Pickup Unit(P10)(Service)	CXX1641
M 2	Motor Unit(SPINDLE)	CXC4440
	Motor Unit(LOADING/CARRIAGE)	CXB8933

R 215	(A,21,27)	RS1/16SS183J
R 216	(A,24,19)	RS1/16SS122J
R 217	(A,22,15)	RS1/16SS562J
R 218	(A,24,16)	RS1/16SS472J
R 235	(A,27,44)	RS1/16SS103J

R 236	(A,31,46)	RS1/16SS103J
R 301	(A,54,73)	RS1/16SS183J
R 302	(A,54,70)	RS1/16SS822J
R 303	(A,45,70)	RS1/16SS183J
R 304	(A,47,69)	RS1/16SS822J

R 305	(A,34,75)	RS1/16SS183J
R 306	(A,32,69)	RS1/16SS183J
R 307	(A,38,74)	RS1/16SS183J
R 308	(A,36,67)	RS1/16SS183J
R 601	(B,52,43)	RS1/16SS101J

R 602	(B,46,42)	RS1/16SS101J
R 603	(B,48,48)	RS1/16SS0R0J
R 901	(B,48,103)	RS1/16SS104J
R 902	(B,46,105)	RS1/16SS473J
R 903	(B,44,106)	RS1/16SS273J

**CAPACITORS**

C 103	(B,13,8) 100µF/16V	CCH1504
C 109	(A,34,12)	CKSSYB104K10
C 201	(A,45,19)	CKSSYB104K10
C 202	(A,53,21)	CKSSYB102K50
C 205	(B,37,36) 22µF/6.3V	CCH1507

F C 206	(B,40,30)	CKSSYB103K16
C 207	(A,46,30)	CKSSYB104K10
C 209	(A,46,31)	CKSSYB104K10
C 210	(A,41,35)	CKSSYB104K10



# 6. ADJUSTMENT

## 6.1 CD ADJUSTMENT

### 1) Cautions on adjustments

• In this product the single voltage (3.3V) is used for the regulator. The reference voltage is the REFO1 (1.65V) instead of the GND.

If you should mistakenly short the REFO1 with the GND during adjustment, accurate voltage will not be obtained, and the servo's misoperation will apply excessive shock to the pickup. To avoid such problems:

a. Do not mix up the REFO1 with the GND when connecting the (-) probe of measuring instruments. Especially on an oscilloscope, avoid connecting the (-) probe for CH1 to the GND.

b. In many cases, measuring instruments have the same potential as that for the (-) probe. Be sure to set the measuring instruments to the floating state.

c. If you have mistakenly connected the REFO1 to the GND, turn off the regulator or the power immediately.

• Before mounting and removing filters or leads for adjustment, be sure to turn off the regulator.

• For stable circuit operation, keep the mechanism operating for about one minute or more after the regulator is turned on.

• In the test mode, any software protections will not work. Avoid applying any mechanical or electrical shock to the mechanism during adjustment.

• The RFI and RFO signals with a wide frequency range are easy to oscillate. When observing the signals, insert a resistor of 1k ohms in series.

• The load and eject operation is not guaranteed with the mechanism upside down. If the mechanism is blocked due to mistaken eject operation, reset the product or turn off and on the ACC to restore it.

### 2) Test mode

This mode is used to adjust the CD mechanism module.

• To enter the test mode.

While pressing the 4 and 6 keys at the same time, reset.

• To exit from the test mode.

Turn off the ACC and back up.

#### Notes:

a. During ejection, do not press any other keys than the EJECT key until the loaded disc is ejected.

b. If you have pressed the (→) key or (←) key during focus search, turn off the power immediately to protect the actuator from damage caused by the lens stuck.

c. For the TR jump modes except 100TR, the track jump operation will continue even if the key is released.

d. For the CRG move and 100TR jump modes, the tracking loop will be closed at the same time when the key is released.

e. When the power is turned off and on, the jump mode is reset to the single TR (91), the RF amp gain is set to 0dB, and the auto-adjustment values are reset to the default settings.

● Flow Chart

A

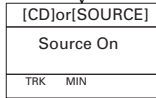
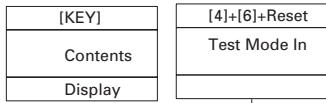

B

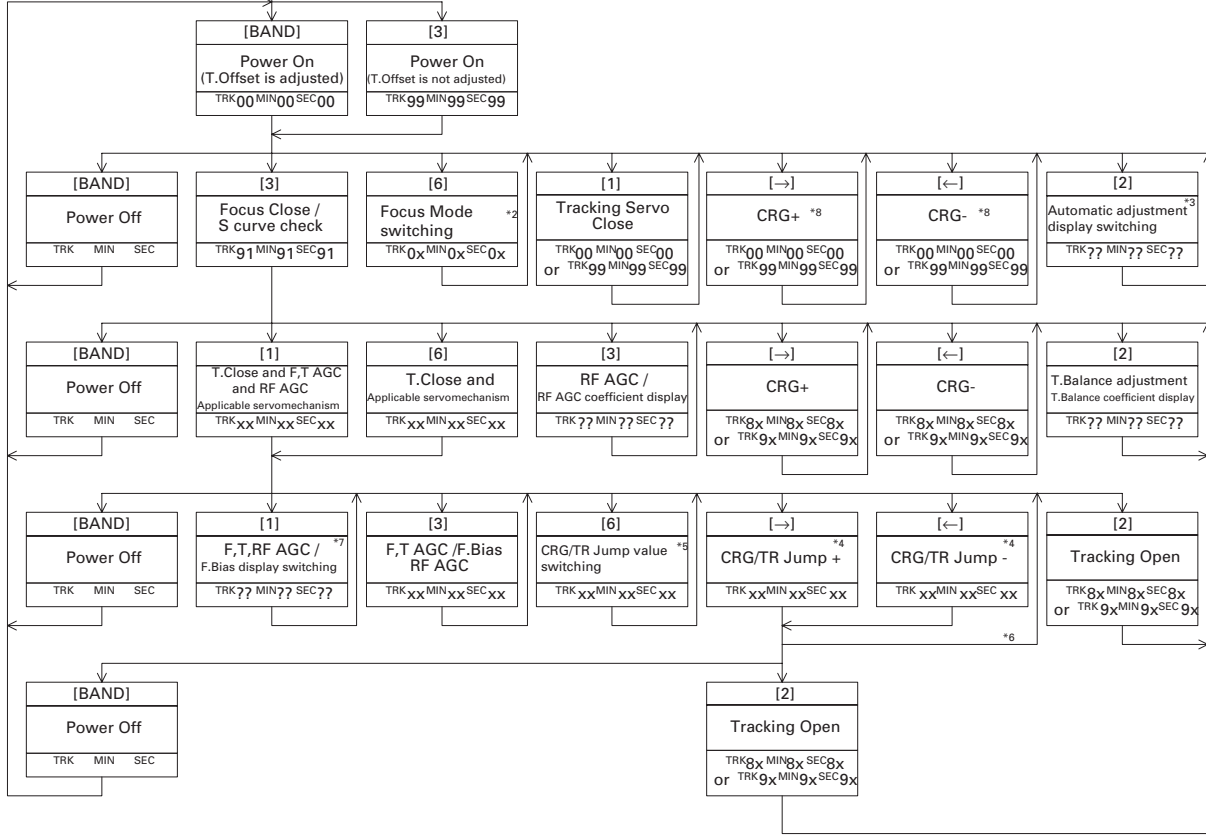

C

D

\*1) 

TRK	TYP	→	-12dB
MIN	MIN	MIN	TRK 12 MIN 12 SEC 12
SEC	SEC	SEC	

\*2) Focus Close → S.Curve → F EQ measurement setting  
 TRK 00 MIN 00 SEC 00 TRK 01 MIN 01 SEC 01 TRK 02 MIN 02 SEC 02  
 (TRK 99 MIN 99 SEC 99)

\*3) F.Offset Display → RF.Offset Display → T.Offset Display

\*4) 1TR/32TR/100TR

\*5) Single TR → 32TR → 100TR → CRG Move  
 9x(8x) : 91(81) 92(82) 93(83) 94(84)

\*6) Only at the time of CRG Move or 100TR Jump  
 \*7) TRK/MIN/SEC → F.AGC → T.AGC Gain → F.bias → RF AGC

\*8) CRG motor voltage = 2[V]

E

[Key]	Operation
	Test Mode
[BAND]	Power On / Off
[→]	CRG + / TR Jump + (Direction of the external surface)
[←]	CRG - / TR Jump - (Direction of the internal surface)
[1]	CLS and AGC and Applicable servomechanism / AGC, AGC display switching
[2]	RF Gain switching / Offset adjustment display / T.Balance adjustment / T.Open
[3]	Close, S.Curve / Rough Servo and RF AGC / F, T, RF AGC
-	SPDL 1X / 2X switching (Double-speed compatibility only)
-	Gop measurement
[6]	Focus Mode switching / Tracking Close / CRG, TR Jump switching

F

## 6.2 CHECKING THE GRATING AFTER CHANGING THE PICKUP UNIT



### • Note :

The grating angle of the PU unit cannot be adjusted after the PU unit is changed. The PU unit in the CD mechanism module is adjusted on the production line to match the CD mechanism module and is thus the best adjusted PU unit for the CD mechanism module. Changing the PU unit is thus best considered as a last resort. However, if the PU unit must be changed, the grating should be checked using the procedure below.

### • Purpose :

To check that the grating is within an acceptable range when the PU unit is changed.

### • Symptoms of Mal-adjustment :

If the grating is off by a large amount symptoms such as being unable to close tracking, being unable to perform track search operations, or taking a long time for track searching.

### • Method :

- |                       |                            |
|-----------------------|----------------------------|
| • Measuring Equipment | • Oscilloscope, Two L.P.F. |
| • Measuring Points    | • E, F, REFO1              |
| • Disc                | • TCD-782                  |
| • Mode                | • TEST MODE                |

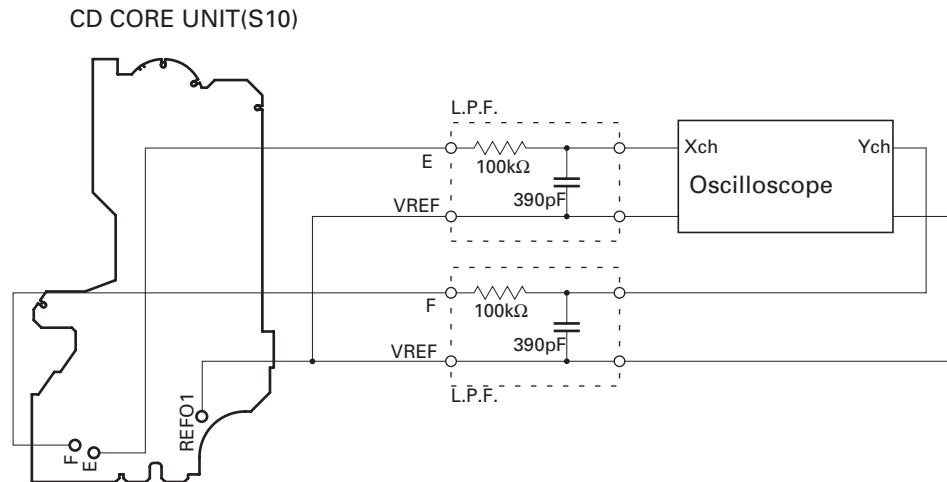

### • Checking Procedure

1. In test mode, load the disc and switch the 3V regulator on.
2. Using the → and ← buttons, move the PU unit to the innermost track.
3. Press key 3 to close focus, the display should read "91". Press key 2 to implement the tracking balance adjustment the display should now read "81". Press key 3. The display will change, returning to "81" on the fourth press.
4. As shown in the diagram above, monitor the LPF outputs using the oscilloscope and check that the phase difference is within  $75^\circ$ . Refer to the photographs supplied to determine the phase angle.
5. If the phase difference is determined to be greater than  $75^\circ$  try changing the PU unit to see if there is any improvement. If, after trying this a number of times, the grating angle does not become less than  $75^\circ$  then the mechanism should be judged to be at fault.

### • Note

Because of eccentricity in the disc and a slight misalignment of the clamping center the grating waveform may be seen to "wobble" ( the phase difference changes as the disc rotates). The angle specified above indicates the average angle.

### • Hint

Reloading the disc changes the clamp position and may decrease the "wobble".

### Grating waveform

Ech → Xch 20mV/div, AC  
Fch → Ych 20mV/div, AC

A

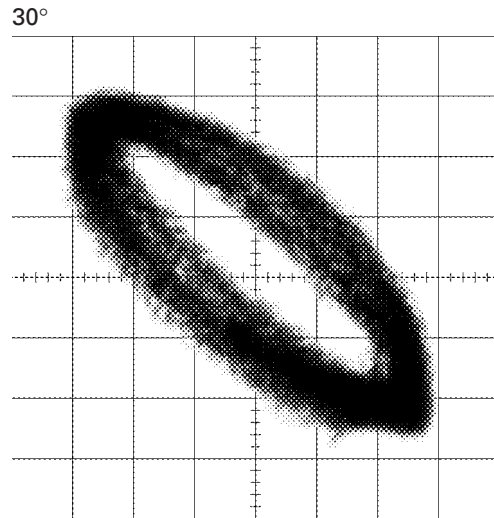
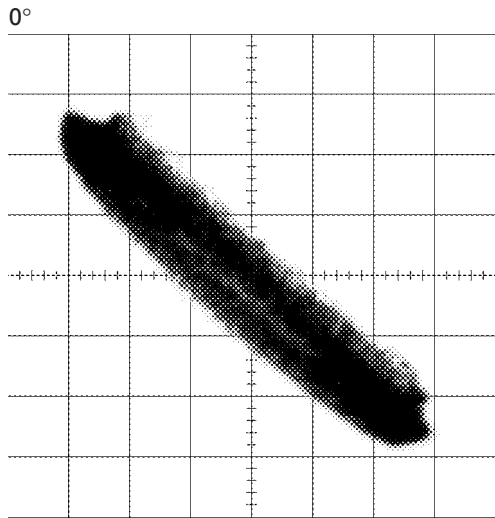

B

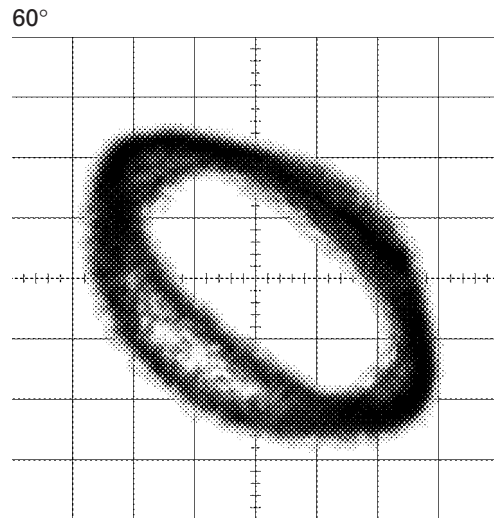
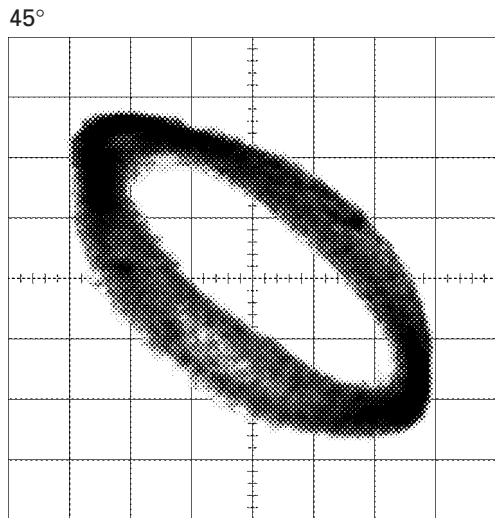

C

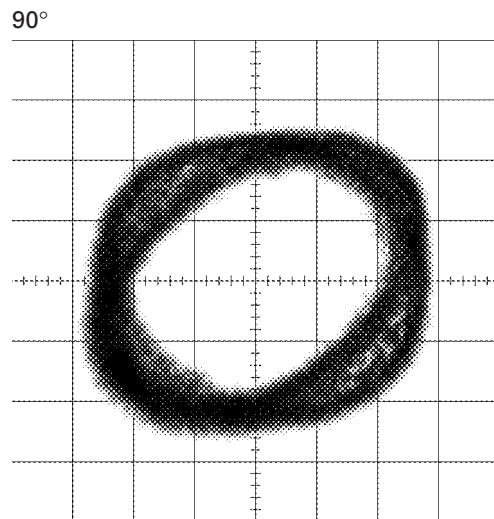
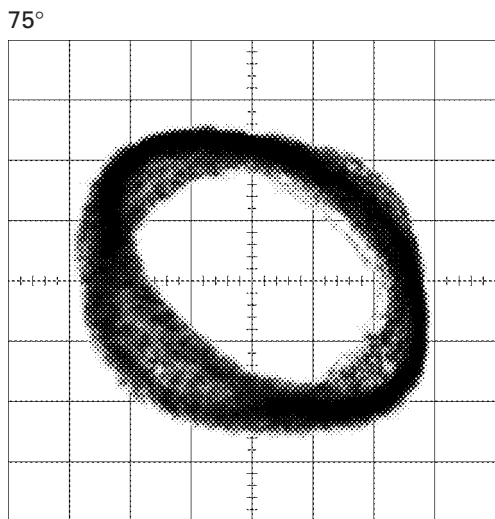

D

E

F

## 6.3 ERROR MODE

### ● Error Messages

If a CD is not operative or stopped during operation due to an error, the error mode is turned on and cause(s) of the error is indicated with a corresponding number. This arrangement is intended at reducing nonsense calls from the users and also for facilitating trouble analysis and repair work in servicing.

#### (1) Basic Indication Method

1) When SERRORM is selected for the CSMOD (CD mode area for the system), error codes are written to DMIN (minutes display area) and DSEC (seconds display area). The same data is written to DMIN and DSEC. DTNO remains in blank as before.

#### 2) Head unit display examples

Depending on display capability of LCD used, display will vary as shown below. xx contains the error number.

8-digit display	6-digit display	4-digit display
ERROR-xx	ERR-xx	E-xx

#### (2) Error Code List

Code	Class	Displayed error code	Description of the code and potential cause(s)
10	Electricity	Carriage Home NG SERVO LSI Communication Error	CRG can't be moved to inner diameter. CRG can't be moved from inner diameter. → Failure on home switch or CRG move mechanism. Communication error between microcomputer and SERVO LSI.
11	Electricity	Focus Servo NG	Focusing not available. → Stains on rear side of disc or excessive vibrations on REWRITABLE.
12	Electricity	Spindle Lock NG Subcode NG	Spindle not locked. Sub-code is strange (not readable). → Failure on spindle, stains or damages on disc, or excessive vibrations. A disc not containing CD-R data is found. Turned over disc are found, though rarely. CD signal error.
17	Electricity	Setup NG	AGC protection doesn't work. Focus can be easily lost. → Damages or stains on disc, or excessive vibrations on REWRITABLE.
30	Electricity	Search Time Out	Failed to reach target address. → CRG tracking error or damages on disc.
44	Electricity	ALL Skip	Skip setting for all track. (CD-R/RW)
50	Mechanism	CD On Mech Error	Mechanical error during CD ON. → Defective loading motor, mechanical lock and mechanical sensor.
A0	System	Power Supply NG	Power (VD) is ground faulted. → Failure on SW transistor or power supply (failure on connector).

Remarks: Mechanical errors are not displayed (because a CD is turned off in these errors).

Unreadable TOC does not constitute an error. An intended operation continues in this case.

Upper digits of an error code are subdivided as shown below:

1x: Setup relevant errors, 3x: Search relevant errors, Ax: Other errors.

## 6.4 SYSTEM MICROCOMPUTER TEST PROGRAM



### ● PCL output

In the normal operation mode (with the detachable panel installed, the ACC switched ON, the standby mode cancelled), shift the TESTIN (Pin 15) terminal to H. The clock signal is output from the PCL terminal (Pin 14). The frequency of the clock signal is 786.432kHz that is one 16th of the fundamental frequency. The clock signal should be  $786.432\text{kHz} \pm 31.5\text{Hz}$ . If the clock signal is out of the range, the X'tal (X601) should be replaced with new one.

# 7. GENERAL INFORMATION

## 7.1 DIAGNOSIS

### 7.1.1 DISASSEMBLY

#### ● Removing the Case (not shown)

1. Remove the Case.

#### ● Removing the CD Mechanism Module (Fig.1)

**1** Remove the four screws.

Disconnect the connector and then remove the CD Mechanism Module.

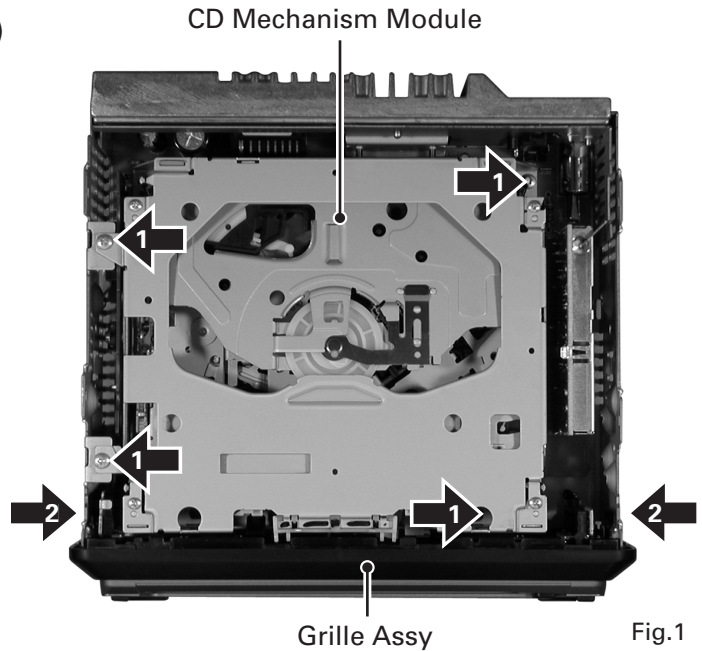

#### ● Removing the Grille Assy (Fig.1)

**2** Release the two latches and then remove the Grille Assy.

#### ● Removing the Tuner Amp Unit (Fig.2)

**1** Remove the screw.

**2** Remove the three screws.

**3** Straighten the tabs at three locations indicated.

**4** Remove the screw and then remove the Tuner Amp Unit.

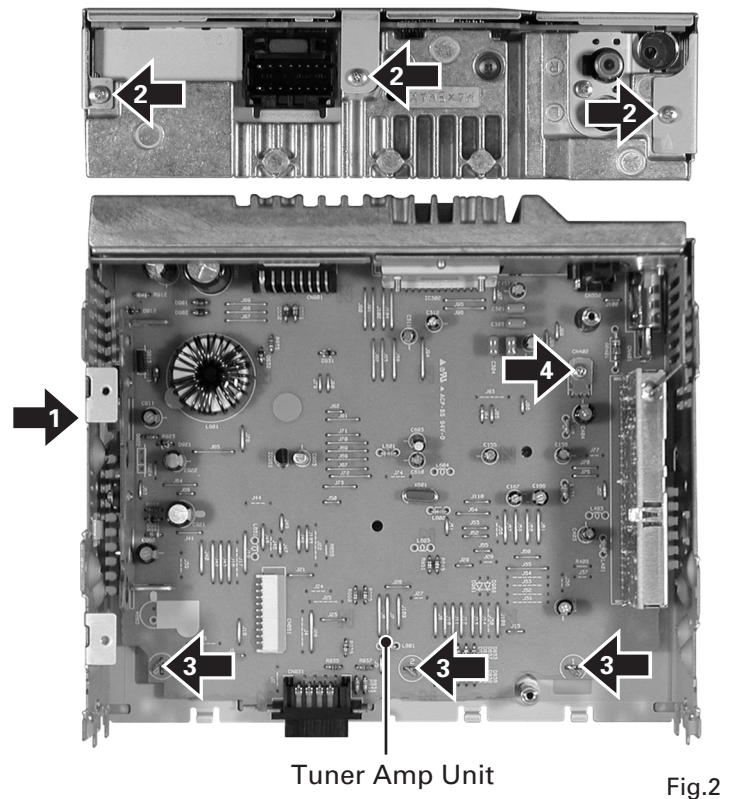

● **How to hold the Mechanism Unit**

- 1. Hold the top and bottom frame.
- 2. Do not squeeze top frame's front portion too tight, because it is fragile.

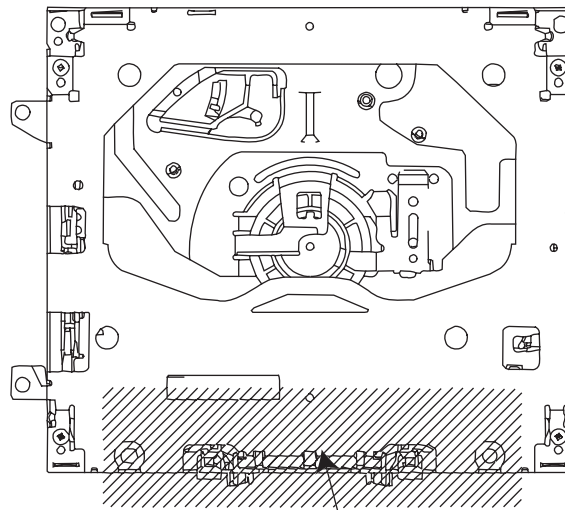

Do not squeeze.

● **Removing the Upper and Lower Frames**

- 1. With a disc clamped, remove the four springs (A), the two springs (B), the two springs (C), and the four screws.
  - 2. To remove the upper frame, open it on the fulcrum A.
  - 3. While lifting the carriage mechanism, remove the three dampers.
  - 4. With the frames removed, insert the connectors coming from the main unit and eject the disc.
- Caution: Before installing the carriage mechanism in the frames, be sure to apply some alcohol to the dampers and set the mechanism to the clamp mode.

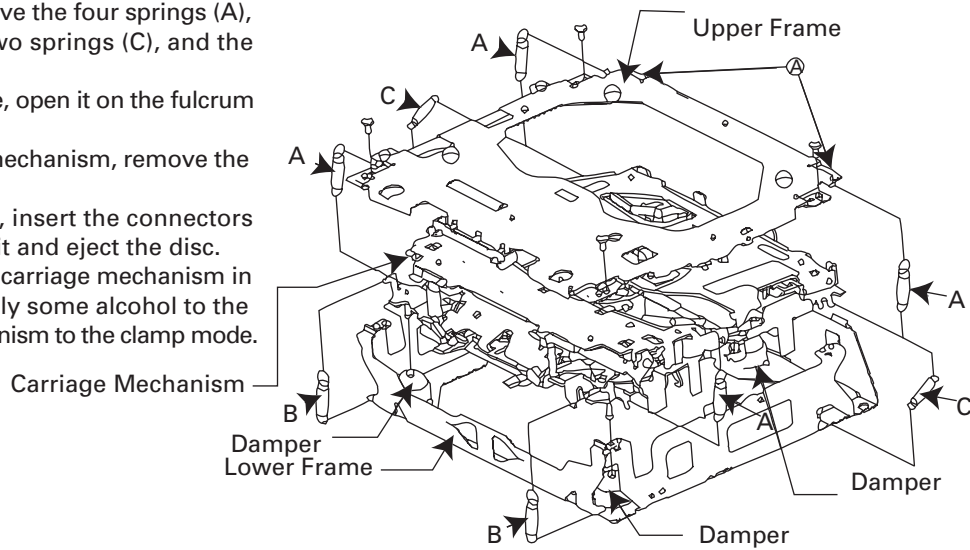



### ● Removing the Pickup Unit

1. Apply shorting solder to the Pickup flexible cable. Disconnect the cable.
2. Set the mechanism to the clamp mode.
3. Remove the lead wires from the inner holder.
4. Remove the washer, styling holder, change arm, and pickup lock arm.
5. While releasing from the hook of the inner holder, lift the end of the feed screw.

Caution: In assembling, move the planet gear to the load/eject position before setting the feed screw in the inner holder.

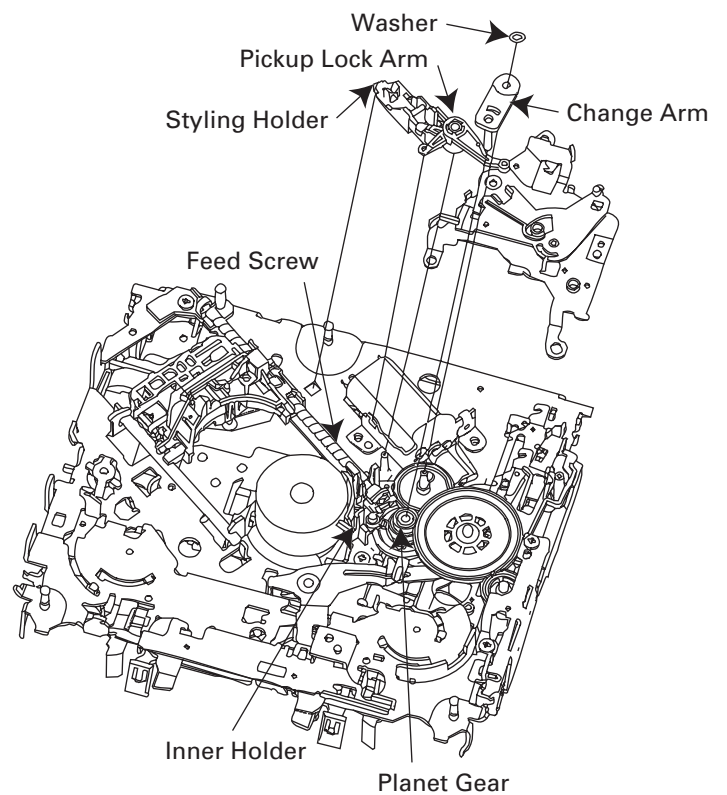
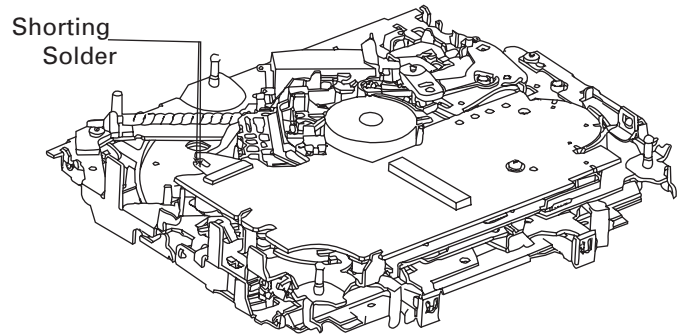

## 7.1.2 CONNECTOR FUNCTION DESCRIPTION

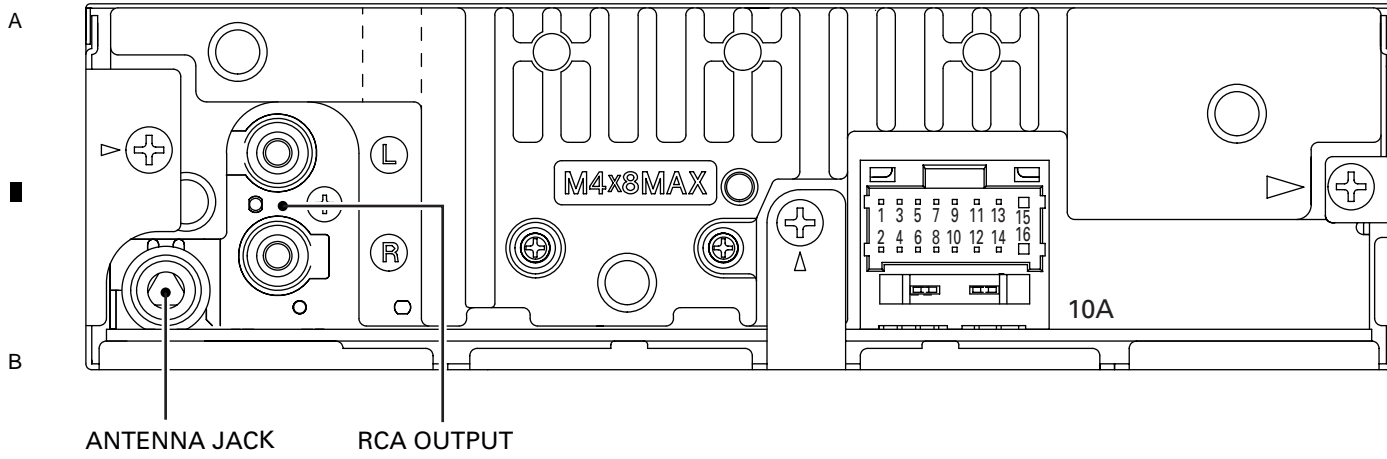

Pin No.		Pin No.	
1	FR+	9	-
2	RR+	10	-
3	FR-	11	B.REMOTE
4	RR-	12	-
5	FL+	13	-
6	RL+	14	ACC
7	FL-	15	GND
8	RL-	16	B.UP

## 7.2 PARTS

### 7.2.1 IC

#### ● Pin Functions(PE5449A)

Pin No.	Pin Name	I/O	Function and Operation
1	MODEL1		Model port 1
2,3	NC		Not used
4	AVSS		A/D GND
5,6	NC		Not used
7	AVREF1		A/D converter reference voltage
8	KYDT	I	Key data input
9	DPDT	O	Display data output
10	NC		Not used
11	TUNPDI	I	PLL IC data input
12	TUNPDO	O	PLL IC data output
13	TUNPCK	O	PLL IC clock output
14	PCL	O	Clock adjustment output
15	TESTIN	I	Test program mode input
16	XSI	I	Serial data input
17	XSO	O	Serial data output
18	XSCK	O	Serial data clock output
19,20	NC		Not used
21	SWVDD	O	Keyboard unit power supply control output
22	ILMPW	O	Illumination power supply control output
23	NC		Not used
24	XRST	O	CD LSI reset output
25	XA0	O	CD LSI identification control signal output
26	XSTB	O	CD LSI strobe output
27	CLAMSW		Not used
28	CONT	O	Servo driver power supply control output
29	LOEJ	O	CD load motor LOAD/EJECT direction exchange output
30	CLCONT	O	Driver input select output
31	NC		Not used
32	DALMON	O	Stand-by output
33	VSS1		GND
34	BRST		Not used
35	BRXEN		Not used
36	BRSQ		Not used
37	ROMDATA	O	ROM collection data output (Not used)
38	ROMCLK	O	ROM collection clock output (Not used)
39	ROMCS	O	ROM collection chip select output (Not used)
40	RECIEVE		During RDS data reception
41	VDCONT	O	VD control output
42	NC		Not used
43	SYSPW	O	System power supply control output
44,45	NC		Not used
46	KEY2		Not used
47	NC		Not used
48	MUTE	O	System mute output
49	ANTPW	O	B. REMOTE output
50	NC		Not used
51	VST	O	Strobe pulse output for electronic volume
52	VDT	O	Data output for electronic volume
53	VCK	O	Clock output for electronic volume
54	NC		Not used
55	TUNPCE2	O	EEPROM chip enable output 2
56	TUNPCE1	O	EEPROM chip enable output 1
57	RDT	I	RDS demodulation data input (Not used)
58	RDSLK	I	RDS LK signal input (Not used)
59	RDS57K	I	RDS 57kHz pulse count input (Not used)
60	RESET	I	Reset input
61	LDET	I	PLL lock sense input

Pin No.	Pin Name	I/O	Function and Operation
62	RCK	I	RDS demodulation clock input (Not used)
63	ASENS	I	ACC sense input
64	BSENS	I	Back up sense input
65	DSSENS	I	Grille detach sense input
66	INTRQ	I	SOURCE key sense input
67	VSS0		GND
68	VDD1		Power supply
69	X2		Crystal oscillator connection pin
70	X1		Crystal oscillator connection pin
71	IC(VPP)		Connect to GND
72	NC		Not used
73	XT1		Connect to GND
74	VDD0		Power supply
75	AVDD		Positive power supply terminal for analog circuit
76	SL	I	SD level input from tuner
77	TEMP		Connect to VDD
78	VDSSENS	I	VD power supply voltage sense input
79	DISCSSENS	I	CD DISC sense input
80	STRKEY1		NC

\* PE5449A

IC's marked by \* are MOS type.

Be careful in handling them because they are very liable to be damaged by electrostatic induction.

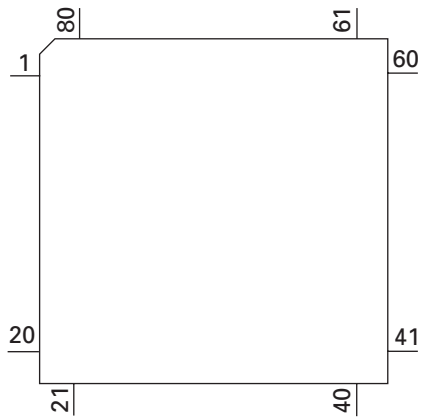

BA33BC0FP

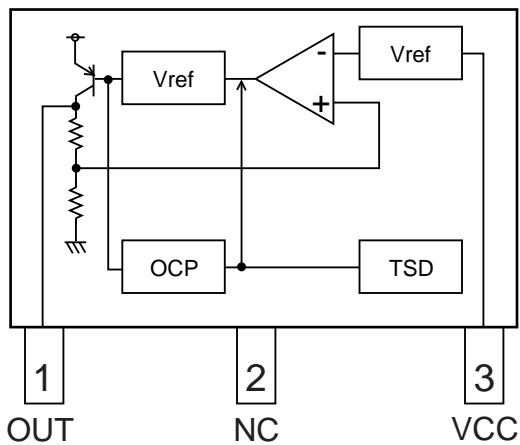

### ● Pin Functions(PD6340A)

Pin No.	Pin Name	I/O	Function and Operation
1-5	SEG4-0	O	LCD segment output
6-9	COM3-0	O	LCD common output
10	VLCD		LCD drive power supply
11-14	KST3-0	O	Key strobe output
15,16	KDT0,1	I	Key data input (analogue input)
17	REW	I	Remote control reception input
18	DPDT	I	Display data input
19	NC		Not used
20	KYDT	O	Key data output
21	MODA		GND
22	X0		Crystal oscillator connection pin
23	X1		Crystal oscillator connection pin
24	VSS		GND
25,26	KDT2,3	I	Key data input
27	NC		Not used
28	KST4	O	Key strobe output
29-32	NC		Not used
33-55	SEG35-13	O	LCD segment output
56	VDD		Power supply
57-64	SEG12-5	O	LCD segment output

\* PD6340A

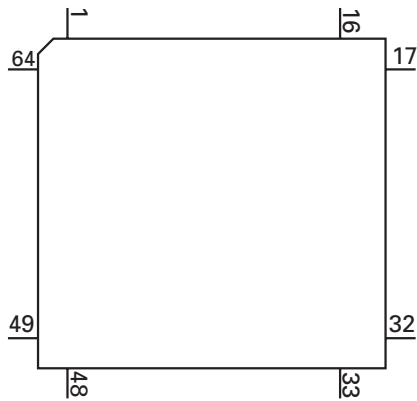

### ● Pin Functions(UPD63712AGC)

Pin No.	Pin Name	I/O	Function and Operation
1	LD	O	Output of LD
2	PD	I	Input of PD
3	PN	I	Assignment of pickup polarity
4	AVDD		Power supply for the analog system
5	DGND		Ground for digital circuits
6	RFOK	O	Output of RFOK
7	INTQ	O	Interruption signals to the external microcomputer
8	RST	I	Input of reset
9	A0	I	Command/Parameter discrimination signal input
10	STB	I	Data strobe signal input
11	SCK	I	Serial data clock input
12	SO	O	Serial data output
13	SI	I	Serial data input
14	DVDD		Power supply for digital circuits
15	DAVDD		Power supply for DAC
16	ROUT	O	Output of audio for the right channel
17	DAGND		GND for DAC
18	REGC		Connected to the capacitor for band gap
19	DAGND		GND for DAC
20	LOUT	O	Output of audio for the left channel
21	DAVDD		Power supply for DAC
22	XVDD		Power supply for the crystal oscillator
23	XTAL	O	Connected to the crystal oscillator
24	XTAL	I	Connected to the crystal oscillator
25	XGND		Ground for the crystal oscillator
26	DVDD		Power supply for digital circuits
27	C1D1	O	Information on error correction
28	C1D2	O	Information on error correction
29	C2D1	O	Information on error correction
30	C2D2	O	Information on error correction
31	C2D3	O	Information on error correction
32	LOCK	O	Output of LOCK
33	MIRR	O	MIRR signal
34	HOLD	O	HOLD signal
35	PLCK	O	Output of PLCK
36	C16M	O	Output of 16.9344MHz
37	DGND		Ground for digital circuits
38	TX	O	DAI output
39	EMPH	O	Pre-emphasis information output
40	FLAG	O	The flag for which output sound data cannot be corrected is outputted
41	DVDD		Power supply for digital circuits
42	LIMIT	I	Signal is inputted when the register can be read
43	XTALEN	I	Permission to oscillate
44	DGND		Ground for digital circuits
45	DIN	I	Input of audio data
46	DOUT	O	Output of audio data
47	SCKIN	I	Clock input for audio data
48	SCKO	O	Clock output for audio data
49	LRCKIN	I	Input of LRCK for audio data
50	LRCK	O	Output LRCK for audio data
51	DVDD		Power supply for digital circuits
52	FD+	O	Output of focus drive PWM
53	FD-	O	Output of focus drive PWM
54	TD+	O	Output of tracking drive PWM
55	TD-	O	Output of tracking drive PWM
56	SD+	O	Output of thread drive PWM
57	SD-	O	Output of thread drive PWM
58	MD+	O	Output of spindle drive PWM
59	MD-	O	Output of spindle drive PWM
60	DGND		Ground for digital circuits

Pin No.	Pin Name	I/O	Function and Operation
61	TESTEN	I	Connected to GND
62-66	TEST4-0	I	Connected to GND
67	ADGND		GND for DAC
68	EFM	O	Output of EFM signals
69	ASY	I	Input of asymmetry
70	ADVDD		Power supply for DAC
71	RFI	I	Input of RF
72, 73	EQ2, 1		Equalizer 2, 1
74	RF-	I	Reversal input of RF
75	RF2-	I	Reversal input of RF2
76	AGCO	O	Output of RF
77	AGCI	I	Input of AGC
78	RFO	O	Output of RF
79	ATEST	O	Analog tests
80	C3T		Connection to the capacitor for detecting 3T
81	AGND		Ground for the analog system
82	A	I	Input of A
83	C	I	Input of C
84	B	I	Input of B
85	D	I	Input of D
86	F	I	Input of F
87	E	I	Input of E
88	VREFIN	I	Photo-detector input bias voltage
89	AVDD		Power supply for the analog system
90	REFOUT	O	Output of reference voltage
91	REFC		Connected to the capacitor for output of REFOUT
92	FE-	I	Reversal input of FE
93	FEO	O	Output of FE
94	ADCIN	I	TEST
95	TE-	I	Reversal input of TE
96	TEO	O	Output of TE
97	TE2	O	TE2
98	TEC	I	TEC
99	AGND		Ground for the analog system
100	PWMSW	I	Servo PWM mode switching

\* UPD63712AGC

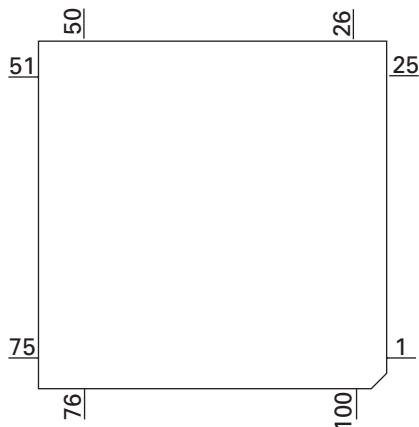

### ● Pin Functions(BA5835FP)

Pin No.	Pin Name	Function and Operation
1	VR	Input pin for reference voltage
2	OPIN2(+)	Input pin for non-inverting input for CH2 preamplifier
3	OPIN2(-)	Input pin for inverting input for CH2 preamplifier
4	OPOUT2	Output pin for CH2 preamplifier
5	OPIN1(+)	Input pin for non-inverting input for CH1 preamplifier
6	OPIN1(-)	Input pin for inverting input from CH1 preamplifier
7	OPOUT1	Output pin for CH1 preamplifier
8	GND	Ground pin
9	MUTE	Mute control pin
10	POWVCC1	Power supply pin for CH1, CH2, and CH3 at "Power" stage
11	VO1(-)	Driver CH1 - Negative output
12	VO1(+)	Driver CH2 - Positive output
13	VO2(-)	Driver CH2 - Negative output
14	VO2(+)	Driver CH2 - Positive output
15	VO3(+)	Driver CH2 - Positive output
16	VO3(-)	Driver CH2 - Negative output
17	VO4(+)	Driver CH4 - Positive output
18	VO4(-)	Driver CH4 - Negative output
19	POWVCC2	Power supply pin for CH4 at "Power" stage
20	GND	Ground pin
21	CNT	Control pin
22	LDIN	Loading input
23	OPOUTSL	Output pin for preamplifier for thread
24	OPINLSL	Input pin for preamplifier for thread
25	OPOUT3	CH3 preamplifier output pin
26	OPIN3(-)	Input pin for inverting input for CH3 preamplifier
27	OPIN3(+)	Input pin for non-inverting input for CH3 preamplifier
28	PREVCC	PreVcc

BA5835FP

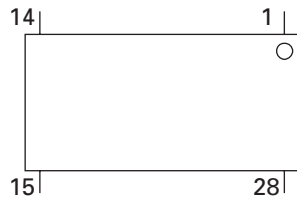

NJM2885DL1-33

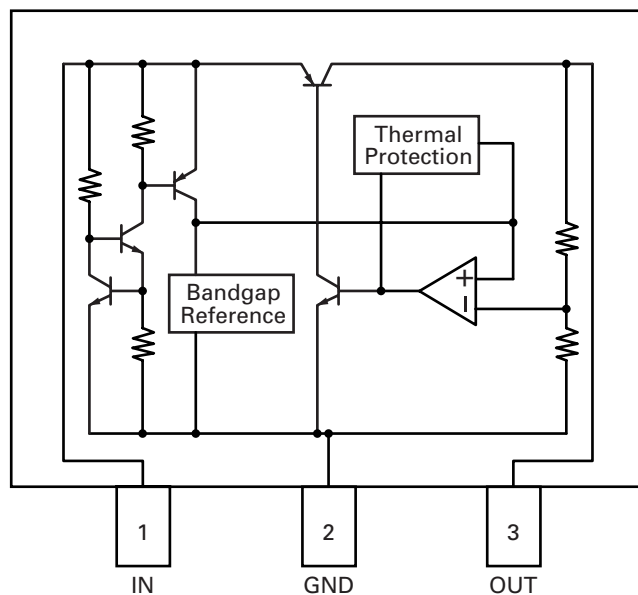



## ● FM/AM Tuner Unit

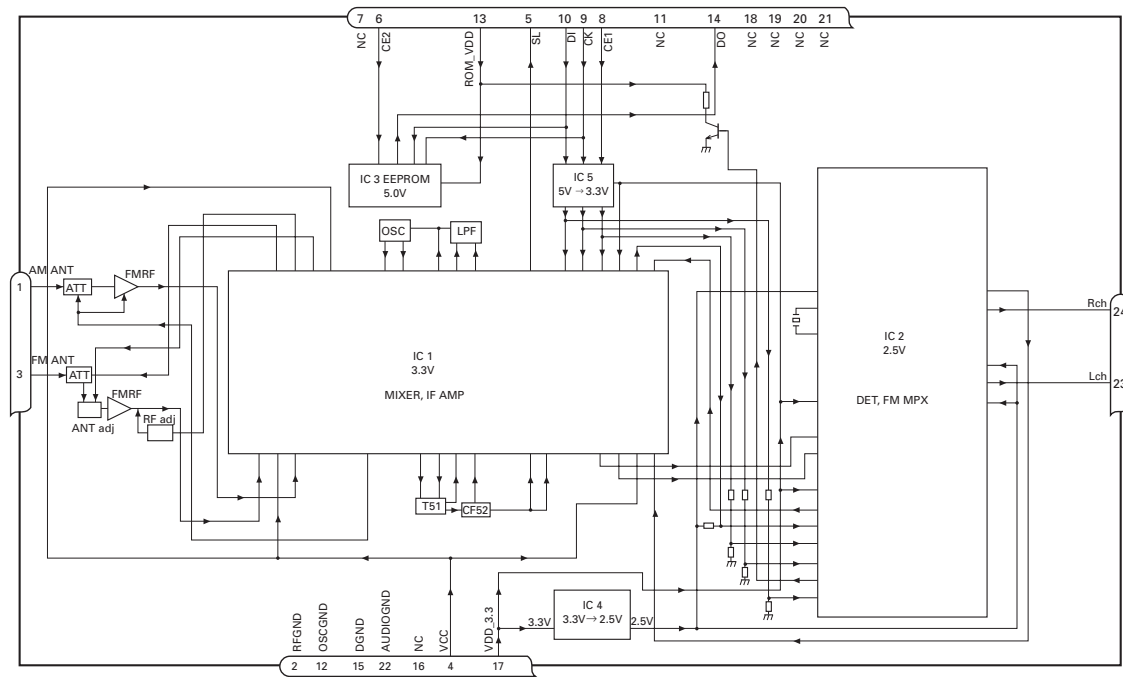

No.	Symbol	I/O	Explain
1	AMANT	I	AM antenna input AM antenna input high impedance AMANT pin is connected with an all antenna by way of 4.7μH. (LAU type inductor) A series circuit including an inductor and a resistor is connected with RF ground for the countermeasure against the hum of power transmission line.
2	RFGND		RF ground Ground of antenna block
3	FMANT	I	FM antenna input Input of FM antenna 75Ω Surge absorber(DSP-201M-S00B) is necessary.
4	VCC		power supply The power supply for analog block. D.C 8.4V ± 0.3V
5	SL	O	signal level Output of FM/AM signals level
6	CE2	I	chip enable-2 Chip enable for EEPROM "Low" active
7	NC		non connection Not used
8	CE1	I	chip enable-1 Chip enable for AF•RF "High" active
9	CK	I	clock Clock
10	DI	I	data in Data input
11	NC		non connection Not used
12	OSCGND		osc ground Ground of oscillator block
13	ROM_VDD		power supply Power supply for EEPROM pin 13 is connected with a power supply of micro computer.
14	DO	O	data out Data output
15	DGND		digital ground Ground of digital block
16	NC		non connection Not used
17	VDD_3.3		power supply The power supply for digital block. 3.3V ± 0.2V
18	NC		non connection Not used
19	NC		non connection Not used
20	NC		non connection Not used
21	NC		non connection Not used
22	AUDIOGND		audio ground Ground of audio block
23	L ch	O	L channel output FM stereo "L-ch" signal output or AM audio output
24	R ch	O	R channel output FM stereo "R-ch" signal output or AM audio output

# 7.2.2 DISPLAY

● LCD(CAW1848)

A  
B  
C  
D  
E  
F

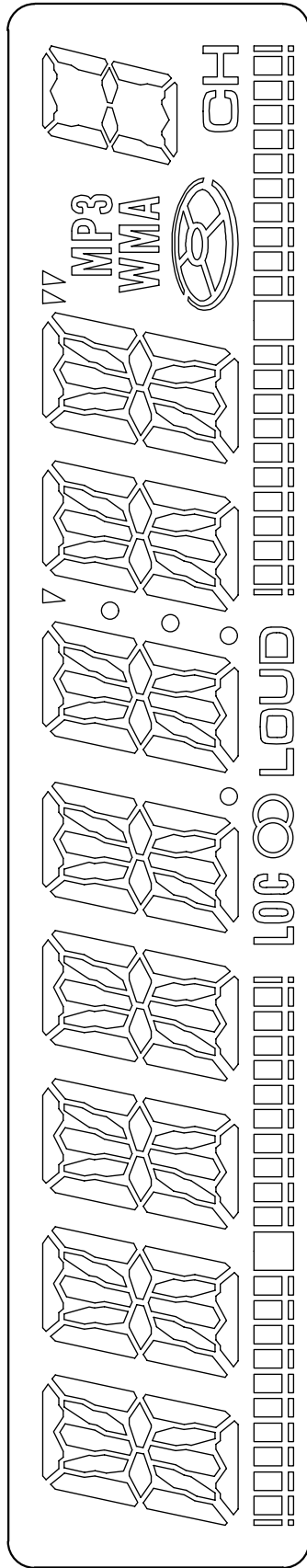

# 7.3 OPERATIONAL FLOW CHART

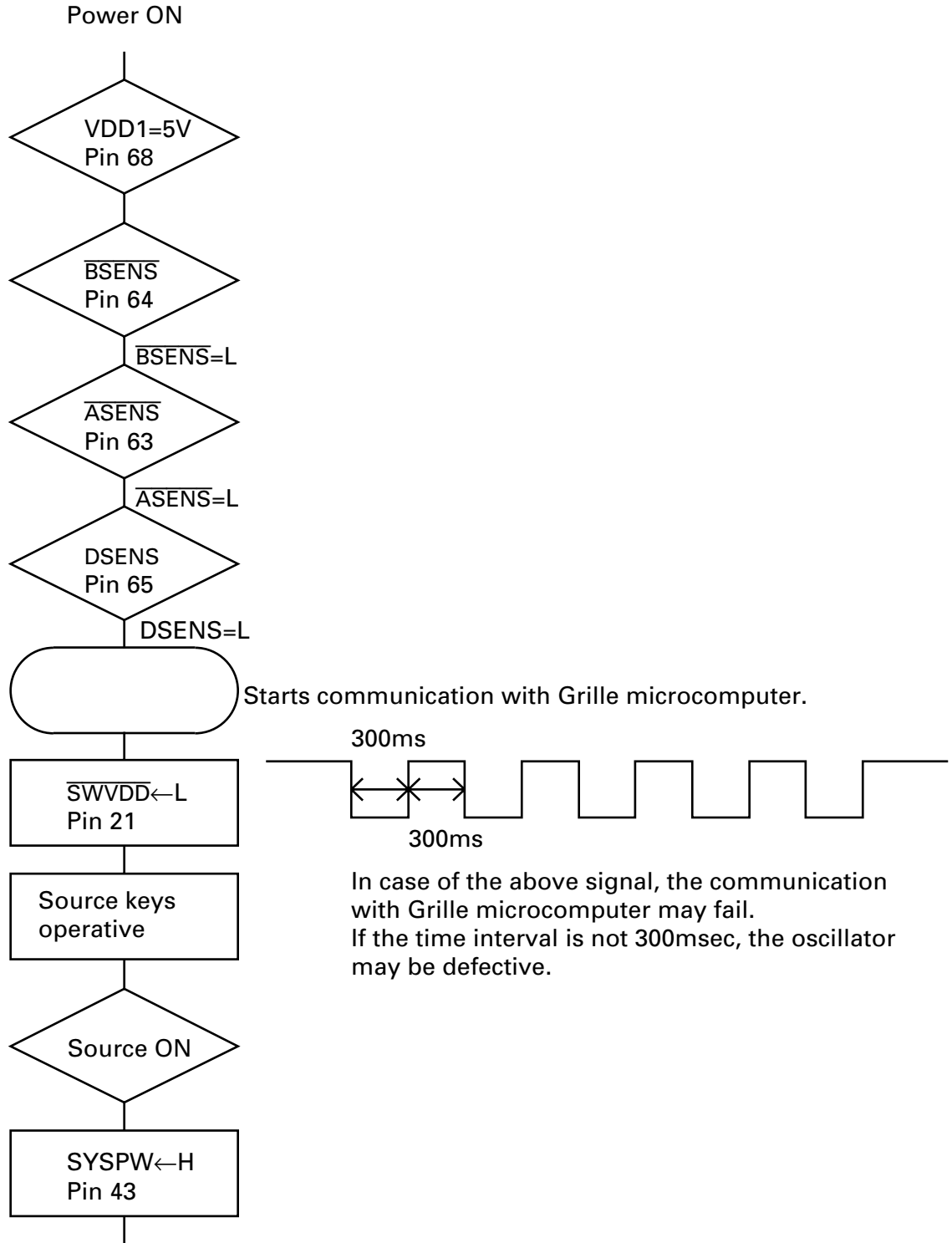

Completes power-on operation.(After that, proceed to each source operation.)

# 7.4 CLEANING



A

Before shipping out the product, be sure to clean the following portions by using the prescribed cleaning tools:

Portions to be cleaned	Cleaning tools
CD pickup lenses	Cleaning liquid : GEM1004 Cleaning paper : GED-008

B

C

D

E

F

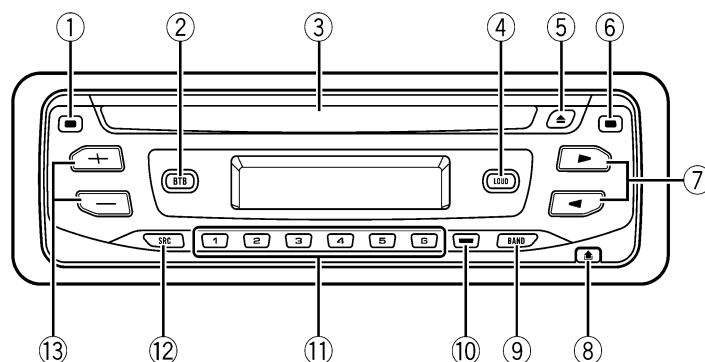

## Head unit

### ① CLOCK button

Press to change to the clock display.

### ② BTB button

Press to select various BTB (bass treble booster) setting.

### ③ Disc loading slot

Insert a disc to play.

### ④ LOUDNESS button

Press to turn loudness on or off.

### ⑤ EJECT button

Press to eject a CD from your built-in CD player.

### ⑥ AUDIO button

Press to select various sound quality controls.

### ⑦ ◀/▶ buttons

Press to do manual seek tuning, fast forward, reverse and track search controls. Also used for controlling functions.

### ⑧ DETACH button

Press to remove the front panel from the head unit.

### ⑨ BAND button

Press to select among three FM bands and one AM band and to cancel the control mode of functions.

### ⑩ LOCAL/BSM button

Press to turn local function on or off. Press and hold to turn BSM function on or off.

### ⑪ 1-6 buttons

Press for preset tuning.

### ⑫ SOURCE button

This unit is turned on by selecting a source. Press to cycle through all the available sources.

### ⑬ VOLUME (+/-) buttons

Press to increase or decrease the volume. 

## Playing a CD

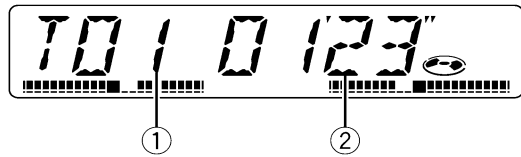

### ① Track number indicator

Shows the track currently playing.

### ② Play time indicator

Shows the elapsed playing time of the current track.

### 1 Insert a CD into the CD loading slot.

Playback will automatically start.

- **Be sure to turn up the label side of a disc.**
- After a CD has been inserted, press **SOURCE** to select the built-in CD player.
- You can eject a CD by pressing **EJECT**.

### 2 Use **VOLUME** to adjust the sound level.

### 3 To perform fast forward or reverse, press and hold ◀ or ▶.

### 4 To skip back or forward to another track, press ◀ or ▶.

Pressing ▶ skips to the start of the next track. Pressing ◀ once skips to the start of the current track. Pressing again will skip to the previous track.



### Notes

- The built-in CD player plays one, standard, 12-cm or 8-cm (single) CD at a time. Do not use an adapter when playing 8-cm CDs.
- Do not insert anything other than a CD into the CD loading slot.
- If an error message such as **ERROR-11** is displayed. ▣

## Playing tracks in a random order

Random play lets you play back tracks on the CD in a random order.

- **Press 4 repeatedly to turn random play on or off.**

When random play is on, **RDM** appears in the display. ▣

## Repeating play

Repeat play lets you hear the same track over again.

- **Press 5 repeatedly to turn repeat play on or off.**

When repeat play is on, **RPT** appears in the display.

- If you perform track search or fast forward/reverse, repeat play is automatically cancelled. ▣

## Pausing CD playback

Pause lets you temporarily stop playback of the CD.

- **Press 6 repeatedly to turn pause on or off.**

When pause is on, **PAUSE** appears in the display. ▣

● CONNECTION DIAGRAM

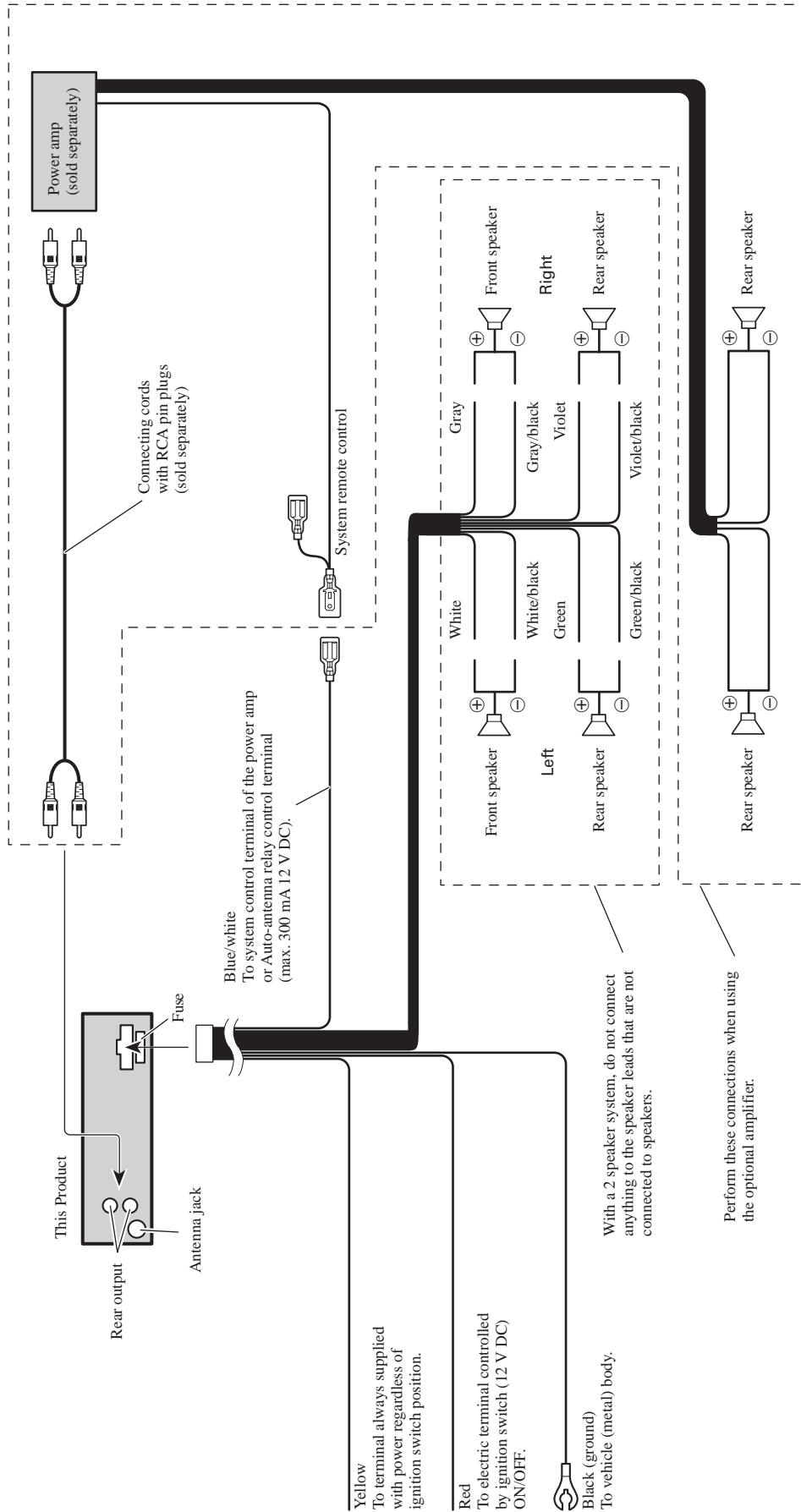

A B C D E F

● Jigs List

Name	Jig No.	Remarks
Test Disc	TCD-782	Checking the grating
L.P.F.		Checking the grating (Two pieces)

A

B

C

D

E

F