

CHAPTER 7. CHASSIS LAYOUT

[1] CHASSIS LAYOUT

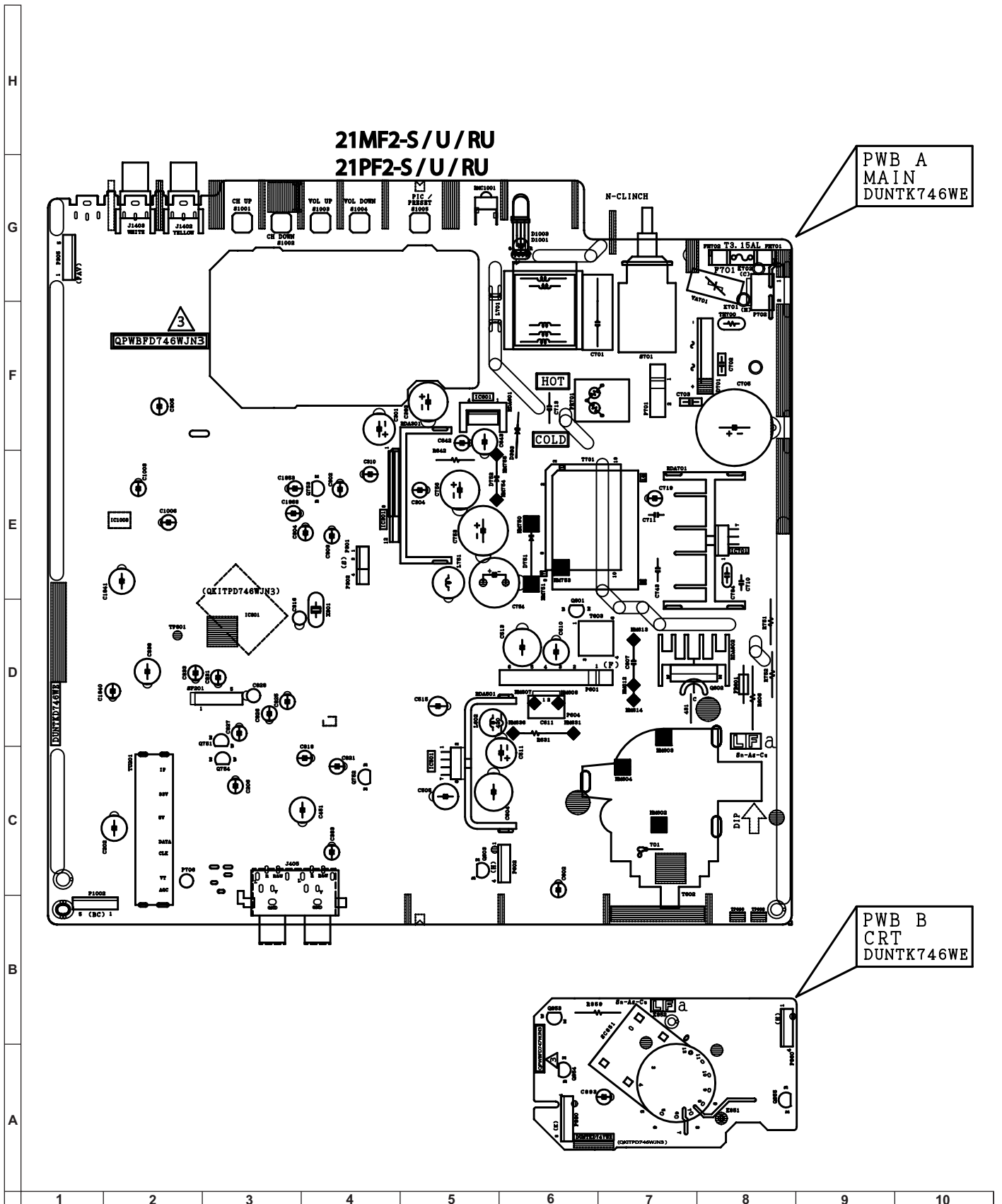

CHAPTER 8. BLOCK DIAGRAM

[1] BLOCK DIAGRAM: MAIN UNIT

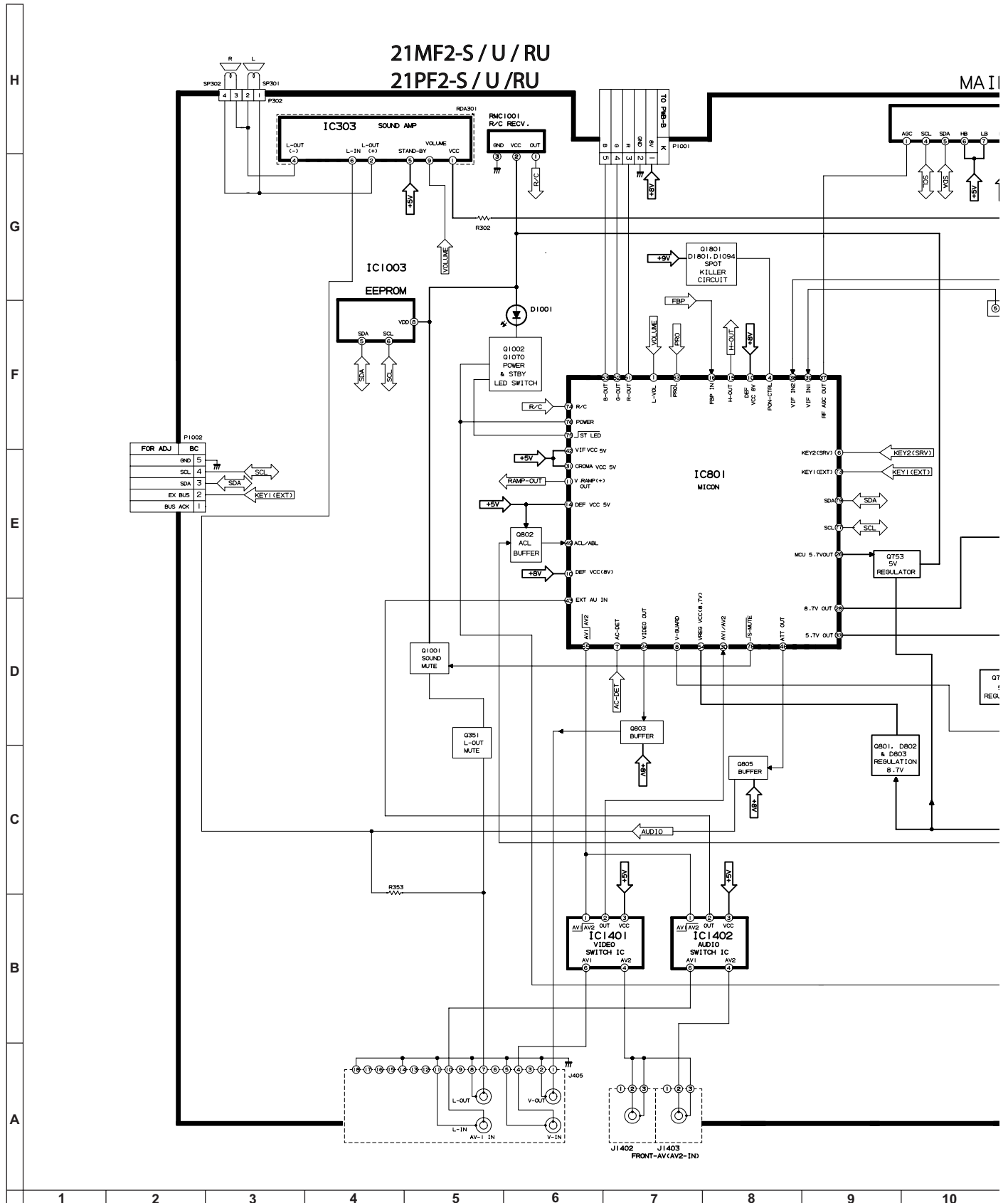

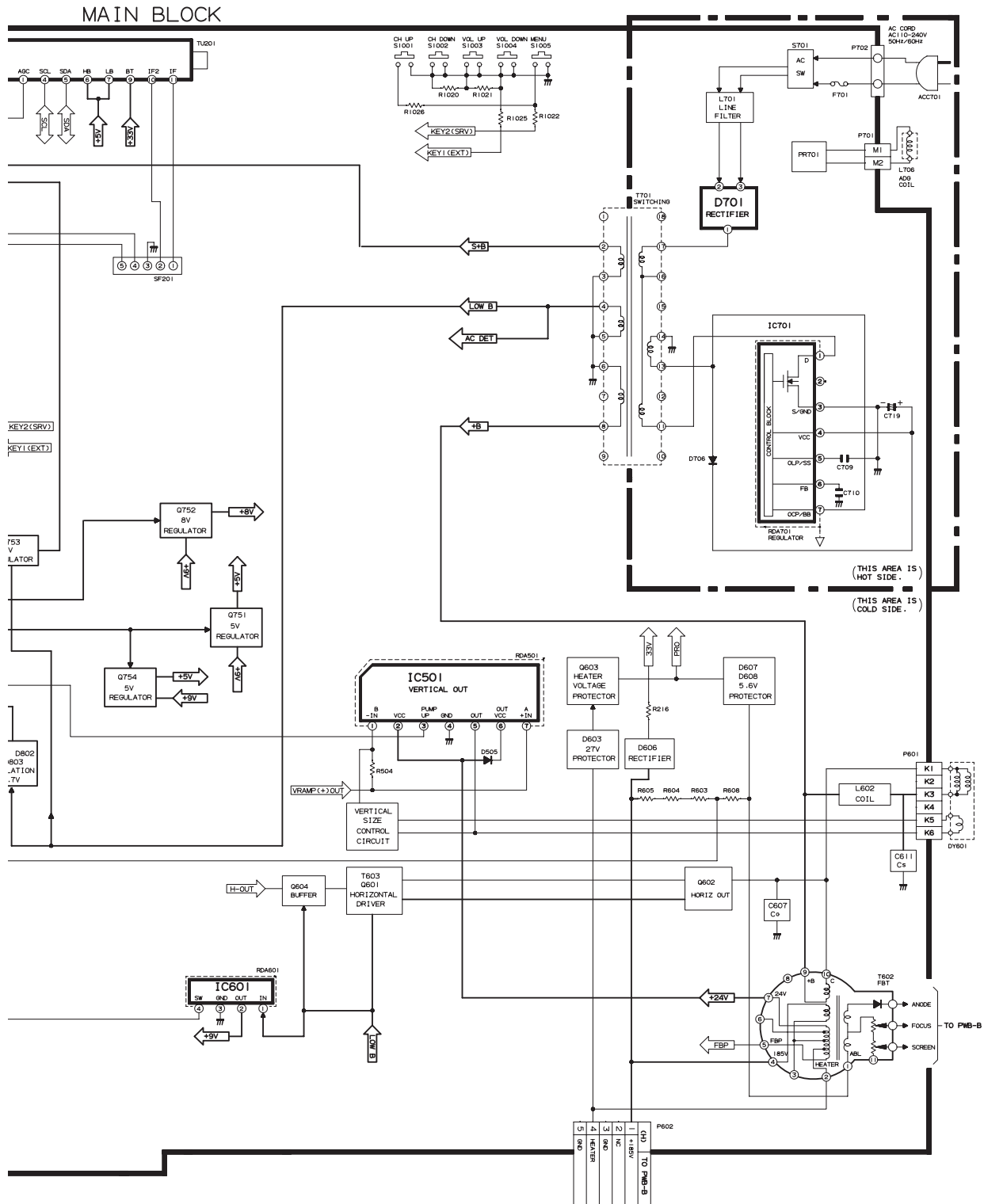

10	11	12	13	14	15	16	17	18	19
----	----	----	----	----	----	----	----	----	----

[2] BLOCK DIAGRAM: CRT UNIT

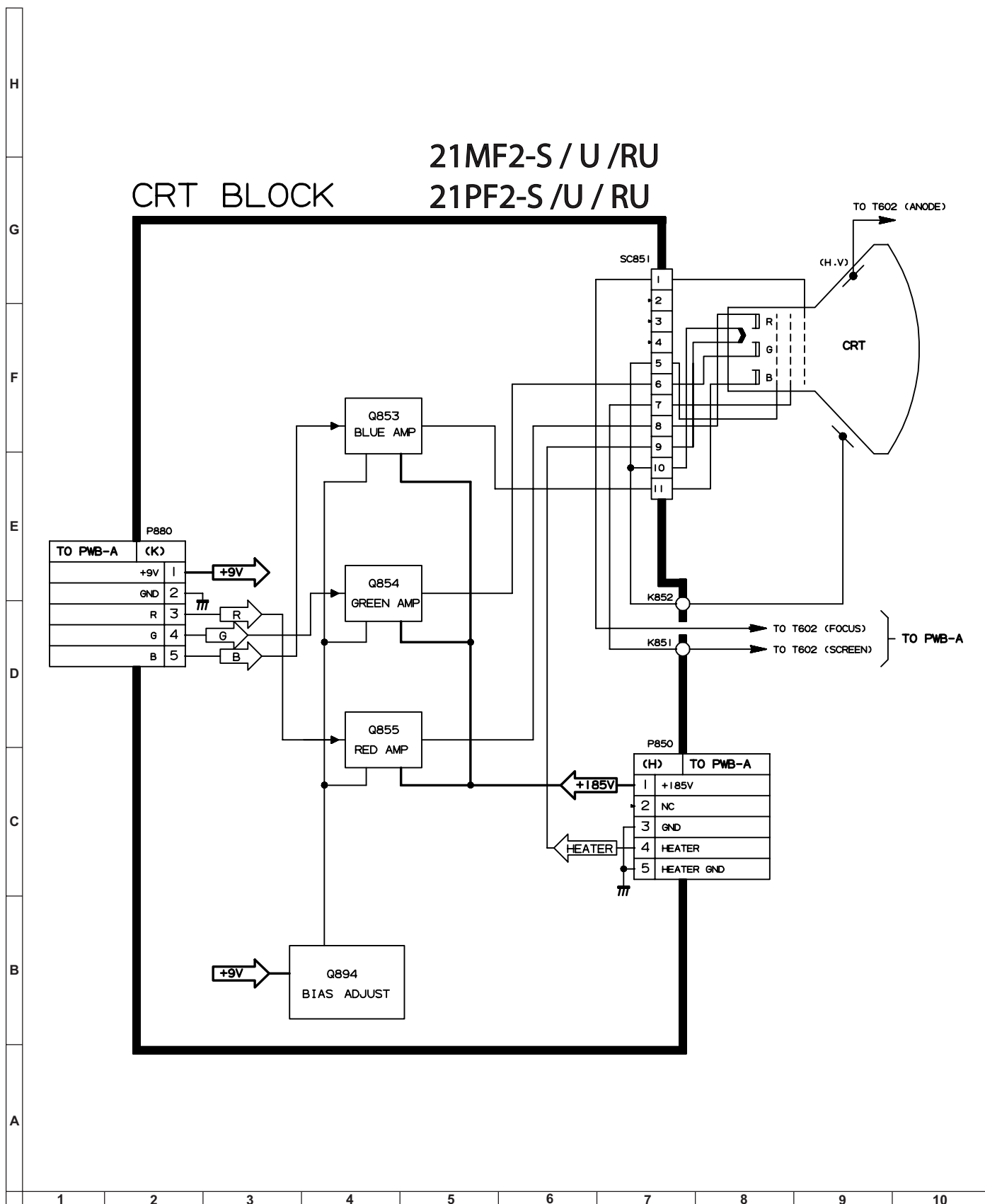



CHAPTER 9. DESCRIPTION ON SCHEMATIC DIAGRAM

[1] DESCRIPTION OF SCHEMATIC DIAGRAM

SAFETY NOTES:

1. DISCONNECT THE AC PLUG FROM THE AC OUTLET BEFORE REPLACING PARTS.
2. SEMICONDUCTOR HEAT SINKS SHOULD BE REGARDED AS POTENTIAL SHOCK HAZARDS WHEN THE CHASSIS IS OPERATING.

IMPORTANT SAFETY NOTICE:

PARTS MARKED WITH "  " () ARE IMPORTANT FOR MAINTAINING THE SAFETY OF THE SET. BE SURE TO REPLACE THESE PARTS WITH SPECIFIED ONES FOR MAINTAINING THE SAFETY AND PERFORMANCE OF THE SET.

SERVICE PRECAUTION:

THE AREA ENCLOSED BY THIS LINE (— - —) IS DIRECTLY CONNECTED WITH AC MAINS VOLTAGE. WHEN SERVICING THE AREA, CONNECT AN ISOLATING TRANSFORMER BETWEEN TV RECEIVER AND AC LINE TO ELIMINATE HAZARD OF ELECTRIC SHOCK.

CAUTION:

This circuit diagram is a standard one, printed circuits may be subject to change for product improvement without prior notice.

NOTES:

1. The unit of resistance "ohm" is omitted. (K = 1000 ohms, M = Mega ohm).
2. All resistors are 1/16 watt, unless otherwise noted.
3. All capacitors are μF , unless otherwise noted. (P = $\mu\mu\text{F}$).

VOLTAGE MEASUREMENT CONDITIONS:

1. Voltages in parenthesis measured with no signal.
2. Voltages without parenthesis measured with 3mV B & W or Colour signal.
3. All the voltages in each point are measured with VTVM.

WAVEFORM MEASUREMENT CONDITIONS:

1. The colour bar generator signal of 1.0V peak applied at pin (32) of IC801.
2. Approximately 4V AGC bias.

CHAPTER 10. WAVEFORM

[1] WAVEFORMS

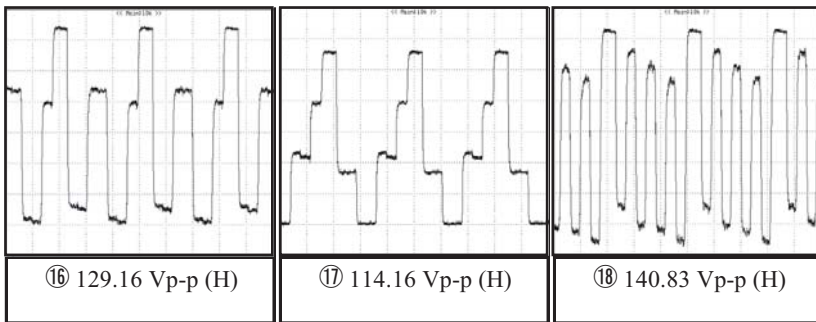
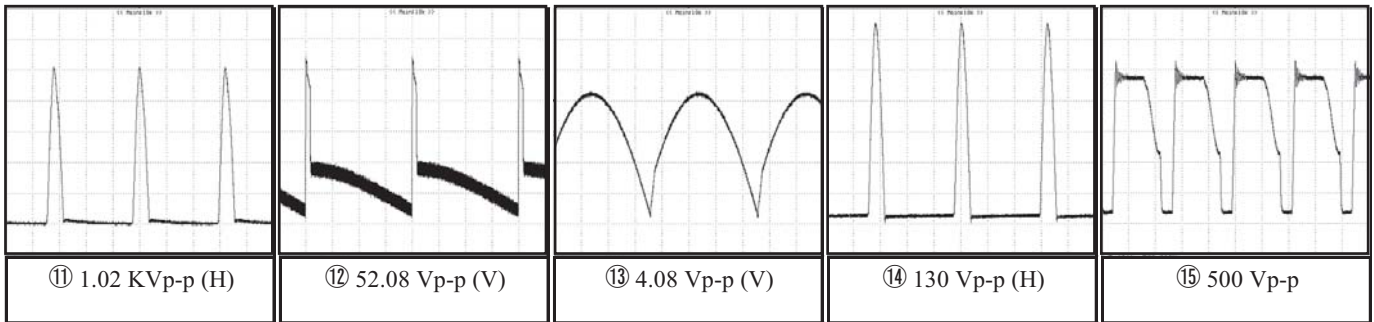
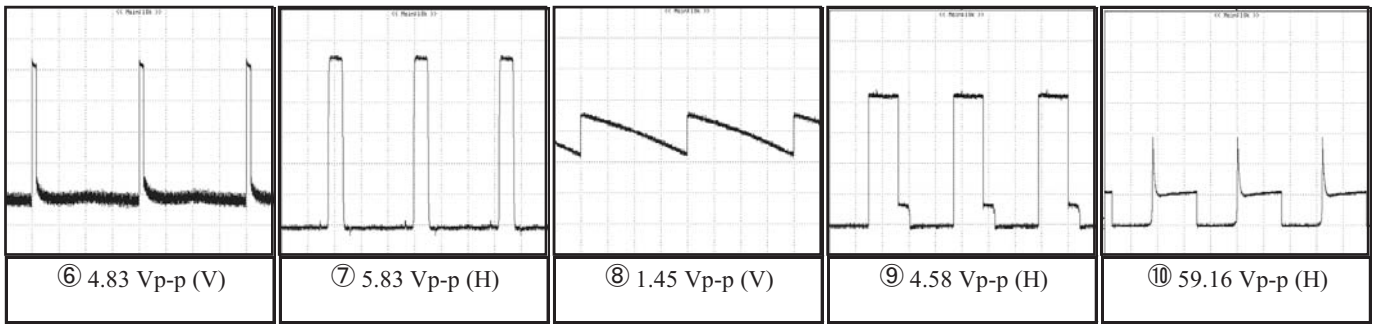
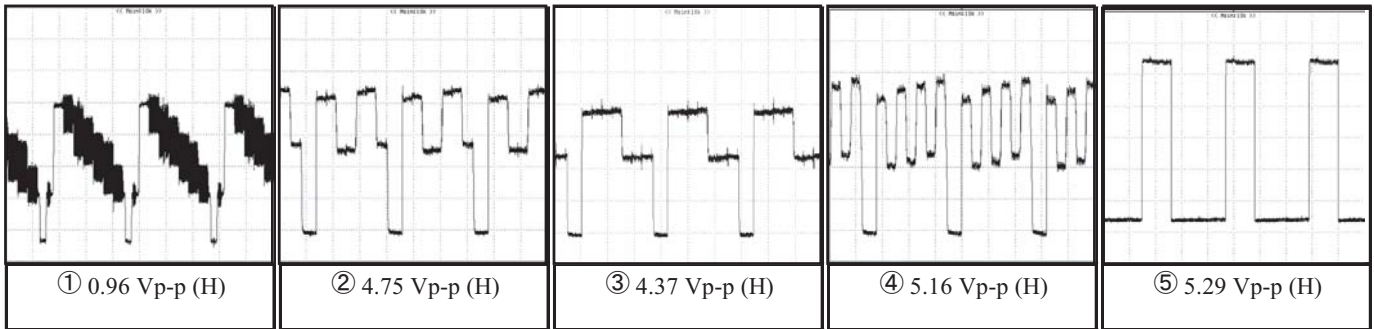

CHAPTER 11. SCHEMATIC DIAGRAM

[1] SCHEMATIC DIAGRAM: CRT UNIT (21MF2-S / U , 21PF2-S / U)

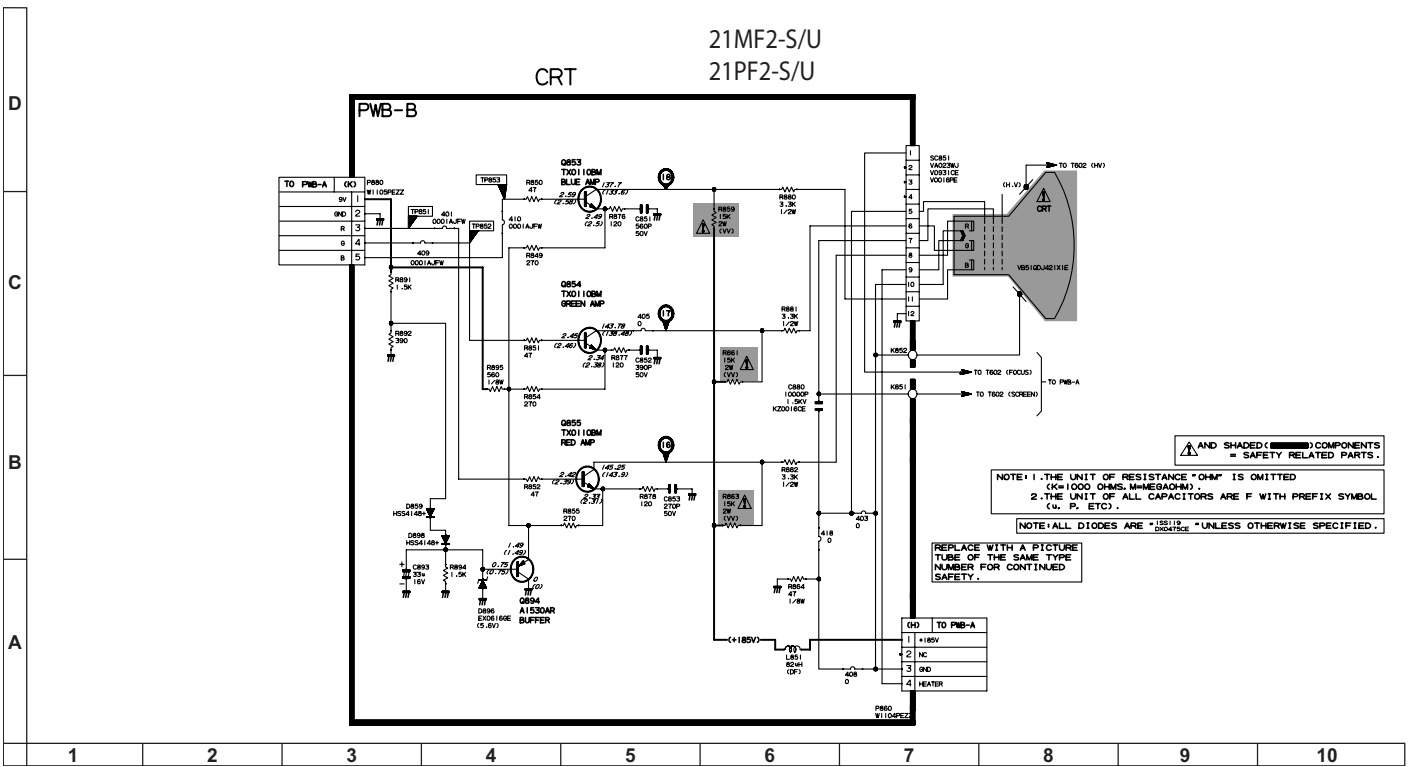

[2] SCHEMATIC DIAGRAM: CRT UNIT (21MF2-RU , 21PF2-RU)

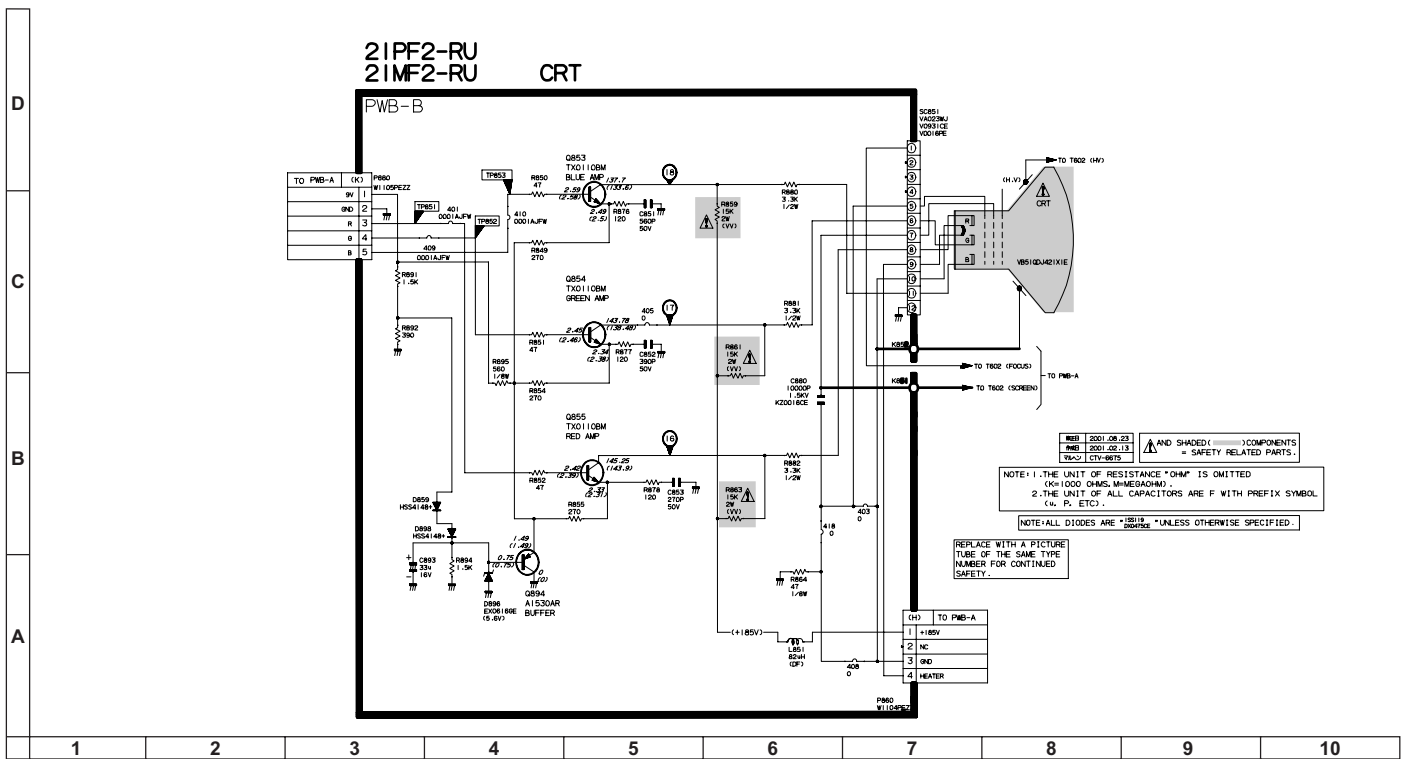

[3] SCHEMATIC DIAGRAM: MAIN UNIT

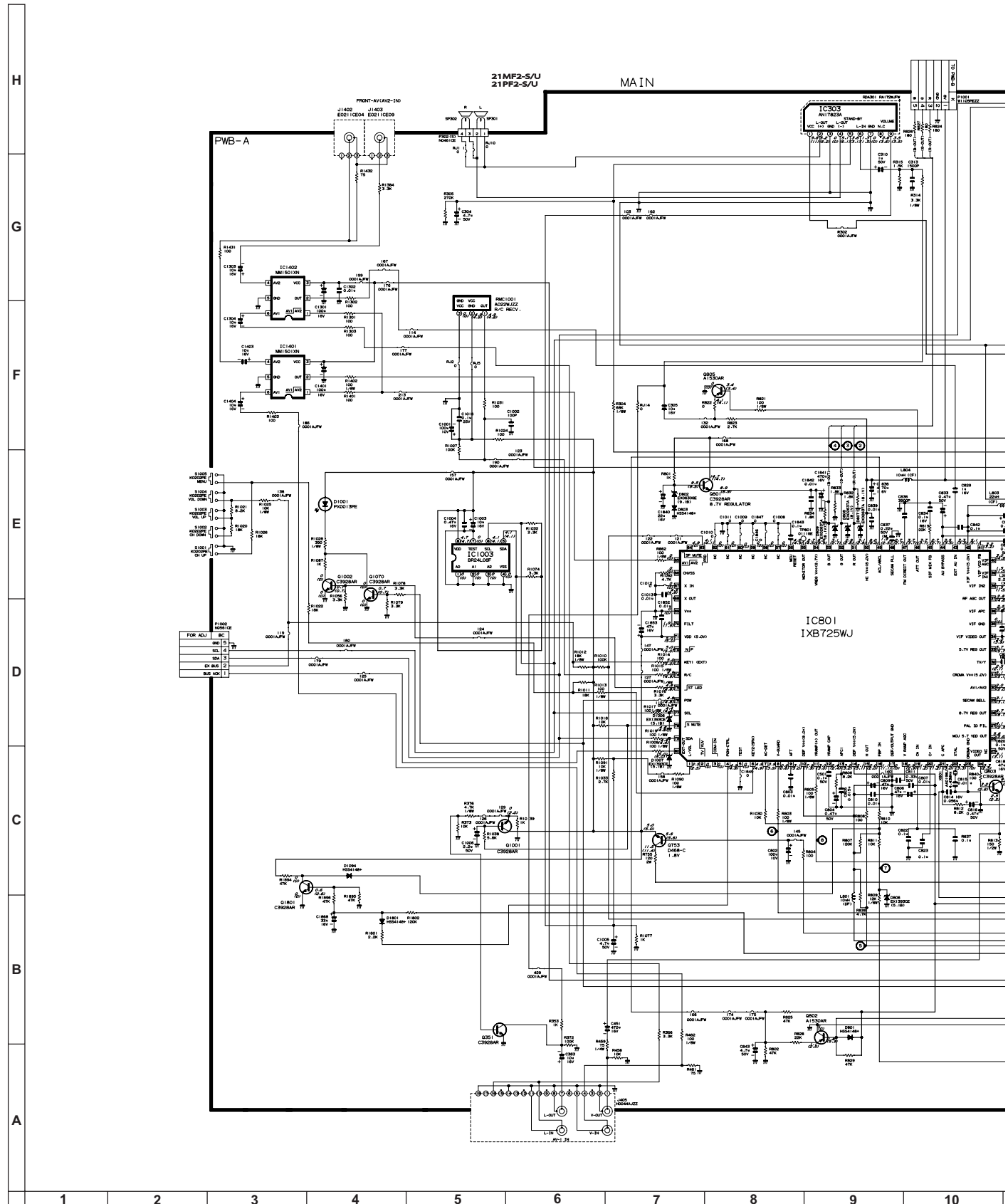

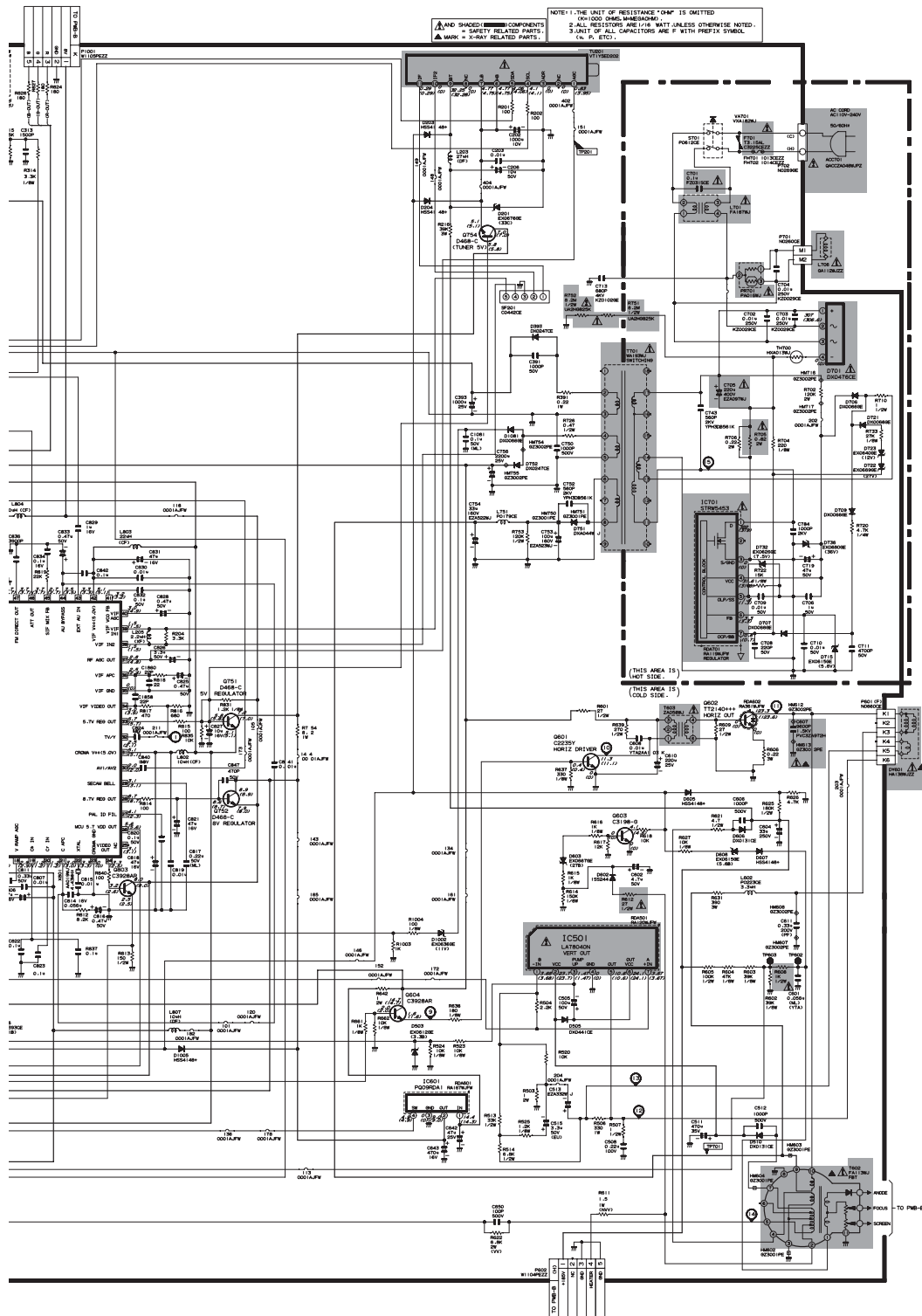

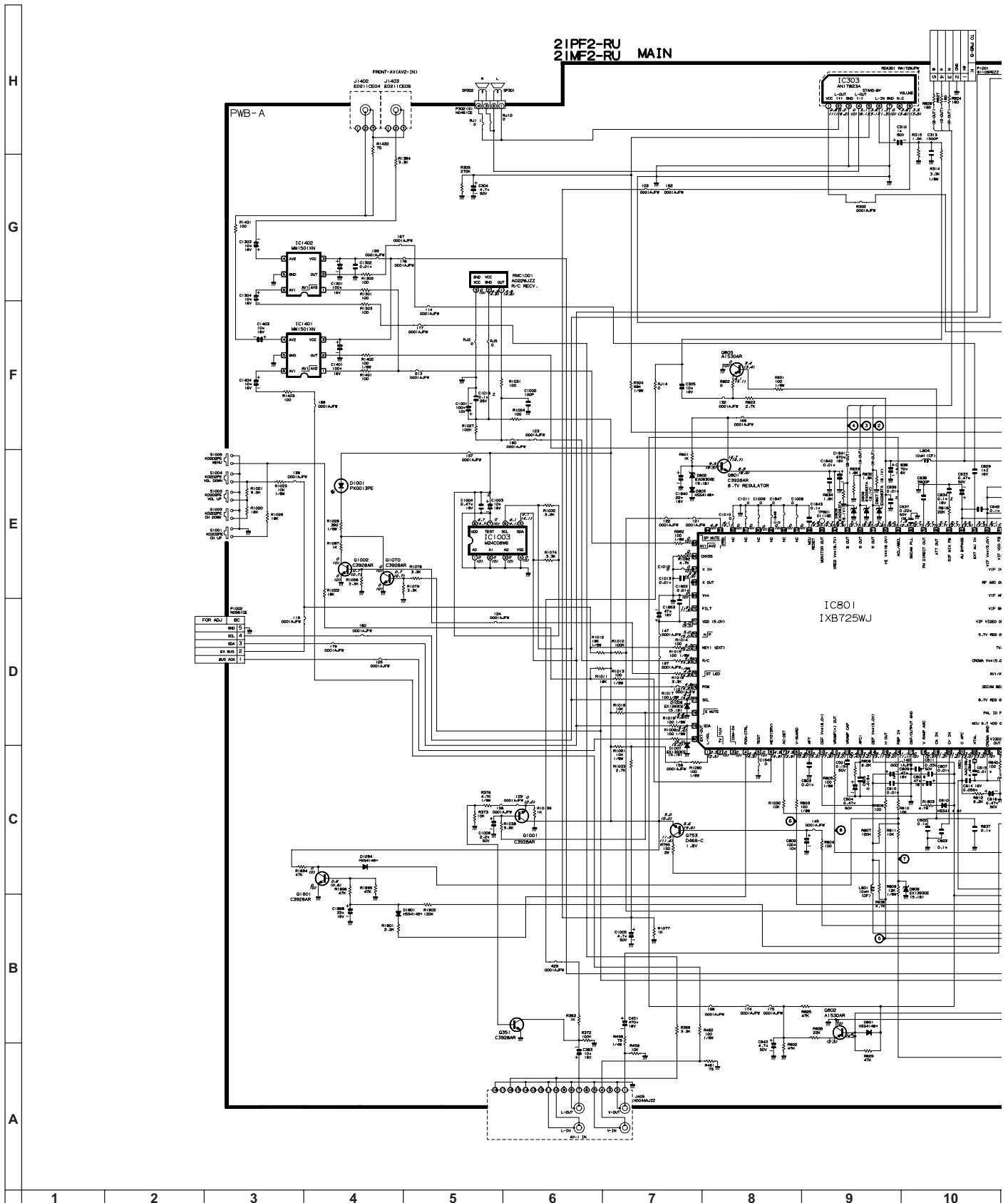

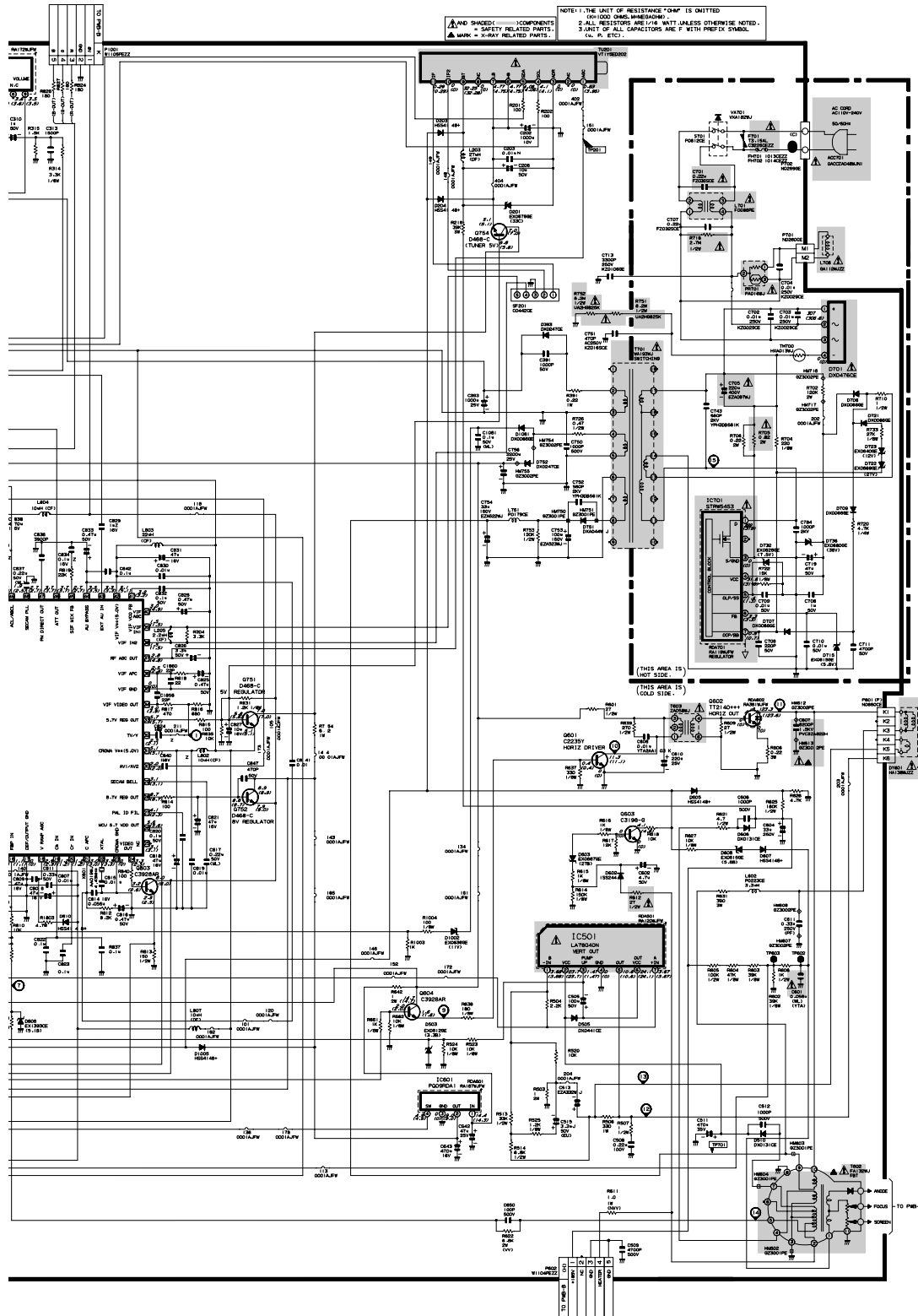

10	11	12	13	14	15	16	17	18	19
----	----	----	----	----	----	----	----	----	----