

Zelio[®] Plug-In Relays

RXM, RPM, RUM, RPF, RSB

Class 8501

Catalog
8501CT0601R1/08

08



CONTENTS

Description	Page
Selection Guide	3
RXM Miniature Relays	4
RPM Miniature Power Relays	13
RUM Universal Relays	21
RPF Power Relays	30
RSB Interface Relays	33
General Technical Information	38
Catalog Number Index	40





RXM●AB2F7

RXM Miniature Relays (page 4)

2 pole relays; 12 A, 1/2 hp (IEC rating = 12 A)
 3 pole relays; 10 A, 1/3 hp (IEC rating = 10 A)
 4 pole relays; 8 A, 1/3 hp (IEC rating = 6 A)
 4 pole relays; 3 A (low level), 1/16 hp (IEC rating = 3 A)

- Mechanical “relay status” indicator on all relays
- Pilot light option available
- Manual operator optional for all relays
- Built-in marking area



RPM32F7

RPM Miniature Power Relays (page 13)

1 pole relays; 15 A, 1/2 hp (IEC rating = 15 A)
 2 pole relays; 15 A, 1/2 hp (IEC rating = 15 A)
 3 pole relays; 15 A, 1/2 hp (IEC rating = 15 A)
 4 pole relays; 15 A, 1/2 hp (IEC rating = 15 A)

- Mechanical “relay status” indicator on all relays
- Pilot light option available
- Manual operator optional for all relays
- Built-in marking area



RUM●●AB2B7

RUM Universal Relays (page 21)

2 pole relays; 8-pin, tube type; 16 A, 1/3 hp (IEC rating = 10 A)
 3 pole relays; 11-pin, tube type; 16 A, 1/3 hp (IEC rating = 10 A)
 2 pole relays; 8 blade type; 16 A, 1/3 hp (IEC rating = 10 A)
 3 pole relays; 11 blade type; 16 A, 1/3 hp (IEC rating = 10 A)

- Mechanical “relay status” indicator on all relays
- Pilot light option available
- Manual operator optional for all relays
- Built-in marking area



RPF2B●●

RPF Power Relays (page 30)

Two Form C contacts; 30 A
 Two Normally Open contacts; 30 A

- DIN track mountable
- Can be mounted directly to a panel



RSB1A160BD
+ RSZE1S48M

RSB Interface Relays (page 33)

Two Form C contacts; 8 A
 One Form C contact; 12 A
 One Form C contact; 16 A

General Technical Information (page 38)

Relay contact types
 Utilization categories
 Protection categories
 Protection modules

Zelio® Plug-in Relays

Product Description

RXM Miniature Relays

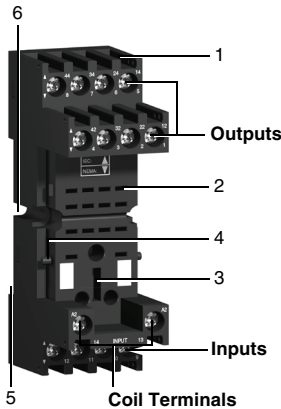
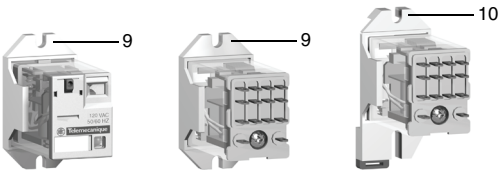
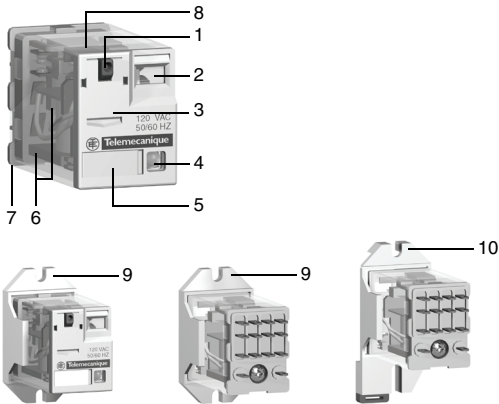
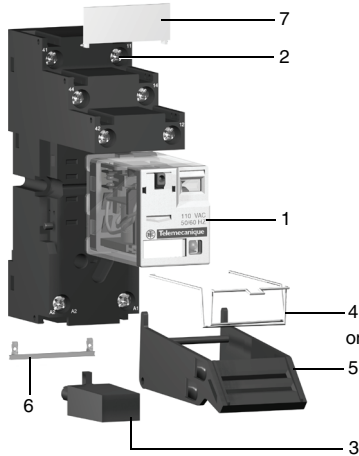

Product Description

The RXM miniature relay range consists of:

- 12 A relays with DPDT contacts, 10 A relays with 3PDT contacts, 6 A relays with 4PDT contacts, and 3 A "low level" relays with 4PDT contacts. All of these relays have the same dimensions.
- Sockets with mixed or separate contact terminals.
- Protection modules (diode, RC circuit or varistor). All these modules are common to all sockets.
- A metal hold-down clip for all sockets.
- A plastic hold-down clip for all sockets.
- A 2-pole bus jumper that can be used on sockets with separate contact terminals to simplify wiring when creating a jumper between the coil terminals.
- Clip-in markers for all the sockets except RXZ E2M114.

Relay Description

- Spring return push button for testing the contacts (green: DC, red: AC).
- Mechanical "relay status" indicator.
- Optional removable lock-down door and push button, enabling forced maintaining of the contacts for test or maintenance purposes. During operation, this lock-down door must always be in the closed position.
- Bipolar LED (depending on version) indicating the relay status.
- Removable marker for relay identification.
- Four notches for DIN rail mounting adapter or panel mounting adapter.
- Eight, eleven, or fourteen pins.
- Area by which the product can be easily gripped.
- Mounting adapter enabling direct mounting of the relay on a panel.
- Mounting adapter enabling direct mounting of the relay on a DIN rail.

Socket Description

Sockets with Mixed Contact Terminals

- Connection by screw clamp terminals or box lug connector.
- Fourteen female contacts for the relay pins.
- Location for protection modules.
- Locking components for plastic and metal hold-down clips.
- Locating slot for mounting on DIN rail.
- Two or four mounting holes for panel mounting.

NOTE: The inputs are mixed with the relay coil terminals, with the outputs being located on the opposite side of the socket.

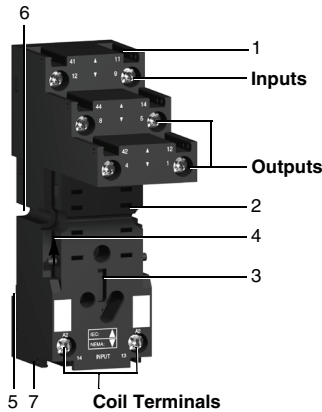

Sockets with Separate Contact Terminals

1. Box lug connector.
2. Eight, eleven, or fourteen female contacts for the relay pins.
3. Location for protection modules.
4. Locking components for plastic and metal hold-down clips.
5. Locating slot for mounting on DIN rail.
6. Two mounting holes for panel mounting.
7. Location for bus jumpers (see mounting on sockets on page 11).

NOTE: The inputs and outputs are separated from the relay coil terminals.

General characteristics

Conforming to standards		IEC/EN 61810-1 (iss. 2), UL 508, CSA C22-2 n° 14
Product certifications		cULus File E164862 CCN NLDX, NLDX7; cURus File E164862 CCN NLDX2, NLDX8; CSA pending; CE; RoHS compliant
Ambient air temperature around the device	Storage	-40–185 °F (-40–85 °C)
	Operation	-40–131 °F (-40–55 °C)
Vibration resistance	Conforming to IEC/EN 60068-2-6	> 6 gn (10–50 Hz)
Degree of protection	Conforming to IEC/EN 60529	IP 40
Shock resistance conforming to IEC/EN 60068-2-27	Opening	10 gn
	Closing	5 gn
Protection category (see page 38)		RT I
Mounting position		Any

Insulation characteristics

Rated insulation voltage (Ui)		250 V (IEC), 300 V (UL, CSA)
Rated impulse withstand voltage (Uimp)		3.6 kV (1.2/50 μs)
Dielectric strength (rms voltage)	Between coil and contact	2,500 Vac
	Between poles	2,500 Vac
	Between contacts	1,500 Vac

Contact characteristics

Relay type		RXM2AB●●●	RXM3AB●●●	RXM4AB●●●	RXM4GB●●●
Number and type of contacts (see page 12)		DPDT	3PDT	4PDT	4PDT
Contact materials		AgNi			AgAu–Bifurcated
Conventional thermal current (Ith)	For ambient temperature ≤ 131 °F (55 °C)	12 A	10 A	6 A	3 A
	Rated operational current	Conforming to IEC in utilization category AC-1	N.O. 6 A	10 A 5 A	6 A 3 A
Conforming to UL Resistive @277 Vac, hp @120 Vac		12 A, 1/2 hp	10 A, 1/3 hp	8 A, 1/3 hp	3 A, 1/16 hp
Maximum operating rate In operating cycles/hour	No load	18,000			
	Under load	1,200			
Switching voltage		Maximum 250 Vac/Vdc			
Switching capacity	Minimum	10 mA on 17 V			2 mA on 5 V
	Maximum	3,000 VA	2,500 VA	1,500 VA	750 VA
Utilization coefficient		20%			
Mechanical durability in millions of operating cycles		10			
Electrical durability in millions of operating cycles		Resistive load 0.1			

Electrical durability of contacts

Resistive load AC

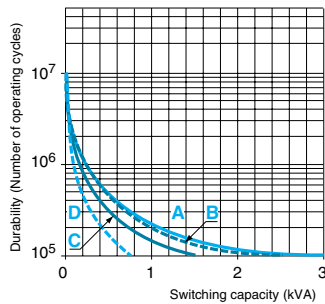

A=RXM2AB●●● B=RXM3AB●●● C=RXM4AB●●● D=RXM4GB●●●

Coil characteristics

Average consumption	AC	1.2 VA									
	DC	0.9 W									
Drop-out voltage threshold	AC	≥ 0.15 Uc									
	DC	≥ 0.1 Uc									
Operating time (response time)	Between coil energization and making of the N.O. contact	AC	20 ms								
		DC	20 ms								
	Between coil de-energization and making of the N.C. contact	AC	20 ms								
		DC	20 ms								
Coil voltage Uc	12 V	24 V	48 V	110 V	120 V	125 V	220 V	230 V	240 V		
Relay coil voltage codes	JD	BD	ED	FD	—	GD	MD	—	—		
DC	Average resistance at 68 °F (20 °C) ± 10%	160 Ω	650 Ω	2,600 Ω	11,000 Ω	—	11,000 Ω	14,000 Ω	—	—	
	Operating voltage limits	Min.	9.6 V	19.2 V	38.4 V	88 V	—	100 V	176 V	—	—
		Max.	13.2 V	26.4 V	52.8 V	121 V	—	138 V	242 V	—	—
Relay coil voltage codes	—	B7	E7	—	F7	—	M7	P7	U7		
AC	Average resistance at 68 °F (20 °C) ± 15%	—	180 Ω	770 Ω	—	4,430 Ω	—	15,000 Ω	15,000 Ω	15,500 Ω	
	Operating voltage limits	Min.	—	19.2 V	38.4 V	—	96 V	—	176 V	184 V	192 V
		Max.	—	26.4 V	52.8 V	—	132 V	—	242 V	253 V	264 V

Socket characteristics

Socket type	RXZE2S108M	RXZE2S111M	RXZE2S114M	RXZE2M114	RXZE2M114M
Relay types used	RXM2●●●●●	RXM3●●●●●	RXM4●●●●●	RXM2●●●●●¹ RXM4●●●●●	RXM2●●●●●¹ RXM4●●●●●
Product certifications	cURus File E172326 CCN SWIV2, SWIV8; CSA (pending); CE; RoHS compliant				
Conventional thermal current (Ith)	12 A	10 A			
Degree of protection	Conforming to IEC/EN 60529 IP 20				
Connection	Solid wire without cable end	1 conductor: AWG 20–12 (0.5–2.5 mm ²) 2 conductors: AWG 20–14 (0.5–1.5 mm ²)			
	Flexible wire with cable end	1 conductor: AWG 24–14 (0.2–2.5 mm ²) 2 conductors: AWG 24–16 (0.2–1.5 mm ²)			
	Flexible wire without cable end	1 conductor: AWG 24–14 (0.2–2.5 mm ²) 2 conductors: AWG 24–16 (0.2–1.5 mm ²)			
Maximum tightening torque	5.3 lbf-in (0.6 Nm) (M3 screw)				
Contact terminal arrangement	Separate			Mixed	
Bus jumper Ith: 5 A	Yes			No	

¹ When mounting relay RXM2●●●●● on socket RXZE2M●●●●●, the thermal current must not exceed 10 A.



RXM2AB2F7

Miniature relays with lockable test button, without LED (sold in lots of 10)

Coil Voltage	Number and type of contacts - Thermal current (Ith)									
	DPDT - 12 A				3PDT - 10 A			4PDT - 6 A		
	Catalog Number	Weight		Catalog Number	Weight		Catalog Number	Weight		
lb.		kg	lb.		kg	lb.		kg		
12 Vdc	RXM2AB1JD	0.082	0.037	RXM3AB1JD	0.084	0.038	RXM4AB1JD	0.080	0.036	
24 Vdc	RXM2AB1BD	0.082	0.037	RXM3AB1BD	0.084	0.038	RXM4AB1BD	0.080	0.036	
48 Vdc	RXM2AB1ED	0.082	0.037	RXM3AB1ED	0.084	0.038	RXM4AB1ED	0.080	0.036	
110 Vdc	RXM2AB1FD	0.082	0.037	RXM3AB1FD	0.084	0.038	RXM4AB1FD	0.080	0.036	
220 Vdc	—	—	—	—	—	—	RXM4AB1MD	0.080	0.036	
24 Vac	RXM2AB1B7	0.082	0.037	RXM3AB1B7	0.084	0.038	RXM4AB1B7	0.080	0.036	
48 Vac	RXM2AB1E7	0.082	0.037	RXM3AB1E7	0.084	0.038	RXM4AB1E7	0.080	0.036	
120 Vac	RXM2AB1F7	0.082	0.037	RXM3AB1F7	0.084	0.038	RXM4AB1F7	0.080	0.036	
230 Vac	RXM2AB1P7	0.082	0.037	RXM3AB1P7	0.084	0.038	RXM4AB1P7	0.080	0.036	
240 Vac	—	—	—	—	—	—	RXM4AB1U7	0.080	0.036	

Miniature relays with lockable test button, with LED (sold in lots of 10)

12 Vdc	RXM2AB2JD	0.082	0.037	RXM3AB2JD	0.084	0.038	RXM4AB2JD	0.080	0.036
24 Vdc	RXM2AB2BD	0.082	0.037	RXM3AB2BD	0.084	0.038	RXM4AB2BD	0.080	0.036
48 Vdc	RXM2AB2ED	0.082	0.037	RXM3AB2ED	0.084	0.038	RXM4AB2ED	0.080	0.036
110 Vdc	RXM2AB2FD	0.082	0.037	RXM3AB2FD	0.084	0.038	RXM4AB2FD	0.080	0.036
125 Vdc	—	—	—	—	—	—	RXM4AB2GD	0.080	0.036
24 Vac	RXM2AB2B7	0.082	0.037	RXM3AB2B7	0.084	0.038	RXM4AB2B7	0.080	0.036
48 Vac	RXM2AB2E7	0.082	0.037	RXM3AB2E7	0.084	0.038	RXM4AB2E7	0.080	0.036
120 Vac	RXM2AB2F7	0.082	0.037	RXM3AB2F7	0.084	0.038	RXM4AB2F7	0.080	0.036
230 Vac	RXM2AB2P7	0.082	0.037	RXM3AB2P7	0.084	0.038	RXM4AB2P7	0.080	0.036



RXM4GB2F7

Miniature relays with low level contacts, without LED (sold in lots of 10)

Number and type of contacts - Thermal current (Ith)				
4PDT - 3 A				
Coil Voltage	Catalog Number	Weight		
		lb.	kg	
12 Vdc	RXM4GB1JD	0.080	0.036	
24 Vdc	RXM4GB1BD	0.080	0.036	
48 Vdc	RXM4GB1ED	0.080	0.036	
110 Vdc	RXM4GB1FD	0.080	0.036	
24 Vac	RXM4GB1B7	0.080	0.036	
48 Vac	RXM4GB1E7	0.080	0.036	
120 Vac	RXM4GB1F7	0.080	0.036	
230 Vac	RXM4GB1P7	0.080	0.036	

Miniature relays with low level contacts, with LED (sold in lots of 10)

Number and type of contacts - Thermal current (Ith)				
4PDT - 3 A				
Coil Voltage	Catalog Number	Weight		
		lb.	kg	
12 Vdc	RXM4GB2JD	0.080	0.036	
24 Vdc	RXM4GB2BD	0.080	0.036	
48 Vdc	RXM4GB2ED	0.080	0.036	
110 Vdc	RXM4GB2FD	0.080	0.036	
24 Vac	RXM4GB2B7	0.080	0.036	
48 Vac	RXM4GB2E7	0.080	0.036	
120 Vac	RXM4GB2F7	0.080	0.036	
230 Vac	RXM4GB2P7	0.080	0.036	
240 Vac	RXM4GB2U7	0.080	0.036	



RXM●AB3F7

Miniature relays without lockable test button, with LED

Coil Voltage	Number and Type of Contacts—Thermal Current (Ith)					
	DPDT - 12 A			4PDT - 6 A		
	Catalog No.	Weight		Catalog No.	Weight	
lb.		kg	lb.		kg	
Sold in lots of 10						
12 Vdc	RXM2AB3JD	0.082	0.037	RXM4AB3JD	0.080	0.036
24 Vdc	RXM2AB3BD	0.082	0.037	RXM4AB3BD	0.080	0.036
48 Vdc	RXM2AB3ED	0.082	0.037	RXM4AB3ED	0.080	0.036
110 Vdc	RXM2AB3FD	0.082	0.037	RXM4AB3FD	0.080	0.036
125 Vdc	—	—	—	RXM4AB3GD	0.080	0.036
24 Vac	RXM2AB3B7	0.082	0.037	RXM4AB3B7	0.080	0.036
48 Vac	RXM2AB3E7	0.082	0.037	RXM4AB3E7	0.080	0.036
120 Vac	RXM2AB3F7	0.082	0.037	RXM4AB3F7	0.080	0.036
230 Vac	RXM2AB3P7	0.082	0.037	RXM4AB3P7	0.080	0.036
Sold in lots of 100						
24 Vdc	RXM2AB3BDTQ	0.082	0.037	RXM4AB3BDTQ	0.080	0.036
24 Vac	RXM2AB3B7TQ	0.082	0.037	RXM4AB3B7TQ	0.080	0.036
230 Vac	RXM2AB3P7TQ	0.082	0.037	RXM4AB3P7TQ	0.080	0.036

Miniature relays with low level contacts,
without lockable test button, with LED

Coil Voltage	4PDT (low level) - 3 A		
	Catalog No.	Weight	
		lb.	kg
Sold in lots of 10			
12 Vdc	RXM4GB3JD	0.080	0.036
24 Vdc	RXM4GB3BD	0.080	0.036
48 Vdc	RXM4GB3ED	0.080	0.036
110 Vdc	RXM4GB3FD	0.080	0.036
125 Vdc	—	—	—
24 Vac	RXM4GB3B7	0.080	0.036
48 Vac	RXM4GB3E7	0.080	0.036
120 Vac	RXM4GB3F7	0.080	0.036
230 Vac	RXM4GB3P7	0.080	0.036

See page 9 for sockets and accessories.



RXZ E2M114M with relay RXM4AB2P7TQ



RXZ E2S114M with relay RXM4AB2F7TQ

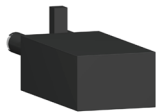

RXM 041



REXL4



RXZ400

Miniature relays with lockable test button, without LED (sold in lots of 100)

Coil Voltage	Number and type of contacts - Thermal current (Ith)					
	DPDT - 12 A			4PDT - 6 A		
	Catalog Number	Weight		Catalog Number	Weight	
		lb.	kg		lb.	kg
12 Vdc	—	—	—	RXM4AB1JDTQ	0.080	0.036
24 Vdc	RXM2AB1BDTQ	0.082	0.037	RXM4AB1BDTQ	0.080	0.036
48 Vdc	—	—	—	RXM4AB1EDTQ	0.080	0.036
110 Vdc	—	—	—	RXM4AB1FDTQ	0.080	0.036
220 Vdc	—	—	—	RXM4AB1MDTQ	0.080	0.036
24 Vac	RXM2AB1B7TQ	0.082	0.037	RXM4AB1B7TQ	0.080	0.036
48 Vac	—	—	—	RXM4AB1E7TQ	0.080	0.036
120 Vac	RXM2AB1F7TQ	0.082	0.037	RXM4AB1F7TQ	0.080	0.036
230 Vac	RXM2AB1P7TQ	0.082	0.037	RXM4AB1P7TQ	0.080	0.036

Miniature relays with LED (sold in lots of 100)

24 Vdc	—	—	—	RXM4AB2BDTQ	0.080	0.036
24 Vac	RXM2AB2B7TQ	0.082	0.037	RXM4AB2B7TQ	0.080	0.036
230 Vac	RXM2AB2P7TQ	0.082	0.037	RXM4AB2P7TQ	0.080	0.036

Sockets (sold in lots of 10)

Contact terminal arrangement	Connection	Relay type	Catalog Number	Weight	
				lb.	kg
Mixed	Screw clamp terminals	RXM2●●●● ¹ RXM4●●●●	RXZE2M114 ²	0.11	0.048
	Box lug connector	RXM2●●●● ¹ RXM4●●●●	RXZE2M114M ²	0.12	0.056
Separate	Box lug connector	RXM2●●●●	RXZE2S108M ³	0.13	0.058
		RXM3●●●●	RXZE2S111M ²	0.15	0.066
		RXM4●●●●	RXZE2S114M ²	0.15	0.070

¹ When mounting relay RXM2●●●● on socket RXZE2M●●●●, the thermal current must not exceed 10 A.

² Thermal current Ith: 10 A

³ Thermal current Ith: 12 A

Protection modules (sold in lots of 20)

Description	Voltage	For use with	Catalog Number	Weight	
				oz.	g
Diode	6–250 Vdc	All sockets	RXM040W	0.11	3.0
RC circuit	24–60 Vac	All sockets	RXM041BN7	0.35	10.0
	110–240 Vac	All sockets	RXM041FU7	0.35	10.0
Varistor	6–24 Vac/Vdc	All sockets	RXM021RB	1.06	30.0
	24–60 Vac/Vdc	All sockets	RXM021BN	1.06	30.0
	110–240 Vac/Vdc	All sockets	RXM021FP	1.06	30.0

Timing relays

Description	For use with	Catalog Number	Weight	
			lb.	kg
2 timed DPDT contacts (function A—On-delay)	Sockets RXZ E●●●●●	REXL2●● ⁴	0.09	0.042
4 timed 4PDT contacts (function A—On-delay)		REXL4●● ⁴	0.09	0.042

⁴ Please refer to the *Zelio® Time - Timers* catalog (9050CT0001R2/05).

Accessories (sold in lots of 10)

Description	For use with	Catalog Number	Weight	
			oz.	g
Metal hold-down clip	All sockets	RXZ400	0.04	1.0
Plastic hold-down clip	All sockets	RXZR335	0.18	5.0
Bus jumper, 2-pole (Ith: 5 A)	All sockets with separate contacts	RXZS2	0.18	5.0
Mounting adapter for DIN rail ⁵	All relays	RXZE2DA	0.14	4.0
Mounting adapter for mounting directly to a panel	All relays	RXZE2FA	0.07	2.0
Clip-in markers	All relays (sheet of 108 markers)	RXZL520	2.82	80.0
	All sockets except RXZE2M114	RXZL420	0.04	1.0

⁵ Test button becomes inaccessible.

Zelio® Plug-in Relays

Dimensions

RXM Miniature Relays

Relays

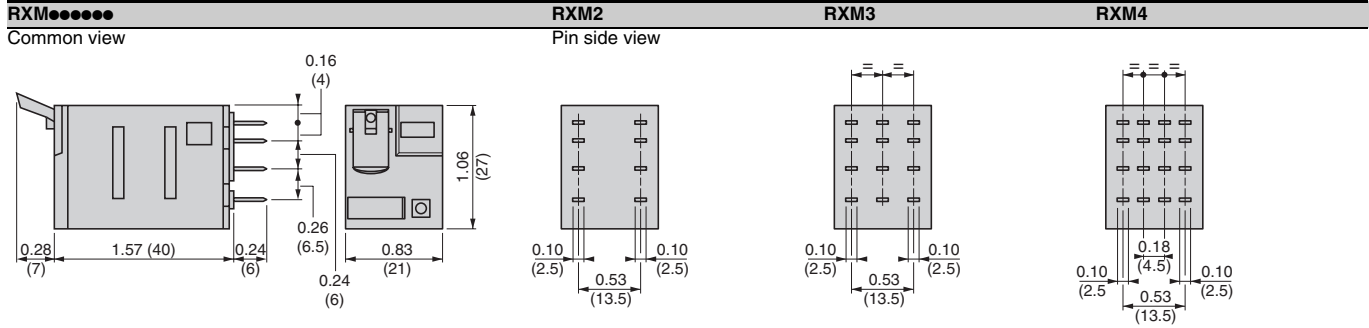

Sockets

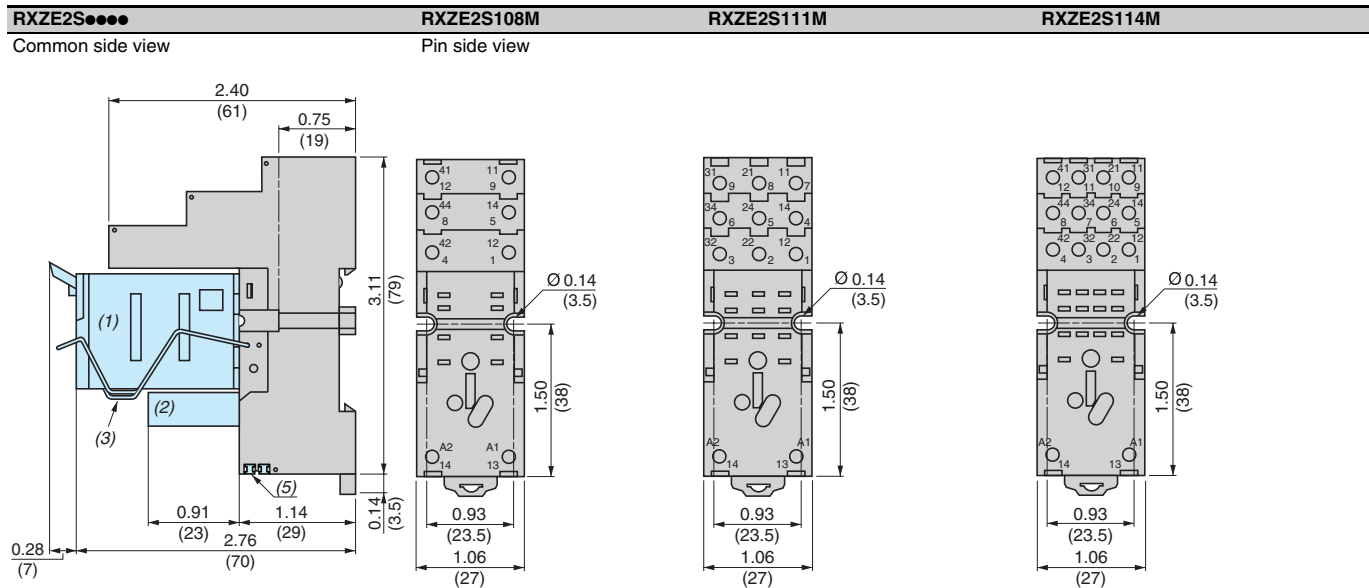
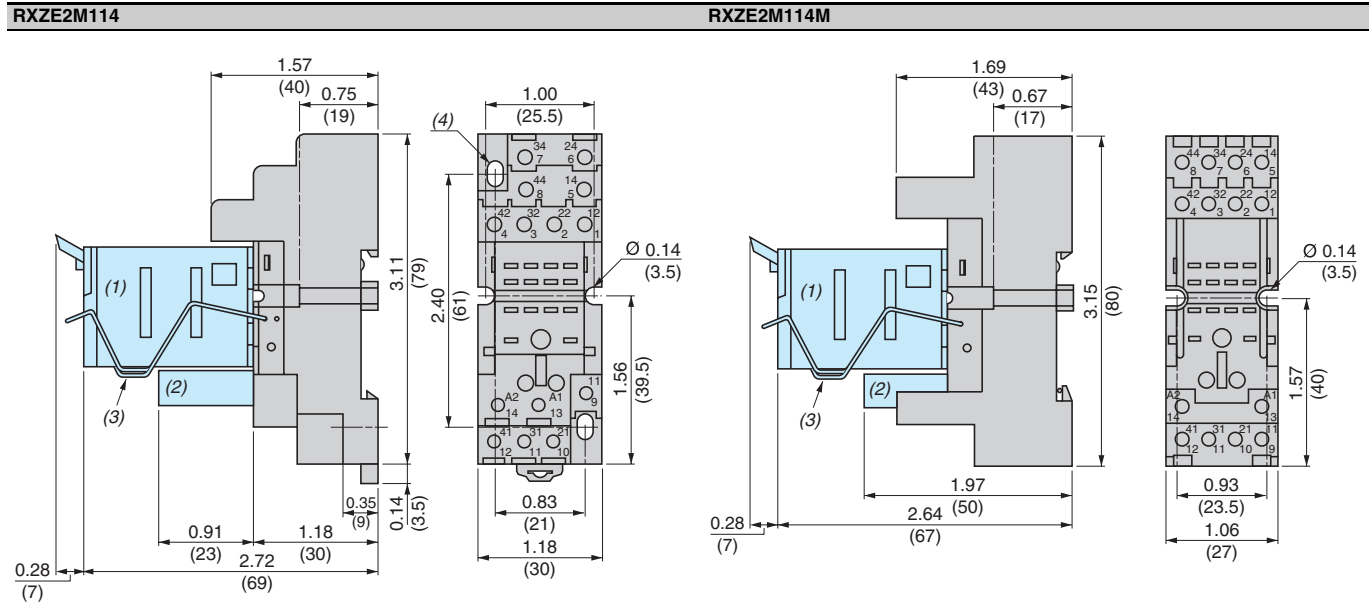

- (1) Relays
- (2) Add-on protection module
- (3) Hold-down clip
- (4) 2 elongated holes Ø 0.14 x 0.26 (3.5 x 6.5)
- (5) 2 bus jumpers

Dimensions = Inches
(mm)

Plastic clamp and clip-in markers

RXZR335	RXZL420	Mounting on all sockets
---------	---------	-------------------------

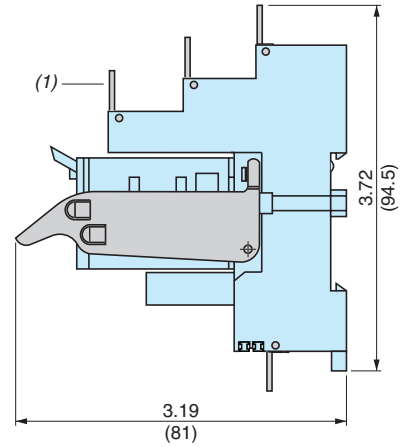
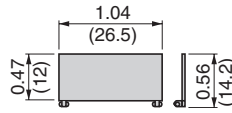
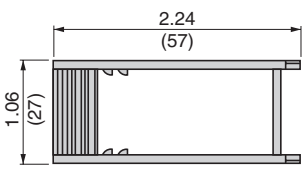

(1) Clip-in markers for all sockets except RXZE2M114.

Bus jumper

RXZS2	Mounting on sockets with separate contacts (view from below)	Metal clamp RXZ400
-------	---	-----------------------

Example of bus jumper mounting on sockets

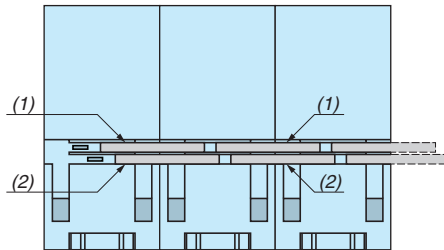
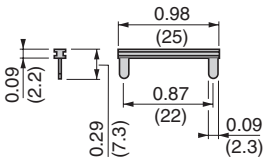

(1) 2 bus jumpers (polarity A2)
(2) 2 bus jumpers (polarity A1)

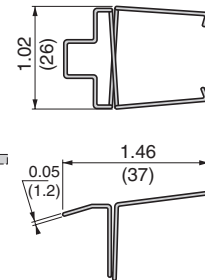

Mounting adapter for rail¹

RXZE2DA	Mounting adapter for panel RXZE2FA
---------	---------------------------------------

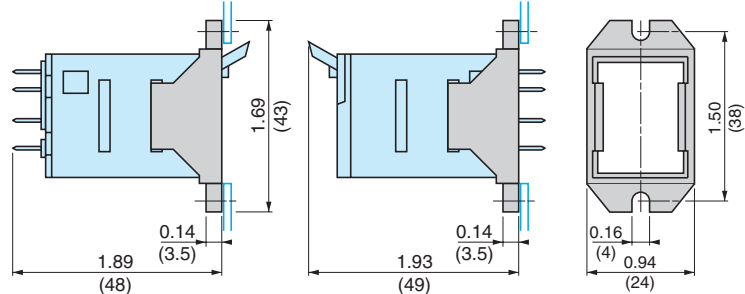
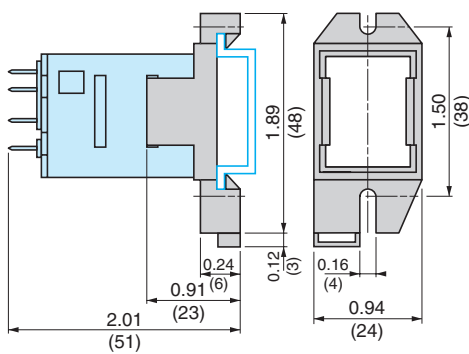

¹ Test button becomes inaccessible

Dimensions = Inches
(mm)

Miniature relays

RXM2●●●●●

RXM3●●●●●

RXM4●●●●●

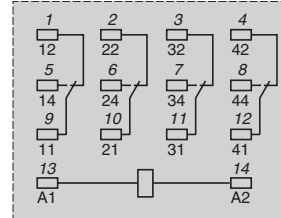
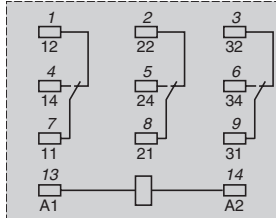
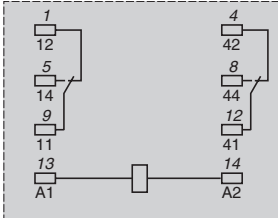
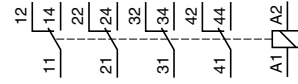
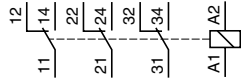
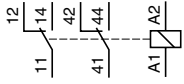

Numbers shown in *italics* correspond to NEMA marking. Viewed from pin end.

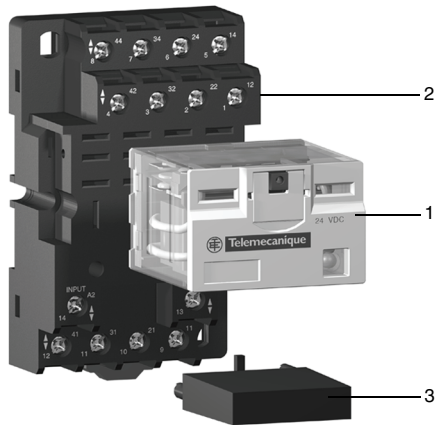

Product Description

The RPM miniature relay range consists of:

1. 15 A relays with SPDT, DPDT, 3PDT, and 4PDT contacts.
2. Sockets with mixed contact terminals.
3. Protection modules (diode, RC circuit, or varistor) or 1 timer module. All these modules are common to all the sockets except for the timer module, which can only be used on the 3-pole or 4-pole sockets.
4. A metal hold-down clip for SPDT relays.

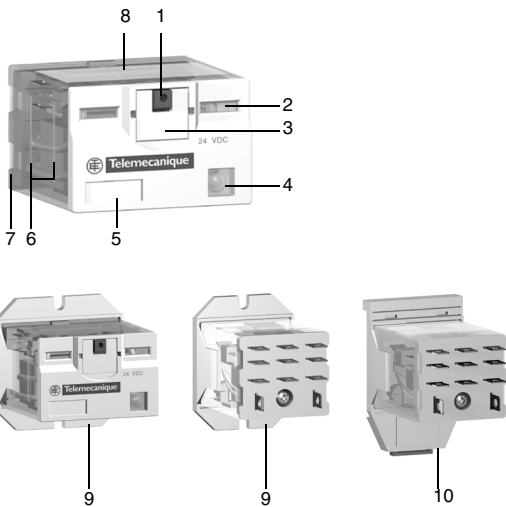

Relay Description

1. Spring return push button for testing the contacts (green: DC, red: AC).
2. Mechanical “relay status” indicator.
3. Optional removable lock-down door and push button, enabling forced maintaining of the contacts for test or maintenance purposes. During operation, this lock-down door must always be in the closed position.
4. Bipolar LED (depending on version) indicating the relay status.
5. Removable legend for relay identification.
6. Four notches for DIN rail mounting adapter or panel mounting adapter.
7. Five, eight, eleven, or fourteen pins.
8. Area by which the product can be easily gripped.
9. Mounting adapter enabling direct mounting of the relay on a panel.
10. Mounting adapter enabling direct mounting of the relay on a DIN rail.

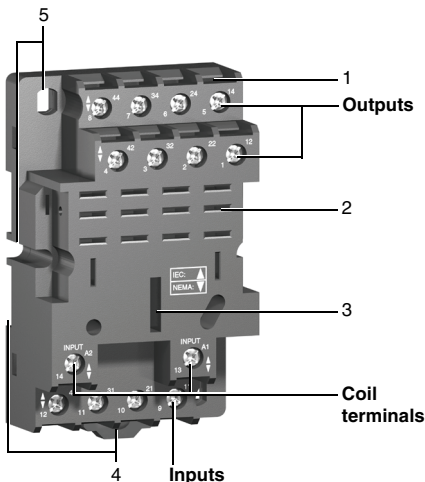

Socket Description

Sockets with mixed contact terminals

1. Connection by screw clamp terminals.
2. Five, eight, eleven, or fourteen female contacts for the relay pins.
3. Location for protection modules or the timer module.
4. Locating slot for mounting on DIN rail with mounting clip.
5. Two or four mounting holes for panel mounting.

NOTE: The inputs are mixed with the relay coil terminals, with the outputs being located on the opposite side of the socket.

General characteristics

Conforming to standards	IEC/EN 61810-1 (iss. 2), UL 508, CSA C22-2 n° 14	
Product certifications	cULus File E164862 GCN NLDX, NLDX7; cURus File E164862 GCN NLDX2, NLDX8; CSA pending; CE; RoHS compliant	
Ambient air temperature around the device	Storage	-40–185 °F (-40–85 °C)
	Operation	-40–131 °F (-40–55 °C)
Vibration resistance	Conforming to IEC/EN 60068-2-6	6 gn (10–50 Hz)
Degree of protection	Conforming to IEC/EN 60529	IP 40
Shock resistance conforming to IEC/EN 60068-2-27	Opening	10 gn
	Closing	10 gn
Protection category (see page 38)	RT I	
Mounting position	Any	

Insulation characteristics

Rated insulation voltage (Ui)	Conforming to IEC/EN 60947	250 V (IEC), 300 V (UL, CSA)
Rated impulse withstand voltage (Uimp)	3.6 kV (1.2/50 µs)	
Dielectric strength (rms voltage)	Between coil and contact	2,500 Vac
	Between poles	2,500 Vac
	Between contacts	1,500 Vac

Contact characteristics

Relay type	RPM1●●●	RPM2●●●	RPM3●●●	RPM4●●●
Number and type of contacts (see page 20)	SPDT	DPDT	3PDT	4PDT
Contact materials	AgNi			
Conventional thermal current (Ith)	For ambient temperature ≤ 131 °F (55 °C)			
	15 A			
Rated operational current	Conforming to IEC in utilization category AC-1			
	N.O. N.C.			
	7.5 A			
Maximum operating rate In operating cycles/hour	Conforming to UL Resistive @277 Vac, hp @ 120 Vac			
	15 A, 1/2 hp			
Switching voltage	No load			
	18,000			
Switching capacity	Under load			
	1,200			
Switching capacity	Maximum			
	250 Vac/Vdc			
Switching capacity	Minimum			
	10 mA on 17 V			
Switching capacity	Maximum			
	3,750 VA			
Utilization coefficient	20%			
Mechanical durability in millions of operating cycles	10			
Electrical durability in millions of operating cycles	Resistive load			0.06

Electrical durability of contacts

Resistive load AC

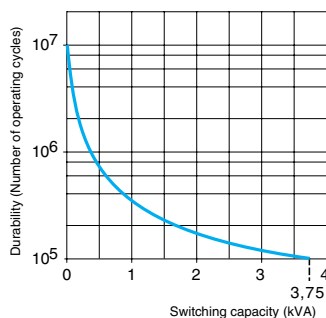

Coil characteristics

Relay type		RPM1●●●	RPM2●●●	RPM3●●●	RPM4●●●			
Average consumption	AC	0.9 VA	1.2 VA	1.5 VA	1.5 VA			
	DC	0.7 W	0.9 W	1.7 W	2 W			
Drop-out voltage threshold	AC	≥ 0.15 U _c						
	DC	≥ 0.1 U _c						
Operating time (response time)	Between coil energization and making of the N.O. contact	AC	20 ms	25 ms	25 ms	20 ms		
		DC	20 ms	25 ms	25 ms	20 ms		
	Between coil de-energization and making of the N.C. contact	AC	20 ms					
		DC	20 ms					
Control circuit voltage U _c		12 V	24 V	48 V	110 V	120 V	230 V	
Relay control voltage codes		JD	BD	ED	FD	—	—	
DC	Average resistance at 68 °F (20 °C) ± 10%	RPM1●●●	180 Ω	750 Ω	2,600 Ω	13,100 Ω	—	—
		RPM2●●●	160 Ω	650 Ω	2,600 Ω	11,000 Ω	—	—
		RPM3●●●	100 Ω	400 Ω	2,600 Ω	8,600 Ω	—	—
		RPM4●●●	96 Ω	388 Ω	1,550 Ω	7,340 Ω	—	—
	Operating voltage limits	Min.	9.6 V	19.2 V	38.4 V	88 V	—	—
		Max.	13.2 V	26.4 V	52.8 V	121 V	—	—
Relay control voltage codes		—	B7	E7	—	F7	P7	
AC	Average resistance at 68 °F (20 °C) ± 15%	RPM1●●●	—	160 Ω	720 Ω	—	4,430 Ω	15,720 Ω
		RPM2●●●	—	180 Ω	770 Ω	—	4,430 Ω	15,000 Ω
		RPM3●●●	—	103 Ω	770 Ω	—	2,770 Ω	12,000 Ω
		RPM4●●●	—	84.3 Ω	338 Ω	—	2,220 Ω	9,120 Ω
	Operating voltage limits	Min.	—	19.2 V	38.4 V	—	96 V	184 V
		Max.	—	26.4 V	52.8 V	—	132 V	253 V

Socket characteristics

Socket type		RPZF1	RPZF2	RPZF3	RPZF4	
Relay types used		RPM1●●●	RPM2●●●	RPM3●●●	RPM4●●●	
Protection module types used		RXM02●●● RXM04●●●	RXM02●●● RXM04●●●	RUW24●●●	RUW24●●●	
Product certifications		cURus File E172326 CCN SWIV2, SWIV8; CSA (pending); CE; RoHS compliant				
Conventional thermal current (I _{th})		16 A				
Degree of protection		Conforming to IEC/EN 60529 IP 20				
Connection	Solid wire without cable end	1 conductor: AWG 20–12 (0.5–2.5 mm ²) 2 conductors: AWG 20–14 (0.5–1.5 mm ²)				
	Flexible wire with cable end	1 conductor: AWG 24–14 (0.2–2.5 mm ²) 2 conductors: AWG 24–16 (0.2–1.5 mm ²)				
	Flexible wire without cable end	1 conductor: AWG 24–14 (0.2–2.5 mm ²) 2 conductors: AWG 24–16 (0.2–1.5 mm ²)				
Maximum tightening torque		7.1 lbf-in (0.8 N•m) (M3.5 screw)				
Contact terminal arrangement		Mixed				

Power relays with lockable test button, without LED (sold in lots of 10)

Number and type of contacts - Thermal current (Ith)												
	SPDT - 15 A			DPDT - 15 A			3PDT - 15 A			4PDT - 15 A		
Coil Voltage	Catalog Number	Weight		Catalog Number	Weight		Catalog Number	Weight		Catalog Number	Weight	
		lb.	kg		lb.	kg		lb.	kg		lb.	kg
12 Vdc	RPM11JD	0.05	0.024	RPM21JD	0.08	0.036	RPM31JD	0.12	0.054	RPM41JD	0.15	0.068
24 Vdc	RPM11BD	0.05	0.024	RPM21BD	0.08	0.036	RPM31BD	0.12	0.054	RPM41BD	0.15	0.068
48 Vdc	RPM11ED	0.05	0.024	RPM21ED	0.08	0.036	RPM31ED	0.12	0.054	RPM41ED	0.15	0.068
110 Vdc	RPM11FD	0.05	0.024	RPM21FD	0.08	0.036	RPM31FD	0.12	0.054	RPM41FD	0.15	0.068
24 Vac	RPM11B7	0.05	0.024	RPM21B7	0.08	0.036	RPM31B7	0.12	0.054	RPM41B7	0.15	0.068
48 Vac	RPM11E7	0.05	0.024	RPM21E7	0.08	0.036	RPM31E7	0.12	0.054	RPM41E7	0.15	0.068
120 Vac	RPM11F7	0.05	0.024	RPM21F7	0.08	0.036	RPM31F7	0.12	0.054	RPM41F7	0.15	0.068
230 Vac	RPM11P7	0.05	0.024	RPM21P7	0.08	0.036	RPM31P7	0.12	0.054	RPM41P7	0.15	0.068



RPM22F7

Power relays with lockable test button, with LED (sold in lots of 10)

12 Vdc	RPM12JD	0.05	0.024	RPM22JD	0.08	0.036	RPM32JD	0.12	0.054	RPM42JD	0.15	0.068
24 Vdc	RPM12BD	0.05	0.024	RPM22BD	0.08	0.036	RPM32BD	0.12	0.054	RPM42BD	0.15	0.068
48 Vdc	RPM12ED	0.05	0.024	RPM22ED	0.08	0.036	RPM32ED	0.12	0.054	RPM42ED	0.15	0.068
110 Vdc	RPM12FD	0.05	0.024	RPM22FD	0.08	0.036	RPM32FD	0.12	0.054	RPM42FD	0.15	0.068
24 Vac	RPM12B7	0.05	0.024	RPM22B7	0.08	0.036	RPM32B7	0.12	0.054	RPM42B7	0.15	0.068
48 Vac	RPM12E7	0.05	0.024	RPM22E7	0.08	0.036	RPM32E7	0.12	0.054	RPM42E7	0.15	0.068
120 Vac	RPM12F7	0.05	0.024	RPM22F7	0.08	0.036	RPM32F7	0.12	0.054	RPM42F7	0.15	0.068
230 Vac	RPM12P7	0.05	0.024	RPM22P7	0.08	0.036	RPM32P7	0.12	0.054	RPM42P7	0.15	0.068



RPM32F7

Power relays without lockable test button, with LED

Number and type of contacts - Thermal current (Ith)												
	SPDT - 15 A			DPDT - 15 A			3PDT - 15 A			4PDT - 15 A		
Coil Voltage	Catalog Number	Weight		Catalog Number	Weight		Catalog Number	Weight		Catalog Number	Weight	
		lb.	kg		lb.	kg		lb.	kg		lb.	kg
Sold in lots of 10												
12 Vdc	RPM13JD	0.05	0.024	RPM23JD	0.08	0.036	RPM33JD	0.12	0.054	RPM43JD	0.15	0.068
24 Vdc	RPM13BD	0.05	0.024	RPM23BD	0.08	0.036	RPM33BD	0.12	0.054	RPM43BD	0.15	0.068
48 Vdc	RPM13ED	0.05	0.024	RPM23ED	0.08	0.036	RPM33ED	0.12	0.054	RPM43ED	0.15	0.068
110 Vdc	RPM13FD	0.05	0.024	RPM23FD	0.08	0.036	RPM33FD	0.12	0.054	RPM43FD	0.15	0.068
24 Vac	RPM13B7	0.05	0.024	RPM23B7	0.08	0.036	RPM33B7	0.12	0.054	RPM43B7	0.15	0.068
48 Vac	RPM13E7	0.05	0.024	RPM23E7	0.08	0.036	RPM33E7	0.12	0.054	RPM43E7	0.15	0.068
120 Vac	RPM13F7	0.05	0.024	RPM23F7	0.08	0.036	RPM33F7	0.12	0.054	RPM43F7	0.15	0.068
230 Vac	RPM13P7	0.05	0.024	RPM23P7	0.08	0.036	RPM33P7	0.12	0.054	RPM43P7	0.15	0.068



RPM43BD

See page 17 for sockets and accessories.



RPZF2 + relay RPM22F7

Sockets (sold in lots of 10)

Contact terminal arrangement	Connection	Relay type	Catalog Number	Weight	
				lb.	kg
Mixed	Screw clamp terminals	RPM1●●●	RPZF1	0.09	0.042
		RPM2●●●	RPZF2	0.12	0.064
		RPM3●●●	RPZF3	0.16	0.072
		RPM4●●●	RPZF4	0.21	0.094

Protection modules



RXM041●●●

Description	Voltage	For use with	Sold in lots of	Catalog Number	Weight	
					oz.	g
Diode	6–250 Vdc	RPZF1 RPZF2	20	RXM040W	0.11	3.0
		RPZF3 RPZF4	10	RUW240BD	0.14	4.0
RC circuit	24–60 Vac	RPZF1 RPZF2	20	RXM041BN7	0.35	10.0
	110–240 Vac	RPZF1 RPZF2	20	RXM041FU7	0.35	10.0
		RPZF3 RPZF4	10	RUW241P7	0.14	4.0
	Varistor	6–24 Vac/Vdc	RPZF1 RPZF2	20	RXM021RB	0.11
24–60 Vac/Vdc		RPZF1 RPZF2	20	RXM021BN	0.11	3.0
110–240 Vac/Vdc		RPZF1 RPZF2	20	RXM021FP	0.11	3.0
24 Vac/Vdc		RPZF3 RPZF4	10	RUW242B7	0.14	4.0
240 Vac/Vdc		RPZF3 RPZF4	10	RUW242P7	0.14	4.0

Timer module ¹ (sold in lots of 10)

Description	Voltage	Socket Type	Catalog Number	Weight	
				lb.	kg
Multifunction	24–240 Vac/Vdc	RPZF3 RPZF4	RUW101MW	0.04	0.02

¹ See timer module description (selection of functions and time delays) on page 29.

Accessories (sold in lots of 10)



RPZ1DA



RPZ3FA

Description	For use with	Catalog Number	Weight	
			oz.	g
Metal hold-down clip (for single-pole relays)	RPZF1	RPZR235	0.04	1.0
Mounting adapters for DIN rail ²	RPM1●●●	RPZ1DA	0.14	4.0
	RPM2●●●	RXZE2DA	0.14	4.0
	RPM3●●●	RPZ3DA	0.14	4.0
	RPM4●●●	RPZ4DA	0.21	6.0
Mounting adapters for mounting directly to a panel	RPM1●●●	RPZ1FA	0.07	2.0
	RPM2●●●	RXZE2FA	0.07	2.0
	RPM3●●●	RPZ3FA	0.11	3.0
	RPM4●●●	RPZ4FA	0.14	4.0
Clip-in markers (sheet of 108 markers)	All relays	RXZL520	2.82	80

² Test button becomes inaccessible.

Zelio® Plug-in Relays

Dimensions

RPM Miniature Power Relays

Power relays

RPM1

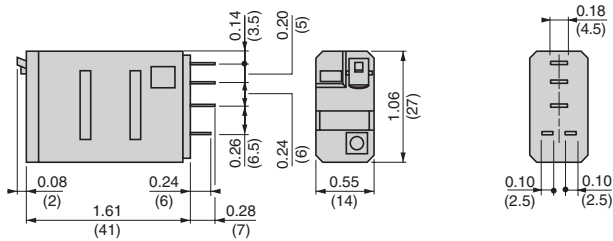

Dimensions = Inches
(mm)

Common side view

RPM2

RPM3

RPM4

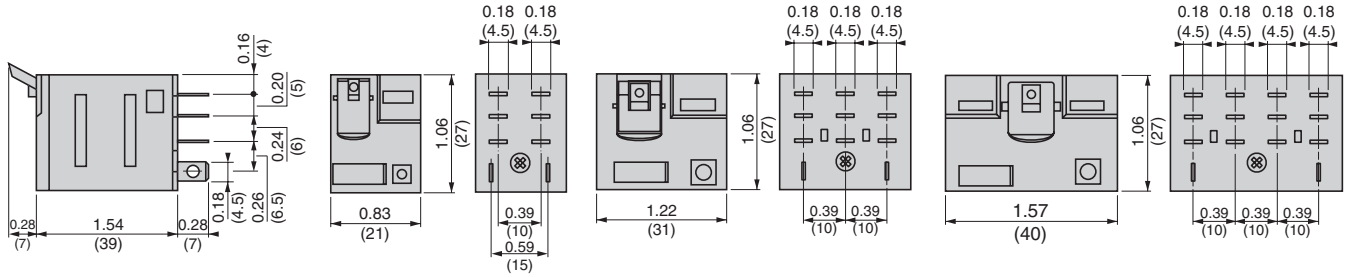

Sockets

RPZF1

RPZF2

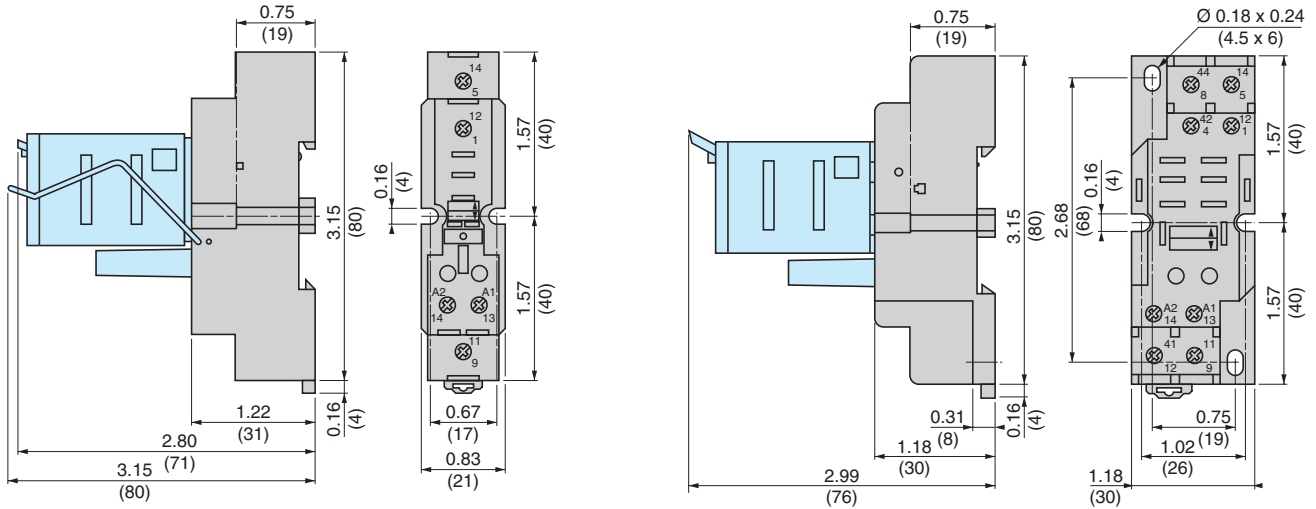

Common side view

RPZF3

RPZF4

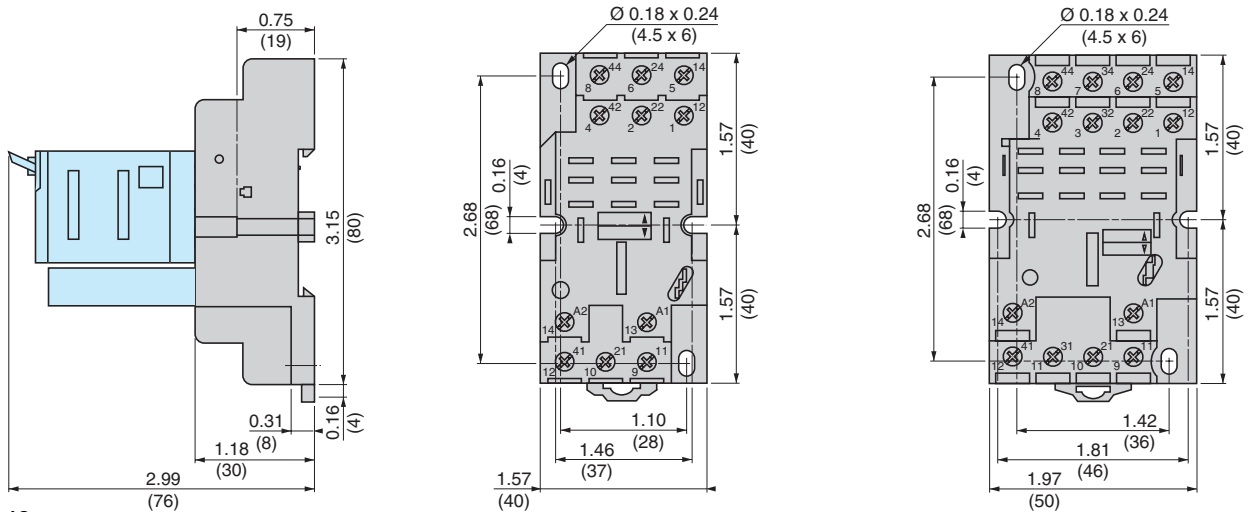

Mounting adapters for DIN rail

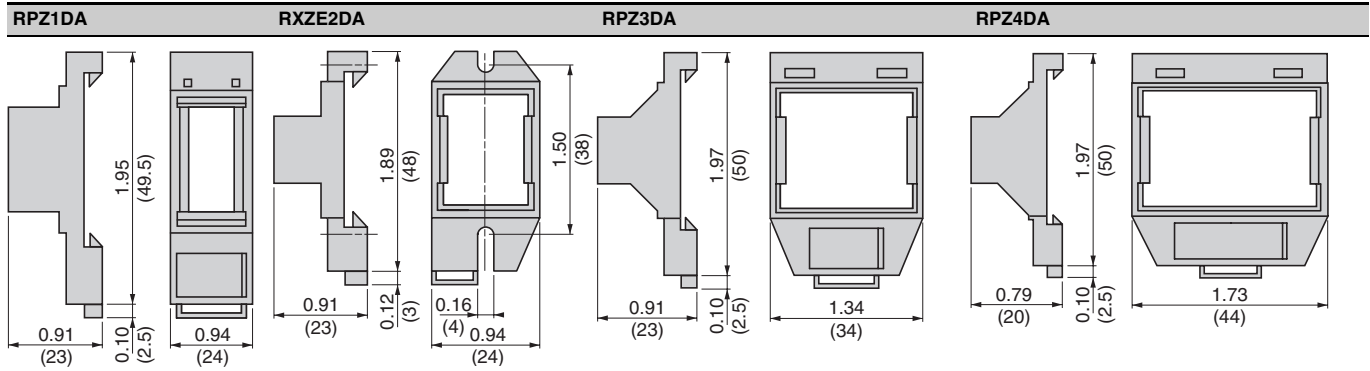

Mounting adapters for mounting directly to a panel

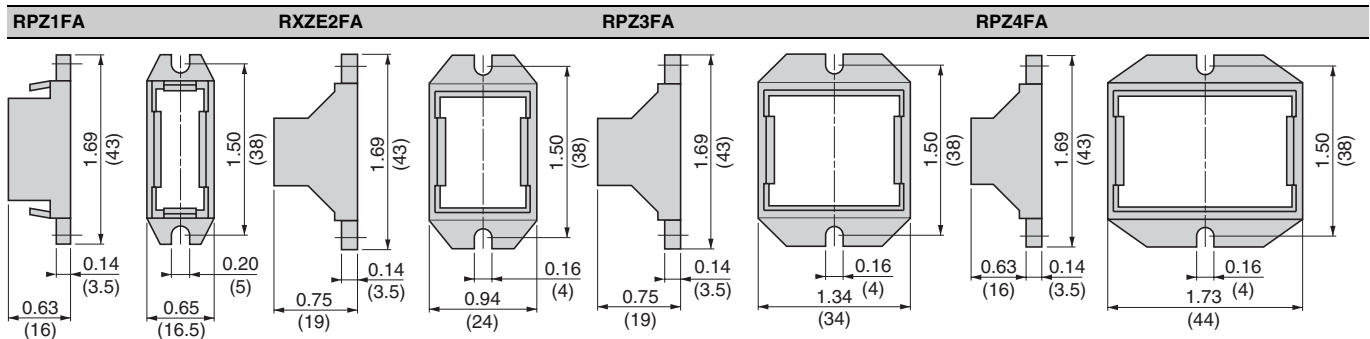

Mounting

Mounting adapters for DIN rail ¹

Mounting adapters for mounting directly to a panel

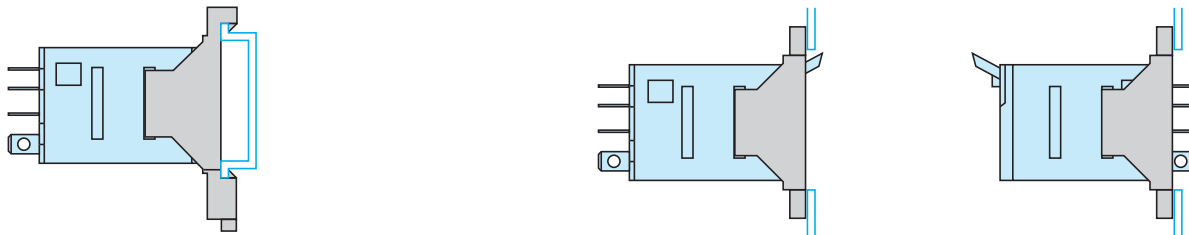

¹ Test button becomes inaccessible

Dimensions = $\frac{\text{Inches}}{\text{(mm)}}$

Power relays

RPM1●●●

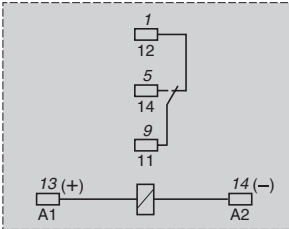
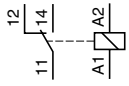

RPM2●●●

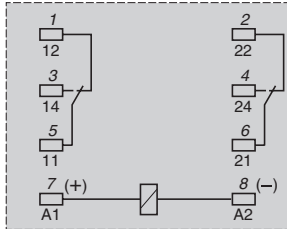
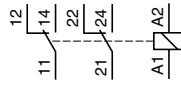

RPM3●●●

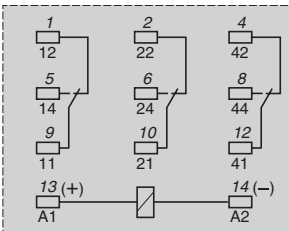
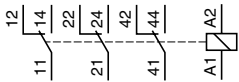

RPM4●●●

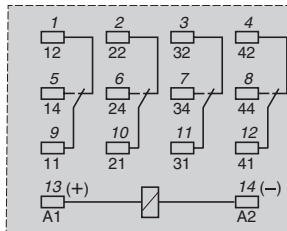
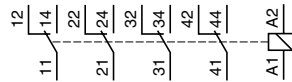

Numbers shown in *italics* correspond to NEMA marking. Viewed from pin end.

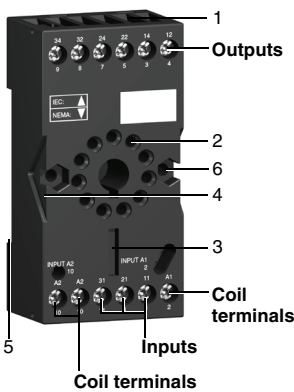
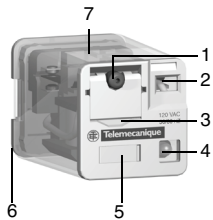
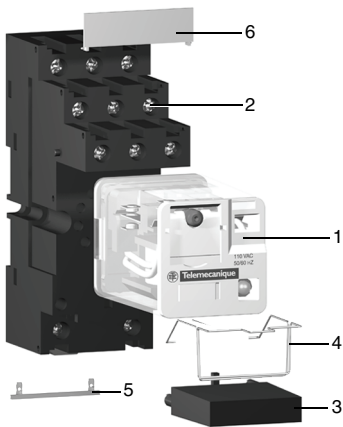

Product Description

The RUM universal relay range consists of:

1. 10 A relays with DPDT and 3PDT contacts, with cylindrical or flat pins, and 3 A “low level” relays with 3PDT contacts, with cylindrical pins. All these relays have the same dimensions.
2. Sockets with mixed or separate contact terminals.
3. Protection modules (diode, RC circuit, or varistor) or 1 timer module. All these modules are common to all sockets.
4. A metal hold-down clip for all sockets.
5. A 2-pole bus jumper that can be used on sockets with separate contact terminals to simplify cabling when creating a jumper between the coil terminals.
6. Clip-in markers for the sockets.

Relay Description

1. Spring return push button for testing the contacts (green: DC, red: AC).
2. Mechanical “relay status” indicator.
3. Optional removable lock-down door and push button, enabling forced maintaining of the contacts for test or maintenance purposes. During operation, this lock-down door must always be in the closed position.
4. Bipolar LED (depending on version) indicating the relay status.
5. Removable marker for relay identification.
6. Eight or eleven cylindrical or flat pins.
7. Area by which the product can be easily gripped.

Socket Description

Sockets with mixed contact terminals

1. Box lug connectors.
2. Eight or eleven female contacts for the relay cylindrical pins.
3. Location for protection modules or the timer module.
4. Locking component for metal hold-down clip.
5. Locating slot for DIN rail mounting.
6. Two mounting holes for panel mounting.

NOTE: The inputs are mixed with the relay coil terminals, with the outputs being located on the opposite side of the socket.

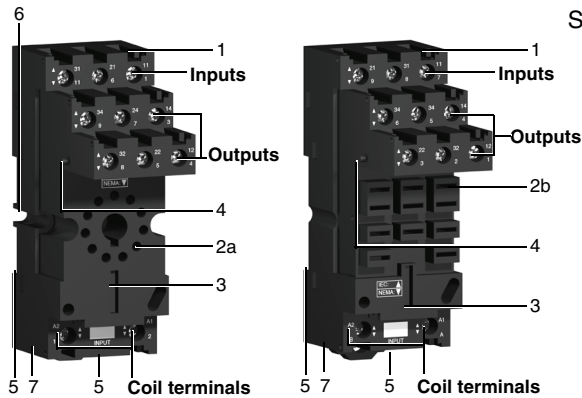

Sockets with separate contact terminals

1. Box lug connectors.
2. a. Eight or eleven female contacts for the relay cylindrical pins.
b. Eleven female contacts for the relay flat pins.
3. Location for protection modules or the timer module.
4. Locking component for metal hold-down clip.
5. Locating slot for mounting on DIN rail.
6. Two mounting holes for panel mounting.
7. Location for bus jumpers (see mounting on sockets on page 28).

NOTE: The inputs and outputs are separated from the relay coil terminals.

General characteristics

Conforming to standards		IEC/EN 61810-1 (iss. 2), UL 508, CSA C22-2 n° 14
Product certifications		cULus File E164862 CCN NLDX, NLDX7; cURus File E164862 CCN NLDX2, NLDX8; CSA pending; CE; RoHS compliant
Ambient air temperature around the device	Storage	-40–185 °F (-40–85 °C)
	Operation	-40–131 °F (-40–55 °C)
Vibration resistance	Conforming to IEC/EN 60068-2-6	4 gn (10–50 Hz)
Degree of protection	Conforming to IEC/EN 60529	IP 40
Shock resistance conforming to IEC/EN 60068-2-27	Opening	10 gn
	Closing	5 gn
Protection category (see page 38)		RT I
Mounting position		Any

Insulation characteristics

Rated insulation voltage (Ui)		250 V (IEC), 300 V (UL, CSA)
Rated impulse withstand voltage (Uimp)		3.6 kV (1.2/50 µs)
Dielectric strength (rms voltage)	Between coil and contact	2,500 Vac
	Between poles	2,500 Vac
	Between contacts	1,500 Vac

Contact characteristics

Relay type		RUMF2●●●	RUMF3B●●●	RUMC2●●●	RUMC3A●●●
Number and type of contacts (see page 28)		DPDT	3PDT	DPDT	3PDT
Contact materials		AgNi			
Conventional thermal current (Ith)	For ambient temperature ≤ 131 °F (55 °C)	10 A			
	Conforming to IEC in utilization category AC-1	N.O.	10 A	N.C.	5 A
Rated operational current	Conforming to UL Resistive @277 Vac, hp @ 120 Vac	16 A, 1/3 hp			
	No load	36,000			
Maximum operating rate In operating cycles/hour	Under load	3,600			
	Maximum	250 Vac/Vdc			
Switching voltage	Minimum	10 mA on 17 V			
	Maximum	2,500 VA			
Utilization coefficient		20%			
Mechanical durability in millions of operating cycles		5			
Electrical durability in millions of operating cycles	Resistive load	0.1			

Electrical durability of contacts

Resistive load AC

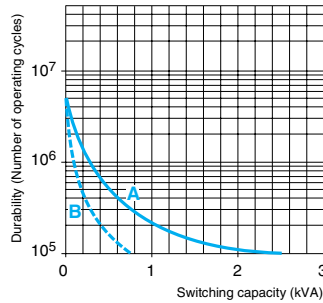

A=RUMF●●●●●, RUMC2●●●, RUMC3A●●●, B=RUMC3G●●●

Coil characteristics

Average consumption	AC	2-3 VA									
	DC	1.4 W									
Drop-out voltage threshold	AC	≥ 0.15 U _c									
	DC	≥ 0.1 U _c									
Operating time (response time)	Between coil energization and making of the N.O. contact	AC	20 ms								
		DC	20 ms								
	Between coil de-energization and making of the N.C. contact	AC	20 ms								
		DC	20 ms								
Coil voltage U _c		12 V	24 V	48 V	60 V	110 V	120 V	125 V	220 V	230 V	
Relay coil voltage codes		JD	BD	ED	ND	FD	—	GD	MD	—	
DC	Average resistance at 68 °F (20 °C) ± 10%	120 Ω	470 Ω	1,800 Ω	2,790 Ω	10,000 Ω	—	10,000 Ω	3,700 Ω	—	
	Operating voltage limits	Min.	9.6 V	19.2 V	38.4 V	48 V	88 V	—	100 V	176 V	—
		Max.	13.2 V	26.4 V	52.8 V	66 V	121 V	—	138 V	242 V	—
Relay coil voltage codes		—	B7	E7	—	—	F7	—	—	P7	
AC	Average resistance at 68 °F (20 °C) ± 15%	—	72 Ω	290 Ω	—	—	1,700 Ω	—	—	7,200 Ω	
	Operating voltage limits	Min.	—	19.2 V	38.4 V	—	—	96 V	—	—	184 V
		Max.	—	26.4 V	52.8 V	—	—	132 V	—	—	253 V

Socket characteristics

Socket type		RUZC2M	RUZC3M	RUZSC2M	RUZSC3M	RUZSF3M
Relay types used		RUMC2●●●●●	RUMC3●●●●●	RUMC2●●●●●	RUMC3●●●●●	RUMF●●●●●
Product certifications		cURus File E172326 CCN SWIV2, SWIV8; CSA (pending); CE; RoHS compliant				
Conventional thermal current (I _{th})		12 A				
Degree of protection	Conforming to IEC/EN 60529	IP 20				
Connection	Solid wire without cable end	1 conductor: AWG 20-12 (0.5-2.5 mm ²) 2 conductors: AWG 20-14 (0.5-1.5 mm ²)				
	Flexible wire with cable end	1 conductor: AWG 24-14 (0.2-2.5 mm ²) 2 conductors: AWG 24-16 (0.2-1.5 mm ²)				
	Flexible wire without cable end	1 conductor: AWG 24-14 (0.2-2.5 mm ²) 2 conductors: AWG 24-16 (0.2-1.5 mm ²)				
Maximum tightening torque		5.3 lbf-in (0.6 N•m) (M3 screw)				
Contact terminal arrangement		Mixed				Separate
Bus jumper I _{th} : 5 A		No				Yes

Relays for standard applications with lockable test button, without LED (sold in lots of 10)

		Number and type of contacts - Thermal current (Ith)					
		DPDT - 10 A				3PDT - 10 A	
Pins	Coil Voltage	Catalog Number	Weight		Catalog Number	Weight	
			lb.	kg		lb.	kg
Cylindrical	12 Vdc	RUMC2AB1JD	0.186	0.084	RUMC3AB1JD	0.194	0.088
	24 Vdc	RUMC2AB1BD	0.186	0.084	RUMC3AB1BD	0.194	0.088
	48 Vdc	RUMC2AB1ED	0.186	0.084	RUMC3AB1ED	0.194	0.088
	60 Vdc	—	—	—	RUMC3AB1ND	0.194	0.088
	110 Vdc	RUMC2AB1FD	0.186	0.084	RUMC3AB1FD	0.194	0.088
	125 Vdc	—	—	—	RUMC3AB1GD	0.194	0.088
	220 Vdc	—	—	—	RUMC3AB1MD	0.194	0.088
	24 Vac	RUMC2AB1B7	0.186	0.084	RUMC3AB1B7	0.194	0.088
	48 Vac	RUMC2AB1E7	0.186	0.084	RUMC3AB1E7	0.194	0.088
	120 Vac	RUMC2AB1F7	0.186	0.084	RUMC3AB1F7	0.194	0.088
Flat	230 Vac	RUMC2AB1P7	0.186	0.084	RUMC3AB1P7	0.194	0.088
	12 Vdc	RUMF2AB1JD	0.177	0.080	RUMF3AB1JD	0.186	0.084
	24 Vdc	RUMF2AB1BD	0.177	0.080	RUMF3AB1BD	0.186	0.084
	48 Vdc	RUMF2AB1ED	0.177	0.080	RUMF3AB1ED	0.186	0.084
	110 Vdc	RUMF2AB1FD	0.177	0.080	RUMF3AB1FD	0.186	0.084
	24 Vac	RUMF2AB1B7	0.177	0.080	RUMF3AB1B7	0.186	0.084
	48 Vac	RUMF2AB1E7	0.177	0.080	RUMF3AB1E7	0.186	0.084
	120 Vac	RUMF2AB1F7	0.177	0.080	RUMF3AB1F7	0.186	0.084
	230 Vac	RUMF2AB1P7	0.177	0.080	RUMF3AB1P7	0.186	0.084

Relays for standard applications with lockable test button, with LED (sold in lots of 10)

Cylindrical	12 Vdc	RUMC2AB2JD	0.186	0.084	RUMC3AB2JD	0.194	0.088
	24 Vdc	RUMC2AB2BD	0.186	0.084	RUMC3AB2BD	0.194	0.088
	48 Vdc	RUMC2AB2ED	0.186	0.084	RUMC3AB2ED	0.194	0.088
	60 Vdc	—	—	—	RUMC3AB2ND	0.194	0.088
	110 Vdc	RUMC2AB2FD	0.186	0.084	RUMC3AB2FD	0.194	0.088
	125 Vdc	—	—	—	RUMC3AB2GD	0.194	0.088
	24 Vac	RUMC2AB2B7	0.186	0.084	RUMC3AB2B7	0.194	0.088
	48 Vac	RUMC2AB2E7	0.186	0.084	RUMC3AB2E7	0.194	0.088
	120 Vac	RUMC2AB2F7	0.186	0.084	RUMC3AB2F7	0.194	0.088
	230 Vac	RUMC2AB2P7	0.186	0.084	RUMC3AB2P7	0.194	0.088
Flat	12 Vdc	RUMF2AB2JD	0.186	0.084	RUMF3AB2JD	0.190	0.086
	24 Vdc	RUMF2AB2BD	0.186	0.084	RUMF3AB2BD	0.190	0.086
	48 Vdc	RUMF2AB2ED	0.186	0.084	RUMF3AB2ED	0.190	0.086
	110 Vdc	RUMF2AB2FD	0.186	0.084	RUMF3AB2FD	0.190	0.086
	24 Vac	RUMF2AB2B7	0.186	0.084	RUMF3AB2B7	0.190	0.086
	48 Vac	RUMF2AB2E7	0.186	0.084	RUMF3AB2E7	0.190	0.086
	120 Vac	RUMF2AB2F7	0.186	0.084	RUMF3AB2F7	0.190	0.086
	230 Vac	RUMF2AB2P7	0.186	0.084	RUMF3AB2P7	0.190	0.086



RUM●●AB2B7



RUM●●AB2F7



RUMC●AB3F7

Universal relays without lockable test button, with LED

Coil Voltage	Number and type of contacts - Thermal current (Ith)					
	DPDT - 10 A			3PDT - 10 A		
	Catalog Number	Weight		Catalog Number	Weight	
lb.		kg	lb.		kg	
With cylindrical pins (sold in lots of 10)						
12 Vdc	RUMC2AB3JD	0.186	0.084	RUMC3AB3JD	0.194	0.088
24 Vdc	RUMC2AB3BD	0.186	0.084	RUMC3AB3BD	0.194	0.088
48 Vdc	RUMC2AB3ED	0.186	0.084	RUMC3AB3ED	0.194	0.088
60 Vdc	—	—	—	RUMC3AB3ND	0.194	0.088
110 Vdc	RUMC2AB3FD	0.186	0.084	RUMC3AB3FD	0.194	0.088
125 Vdc	—	—	—	RUMC3AB3GD	0.194	0.088
24 Vac	RUMC2AB3B7	0.186	0.084	RUMC3AB3B7	0.194	0.088
48 Vac	RUMC2AB3E7	0.186	0.084	RUMC3AB3E7	0.194	0.088
120 Vac	RUMC2AB3F7	0.186	0.084	RUMC3AB3F7	0.194	0.088
230 Vac	RUMC2AB3P7	0.186	0.084	RUMC3AB3P7	0.194	0.088
With flat pins (sold in lots of 10)						
12 Vdc	RUMF2AB3JD	0.177	0.08	RUMF3AB3JD	0.186	0.084
24 Vdc	RUMF2AB3BD	0.177	0.08	RUMF3AB3BD	0.186	0.084
48 Vdc	RUMF2AB3ED	0.177	0.08	RUMF3AB3ED	0.186	0.084
110 Vdc	RUMF2AB3FD	0.177	0.08	RUMF3AB3FD	0.186	0.084
125 Vdc	—	—	—	RUMF3AB3GD	0.186	0.084
24 Vac	RUMF2AB3B7	0.177	0.08	RUMF3AB3B7	0.186	0.084
48 Vac	RUMF2AB3E7	0.177	0.08	RUMF3AB3E7	0.186	0.084
120 Vac	RUMF2AB3F7	0.177	0.08	RUMF3AB3F7	0.186	0.084
230 Vac	RUMF2AB3P7	0.177	0.08	RUMF3AB3P7	0.186	0.084

See page 26 for sockets and accessories.



RUZC3M +
relay RUMC3●●●●●

Sockets (sold in lots of 10)

Contact terminal arrangement	Connection	Relay type	Catalog Number	Weight	
				lb.	kg
Mixed	Box lug connector	RUMC2●●●●●	RUZC2M	0.12	0.054
		RUMC3●●●●●	RUZC3M	0.12	0.054
Separate		RUMC2●●●●●	RUZSC2M	0.21	0.095
		RUMC3●●●●●	RUZSC3M	0.22	0.100
		RUMF2●●●●●	RUZSF3M	0.21	0.095
		RUMF3●●●●●			



RUW241P7

Protection modules (sold in lots of 10)

Description	For use with	Voltage	Catalog Number	Weight	
				oz.	g
Diode	All sockets	6–250 Vdc	RUW240BD	0.14	4.0
RC circuit		110–240 Vac	RUW241P7	0.14	4.0
Varistor		24 Vac/Vdc	RUW242B7	0.14	4.0
		240 Vac/Vdc	RUW242P7	0.14	4.0



RUW101MW

Timer module

Description	For use with	Voltage	Catalog Number	Weight	
				oz.	g
Multifunction	All sockets	24–240 Vac/Vdc	RUW101MW	0.71	20.0

Timing relay

Description	For use with	Catalog Number
2 timed DPDT contacts (single-function or multi-function)	On sockets RUZ C●M	RE48A●● ¹

¹ Please refer to the *Zelio® Time - Timers* catalog (9050CT0001R2/05).



RUZC200



RUZS2

Accessories (sold in lots of 10)

Description	For use with	Catalog Number	Weight	
			oz.	g
Metal hold-down clip	All sockets	RUZC200	0.04	1.0
Bus jumper, 2-pole (Ith: 5 A)	All sockets with separate contacts	RUZS2	0.18	5.0
Clip-in markers	All relays (sheet of 108 markers)	RXZL520	2.82	80.0
	All sockets with separate contacts	RUZL420	0.04	1.0

Universal relays

RUMC●● RUMF●●

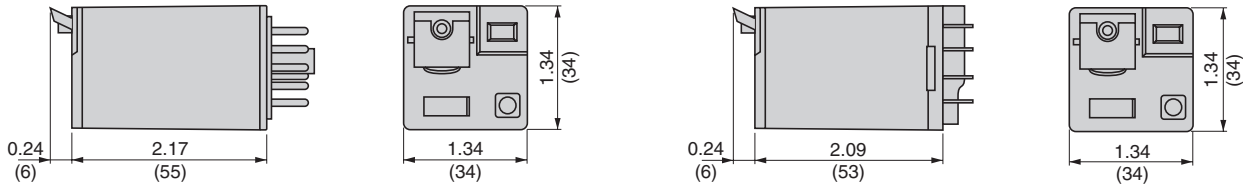

Sockets

Common side view RUZC2M RUZC3M

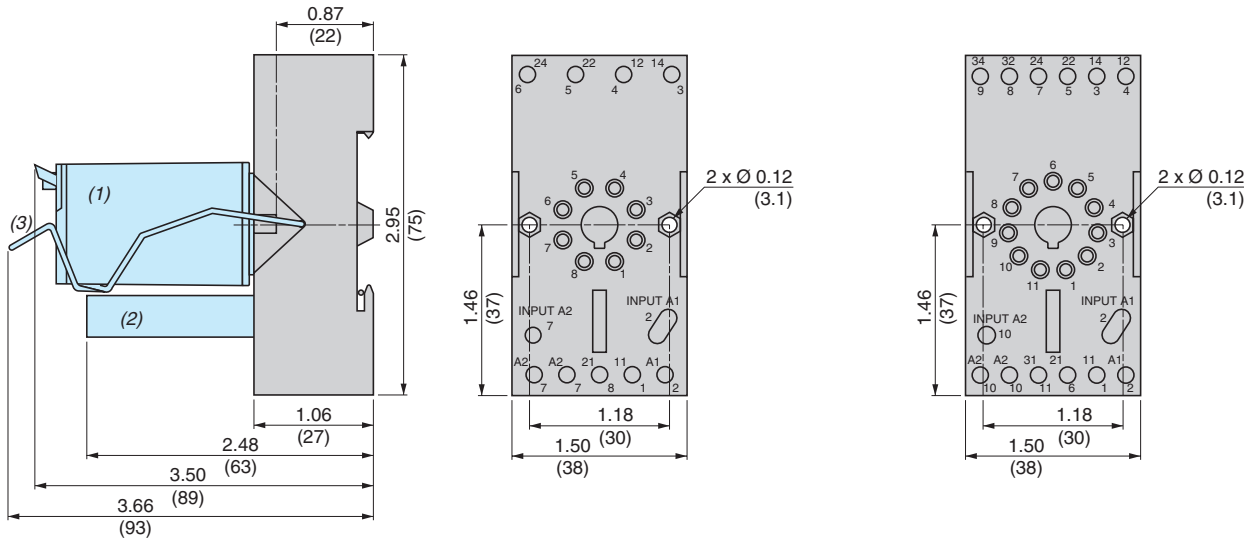

RUZSC2M RUZSC3M

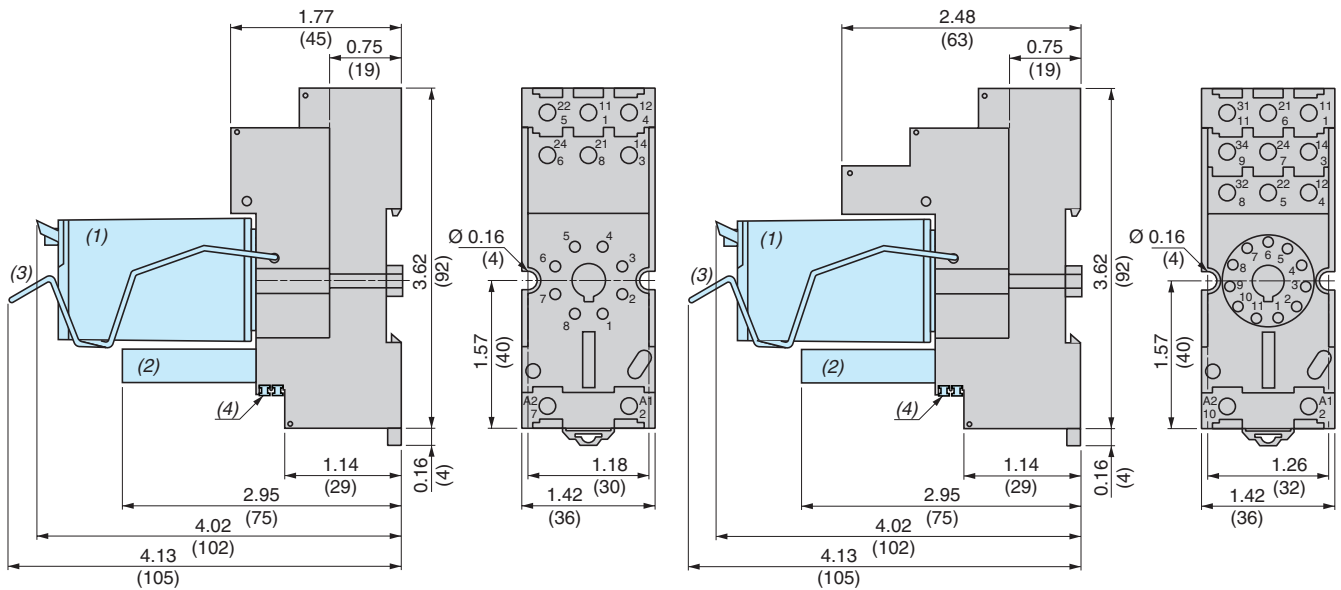

- (1) Relay
- (2) Protection module
- (3) Hold-down clip
- (4) 2 bus jumpers

Dimensions = Inches
(mm)

Sockets (continued)

RUZSF3M

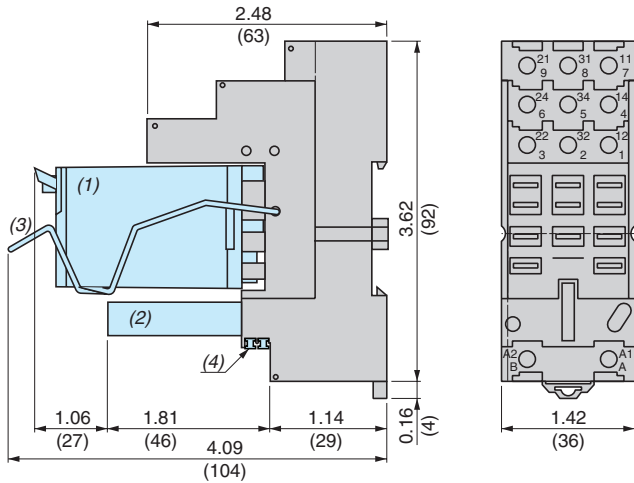

- (1) Relay
- (2) Protection module
- (3) Hold-down clip
- (4) 2 bus jumpers

Dimensions = Inches
(mm)

Metal hold-down clips and plastic markers

RUZC200

Mounting

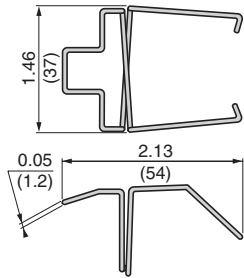

RUZL420

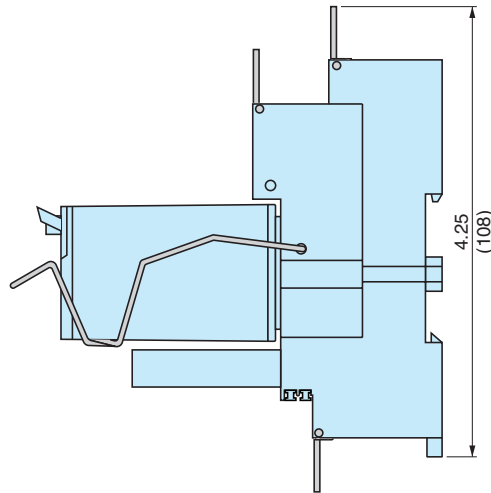
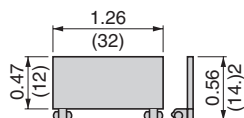

Bus jumper

RUZS2

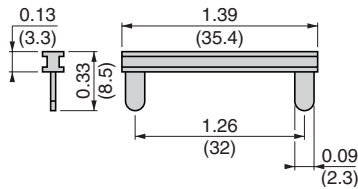

Mounting on sockets with separate contacts
 (view from below)

Example of bus jumper mounting on sockets

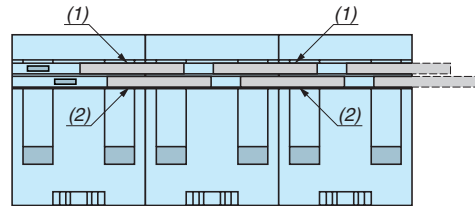

- (1) 2 bus jumpers (polarity A2)
- (2) 2 bus jumpers (polarity A1)

Wiring diagrams—universal relays

RUM•2AB•••

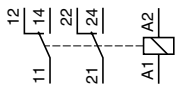

RUMC3•••••

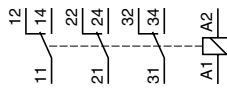

RUMF3AB•••

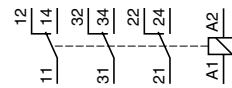

RUMC2AB•••

RUMF2AB•••

RUMC3•••••

RUMF3AB•••

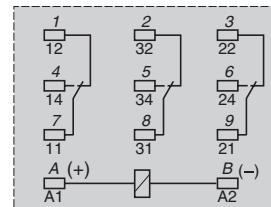
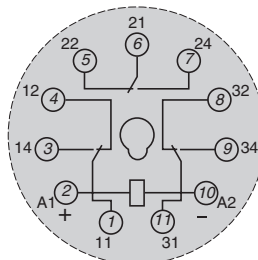
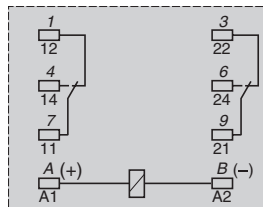
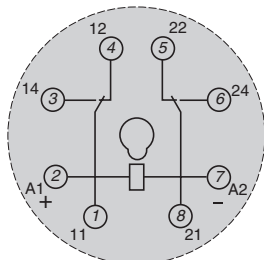

Numbers shown in *italics* correspond to NEMA marking. Viewed from pin end.

Multifunction timer module RUW101MW

Programming Timing range selection

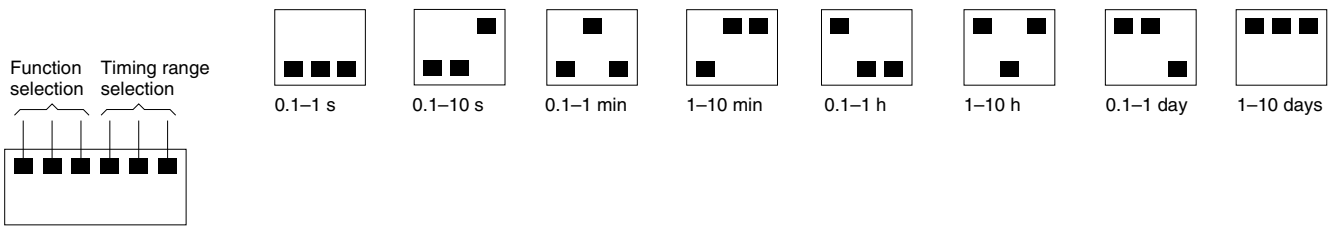

Function selection

Selection Function Control Function diagram Control scheme

	On-delay timer E	Series control		
	Interval timer Wu	Series control		
	Repeat cycle timer, starting On-delay Bi	Series control		
	Repeat cycle timer, starting Off-delay Bp	Series control		
	Off-delay timer R	Control by external contact (S)		
	One-shot timer Ws	Control by external contact (S)		
	Timing on de-energization Wa	Control by external contact (S)		
	On-delay timer Es	Control by external contact (S)		

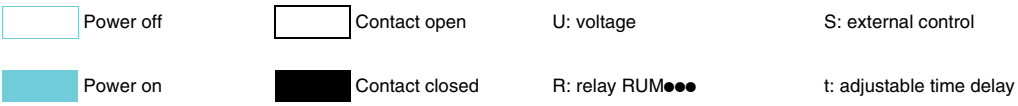

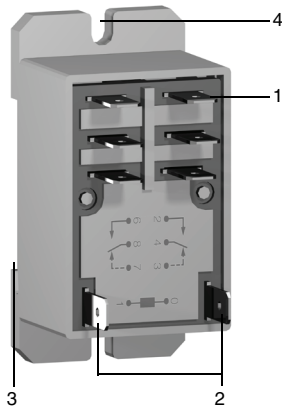

Product Description

RPF power relays with DPDT or 2 normally open (N.O.) DPST contacts consist of:

1. Four or six input/output, flat pins.
2. Two coil, flat pins.
3. A locating slot for mounting on DIN rail.
4. Two mounting holes for panel mounting.

General characteristics

Conforming to standards	IEC/EN 61810-1 (iss. 2), UL 508, CSA C22-2 n° 14	
Product certifications	cURus File E164862 CCN NLDX2, NLDX8; CSA pending; CE; RoHS compliant	
Ambient air temperature around the device	Storage	-40–185 °F (-40–85 °C)
	Operation	-40–131 °F (-40–55 °C)
Vibration resistance	Conforming to IEC/EN 60068-2-6	10 gn (10–55 Hz)
Degree of protection	Conforming to IEC/EN 60529	IP 40
Shock resistance conforming to IEC/EN 60068-2-27	Opening	10 gn
	Closing	10 gn
Protection category (see page 38)	RT IV	
Mounting position	Any	

Insulation characteristics

Rated insulation voltage (Ui)	Conforming to IEC/EN 60947	250 V
Rated impulse withstand voltage (Uimp)	3.6 kV (1.2/50 μs)	
Dielectric strength (rms voltage)	Between coil and contact	2,500 Vac
	Between poles	2,500 Vac
	Between contacts	1,500 Vac

Contact characteristics

Relay type		RPF2A●●	RPF2B●●
Number and type of contacts (see page 32)		DPST (N.O.)	DPDT
Contact materials		AgSnO ₂	
Conventional thermal current (I _{th})	For ambient temperature ≤ 104 °F (40 °C)	30 A (when mounted with 13mm gap between two relays) 25 A (when mounted side by side without a gap)	
Rated operational current	Conforming to IEC in utilization category AC-1	N.O.	30 A
		N.C.	3 A
	Conforming to UL (resistive@277 Vac)		30 A
Maximum operating rate In operating cycles/hour	No load	18,000	
	Under load	1,200	
Switching voltage	Maximum	250 Vac/Vdc	
	Minimum	10 mA on 17 Vdc	
Switching capacity	Minimum	10 mA on 17 Vdc	
	Maximum	7,200 VA	
Utilization coefficient		10%	
Mechanical durability in millions of operating cycles		5	
Electrical durability in millions of operating cycles	Resistive load	0.05 (N.O. contact only)	

Electrical durability of contacts

Resistive load AC

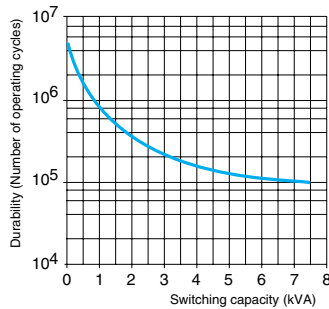

A=RPF2●●● (30 A) B=RPF2●●● (25 A)

Coil characteristics

Average consumption		AC	4 VA				
		DC	1.7 W				
Drop-out voltage threshold		AC	≥ 0.15 U _c				
		DC	≥ 0.1 U _c				
Operating time (response time)	Between coil energization and making of the N.O. contact	AC	20 ms				
		DC	20 ms				
	Between coil de-energization and making of the N.C. contact	AC	20 ms				
		DC	20 ms				
Coil voltage U _c			12 V	24 V	110 V	120 V	230 V
Relay coil voltage codes			JD	BD	FD	—	—
DC	Average resistance at 68 °F (20 °C) ± 10%		86 Ω	350 Ω	7,255 Ω	—	—
	Operating voltage limits	Min.	9.6 V	19.2 V	88 V	—	—
		Max.	13.2 V	26.4 V	121 V	—	—
Relay coil voltage codes			—	B7	—	F7	P7
AC	Average resistance at 68 °F (20 °C) ± 15%		—	250 Ω	—	1,600 Ω	6,500 Ω
	Operating voltage limits	Min.	—	19.2 V	—	96 V	184 V
		Max.	—	26.4 V	—	132 V	253 V

Zelio® Plug-in Relays

Ordering Information, Dimensions, and Wiring Diagrams

RPF Power Relays



RPF2B●●

Power relays (sold in lots of 10)

Coil Voltage	Number and type of contacts - Thermal current (Ith)					
	DPST (N.O.) - 30 A ¹			DPDT - 30 A ¹		
	Catalog Number	Weight		Catalog Number	Weight	
lb.		kg	lb.		kg	
12 Vdc	RPF2AJD	0.19	0.086	RPF2BJD	0.19	0.086
24 Vdc	RPF2ABD	0.19	0.086	RPF2BBD	0.19	0.086
110 Vdc	RPF2AFD	0.19	0.086	RPF2BFD	0.19	0.086
24 Vac	RPF2AB7	0.19	0.086	RPF2BB7	0.19	0.086
120 Vac	RPF2AF7	0.19	0.086	RPF2BF7	0.19	0.086
230 Vac	RPF2AP7	0.19	0.086	RPF2BP7	0.19	0.086

¹ 30 A when mounted with 13 mm gap between two relays
25 A when mounted side by side without a gap.

Dimensions

RPF2A●●, RPF2B●●

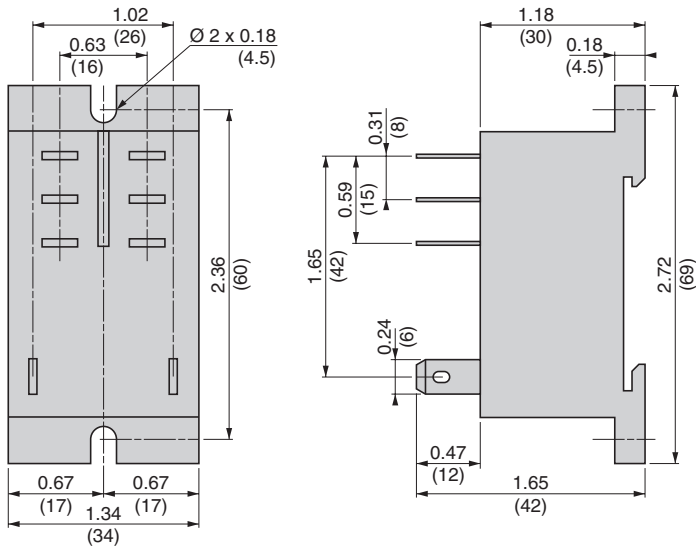

Dimensions = $\frac{\text{Inches}}{\text{(mm)}}$

Wiring diagrams

RPF2A●●

RPF2B●●

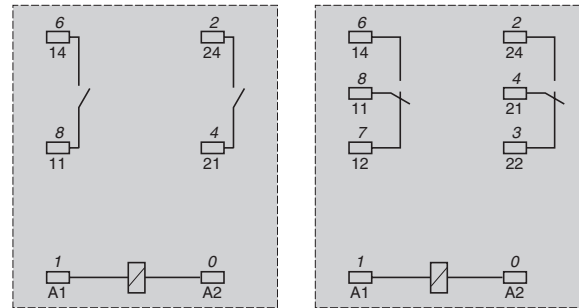

Numbers shown in italics correspond to NEMA marking. Viewed from pin end.

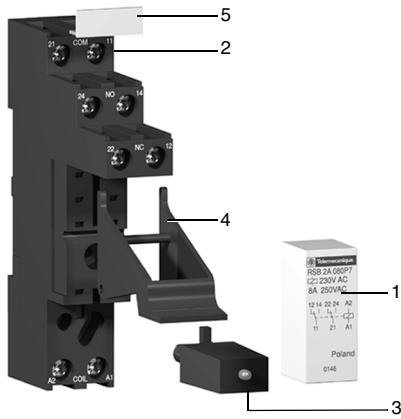

Product Description

The RSB interface relay range consists of:

1. 12 A relays with SPDT contact, 16 A relays with SPDT contact, and 8 A relays with DPDT contacts.
2. Sockets with separate contact terminals.
3. Protection modules (diode, diode + LED, RC circuit, or varistor + LED). All these modules are common to all sockets.
4. A plastic hold-down clip for all sockets.
5. Clip-in markers for the sockets.

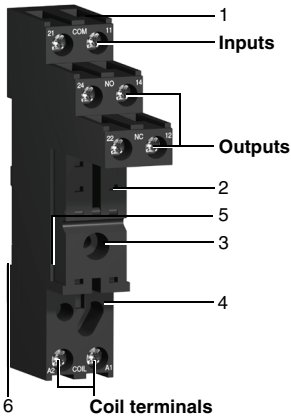

Socket Description

Sockets with Separate Contact Terminals

1. Box lug connectors.
2. Five or eight female contacts for the relay pins.
3. A mounting hole for panel mounting.
4. Location for protection modules.
5. Locking components for plastic hold-down clip.
6. Locating slot for mounting on DIN rail.

NOTE: The inputs and outputs are separate from the coil terminals.

General characteristics

Conforming to standards	IEC/EN 61810-1 (iss. 2), UL 508, CSA C22-2 n° 14	
Product certifications	cURus File E173076 CNN NRNT2, NRNT8; CSA File 215736 Class 321107; CE; RoHS compliant	
Ambient air temperature around the device	Storage	-40–185 °F (-40–85 °C)
	Operation	Vdc: -40–185 °F (-40–85 °C); Vac: -40–158 °F (-40–70 °C)
Vibration resistance	Conforming to IEC/EN 60068-2-6	> 10 gn (10–150 Hz)
Degree of protection	Conforming to IEC/EN 60529	IP 40
Shock resistance conforming to IEC/EN 60068-2-27	Opening	5 gn
	Closing	10 gn
Protection category (see page 38)	RT I	
Mounting position	Any	

Insulation characteristics

Rated insulation voltage (Ui)	Conforming to IEC/EN 60947	400 V
Rated impulse withstand voltage (Uimp)		3.6 kV (1.2/50 μs)
Dielectric strength (rms voltage)	Between coil and contact	5,000 Vac
	Between poles	2,500 Vac
	Between contacts	1,000 Vac

Contact characteristics

Relay type		RSB1A120●●	RSB1A160●●	RSB2A080●●
Number and type of contacts (see page 37)		SPDT	SPDT	DPDT
Contact materials		AgNi		
Conventional thermal current (Ith)	For ambient temperature ≤ 104 °F (40 °C)	12 A	16 A	8 A
Rated operational current	Conforming to IEC in utilization categories AC-1 and DC-1	N.O.	16 A	8 A
		N.C.	6 A	4 A
Maximum operating rate In operating cycles/hour	No load	72,000		
	Under load	600		
Switching voltage	Maximum	400 Vac, 300 Vdc		
Switching capacity	Minimum	5 mA at 60 V		
	Maximum	3,000 VA	4,000 VA	2,000 VA
Mechanical durability in millions of operating cycles		≥ 30		
Electrical durability in millions of operating cycles	Resistive load	12 A, 250 V: ≥ 0.1	16 A, 250 V: ≥ 0.07	8 A, 250 V: ≥ 0.1
	Inductive load	See curves below		

Electrical durability of contacts

Resistive load AC

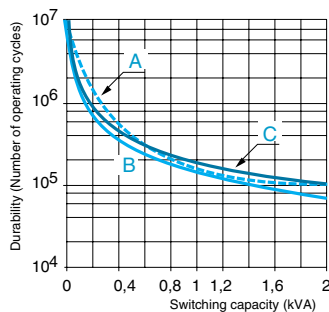

Reduction coefficient for inductive load AC (depending on power factor cos φ)

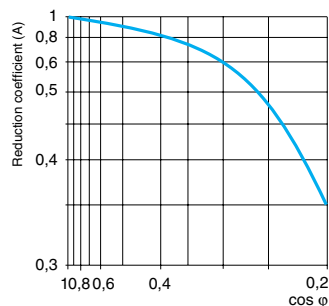

Maximum switching capacity on resistive load DC

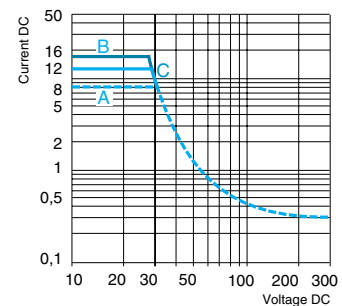

A=RSB2A080●● B=RSB1A160●● C=RSB1A120●●

Durability (inductive load) = durability (resistive load) x reduction coefficient.

Coil characteristics

Average consumption	AC	0.75 VA											
	DC	0.45 W											
Drop-out voltage threshold	AC	≥ 0.15 U _c											
	DC	≥ 0.1 U _c											
Operating time (response time)	Between coil energization and making of the N.O. contact	AC	12 ms										
		DC	9 ms										
	Between coil de-energization and making of the N.C. contact	AC	10 ms										
		DC	4 ms										
Coil voltage U_c		6 V	12 V	24 V	48 V	60 V	110 V	120 V	220 V	230 V	240 V		
Relay coil voltage codes		RD	JD	BD	ED	ND	FD	—	—	—	—		
DC	Average resistance at 68 °F (20 °C) ± 10%		90 Ω	360 Ω	1,440 Ω	5,700 Ω	7,500 Ω	25,200 Ω	—	—	—	—	
	Operating voltage limits	Min.	4.8 V	9.6 V	19.2 V	38.4 V	48 V	88 V	—	—	—	—	
		Max.	6.6 V	13.2 V	26.4 V	52.8 V	68 V	121 V	—	—	—	—	
Relay coil voltage codes		—	—	B7	E7	—	—	F7	M7	P7	U7		
AC	Average resistance at 68 °F (20 °C) ± 15%		—	—	400 Ω	1,500 Ω	—	—	10,200 Ω	35,500 Ω	38,500 Ω	42,500 Ω	
	Operating voltage limits	Min.	50 Hz	—	—	19.2 V	38.4 V	—	—	96 V	176 V	184 V	192 V
			60 Hz	—	—	20.4 V	40.8 V	—	—	102 V	187 V	195.5 V	204 V
		Max.	50/60 Hz	—	—	26.4 V	57.6 V	—	—	144 V	264 V	276 V	268 V

Socket characteristics

Socket type		RSZE1S35M	RSZE1S48M
Relay types used		RSB1A120●●	RSB2A080●● RSB1A160●● ¹
Product certifications		cURus File E172326 CCN SWIV2; CSA File 212916 Class 3211 07; CE; RoHS compliant	
Conventional thermal current (I_{th})		12 A	
Degree of protection	Conforming to IEC/EN 60529	IP 20	
Connection	Solid wire without cable end	1 conductor: AWG 20–12 (0.5–2.5 mm ²) 2 conductors: AWG 20–14 (0.5–1.5 mm ²)	
	Flexible wire with cable end	1 conductor: AWG 24–14 (0.2–2.5 mm ²) 2 conductors: AWG 24–16 (0.2–1.5 mm ²)	
	Flexible wire without cable end	1 conductor: AWG 24–14 (0.2–2.5 mm ²) 2 conductors: AWG 24–16 (0.2–1.5 mm ²)	
Maximum tightening torque		5.3 lbf-in (0.6 N•m) (M3 screw)	
Contact terminal arrangement		Separate	

¹ When using the relay with socket RSZ E1S48M, terminals must be jumpered. See wiring diagrams on page 37.

See page 36 for sockets and accessories.



RSB1A120JD
+ RZM031FPD
+ RSZE1S35M



RSB1A160BD
+ RSZE1S48M



RSB2A080BD
+ RSZE1S48M

Relays for standard applications (sold in lots of 10)

Coil Voltage	Number and type of contacts - Thermal current (Ith)			Weight lb. kg	
	SPDT - 12 A	SPDT - 16 A	DPDT - 8 A		
	Catalog Number ¹	Catalog Number ¹	Catalog Number ¹		
6 Vdc	RSB1A120RD	RSB1A160RD	RSB2A080RD	0.03	0.014
12 Vdc	RSB1A120JD	RSB1A160JD	RSB2A080JD	0.03	0.014
24 Vdc	RSB1A120BD	RSB1A160BD	RSB2A080BD	0.03	0.014
48 Vdc	RSB1A120ED	RSB1A160ED	RSB2A080ED	0.03	0.014
60 Vdc	RSB1A120ND	RSB1A160ND	RSB2A080ND	0.03	0.014
110 Vdc	RSB1A120FD	RSB1A160FD	RSB2A080FD	0.03	0.014
24 Vac	RSB1A120B7	RSB1A160B7	RSB2A080B7	0.03	0.014
48 Vac	RSB1A120E7	RSB1A160E7	RSB2A080E7	0.03	0.014
120 Vac	RSB1A120F7	RSB1A160F7	RSB2A080F7	0.03	0.014
220 Vac	RSB1A120M7	RSB1A160M7	RSB2A080M7	0.03	0.014
230 Vac	RSB1A120P7	RSB1A160P7	RSB2A080P7	0.03	0.014
240 Vac	RSB1A120U7	RSB1A160U7	RSB2A080U7	0.03	0.014

¹ To order a relay complete with socket (sold in lots of 20): add suffix S to the references selected above.
Example: RSB2A080RD + RSZ E1S48M becomes RSB2A080RDS.

Sockets - 12 A, 300 Vac (sold in lots of 10)

Contact terminal arrangement	Connection	Relay type	Catalog Number	Weight	
				lb.	kg
Separate	Box lug connector	RSB1A120●●	RSZE1S35M	0.13	0.060
		RSB1A160●● ²	RSZE1S48M	0.11	0.050
		RSB2A080●●			

² When using the relay with socket RSZ E1S48M, terminals must be jumpered. See wiring diagrams on page 37.

Protection modules (sold in lots of 10)

Description	For use with	Voltage	Catalog Number	Weight	
				oz.	g
Diode	All sockets	6–230 Vdc	RZM040W	0.11	3.0
RC circuit	All sockets	24–60 Vac	RZM041BN7	0.35	10.0
		110–240 Vac	RZM041FU7	0.35	10.0
Diode + green LED	All sockets	6–24 Vdc	RZM031RB	0.14	4.0
		24–60 Vdc	RZM031BN	0.14	4.0
		110–230 Vdc	RZM031FPD	0.14	4.0
Varistor + green LED	All sockets	6–24 Vac/Vdc	RZM021RB	0.18	5.0
		24–60 Vac/Vdc	RZM021BN	0.18	5.0
		110–230 Vac/Vdc	RZM021FP	0.18	5.0

Accessories (sold in lots of 10)

Description	For use with	Catalog Number	Weight	
			oz.	g
Plastic hold-down clip	All sockets	RSZR215	0.07	2.0
Marker	All sockets	RSZL300	0.04	1.0

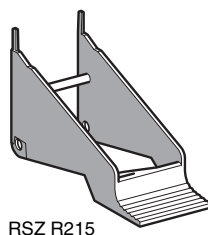

RSZ R215

Dimensions

Interface relays

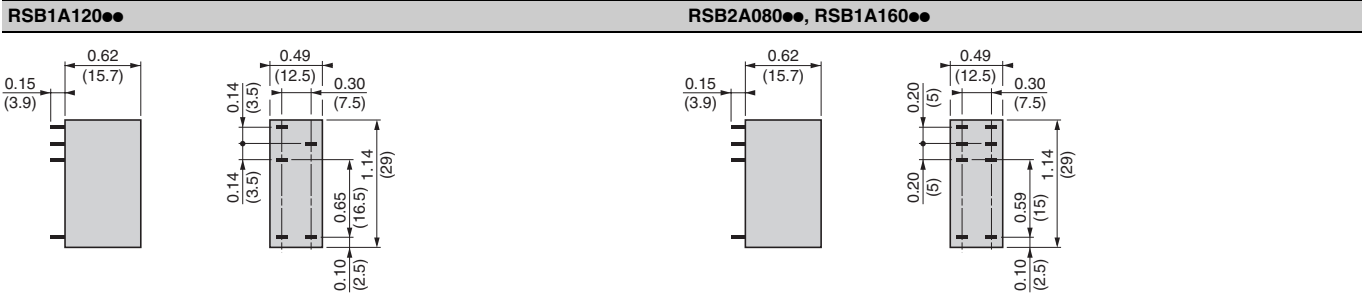

Sockets

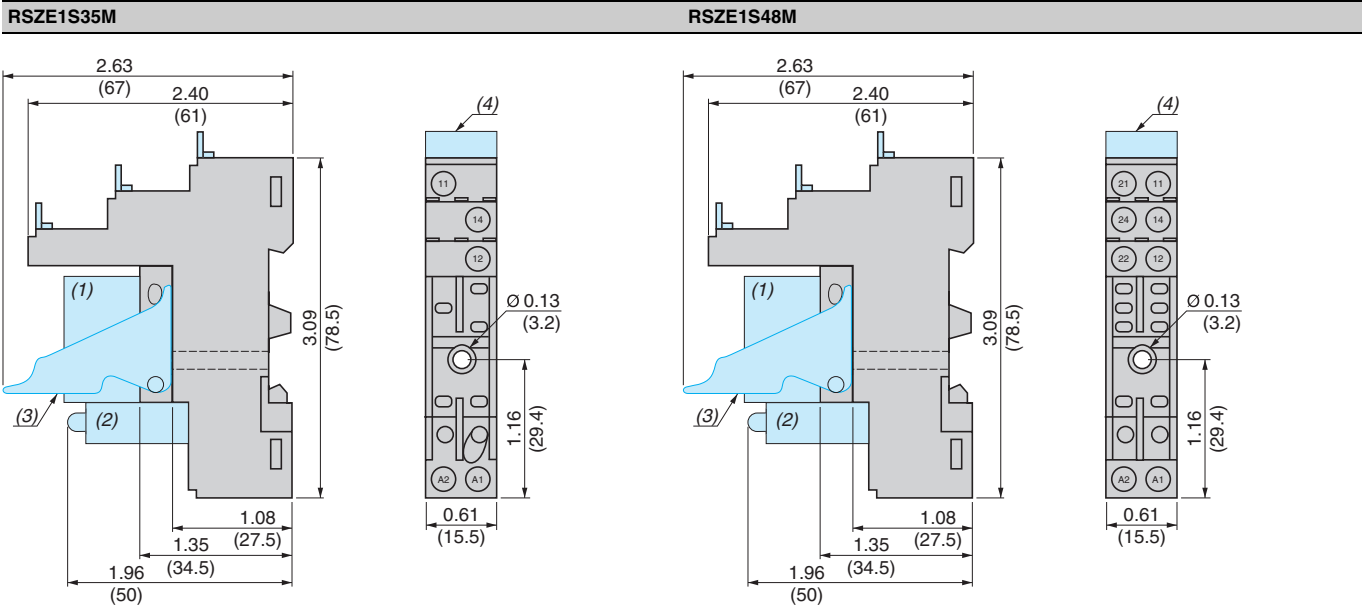

Wiring diagrams

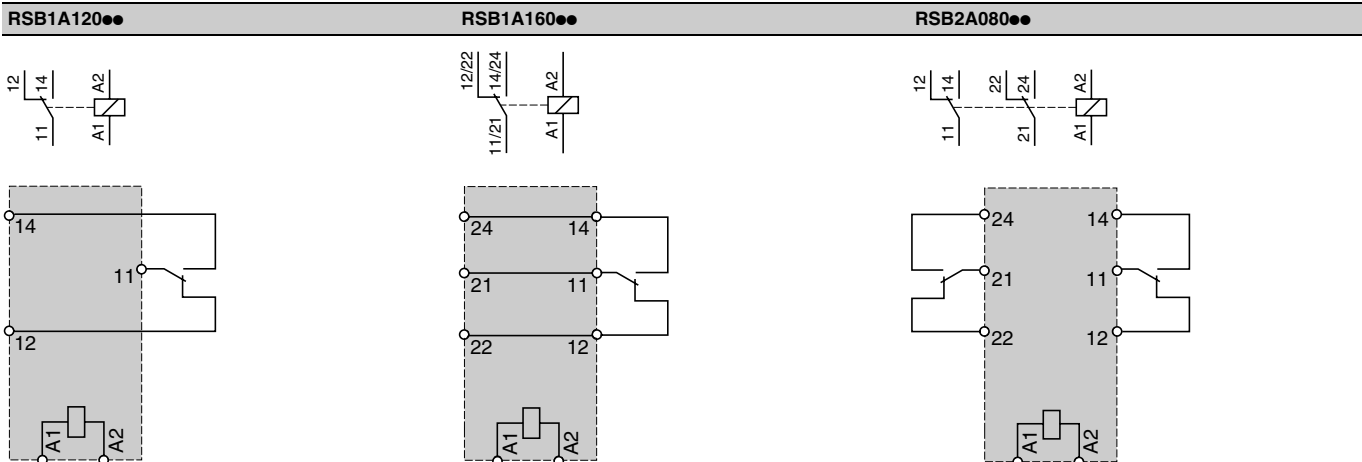

Interface relays



When using relay RSB 1A160●● with socket RSZE1S48M, terminals 11 and 21, 14 and 24, and 12 and 22 must be jumpered.

Relays

Contact types

Symbol	Configuration	USA	EU
	Make contact (Normally Open)	SPST-N.O. DPST-N.O. nPST-N.O. ¹	N.O.
	Break contact (Normally Closed)	SPST-N.C. DPST-N.C. nPST-N.C. ¹	N.C.
	Changeover Contact (Form C)	SPDT DPDT nPDT ¹	C/O

¹ n = number of contacts.

Utilization categories

Category	Type of current	Applications
AC-1	AC single-phase AC 3-phase	Resistive or slightly inductive loads.
AC-3	AC 3-phase	Starting and braking of squirrel cage motors; reversing direction of rotation only after stopping of motor.
AC-4	AC 3-phase	Starting of squirrel cage motors, inching. Plugging, reversing direction of rotation.
DC-1	DC	Resistive or slightly inductive loads. ²
AC-14	AC single-phase	Control of electromagnetic loads (< 72 VA), auxiliary control relays, power contactors, electromagnetic solenoid valves and electromagnets.
AC-15	AC single-phase	Control of electromagnetic loads (> 72 VA), auxiliary control relays, power contactors, electromagnetic solenoid valves and electromagnets.
DC-13	DC	Control of electromagnetic loads, auxiliary control relays, power contactors, magnetic solenoid valves and electromagnets.

² The switchable voltage can be doubled, for an equal current, by connecting two contacts in series.

Protection categories

Category	Explanation	Condition
RT 0	Unenclosed relay	Relay not provided with a protective case.
RT I	Dust protected relay	Relay provided with a case which protects its mechanism from dust.
RT II	Flux-proof relay	Relay capable of being automatically soldered without allowing the migration of solder fluxes beyond the intended areas.
RT III	Wash-tight relay	Relay capable of being automatically soldered and then washed to remove flux residues without risk of ingress of flux or washing solvents.
RT IV	Sealed relay	Relay provided with a case which has no venting to the outside atmosphere.
RT V	Hermetically sealed relay	Sealed relay having an enhanced level of sealing.

Protection Modules

Whenever an inductive load is de-energized (coil of a relay or of a contactor), an overvoltage appears at its terminals. This voltage peak can reach several thousand volts and a frequency of several MHz. It is likely to disturb the operation of automation systems which contain electronic devices.

Protection modules are used to reduce the voltage peak on de-energization and, therefore, limit the energy of interference signals to a level that will not disturb surrounding coils and electronic devices. They are used to avoid:

- electromagnetic compatibility problems
- the deterioration of contact materials
- the destruction of insulation due to overvoltage
- the destruction of electronic components

Diode Protection Module (with or without LED)

- Advantages
 - accumulation of energy allowing current flow in the same direction
 - absence of any voltage peaks at the coil terminals
 - low cost
- Disadvantages
 - increase in relay drop-out time (3 to 4 times the usual time)
 - no polarity protection

Protection Module with Varistor

- Advantages
 - can be used with AC and DC supply
 - voltage peak limited to about 2 Un
 - little effect on relay drop-out time
- Disadvantages
 - no modification of coil's own oscillating frequency
 - limitation of switching frequency

Protection Module with RC Circuit

- Advantages
 - coil oscillating frequency reduced to about 150 Hz
 - voltage peak limited to 3 Un
 - little effect on relay drop-out time
- Disadvantages
 - no protection for low voltages

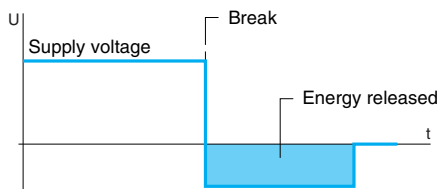

Coil voltage with diode protection module (Vdc only)

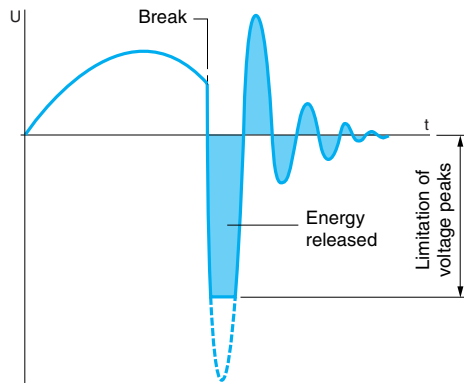

Coil voltage with varistor protection module (Vac and Vdc)

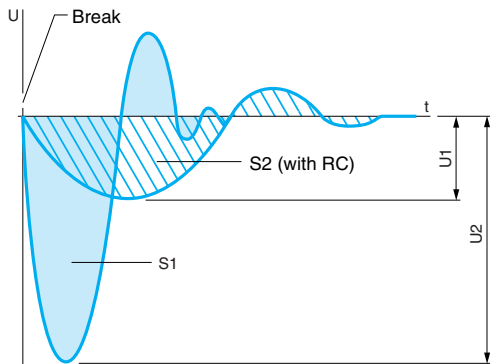

Coil voltage with RC circuit protection module (Vac only)

S1 = S2 = Energy released

Zelio® Plug-in Relays

Catalog Number Index

RE XL2●●	9	RPM23P7	16	RSB1A120ED	36	RUMC3AB1F7	24
RE XL4●●	9	RPM3	18	RSB1A120F7	36	RUMC3AB1FD	24
RE48A●●	26	RPM31B7	16	RSB1A120FD	36	RUMC3AB1GD	24
RPF2AB7	32	RPM31BD	16	RSB1A120JD	36	RUMC3AB1JD	24
RPF2ABD	32	RPM31E7	16	RSB1A120M7	36	RUMC3AB1MD	24
RPF2AF7	32	RPM31ED	16	RSB1A120ND	36	RUMC3AB1ND	24
RPF2AFD	32	RPM31F7	16	RSB1A120P7	36	RUMC3AB1P7	24
RPF2AJD	32	RPM31FD	16	RSB1A120RD	36	RUMC3AB2B7	24
RPF2AP7	32	RPM31JD	16	RSB1A120U7	36	RUMC3AB2BD	24
RPF2BB7	32	RPM31P7	16	RSB1A160B7	36	RUMC3AB2E7	24
RPF2BBD	32	RPM32B7	16	RSB1A160BD	3, 36	RUMC3AB2ED	24
RPF2BF7	32	RPM32BD	16	RSB1A160E7	36	RUMC3AB2F7	24
RPF2BFD	32	RPM32E7	16	RSB1A160ED	36	RUMC3AB2FD	24
RPF2BJD	32	RPM32ED	16	RSB1A160F7	36	RUMC3AB2GD	24
RPF2BP7	32	RPM32F7	3, 16	RSB1A160FD	36	RUMC3AB2JD	24
RPF2B●●	3	RPM32FD	16	RSB1A160JD	36	RUMC3AB2ND	24
RPM1	18	RPM32JD	16	RSB1A160M7	36	RUMC3AB2P7	24
RPM11B7	16	RPM32P7	16	RSB1A160ND	36	RUMC3AB3B7	25
RPM11BD	16	RPM33B7	16	RSB1A160P7	36	RUMC3AB3BD	25
RPM11E7	16	RPM33BD	16	RSB1A160RD	36	RUMC3AB3E7	25
RPM11ED	16	RPM33E7	16	RSB1A160U7	36	RUMC3AB3ED	25
RPM11F7	16	RPM33ED	16	RSB2A080B7	36	RUMC3AB3F7	25
RPM11FD	16	RPM33F7	16	RSB2A080BD	36	RUMC3AB3FD	25
RPM11JD	16	RPM33FD	16	RSB2A080E7	36	RUMC3AB3GD	25
RPM11P7	16	RPM33JD	16	RSB2A080ED	36	RUMC3AB3JD	25
RPM12B7	16	RPM33P7	16	RSB2A080F7	36	RUMC3AB3ND	25
RPM12BD	16	RPM4	18	RSB2A080FD	36	RUMC3AB3P7	25
RPM12E7	16	RPM41B7	16	RSB2A080JD	36	RUMF2AB1B7	24
RPM12ED	16	RPM41BD	16	RSB2A080M7	36	RUMF2AB1BD	24
RPM12F7	16	RPM41E7	16	RSB2A080ND	36	RUMF2AB1E7	24
RPM12FD	16	RPM41ED	16	RSB2A080P7	36	RUMF2AB1ED	24
RPM12JD	16	RPM41F7	16	RSB2A080RD	36	RUMF2AB1F7	24
RPM12P7	16	RPM41FD	16	RSB2A080U7	36	RUMF2AB1FD	24
RPM13B7	16	RPM41JD	16	RSZE1S35M	35–37	RUMF2AB1JD	24
RPM13BD	16	RPM41P7	16	RSZE1S48M	3, 35–37	RUMF2AB1P7	24
RPM13E7	16	RPM42B7	16	RSZL300	36	RUMF2AB2B7	24
RPM13ED	16	RPM42BD	16	RSZR215	36	RUMF2AB2BD	24
RPM13F7	16	RPM42E7	16	RUMC2AB1B7	24	RUMF2AB2E7	24
RPM13FD	16	RPM42ED	16	RUMC2AB1BD	24	RUMF2AB2ED	24
RPM13JD	16	RPM42F7	16	RUMC2AB1E7	24	RUMF2AB2F7	24
RPM13P7	16	RPM42FD	16	RUMC2AB1ED	24	RUMF2AB2FD	24
RPM2	18	RPM42JD	16	RUMC2AB1F7	24	RUMF2AB2JD	24
RPM21B7	16	RPM42P7	16	RUMC2AB1FD	24	RUMF2AB2P7	24
RPM21BD	16	RPM43B7	16	RUMC2AB1JD	24	RUMF2AB3B7	25
RPM21E7	16	RPM43BD	16	RUMC2AB1P7	24	RUMF2AB3BD	25
RPM21ED	16	RPM43E7	16	RUMC2AB2B7	24	RUMF2AB3E7	25
RPM21F7	16	RPM43ED	16	RUMC2AB2BD	24	RUMF2AB3ED	25
RPM21FD	16	RPM43F7	16	RUMC2AB2E7	24	RUMF2AB3F7	25
RPM21JD	16	RPM43FD	16	RUMC2AB2ED	24	RUMF2AB3FD	25
RPM21P7	16	RPM43JD	16	RUMC2AB2F7	24	RUMF2AB3JD	25
RPM22B7	16	RPM43P7	16	RUMC2AB2FD	24	RUMF2AB3P7	25
RPM22BD	16	RPZ1DA	17, 19	RUMC2AB2JD	24	RUMF3AB1B7	24
RPM22E7	16	RPZ1FA	17, 19	RUMC2AB2P7	24	RUMF3AB1BD	24
RPM22ED	16	RPZ3DA	17, 19	RUMC2AB3B7	25	RUMF3AB1E7	24
RPM22F7	16–17	RPZ3FA	17, 19	RUMC2AB3BD	25	RUMF3AB1ED	24
RPM22FD	16	RPZ4DA	17, 19	RUMC2AB3E7	25	RUMF3AB1F7	24
RPM22JD	16	RPZ4FA	17, 19	RUMC2AB3ED	25	RUMF3AB1FD	24
RPM22P7	16	RPZF1	15, 17–18	RUMC2AB3F7	25	RUMF3AB1JD	24
RPM23B7	16	RPZF2	15, 17–18	RUMC2AB3FD	25	RUMF3AB1P7	24
RPM23BD	16	RPZF3	15, 17–18	RUMC2AB3JD	25	RUMF3AB2B7	24
RPM23E7	16	RPZF4	15, 17–18	RUMC2AB3P7	25	RUMF3AB2BD	24
RPM23ED	16	RPZR235	17	RUMC3AB1B7	24	RUMF3AB2E7	24
RPM23F7	16	RSB1A120B7	36	RUMC3AB1BD	24	RUMF3AB2ED	24
RPM23FD	16	RSB1A120BD	36	RUMC3AB1E7	24	RUMF3AB2F7	24
RPM23JD	16	RSB1A120E7	36	RUMC3AB1ED	24	RUMF3AB2FD	24

RUMF3AB2JD 24	RXM2AB3P7TQ 8	RXM4GB1E7 7
RUMF3AB2P7 24	RXM3 10	RXM4GB1ED 7
RUMF3AB3B7 25	RXM3AB1B7 7	RXM4GB1F7 7
RUMF3AB3BD 25	RXM3AB1BD 7	RXM4GB1FD 7
RUMF3AB3E7 25	RXM3AB1E7 7	RXM4GB1JD 7
RUMF3AB3ED 25	RXM3AB1ED 7	RXM4GB1P7 7
RUMF3AB3F7 25	RXM3AB1F7 7	RXM4GB2B7 7
RUMF3AB3FD 25	RXM3AB1FD 7	RXM4GB2BD 7
RUMF3AB3GD 25	RXM3AB1JD 7	RXM4GB2E7 7
RUMF3AB3JD 25	RXM3AB1P7 7	RXM4GB2ED 7
RUMF3AB3P7 25	RXM3AB2B7 7	RXM4GB2F7 7
RUMppAB2B7 3	RXM3AB2BD 7	RXM4GB2FD 7
RUW101MW	17, 26, 29	RXM3AB2E7 7	RXM4GB2JD 7
RUW240BD	... 17, 26	RXM3AB2ED 7	RXM4GB2P7 7
RUW241P7	... 17, 26	RXM3AB2F7 7	RXM4GB2U7 7
RUW242B7	... 17, 26	RXM3AB2FD 7	RXM4GB3B7 8
RUW242P7	... 17, 26	RXM3AB2JD 7	RXM4GB3BD 8
RUZC200 26, 28	RXM3AB2P7 7	RXM4GB3E7 8
RUZC2M	... 23, 26–27	RXM4 10	RXM4GB3ED 8
RUZC3M	... 23, 26–27	RXM4AB1B7 7	RXM4GB3F7 8
RUZL420 26, 28	RXM4AB1B7TQ 9	RXM4GB3FD 8
RUZS2 26, 28	RXM4AB1BD 7	RXM4GB3JD 8
RUZSC2M	.. 23, 26–27	RXM4AB1BDTQ 9	RXM4GB3P7 8
RUZSC3M	.. 23, 26–27	RXM4AB1E7 7	RXMpAB2F7 3
RUZSF3M	.. 23, 26, 28	RXM4AB1E7TQ 9	RXZ400 9, 11
RXM021BN 9, 17	RXM4AB1ED 7	RXZE2DA	9, 11, 17, 19
RXM021FP 9, 17	RXM4AB1EDTQ 9	RXZE2FA	.9, 11, 17, 19
RXM021RB 9, 17	RXM4AB1F7 7	RXZE2M114	.6, 9–11
RXM040W 9, 17	RXM4AB1F7TQ 9	RXZE2M114M	.6, 9–10
RXM041BN7 9, 17	RXM4AB1FD 7	RXZE2S108M	.6, 9–10
RXM041FU7 9, 17	RXM4AB1FDTQ 9	RXZE2S111M	.6, 9–10
RXM2 10	RXM4AB1JD 7	RXZE2S114M	.6, 9–10
RXM2AB1B7 7	RXM4AB1JDTQ 9	RXZL420 9, 11
RXM2AB1B7TQ 9	RXM4AB1MD 7	RXZL520	...9, 17, 26
RXM2AB1BD 7	RXM4AB1MDTQ 9	RXZR335 9, 11
RXM2AB1BDTQ 9	RXM4AB1P7 7	RXZS2 9, 11
RXM2AB1E7 7	RXM4AB1P7TQ 9	RZM021BN 36
RXM2AB1ED 7	RXM4AB1U7 7	RZM021FP 36
RXM2AB1F7 7	RXM4AB2B7 7	RZM021RB 36
RXM2AB1F7TQ 9	RXM4AB2B7TQ 9	RZM031BN 36
RXM2AB1FD 7	RXM4AB2BD 7	RZM031FPD 36
RXM2AB1JD 7	RXM4AB2BDTQ 9	RZM031RB 36
RXM2AB1P7 7	RXM4AB2E7 7	RZM040W 36
RXM2AB1P7TQ 9	RXM4AB2ED 7	RZM041BN7 36
RXM2AB2B7 7	RXM4AB2F7 7	RZM041FU7 36
RXM2AB2B7TQ 9	RXM4AB2FD 7		
RXM2AB2BD 7	RXM4AB2GD 7		
RXM2AB2E7 7	RXM4AB2JD 7		
RXM2AB2ED 7	RXM4AB2P7 7		
RXM2AB2F7 7	RXM4AB2P7TQ 9		
RXM2AB2FD 7	RXM4AB3B7 8		
RXM2AB2JD 7	RXM4AB3B7TQ 8		
RXM2AB2P7 7	RXM4AB3BD 8		
RXM2AB2P7TQ 9	RXM4AB3BDTQ 8		
RXM2AB3B7 8	RXM4AB3E7 8		
RXM2AB3B7TQ 8	RXM4AB3ED 8		
RXM2AB3BD 8	RXM4AB3F7 8		
RXM2AB3BDTQ 8	RXM4AB3FD 8		
RXM2AB3E7 8	RXM4AB3GD 8		
RXM2AB3ED 8	RXM4AB3JD 8		
RXM2AB3F7 8	RXM4AB3P7 8		
RXM2AB3FD 8	RXM4AB3P7TQ 8		
RXM2AB3JD 8	RXM4GB1B7 7		
RXM2AB3P7 8	RXM4GB1BD 7		

Schneider Electric USA

8001 Highway 64 East
Knightdale, NC 27545
1-888-Square D
1-888-778-2733
www.us.Telemecanique.com

8501CT0601R1/08 © 2005–2008 Schneider Electric All Rights Reserved
Replaces 8501CT0601 dated 06/2006

01/2008