

# 10. Schematic Diagram

## 10-1 MAIN

### 10-1-1 MAIN 1

This Document can not be used without Samsung's authorization.



This drawing is property of SEC  
Use or copy of this drawing without proper permission from the appropriate  
technical-document managing department is prohibited.

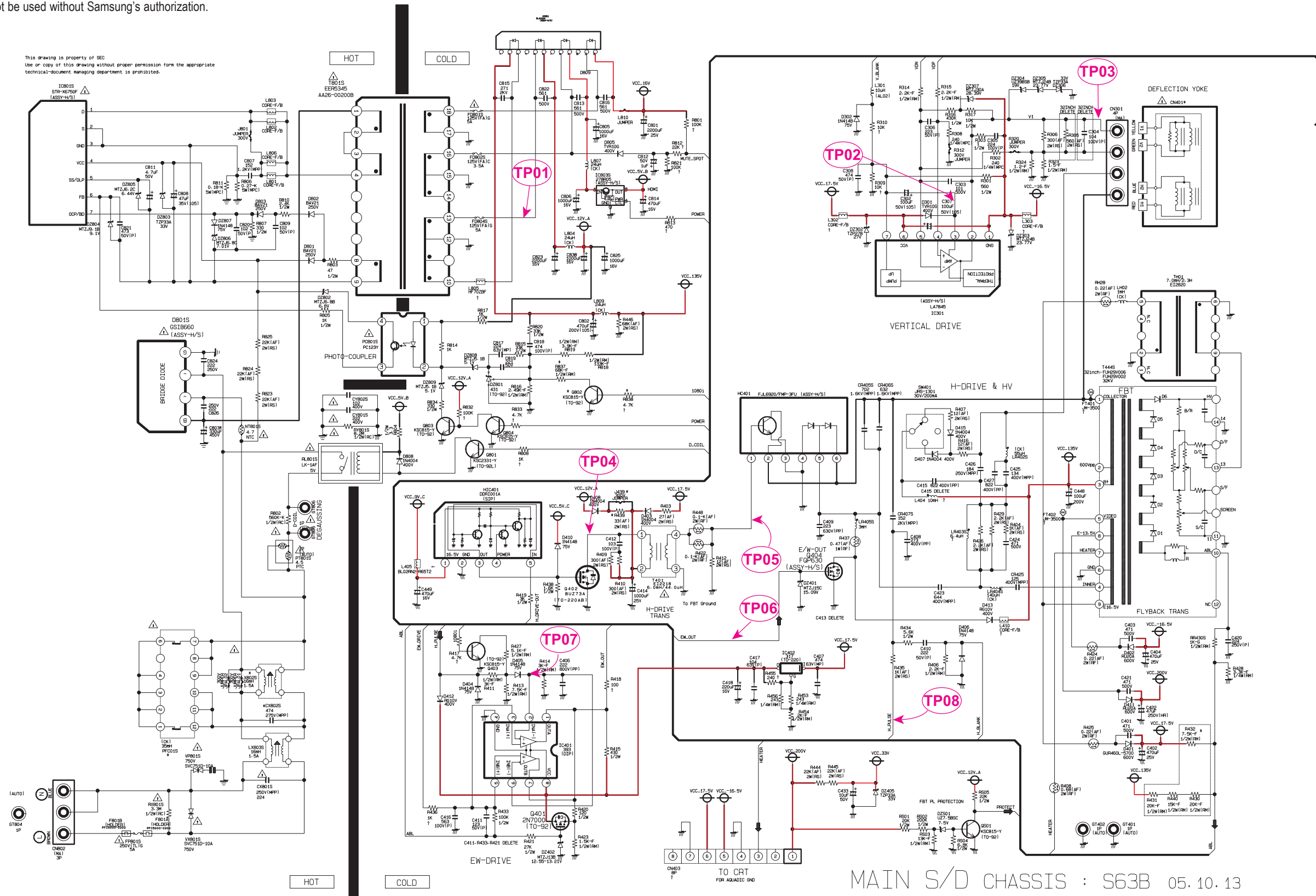

MAIN S/D CHASSIS : S63B 05.10.13

10-1-2 MAIN 2

This Document can not be used without Samsung's authorization.

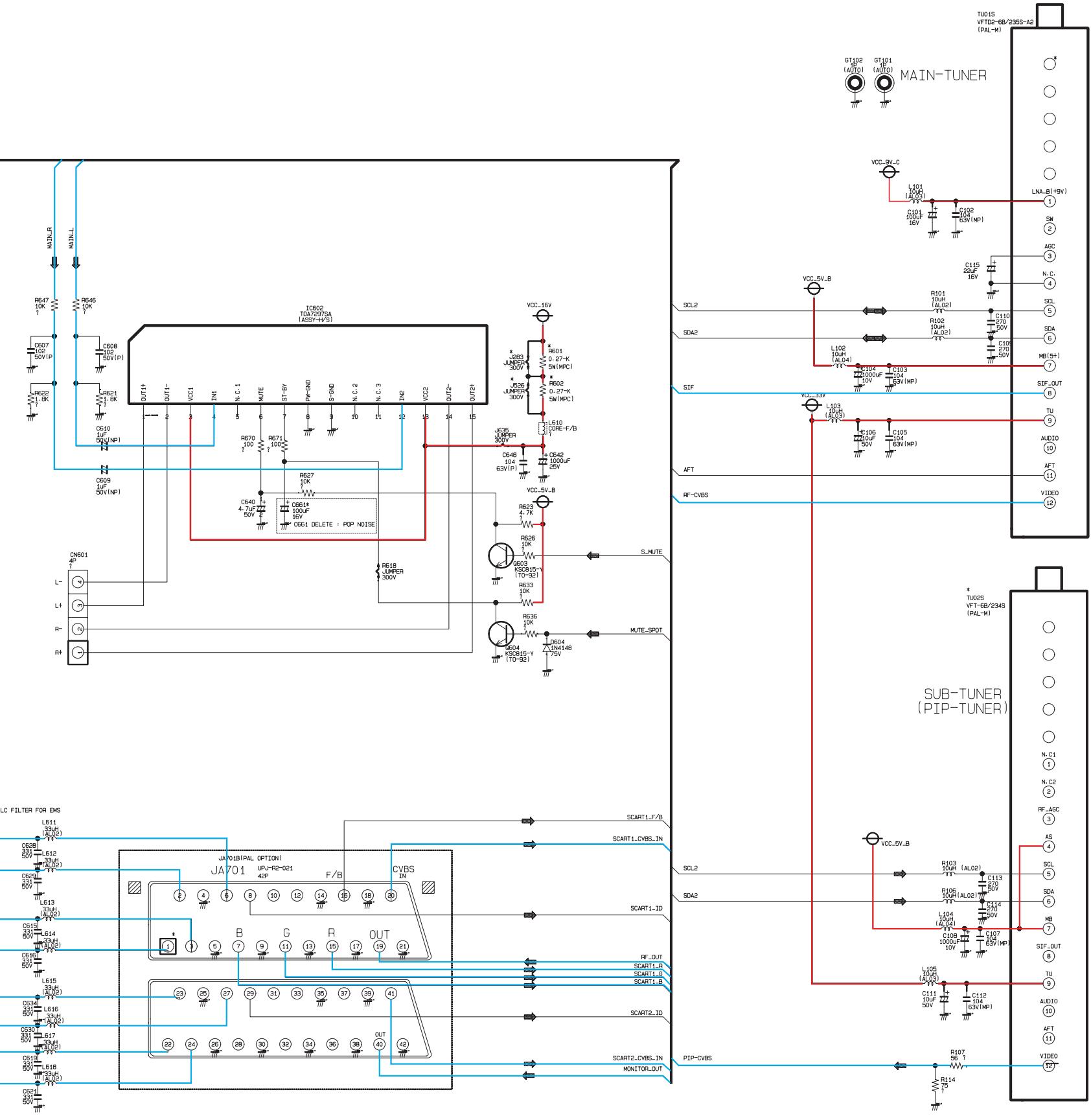
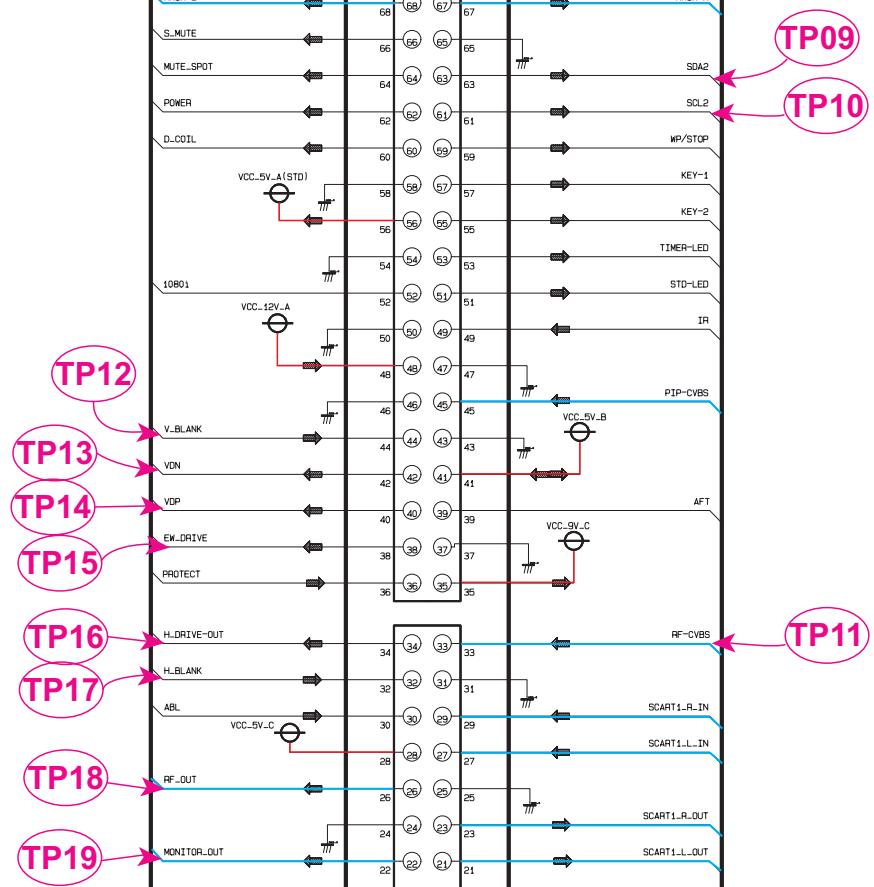

# WAVEFORM

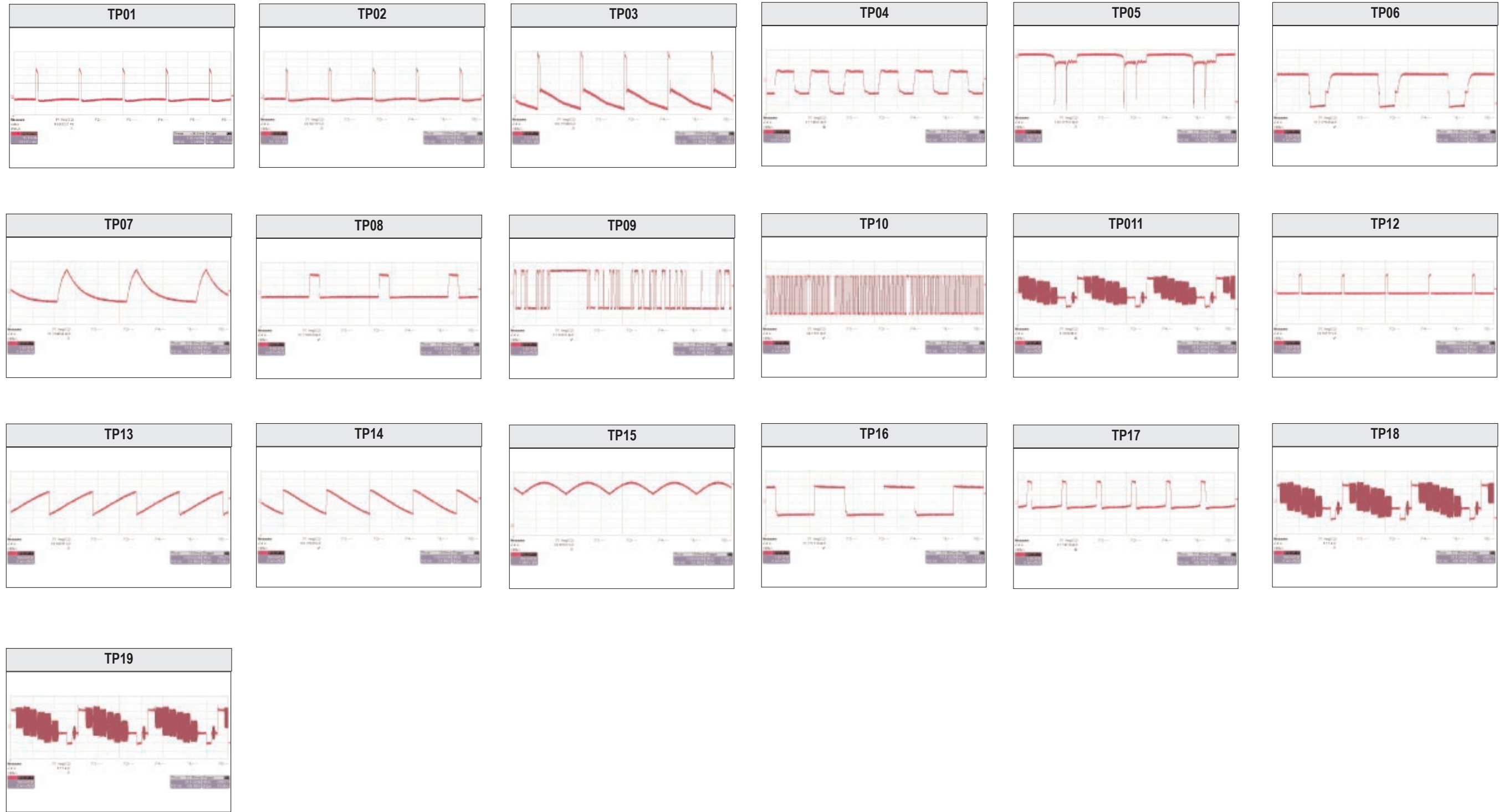

# 10-2 Feature Box

## 10-2-1 Feature Box 1

This Document can not be used without Samsung's authorization.

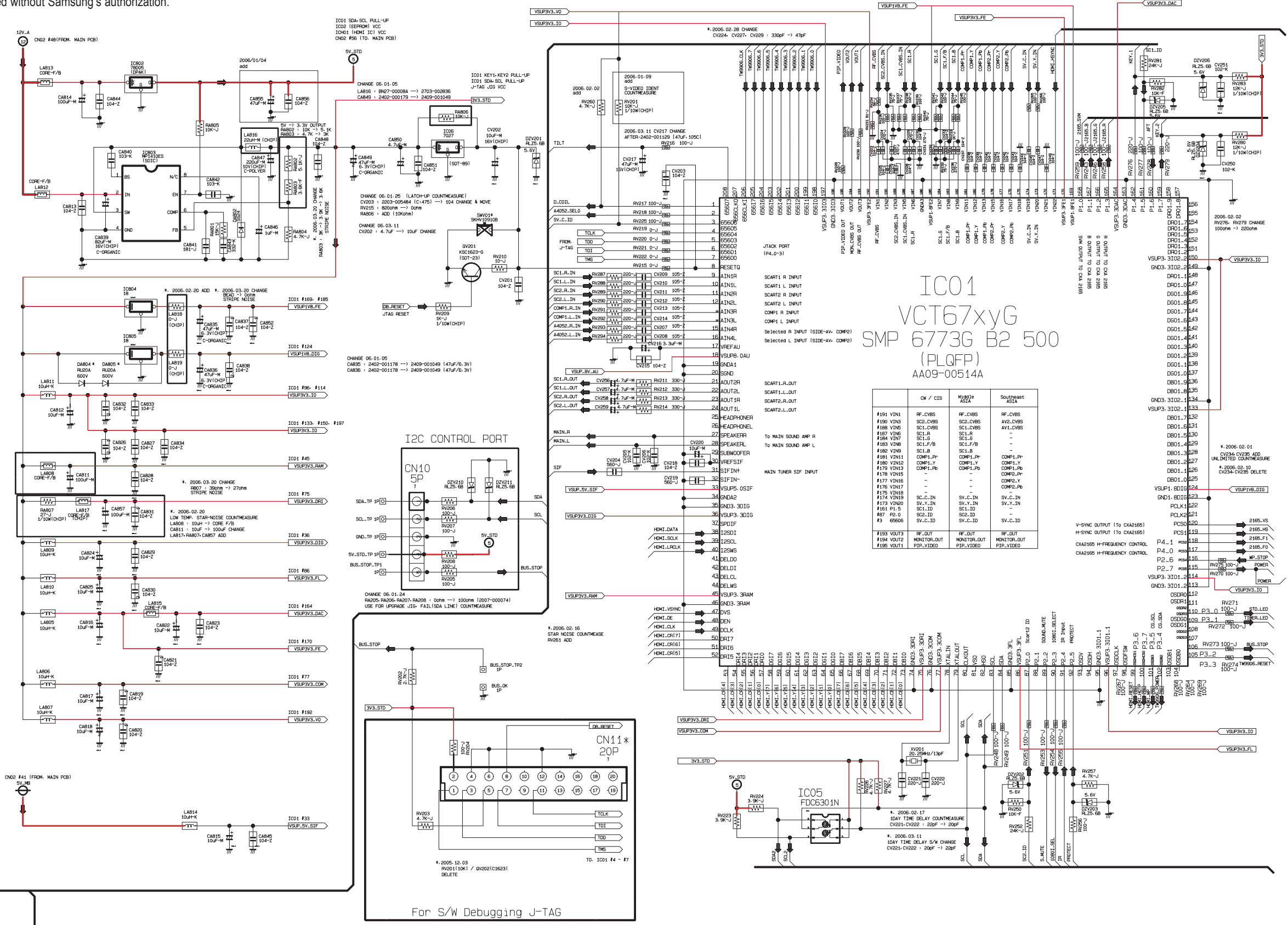
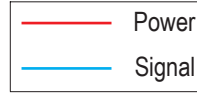

IC01  
VCT67xyG  
SMP 6773G B2 500  
(PLQFP)  
AA09-00514A

Pin	Symbol	Function	Package	Notes
#191	VIN1	RF_CVBS	RF_CVBS	
#190	VIN3	SC2_CVBS	SC2_CVBS	
#188	VIN5	SC1_CVBS	SC1_CVBS	
#187	VIN6	SC1_R	SC1_R	
#184	VIN7	SC1_G	SC1_G	
#183	VIN8	SC1_B	SC1_B	
#182	VIN9	SC1_FB	SC1_FB	
#181	VIN11	COMPL_P	COMPL_P	
#180	VIN12	COMPL_Y	COMPL_Y	
#179	VIN13	COMPL_B	COMPL_B	
#178	VIN15	COMPL_R	COMPL_R	
#177	VIN16	COMPL_G	COMPL_G	
#176	VIN17	COMPL_P	COMPL_P	
#175	VIN18	SV_C_IN	SV_C_IN	
#174	VIN19	SV_Y_IN	SV_Y_IN	
#173	VIN20	SV_Y_IN	SV_Y_IN	
#172	VIN21	SC1_ID	SC1_ID	
#171	VIN22	SC2_ID	SC2_ID	
#170	VIN23	SC2_ID	SC2_ID	
#3	66606	SV_C_ID	SV_C_ID	
#193	VOUT3	RF_OUT	RF_OUT	
#194	VOUT2	MONITOR_OUT	MONITOR_OUT	
#195	VOUT1	PIP_VIDEO	PIP_VIDEO	

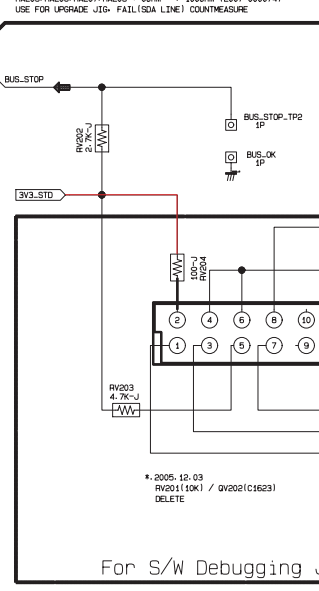
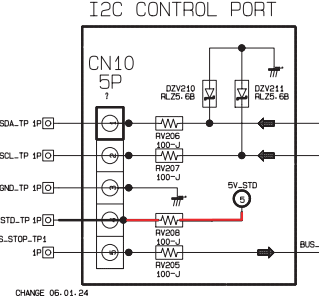

### 10-2-2 Feature Box 2

This Document can not be used without Samsung's authorization.

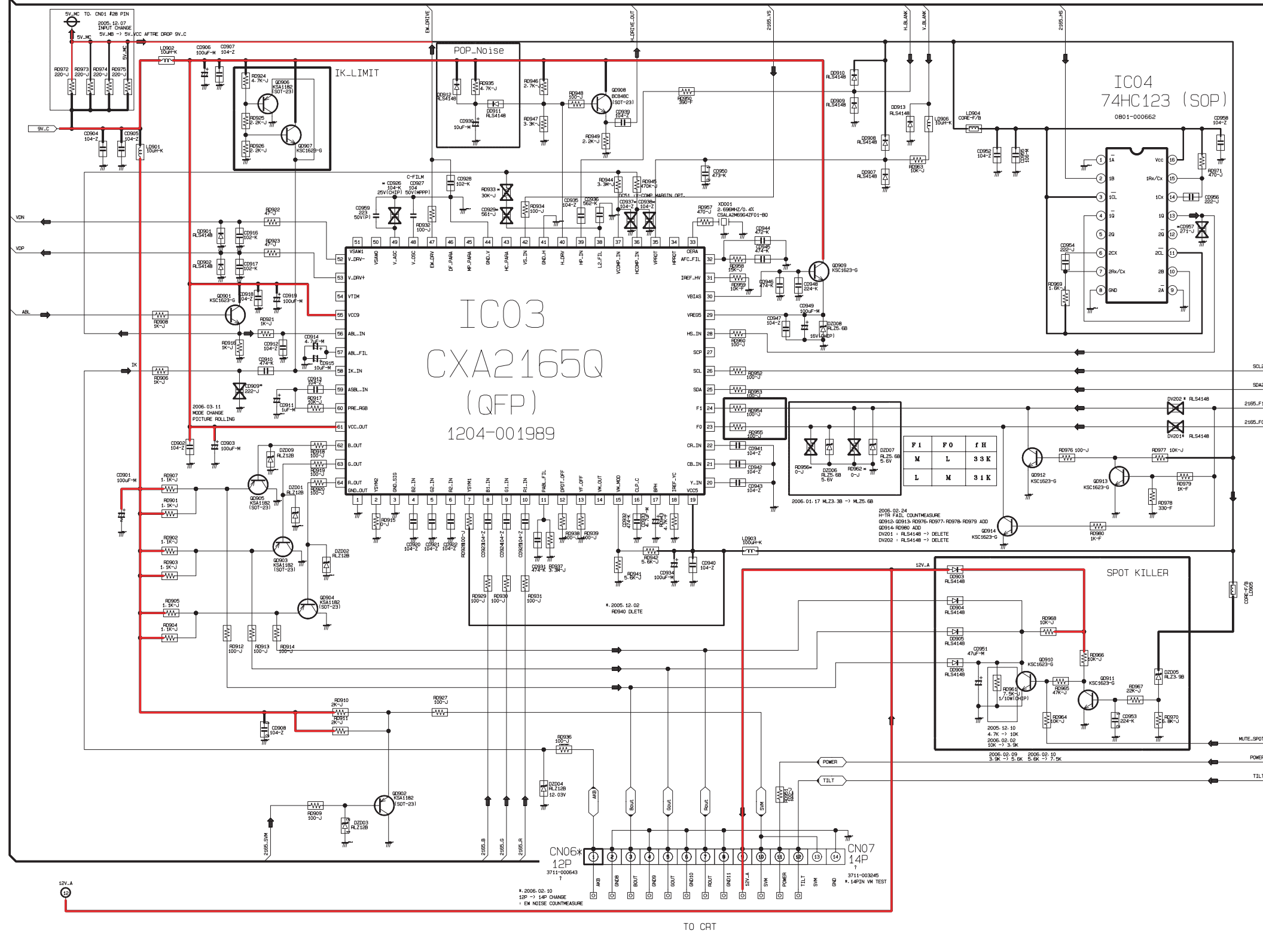

### 10-2-3 Feature Box 3

This Document can not be used without Samsung's authorization.

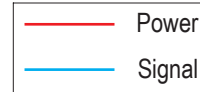

Don't use Material  
 CD909, CD926, CD929, CD937  
 CD938, CD957, RD933, RD956  
 RD962, CN06, CN11, LH010  
 CP024, RP008, RP016, RV262  
 RV263, SWV01, DV201, DV202

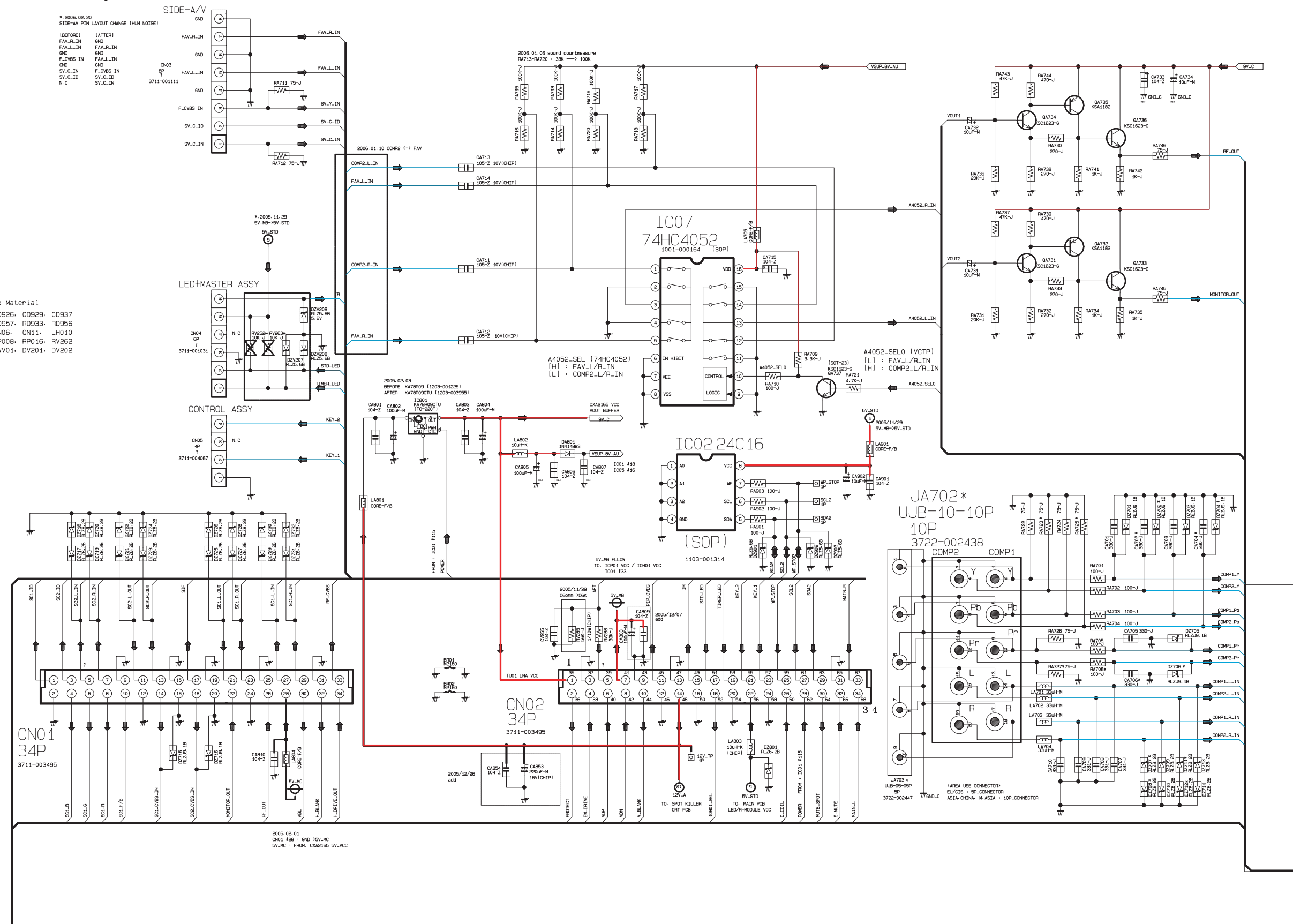

### 10-2-4 Feature Box 4

This Document can not be used without Samsung's authorization.

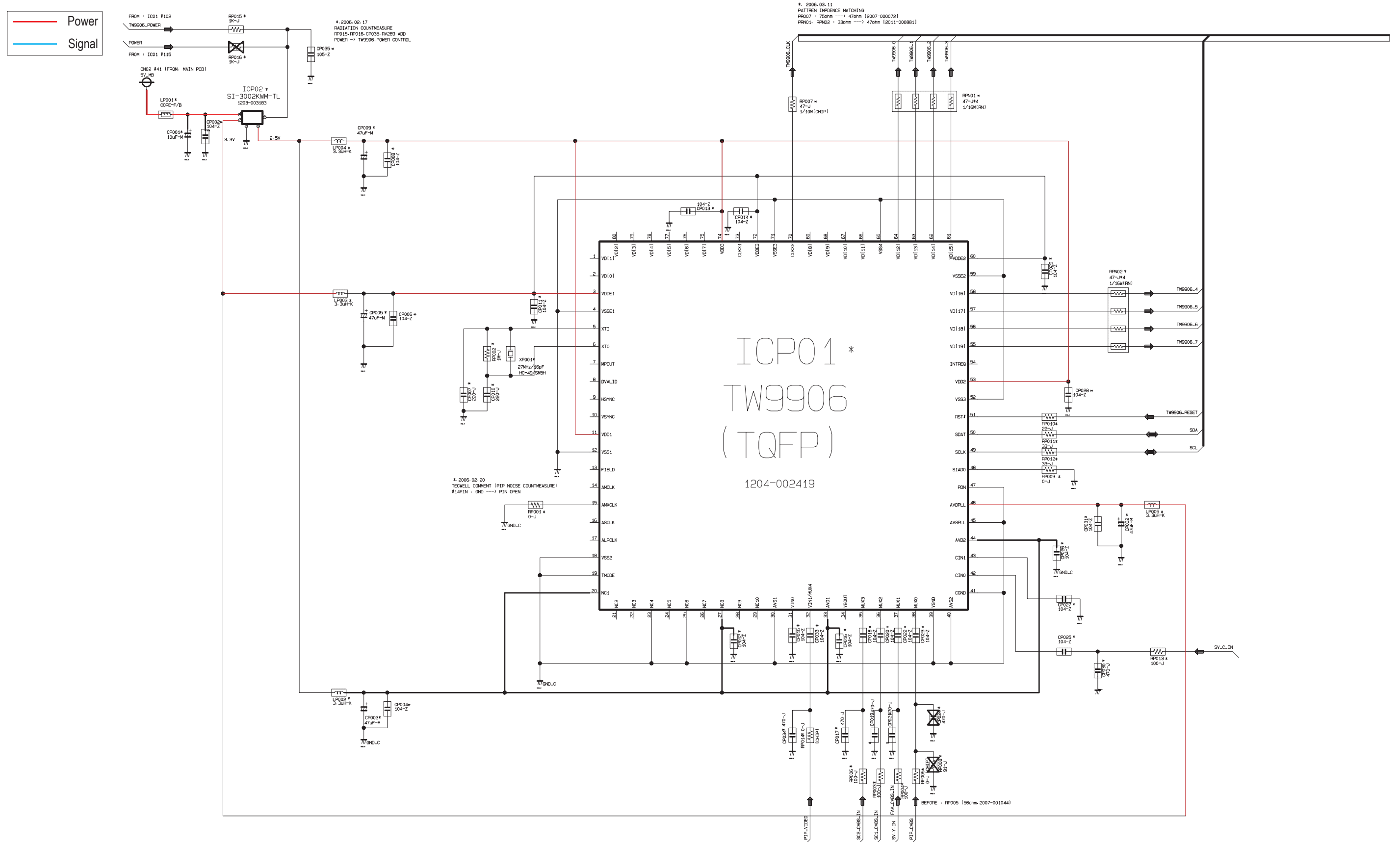

### 10-2-5 Feature Box 5

This Document can not be used without Samsung's authorization.

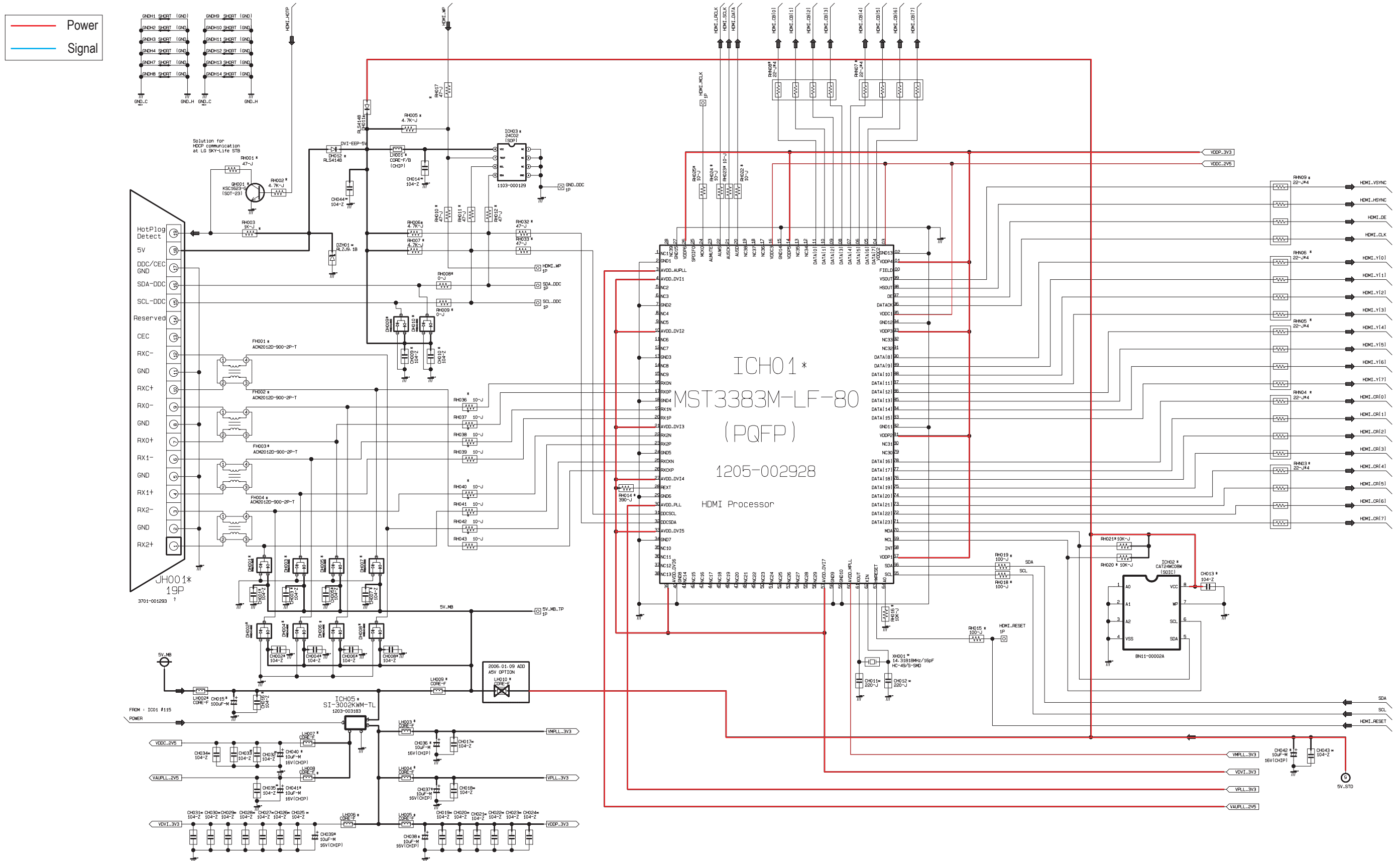



# 10-3 CRT

This Document can not be used without Samsung's authorization.

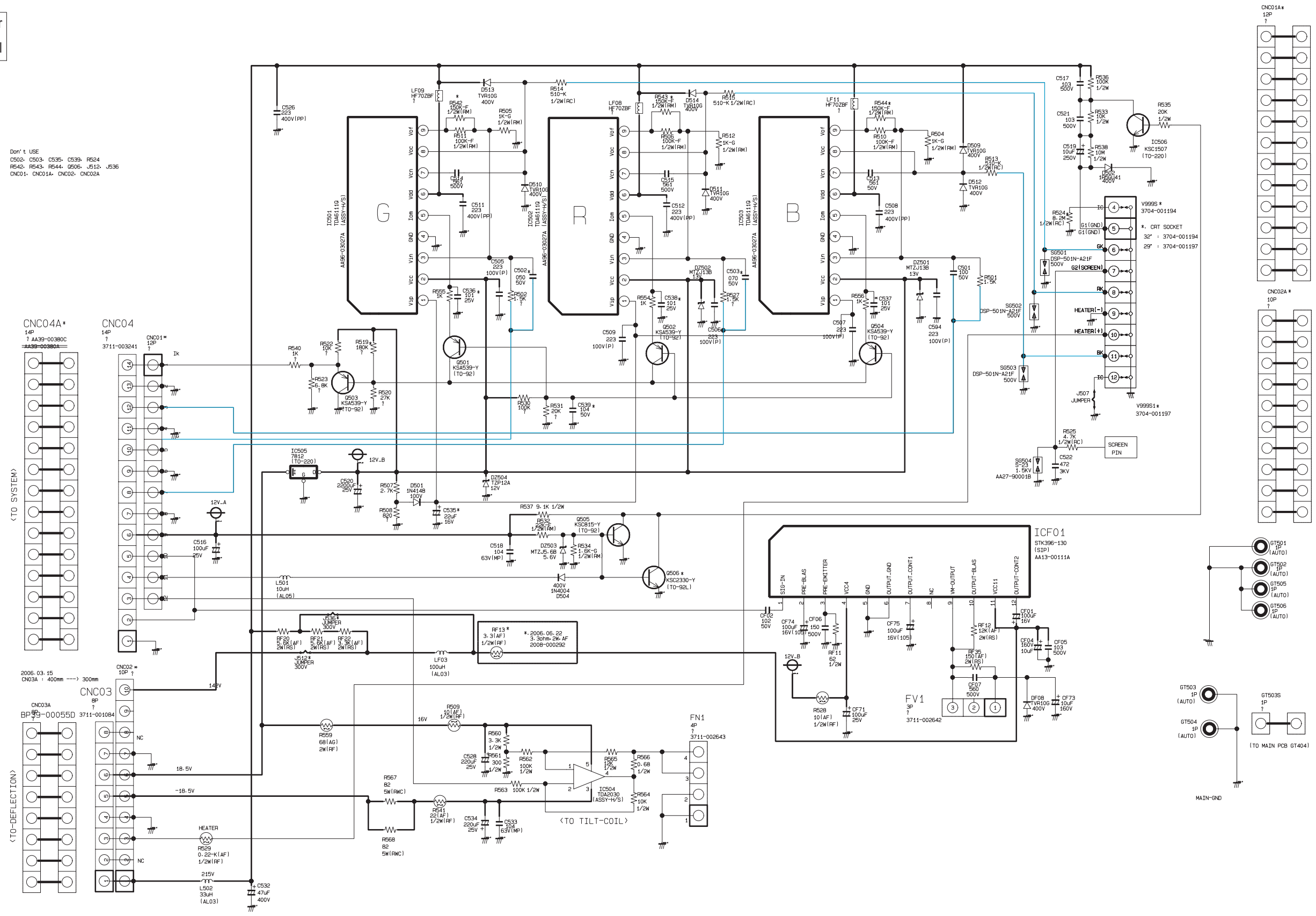
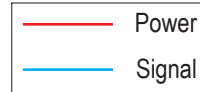



# 10-5 CONTROL

This Document can not be used without Samsung's authorization.

