

DVD Player

DVP/HTP3360K

Service

DVP3360K/55

DVP3360K/98

DVP3360K/75

HTP3360K/98

Service

Service



Service Manual

TABLE OF CONTENTS

	Page
. Technical Specifications.....	1-2
. Safety Instruction, Warning & Notes.....	1-3
. QSG & DFU Instruction.....	2-1
. Mechanical and Dismantling Instructions.....	3-1
. Software Version & Upgrades, Region Code Change.....	4-1
. Trouble Shooting Chart.....	5-1
. Wiring Diagram.....	6-1
. Electrical Diagrams and Print-layouts.....	7-1
. Set Mechanical Exploded view & Part list.....	8-1
. Revision List.....	9-1

©Copyright 2009 Philips Consumer Electronics B.V. Eindhoven, The Netherlands
All rights reserved. No part of this publication may be reproduced, stored in a retrieval system or transmitted, in any form or by any means, electronic, mechanical, photocopying, or otherwise without the prior permission of Philips.

**CLASS 1
LASER PRODUCT**

Published by SL- MW 1001 BU AVM Printed in The Netherlands Subject to modification

GB 3141 785 33453

Version 1.3

PHILIPS

Specification For DVP3360K/55



Note

- Specification and design are subject to change without notice.

Accessories supplied

- Quick Start Guide
- Remote control and batteries

Playback media

- DVD-Video, Video CD/SVCD, Audio CD, CD-R/CD-RW, DVD+R/+RW, DVD-R/-RW, DivX-CD, Picture CD, MP3-CD, WMA-CD, USB flash drive

USB

- Compatibility: Hi-Speed USB (2.0)
- Class support: UMS (USB Mass Storage Class)

TV standard

- Number of lines:
 - 625 (PAL/50Hz); 525 (NTSC/60Hz)
- Playback: Multi-standard (PAL/NTSC)

Video performance

- Video DAC: 12 bits, 108 MHz
- Y Pb Pr: 0.7 Vpp ~ 75 ohm
- Video output: 1 Vpp ~ 75 ohm

Video format

- Digital compression:
 - MPEG 2: DVD/SVCD
 - MPEG 1: VCD/DivX
- Horizontal resolution:
 - DVD: 720/1920 pixels (50 Hz); 720/1920 pixels (60 Hz)
 - VCD: 352 pixels (50 Hz); 352 pixels (60 Hz)
- Vertical resolution:
 - DVD: 576/1080 lines (50 Hz); 480/1080 lines (60 Hz)
 - VCD: 288 lines (50 Hz); 240 lines (60 Hz)

Audio performance

- DA converter: 24 bits, 192 kHz

- Frequency response:
 - DVD: 4 Hz - 22 kHz (48 kHz);
4 Hz - 44 kHz (96 kHz)
 - SVCD: 4 Hz - 20 kHz (44.1 kHz);
4 Hz - 22 kHz (48 kHz)
 - CD/VCD: 4 Hz - 20 kHz (44.1 kHz)
- Signal-Noise (1 kHz): > 90 dB (A-weighted)
- Dynamic range (1 kHz): > 80 dB (A-weighted)
- Crosstalk (1 kHz): > 70 dB
- Distortion/noise (1 kHz): > 65 dB
- MPEG MP3: MPEG Audio L3

Audio format

- Digital:
 - MPEG/AC-3/PCM: Compressed digital (16, 20, 24 bits fs, 44.1, 48, 96 kHz)
 - MP3 (ISO 9660): 96, 112, 128, 256 kbps & variable bit rate fs, 32, 44.1, 48 kHz
- Analogue sound stereo
- Dolby surround compatible downmix from Dolby Digital multi-channel sound

Connections

- Scart output: Euroconnector
- Y Pb Pr output: Cinch 3x
- Video output: Cinch (yellow)
- Audio output (L+R): Cinch (white/red)
- Digital output:
 - 1 coaxial: IEC60958 for CDDA/LPCM;
IEC61937 for MPEG 1/2, Dolby Digital
- HDMI output

Main unit

- Dimensions (w x h x d): 360 x 38 x 203 (mm)
- Net Weight: approximately 1.3 kg

Power

- Power supply rating:
 - For U.K.: 240 V; 50 Hz
 - For the rest of the Europe: 230 V; 50Hz
- Power consumption: < 12 W
- Power consumption in standby mode: < 1 W

Laser Specification

- Type: Semiconductor laser InGaAlP (DVD), AlGaAs (CD)
- Wave length: 658 nm (DVD), 790 nm (CD)
- Output Power: 7.0 mW (DVD), 10.0 mW (VCD/CD)
- Beam divergence: 60 degrees

Specification For DVP/HTP3360K/98



Note

- Specification and design are subject to change without notice.

Accessories supplied

- Quick Start Guide
- Remote control and batteries
- Audio/video cables
- Power cable

Playback media

- DVD-Video, Video CD/SVCD, Audio CD, CD-R/CD-RW, DVD+R/+RW, DVD-R/-RW, DivX-CD, Picture CD, MP3-CD, WMA-CD, USB flash drive

USB

- Compatibility: Hi-Speed USB (2.0)
- Class support: UMS (USB Mass Storage Class)

TV standard

- Number of lines:
 - 625 (PAL/50Hz); 525 (NTSC/60Hz)
- Playback: Multi-standard (PAL/NTSC)

Video performance

- Video DAC: 12 bits, 108 MHz
- Y Pb Pr: 0.7 V_{pp} ~ 75 ohm
- Video output: 1 V_{pp} ~ 75 ohm

Video format

- Digital compression:
 - MPEG 2: DVD/SVCD
 - MPEG 1: VCD/DivX
- Horizontal resolution:
 - DVD: 720/1920 pixels (50 Hz); 720/1920 pixels (60 Hz)
 - VCD: 352 pixels (50 Hz); 352 pixels (60 Hz)
- Vertical resolution:
 - DVD: 576/1080 lines (50 Hz); 480/1080 lines (60 Hz)
 - VCD: 288 lines (50 Hz); 240 lines (60 Hz)

Audio performance

- DA converter: 24 bits, 192 kHz
- Frequency response:
 - DVD: 4 Hz - 22 kHz (48 kHz);
4 Hz - 44 kHz (96 kHz)
 - SVCD: 4 Hz - 20 kHz (44.1 kHz);
4 Hz - 22 kHz (48 kHz)
 - CD/VCD: 4 Hz - 20 kHz (44.1 kHz)
- Signal-Noise (1 kHz): > 90 dB (A-weighted)
- Dynamic range (1 kHz): > 80 dB (A-weighted)
- Crosstalk (1 kHz): > 70 dB
- Distortion/noise (1 kHz): > 65 dB
- MPEG MP3: MPEG Audio L3

Audio format

- Digital:
 - MPEG/AC-3/PCM: Compressed digital (16, 20, 24 bits fs, 44.1, 48, 96 kHz)
 - MP3 (ISO 9660): 96, 112, 128, 256 kbps & variable bit rate fs, 32, 44.1, 48 kHz
- Analog sound stereo
- Dolby surround compatible downmix from Dolby Digital multi-channel sound

Connections

- Y Pb Pr output: Cinch 3x
- Video output: Cinch (yellow)
- Audio output (L+R): Cinch (white/red)
- Digital output:
 - 1 coaxial: IEC60958 for CDDA/LPCM;
IEC61937 for MPEG 1/2, Dolby Digital
- HDMI output

Main unit

- Dimensions (w x h x d): 360 x 37 x 209 (mm)
- Net Weight: approximately 1.3 kg

Power

- Power supply rating: 110 V - 240V; 50/60 Hz
- Power consumption: < 12 W
- Power consumption in standby mode: < 1 W

Laser Specification

- Type: Semiconductor laser InGaAlP (DVD), AlGaAs (CD)
- Wave length: 658 nm (DVD), 790 nm (CD)
- Output Power: 7.0 mW (DVD), 10.0 mW (VCD/CD)
- Beam divergence: 60 degrees

Specification For DVP3360K/75



Note

- Specification and design are subject to change without notice.

Accessories supplied

- Quick Start Guide
- Remote control and batteries
- Audio/video cables
- Power cable (except for Australia and New Zealand)

Playback media

- DVD-Video, Video CD/SVCD, Audio CD, CD-R/CD-RW, DVD+R/+RW, DVD-R/-RW, DivX-CD, Picture CD, MP3-CD, WMA-CD, USB flash drive

USB

- Compatibility: Hi-Speed USB (2.0)
- Class support: UMS (USB Mass Storage Class)

TV standard

- Number of lines:
 - 625 (PAL/50Hz); 525 (NTSC/60Hz)
- Playback: Multi-standard (PAL/NTSC)

Video performance

- Video DAC: 12 bits, 108 MHz
- Y Pb Pr: 0.7 Vpp ~ 75 ohm
- Video output: 1 Vpp ~ 75 ohm

Video format

- Digital compression:
 - MPEG 2: DVD/SVCD
 - MPEG 1: VCD/DivX
- Horizontal resolution:
 - DVD: 720/1920 pixels (50 Hz); 720/1920 pixels (60 Hz)
 - VCD: 352 pixels (50 Hz); 352 pixels (60 Hz)
- Vertical resolution:
 - DVD: 576/1080 lines (50 Hz); 480/1080 lines (60 Hz)
 - VCD: 288 lines (50 Hz); 240 lines (60 Hz)

Audio performance

- DA converter: 24 bits, 192 kHz
- Frequency response:
 - DVD: 4 Hz - 22 kHz (48 kHz); 4 Hz - 44 kHz (96 kHz)
 - SVCD: 4 Hz - 20 kHz (44.1 kHz); 4 Hz - 22 kHz (48 kHz)
 - CD/VCD: 4 Hz - 20 kHz (44.1 kHz)
- Signal-Noise (1 kHz): > 90 dB (A-weighted)
- Dynamic range (1 kHz): > 80 dB (A-weighted)
- Crosstalk (1 kHz): > 70 dB
- Distortion/noise (1 kHz): > 65 dB
- MPEG MP3: MPEG Audio L3

Audio format

- Digital:
 - MPEG/AC-3/PCM: Compressed digital (16, 20, 24 bits fs, 44.1, 48, 96 kHz)
 - MP3 (ISO 9660): 96, 112, 128, 256 kbps & variable bit rate fs, 32, 44.1, 48 kHz
- Analog sound stereo
- Dolby surround compatible downmix from Dolby Digital multi-channel sound

Connections

- Y Pb Pr output: Cinch 3x
- Video output: Cinch (yellow)
- Audio output (L+R): Cinch (white/red)
- Digital output:
 - 1 coaxial: IEC60958 for CDDA/LPCM; IEC61937 for MPEG 1/2, Dolby Digital
- HDMI output

Main unit

- Dimensions (w x h x d): 360 x 37 x 209 (mm)
- Net Weight: approximately 1.3 kg

Power

- Power supply rating: 110 V - 240V; 50/60 Hz
- Power consumption: < 12 W
- Power consumption in standby mode: < 1 W

Laser Specification

- Type: Semiconductor laser InGaAlP (DVD), AlGaAs (CD)
- Wave length: 658 nm (DVD), 790 nm (CD)
- Output Power: 7.0 mW (DVD), 10.0 mW (VCD/CD)
- Beam divergence: 60 degrees

Safety instruction, Warning & Notes

Safety instruction

1. General safety

Safety regulations require that during a repair:

- . Connect the unit to the mains via an isolation transformer.
- . Replace safety components indicated by the symbol , only by components identical to the original ones. Any other component substitution (other than original type) may increase risk of fire or electrical shock hazard.

Safety regulations require that after a repair, you must return the unit in its original condition. Pay, in particular, attention to the following points:

- . Route the wires/cables correctly, and fix them with the mounted cable clamps.
- . Check the insulation of the mains lead for external damage.
- . Check the electrical DC resistance between the mains plug and the secondary side:
 - 1) Unplug the mains cord, and connect a wire between the two pins of the mains plug.
 - 2) Set the mains switch the "on" position (keep the mains cord unplug).
 - 3) Measure the resistance value between the mains plug and the front panel, controls, and chassis bottom.
 - 4) Repair or correct unit when the resistance measurement is less than 1M Ω .
 - 5) Verify this, before you return the unit to the customer/user (ref. UL-standard no. 1492).
 - 6) Switch the unit "off", and remove the wire between the two pins of the mains plug.

2. Laser safety

This unit employs a laser. Only qualified service personnel may remove the cover, or attempt to service this device (due to possible eye injury).

Laser device unit

Type	: Semiconductor laser GaAlAs
Wavelength	: 650nm (DVD)
	: 780nm (VCD/CD)
Output power	: 7mW (DVD)
	: 10mW (DVD /CD)

Beam divergence: 60 degree

Note: Use of controls or adjustments or performance of procedure other than those specified herein, may result in hazardous radiation exposure. Avoid direct exposure to beam.

Warning

1. General

. All ICs and many other semiconductors are susceptible to electrostatic discharges (ESD). Careless handling during repair can reduce life drastically. Make sure that, during repair, you are at the same potential as the mass of the set by a wristband with resistance. Keep components and tools at this same potential. Available ESD protection equipment:

- 1) Complete kit ESD3 (small tablemat, wristband, connection box, extension cable and earth cable) 4822 310 10671.
- 2) Wristband tester 4822 344 13999.

. Be careful during measurements in the live voltage section. The primary side of the power supply, including the heat sink, carries live mains voltage when you connect the player to the mains (even when the player is "off!"). It is possible to touch copper tracks and/or components in this unshielded primary area, when you service the player. Service personnel must take precautions to prevent touching this area or components in this area. A "lighting stroke" and a stripe-marked printing on the printed wiring board, indicate the primary side of the power supply.

. Never replace modules, or components, while the unit is "on".

2. Laser

- . The use of optical instruments with this product, will increase eye hazard.
- . Only qualified service personnel may remove the cover or attempt to service this device, due to possible eye injury.
- . Repair handling should take place as much as possible with a disc loaded inside the player.
- . Text below is placed inside the unit, on the laser cover shield:

CAUTION: VISIBLE AND INVISIBLE LASER RADIATION WHEN OPEN, AVOID EXPOSURE TO BEAM.

Notes: Manufactured under licence from Dolby Laboratories. The double-D symbol is trademarks of Dolby Laboratories, Inc. All rights reserved.

Notes

Lead-Free requirement for service

IDENTIFICATION:

Regardless of special logo (not always indicated) 

One must treat all sets from 1.1.2005 onwards, according next rules.

***Important note:** In fact also products a little older can also be treated in this way as long as you avoid mixing solder-alloys (leaded/ lead-free). So best to always use SAC305 and the higher temperatures belong to this.*

Due to lead-free technology some rules have to be respected by the workshop during a repair:

- Use only lead-free solder alloy Philips SAC305 with order code 0622 149 00106. If lead-free solder-paste is required, please contact the manufacturer of your solder-equipment. In general use of solder-paste within workshops should be avoided because paste is not easy to store and to handle.
 - Use only adequate solder tools applicable for lead-free solder alloy. The solder tool must be able
 - To reach at least a solder-temperature of 400°C,
 - To stabilize the adjusted temperature at the solder-tip
 - To exchange solder-tips for different applications.
 - Adjust your solder tool so that a temperature around 360°C – 380°C is reached and stabilized at the solder joint. Heating-time of the solder-joint should not exceed ~ 4 sec. Avoid temperatures above 400°C otherwise wear-out of tips will rise drastically and flux-fluid will be destroyed. To avoid wear-out of tips switch off un-used equipment, or reduce heat.
 - Mix of lead-free solder alloy / parts with leaded solder alloy / parts is possible but PHILIPS recommends strongly to avoid mixed solder alloy types (leaded and lead-free). If one cannot avoid, clean carefully the solder-joint from old solder alloy and re-solder with new solder alloy (SAC305).
- Use only original spare-parts listed in the Service-Manuals. Not listed standard-material (commodities) has to be purchased at external companies.
 - Special information for BGA-ICs:
 - always use the 12nc-recognizable soldering temperature profile of the specific BGA (for de-soldering always use highest lead-free temperature profile, in case of doubt)
 - lead free BGA-ICs will be delivered in so-called 'dry-packaging' (sealed pack including a silica gel pack) to protect the IC against moisture. After opening, dependent of MSL-level seen on indicator-label in the bag, the BGA-IC possibly still has to be baked dry. This will be communicated via AYS-website.

Do not re-use BGAs at all.
 - For sets produced before 1.1.2005, containing leaded soldering-tin and components, all needed spare-parts will be available till the end of the service-period. For repair of such sets nothing changes.
 - On our website:

www.atyourservice.ce.Philips.com

You find more information to:

 - BGA-de-/soldering (+ baking instructions)
 - Heating-profiles of BGAs and other ICs used in Philips-sets

You will find this and more technical information within the "magazine", chapter "workshop news". For additional questions please contact your local repair-helpdesk.

3

The following excerpt of the Quick Start Guide serves as an introduction to the set. The complete Direction For Use can be download in different languages from Philips Customer Contact & Support site: www.p4c.philips.com

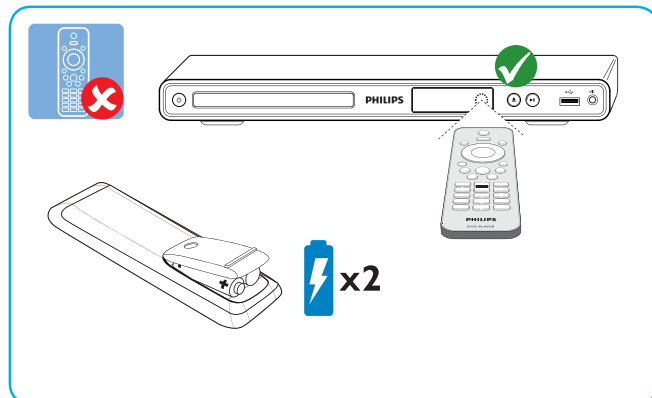
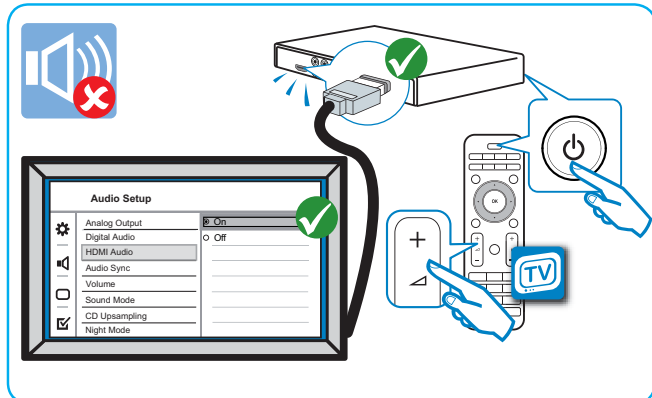
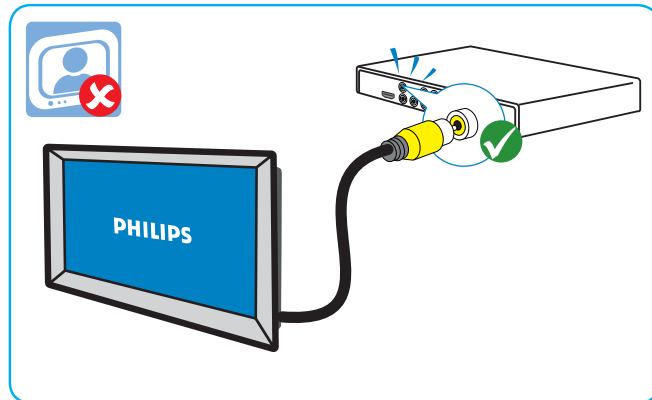
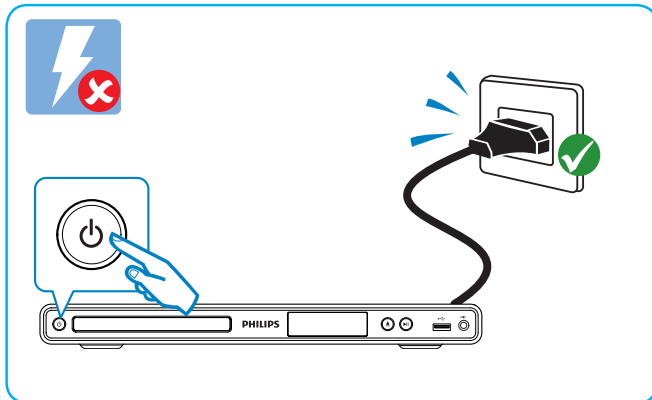
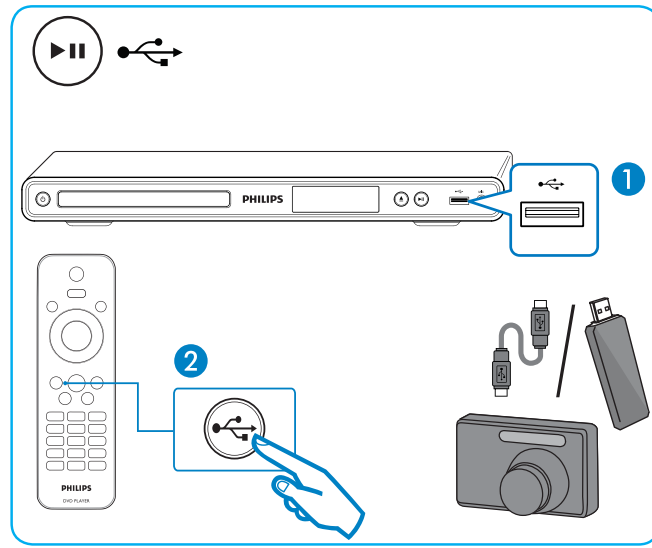
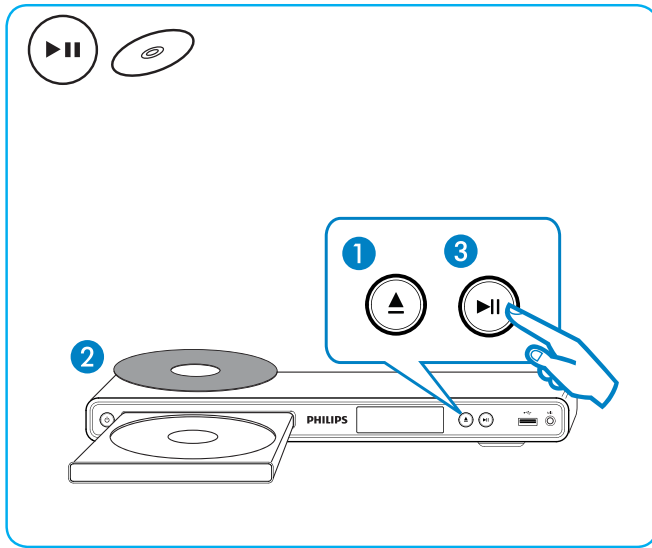

Register your product and get support at www.philips.com/welcome

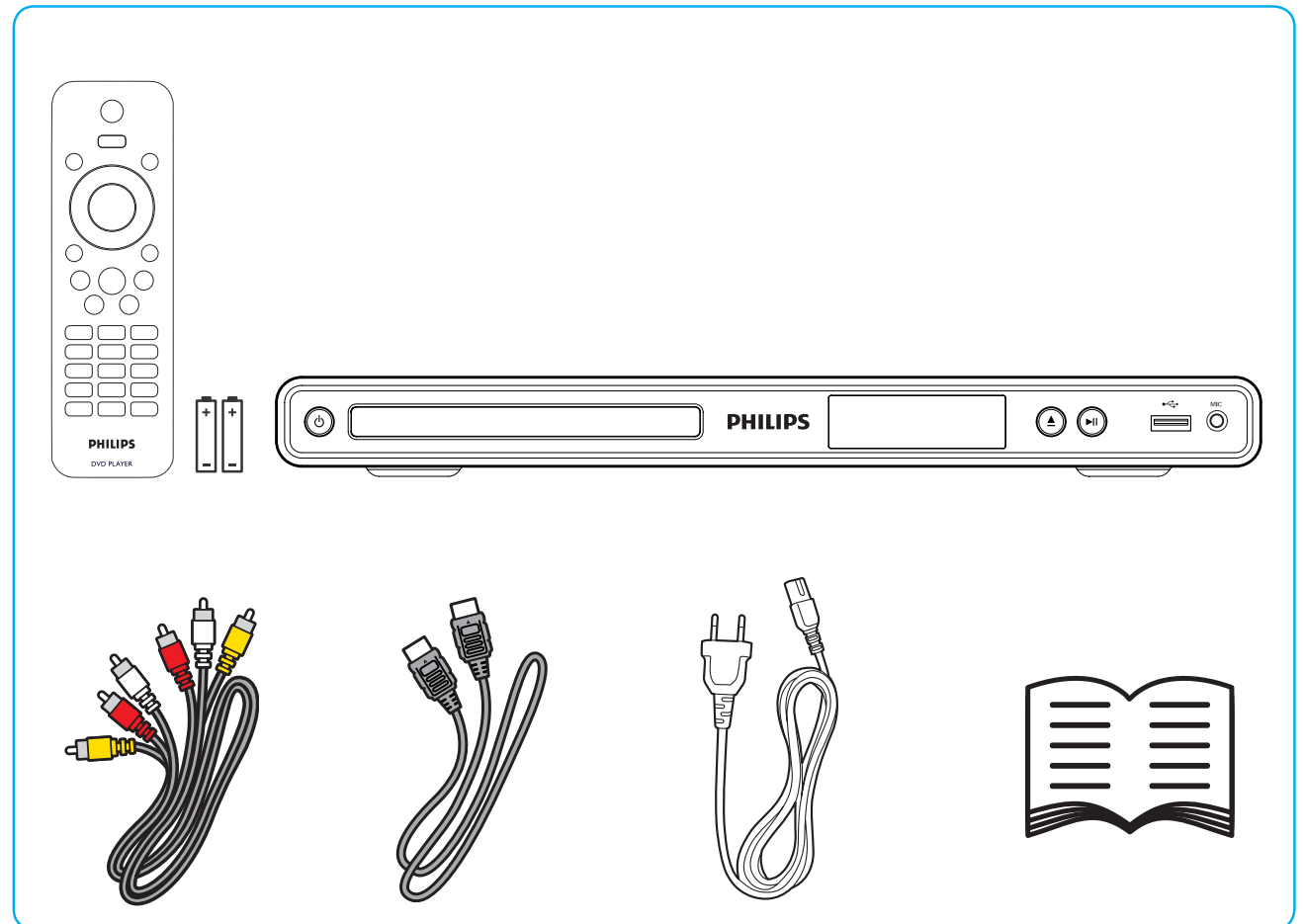

Register your product and get support at
www.philips.com/welcome

DVP3360K

3

The following excerpt of the Quick Start Guide serves as an introduction to the set. The complete Direction For Use can be downloaded in different languages from Philips Customer Contact & Support site: www.p4c.philips.com

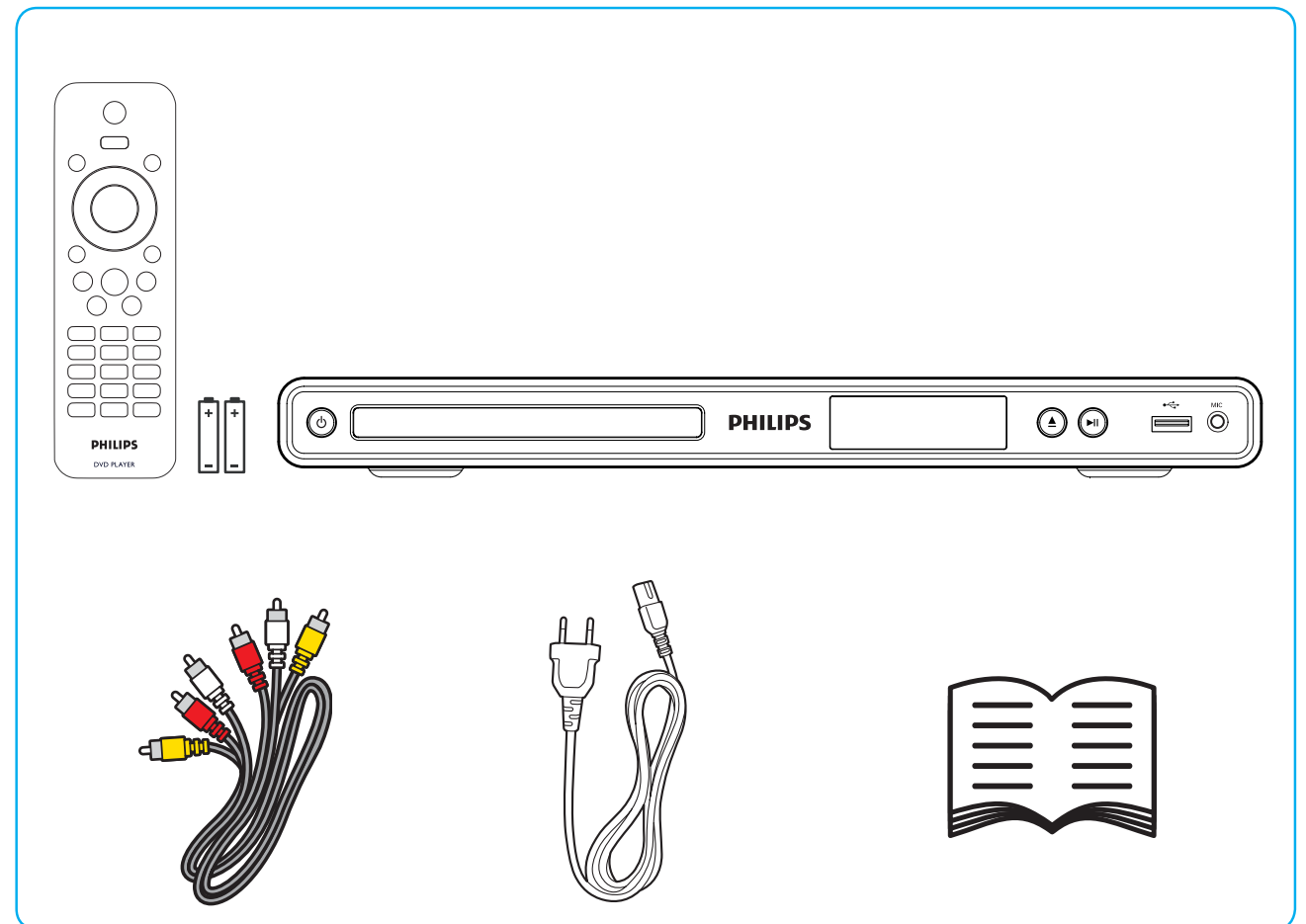
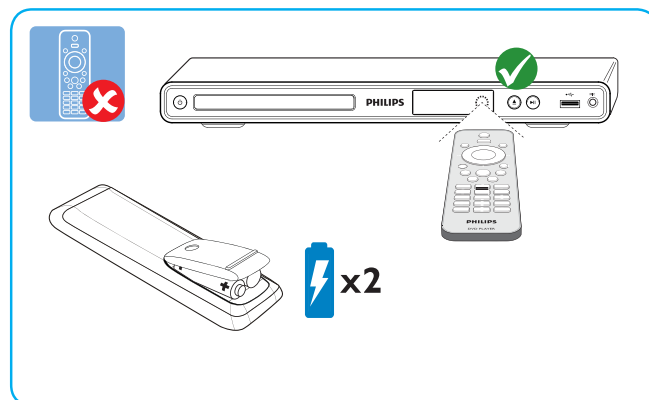
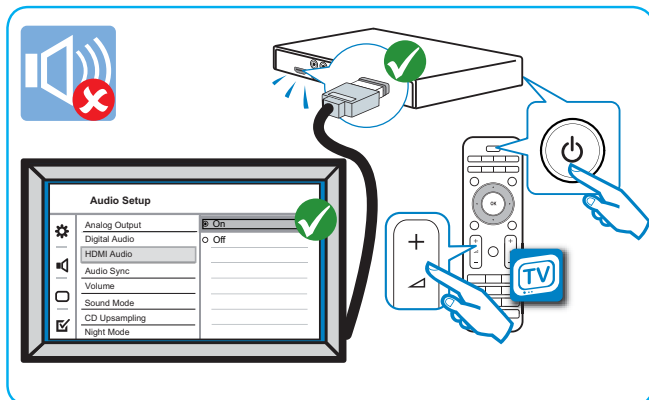
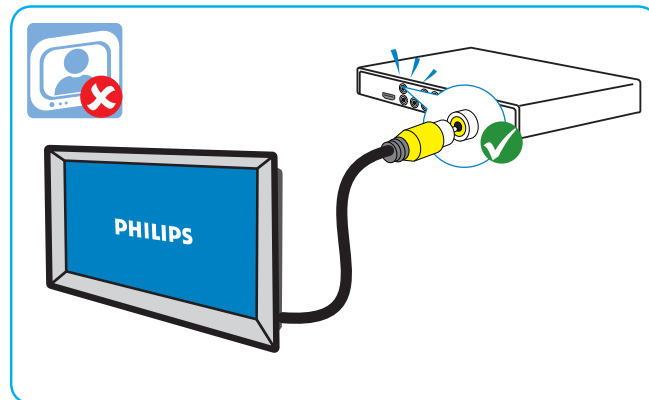
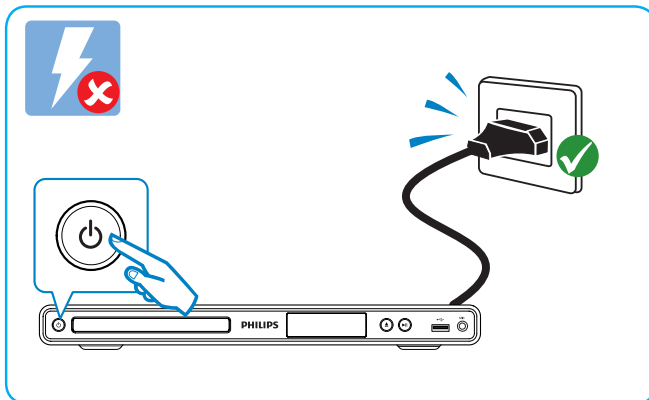
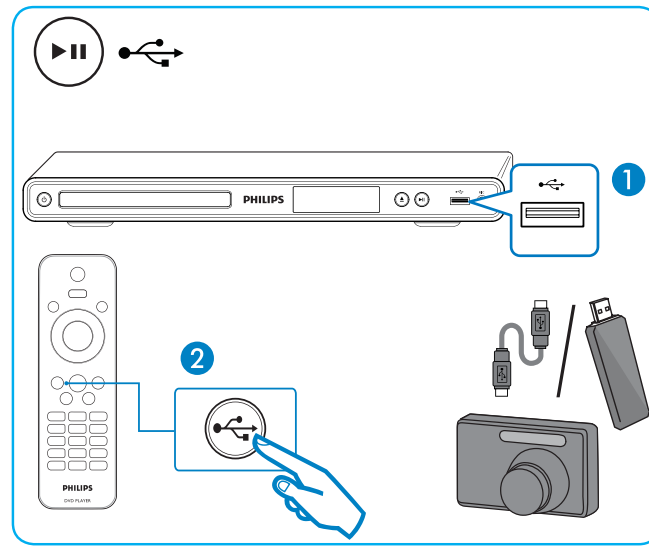
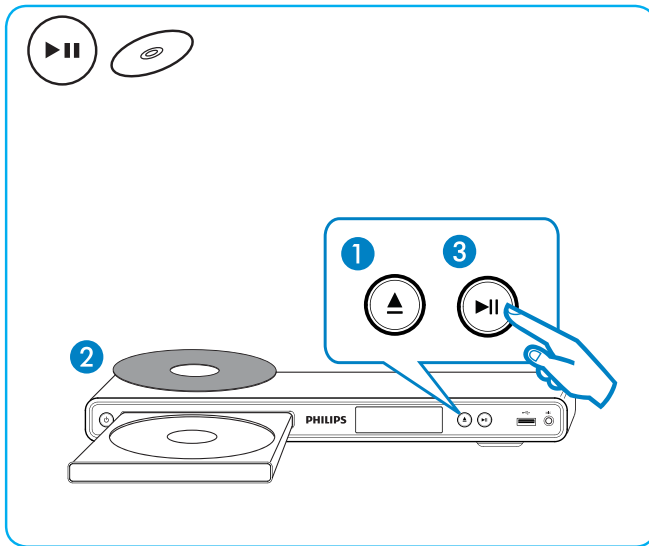

1

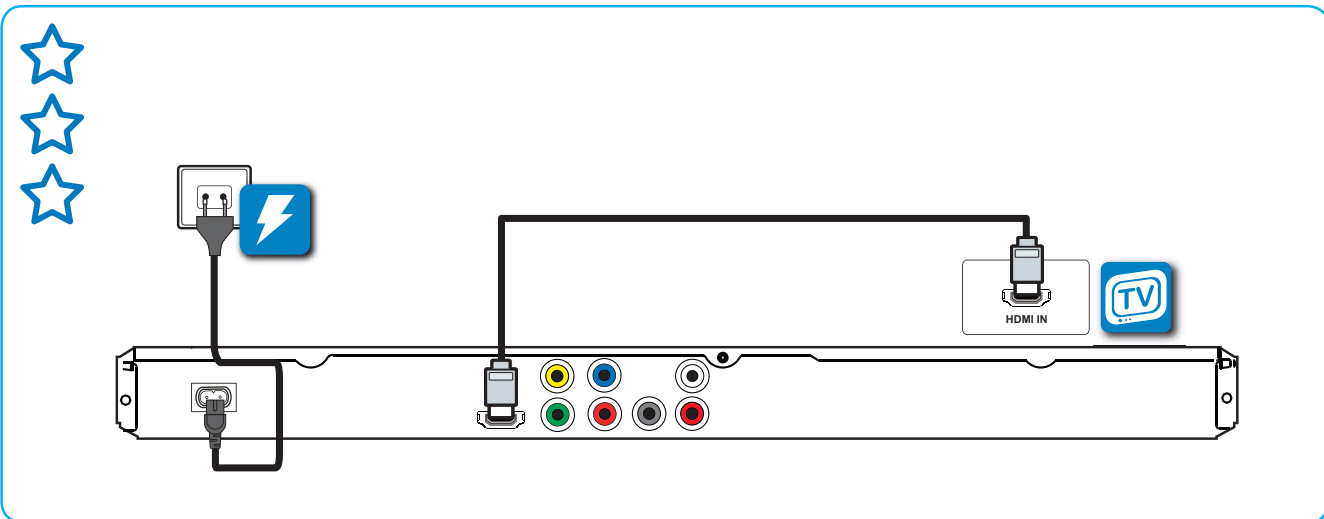
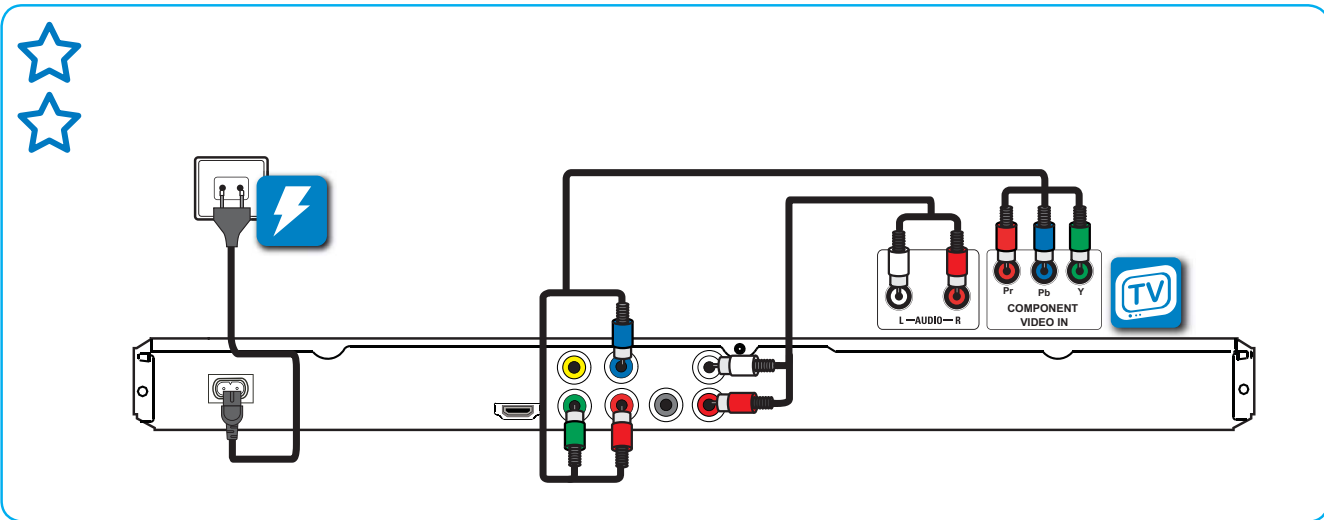
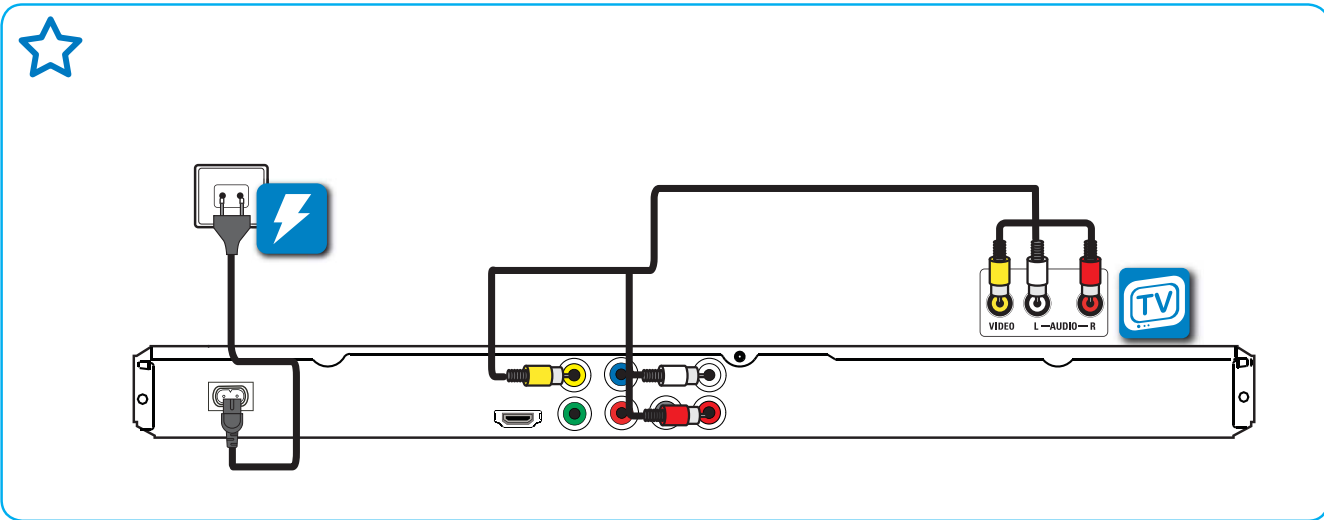

2

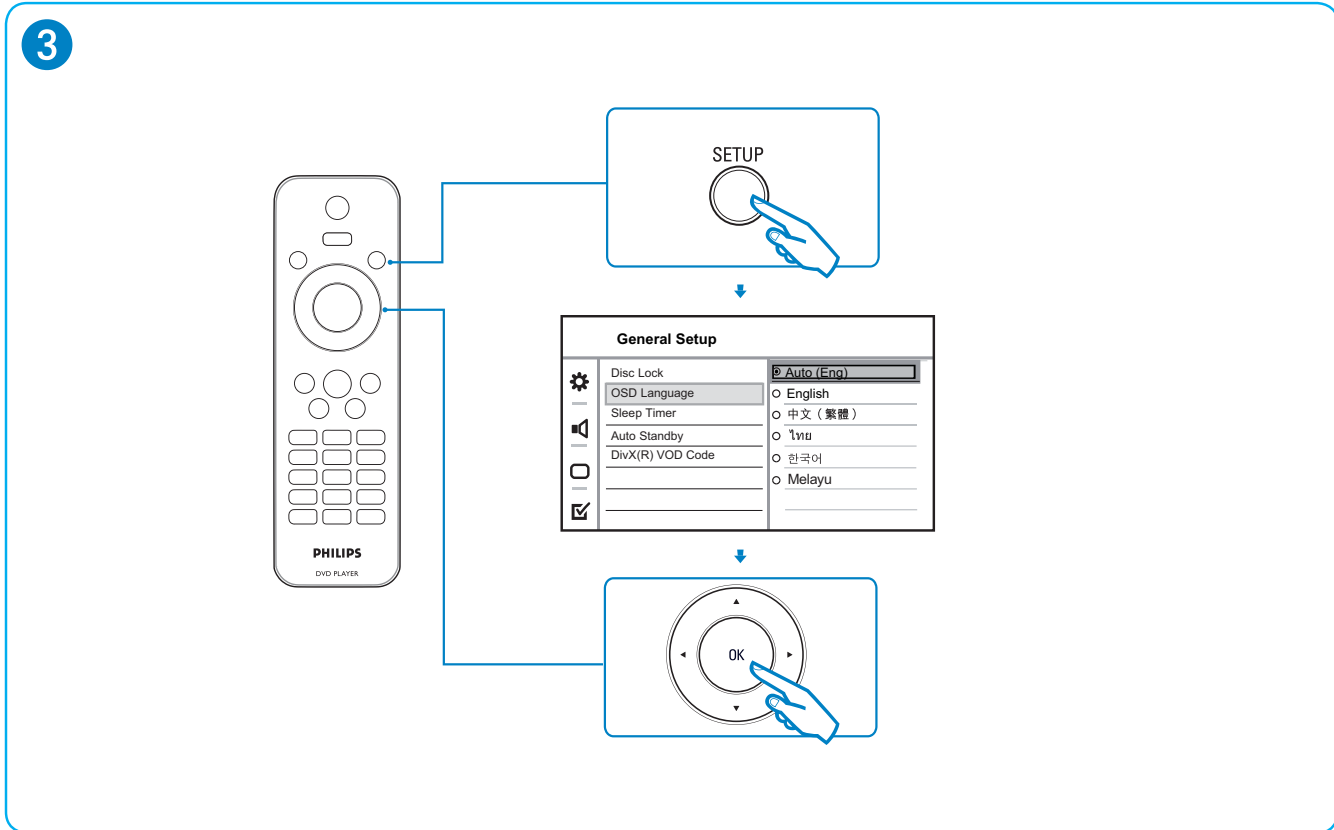
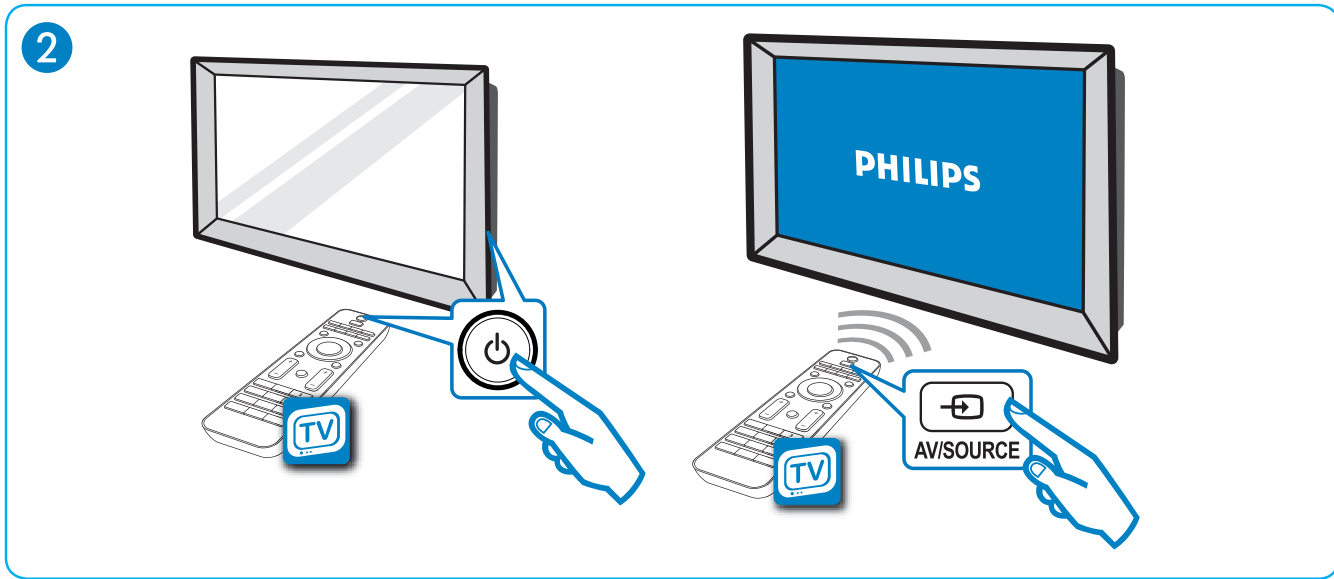
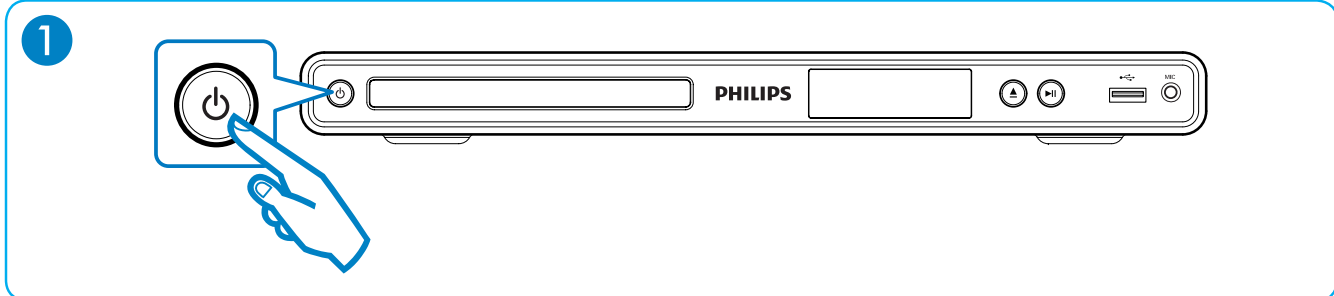

Register your product and get support at
www.philips.com/welcome

DVP3360K

3

The following excerpt of the Quick Start Guide serves as an introduction to the set. The complete Direction For Use can be download in different languages from Philips Customer Contact & Support site: www.p4c.philips.com

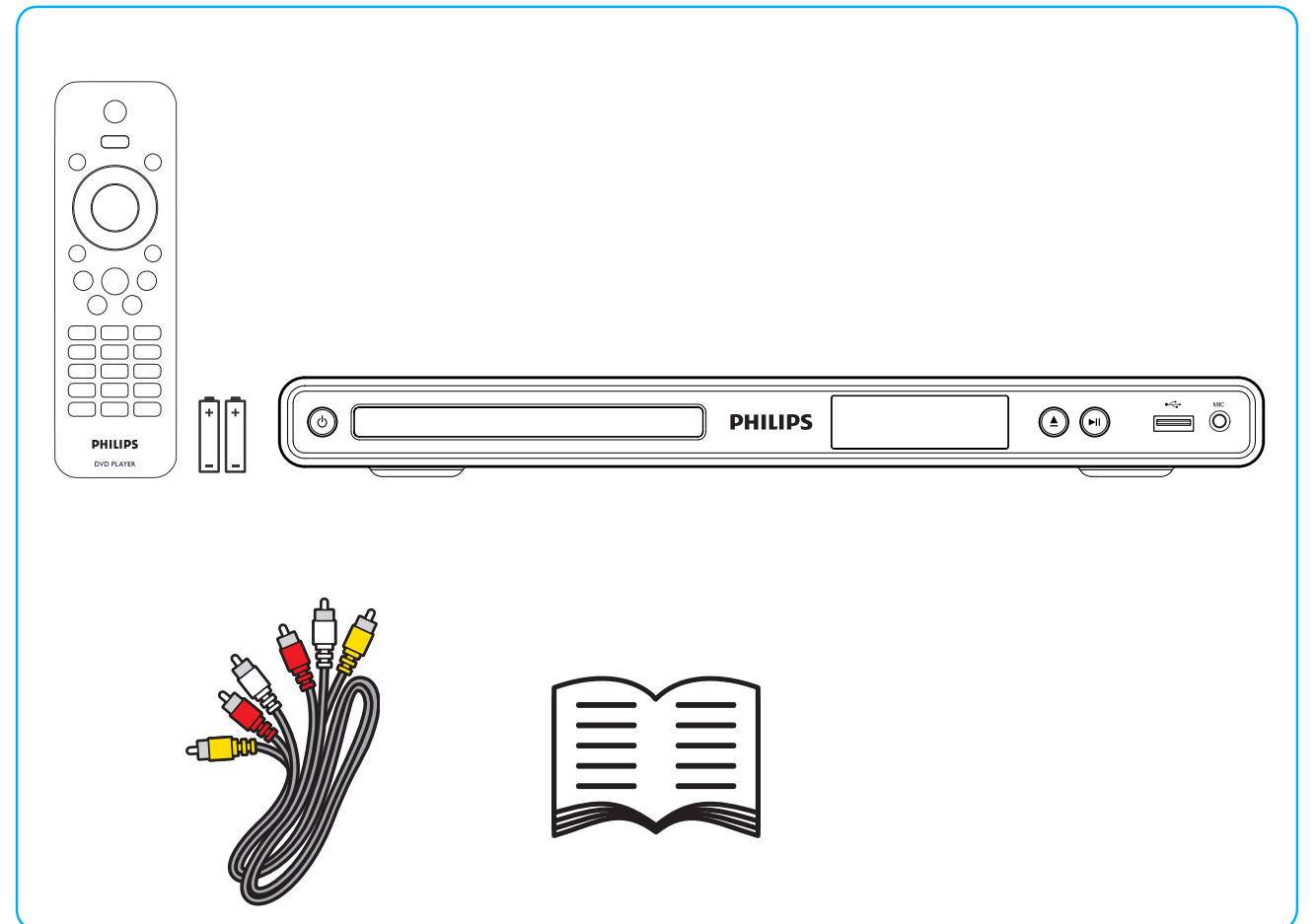
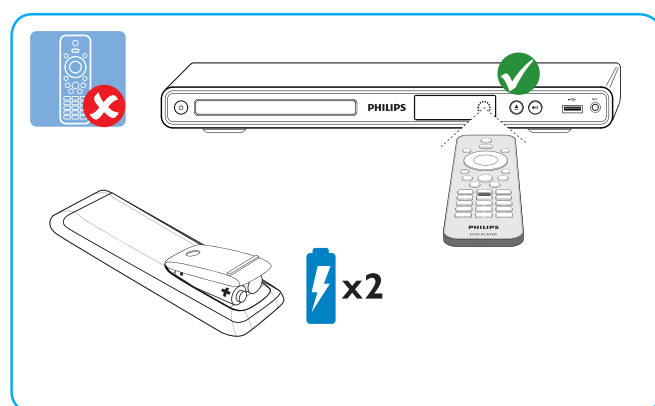
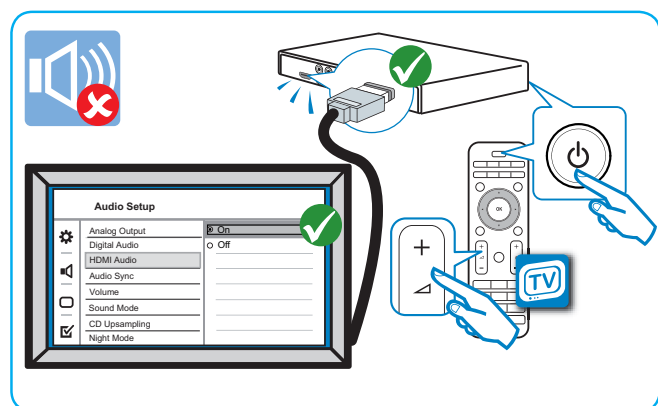
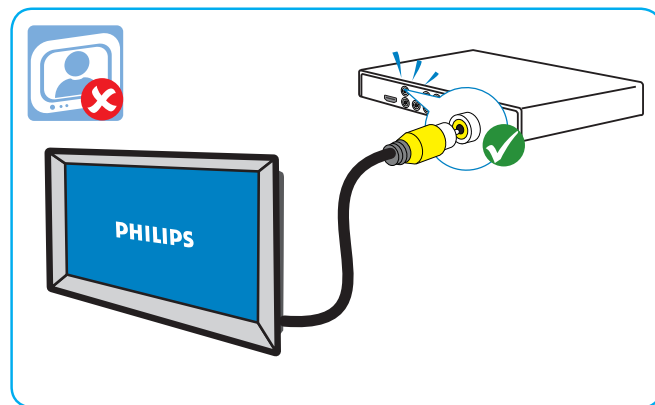
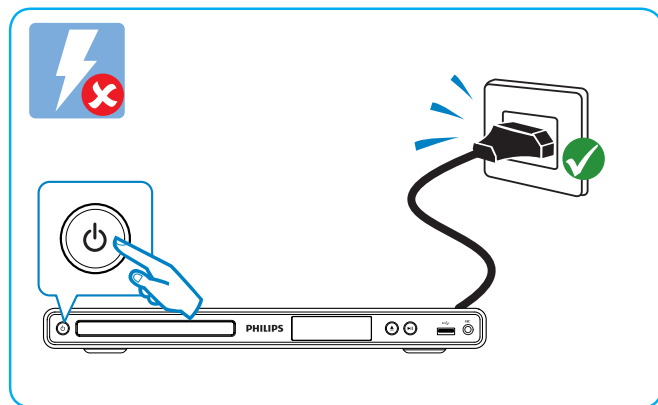
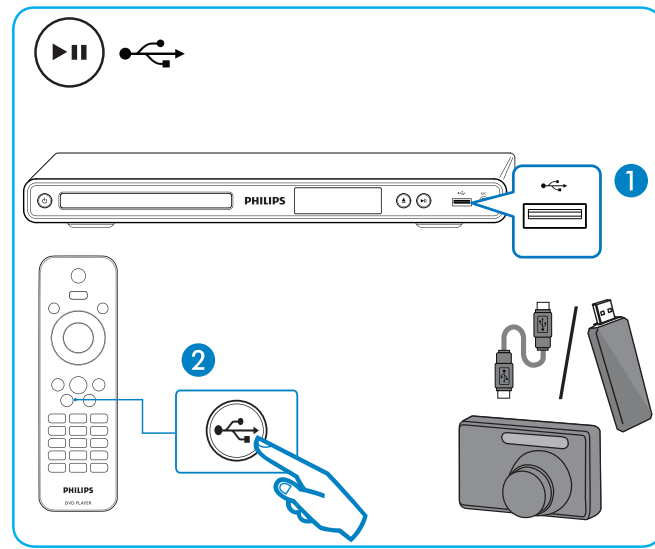
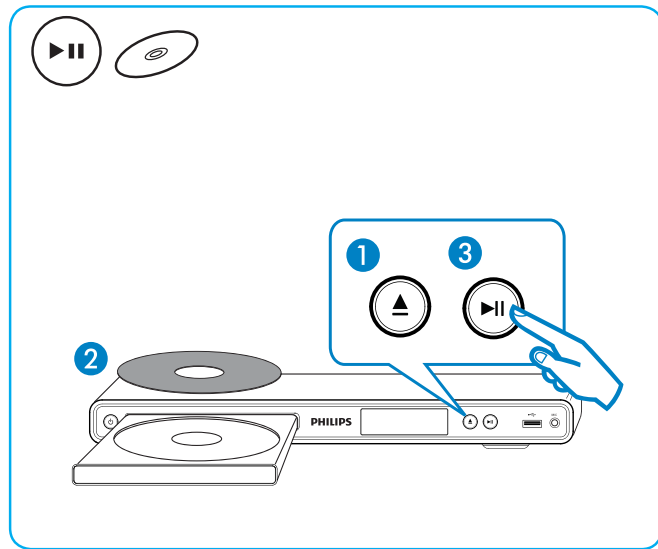

1

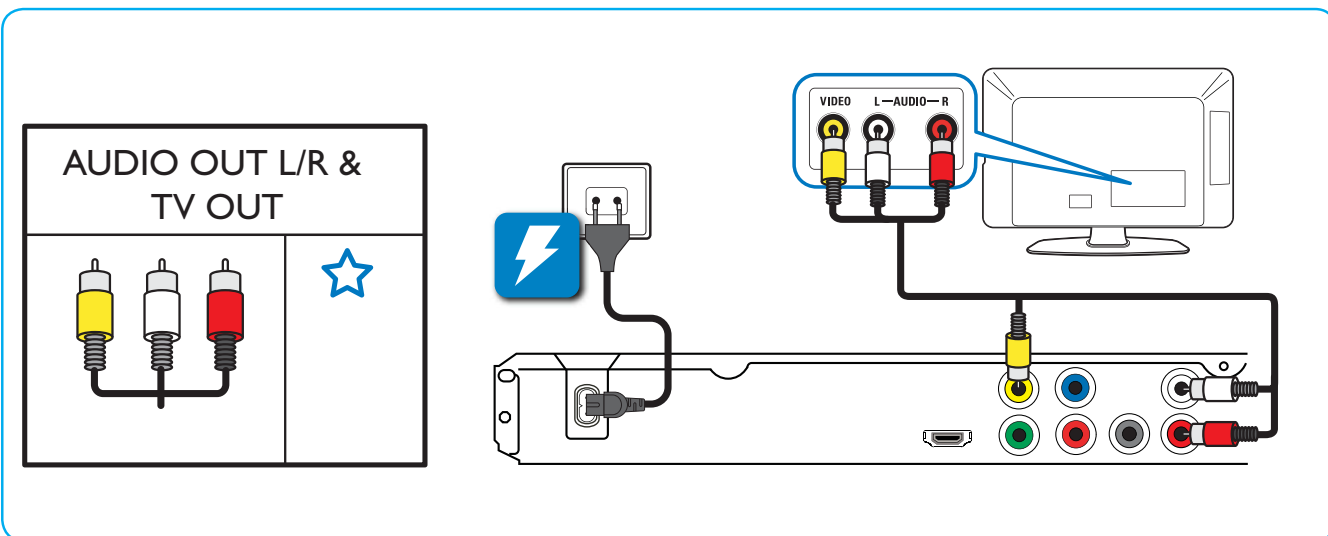
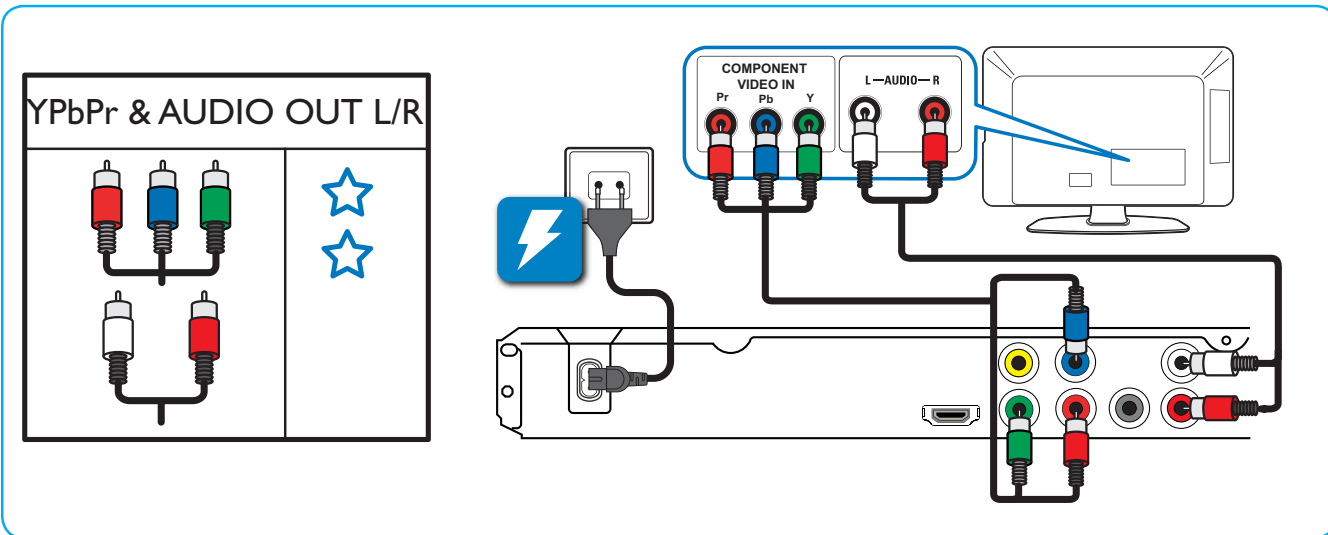
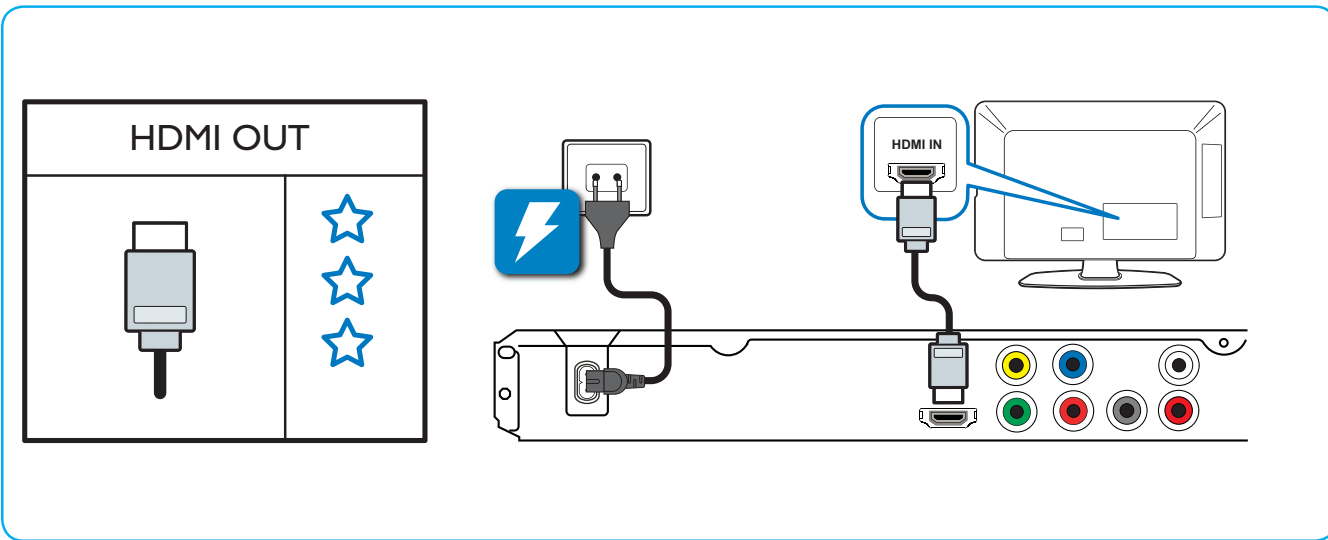



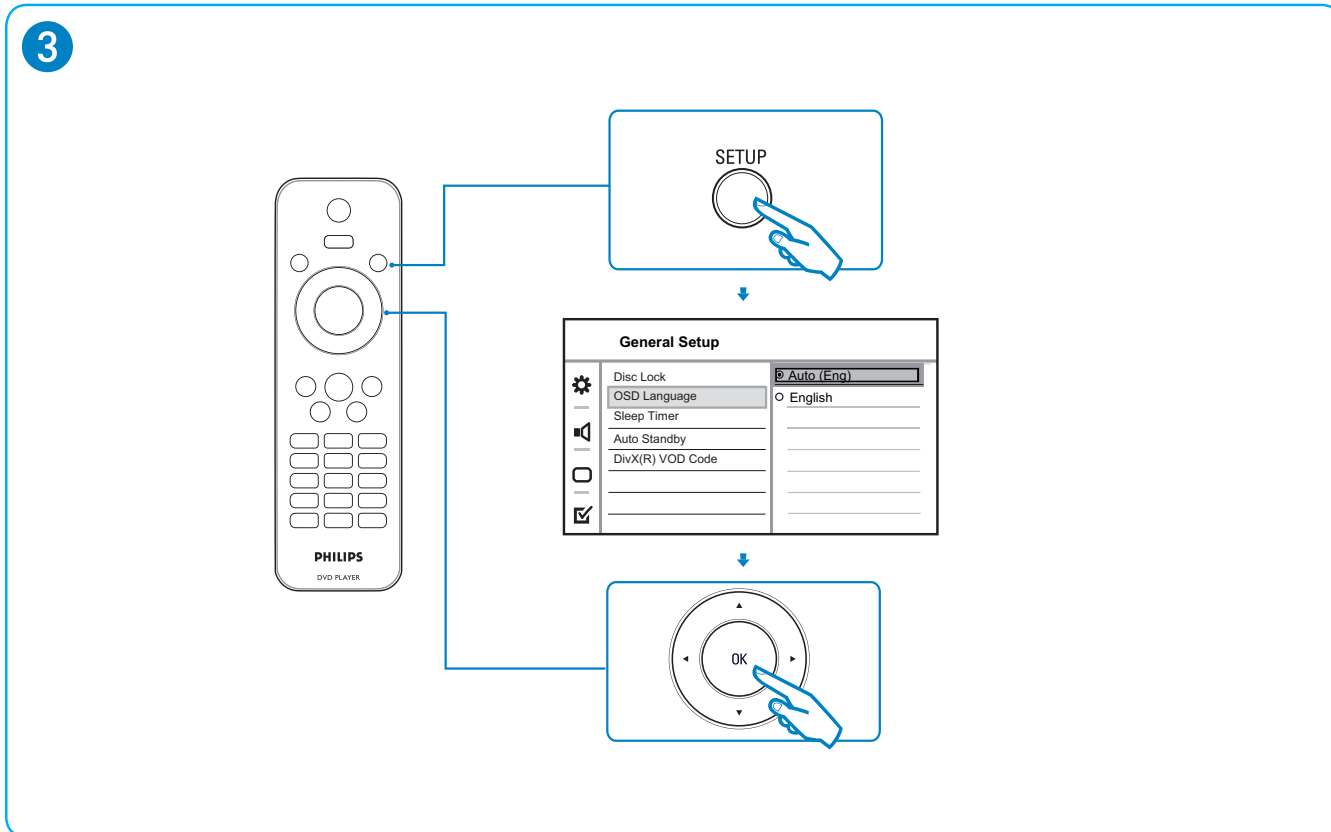
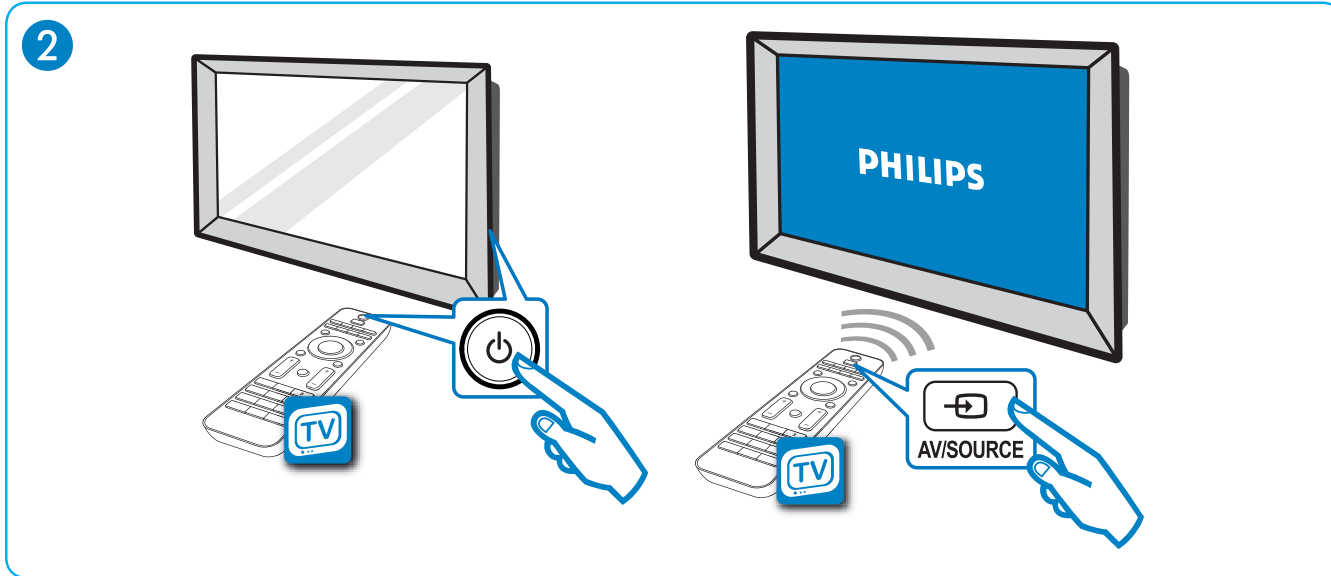
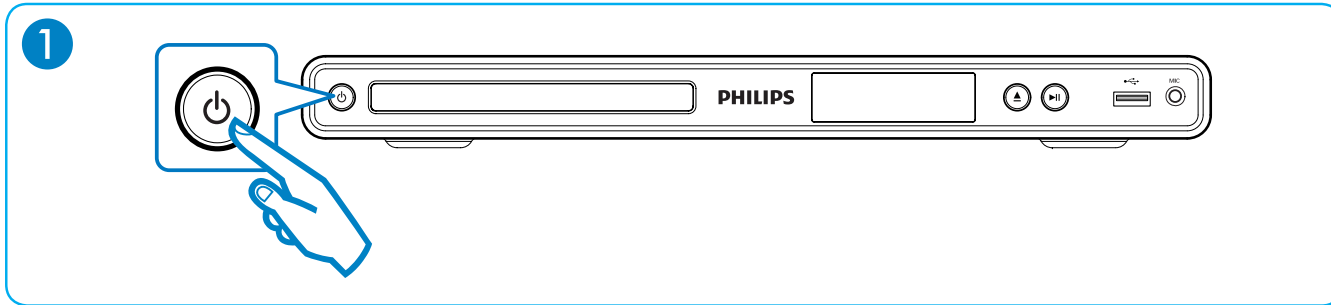

2

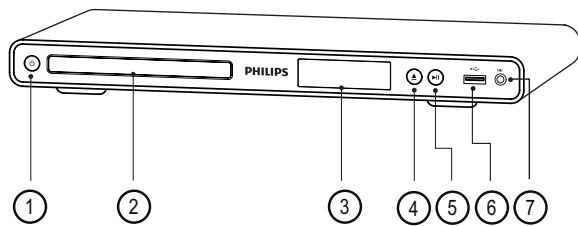

Product overview



Main unit





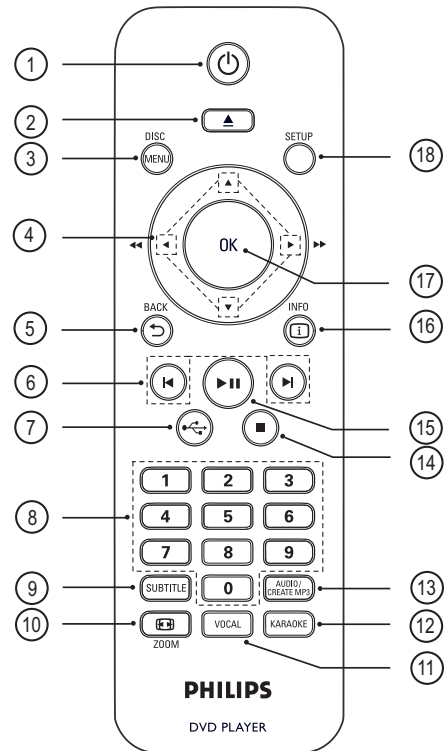

- ①  (Standby-on)
 - Turn on the DVD player or switch to standby mode.
- ② **Disc compartment**
- ③ **Display panel**
- ④  (Open/Close)
 - Open or close the disc compartment.
- ⑤  (Play/Pause)
 - Start, pause or resume disc play.
- ⑥  **(USB) jack**
 - Connect a USB flash drive.
- ⑦ **MIC**
 - Audio input from a microphone.

Remote control



- ①  (Standby-On)
 - Turn on the DVD player or switch to standby mode.
- ②  (Open/Close)
 - Open or close the disc compartment.
- ③ **DISC MENU**
 - Access or exit the disc menu.
 - Switch to disc mode.
 - For VCD/SVCD, turn PBC (Playback Control) on or off in PBC mode.

- ④ ▲▼◀▶ (Navigation buttons)
- Navigate through the menus.
 - Search fast-forward (▶) or fast-backward (◀). Press repeatedly to change the search speed.
 - Search slow-forward (▲) or slow-backward (▼). Press repeatedly to change the search speed.
- ⑤ ↶ **BACK**
- Return to the previous display menu.
 - For DVD, navigate to the title menu.
 - For VCD version 2.0 or SVCD with PBC turned on, return to the menu.
- ⑥ ◀/▶ (Previous/Next)
- Skip to the previous or next title, chapter, or track.
 - Press and hold for fast-backward or fast-forward search.
- ⑦  (USB)
- Switch to USB mode and display the content.
- ⑧ **Numeric buttons**
- Select an item to play.
- ⑨ **SUBTITLE**
- Select DVD or DivX subtitle language.
- ⑩  **ZOOM**
- Fit the picture format to the TV screen.
 - Zoom in or out of the picture.
- ⑪ **VOCAL**
- Change the audio channel of a karaoke disc.
- ⑫ **KARAOKE**
- Access or exit the karaoke menu.
- ⑬ **AUDIO/CREATE MP3**
- Select an audio language/channel.
 - Access the menu to create MP3.
- ⑭  (Stop)
- Stop disc play.
- ⑮  (Play/Pause)
- Start, pause or resume disc play.
- ⑯  **INFO**
- For disc, display the current status or disc information.
 - For slideshows, display a thumbnail view of photo files.
- ⑰ **OK**
- Confirm an entry or selection.
- ⑱ **SETUP**
- Access or exit the setup menu.

Mechanical and Dismantling Instructions

Dismantling Instruction

Detailed information please refer to the model set.

The following guidelines show how to dismantle the player.

Step1: Remove 5 screws around the Top Cover, and then remove the Top Cover (Figure 1).



Figure 1

Step2: If it is necessary to dismantle Loader or Front Panel, the Front door should be removed first. (Figure 2)

Note: Make sure to operate gently otherwise the guider would be damaged.



Please kindly note that dismantle the front door assembly carefully to avoid damage tray and the front door.

Figure 2

Mechanical and Dismantling Instructions

Dismantling Instruction

Detailed information please refer to the model set.

Step3: If the tray can't open in normal way, you can make it through the instruction as below (Figure 3).

Note: Make sure to operate gently otherwise the guider would be damaged.



Figure 3

Step4: Dismantling Front Panel, disconnect the connectors (XP5, XP6, XP7), need release 4 snaps of Front Panel and 2 snaps of bottom cabinet, then gently pull the Panel out from the set. (Figure 4 - Figure 6)

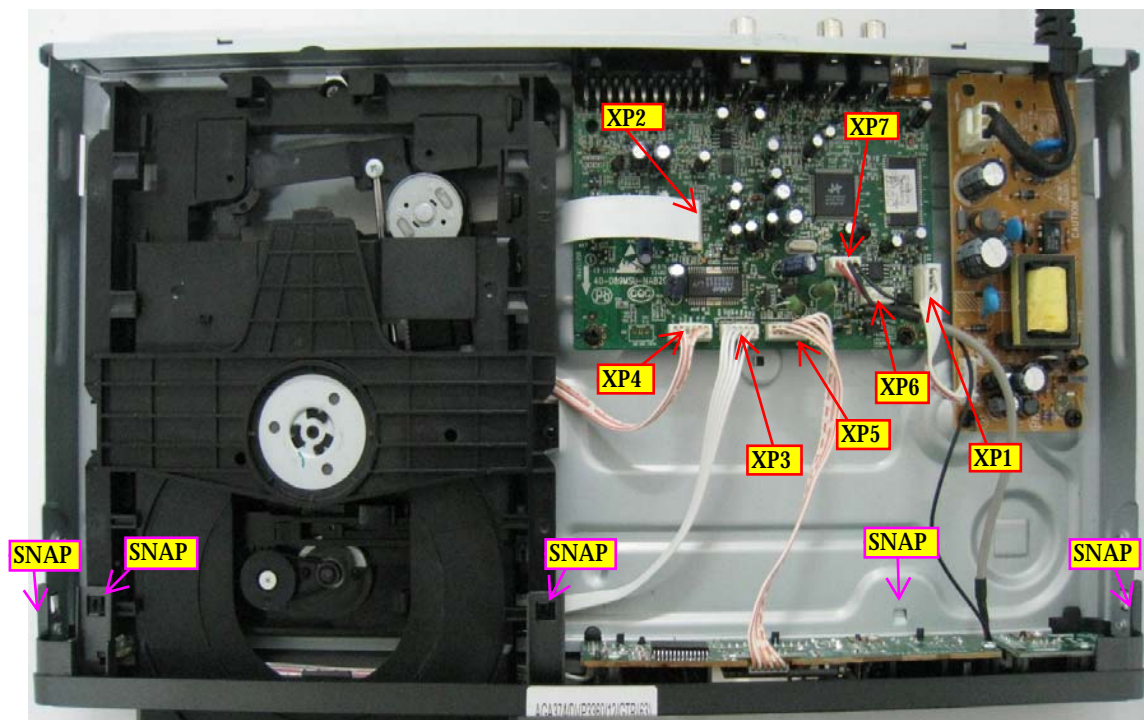

Figure 4

Mechanical and Dismantling Instructions

Dismantling Instruction

Detailed information please refer to the model set.

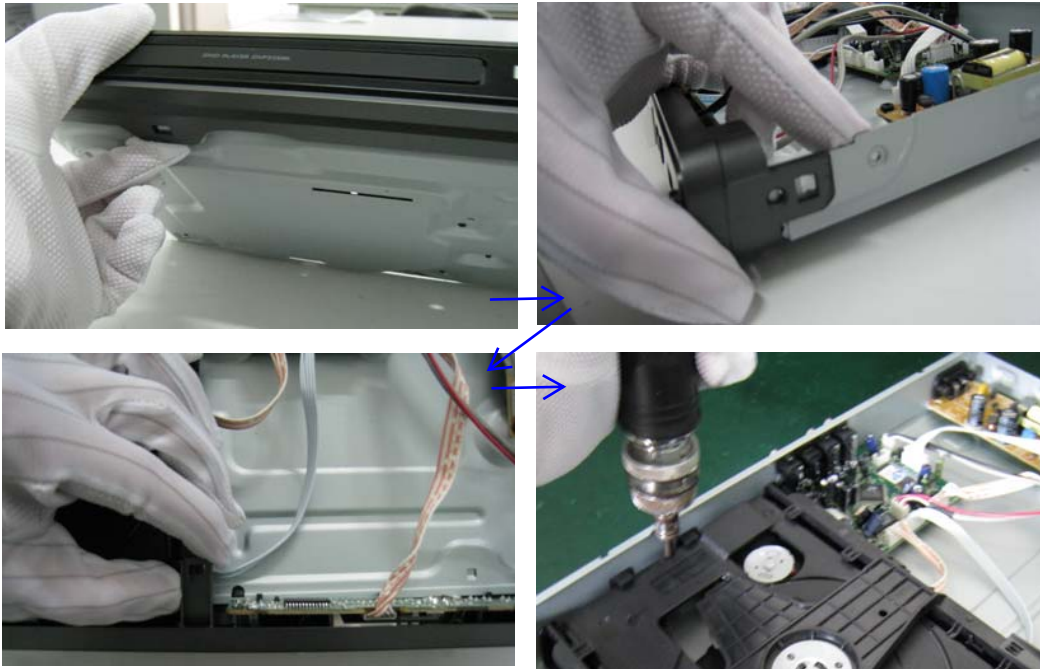

Figure 5

Step5: Dismantling Loader, disconnect the 3 connectors (XP2, XP3, XP4) aiming in the below figure, and remove 1 screw that connects the loader and the bottom cabinet. (Figure 5 & 6)

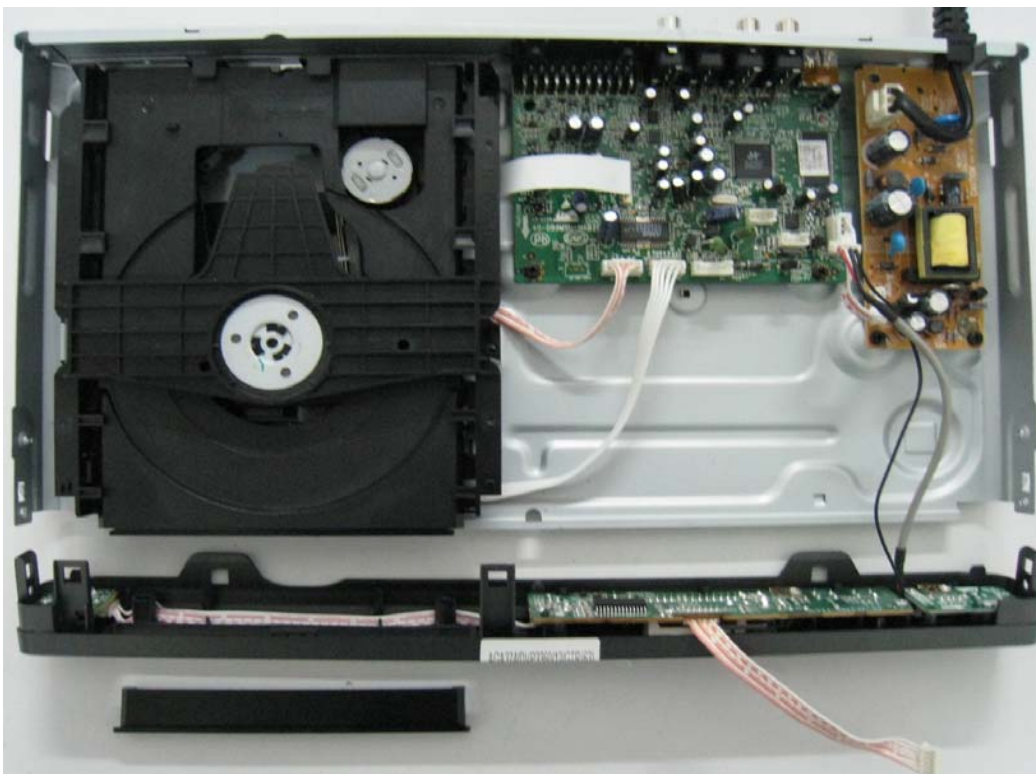

Figure 6

Mechanical and Dismantling Instructions

Dismantling Instruction

Detailed information please refer to the model set.

Step6: Dismantling Main Board, first disconnect the connector (XP1), and then remove 5 screws. (Figure 7)

Step7: Remove the 2 screws on Power Board to dismantle the Power Board. (Figure 7)

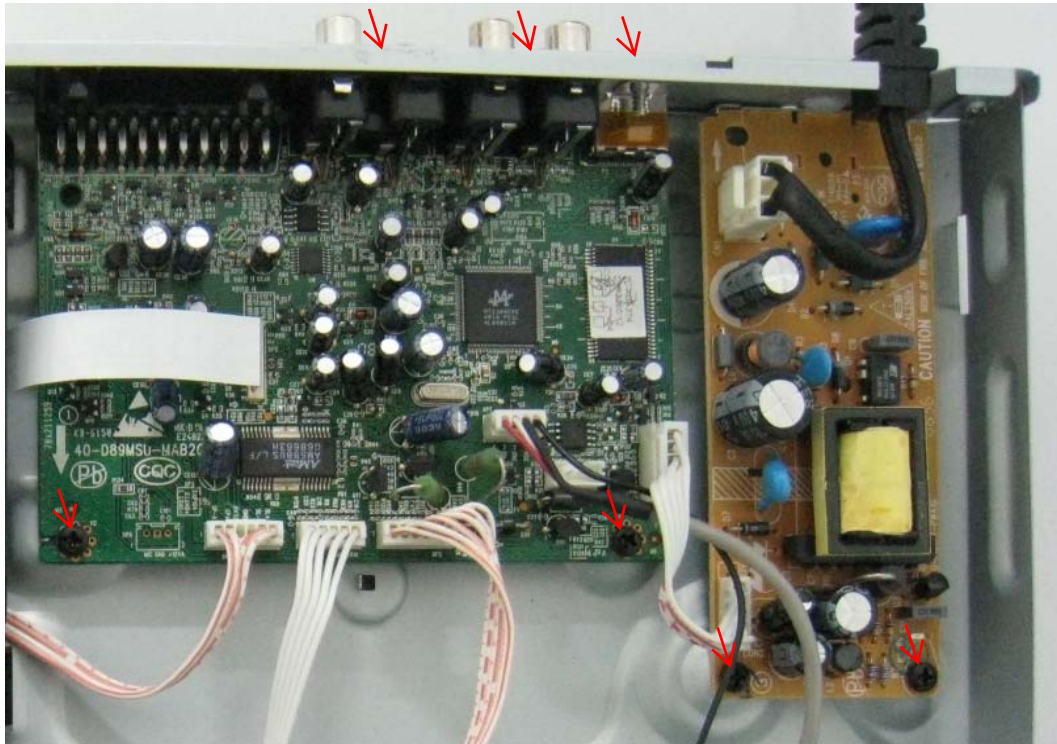

Figure 7

Software upgrade

Preparation to upgrade software *

- 1) Start the CD Burning software and create a new CD project (Data Disc) with the following setting:
Label: DVP3XXXX (No need the label name)
File Name: DVPXXXXX_XX.BIN
Power on the set and open the tray, then press <5><5> to check the File Name.

Note: It is required capital letter for the File System name.

- 2) Burn the data onto a blank CDR

A. Procedure for software upgrade:

- 1) Power on the set and insert the prepared Upgrade CDR.
- 2) The set will starts reading disc & response with the following display TV screen:
Upgrade File DETECTED
Upgrade?
Press Play TO START.
- 3) Press <OK> button to confirm, then screen will display :
Files coping...
UPGRADING...
- 4) The upgraded tray will automatically open when files coping complete, then take out the disc.
- 5) About 1 minute later, the trace will automatically close when upgrading complete.

B. Read out the software versions to confirm upgrading

- 1) Power on the set and press <Setup> button on the remote control.
- 2) Press<1><3><7><9> button or press down cursor on remote control to choose "Preference" and press right & down cursors to choose "Version Info".

The software version and other information are display on the TV screen as follows:

Model	DVP33XXX XX
File Name	DVP33XXX XX.BIN
Version	XX.XX.XX.XX
RISC	XX.XX.XX.XX
Servo	XX.XX.XX.XX
Region Code	X
HDCP	PASS(except press<1><3><7><9>)

* The other upgrade SW way is by memory, the steps are the same as CDR's, create the upgrade file into memory, and connect the USB flash drive to the USB socket on set, then press "USB" on remote control to access the content and play the upgrade file as above upgrade procedure.

Caution: The set must not be power off during upgrading, Otherwise the Main board will be damaged entirely.

Region Code Change

- 1) Power on the set and open the tray door;
- 2) Press the "Setup" button on the remote control, then the setup interface should be displayed on the TV screen;
- 3) Move the down cursor on remote control to choose "Reference" and press "1" "3" "8" "9" "3" "1" on the remote control;
- 4) Then move the up or down cursors to choose the region code.

Note: restart after above steps.

Spindle motor does not move

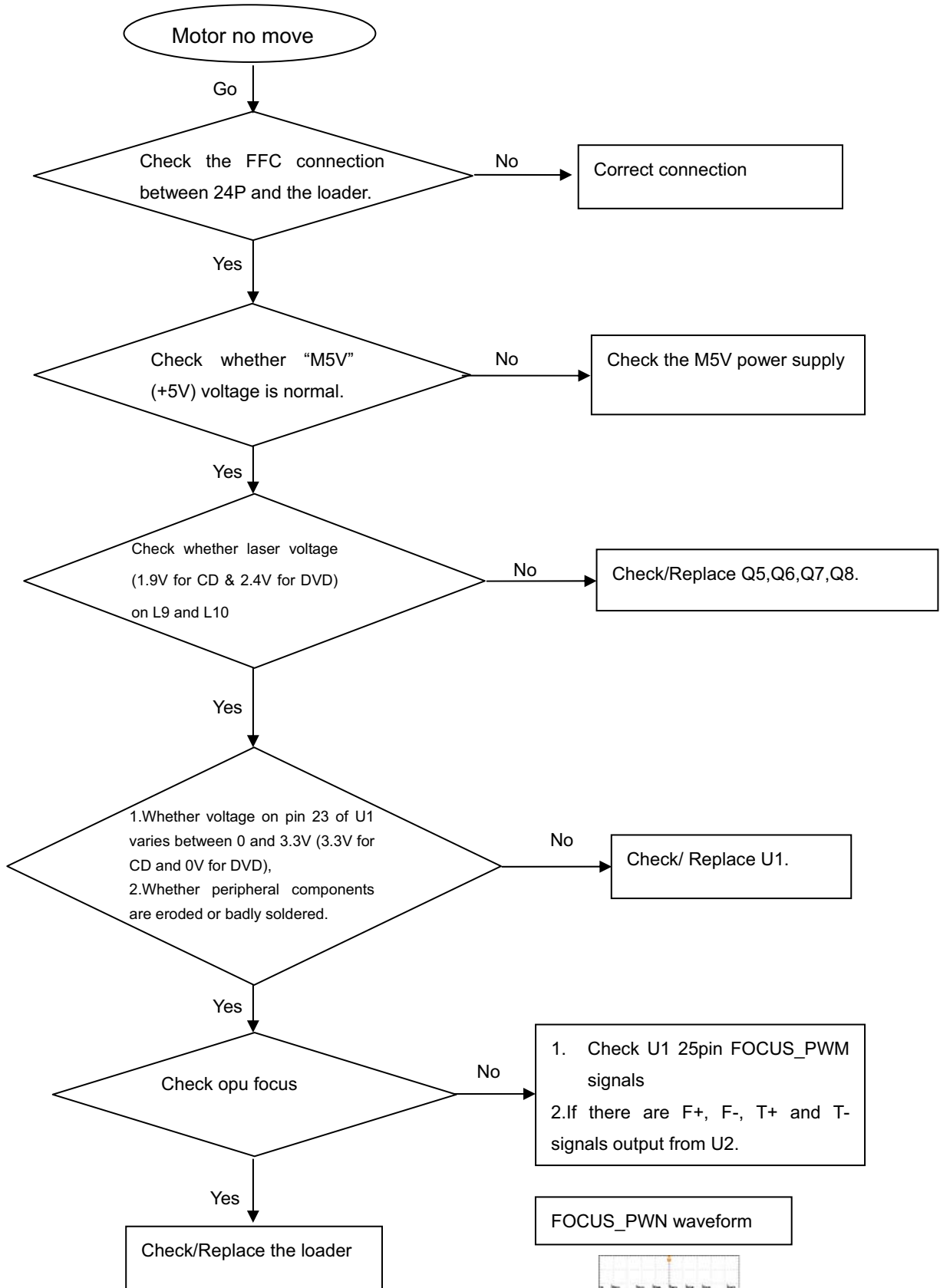

FOCUS_PWN waveform

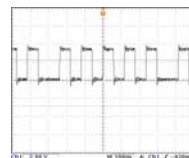

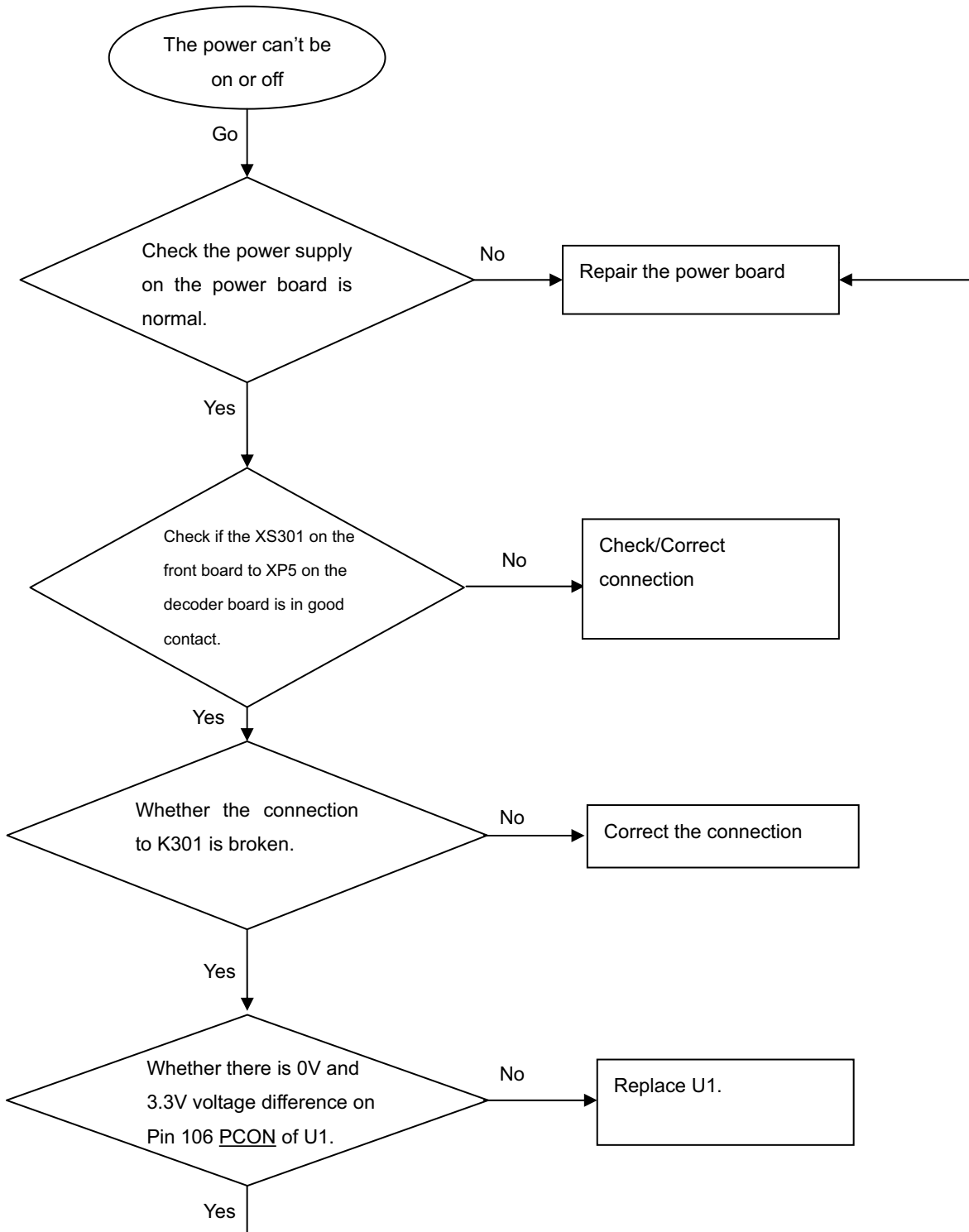
The power can not be on or off

All output voltages on the power board is 0V or deviated.

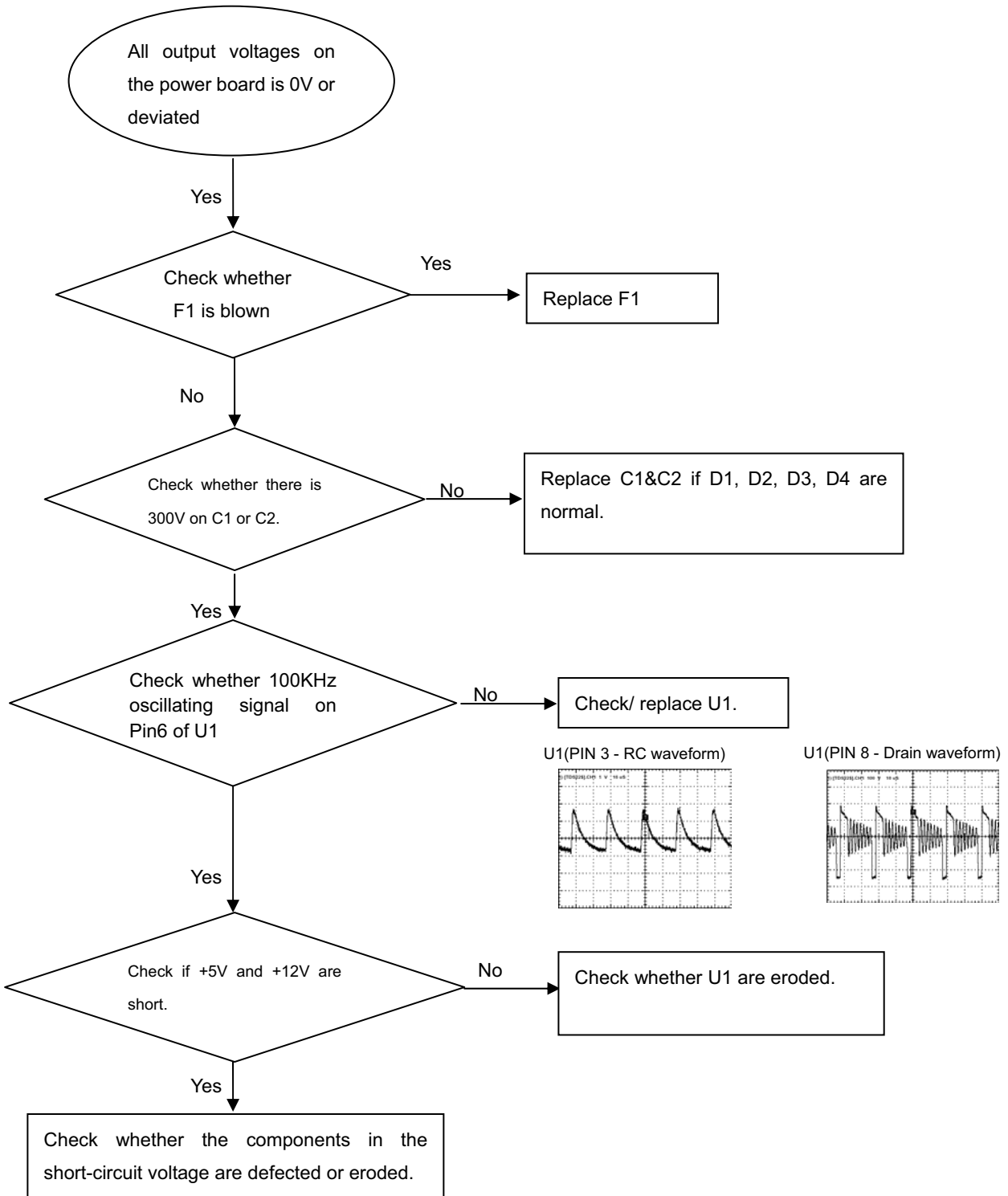

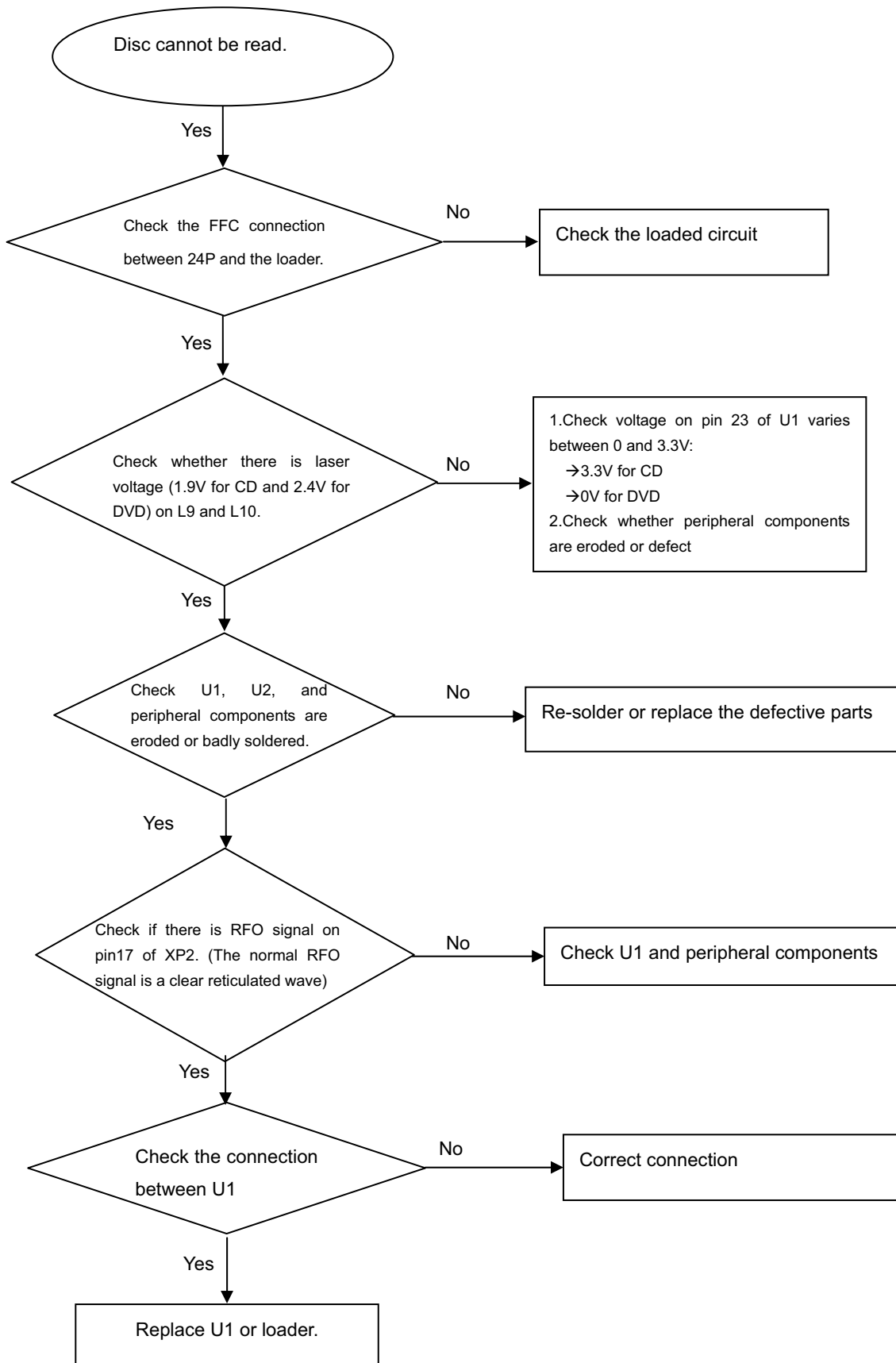
Disc cannot be read.

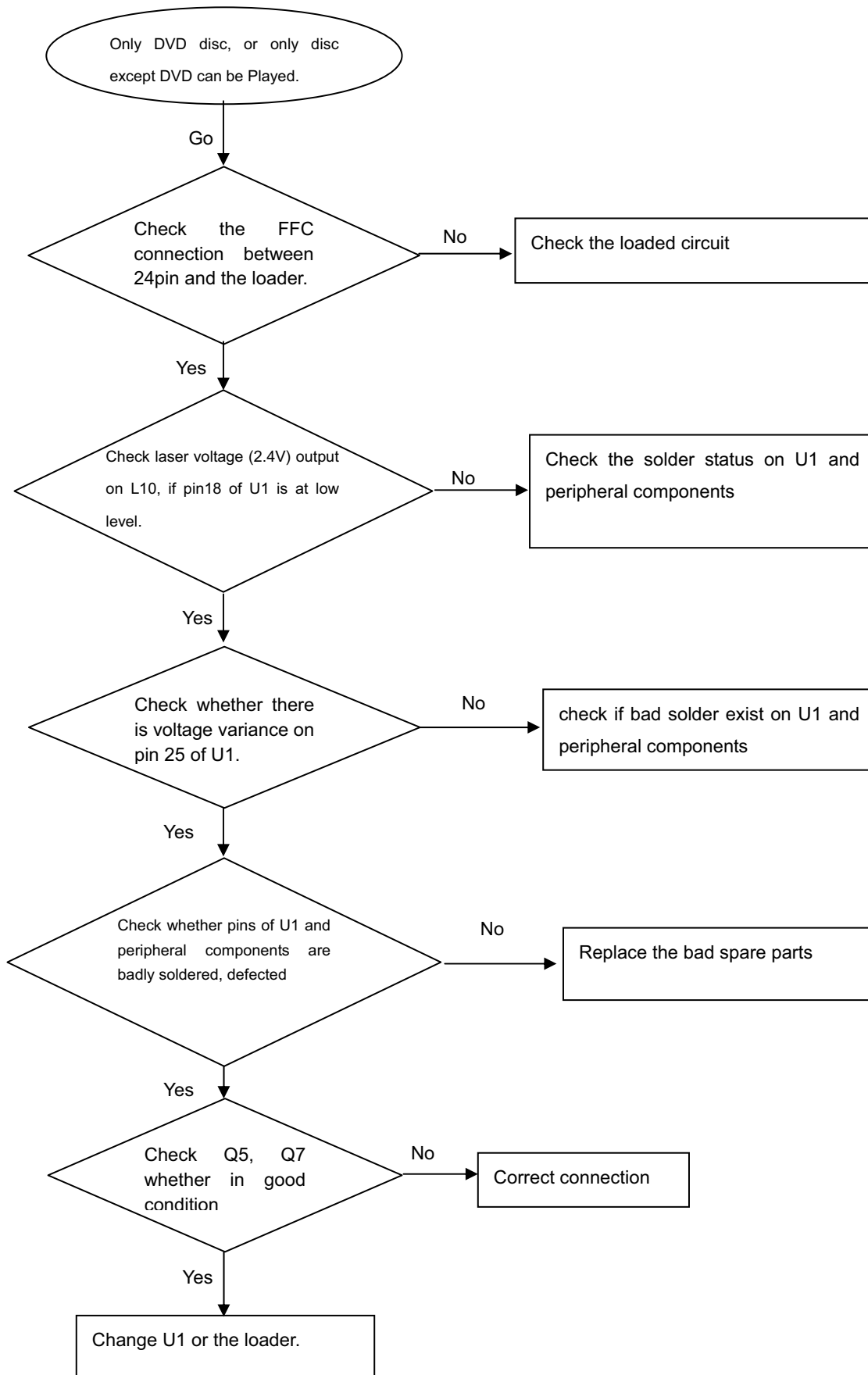
Only DVD disc or only disc except DVD can be played

No display on LED, and buttons do not work

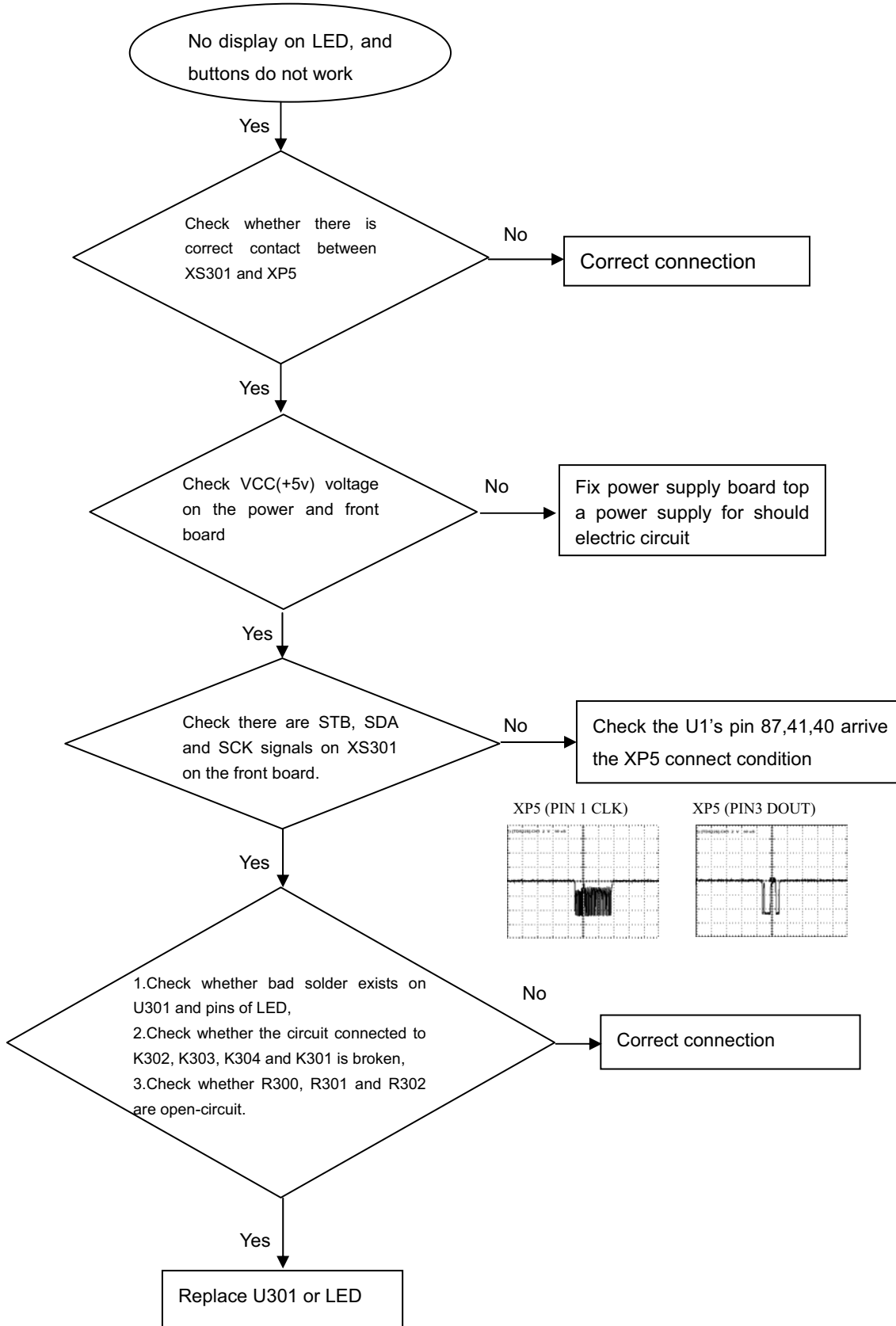

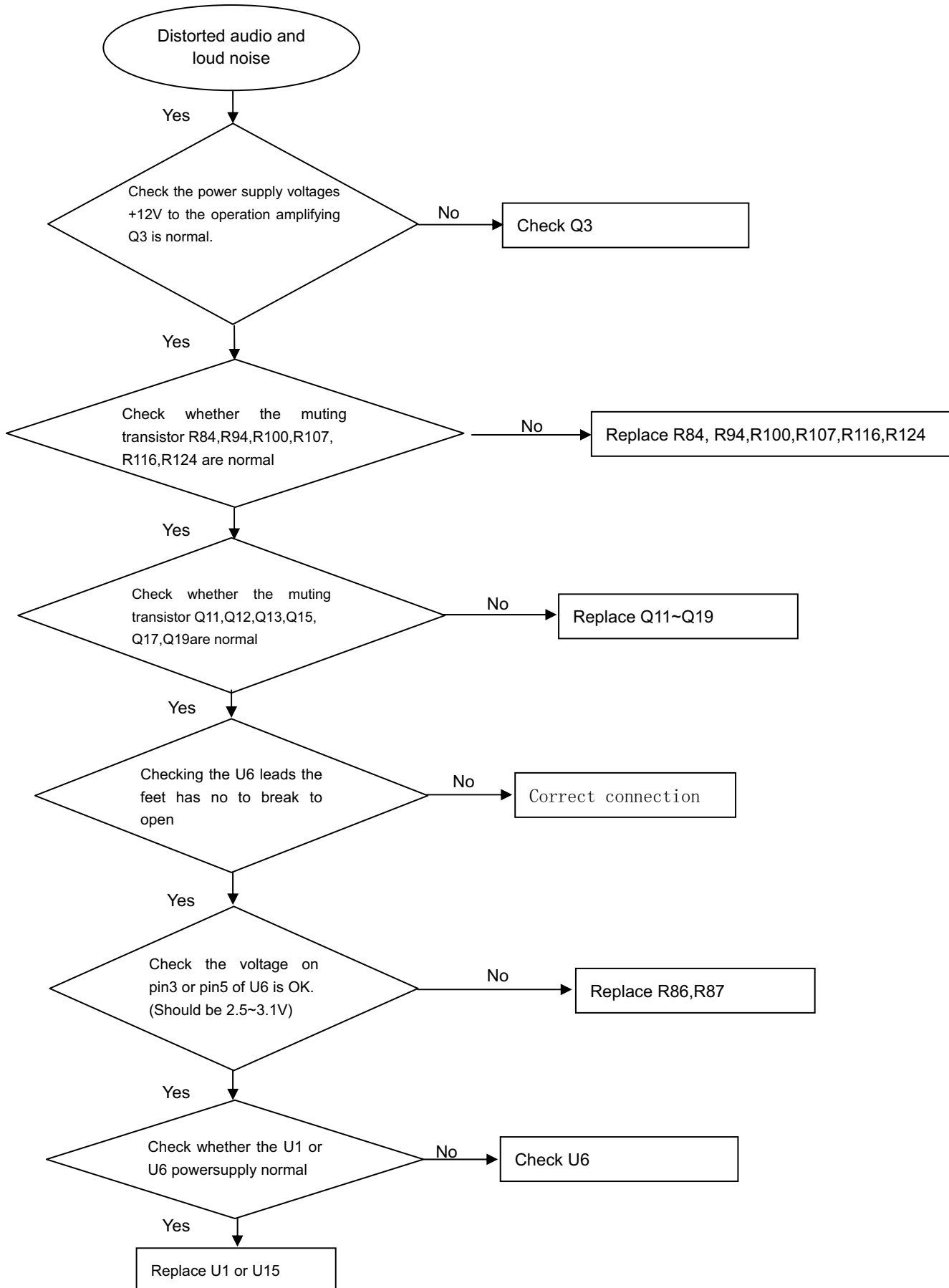
Distorted audio and loud noise

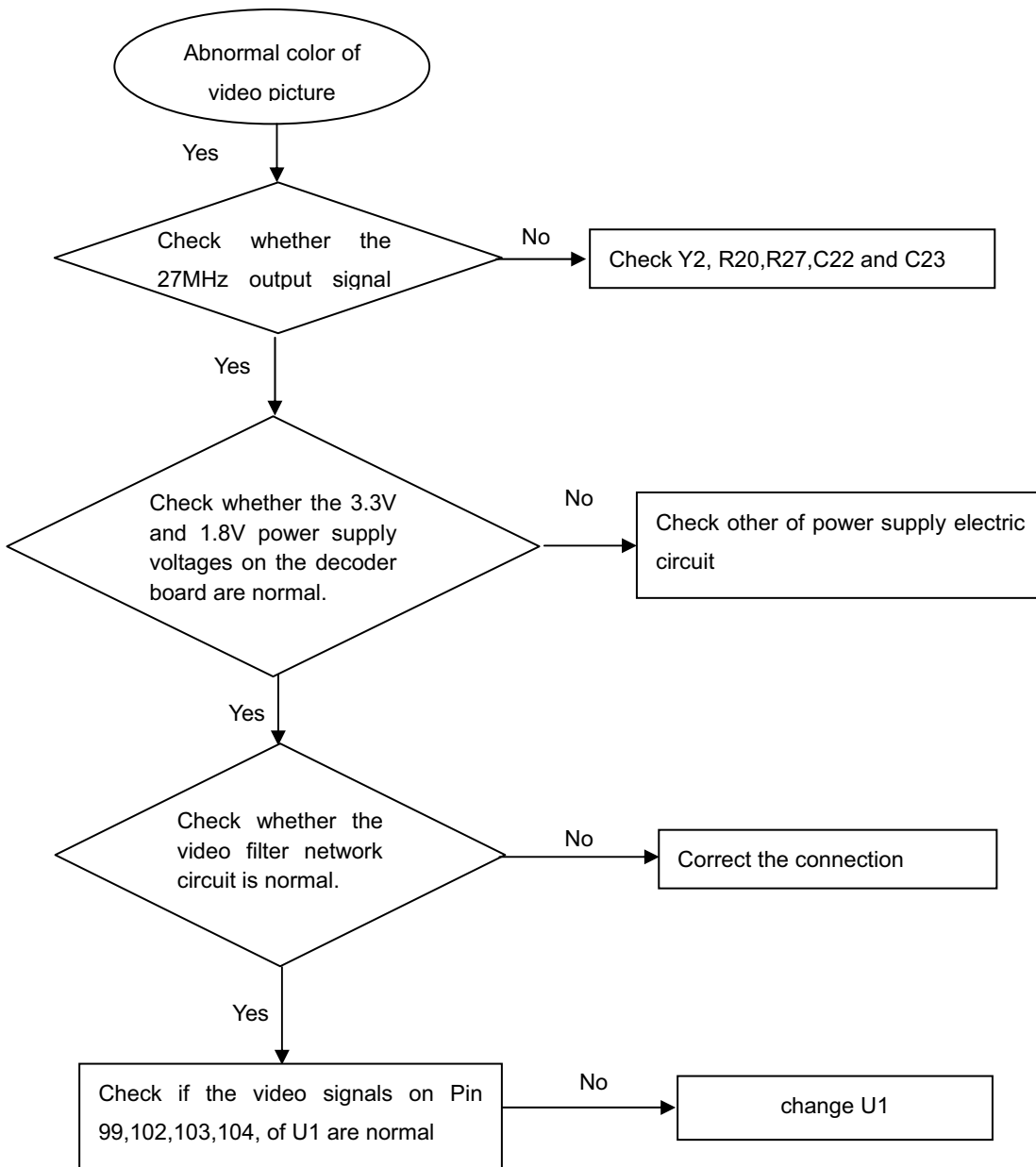
Abnormal color of video picture

Remote reception is insensitive or fails.

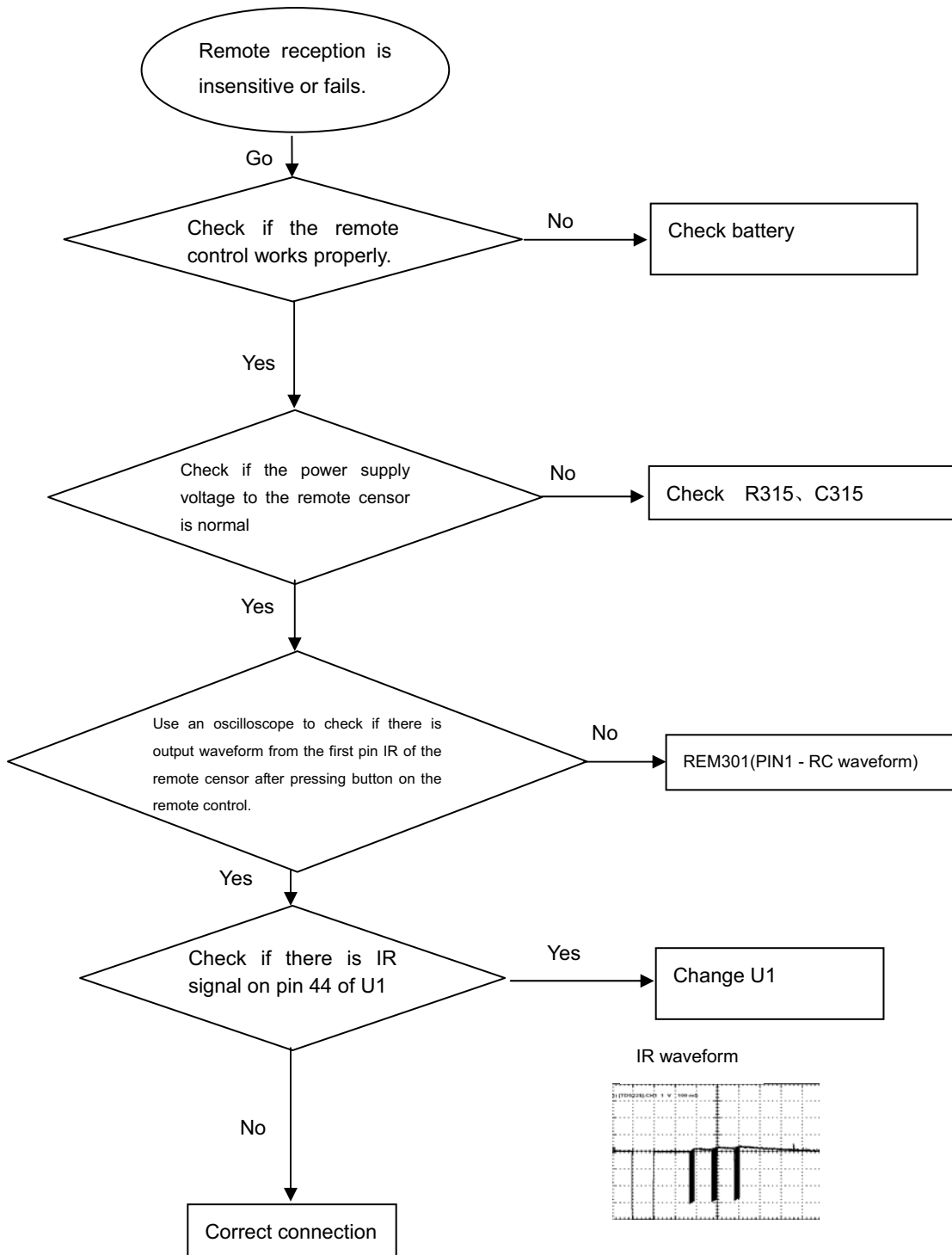

No video picture, no sound.

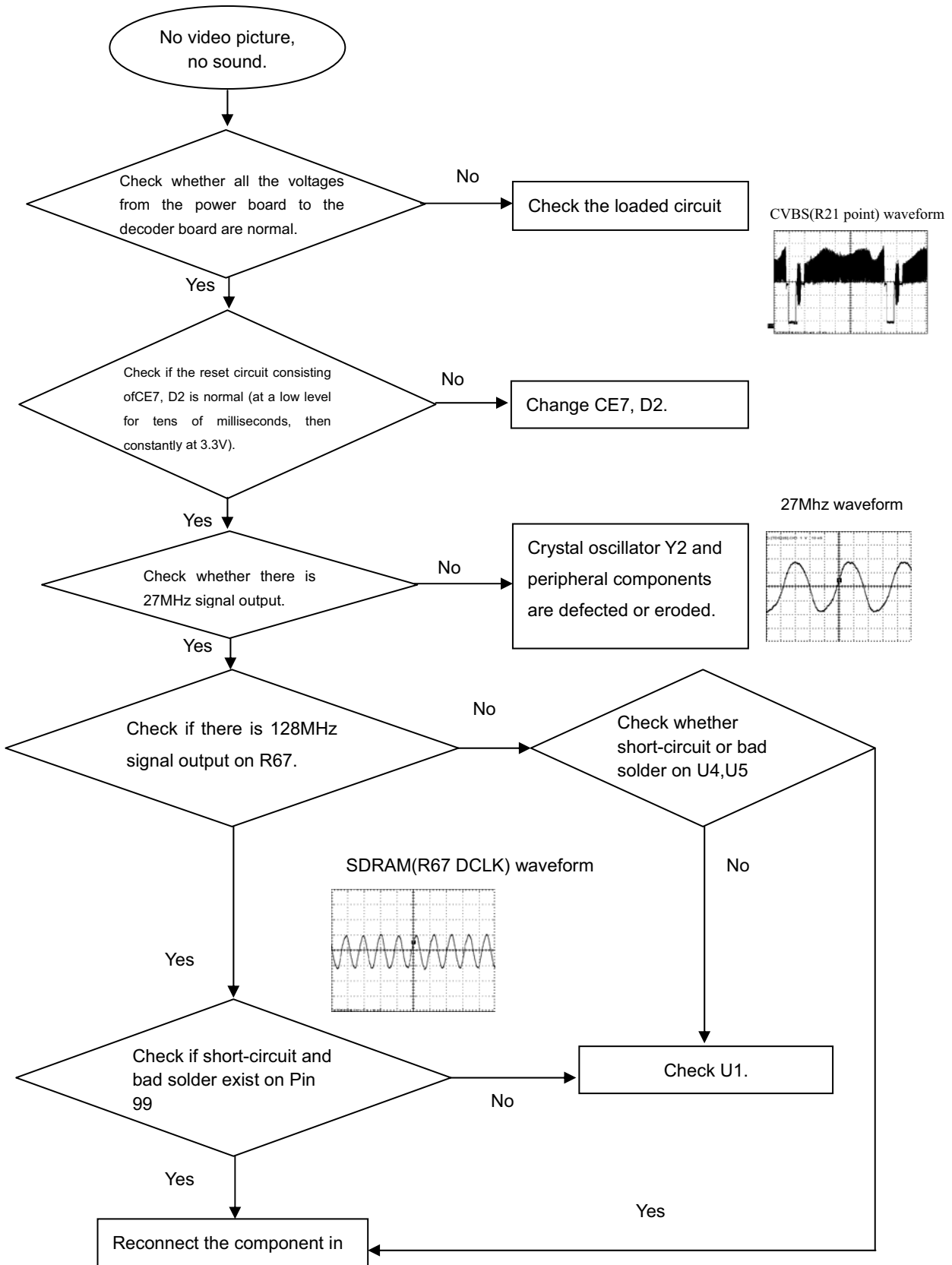

DVP/HTP3360K 2CH WIRING DIAGRAM

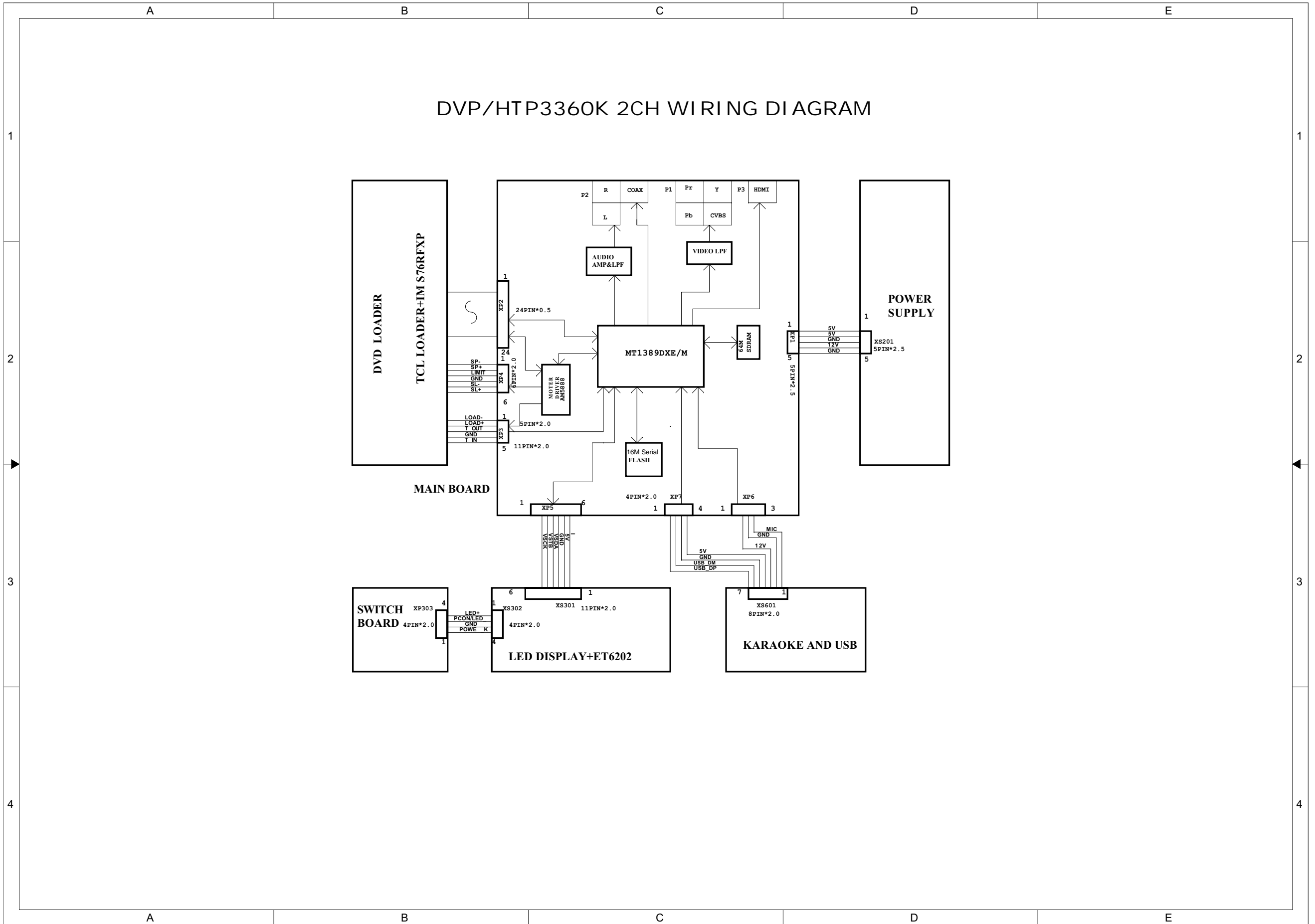

Switch Board Electric Diagram

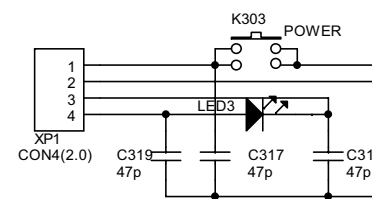

SWITCH BOARD

OK Board & USB Board Electric Diagram

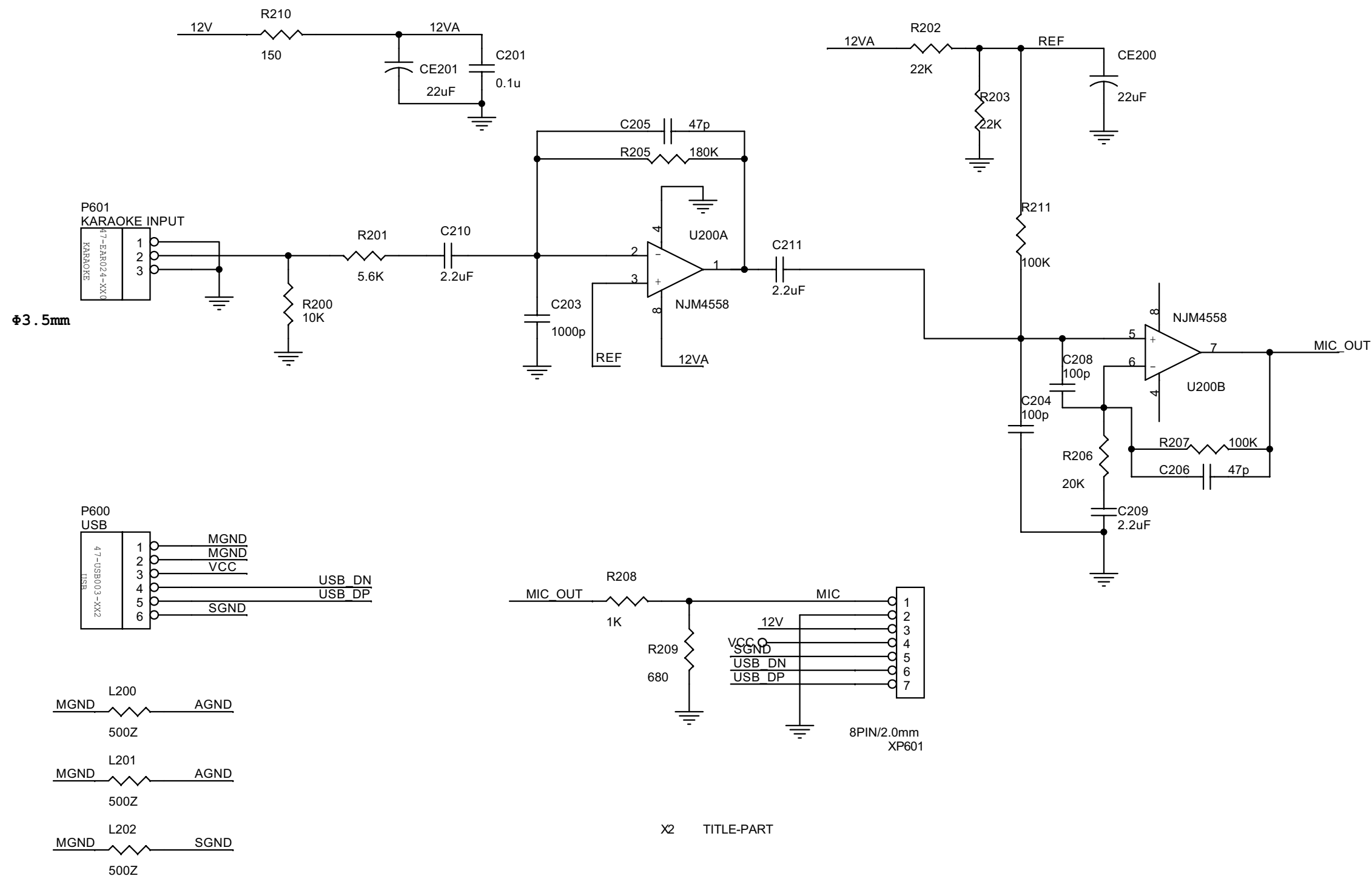

X2 TITLE-PART

Power Board Electric Diagram

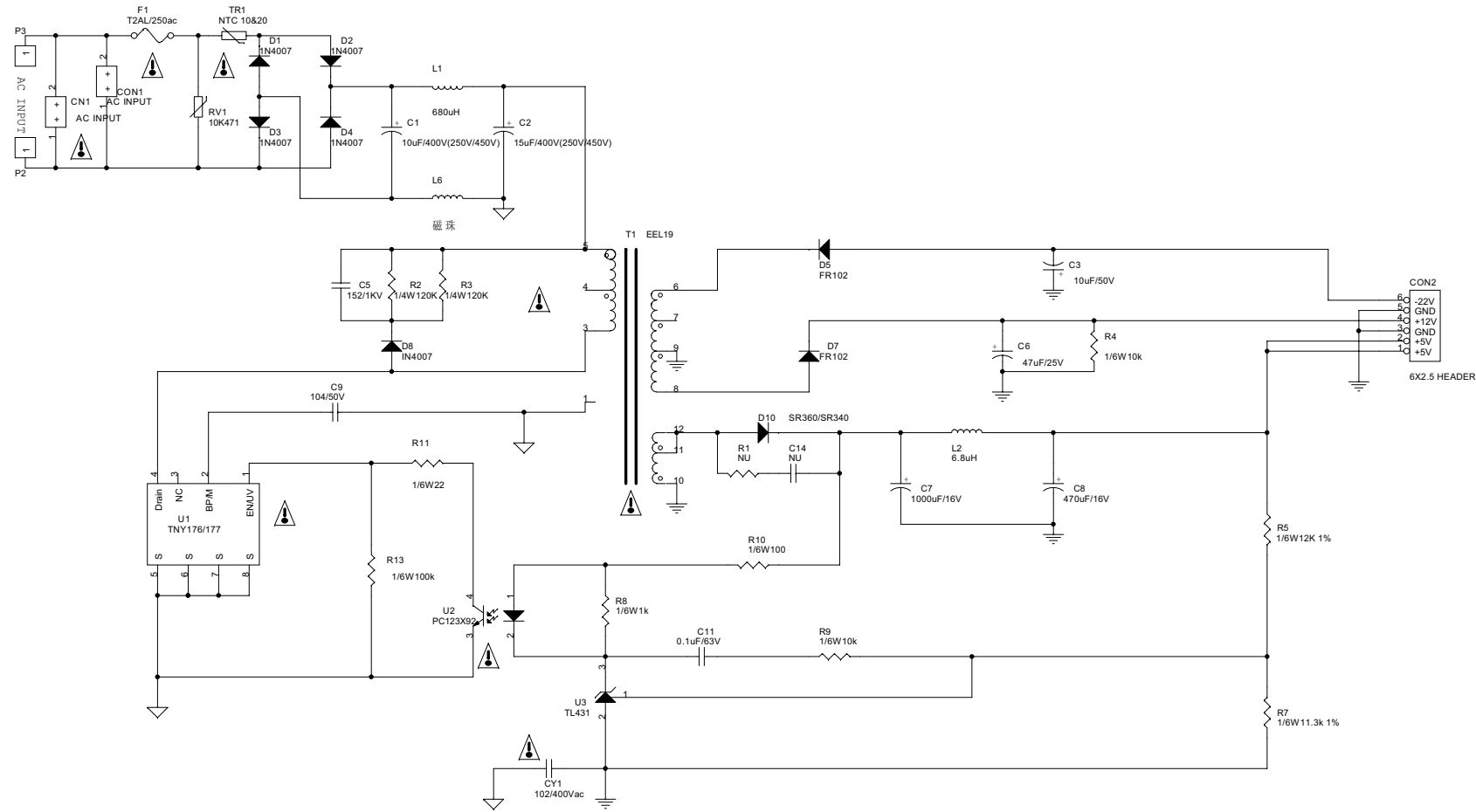

*** CAUTION :**
 THE PARTS MARKED WITH  ARE IMPORTANT PARTS ON THE SAFETY.
 PLEASE USE THE PARTS HAVING THE DESIGNATED PARTS NUMBER WITHOUT FAIL.

Main Board Electric Diagram: POWER Supply

TO POWER BOARD

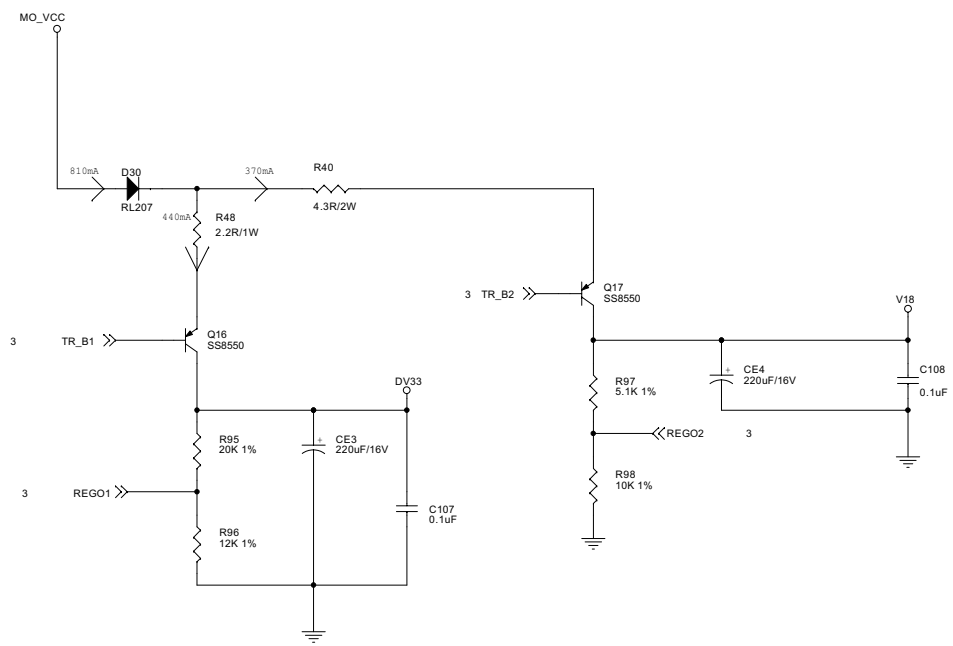
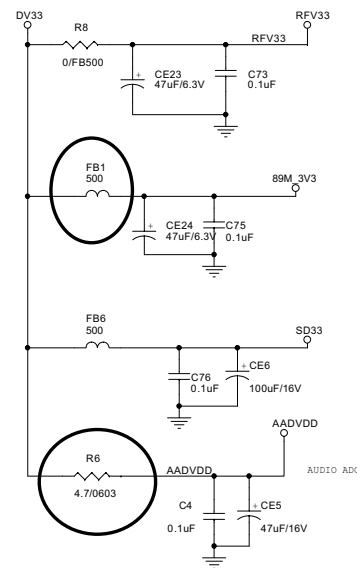
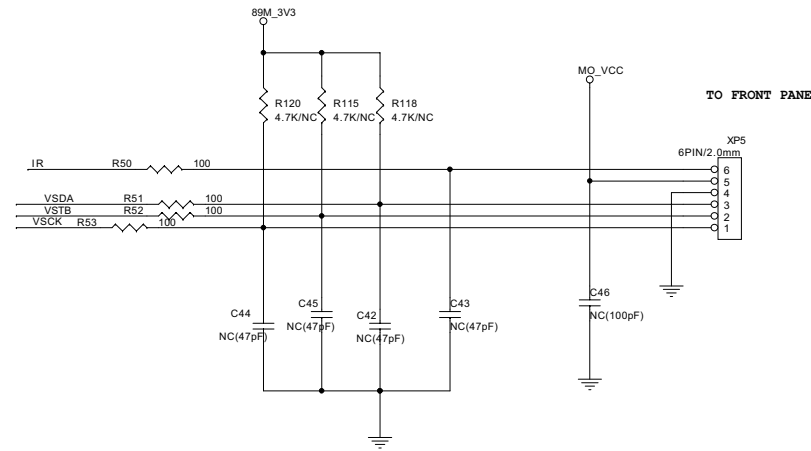
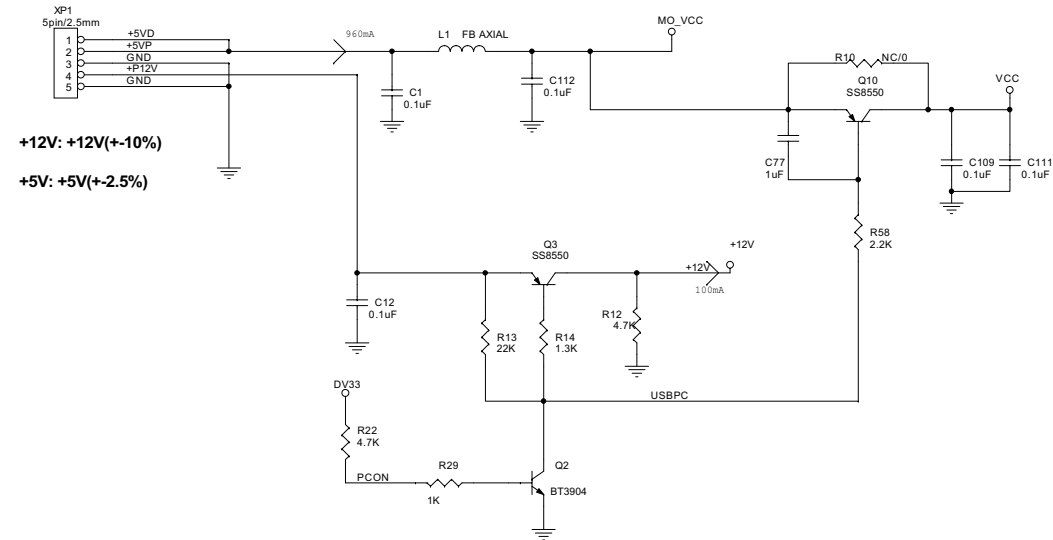

OFF-PAGE CONNECTION

URST#	URST#	(3,4)
MO_VCC	MO_VCC	(2,3,6)
SD33	SD33	4
VCC	VCC	(2,3,6,7)
DV33	DV33	(2,3,4,7)
RFV33	RFV33	3
89M_3V3	89M_3V3	3
V18	V18	(8)
VSK	VSK	3
VSDA	VSDA	3
VSTB	VSTB	3
IR	IR	3
PCON	PCON	3
AADVDD	AADVDD	3
USBPC	USBPC	3

ESET Circuit

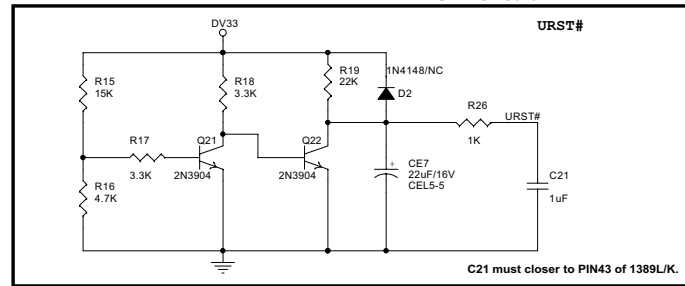

C21 must be closer to PIN43 of 1389L/K.

Main Board Electric Diagram: MT1389M

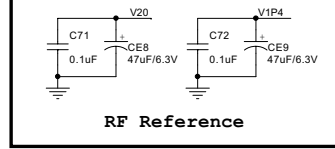
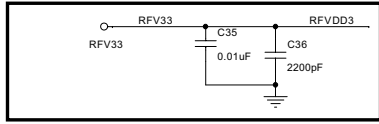
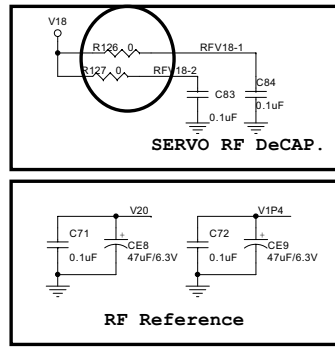
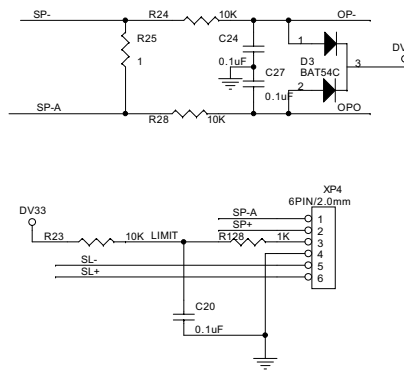

Main Board Electric Diagram: SDRAM & FLASH

SDR_DRAM (Dual Layout)

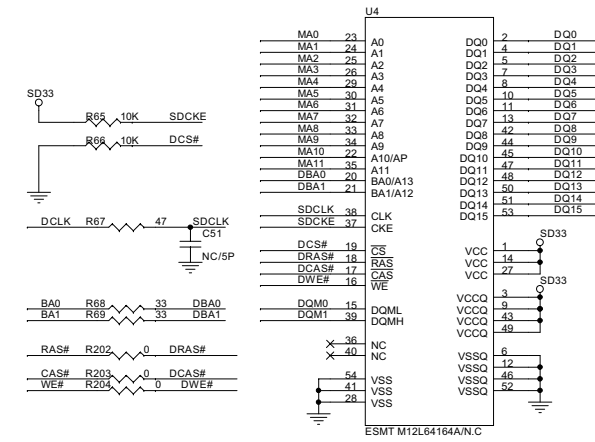

OFF-PAGE CONNECTION

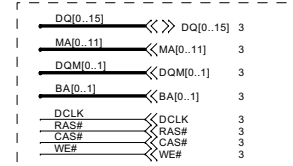

DRAM I/F

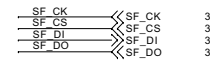

S-FLASH

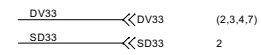

Power

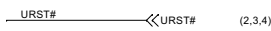

SerialFlash

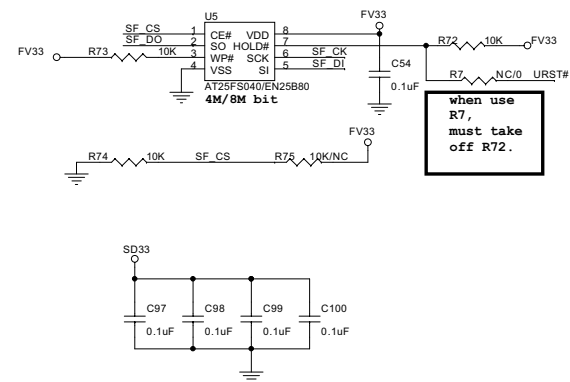

when use R7, must take off R72.

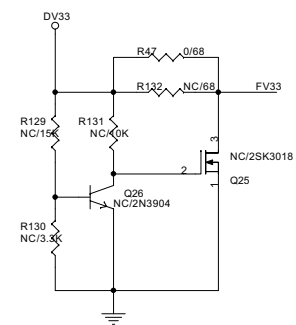

Main Board Electric Diagram: VIDEO OUT & AV-CONNECTOR

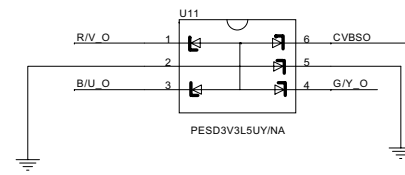
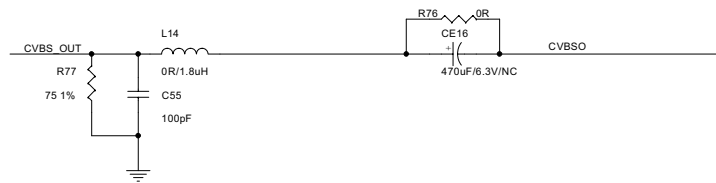
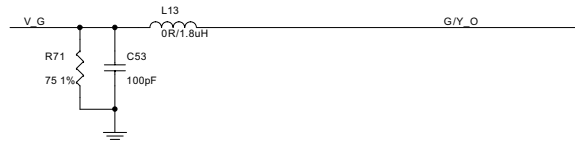
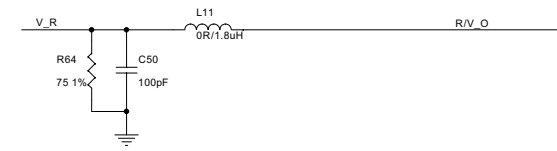

OFF-PAGE CONNECTION

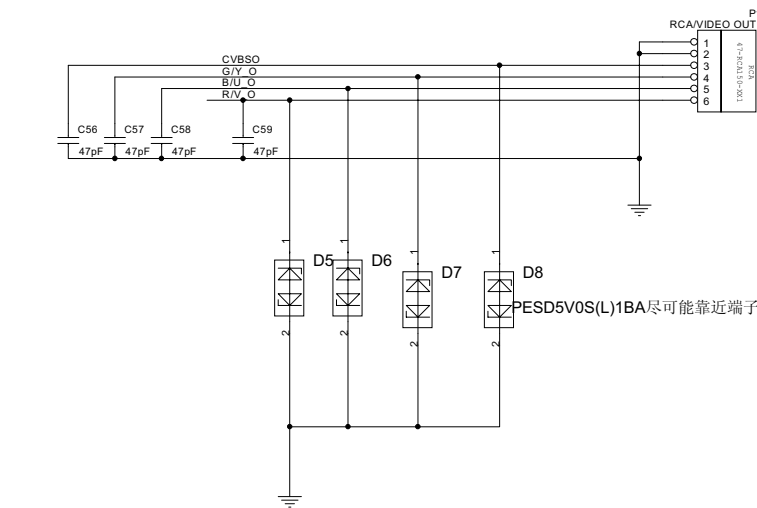
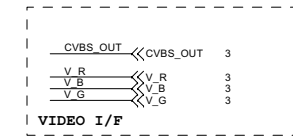

1

2

3

4

1

2

3

4

Main Board Electric Diagram: AUDIO OUTPUT

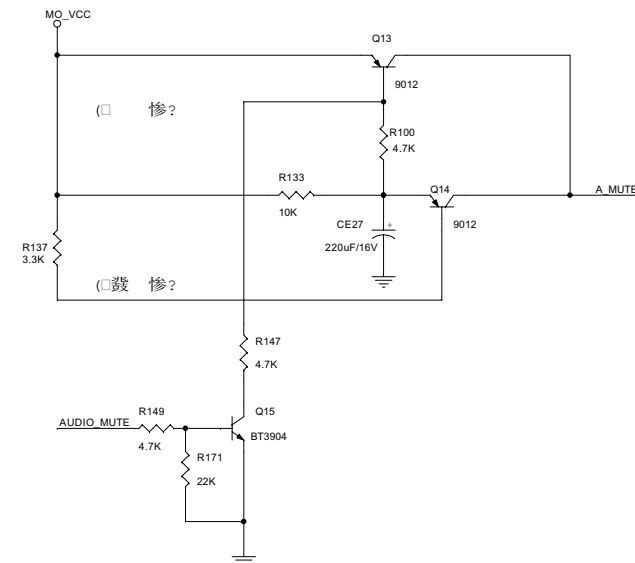
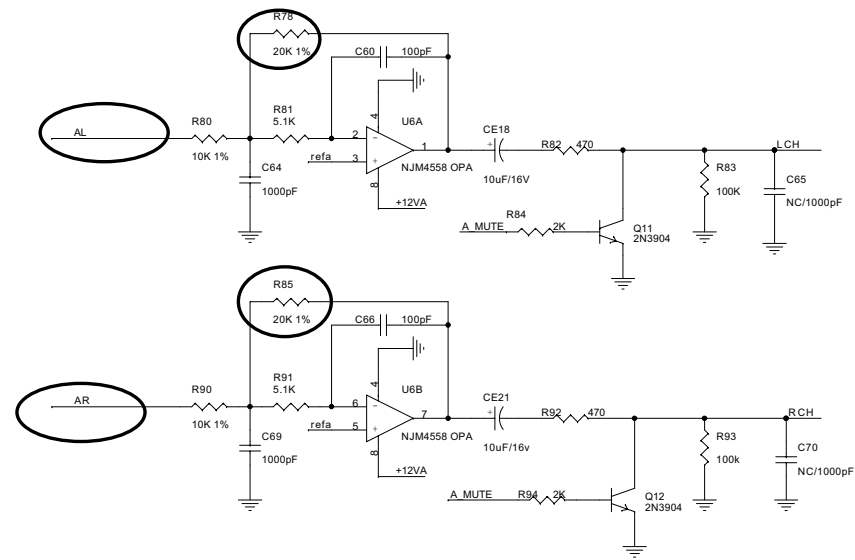

OFF-PAGE CONNECTION

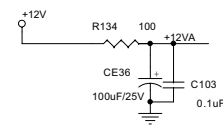
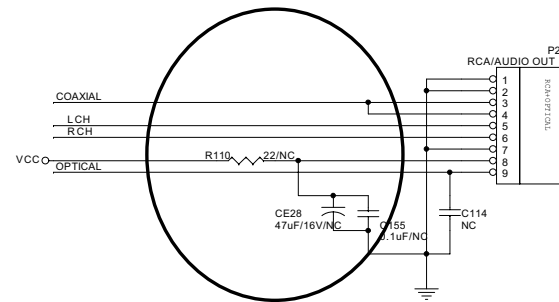
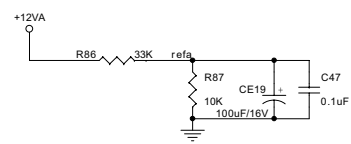
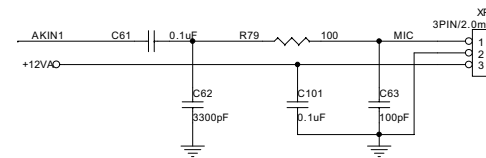
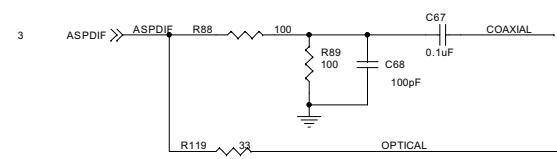
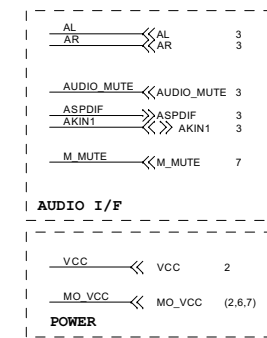

Main Board Electric Diagram: HDMI I/F

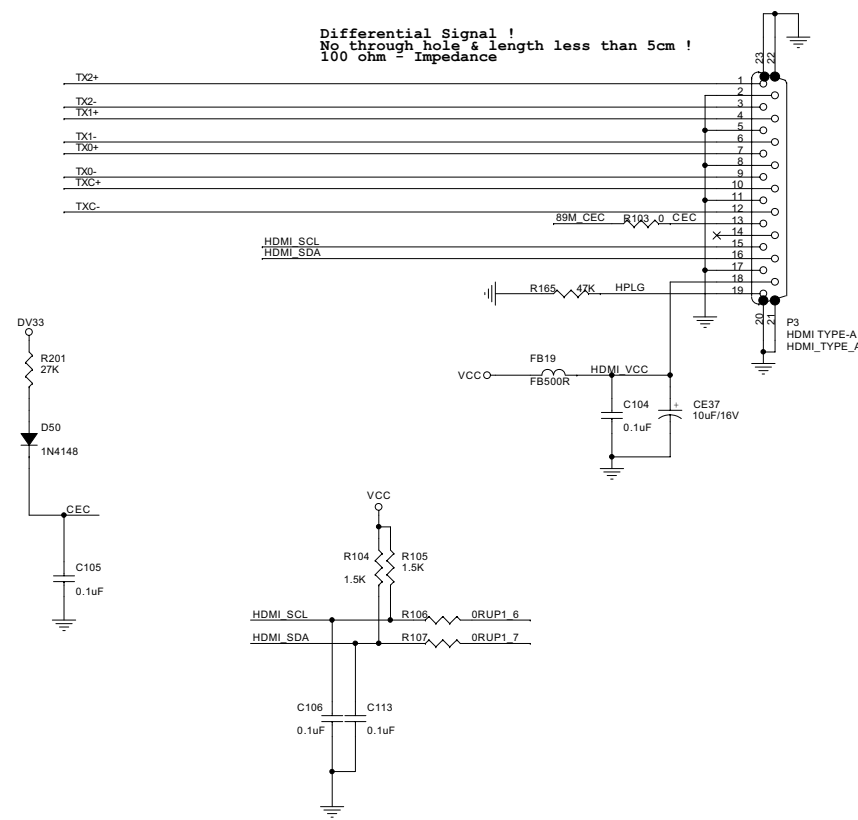

OFF-PAGE CONNECTION

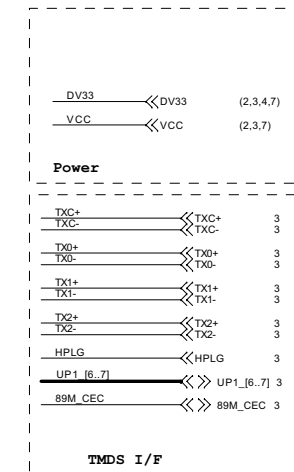

Main Board Print-layout (Bottom side):

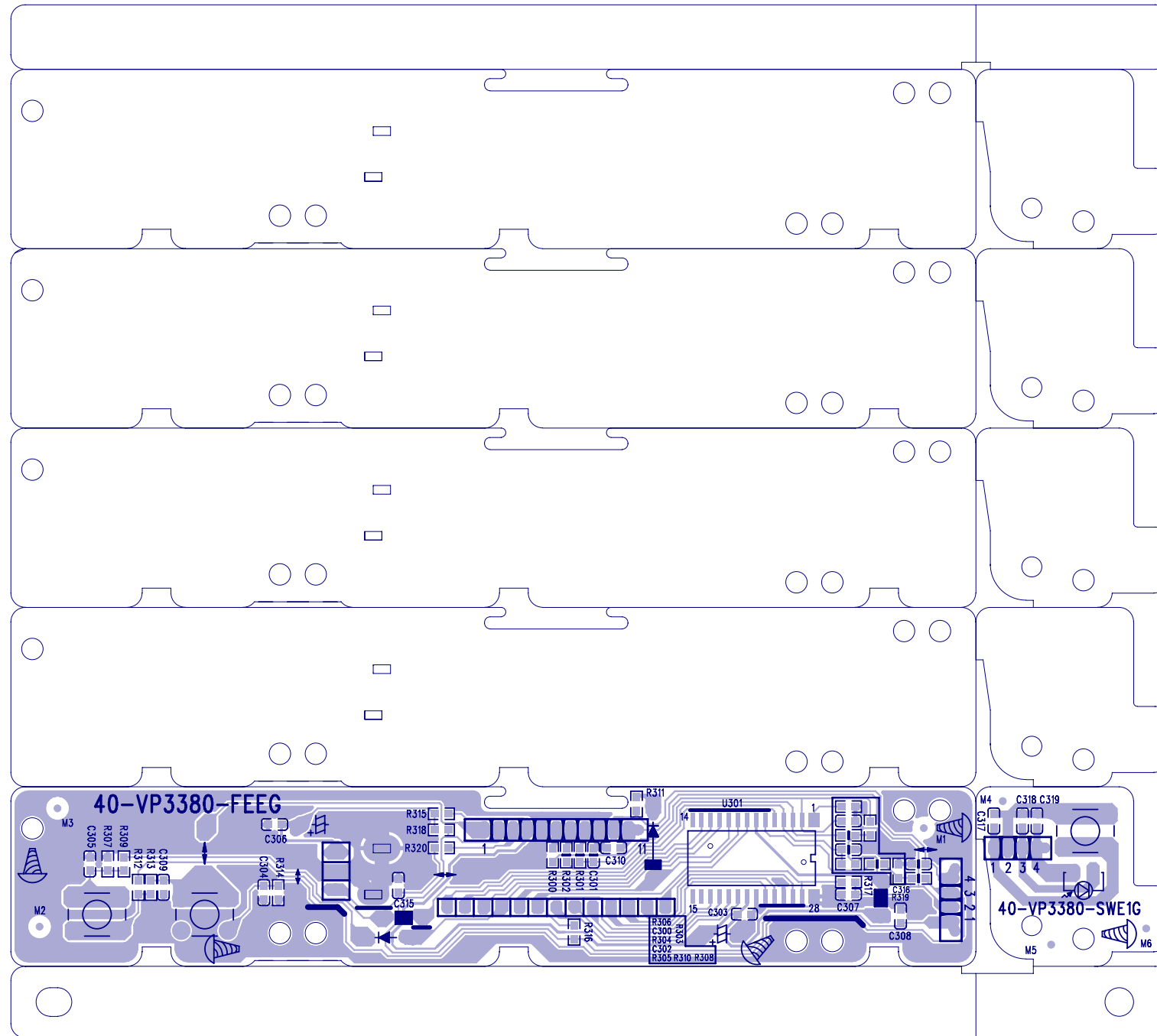

OK Board Print-layout (Top side):

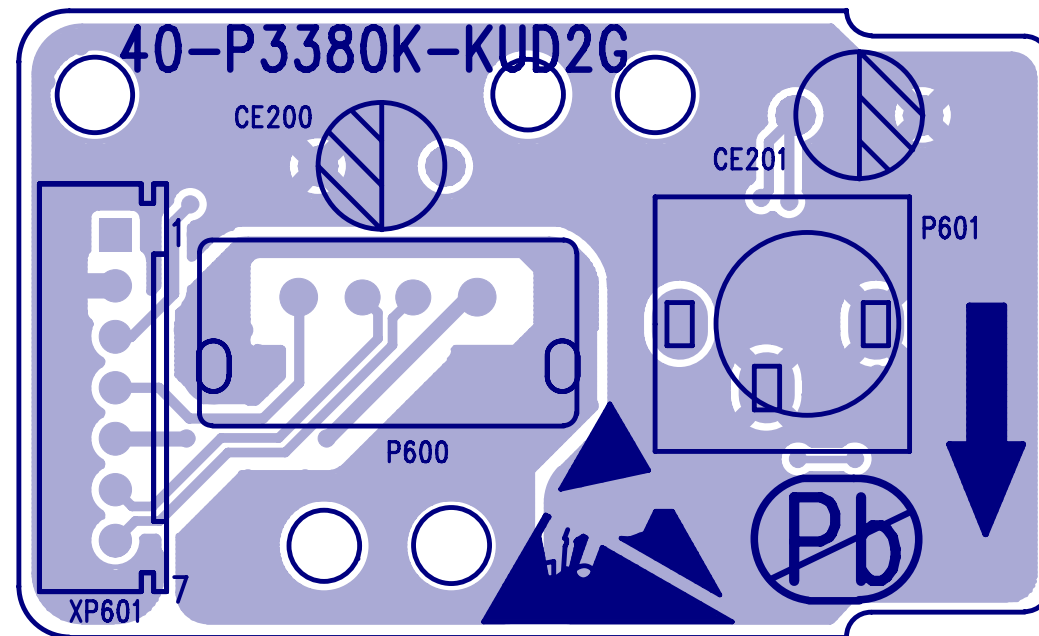

OK Board Print-layout (Bottom side):

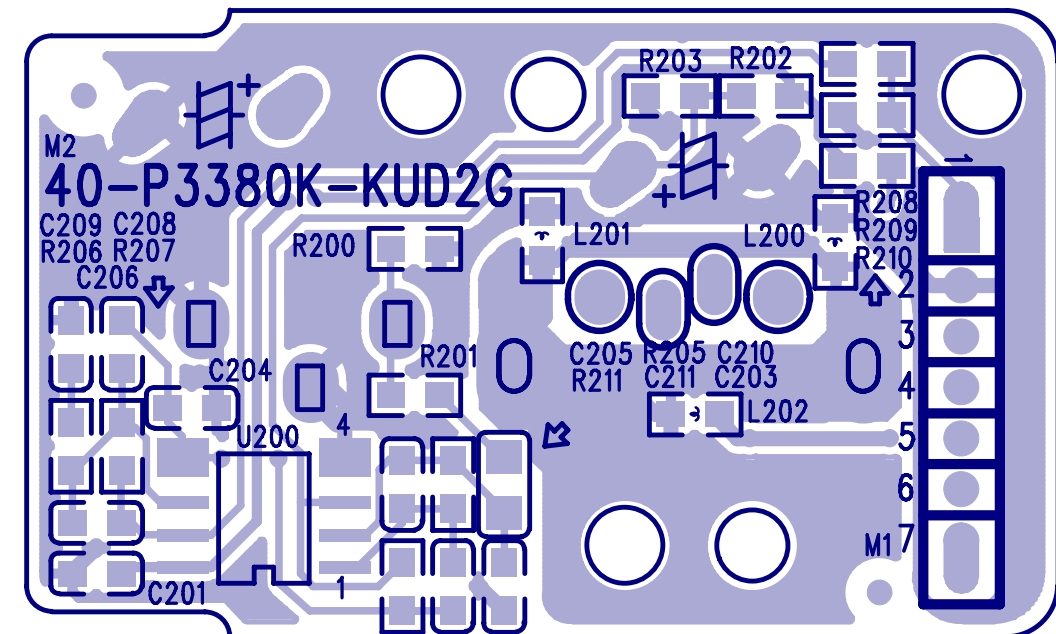

Power Board Print-layout(Bottom side):

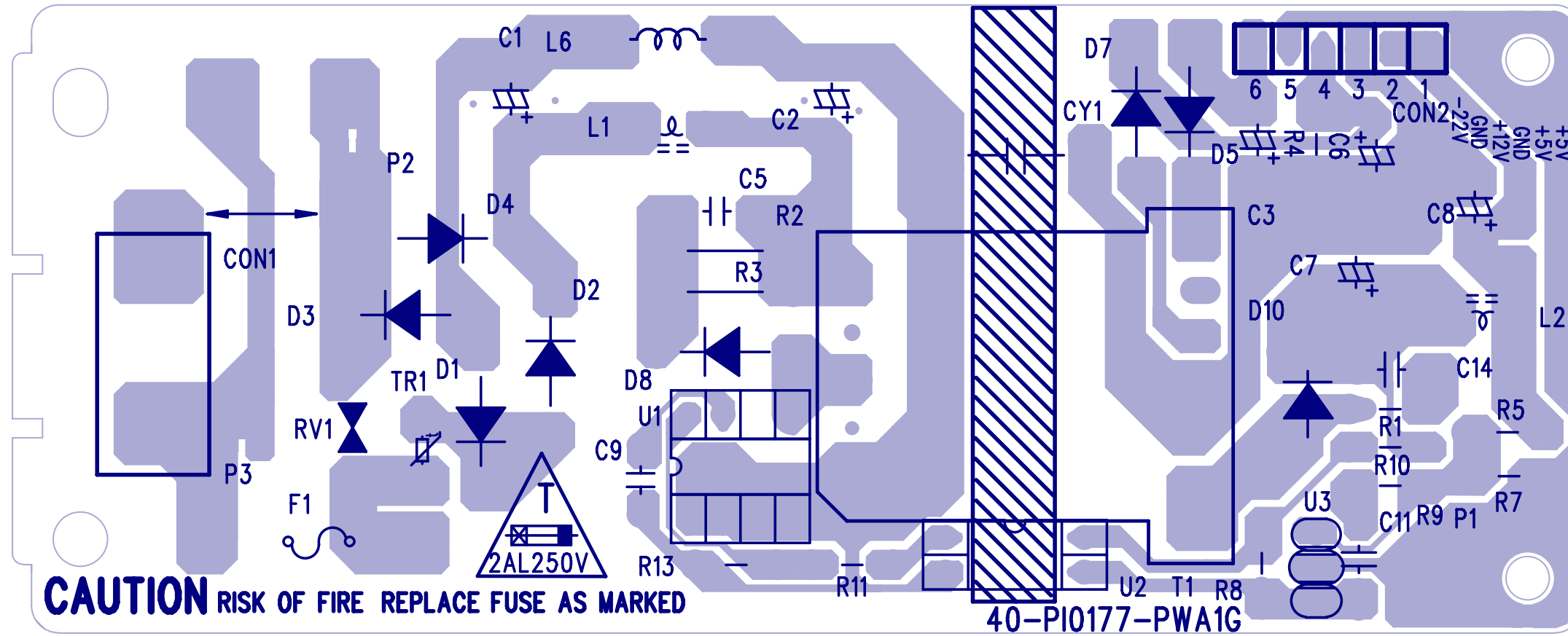

Main Board Print-layout (Top side):

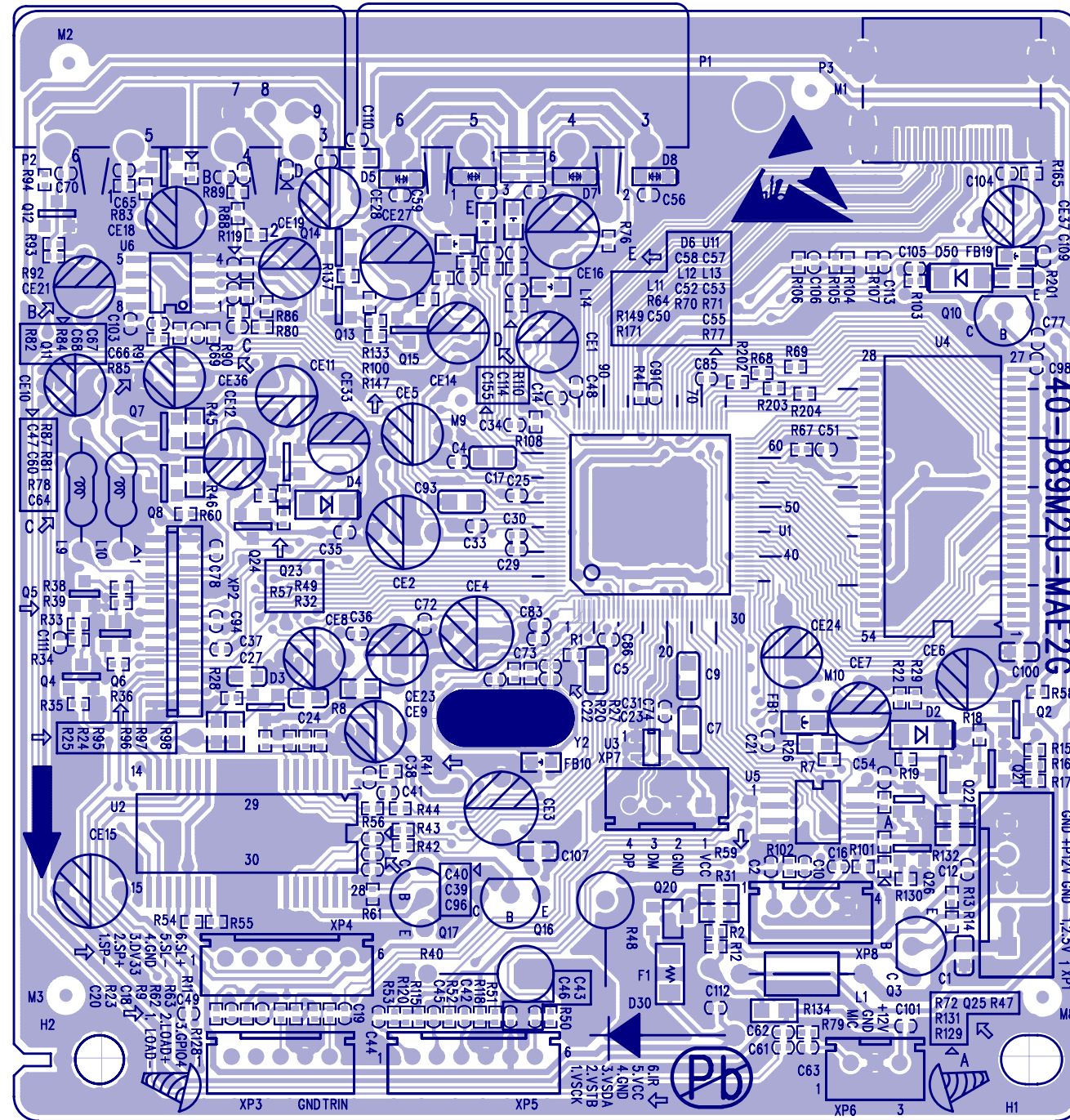

Main Board Print-layout (Bottom side):

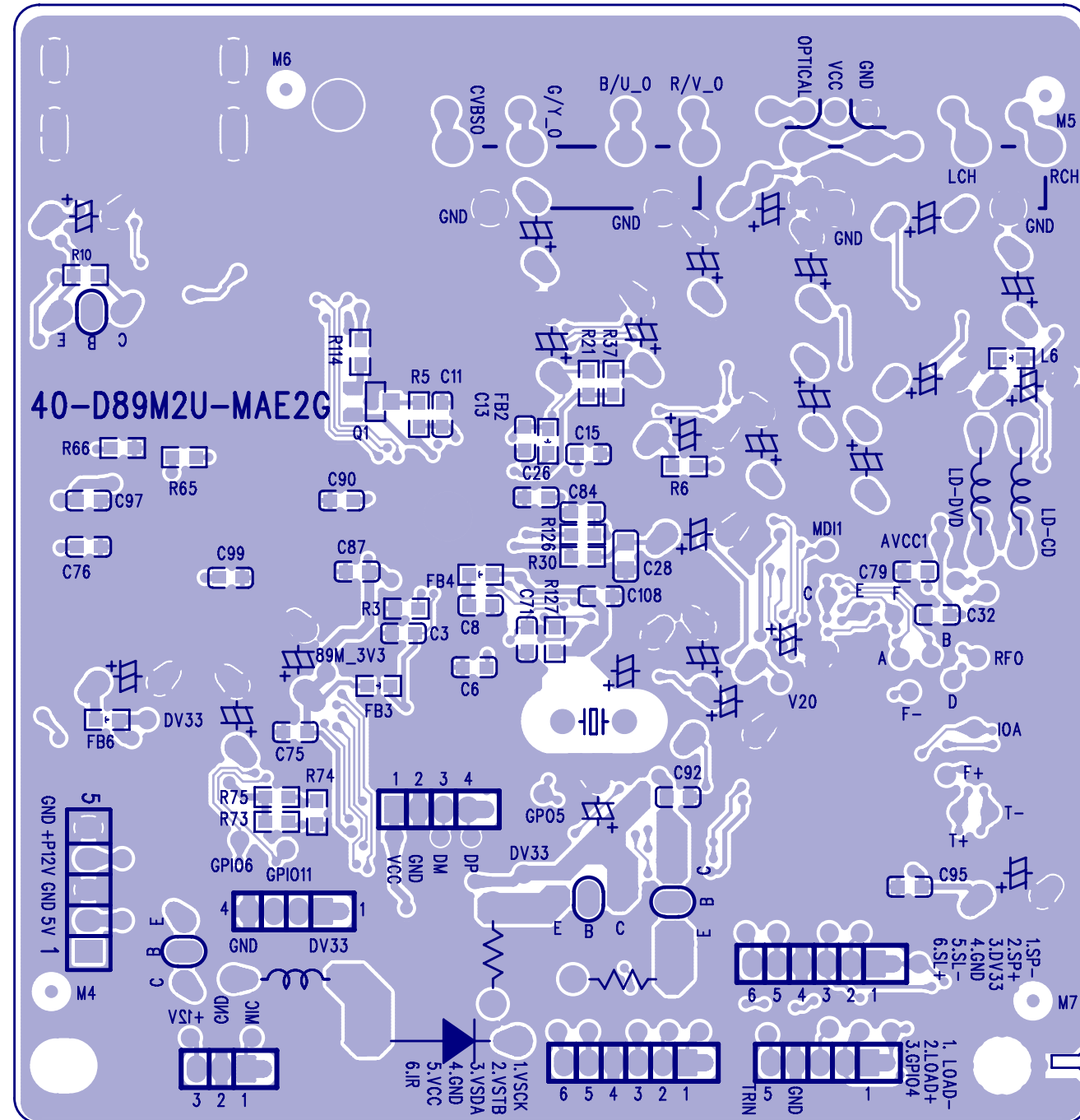

Exploded View for DVP3360K/55 & DVP/HTP3360K/98:

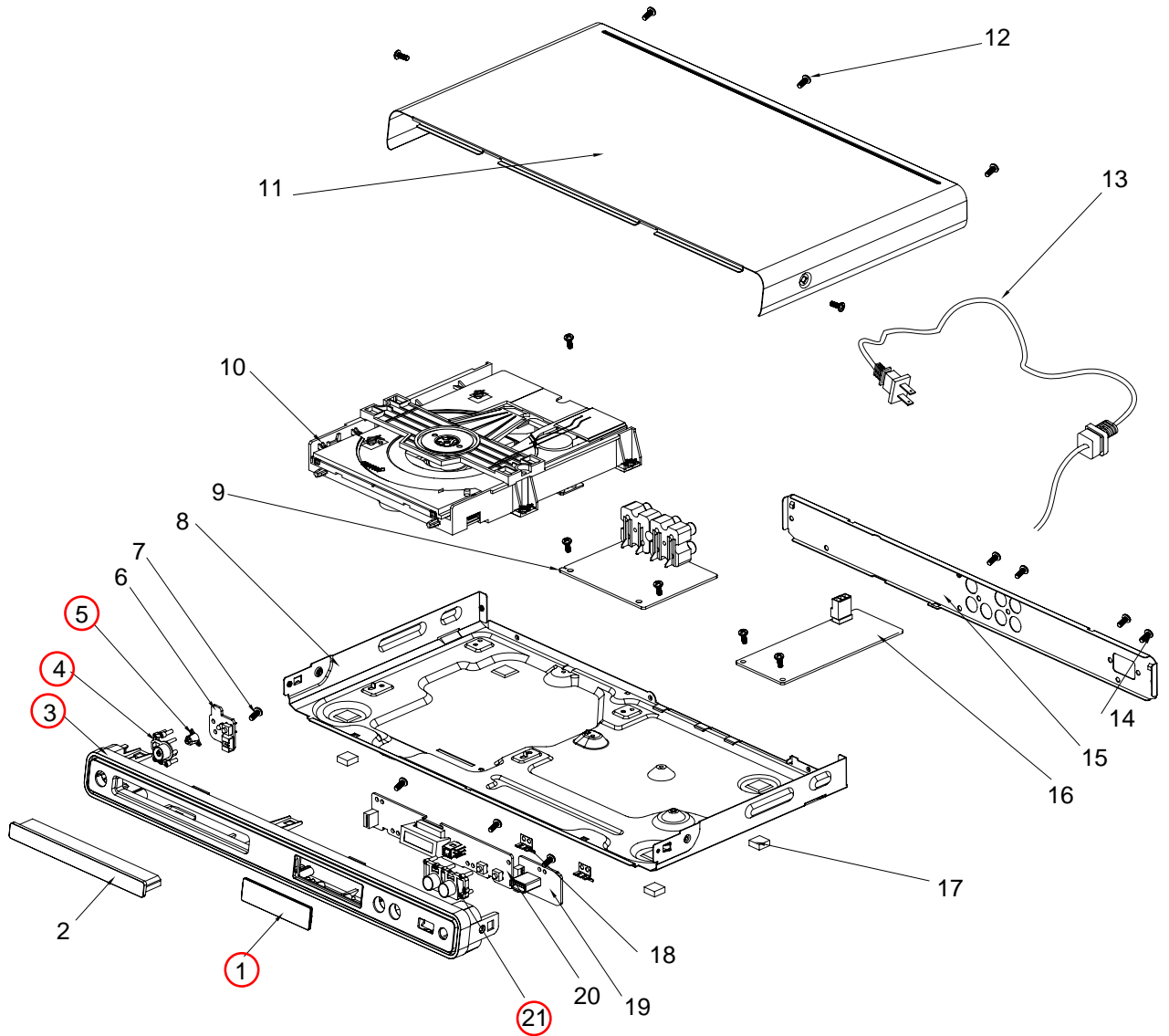

It's a general mechanical exploded view for DVP3360K/55 & DVP/HTP3360K/98.

Pls refer to the model set for detailed information.

Ass'y 1 includes components:1.3.4.5.21

Exploded view for DVP3360K/75

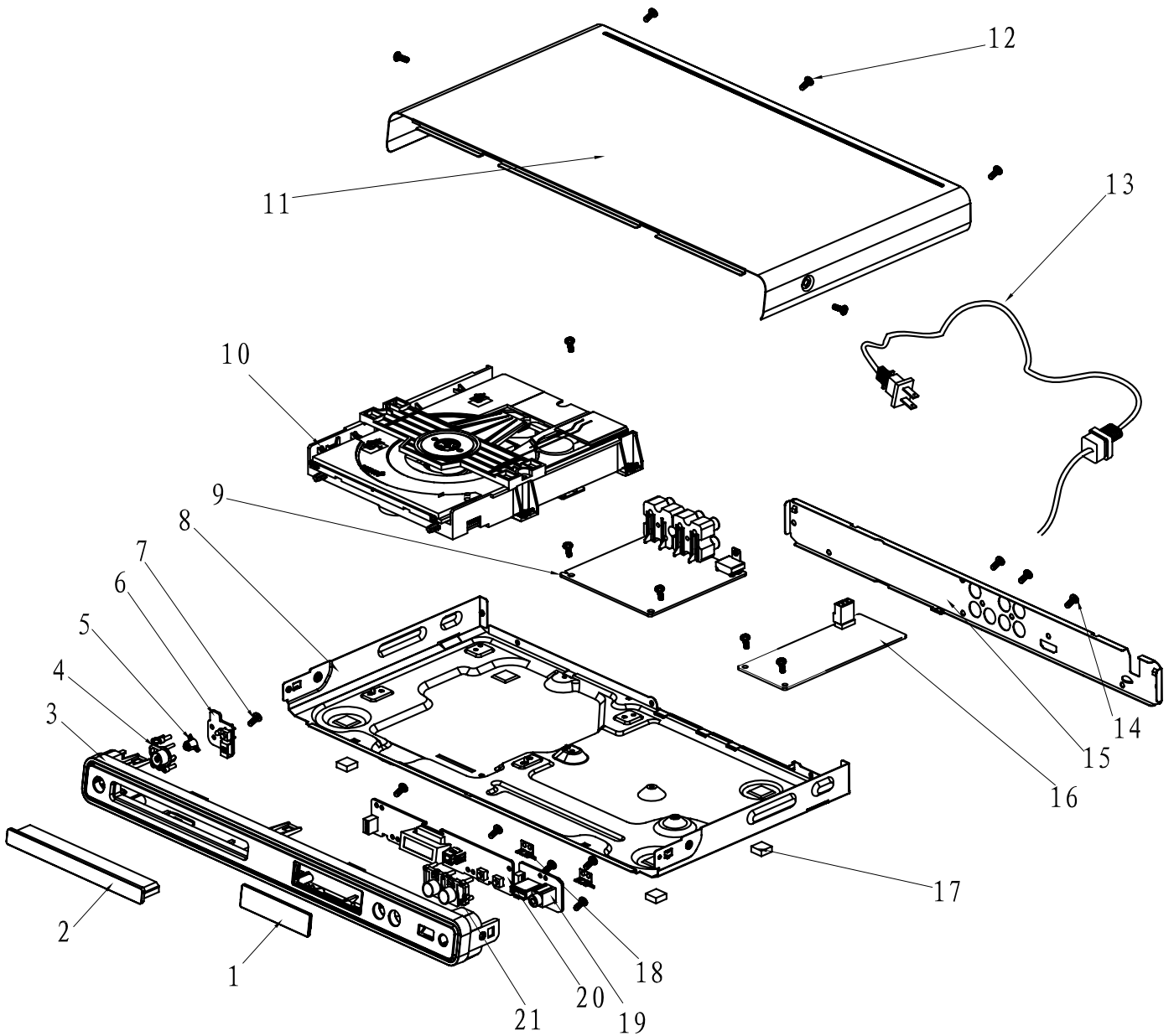

It's a general mechanical exploded view for DVP3360K/75, pls refer to the model set for detailed information.
Assy 1 components includes:1.3.4.5.21

DVP3360K/55 SERVICE PARTLIST

ELECTRICAL PARTLIST

No	12NC No.	Description	Q'ty
9	996510020963	ASSY-MAIN BD	1
20	996510020957	ASSY-FB BD	1
6	996510020934	ASSY-SW BD	1
△ 16	996510020953	ASSY-PW BD	1
19	996510020951	ASSY-KU BD	1
10	996510020955	DVD LOADER	1
OPU	996510020914	IM S76RFXP OPU	1

ASSY-MAIN BD COMPONENT PARTLIST

NO	12NC NO.	Description	Q'ty
D2	996510009667	SMD. SWITCHING DIODE LL4148	1
D3	996510009668	BAT54C	1
D4	996510009667	SMD. SWITCHING DIODE LL4148	1
D5	996510020926	IC PESD5V0S1BA	1
D50	996510009667	SMD. SWITCHING DIODE LL4148	1
D6	996510020926	IC PESD5V0S1BA	1
D7	996510020926	IC PESD5V0S1BA	1
D8	996510020926	IC PESD5V0S1BA	1
L10	996500014082	COIL CHOKE 10UH +/-10%	1
L9	996500014082	COIL CHOKE 10UH +/-10%	1
Q1	996510010922	ASM3402M/TR-LF SOT-23	1
Q10	996510009671	PNP TRANSISTOR	1
Q11	996510009669	SMD. TRANSISTOR MMBT3904LT1 NPN	1
Q12	996510009669	SMD. TRANSISTOR MMBT3904LT1 NPN	1
Q13	996510009670	TRANSISTOR SMT 3CG9012M	1
Q14	996510009670	TRANSISTOR SMT 3CG9012M	1
Q15	996510009669	SMD. TRANSISTOR MMBT3904LT1 NPN	1
Q16	996510009671	PNP TRANSISTOR	1
Q17	996510009671	PNP TRANSISTOR	1
Q2	996510009669	SMD. TRANSISTOR MMBT3904LT1 NPN	1
Q20	996510010949	MOSFET AO3402	1
Q21	996510009669	SMD. TRANSISTOR MMBT3904LT1 NPN	1
Q22	996510009669	SMD. TRANSISTOR MMBT3904LT1 NPN	1
Q23	996510009670	TRANSISTOR SMT 3CG9012M	1
Q24	996510009670	TRANSISTOR SMT 3CG9012M	1
Q3	996510009671	PNP TRANSISTOR	1
Q4	996510009669	SMD. TRANSISTOR MMBT3904LT1 NPN	1
Q5	996510009769	N Channel MOSFET 2SK3108	1
Q6	996510009769	N Channel MOSFET 2SK3108	1
Q7	996510009937	TRANSISTOR S8550LT1(PNP)	1
Q8	996510009937	TRANSISTOR S8550LT1(PNP)	1
U1	996510020958	MT1389DXE/M DECODE IC(NO KEY)	1
U2	996510009674	IC AM5888IC	1
U3	996510013349	HDMI USB ESD PYOTECTION IC	1
U4	996510020959	IC EM638165TS-6G	1
U5	996510020916	16M SPI FLASH EON	1
U6	996510010924	Dual operational amplifier	1
Y2	996510009675	27MCL20PF	1

ASSY-PW BD COMPONENT PARTLIST

NO	12NC NO.	Description	Q'ty
D1	996510011047	DIODE IN4007	1
D10	996500027866	DIODE SR360 3A/60V	1
D2	996510011047	DIODE IN4007	1
D3	996510011047	DIODE IN4007	1
D4	996510011047	DIODE IN4007	1
D7	996500014043	DIODE FR102 (FAST RECOVERY)	1
D8	996510011047	DIODE IN4007	1
L1	996510009942	COIL WIDTH	1
L2	996500032509	COIL SL0811-6R8K2R4	1
T1	996510010954	TRANSFORMER CONV	1
U1	996510012685	IC TNY177PN	1
U2	996500027867	PHOTOCOUPLER PS2561L1-1-V(WF)	1
U3	996500014609	IC AM431LP	1

ASSY-FB BD COMPONENT PARTLIST

NO	12NC NO.	Description	Q'ty
LED1	996510020917	J2808AG	1
REM301	996510020925	HM338-12 RECEIVER MOD H=12MM	1
U301	996510009665	IC ET6202 SOP-2	1

ASSY-KU BD COMPONENT PARTLIST

NO	12NC NO.	Description	Q'ty
U200	996500032494	IC AS4558M	1

MECHANICAL PARTLIST

No	12NC No.	Description	Q'ty
RC	996510020927	REMOTE CONTROL	1
11	996510020952	TOP COVER	1
15	996510020971	BACK PANEL	1
AVCABLE	996510001106	VIDEO CABLE 1500mm	1
ASSY1	996510020949	ASSY FRONT DOOR	1
HDMICABLE	996510018621	HDMI Cable	1
△ 13	996510001175	POWER CORD	1
△ POWERSOCKET	996510020885	POWER SOCKET transition	1
17	996510006463	PAD	4
△ 8	996510020964	BOTTOM PLATE	1
2	996510020948	FRONT DOOR	1
XP1	996510011060	5PIN CBL TJC3-5Y/SCN-5P L=70MM	1
XP2	996510020954	24PIN FFC CONN 0.5PITCH L:200	1
XP3	996510020961	5P CABLE PH-5Y/JC20-5P L=150MM	1
XP4	996510020921	6PIN CBL PH-6Y*2 20080#28	1
XP601	996510020962	7PIN CABLE WITH SHIELD(XP7:140/XP6:180)	1
XS301	996510010479	6PIN HS L=120MM	1

SCREWS LIST:

No	12NC No.	Description	Q'ty
7	—	S/T SCREW B 2.6 X 8 BF	6
12	—	S/T SCREW B3 X 6 BF	9
14	—	S/T SCREW B 3 X 7 BF	5

DVP3360K/98 SERVICE PARTLIST

ELECTRICAL PARTLIST

No	12NC No.	Description	Q'ty
9	996510022284	ASSY-MAIN BD	1
△ 16	996510020953	ASSY-PW BD	1
19	996510020951	ASSY-KU BD	1
20	996510020957	ASSY-FB BD	1
6	996510020934	ASSY-SW BD	1
10	996510020955	DVD LOADER	1
OPU	996510020914	IM S76RFXP OPU	1

ASSY-MAIN BD COMPONENT PARTLIST

NO	12NC NO.	Description	Q'ty
D2	996510009667	SMD. SWITCHING DIODE LL4148	1
D3	996510009668	BAT54C	1
D4	996510009667	SMD. SWITCHING DIODE LL4148	1
D50	996510009667	SMD. SWITCHING DIODE LL4148	1
L10	996500014082	COIL CHOKE 10UH +/-10%	1
L9	996500014082	COIL CHOKE 10UH +/-10%	1
Q1	996510010922	ASM3402M/TR-LF SOT-23	1
Q10	996510009671	PNP TRANSISTOR	1
Q11	996510009669	SMD.TRANSISTOR MMBT3904LT1 NPN	1
Q12	996510009669	SMD.TRANSISTOR MMBT3904LT1 NPN	1
Q13	996510009670	TRANSISTOR SMT 3CG9012M	1
Q14	996510009670	TRANSISTOR SMT 3CG9012M	1
Q15	996510009669	SMD.TRANSISTOR MMBT3904LT1 NPN	1
Q16	996510009671	PNP TRANSISTOR	1
Q17	996510009671	PNP TRANSISTOR	1
Q2	996510009669	SMD.TRANSISTOR MMBT3904LT1 NPN	1
Q20	996510010949	MOSFET AO3402	1
Q21	996510009669	SMD.TRANSISTOR MMBT3904LT1 NPN	1
Q22	996510009669	SMD.TRANSISTOR MMBT3904LT1 NPN	1
Q23	996510009670	TRANSISTOR SMT 3CG9012M	1
Q24	996510009670	TRANSISTOR SMT 3CG9012M	1
Q3	996510009671	PNP TRANSISTOR	1
Q4	996510009669	SMD.TRANSISTOR MMBT3904LT1 NPN	1
Q5	996510009769	N Channel MOSFET 2SK3108	1
Q6	996510009769	N Channel MOSFET 2SK3108	1
Q7	996510009937	TRANSISTOR S8550LT1(PNP)	1
Q8	996510009937	TRANSISTOR S8550LT1(PNP)	1
U1	996510020958	MT1389DXE/M DECODE IC(NO KEY)	1
U11	996510021013	IC PESD5VL4UG	1
U2	996510011055	IC CD5888CB	1
U3	996510013349	HDMI USB ESD PYOTECTION IC	1
U4	996510013315	64M SDRAM HY57V641620FTP-7-C	1
U5	996510021491	16M SPI flash ESMT	1
U6	996510010924	Dual operational amplifier	1
Y2	996510009675	27MCL20PF	1

ASSY-PW BD COMPONENT PARTLIST

NO	12NC NO.	Description	Q'ty
D1	996510011047	DIODE IN4007	1
D10	996500027866	DIODE SR360 3A/60V	1
D2	996510011047	DIODE IN4007	1
D3	996510011047	DIODE IN4007	1
D4	996510011047	DIODE IN4007	1
D7	996500014043	DIODE FR102 (FAST RECOVERY)	1
D8	996510011047	DIODE IN4007	1
L1	996510009942	COIL WIDTH	1
L2	996500032509	COIL SL0811-6R8K2R4	1
T1	996510010954	TRANSFORMER CONV	1
U1	996510012685	IC TNY177PN	1
U2	996500027867	PHOTOCOUPLER PS2561L1-1-V(WF)	1
U3	996500014609	IC AM431LP	1

ASSY-FB BD COMPONENT PARTLIST

NO	12NC NO.	Description	Q'ty
LED1	996510020917	J2808AG	1
REM301	996510020925	HM338-12 RECEIVER MOD H=12MM	1
U301	996510009665	IC ET6202 SOP-2	1

ASSY-KU BD COMPONENT PARTLIST

NO	12NC NO.	Description	Q'ty
U200	996500032494	IC AS4558M	1

MECHANICAL PARTLIST

No	12NC No.	Description	Q'ty
11	996510020952	TOP COVER	1
△ 13	996510001537	POWER CORD	1
15	996510022347	BACK PANEL	1
17	996510006463	PAD	4
2	996510020948	FRONT DOOR	1
△ 8	996510020964	BOTTOM PLATE	1
AVCABLE	996510001106	VIDEO CABLE 1500mm	1
Assy1	996510020949	ASSY FRONT DOOR	1
CON2	996510011060	5PINCBLE TJC3-5Y/SCN-5P L=70MM	1
RC	996510020927	REMOTE CONTROL	1
XP2	996510020954	24PIN FFC CONN 0.5PITCH L:200	1
XP3	996510020961	5P CABLE PH-5Y/JC20-5P L=150MM	1
XP4	996510020921	6PIN CBL PH-6Y*2 20080#28	1
XP601	996510020962	7PIN CABLE WITH SHIELD(XP7:	1
XS301	996510010479	6PIN HS L=120MM	1

SCREWS LIST:

No	12NC No.	Description	Q'ty
7	—	S/T SCREW B 2.6 X 8 BF	6
12	—	S/T SCREW B3 X 6 BF	9
14	—	S/T SCREW B 3 X 7 BF	5

DVP3360K/75 SERVICE PARTLIST

ELECTRICAL PARTLIST

No	12NC No.	Description	Q'ty
9	996510023053	ASSY-MAIN BD	1
△ 16	996510023052	ASSY-PW BD	1
19	996510020951	ASSY-KU BD	1
20	996510020957	ASSY-FB BD	1
6	996510020934	ASSY-SW BD	1
10	996510020955	DVD LOADER	1
OPU	996510020914	IM S76RFXP OPU	1

ASSY-MAIN BD COMPONENT PARTLIST

NO	12NC NO.	Description	Q'ty
D2	996510009667	SMD. SWITCHING DIODE LL4148	1
D3	996510009668	BAT54C	1
D4	996510009667	SMD. SWITCHING DIODE LL4148	1
D50	996510009667	SMD. SWITCHING DIODE LL4148	1
L10	996500014082	COIL CHOKE 10UH +/-10%	1
L9	996500014082	COIL CHOKE 10UH +/-10%	1
Q1	996510010922	ASM3402M/TR-LF SOT-23	1
Q10	996510009671	PNP TRANSISTOR	1
Q11	996510009669	SMD.TRANSISTOR MMBT3904LT1 NPN	1
Q12	996510009669	SMD.TRANSISTOR MMBT3904LT1 NPN	1
Q13	996510009670	TRANSISTOR SMT 3CG9012M	1
Q14	996510009670	TRANSISTOR SMT 3CG9012M	1
Q15	996510009669	SMD.TRANSISTOR MMBT3904LT1 NPN	1
Q16	996510009671	PNP TRANSISTOR	1
Q17	996510009671	PNP TRANSISTOR	1
Q2	996510009669	SMD.TRANSISTOR MMBT3904LT1 NPN	1
Q20	996510010949	MOSFET AO3402	1
Q21	996510009669	SMD.TRANSISTOR MMBT3904LT1 NPN	1
Q22	996510009669	SMD.TRANSISTOR MMBT3904LT1 NPN	1
Q23	996510009670	TRANSISTOR SMT 3CG9012M	1
Q24	996510009670	TRANSISTOR SMT 3CG9012M	1
Q3	996510009671	PNP TRANSISTOR	1
Q4	996510009669	SMD.TRANSISTOR MMBT3904LT1 NPN	1
Q5	996510009769	N Channel MOSFET 2SK3108	1
Q6	996510009769	N Channel MOSFET 2SK3108	1
Q7	996510009937	TRANSISTOR S8550LT1(PNP)	1
Q8	996510009937	TRANSISTOR S8550LT1(PNP)	1
U1	996510020958	MT1389DXE/M DECODE IC(NO KEY)	1
U11	996510021013	IC PESD5VL4UG	1
U2	996510011055	IC CD5888CB	1
U3	996510013349	HDMI USB ESD PYOTECTION IC	1
U4	996510013315	64M SDRAM HY57V641620FTP-7-C	1
U5	996510021491	16M SPI flash ESMT	1
U6	996510010924	Dual operational amplifier	1
Y2	996510009675	27MCL20PF	1

ASSY-PW BD COMPONENT PARTLIST

NO	12NC NO.	Description	Q'ty
D1	996510011047	DIODE IN4007	1
D10	996500027866	DIODE SR360 3A/60V	1
D2	996510011047	DIODE IN4007	1
D3	996510011047	DIODE IN4007	1
D4	996510011047	DIODE IN4007	1
D7	996500014043	DIODE FR102 (FAST RECOVERY)	1
D8	996510011047	DIODE IN4007	1
L1	996510009942	COIL WIDTH	1
L2	996500032509	COIL SL0811-6R8K2R4	1
T1	996510010954	TRANSFORMER CONV	1
U1	996510012685	IC TNY177PN	1
U2	996500027867	PHOTOCOUPLER PS2561L1-1-V(WF)	1
U3	996500014609	IC AM431LP	1

ASSY-KU BD COMPONENT PARTLIST

NO	12NC NO.	Description	Q'ty
U200	996500032494	IC AS4558M	1

ASSY-FB BD COMPONENT PARTLIST

NO	12NC NO.	Description	Q'ty
LED1	996510020917	J2808AG	1
REM301	996510020925	HM338-12 RECEIVER MOD H=12MM	1
U301	996510009665	IC ET6202 SOP-2	1

MECHANICAL PARTLIST

No	12NC No.	Description	Q'ty
11	996510020952	TOP COVER	1
△ 13	996510002166	POWER CORD	1
15	996510023057	BACK PANEL	1
17	996510006463	PAD	4
△ 8	996510020964	BOTTOM PLATE	1
AVCABLE	996510001106	VIDEO CABLE 1500mm	1
Assy1	996510020949	ASSY FRONT DOOR	1
CON2	996510011060	5PINBLE TJC3-5Y/SCN-5P L=70MM	1
RC	996510020927	REMOTE CONTROL	1
XP2	996510020954	24PIN FFC CONN 0.5PITCH L:200	1
XP3	996510020961	5P CABLE PH-5Y/JC20-5P L=150MM	1
XP5	996510020921	6PIN CBL PH-6Y*2 20080#28	1
XP601	996510020962	7PIN CABLE WITH SHIELD(XP7:	1
XS301	996510010479	6PIN HS L=120MM	1
2	996510020948	FRONT DOOR	1

SCREWS LIST:

No	12NC No.	Description	Q'ty
7	—	S/T SCREW B 2.6 X 8 BF	6
12	—	S/T SCREW B3 X 6 BF	9
14	—	S/T SCREW B 3 X 7 BF	5

HTP3360K/98 SERVICE PARTLIST

ELECTRICAL PARTLIST

No	12NC No.	Description	Q'ty
9	996510022284	ASSY-MAIN BD	1
△ 16	996510020953	ASSY-PW BD	1
19	996510020951	ASSY-KU BD	1
20	996510020957	ASSY-FB BD	1
6	996510020934	ASSY-SW BD	1
10	996510020955	DVD LOADER	1
OPU	996510020914	IM S76RFXP OPU	1

ASSY-MAIN BD COMPONENT PARTLIST

NO	12NC NO.	Description	Q'ty
D2	996510009667	SMD. SWITCHING DIODE LL4148	1
D3	996510009668	BAT54C	1
D4	996510009667	SMD. SWITCHING DIODE LL4148	1
D50	996510009667	SMD. SWITCHING DIODE LL4148	1
L10	996500014082	COIL CHOKE 10UH +/-10%	1
L9	996500014082	COIL CHOKE 10UH +/-10%	1
Q1	996510010922	ASM3402M/TR-LF SOT-23	1
Q10	996510009671	PNP TRANSISTOR	1
Q11	996510009669	SMD.TRANSISTOR MMBT3904LT1 NPN	1
Q12	996510009669	SMD.TRANSISTOR MMBT3904LT1 NPN	1
Q13	996510009670	TRANSISTOR SMT 3CG9012M	1
Q14	996510009670	TRANSISTOR SMT 3CG9012M	1
Q15	996510009669	SMD.TRANSISTOR MMBT3904LT1 NPN	1
Q16	996510009671	PNP TRANSISTOR	1
Q17	996510009671	PNP TRANSISTOR	1
Q2	996510009669	SMD.TRANSISTOR MMBT3904LT1 NPN	1
Q20	996510010949	MOSFET AO3402	1
Q21	996510009669	SMD.TRANSISTOR MMBT3904LT1 NPN	1
Q22	996510009669	SMD.TRANSISTOR MMBT3904LT1 NPN	1
Q23	996510009670	TRANSISTOR SMT 3CG9012M	1
Q24	996510009670	TRANSISTOR SMT 3CG9012M	1
Q3	996510009671	PNP TRANSISTOR	1
Q4	996510009669	SMD.TRANSISTOR MMBT3904LT1 NPN	1
Q5	996510009769	N Channel MOSFET 2SK3108	1
Q6	996510009769	N Channel MOSFET 2SK3108	1
Q7	996510009937	TRANSISTOR S8550LT1(PNP)	1
Q8	996510009937	TRANSISTOR S8550LT1(PNP)	1
U1	996510020958	MT1389DXE/M DECODE IC(NO KEY)	1
U11	996510021013	IC PESD5VL4UG	1
U2	996510011055	IC CD5888CB	1
U3	996510013349	HDMI USB ESD PYOTECTION IC	1
U4	996510013315	64M SDRAM HY57V641620FTP-7-C	1
U5	996510021491	16M SPI flash ESMT	1
U6	996510010924	Dual operational amplifier	1
Y2	996510009675	27MCL20PF	1

ASSY-PW BD COMPONENT PARTLIST

NO	12NC NO.	Description	Q'ty
D1	996510011047	DIODE IN4007	1
D10	996500027866	DIODE SR360 3A/60V	1
D2	996510011047	DIODE IN4007	1
D3	996510011047	DIODE IN4007	1
D4	996510011047	DIODE IN4007	1
D7	996500014043	DIODE FR102 (FAST RECOVERY)	1
D8	996510011047	DIODE IN4007	1
L1	996510009942	COIL WIDTH	1
L2	996500032509	COIL SL0811-6R8K2R4	1
T1	996510010954	TRANSFORMER CONV	1
U1	996510012685	IC TNY177PN	1
U2	996500027867	PHOTOCOUPLER PS2561L1-1-V(WF)	1
U3	996500014609	IC AM431LP	1

ASSY-FB BD COMPONENT PARTLIST

NO	12NC NO.	Description	Q'ty
LED1	996510020917	J2808AG	1
REM301	996510020925	HM338-12 RECEIVER MOD H=12MM	1
U301	996510009665	IC ET6202 SOP-2	1

ASSY-KU BD COMPONENT PARTLIST

NO	12NC NO.	Description	Q'ty
U200	996500032494	IC AS4558M	1

MECHANICAL PARTLIST

No	12NC No.	Description	Q'ty
11	996510020952	TOP COVER	1
△ 13	996510001537	POWER CORD	1
15	996510022347	BACK PANEL	1
17	996510006463	PAD	4
2	996510020948	FRONT DOOR	1
△ 8	996510027798	BOTTOM PLATE	1
AVCABLE	996510001106	VIDEO CABLE 1500mm	1
Assy1	996510020949	ASSY FRONT DOOR	1
CON2	996510011060	5PIN CBL TJC3-5Y/SCN-5P L=70MM	1
RC	996510020927	REMOTE CONTROL	1
SOUNDBOX	996510027797	L+R SOUND BOX & SUBWOOFER	1
XP2	996510020954	24PIN FFC CONN 0.5PITCH L:200	1
XP3	996510020961	5P CABLE PH-5Y/JC20-5P L=150MM	1
XP4	996510020921	6PIN CBL PH-6Y*2 20080#28	1
XP601	996510020962	7PIN CABLE WITH SHIELD(XP7:	1
XS301	996510010479	6PIN HS L=120MM	1

SCREWS LIST:

No	12NC No.	Description	Q'ty
7	—	S/T SCREW B 2.6 X 8 BF	6
12	—	S/T SCREW B3 X 6 BF	9
14	—	S/T SCREW B 3 X 7 BF	5

REVISION LIST

Version 1.0

* Initial release for DVP3360K/55 & DVP3360K/98

Version 1.1

* Adding DVP3360K/75

Version 1.2

* Adding HTP3360K/98

Version 1.3

* Update P8-2 partlist,

SOUNDBOX 996510027797 L+R SOUND BOX & SUBWOOFER (WAS SOUND BOX)