



SERVICE MANUAL

MODEL : DK678XB(DV183KEM)



# DVD VIDEO PLAYER

## SERVICE MANUAL

MODEL : DK678XB(DV183KEM)

**CAUTION**  
BEFORE SERVICING THE UNIT, READ THE "SAFETY PRECAUTIONS"  
IN THIS MANUAL.

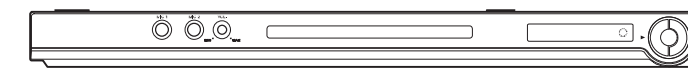

LG Electronics Inc.

# CIRCUIT DIAGRAMS

## 1. POWER(SMPS) CIRCUIT DIAGRAM

### IMPORTANT SAFETY NOTICE

WHEN SERVICING THIS CHASSIS, UNDER NO CIRCUMSTANCES SHOULD THE ORIGINAL DESIGN BE MODIFIED OR ALTERED WITHOUT PERMISSION FROM THE LG ELECTRONICS CORPORATION. ALL COMPONENTS SHOULD BE REPLACED ONLY WITH TYPES IDENTICAL TO THOSE IN THE ORIGINAL CIR-

CUIT. SPECIAL COMPONENTS ARE SHADED ON THE SCHEMATIC FOR EASY IDENTIFICATION.

THIS CIRCUIT DIAGRAM MAY OCCASIONALLY DIFFER FROM THE ACTUAL CIRCUIT USED. THIS WAY, IMPLEMENTATION OF THE LATEST SAFETY AND PERFORMANCE IMPROVEMENT CHANGES INTO THE SET IS NOT DELAYED UNTIL THE NEW SERVICE LITERATURE IS PRINTED.

### NOTE :

1. Shaded(■) parts are critical for safety. Replace only with specified part number.
2. Voltages are DC-measured with a digital voltmeter during Play mode.

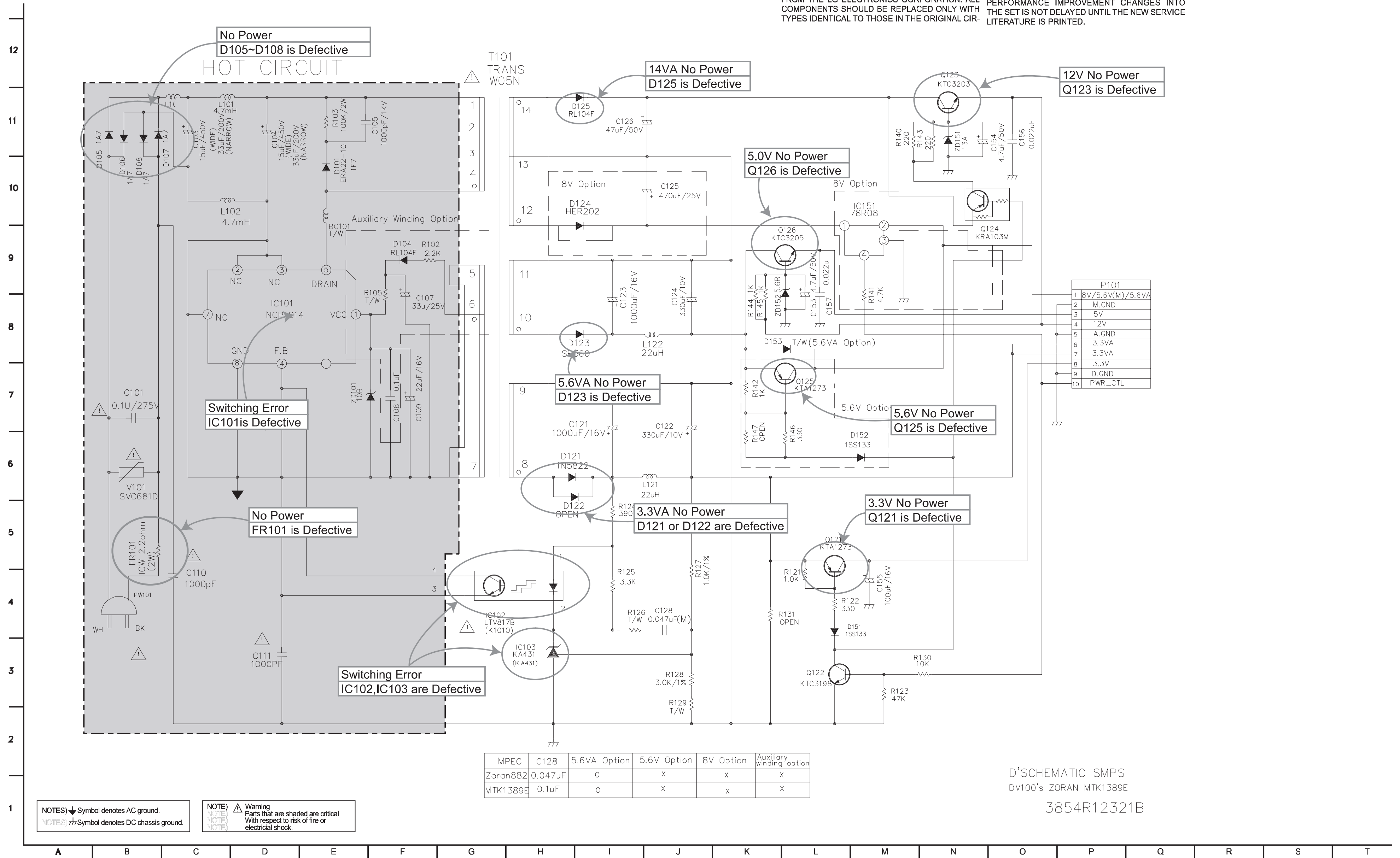

NOTES) ⚡ Symbol denotes AC ground.  
 NOTES) ⚡ Symbol denotes DC chassis ground.  
 NOTE) ⚠ Warning Parts that are shaded are critical With respect to risk of fire or electrical shock.

D'SCHEMATIC SMPS  
 DV100's ZORAN MTK1389E  
 3854R12321B

## 2. SYSTEM CIRCUIT DIAGRAM

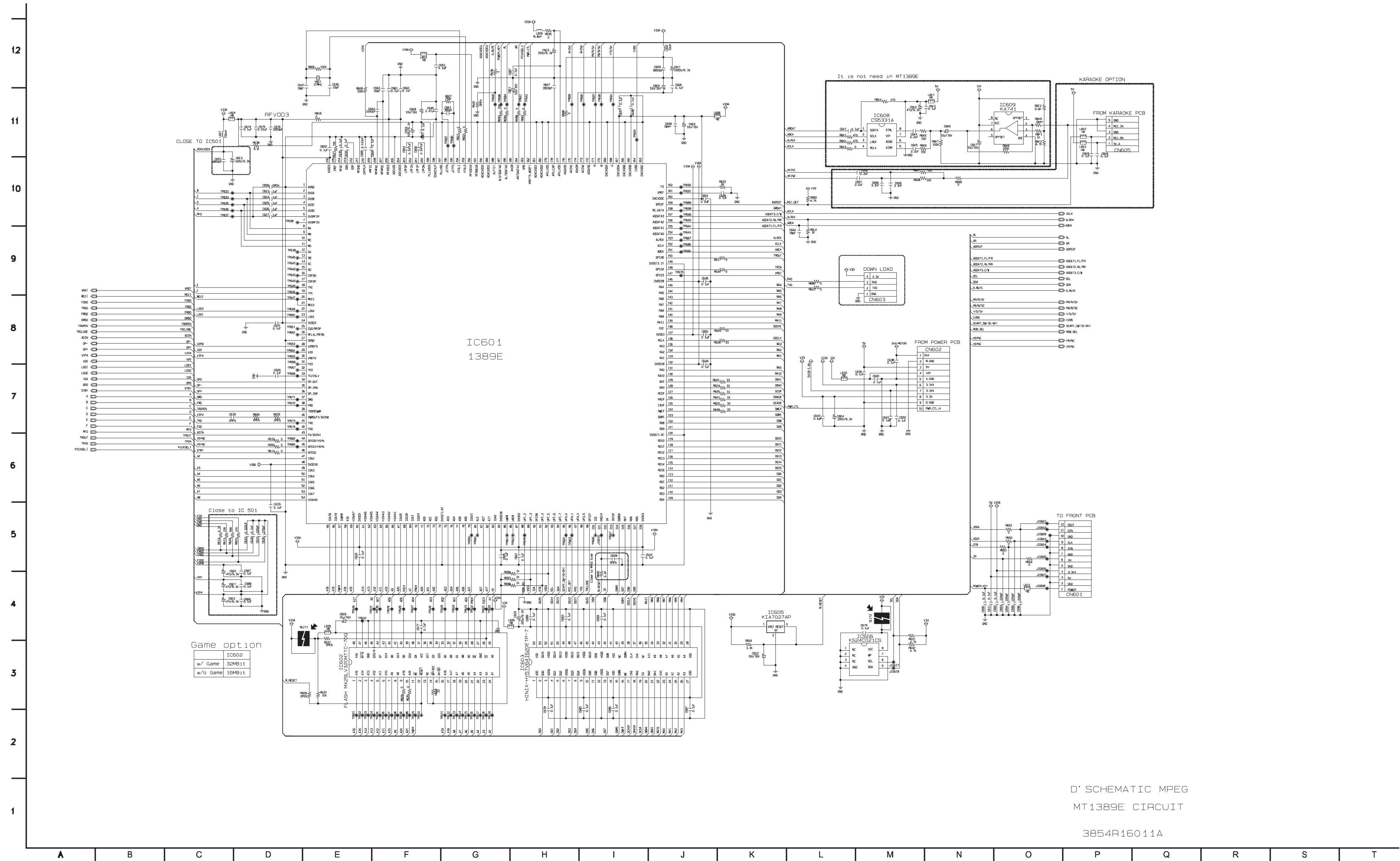

### 3. SERVO CIRCUIT DIAGRAM

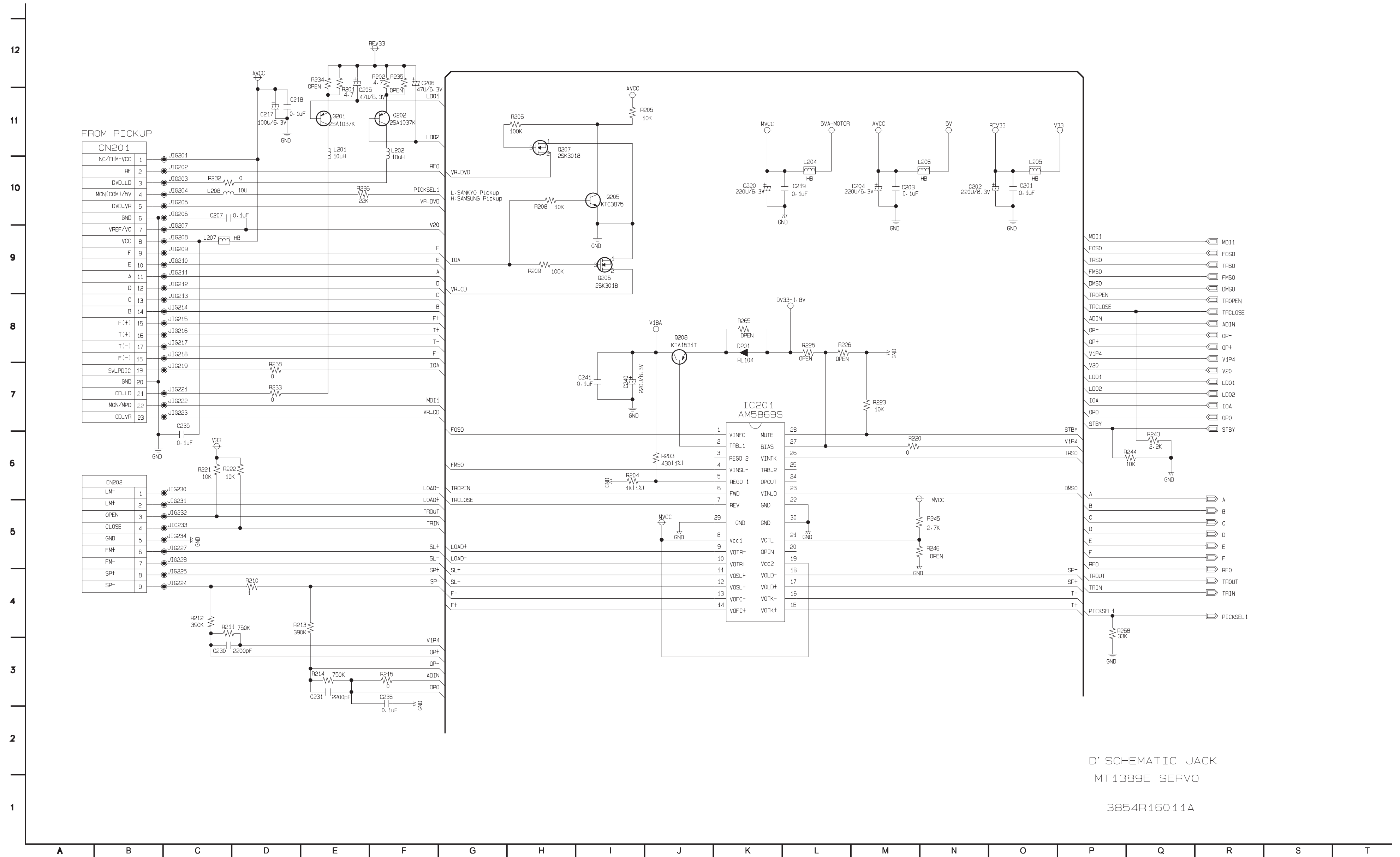

D' SCHEMATIC JACK  
MT1389E SERVO

3854R16011A

# 4. AV/JACK CIRCUIT DIAGRAM

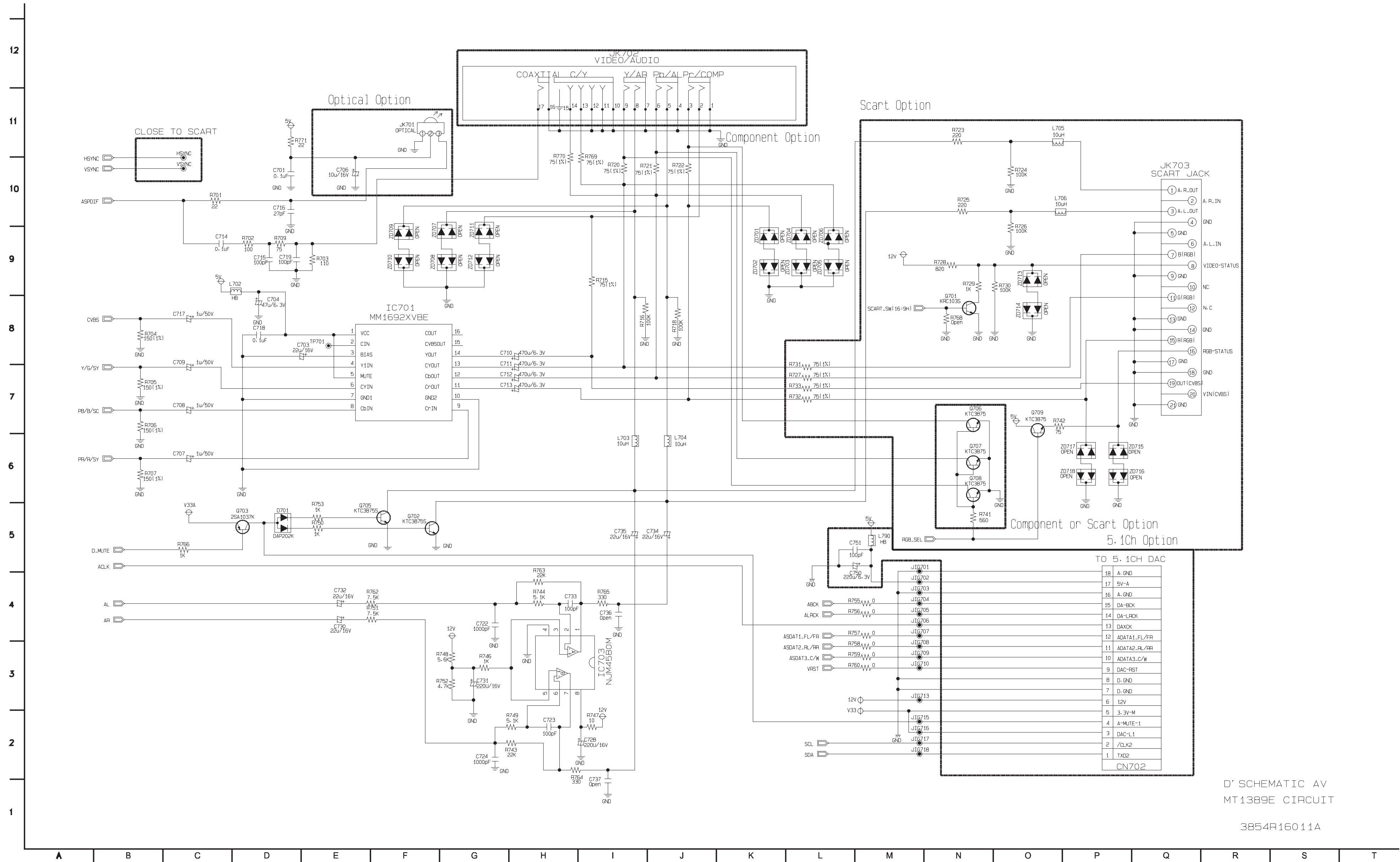

D' SCHEMATIC AV  
MT1389E CIRCUIT  
3854R16011A

## 5. TIMER CIRCUIT DIAGRAM ( 3 TOOL ONLY )

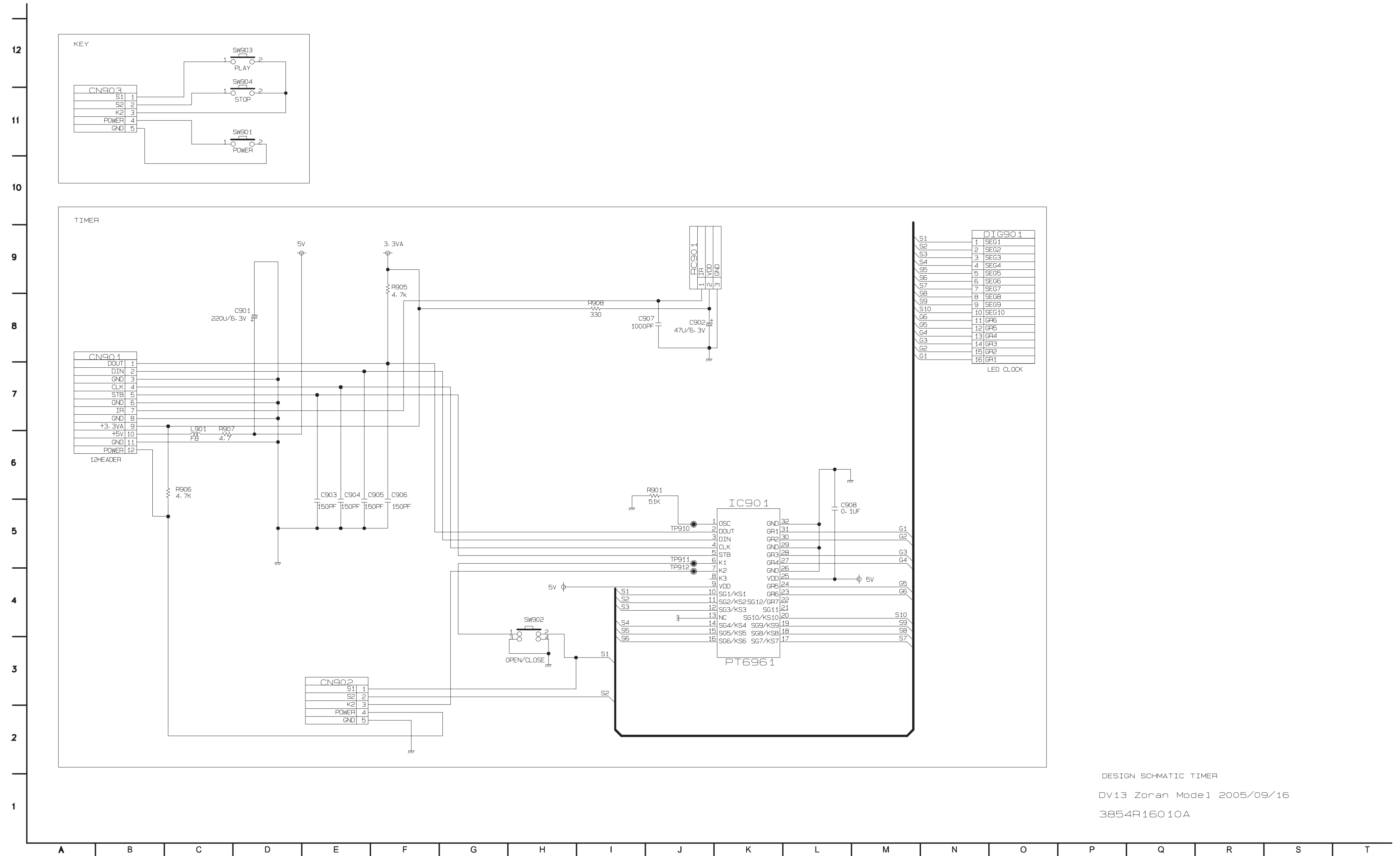

DESIGN SCHEMATIC TIMER  
 DV13 Zoran Mode1 2005/09/16  
 3854R16010A



## 6. TIMER CIRCUIT DIAGRAM ( 4 TOOL ONLY )

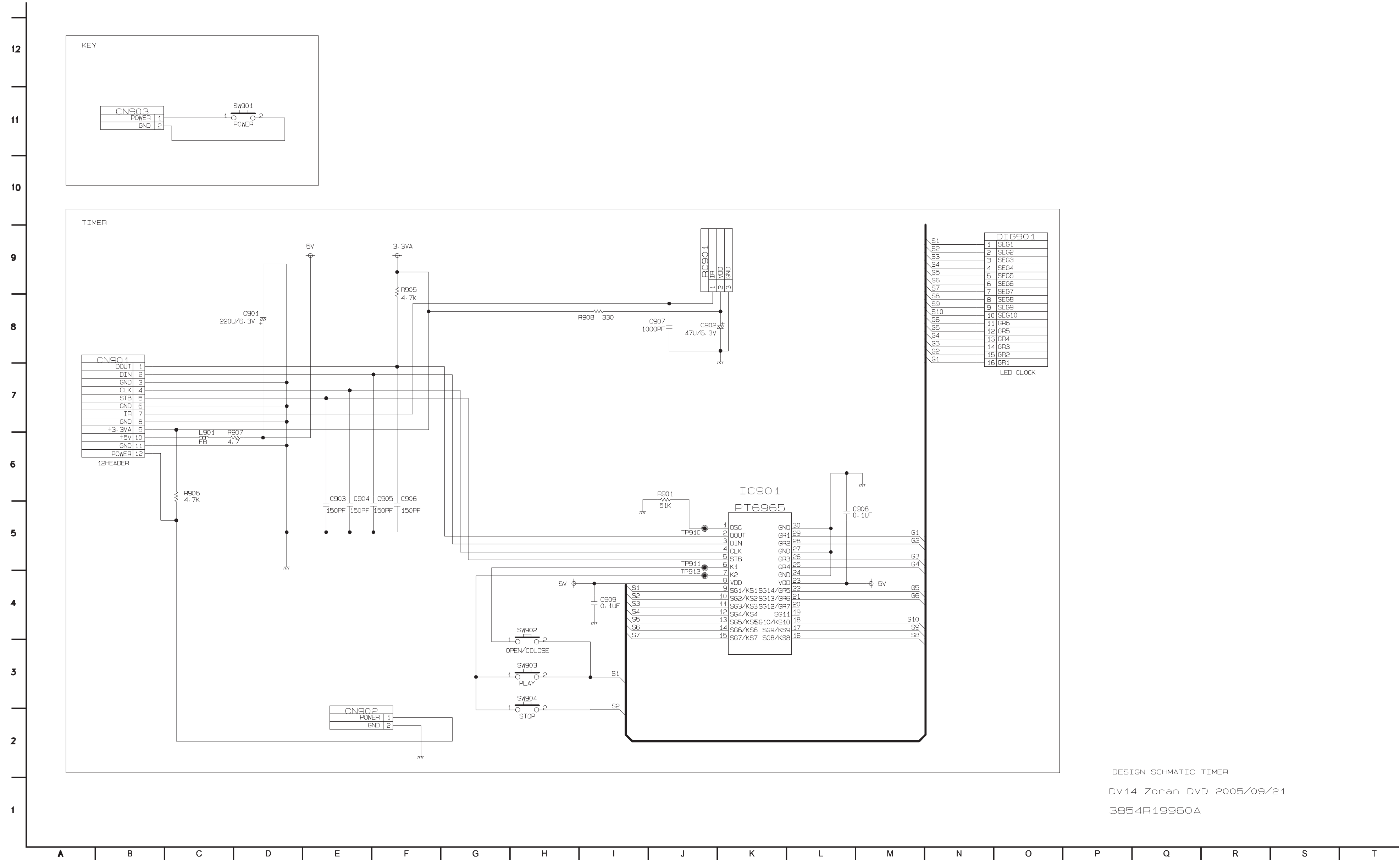

DESIGN SCHEMATIC TIMER  
DV14 Zoran DVD 2005/09/21  
3854R19960A

# 7. TIMER CIRCUIT DIAGRAM ( 6 TOOL ONLY )

12  
11  
10  
9  
8  
7  
6  
5  
4  
3  
2  
1

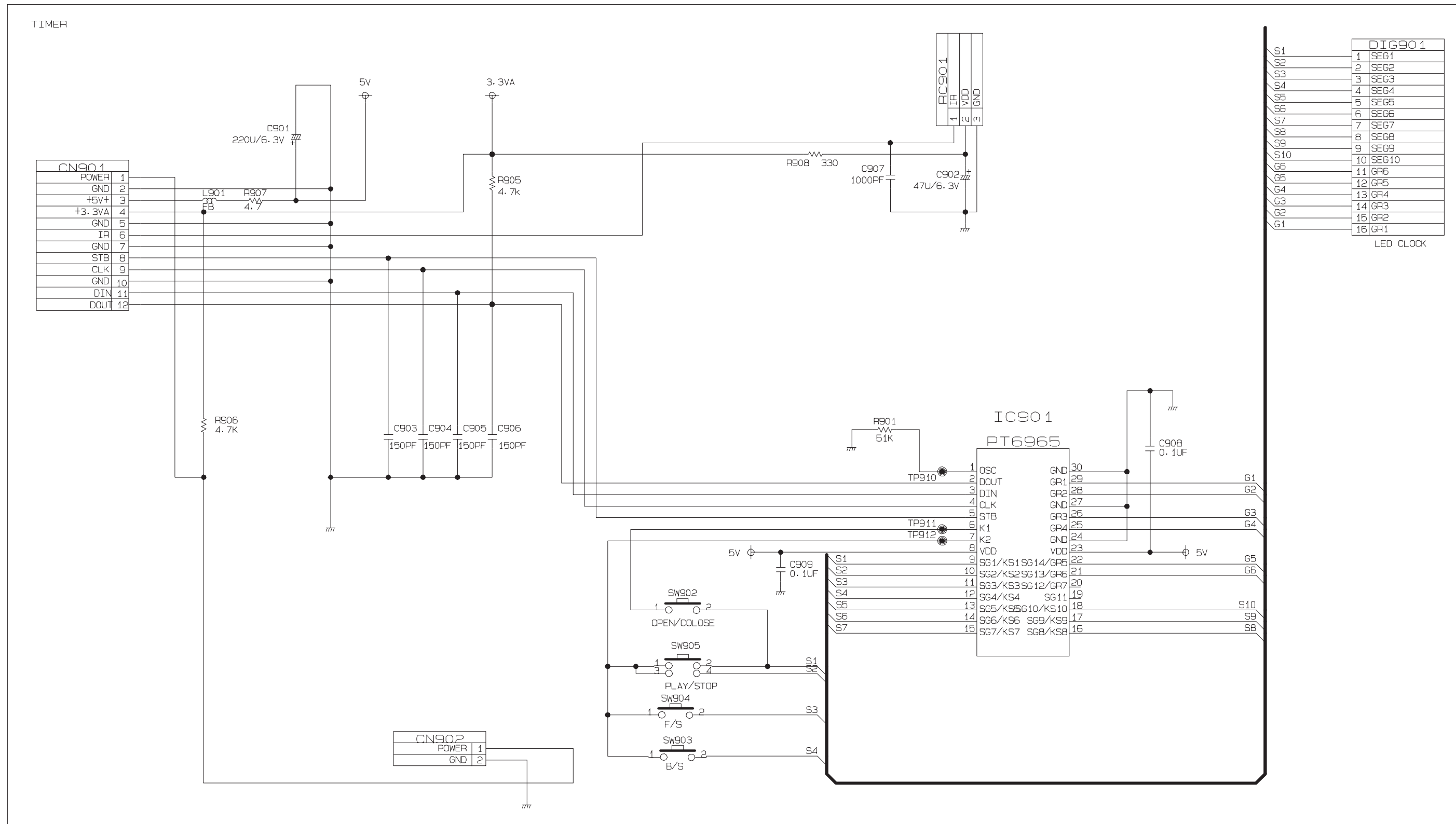
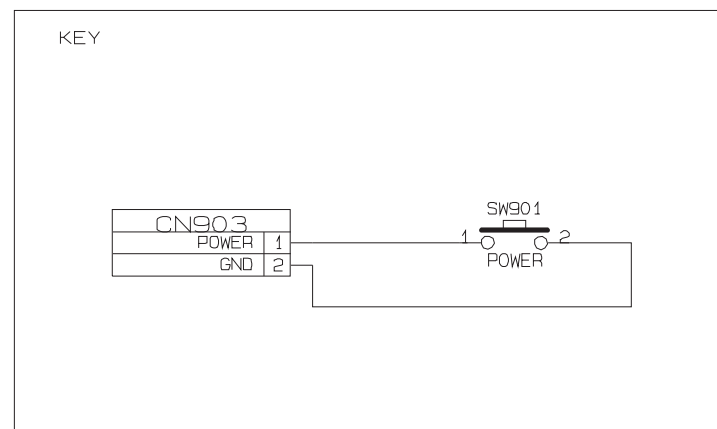

DIG901	
1	SEG1
2	SEG2
3	SEG3
4	SEG4
5	SEG5
6	SEG6
7	SEG7
8	SEG8
9	SEG9
10	SEG10
11	GR6
12	GR5
13	GR4
14	GR3
15	GR2
16	GR1

LED CLOCK

A B C D E F G H I J K L M N O P Q R S T



# 8. TIMER CIRCUIT DIAGRAM ( 7 TOOL ONLY )

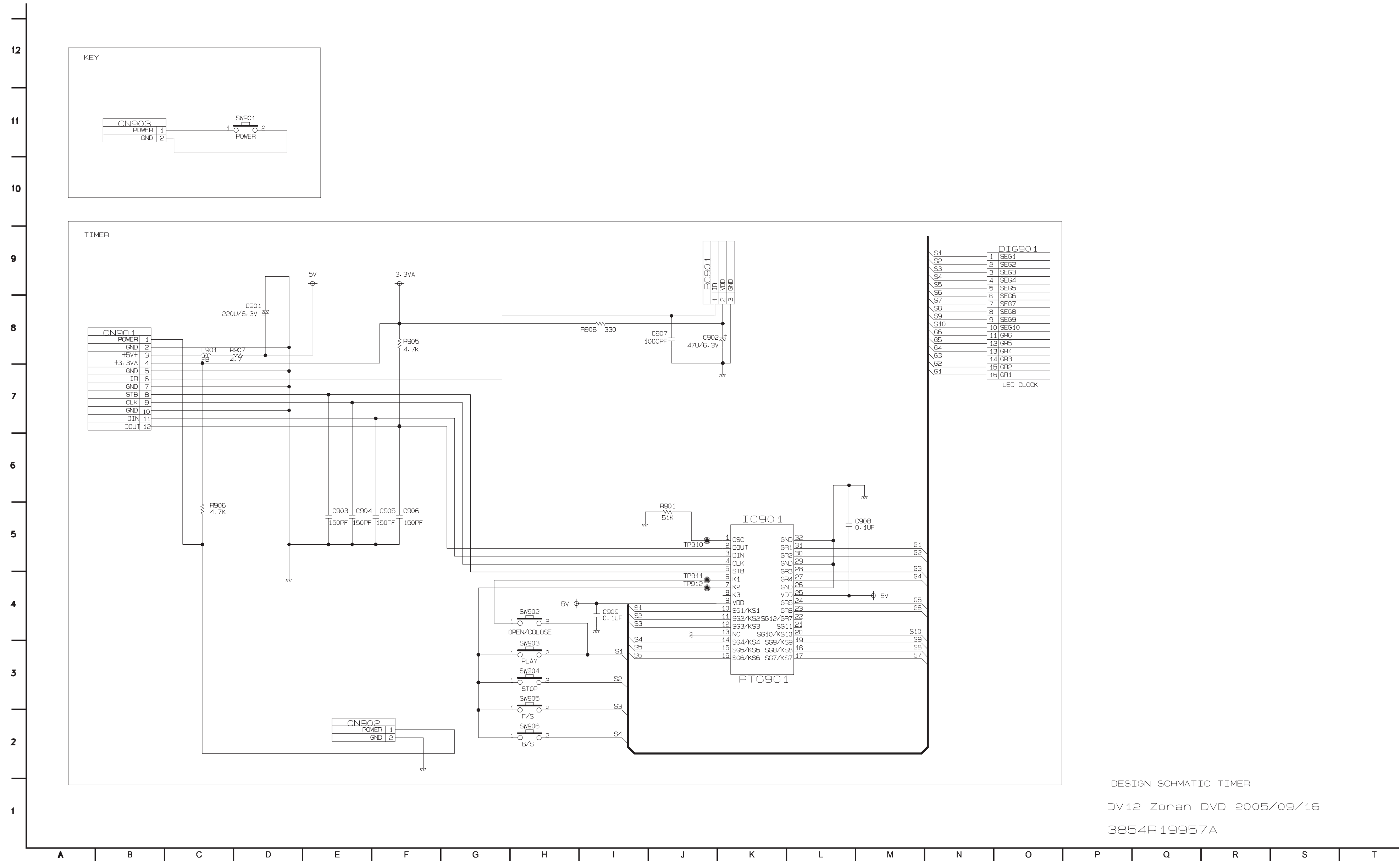

DESIGN SCHMATIC TIMER  
 DV.12 Zoran DVD 2005/09/16  
 3854R19957A

# 9. TIMER CIRCUIT DIAGRAM ( 8 TOOL ONLY )

12  
11  
10  
9  
8  
7  
6  
5  
4  
3  
2  
1

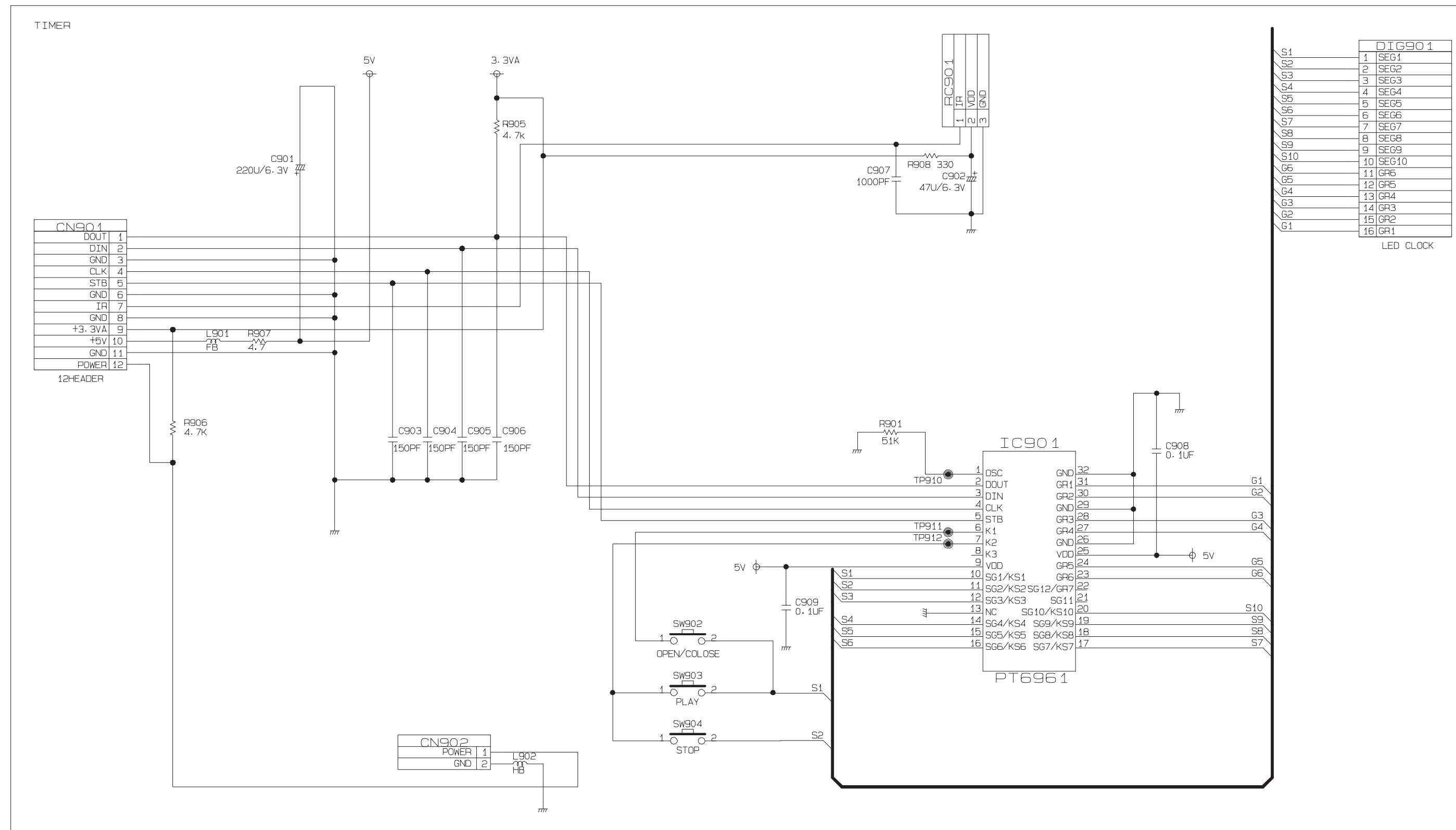
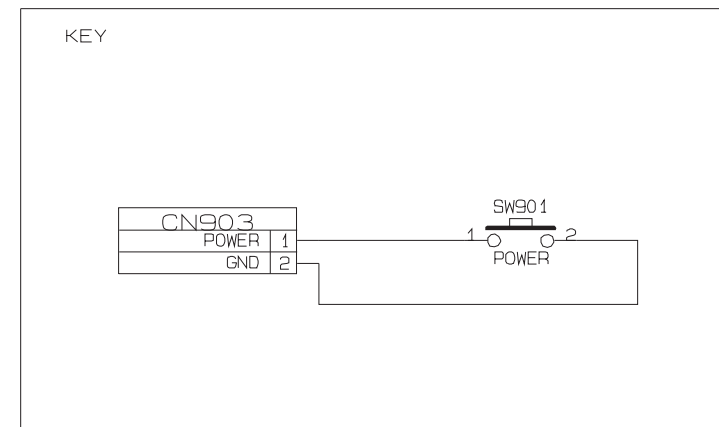

DESIGN SCHEMATIC TIMER  
DV19 Zoran DVD 2005/09/16  
3854R19956A

A B C D E F G H I J K L M N O P Q R S T

# 10. KARAOKE CIRCUIT DIAGRAM (KARAOKE MODEL ONLY)

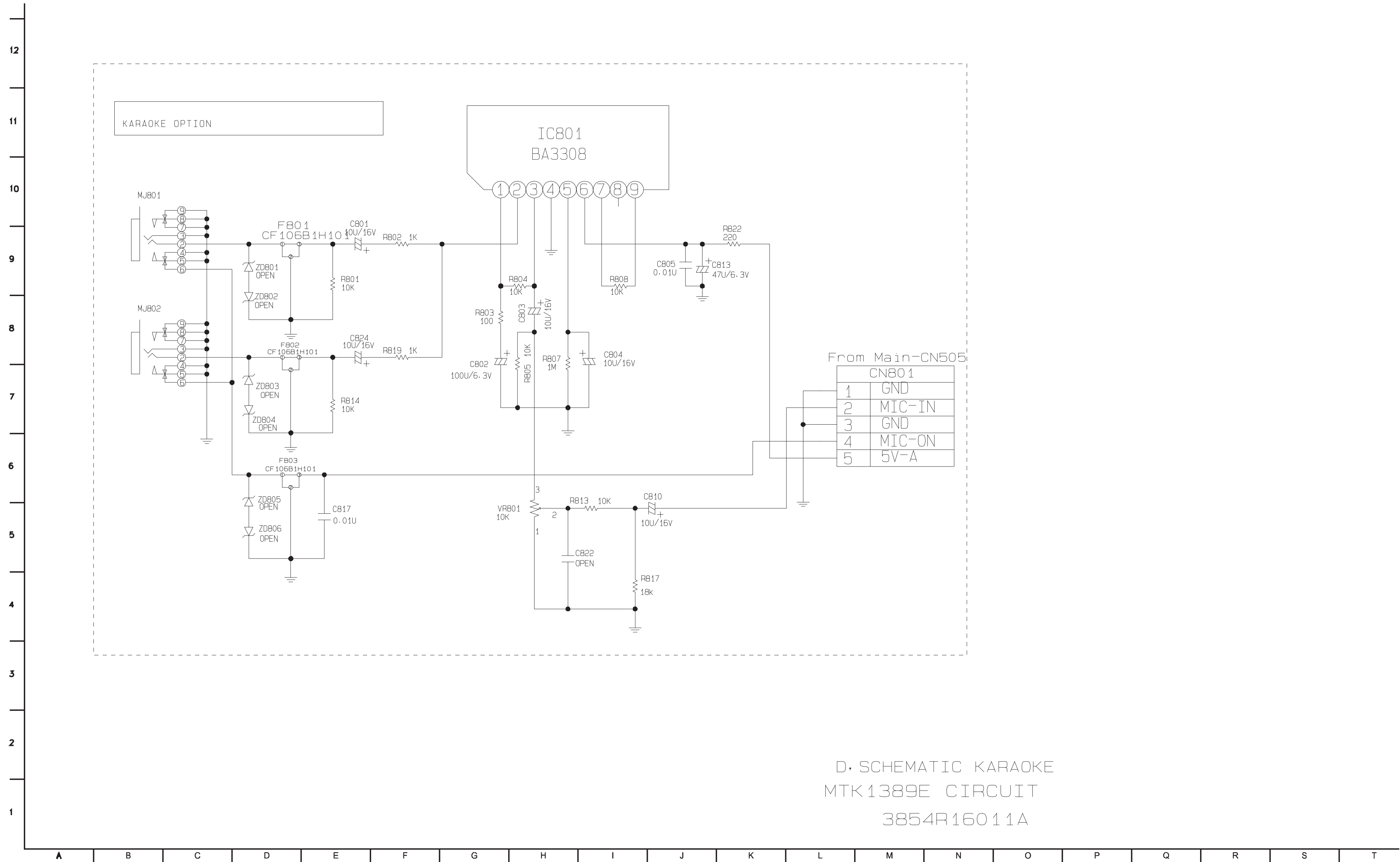

D. SCHEMATIC KARAOKE  
MTK1389E CIRCUIT  
3854R16011A