



Magnat

Magnat

PHANTOM

4000

4 CH AMP

LINE INPUT  
RCA

POWER

LINE

LINE

LINE

LINE

LINE

LINE

LINE OUT

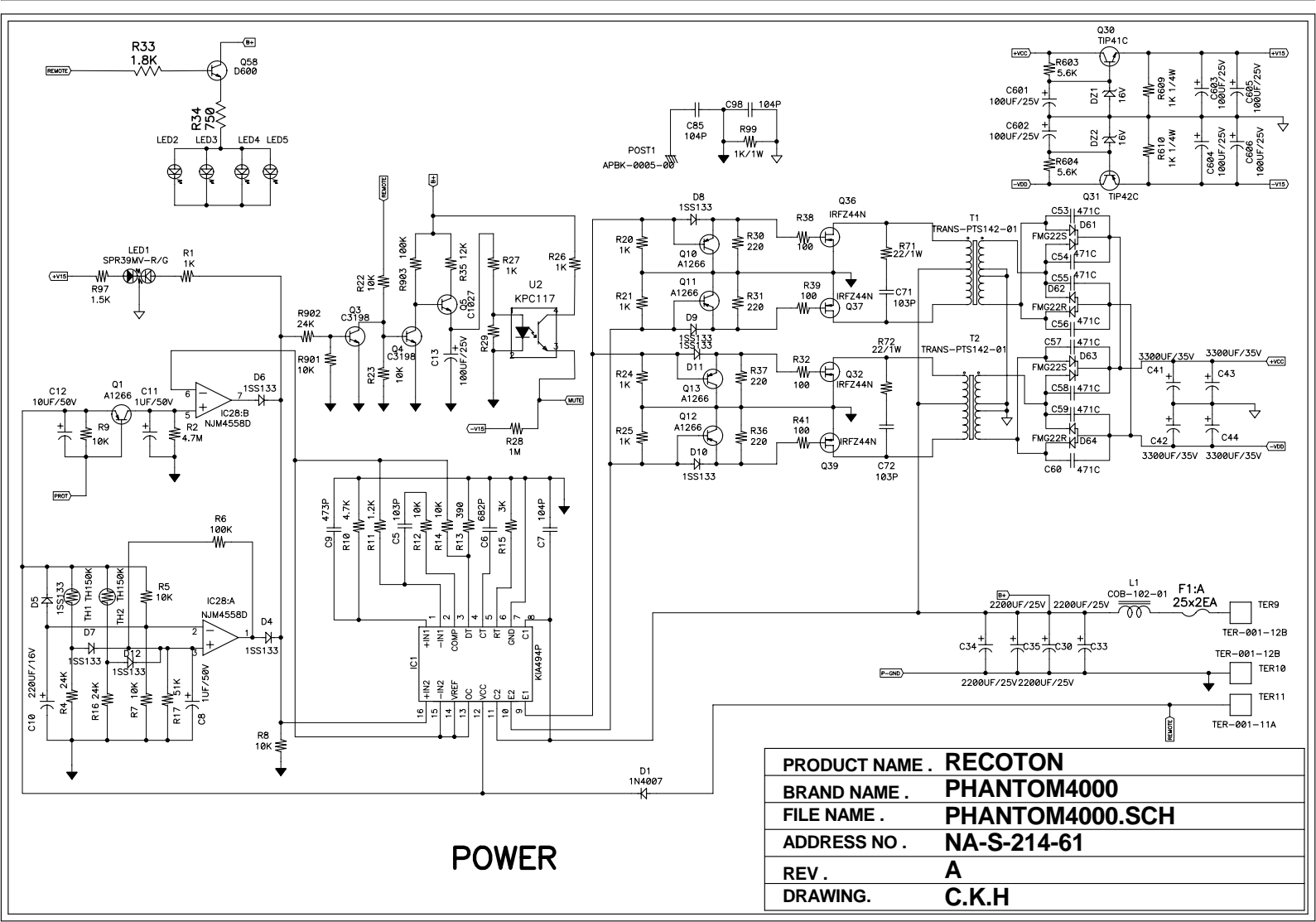
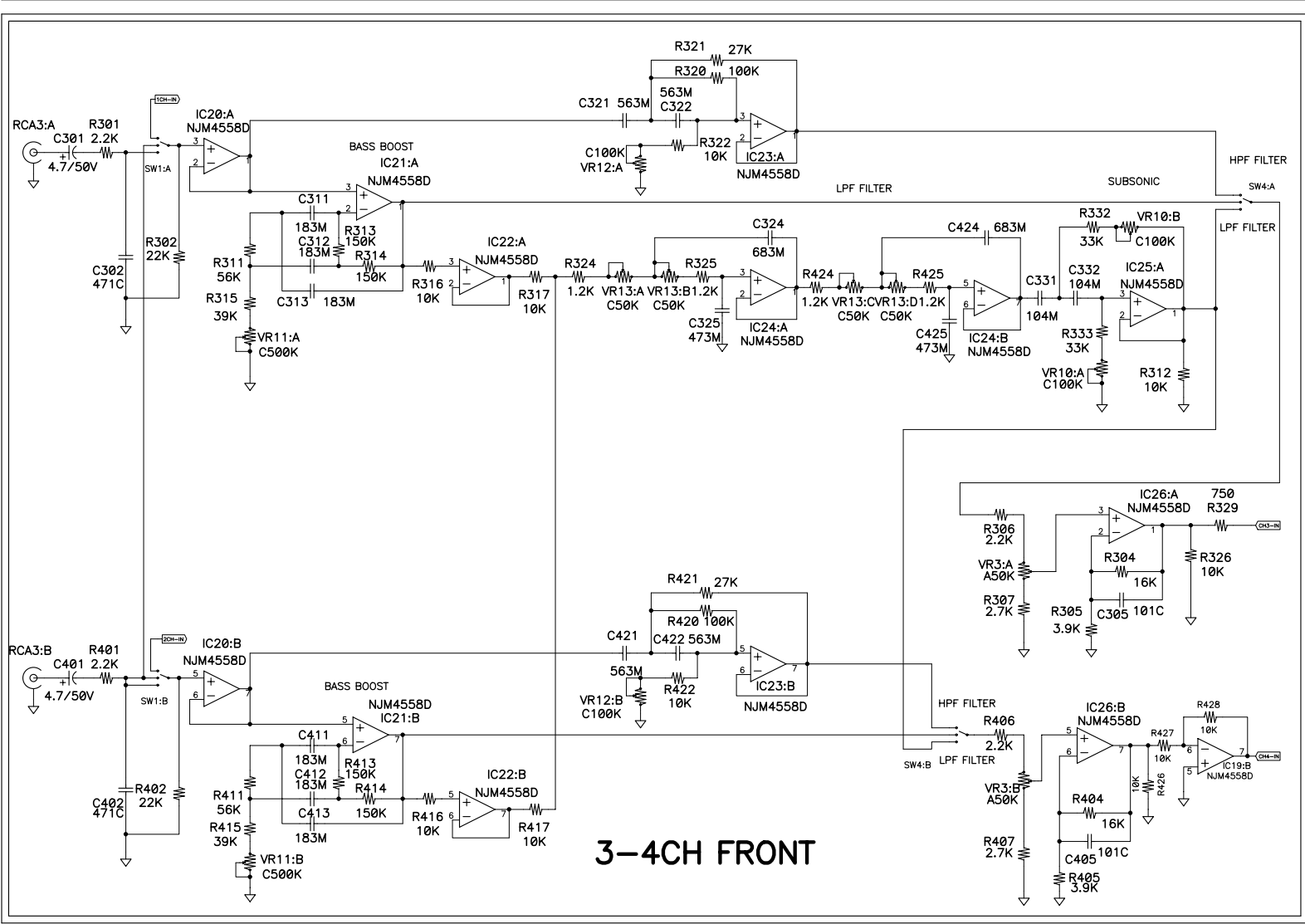
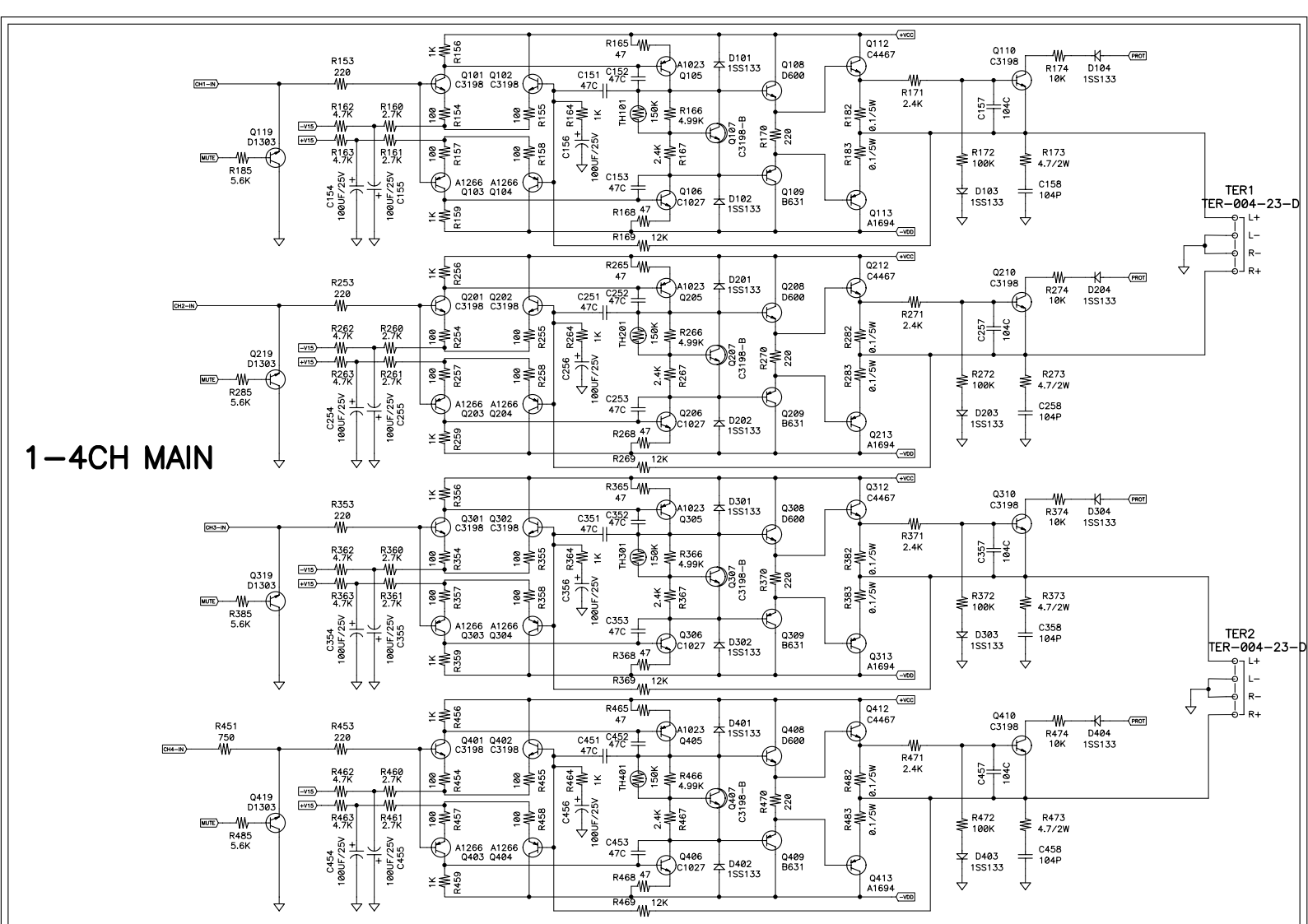
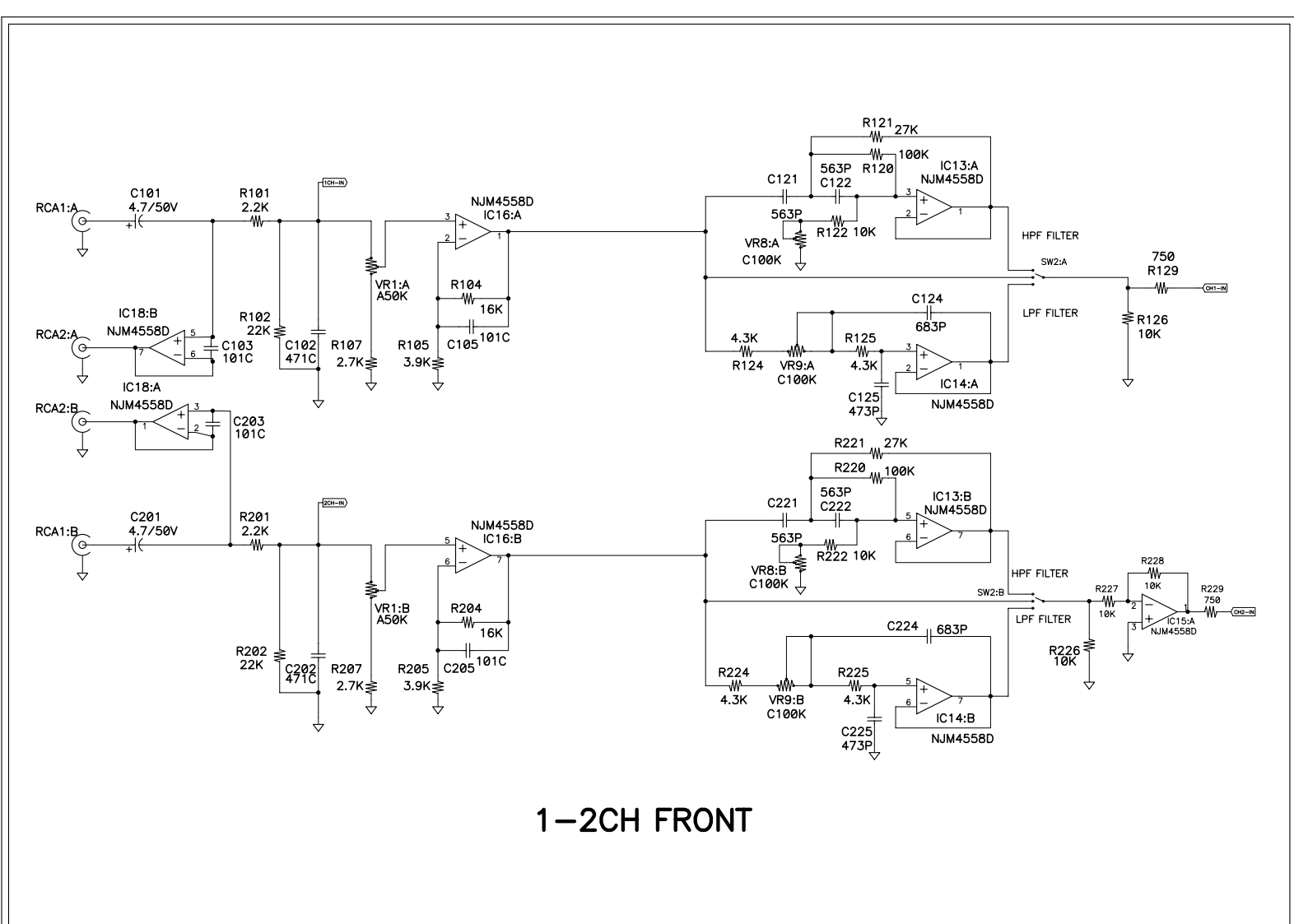

PRODUCT NAME .	RECOTON
BRAND NAME .	PHANTOM4000
FILE NAME .	PHANTOM4000.SCH
ADDRESS NO .	NA-S-214-61
REV .	A
DRAWING .	C.K.H

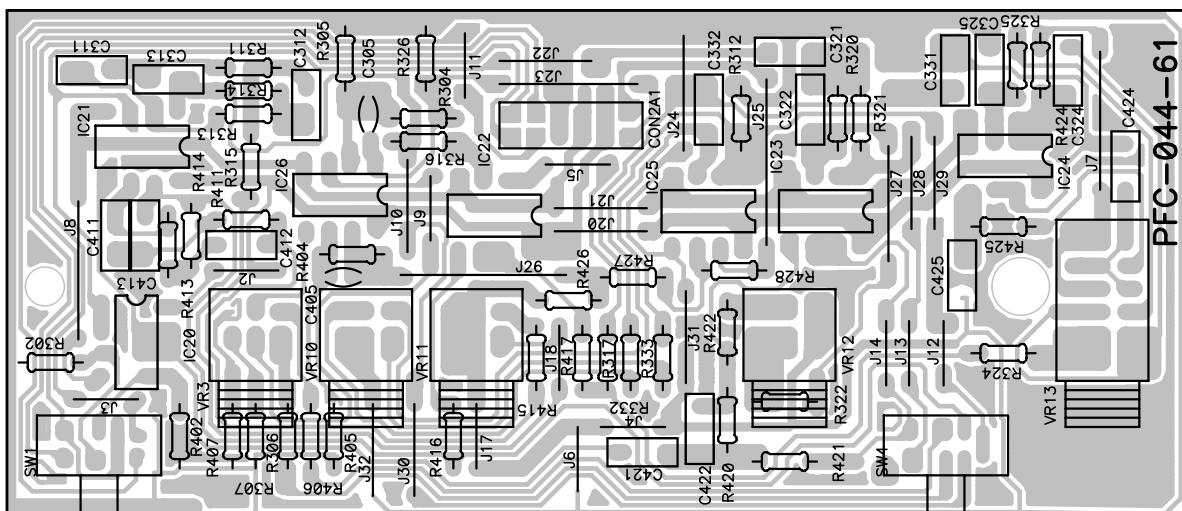
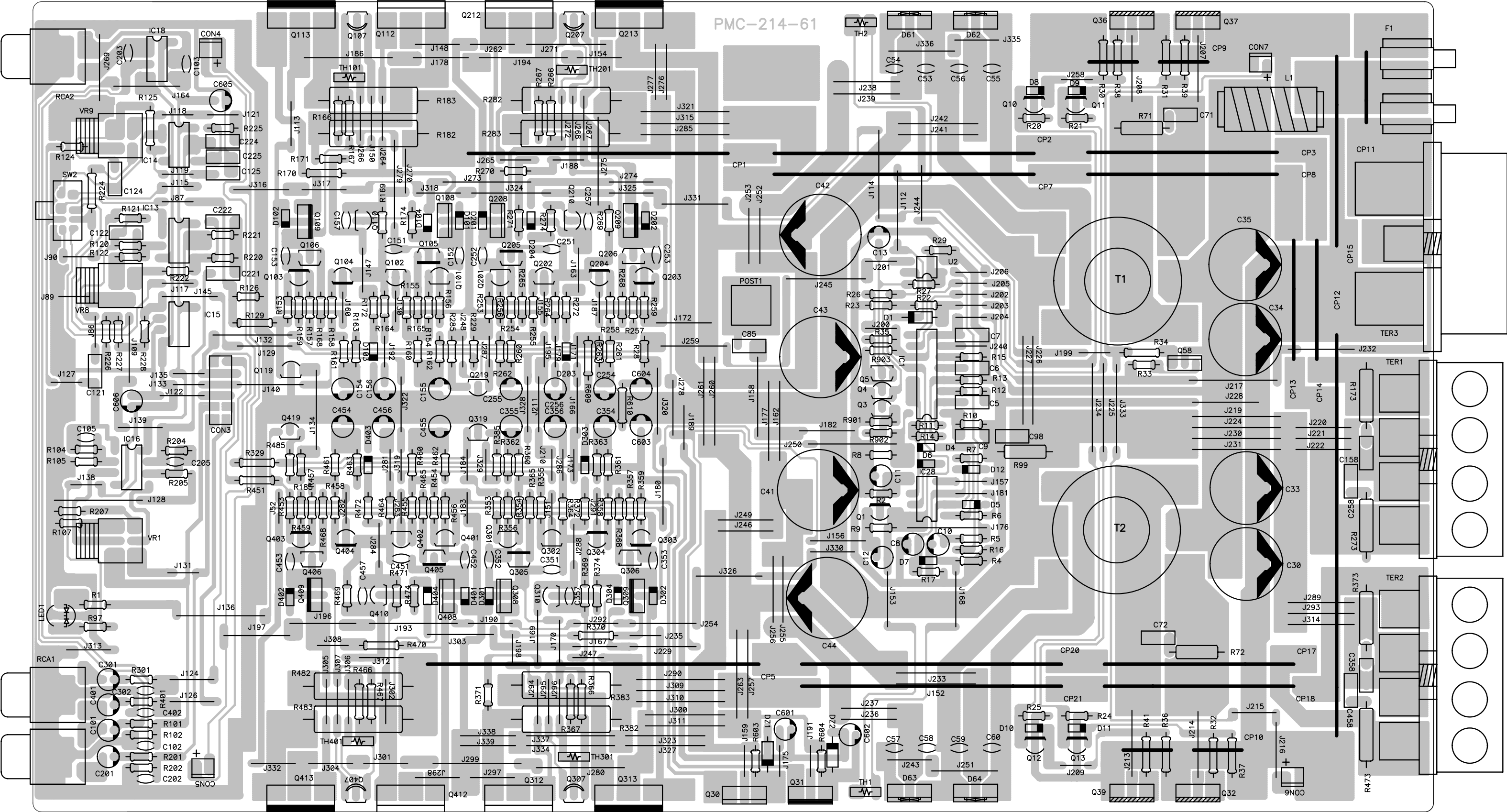

<b>TOP VIEW.</b>	
<b>PRODUCT NAME.</b>	<b>RECOTON</b>
<b>BRAND NAME .</b>	<b>PHANTOM4000</b>
<b>FILE NAME .</b>	<b>PHANTOM4000.PCB</b>
<b>ADDRESS NO .</b>	<b>NA-P-214-01</b>
<b>REV .</b>	<b>A</b>
<b>DRAWING.</b>	<b>C.K.H</b>



# PHANTOM 4000

CODE	ITEM	SPEC		Q ' TY	LOCATION
<b>&lt; ELECTRONIC - MAIN &gt;</b>					
CCEF-101SL-T	CERAMIC CAPACITOR	100pF/50V 5% SL +5	TAPPING	4.000	C103,C105,C203,C205
CCEF-104FZ-T	CERAMIC CAPACITOR	0.1uF/50V 5% FZ +5	TAPPING	4.000	C157,C257,C357,C457
CCEF-470CH-T	CERAMIC CAPACITOR	47pF/50V 5% CH +5	TAPPING	12.000	C151,C152,C153,C251,C252,C253,C351,C352,C353,C451,C452,C453
CCEF-471BK-T	CERAMIC CAPACITOR	470pF/50V 5% BK +5	TAPPING	12.000	C53,C54,C55,C56,C57,C58,C59,C60,C102,C202,C302,C402
CMAI-103J-T	MYLAR CAPACITOR	0.01uF/100V 5%	TAPPING	3.000	C5,C71,C72
CMAI-104J-T	MYLAR CAPACITOR	0.1uF/100V 5%	TAPPING	7.000	C7,C85,C98,C158,C258,C358,C458
CMAI-682J-T	MYLAR CAPACITOR	0.0068uF/100V 5%	TAPPING	1.000	C6
CMFG-473-2572-T	MPF CAPACITOR	0.047uF/63V 5%	TAPPING 7.2x6.5x2.5	3.000	C9,C125,C225
CMFG-563-2572-T	MPF CAPACITOR	0.056uF/63V 5%	TAPPING 7.2x6.5x2.5	4.000	C121,C122,C221,C222
CMFG-683-2572-T	MPF CAPACITOR	0.068uF/63V 5%	TAPPING 7.2x6.5x2.5	2.000	C124,C224
DIODE-1N4007	DIODE	1N4007		1.000	D1
DIODE-1N4745	ZENER DIODE	1N4745 16V 1W		2.000	DZ1,DZ2
DIODE-1SS133	DIODE	1SS133/1N4148		25.000	D4,5,6,7,8,9,10,11,12,101,102,103,104,201,202,203,204,301,302,303,304,401,402,403,404
JUMP-52-07	JUMP WIRE	52mm +0.7 TAPPING		216.000	
PCB-PMC214-61	MAIN PCB	PMC-214-61 (BLUE)		1.000	
RES1/4-102	RESISTOR	RES 1/4W 1K ohm		2.000	R609,R610
RES1/8-101	RESISTOR	RES 1/8W 100 ohm		20.000	R32,R38,R39,R41,R154,R155,R157,R158,R254,R255,R257,R258,R354,R355,R357,R358,R454,R455,R457,R458
RES1/8-102	RESISTOR	RES 1/8W 1K ohm		19.000	R1,R20,R21,R24,R25,R26,R27,R156,R159,R164,R256,R259,R264,R356,R359,R364,R456,R459,R464
RES1/8-103	RESISTOR	RES 1/8W 10K ohm		19.000	R5,R7,R8,R9,R12,R14,R22,R23,R122,R126,R174,R222,R226,R227,R228,R274,R374,R474,R901
RES1/8-104	RESISTOR	RES 1/8W 100K ohm		8.000	R6,R120,R172,R220,R272,R372,R472,R903
RES1/8-105	RESISTOR	RES 1/8W 1M ohm		1.000	R28
RES1/8-122	RESISTOR	RES 1/8W 1.2K ohm		1.000	R11
RES1/8-123	RESISTOR	RES 1/8W 12K ohm		5.000	R35,R169,R269,R369,R469
RES1/8-152	RESISTOR	RES 1/8W 1.5K ohm		1.000	R97
RES1/8-163	RESISTOR	RES 1/8W 16K ohm		2.000	R104,R204
RES1/8-182	RESISTOR	RES 1/8W 1.8K ohm		1.000	R33
RES1/8-221	RESISTOR	RES 1/8W 220 ohm		12.000	R30,R31,R36,R37,R153,R170,R253,R270,R353,R370,R453,R470
RES1/8-222	RESISTOR	RES 1/8W 2.2K ohm		4.000	R101,R201,R301,R401
RES1/8-223	RESISTOR	RES 1/8W 22K ohm		2.000	R102,R202
RES1/8-242	RESISTOR	RES 1/8W 2.4K ohm		8.000	R167,R171,R267,R271,R367,R371,R467,R471
RES1/8-243	RESISTOR	RES 1/8W 24K ohm		3.000	R4,R16,R902
RES1/8-272	RESISTOR	RES 1/8W 2.7K ohm		10.000	R107,R160,R161,R207,R260,R261,R360,R361,R460,R461
RES1/8-273	RESISTOR	RES 1/8W 27K ohm		2.000	R121,R221
RES1/8-302	RESISTOR	RES 1/8W 3K ohm		1.000	R15
RES1/8-391	RESISTOR	RES 1/8W 390 ohm		1.000	R13
RES1/8-392	RESISTOR	RES 1/8W 3.9K ohm		2.000	R105,R205
RES1/8-432	RESISTOR	RES 1/8W 4.3K ohm		4.000	R124,R125,R224,R225
RES1/8-470	RESISTOR	RES 1/8W 47 ohm		8.000	R165,R168,R265,R268,R365,R368,R465,R468
RES1/8-472	RESISTOR	RES 1/8W 4.7K ohm		9.000	R10,R162,R163,R262,R263,R362,R363,R462,R463

# PHANTOM 4000

CODE	ITEM	SPEC	Q'TY	LOCATION
RES1/8-475	RESISTOR	RES 1/8W 4.7M ohm	1.000	R2
RES1/8-4991	RESISTOR	RES 1/8W 4.99K ohm	4.000	R166,R266,R366,R466
RES1/8-513	RESISTOR	RES 1/8W 51K ohm	1.000	R17
RES1/8-562	RESISTOR	RES 1/8W 5.6K ohm	6.000	R185,R285,R385,R485,R603,R604
RES1/8-751	RESISTOR	RES 1/8W 750 ohm	5.000	R34,R129,R229,R329,R451
CEAC-221A0611T2	ELECTROLYTIC AL. CAP	220uF/16V +85 6.3x11	1.000	C10
CEAD-101A0611T2	ELECTROLYTIC AL. CAP	100uF/25V +85 6.3x11	19.000	C13,C154,C155,C156,C254,C255,C256,C354,C355,C356,C454,C455,C456,C601,C602,C603,C604,C605,C606
CEAF-010A0511T2	ELECTROLYTIC AL. CAP	1uF/50V +85 5x11	2.000	C8,C11
CEAF-100A0511T2	ELECTROLYTIC AL. CAP	10uF/50V +85 5x11	1.000	C12
CEAF-4R7A0511T2	ELECTROLYTIC AL. CAP	4.7uF/50V +85 5x11	4.000	C101,C201,C301,C401
RES1W-102M	RESISTOR	RES 1W MINI 1K ohm	1.000	R99
RES1W-220M	RESISTOR	RES 1W MINI 22 ohm	2.000	R71,R72
TR-KTA1023-T	TRANSISTOR	KTA1023 TAPPING	4.000	Q105,Q205,Q305,Q405
TR-KTA1266-T	TRANSISTOR	KTA1266 TAPPING	13.000	Q1,Q10,Q11,Q12,Q13,Q103,Q104,Q203,Q204,Q303,Q304,Q403,Q404
TR-KTC1027-T	TRANSISTOR	KTC1027 TAPPING	5.000	Q5,Q106,Q206,Q306,Q406
TR-KTC3198-T	TRANSISTOR	KTC3198 TAPPING	14.000	Q3,Q4,Q101,Q102,Q110,Q201,Q202,Q210,Q301,Q302,Q310,Q401,Q402,Q410
TR-KTD1303-T	TRANSISTOR	KTD1303 TAPPING	4.000	Q119,Q219,Q319,Q419
APBK-0005-00	PCB SUPPORT	t=1.0 (Sn...)	1.000	POST1
BART-132-01	COPPER TRACE	0.8t 32mm	2.000	CP9,CP10
BART-132-02	COPPER TRACE	0.8t 32mm	2.000	CP13,CP14
BART-148-03	COPPER TRACE	0.8t 48mm	4.000	CP3,CP8,CP17,CP18
BART-164-06	COPPER TRACE	0.8t 64mm	5.000	CP1,CP2,CP7,CP20,CP21
BART-180-10	COPPER TRACE	0.8t 80mm	1.000	CP5
BART-196-03	COPPER TRACE	0.8t 96mm	1.000	CP12
BART-221-01	COPPER TRACE	1.6t 21mm	1.000	CP11
BART-148-01	COPPER TRACE	0.8t 48mm	1.000	CP15
COIL-COB102-01	BAR CHOKE COIL	COB-102-01	1.000	L1
CORE-RING-29	CORE RING	*29x3T	2.000	
FHD-002-03	FUSE HOLDER	DKF08021/F30440110P	1.000	F1
IC-NJM4558D	OP AMP IC	NJM4558D (DIP-8)	6.000	IC13,IC14,IC15,IC16,IC18,IC28
LED-SPR39MV	LED *3 2COLOR	SPR39MV	1.000	LED1
PAD-HF425-01	SILICON PAD	..: 1.0mm ..: 2.3mm	43.000	
RCA2-004-02	2P RCA JACK	JE0200591N	1.000	RCA2
RCA4-004-02	4P RCA JACK	RCA4-004-02	1.000	RCA1
SWL-2C3P-05	SLIDE SWITCH	SK-23D04-G-G 9mm	1.000	SW2
TH-E-150K	THERMISTOR	150K NON LUG	4.000	TH101,TH201,TH301,TH401
TH-M-150K	THERMISTOR	150K ...	2.000	TH1,TH2
TRANS-PTS142-01	POWER TRANS	*29-0.8x4*6-1.4x2*12	2.000	T1,T2
VR09-2016	MAIN VOLUME	15RS 15A 50K ohm 2. RV095 GB Co	1.000	VR1
VR09-2026	MAIN VOLUME	15RS 15C 100Kohm 2.	2.000	VR8,VR9

## PHANTOM 4000

CODE	ITEM	SPEC		Q ' TY	LOCATION
WAFER-M5267-02	WAFER	M5267-02		4.000	CON4,CON5,CON6,CON7
WAFER-TSS254-12	WAFER	TSS-254-12A		1.000	CON3
CEAD-222B1625T7	ELECTROLYTIC AL. CAP	2200uF/25V 16x25	+105 7.5mm BULK KME	4.000	C30,C33,C34,C35
CEAE-332A1825T7	ELECTROLYTIC AL. CAP	3300uF/35V 18x24.5	+85 7.5mm BULK SRF	4.000	C41,C42,C43,C44
FET-IRFZ44N	FET	IRFZ44N		4.000	Q32,Q36,Q37,Q39
FUSE-25A-10021	AUTO FUSE	25A PAT10021		2.000	F1
IC-KIA494P	PWM IC	KIA494P (DIP-16)		1.000	IC1
PHOTO-KPC117	PHOTO COUPLE	KPC117		1.000	U2
RES2W-4R7M	RESISTOR	RES 2W MINI 4.7 ohm		4.000	R173,R273,R373,R473
RES5W-R10WIRE	RESISTOR	RES 5W 0.1 ohm WIRE	6mm FORMING	8.000	R182,R183,R282,R283,R382,R383,R482,R483
TER-003-23-D	3P TERMINAL	WB03-33CDTP	"+" , Cu-Sn , , , DOWN	1.000	TER3
TER-004-23-D	4P TERMINAL	WB04-34CDTP	"+" , Cu-Sn , , , DOWN	2.000	TER1,TER2
TR-KTB631K	TRANSISTOR	KTB631K		4.000	Q109,Q209,Q309,Q409
TR-KTC3198-B	TRANSISTOR	KTC3198 BULK		4.000	Q107,Q207,Q307,Q407
TR-KTD600K	TRANSISTOR	KTD600K		5.000	Q58,Q108,Q208,Q308,Q408
TR-TIP41C	TRANSISTOR	TIP41C		1.000	Q30
TR-TIP42C	TRANSISTOR	TIP42C		1.000	Q31
DIODE-FMG22R	FAST RECOVERY	FMG22R		2.000	D62,D64
DIODE-FMG22S	FAST RECOVERY	FMG22S		2.000	D61,D63
TR-2SA1694	TRANSISTOR	2SA1694		4.000	Q113,Q213,Q313,Q413
TR-2SC4467	TRANSISTOR	2SC4467		4.000	Q112,Q212,Q312,Q412
<b>&lt; ELECTRONIC - FRONT &gt;</b>					
CCEF-101SL-T	CERAMIC CAPACITOR	100pF/50V 5% SL *5	TAPPING	2.000	C305,C405
CMAI-104J-T	MYLAR CAPACITOR	0.1uF/100V 5%	TAPPING	2.000	C331,C332
CMAI-183J-T	MYLAR CAPACITOR	0.018uF/100V 5%	TAPPING	6.000	C311,C312,C313,C411,C412,C413
CMAI-473J-T	MYLAR CAPACITOR	0.047uF/100V 5%	TAPPING	2.000	C325,C425
CMAI-563J-T	MYLAR CAPACITOR	0.056uF/100V 5%	TAPPING	4.000	C321,C322,C421,C422
CMAI-683J-T	MYLAR CAPACITOR	0.068uF/100V 5%	TAPPING	2.000	C324,C424
JUMP-52-07	JUMP WIRE	52mm *0.7	TAPPING	28.000	
PCB-PFC044-61	FRONT PCB	PFC-044-61 (BLUE)		1.000	
RES1/8-103	RESISTOR	RES 1/8W 10K ohm		11.000	R312,R316,R317,R322,R326,R416,R417,R422,R426,R427,R428
RES1/8-104	RESISTOR	RES 1/8W 100K ohm		2.000	R320,R420
RES1/8-122	RESISTOR	RES 1/8W 1.2K ohm		4.000	R324,R325,R424,R425
RES1/8-154	RESISTOR	RES 1/8W 150K ohm		4.000	R313,R314,R413,R414
RES1/8-163	RESISTOR	RES 1/8W 16K ohm		2.000	R304,R404
RES1/8-222	RESISTOR	RES 1/8W 2.2K ohm		2.000	R306,R406
RES1/8-223	RESISTOR	RES 1/8W 22K ohm		2.000	R302,R402
RES1/8-272	RESISTOR	RES 1/8W 2.7K ohm		2.000	R307,R407
RES1/8-273	RESISTOR	RES 1/8W 27K ohm		2.000	R321,R421
RES1/8-333	RESISTOR	RES 1/8W 33K ohm		2.000	R332,R333
RES1/8-392	RESISTOR	RES 1/8W 3.9K ohm		2.000	R305,R405
RES1/8-393	RESISTOR	RES 1/8W 39K ohm		2.000	R315,R415

# PHANTOM 4000

CODE	ITEM	SPEC	Q'TY	LOCATION
RES1/8-563	RESISTOR	RES 1/8W 56K ohm	2.000	R311,R411
IC-NJM4558D	OP AMP IC	NJM4558D (DIP-8)	7.000	IC20,IC21,IC22,IC23,IC24,IC25,IC26
SWL-2C3P-05	SLIDE SWITCH	SK-23D04-G-G 9mm	2.000	SW1,SW4
TPH04-240-12A	PIN HEADER	TPH04-240-12A	1.000	CON2A
VR09-2016	MAIN VOLUME	15RS 15A 50K ohm 2. RV095 GB Co	1.000	VR3
VR09-2017	MAIN VOLUME	15RS 15C500K ohm 2. RV095 GB Co	1.000	VR11
VR09-2026	MAIN VOLUME	15RS 15C 100Kohm 2.	2.000	VR10,VR12
VR09-4013	MAIN VOLUME	15RS 15C 50K ohm 4. RV095 4GB-1 CO...KNOB	1.000	VR13
<b>&lt; ELECTRONIC - LED &gt;</b>				
PCB-PLC016-01	LED PCB	PLC-016-01 (...)	4.000	
WIRE-CON-002-07	MINI CONNECTOR	CON-002-07 #26-M5264-02 60mm : 3	4.000	
LED-BLUE*3	LED	FG-451013V-FE(BLUE)	4.000	
<b>&lt; MECHANICAL &gt;</b>				
AMAB-0074-00	LOGO STICKER(MAGNAT)	AL0.5t/SILVER PHANTOM-SERIES	1.000	
AMBT-0120-00	HANDLE REFLECTOR	L=300mm,PC(BLUE) PHANTOM4000	2.000	
AMBT-0124-00	STRAW	L=294mm,BLUE PHANTOM4000	2.000	
APBK-0001-BK	T/R SPRING "A"	L=38,t=0.6,BK	6.000	
APBK-0002-BK	T/R SPRING "B"	L=26,t=0.6,BK	3.000	
APBK-0064-00	HANDLE BRACKET	EGI2.0t, SILVER PHANTOM-SERIES	4.000	
APBM-0029-00	RUBBER SPONGE	8x14x5t/.../BK	6.000	for TR(4),THERM(2)
APBM-0057-00	FRONT PCB POST	BSBM/L=24.3mm 4CH	2.000	
APCO-0116-SI	BOTTOM COVER	L=310mm,SILVER PHANTOM4000	1.000	
APHS-0383-00	MAIN HEAT SINK	L=320mm, SILVER.. PHANTOM4000	1.000	
APHS-0386-00	SIDE HEAT SINK	L=50mm, SILVER.. PHANTOM-SERIES	4.000	
APPL-0296-00	FRONT PANEL	EGI1.0t,SILVER/BK PHANTOM4000/4500	1.000	
APPL-0300-00	REAR PANEL	EGI1.0t,SILVER/BK PHANTOM4000	1.000	
XHFM-03+06MN	FLAT MACHINE SCREW	F.H.M 0.3x06 Ni	6.000	for BTM(6)
XHPM-26+04MB	PAN HEAD MACHINE	P.H.M 2.6x04 BK	4.000	for LED PCB(4)
XHPM-26+06MB	PAN MACHINE SCREW	P.H.M 2.6x06 BK	4.000	for FRONT PCB POST(4)
XHPT-03+04CN	PAN HEAD TAPPING	P.H.T 0.3x04 Ni	1.000	for PCB SUPPROT(1)
XHPT-04+08CB	PAN HEAD TAPPING	P.H.T 0.4x08 BK(頭小)	4.000	for ACC'Y
XHWM-03W06MN	WRENCH HEAD MACHINE	W.H.M 0.3x06 Ni(..)	8.000	for PANEL+HANDLE BKT(8)
XHWT-03W06CN	WRENCH HEAD TAPPING	W.H.T 0.3x06 Ni(..)	4.000	for SIDE H/S(4)
XHWT-03W08CN	WRENCH HEAD TAPPING	W.H.T 0.3x08 Ni(..)	18.000	for PANEL(12),RCA(2),TER(3),FUSE(1)
YOVB-0901205	POLY BAG	90x120x0.05t	1.000	for ACC'Y
YOVB-2503505	POLY BAG	250x350x0.05t	1.000	for MANUAL
YOVB-3505005	POLY BAG	350x500x0.05t	1.000	for SET
AMBT-0077-BK	MOUNTING GUIDE-L	AL5.0t,L=25mm ..	2.000	for ACC'Y
AMBT-0078-BK	MOUNTING GUIDE-R	AL5.0t,L=25mm ..	2.000	for ACC'Y
APBM-0091-00	S/W FELT	PVC 0.3t / BK LT-SERIES	3.000	
QPCB-PHAN4000	CARTON BOX	2 SETS/CTN	0.500	



## PHANTOM 4000

CODE	ITEM	SPEC	Q'TY	LOCATION
QPCP-PHAN4000	CARTON PAD	2 PCS/CTN	1.000	
QPCB-PHAN4000	GIFT BOX		1.000	
QPIM-PHAN 4CH	MANUAL		1.000	
QPSL-00000002	SERIAL LABEL	MADE IN CHINA(有) (....)	4.000	FOR MANUAL,SET,G/BOX,C/BOX
QPSP-PHAN4000	SET PAD	PAPER PAD	1.000	