

S/M No. : OSPC740001

Service Manual

Portable DVD Player

Model: DPC-7400 Series



Caution

: In this Manual, some parts can be changed for improving, their performance without notice in the parts list.

DAEWOO
ELECTRONICS

May. 2005

DAEWOO

【Revision Record】

Date	Rev No	Section	Description
17/ Oct./ 2005	0.1	New edition	

- Design and specifications are subject to change without notice.
- All trademarks used in the specifications are the property of their respective owners.

1. General Descriptions.....	1
1.1. Model Features.....	1
1.2. Information.....	2
2. Electrical Characteristics.....	3
2.1. Optical Characteristics.....	3
2.2. Electrical Characteristics.....	3
2.3. System Block Diagram.....	4
3. Power.....	11
3.1. Power Supply.....	11
3.2. Rechargeable Battery.....	11
4. Dimension & Physical Characteristics.....	13
4.1. Outline Dimension.....	13
4.2. Physical Characteristics.....	13
4.3. Exploded View.....	14
5. Regulatory Standards.....	15
5.1. Safety.....	15
5.2. EMI.....	15
5.3. Ergonomics.....	15
6. Service Tools and Equipment.....	16
6.1. Service Tools and Equipment.....	16
6.2. Storing and Handling Test Discs.....	16
6.3. Notes.....	17
7. Spare Parts.....	19
7.1. key Parts List.....	19
8. Trouble shooting.....	20
8.1. Error Code Table.....	20
8.2. Debug & Trouble Shooting.....	21

1 General Descriptions

1.1 Model Features

- Video: DVD Playback, MPEG4(option) ,DivX(DivX Model),Kodak Picture CD compatible & JPEG readable
- Audio: CD, CD-R, CD-RW, MP3, WMA Playback
- Firmware Upgradable
- Dolby Digital Output
- 7" active-matrix TFT screen, 16:9 wide aspect ratio
- Composite Video Output
- Ultra dimension & light weight: 200mm(L) x 155mm(W) x 38mm(H) / 900g (around)
- Slim size wireless remote control
- Rechargeable battery pack
- 12-volt car cigarette lighter cable
- Universal AC/DC power adapter
- Audio/video cable for TV connection
- Built-in stereo speakers
- Two Stereo headphone jack
- Parental Lock
- Anti Shock Protection



1.2 Information

Disk Format	DVD, VCD, CD, MP3, CD-R, CD-RW, MPEG4 (OPTION), JPEG, Kodak Picture CD, DivX(DivX Model), WMA
Video System	NTSC / PAL/Auto
Video Decompression	MPEG-2 (ISO/IEC-13818), MPEG-1
Video Output	800~1200mVpp/75 ohm
Audio Characteristic	2-Channel Analog
Analog Output	1.0~2.0Vrms/10K ohm
Frequency Response	DVD: 48kHz Sampling: 20Hz-20kHz CD: 20Hz-20kHz
S/N Ratio	<= -65dB
Dynamic Range	<= -85dB
Audio Output Noise & Distortion	Less than <= 0.01%
Digital Output	SPDIF
Headphone Jack	32ohm (30Mw) > 8ohm
LCD Display	7" active-matrix TFT type
Audio / Video Section	Audio input/output x1 Video input/output x1 S-Video / Coaxial output x1
Audio Section	Digital Output: Coaxial x1
Headphone Jack	Headphone Jack x1
Line Voltage	AC 100~240 VAC \pm 10%(50/60Hz), (Adapter)
Power Consumption	12W (DC 12V, 1.0A)
Remote Control	DC 3V Infra-red
Dimensions	200mm(L) x 155mm(W) x 38mm(H)
Weight	900 g (around)
Accessories	Slim Size Remote Controller with 3V Battery 12-volt Car Cigarette Lighter Cable Universal AC/DC Power Adapter Audio Cable / Video Cable Ni-MH Rechargeable Battery Pack S-video / Coaxial cable

2 Electrical Characteristics

2.1 Optical Characteristics

Parameter	Specifications	Unit
Screen Size	7.0 (16:9 diagonal)	inch
Display Format	1400 (H) × 234 (V)	dot
Active Area	154.08 (H) × 86.08 (V)	mm
Dot Pitch	0.107 (H) × 0.370 (V)	mm
Pixel Configuration	Stripe	
Outline Dimension	166.0 (W) × 100.0 (H) × 7.2 (D)(typ.)	mm
Surface Treatment	Anti-Glare and Hard Coating	
Weight	180 ± 10	g

2.2 Electrical Characteristics

- DVD/ SVCD/ VCD/ CD system decoding, packeted element streams and audio, video element streams.
- Fully digital servo processing (focusing, tracking, sledge and spindle servo control)
- Fully digital calibration (focusing/ tracking offset and balance)
- Digital phase lock loop with phase equalizer
- Support Audio/ Video/ Photograph decoding and programming
- Programmable Y/C delay relationship
- Embedded micro-controller, up to 50MHz operating frequency
- 1.8V and 3.3V dual power supply, 208 pin PQFP

2.3 System Block Diagram

2.3.1. The System Block Diagram & the Block's Function Description

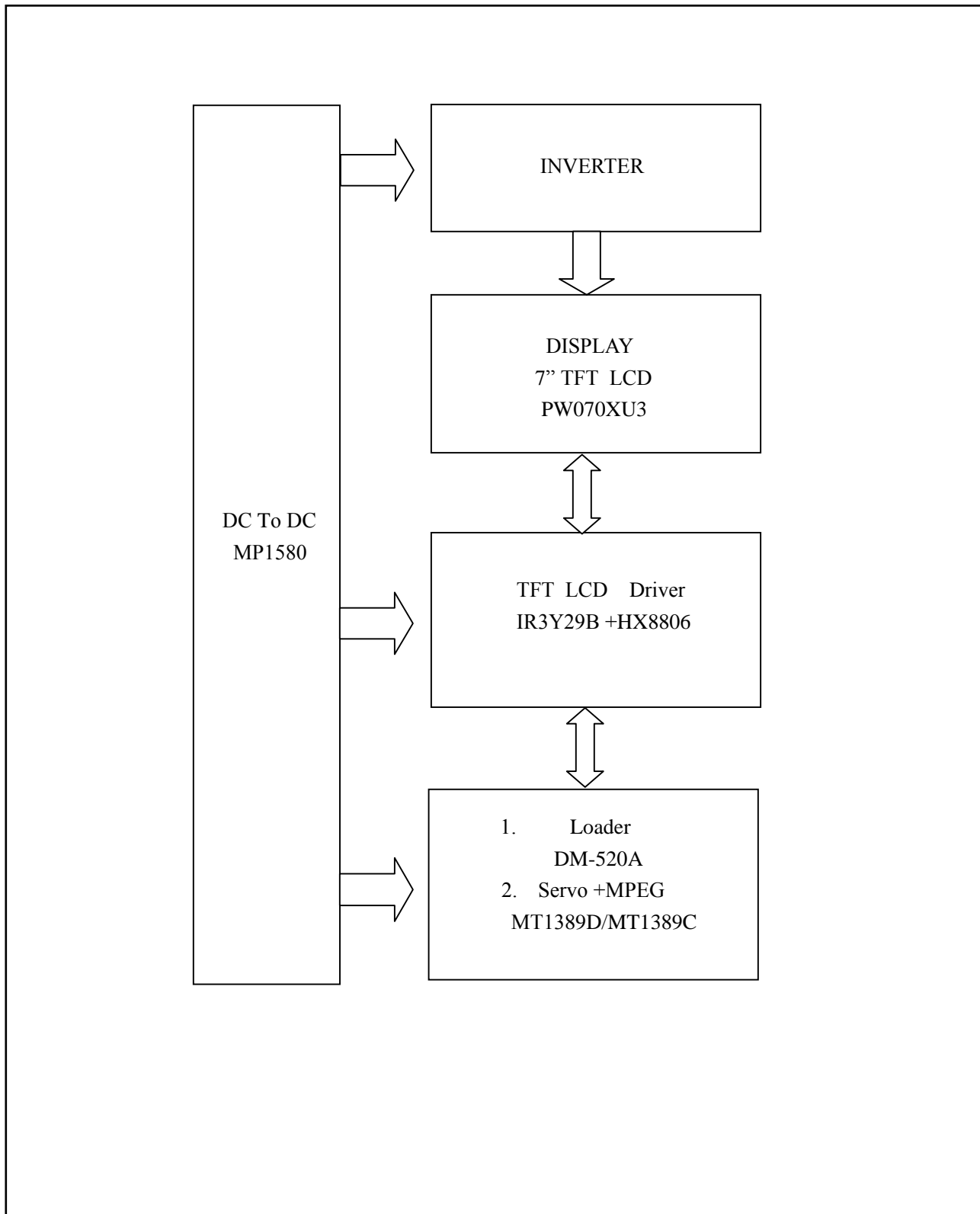

2.3.2 Schematic Circuit Diagram (1) POWER_MPS

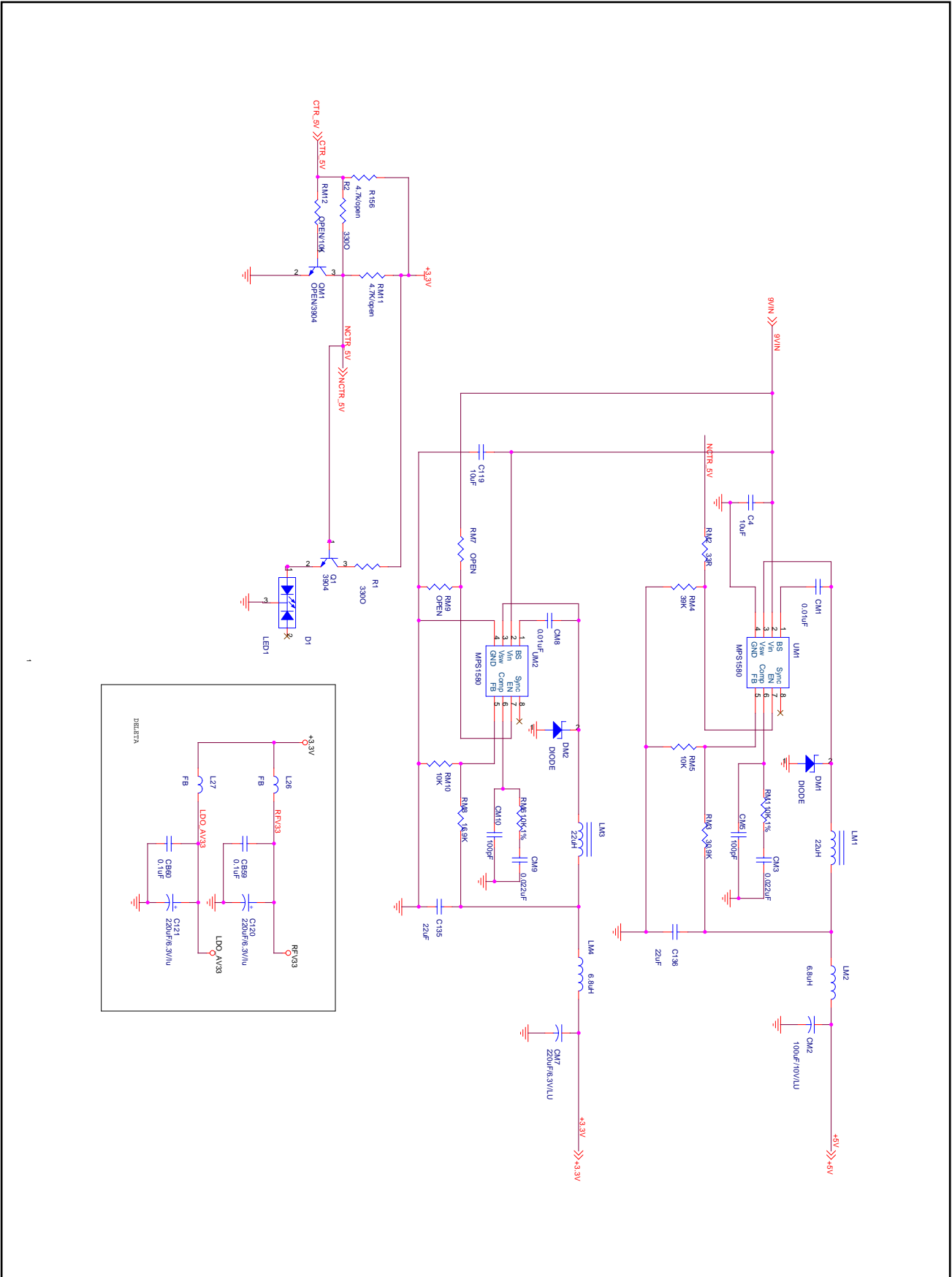

(2) POWER FOR TFT

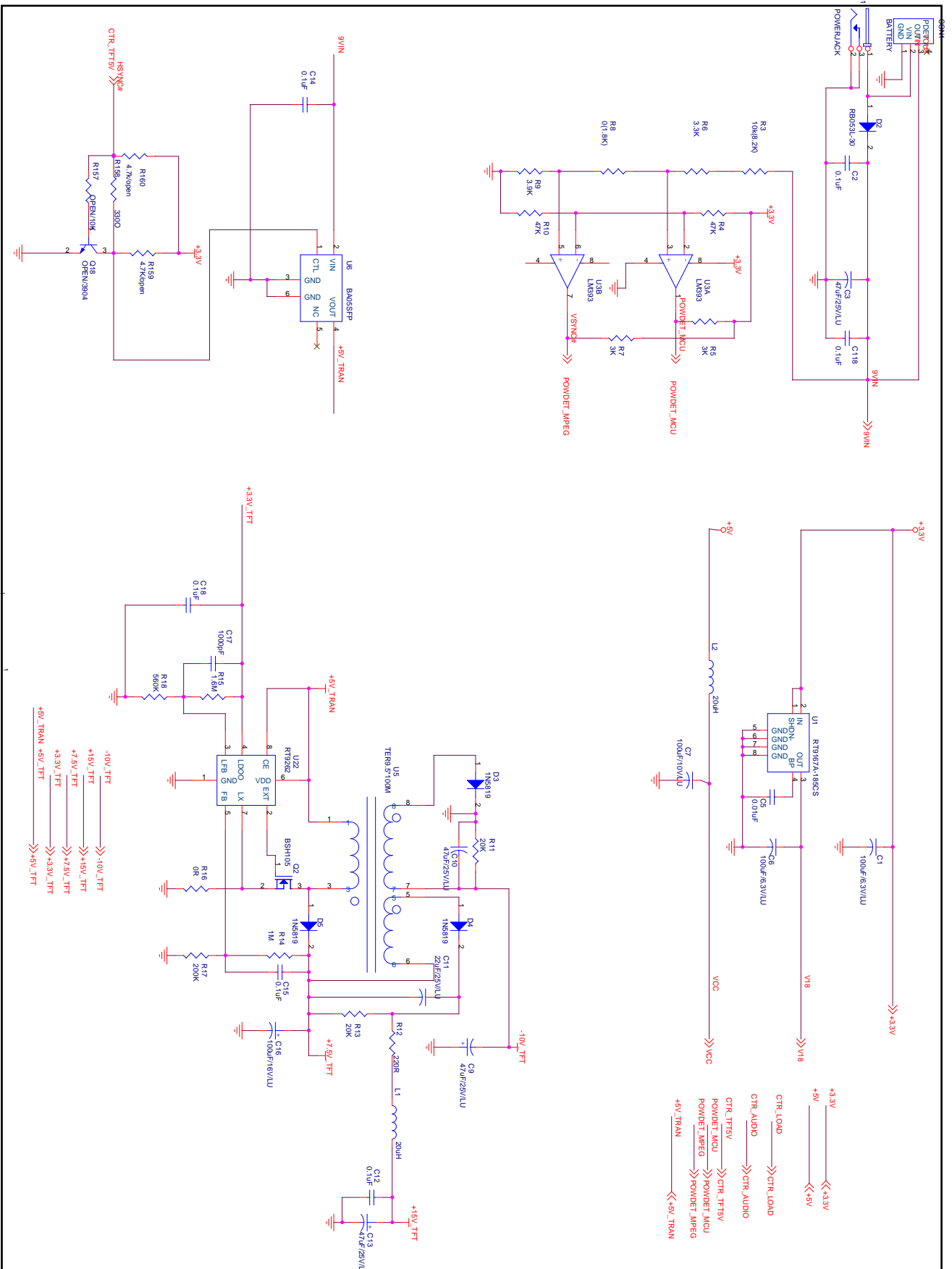

(3) SERVO&MPEG

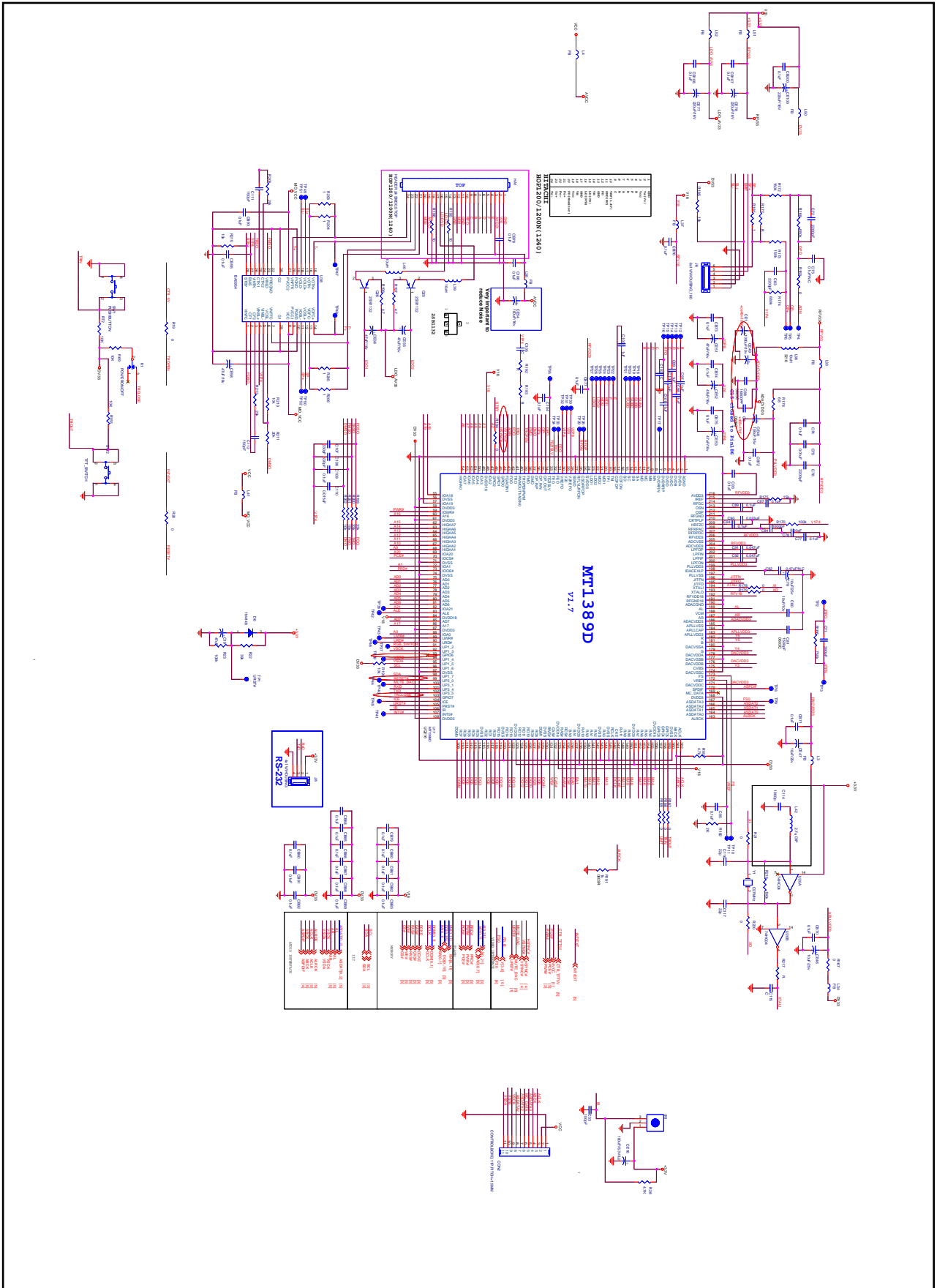

(4) SDRAM&FLASH&EEPROM

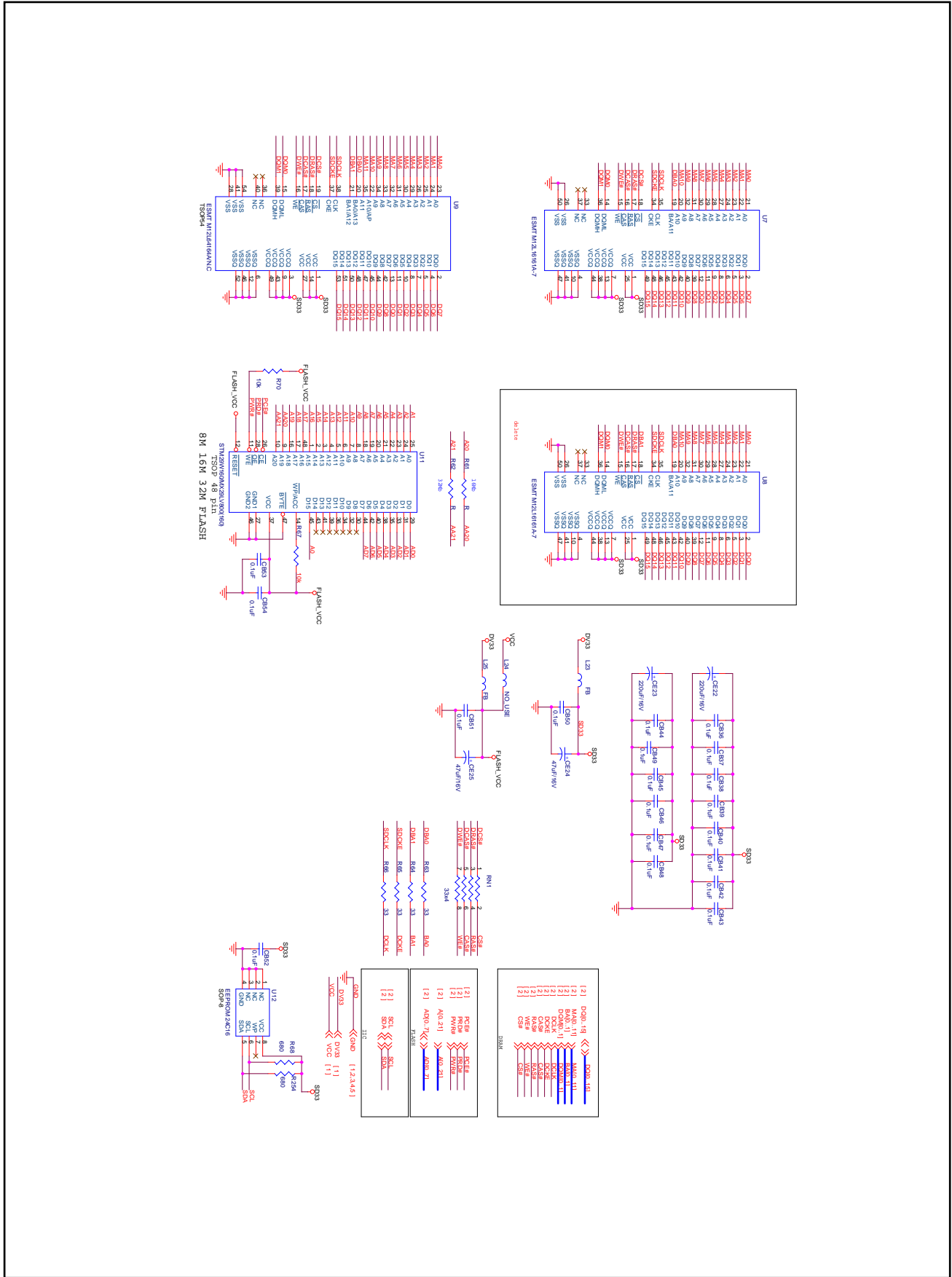

(5) VIDEO OUTPUT

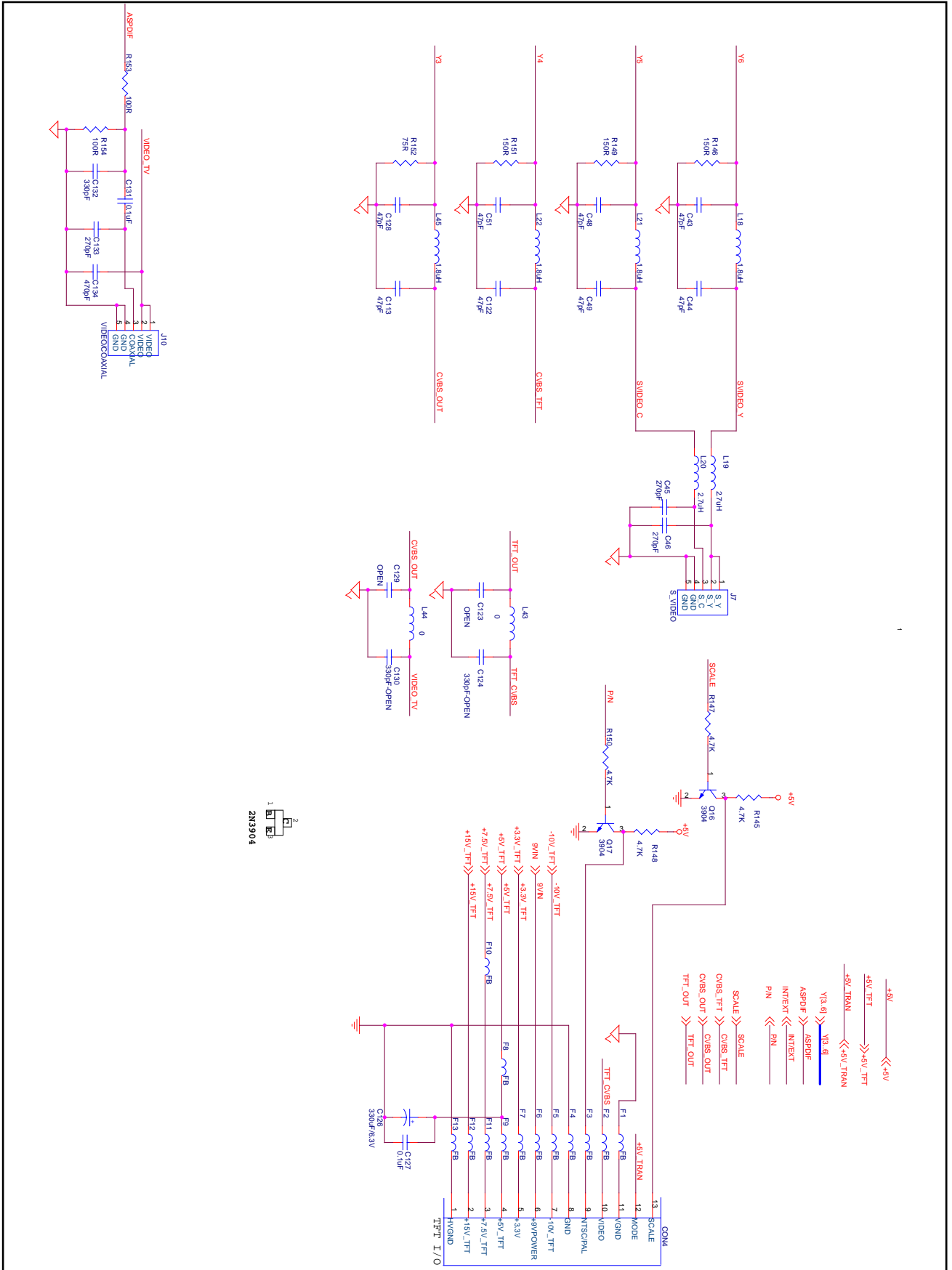

(6) AUDIO OUTPUT

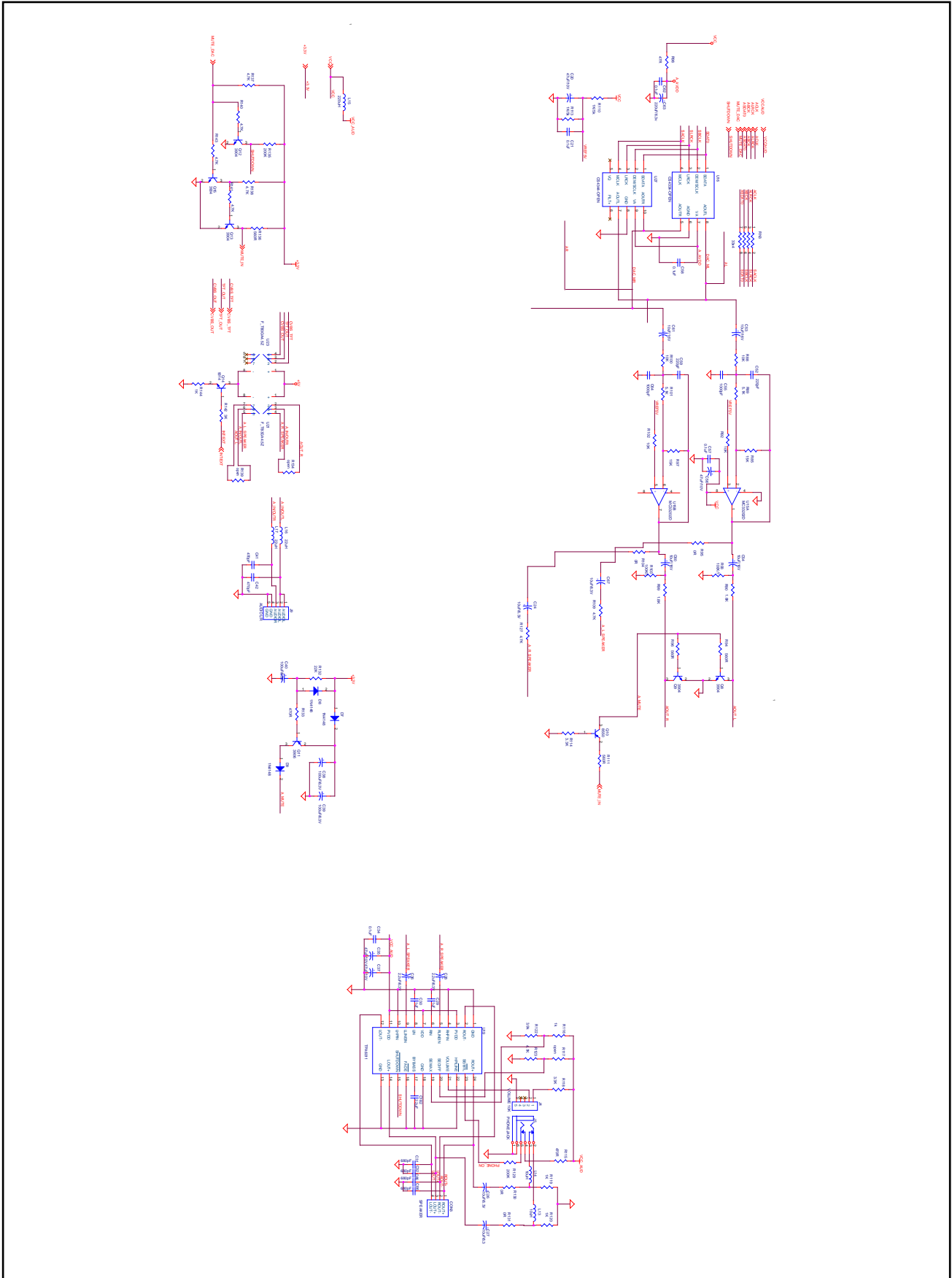

3 Power

3.1 Power Supply

- Input voltage:
 - Normal voltage: 100 to 240 Vac.
 - Variation range: 90 to 264 Vac.
- Input frequency:
 - Normal frequency: 50 to 60 Hz.
 - Variation range: 47 to 63 Hz.
- Input current: 0.6 arms max. at any input voltage and max. DC output rated load.
- Inrush current: 70 amps max. cold start at 240 Vaz. Input, with rated load and 25°C ambient.
- AC leakage current: 0.25 mA max. at 240 Vac. Input.

3.2 Rechargeable Battery

- Output Voltage : 8.4~6.0V
- Cut-off Voltage : 5.7~6.0V
- Charge voltage : The battery pack should be charged when the input voltage is from 11V to 15V
- Charger : a.) Hiteker DC12V/2.7A adaptor.
 - b.) Hiteker DC12V/2.7A adaptor and Portable DVD
- LED is in red color when the battery pack is in charging; and turns into green color when batter pack is full.
- If the battery pack is in Full status, no matter use adaptor charge directly or link DVD to charge again, the LED must be turn into green color in 15 min.
- The cycle life of battery pack has more than 300 cycles.
- Charge: The battery pack must be able to charge when used the Hiteker DC12V/2.7A adaptor or Hiteker DC12V/2.7A adaptor and portable DVD (power off status).
- Discharge: Using the battery pack as the power source for portable DVD that in DVD disc playing mode, the discharging time must be exceed 2.5hrs.

3.2.1 Electrical Protection

- The battery pack shall be capable of withstanding a continuous short circuit output without damage.

- The battery pack shall return to normal operation only after the fault has been removed.
- A thermal fuse must be added on the surface of cell body to protect the battery pack.
- A polyswitch must be add to protect the battery pack.
- Charge & Play Time of Battery Pack

	Charge Time (hr)	DVD Title Play Time (hr)	Styling
Ni-MH 2400mAh (6S1P)	4~5	2.5	 <p>For DPC-7400 Series</p>

4 Dimension & Physical Characteristics

4.1 Outline Dimension

- 200mm(L) x 155mm(W) x 38mm(H)



4.2 Physical Characteristics

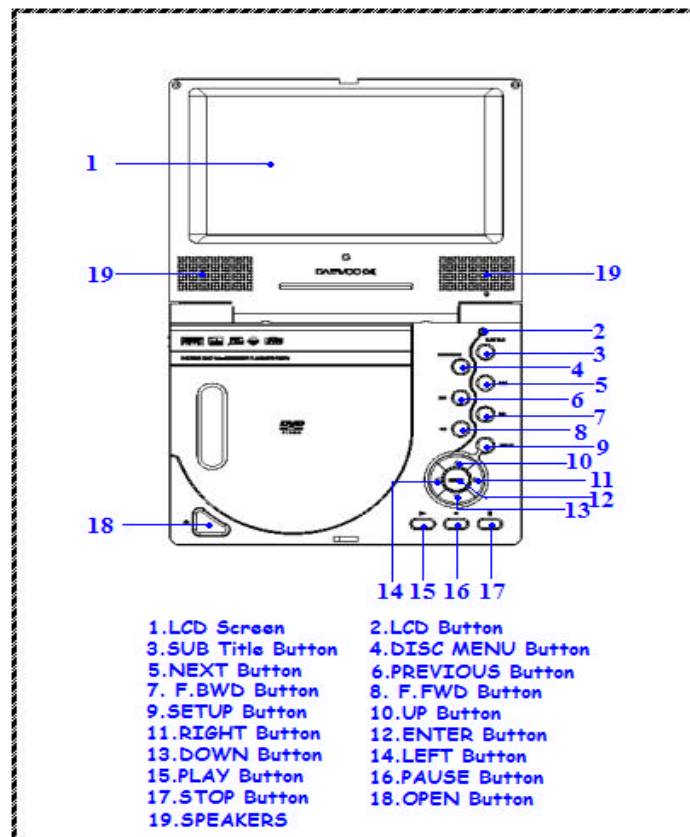

4.3 Exploded View

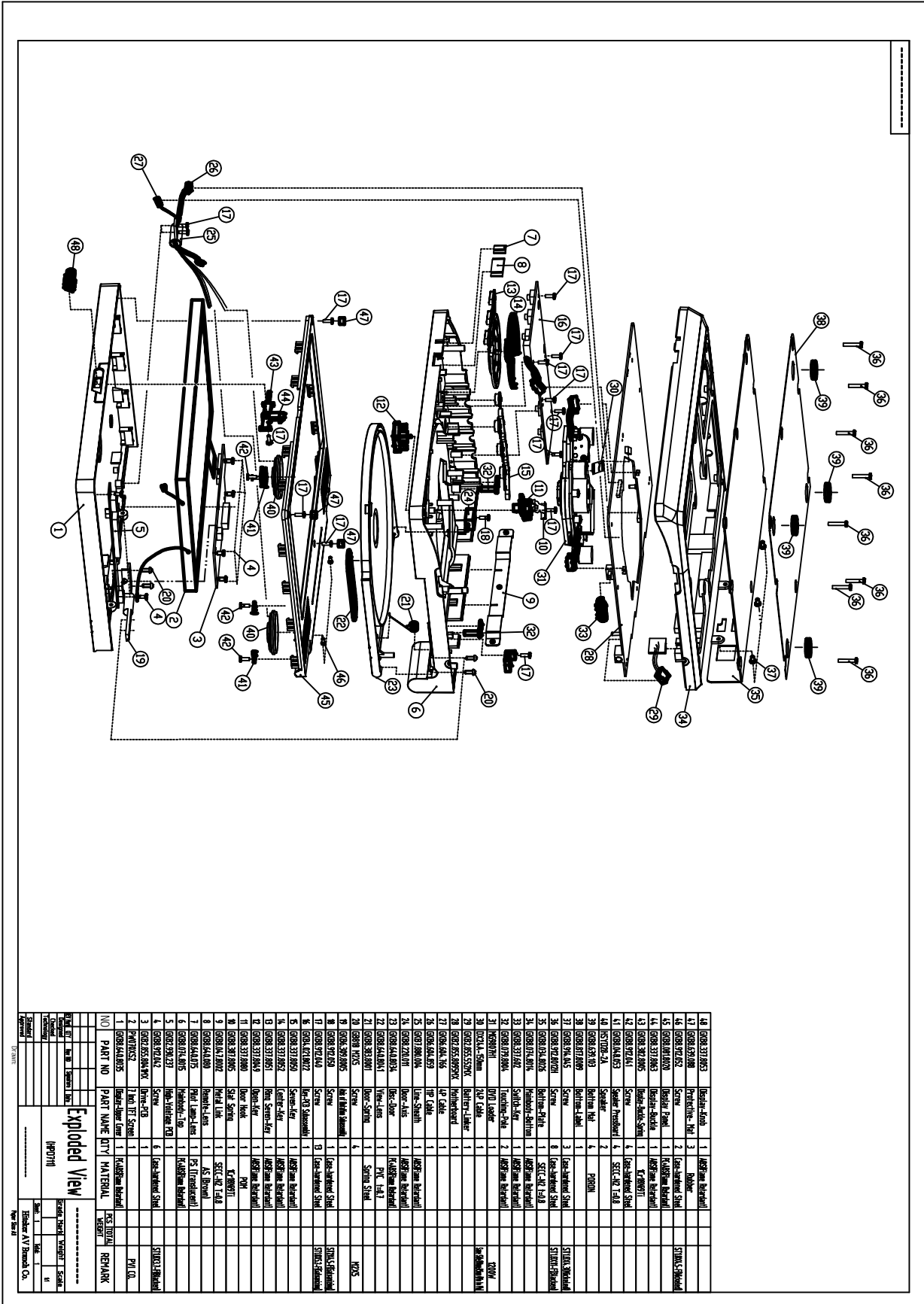

5 *Regulatory Standards*

5.1 Safety

- UL
- FDA
- LVD

5.2 EMI

- CE
- FCC

5.3 Ergonomics

- Dolby

6 Service Tools and Equipment

6.1 Service Tools and Equipment Table

Application	Name
General	DVD Testing Disc
	General Tools (screwdriver etc.)
Confirm	CD Testing Disc
	VCD Testing Disc
Adjust	Oscilloscope
	Probes
	AV Cables
	TV Monitor
Grounding for electrostatic breakdown	Searing-iron
	Antistatic wrist strap
	Conductive material (steel sheet)

6.2 Storing and Handling Test Discs

It is important for a DVD testing disc keeping its surface precise. Please care for storing and using it.

1. Do not place the disc on worktable directly after using.
2. Do not store discs in places subject to direct sunlight or near heat sources.

3. Do not place the disc on a glass surface. It may damage the disc. If this happened, please use a new testing disc adjust DVD player precision.

6.3 Notes

PLEASE READ ALL NOTES GIVEN IN THIS MANUAL.

■ Locate

- Place the unit on a firm, flat surface.
- Do not place in a high temperature (upwards of 40°C) or high wet (upwards of 80 percent) area.
- Do not place in an area with a lot of dust.
- Keep away from direct sunlight & domestic heating equipment.

■ Do not fall any objects into the unit.

- Care should be taken so that liquids are not spilled into the unit openings. Such situations could result in fire or electrical shock.
- Keep the DVD video player away from any magnetic articles such as speaker etc.

■ Superposition

- Please place the DVD player horizontally. Do not place a heavy object (amplifier, receiver) on it. The object may fall, causing serious personal injury

or death.

- This unit should be situated away from heat source, such as amplifiers, radiators, stoves or any other units producing heat.

■ **Condensation**

Lens could be moistening in these cases.

- Turn on heater shortly,
- In a very wet room,
- Move the player from a cold environment to a heat environment quickly.

Being moisture inside the play could operate normally. Please turn on power and wait about an hour for drying the moisture.

7 Spare Parts

7.1 Key Parts List

<i>Location</i>	<i>Part NO</i>	<i>Part Name</i>	<i>Description</i>	<i>Maker</i>	<i>Remark</i>
	GKB2.855.8105MX	Main Board	MEPG Board	Hiteker	W/O DivX
	GKB2.855.8138MX		MEPG Board(With DivX)	Hiteker	With DivX
U17	MT1389QE_D	MPEG IC	MTK1389D	MTK	W/O DivX
U11	ICMT1389DE-C		MTK1389C	MTK	With DivX
U11	AT49LV4096AT-70TC	FLASH Memory IC	4M Memory	ATMEL	W/O DivX
U14	ICMX26LV800BTC-70		8M Memory	FUJITSU	With DivX
U7	IC42S16100-7T	SDRAM IC	SDRAM IC	ISSI	W/O DivX
U13	IS42S16400-7T		SDRAM IC	ISSI	With DivX
U38	ICBA5954FP	MOTOR DRIVE IC	DRIVE IC	ROHM	W/O DivX
U12	ICBA5954FP		DRIVE IC	ROHM	With DivX
U12	IC24C02	EEPROM IC	EEPROM IC	ATMEL	W/O DivX
U15	IC24C02		EEPROM IC	ATMEL	With DivX
UM1/2	MP1580	Power Trans IC	DC TO DC	MPS	W/O DivX
U1/2	MP1580		DC TO DC	MPS	With DivX
U19	TPA6011	AUDIO Trans IC	AUDIO Amplifier	TI	W/O DivX
U20	TPA6011		AUDIO Amplifier	TI	With DivX
	GKB4.021.8027MX	Key PCB	Function Key Part	Hiteker	For All
	GKB2.930.8026MX	High Voltage PCB	High Voltage PCB	TOP-STAR	For All
	GKB2.855.8042MX	Drive PCB	TFT LCD Driver	Hiteker	For All
U201	HX8806	TCON IC	TCON IC	HIMAX	For All
U1	IR3Y29B	VIDEO Decode IC	VIDEO Decode IC	SHARP	For All
	DM-520A	Loader	DVD Player	Foryou	For All
	HOP-1200W	Pick up	Pick up	HITACH	For All
	CCM03-030R1-49	Spindle Motor	Spindle Motor	Moretech	For All
	WFF-030PB-08315	Sled Motor	Sled Motor	WeiZhen	For All
	PW070XU3	TFT Screen	TFT screen	PVI	For All
	GKB4.819.8045MX	Rechargeable Battery	<i>Ni-MH2400mAh</i>	Rebenergy	For All
	GKB2.930.8015	AC/DC Adapter	DC 12V 2.7A	SiDa	For All
	GKB2.018.8072WX	Remote Control	Remote Control	FeiDa	For All

8 Trouble Shooting

8.1 Error Code Table

CODE	Descriptions of Error	Note
Power Test		
T01	No power no action	
T02	Power Led indicator is not on or insufficient brightness	
T03	Loading time too long	
T04	Remote control bad sensing or not functional	
T05	System stays in the Run In condition after power on, can't be tested	
T06	System down at power on	
T07	System down during playing	
T08	Power on unstable	
T09	Abnormal sound in the system	
Disc Drive Test		
T11	Can't read the disc (No Disc)	
T12	Disc drive no action or locked	
T13	Disc drive scratches the disc	
T14	Some discs can't be played (can't play CD or VCD or DVD)	
T15	Head does not work	
T16	Spindle does not work	
Video Test		
T21	No video / abnormal (Please indicate the abnormal condition)	
T22	Video: no video / abnormal (Please indicate the abnormal condition)	
T23	S-Video No video / abnormal or black & white (Please indicate the abnormal condition)	
T24	VCD picture abnormal (Please indicate the abnormal condition)	
T25	DVD picture abnormal (Please indicate the abnormal condition)	
T26	Picture subtitle display abnormal or no display	
T27	Setting menu picture abnormal (Please indicate the abnormal condition)	
Audio Test		
T31	Audio / left sound channel (AOL) does not have waveform (sound) or waveform (sound) abnormal	
T32	Audio / right sound channel (AOR) does not have waveform (sound) or waveform (sound) abnormal	

T33	MP3 abnormal sound	
T34	Audio no waveform (sound) or waveform (sound) abnormal	
Earphone Test		
T41	Earphone no sound or the sound has pause, abnormal sound, noise, echo	
T42	Earphone (right) no sound or the sound has pause, abnormal sound, noise	
T43	Earphone (left) no sound or the sound has pause, abnormal sound, noise	
Function Key Test		
T51	Video can't be still or stop	
T52	Can't execute fast forward or rewind	
T53	Panel button	
System Setting Test		
T61	Can't enter the system setting	
T62	The system can not be played or it is down after the system is set	
TFT Test		
T71	TFT image and color error	
T72	TFT image is black and white	
T73	TFT image shakes and is distorted	
T74	TFT PAL color strip	
T75	TFT ripple	

6.2 Debug & Trouble Shooting

- Please check the PCB for any missing components and bad soldering
- *T01 · No Power*
 - ✓ Main Board
 - A. Check for components on the Main Board to see if there are any short circuits.
 - B. Check for the power adapter to see if the 12v power is abnormal.
 - C. Check for components C6,C7,CE100,C3 on the Main Board to see if there are any short circuits.
 - D. Check for component CN1 on the Main Board to see if the switch have function.
 - E. If none of the above actions is effective, please change Main Board.
- *T02 · Power LED indicator not on or insufficient brightness*
 - ✓ Main Board
 - A. Open the cover of the portable DVD-player to inspect if LED functions normally.
 - B. Measure the base electrode of Q1 to see if the voltage is high_and the emitter of Q1 must be high voltage. Q1 is a NPN 3904 type transistor. If it is abnormal ,

Please replace with a good one.

- D. Disassemble F/W, replace with a good one or re-plug it to see if the LED lights up when Power ON.
- E. If the above actions are not working, replace the Main Board.

- *T03 · Loading time too long*

- ✓ Main Board

- A. Check the flat cable to see if it is adhibited to the right place.
 - B. Remove the cover to see if the resistors or resistor-array adjacent to U38 and or U17, to see if there is any cold soldering, hollow soldering, misplaced soldering, or wrong part.
 - C. If the above actions are not working, replace the Main Board.

- *T04 · Remote control bad sensing or sensing not functional*

- ✓ Remote control

- A. If the main body of the system works normally, then making sure that the battery of the Remote control has sufficient power, if it is not, replace the battery.

- ✓ Main Board

- A. Remove the top cover and the panel. Check to see if IR1 has short circuit, broken circuit, hollow soldering, or other problems. Also check if the pins 1 of IR1 have power.
 - B. If the above actions are not working, replace the Main Board.

- *T05 · Stay in the Run In condition after power on, can't be tested*

- ✓ Main Board

- A. The same refer to T03.
 - B. If the above actions are not working, replace the Main Board.

- *T06 · System down at power on*

- ✓ Main Board

- A. Remove the top cover, check all flat cables in the system to see if they are correctly plugged to the fixed positions, or re-plug them.
 - B. Check the pin 1 of U3 to see if it is low voltage. If not , disassemble R5 or pull it to low voltage with a lead.
 - C. If the above actions are not working, replace the Main Board.

- *T07 · System down during play*

- ✓ Main Board

- A. Exclude the condition of using battery. (The system will down when the voltage is too low.)
 - B. Disassemble U17 F/W, replace with a good one or re-plug it to see if the symptom will disappear.

- C. Remove the top cover, check all flat cables in the system to see if they are correctly plugged to the fixed positions, or re-plug them.
 - D. Check the capacitors C19 and the diode D6 to see if the reset circuit works normally.
 - E. If the above actions are not working, replace the Main Board.
- ✓ DVD ROM
 - A. Check the loader to see if it is not stable (any condition that some of the discs can't be played). If so, replace the loader.
- ✓ DVD DISC
 - A. Check the Test Disc to see if there is any serious scratch or ring shape, circular shape scratches, if so, replace the Test Disc and test again.
- *T08 · Power on unstable*
 - ✓ Main Board
 - A. Remove the top cover, check all flat cables in the system to see if they are correctly plugged to the fixed positions, or re-plug them.
 - B. Check the LDO Q3 to see if it works normally with a 1.8V output voltage.
 - C. Check the reset circuit refer to the title T07-D.
 - D. If the above actions are not working, replace the Main Board.
- *T09 · Abnormal sound in the machine base (Power on abnormal sound)*
 - ✓ DVD ROM
 - A. Check the loader to see if it is the source of the abnormal sound. If so, replace the loader.
 - B. If the abnormal sound comes from the audio speakers, check the audion PNP3906 type Q16 and NPN 3904 type Q8/9/10/12/13/15 to confirm the mute circuit works normally. If not ,change the audion.
- *T11 · Disc drive can't read (NO DISC)*
 - ✓ Main Board
 - A. Remove the top cover, check the 28-pin flat cable in the system to see if they are correctly plugged to the fixed positions, or re-plug them.
 - B. Check the resistors or resistor-array adjacent to U38 and U17 to see if there is any hollow soldering or cold soldering.
 - C. If the above actions are not working, replace the Main Board. If it is still not working, replace the loader.
 - ✓ DVD ROM
 - A. Check the loader to see if it can't read. If so, replace the loader.
- *T12 · Disc drive no action or locked*
 - ✓ Main Board
 - A. Remove the cover. Check to see if it is caused by mis-assembly.
 - B. Check the resistors or capacitors adjacent to U38 to see if there is any hollow soldering or cold soldering.
 - C. If the above actions are not working, replace the loader. If it is still not working,

replace the main board.

- *T13 · Disc drive scratches disc*

- ✓ Main Board

- A. Check the resistors or capacitors adjacent to IC(U17) to see if there is any hollow soldering, cold soldering, wrong part, or misplaced soldering.
 - B. If the above actions are not working, replace the loader. If it is still not working, replace the main board.

- ✓ DVD ROM

- A. Check the loader to see if it is the cause of disc scratching. If so, replace the loader.

- *T14 · Not every disc can be played*

- ✓ Main Board

- A. Check the resistors or capacitors adjacent to IC(U17) to see if there is any hollow soldering, cold soldering, wrong part, or misplaced soldering.
 - B. If the above actions are not working, replace the loader. If it is still not working, replace the main board.

- *T15 · Head does not work*

- ✓ Main Board

- A. Remove the top cover, check the 28-pin flat cable and the 2-pin cable in the system to see if they are correctly plugged to the fixed positions, or re-plug them.
 - B. Check the resistors or capacitors adjacent to IC(U17) to see if there is any hollow soldering, cold soldering, wrong part, or misplaced soldering.
 - C. If the above actions are not working, replace the loader. If it is still not working, replace the main board.

- *T16 · Spindle does not work.*

- ✓ Main Board

- A. Remove the top cover, check the 4-pin flat cable in the system to see if they are correctly plugged to the fixed positions, or re-plug them.
 - B. Check the resistors or capacitors adjacent to IC(U17) to see if there is any hollow soldering, cold soldering, wrong part, or misplaced soldering.
 - C. If the above actions are not working, replace the loader. If it is still not working, replace the main board.

- *T21 · no video / abnormal*

- ✓ Main Board

- A. Remove the top cover, check all flat cables in the system to see if they are

correctly plugged to the fixed positions, or re-plug them.

- B. Use oscilloscope to measure if Y1 generates 27MHz. If it does not generate said frequency, and the problems such as cold or hollow soldering have been ruled out, it maybe Y1 work abnormally . Replace Y1 with a 27MHz fundamental frequency oscillator.
 - C. Check if U17(F/W) IC has any problem.
 - D. Check if switch for TFT on/off is normal; replace a new one if necessary.
 - E. If the above actions are not working, replace the Main Board.
- ✓ Driver Board
- A. Check VR6,VR4,VR1,VR7,VR5 is using the correct component. Also check if it's damaged.
 - B. Adjust VR4,VR6,VR1,VR7,VR5 to the appropriate value.
- ✓ DVD ROM (less likely to happen)
- A. If it is useless to change the main board, then replace the loader.
- *T22 · Video no video / abnormal*
 - ✓ Main Board
 - A. Remove the cover. Check the main board to see if there is any cold or hollow soldering and rule out the problem.
 - B. Remove the top cover, check all flat cables in the system to see if they are correctly plugged to the fixed positions, or re-plug them.
 - C. Check RLC following CVBS to see if there is any wrong parts, cold and hollow soldering, short circuit, broken circuit, broken parts and rule out the problem.
 - D. If the above actions do not work, then check U17Pin175 and Pin182 to see if there is CVBS signals.
 - E. If the above actions are not working, replace the Main Board.
 - *T23 · S-Video no video / abnormal or black & white*
 - ✓ Main Board
 - A. Remove the cover. Check the main board to see if there is any cold or hollow soldering and rule out the problem.
 - B. Remove the top cover, check all flat cables in the system to see if they are correctly plugged to the fixed positions, or re-plug them.
 - C. Check RLC following Y and C to see if there is any wrong parts, cold and hollow soldering, short circuit, broken circuit, broken parts and rule out the problem.

- D. If the above actions do not work, then check U17 Pin179 and Pin181 to see if there is Y and C signals.
 - E. If the above actions are not working, replace the Main Board.

- *T24 · VCD abnormal picture*
 - ✓ Main Board
 - A. Check main board to see if there is any cold or hollow soldering and short circuit problem and rule out the problem.
 - B. Check the resistors or capacitors components or those adjacent to IC to see if there is any hollow soldering, cold soldering, wrong part, or misplaced soldering.
 - C. If the above actions are not working, replace the Main Board.
 - ✓ DVD ROM
 - A. If the abnormal picture is the problem of pause or skipping tracks, then making sure if the disc has any scratches or dirt, if no such problems then replace the loader.

- *T25 · DVD abnormal picture*
 - ✓ Main Board
 - A. Check U17 to see if there is any cold or hollow soldering and short circuit problem and rule out the problem.
 - B. Check the resistors or capacitors components or those adjacent to IC to see if there is any hollow soldering, cold soldering, wrong part, or misplaced soldering.
 - C. If the above actions are not working, replace the Main Board.
 - ✓ DVD ROM
 - A. If the abnormal picture is the problem of pause or skipping tracks, then making sure if the disc has any scratches or dirt, if no such problems then replace the loader.

- *T26 · Picture subtitle abnormal display or no display*
 - ✓ Main Board
 - A. Remove the top cover and dis-assemble F/W (U17). Replace it with a good F/W or re-plug it, then check if the action is normal. Otherwise replace the F/W.
 - B. Check U17 to see if there is any cold or hollow soldering and short circuit problem and rule out the problem.
 - C. If the above actions are not working, replace the Main Board.

- *T27 · Setting menu abnormal picture*
 - ✓ Main Board
 - A. Check U17 to see if there is any cold or hollow soldering and rule out the problem.

- B. Remove and dis-assemble U7 with a 16Mbit SDRAM.
 - C. If the above actions are not working, replace the Main Board.
- *T31 · Audio /left channel (AOL) no sound or abnormal sound*
 - ✓ Main Board
 - A. Remove the cover. Check U15 on the Main board to see if there is any cold soldering, hollow soldering, or damage. Rule out the problem.
 - B. Check all parts following AOL to see if there is any cold or hollow soldering, short circuit, broken circuit, parts missing, wrong parts and rule out the problem.
 - C. If the above actions are not working, replace the Main Board.
- *T32 · Audio /right channel (AOR) no sound or abnormal sound*
 - ✓ Main Board
 - A. Remove the cover. Check U15 on the Main board to see if there is any cold soldering, hollow soldering, or damage. Rule out the problem.
 - B. Check all parts following AOR to see if there is any cold or hollow soldering, short circuit, broken circuit, parts missing, wrong parts and rule out the problem.
 - C. If the above actions are not working, replace the Main Board.
- *T33 · MP3 abnormal sound*
 - ✓ Main Board
 - A. Remove the top cover, check all flat cables in the system to see if they are correctly plugged to the fixed positions, or re-plug them.
 - B. Check the resistors or capacitors components on the main board, or those adjacent to IC to see if there is any hollow soldering or cold soldering.
 - C. If the above actions are not working, replace the main board. If it is still not working, replace the loader.
- *T34 · Audio no waveform (sound) or waveform (sound) abnormal*
 - ✓ Main Board
 - A. Remove the cover. Check U15 on the main board to see if there is any cold or hollow soldering and rule out the problem.
 - B. Check all parts following AOL and AOR to see if there is any cold or hollow soldering, short circuit, broken circuit, parts missing, or wrong parts. Rule out the problem.
 - C. If the above actions are not working, replace the Main Board.
- *T41 · Earphone Audio no waveform (sound) or waveform (sound) abnormal*
 - ✓ Main Board
 - A. Remove the top cover, check all flat cables in the system to see if they are correctly plugged to the fixed positions, or re-plug them.

- B. Check U19,U15 and J4,CON3 to see if there is any cold or hollow soldering and rule out the problem.
 - C. If the above action does not work after the inspection, replace the main board.
- *T42 · Earphone Audio right no waveform (sound) or waveform (sound) abnormal*
 - ✓ Main Board
 - A. Check U19,U15 and J4,CON3 to see if there is any cold or hollow soldering and rule out the problem. Especially check for C24,C26,C28.
 - B. If the above action does not work after the inspection, replace the main board.
- *T43 · Earphone Audio left no waveform (sound) or waveform (sound) abnormal*
 - ✓ Main Board
 - A. Check U19,U15 and J4,CON3 to see if there is any cold or hollow soldering and rule out the problem. Especially check for C27,C36,C67.
 - B. If the above action does not work after the inspection, replace the main board.
- *T51 · Video can't be still or stopped*
 - ✓ Remote control
 - A. If the main body of the system works normally, then making sure that the battery of the Remote control has sufficient power, if it is not, replace the battery.
 - ✓ Main Board
 - A. Check to see if U17 is damaged, and check all parts following U17 to see if there is any cold or hollow soldering, short circuit, broken circuit, broken parts, parts missing and rule out the problem.
 - B. Check to see whether U17 is damaged.
 - C. If the above actions are not working, replace the Main Board.
- *T52 · Can't execute fast forward or rewind*
 - ✓ Main Board
 - A. Check to see if U17 is damaged, and check all parts following U17 to see if there is any cold or hollow soldering, short circuit, broken circuit, broken parts, parts missing and rule out the problem.
 - B. Check to see whether U17 is damaged.
 - C. If the above actions do not work after the inspection, it means the main board or F/W is bad. Replace the main board or re-burn the F/W (U11).
- *T53 · Panel button*
 - ✓ Main Board
 - A. Check U17 and 11-pin plug in jack CON2 to see if there is any cold or hollow soldering and reverse soldering of IC or parts missing.
 - B. If the above actions do not work after the inspection, check the 11pin cable to see if there is any damage.
 - C. If the above actions are not working, Replace the control board or the main board.
- *T61 · Can't enter the system setting*

- ✓ Main Board
 - A. Check U17 to see if there is any cold or hollow soldering and reverse soldering of IC or parts missing.
 - B. If the above actions do not work after the inspection, it means the main board or F/W is bad.
 - C. If the disk is abnormal, ask for a new version software .
- *T62 · System can't play or system down after setting*
 - ✓ Main Board
 - A. Check U17 to see if there is any cold or hollow soldering and reverse soldering of IC or parts missing.
 - B. If the above actions do not work after the inspection, it means the main board or F/W is bad. Replace the main board or re-burn the F/W (U11).
- *T71 · TFT image and color error*
 - ✓ Main Board
 - A. Check the 11-pin cable connected to the driver board to see if there is any problem of plugging. Rule out the problem.
 - B. Check devices after Y/C signal to see if there is any cold or hollow soldering and reverse soldering of IC or parts missing.
 - C. Check U17 to see if there is any cold or hollow soldering and reverse soldering of IC or parts missing.
 - D. If the above actions are not working, replace the Main Board.
 - ✓ Driver Board
 - A. Measure the voltages of VGH,VGE,VCC,VDD,VIN and VSS to see if they are correct.
 - B. Check VC1 to see if there is any cold or hollow soldering and reverse soldering of IC or parts missing.
 - C. Check Y1,Y2 to see if there is any cold or hollow soldering and reverse soldering of IC or parts missing.
 - D. If the above actions are not working, replace the Driver Board.
- *T72 · TFT image is black and white*
 - ✓ Main Board
 - A. Check the 11-pin cable connected to the driver board to see if there is any problem of plugging. Rule out the problem.
 - B. Check devices after Y/C signal to see if there is any cold or hollow soldering and reverse soldering of IC or parts missing.
 - C. Check U17 to see if there is any cold or hollow soldering and reverse soldering of IC or parts missing.
 - D. If the above actions are not working, replace the Main Board.
 - ✓ Driver Board

- A. Measure the voltages of VGH,VGE,VCC,VDD,VIN and VSS to see if they are correct.
 - B. Check VC1 to see if there is any cold or hollow soldering and reverse soldering of IC or parts missing.
 - C. Check the devices surrounding U1 and U201 to see if there is any cold or hollow soldering and reverse soldering of IC or parts missing.
 - D. Check Y1,Y2 to see if there is any cold or hollow soldering and reverse soldering of IC or parts missing.
 - E. If the above actions are not working, replace the Driver Board.
- *T73 · TFT image shakes or is distorted*
 - ✓ Main Board
 - A. Check the 11-pin cable connected to the driver board to see if there is any problem of plugging. Rule out the problem.
 - B. Check devices after Y/C signal to see if there is any cold or hollow soldering and reverse soldering of IC or parts missing.
 - C. Check U17 to see if there is any cold or hollow soldering and reverse soldering of IC or parts missing.
 - D. If the above actions are not working, replace the Main Board.
 - ✓ Driver Board
 - A. Measure the voltages of VGH,VGE,VCC,VDD,VIN and VSS to see if they are correct.
 - B. Check VC1 to see if there is any cold or hollow soldering and reverse soldering of IC or parts missing.
 - C. Check the devices surrounding U1 and U201 to see if there is any cold or hollow soldering and reverse soldering of IC or parts missing.
 - D. Check Y1,Y2 to see if there is any cold or hollow soldering and reverse soldering of IC or parts missing.
 - E. If the above actions are not working, replace the Driver Board.
 - *T74 · TFT PAL color strip*
 - ✓ Driver Board
 - A. Measure the voltages of VGH,VGE,VCC,VDD,VIN and VSS to see if they are correct.
 - B. Check VC1 to see if there is any cold or hollow soldering and reverse soldering of IC or parts missing.
 - C. Check the devices surrounding U1 and U201 to see if there is any cold or hollow soldering and reverse soldering of IC or parts missing.
 - D. Check Y1,Y2 to see if there is any cold or hollow soldering and reverse soldering

soldering of IC or parts missing.

F. Check Pin 1 to Pin 16 on U202 for any cold or hollow soldering and reverse soldering of IC or parts missing.

G. If the above actions are not working, replace the Driver Board.

● *T75 · TFT ripple*

✓ Main Board

A. Check the 13-pin cables connected to the driver board to see if there is any problem of plugging. Rule out the problem.

B. Check the 3-pin cable connected to the inverter board to see if there is any problem of plugging. Rule out the problem.

C. If the above actions are not working, replace the Main Board.

✓ Driver Board

A. Measure the voltage U1 to see if it is correct.

B. Check the devices surrounding VR202 to see if there is any cold or hollow soldering and reverse soldering of IC or parts missing.

C. If the above actions are not working, replace the Driver Board.

✓ Inverter Board

A. Check the 3-pin cable connected to the inverter board to see if there is any problem of plugging. Rule out the problem.

B. Check the sharing cable connected to the panel to see if there is any problem of plugging. Rule out the problem.

C. Check the high-voltage cable connected to the panel to see if there is any problem of plugging. Rule out the problem.

D. If the above actions are not working, replace the inverter board.