

# STAND BY & Multi BLOCK

## HOT

## COLD

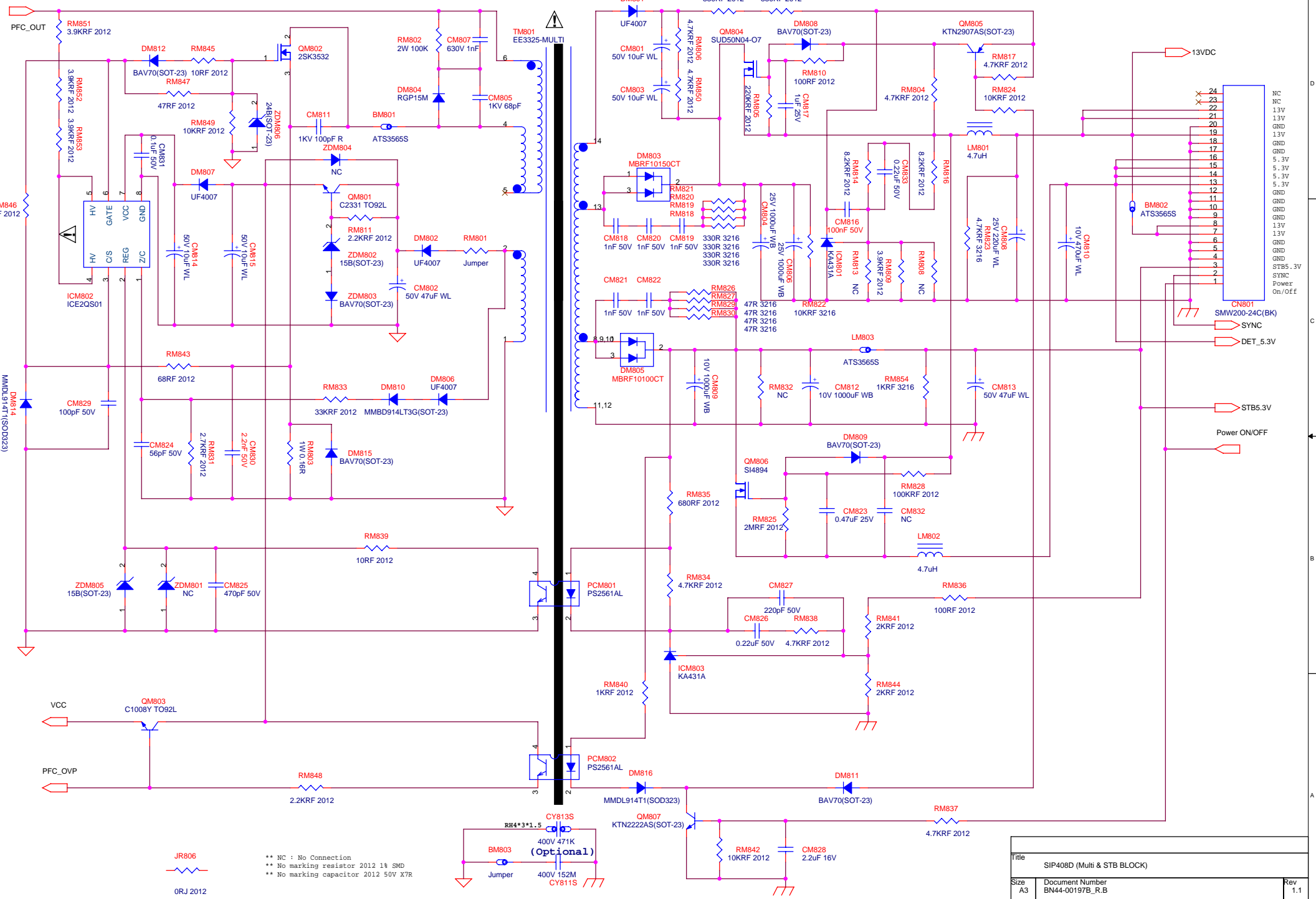

\*\* NC : No Connection  
 \*\* No marking resistor 2012 1% SMD  
 \*\* No marking capacitor 2012 50V X7R

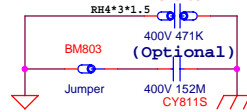

Title SIP408D (Multi & STB BLOCK)		
Size A3	Document Number BN44-00197B_R_B	Rev 1.1
Date: Monday, August 04, 2008	Sheet 0	of 3

# PFC BLOCK

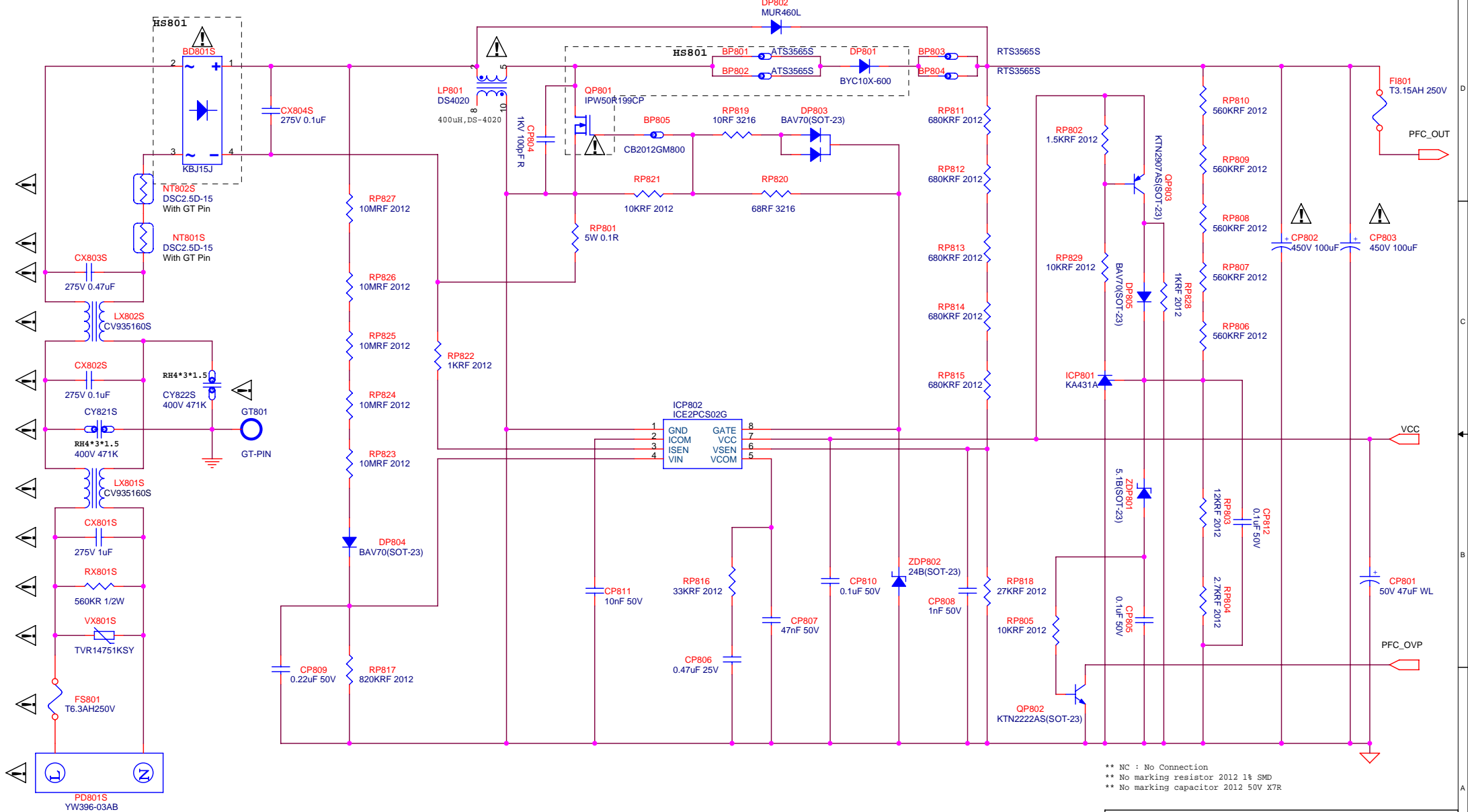

\*\* NC : No Connection  
 \*\* No marking resistor 2012 1% SMD  
 \*\* No marking capacitor 2012 50V X7R

Title		SIP408D (PFC BLOCK)	
Size	Document Number	Rev	
B	BN44-00197B_R.B	1.1	
Date:	Monday, August 04, 2008	Sheet	1 of 3

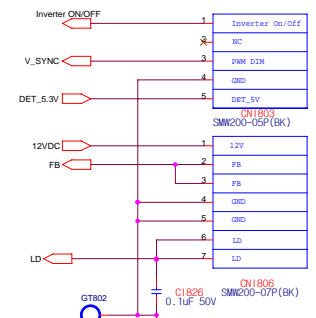
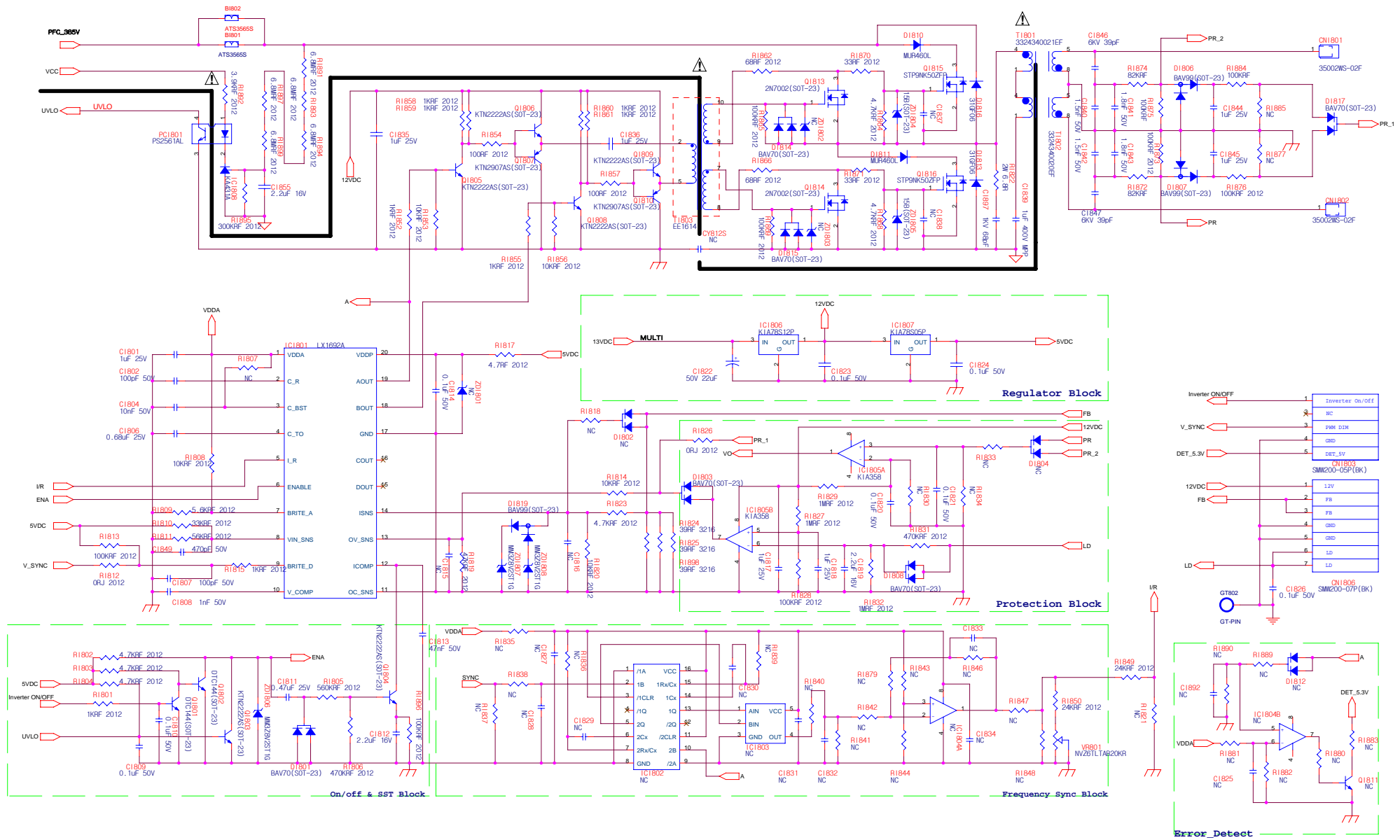

- JUMPER**
- J801 NC
  - J802 0RJ 2012
  - J803 0RJ 2012
  - J804 NC

\*\* NC : No Connection  
 \*\* No marking resistor 2012 1% SMD  
 \*\* No marking capacitor 2012 50V X7R

File: SIP408D(INVERTER BLOCK)			
Size: A2	Document Number: BNA4-001978_R.B	Rev: 1.1	
Date: Tuesday, August 05, 2008	Sheet: 3	of: 3	