



North/Latin America
Europe/Africa
Asia/Oceania

Internal Use Only

<http://aic.lgservice.com>
<http://eic.lgservice.com>
<http://biz.lgservice.com>

LED LCD TV

SERVICE MANUAL

CHASSIS : LD03R

MODEL: 42LX6500/650N 42X6500/650N-ZD
42LX6800/6900 42X6800/6900-ZD

CAUTION

BEFORE SERVICING THE CHASSIS,
READ THE SAFETY PRECAUTIONS IN THIS MANUAL.

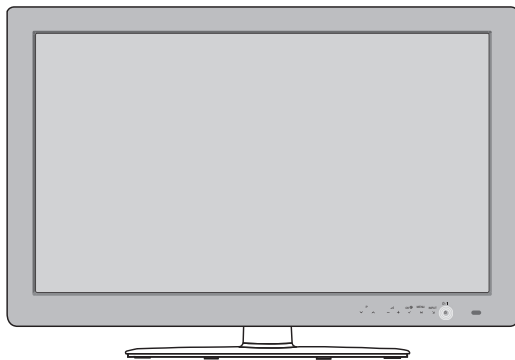

P/NO : MFL63748401 (1006-REV01)

Printed in Korea

CONTENTS

CONTENTS	2
PRODUCT SAFETY	3
SPECIFICATION	4
ADJUSTMENT INSTRUCTION	8
BLOCK DIAGRAM.....	17
EXPLODED VIEW	19
SCHEMATIC CIRCUIT DIAGRAM	

SAFETY PRECAUTIONS

IMPORTANT SAFETY NOTICE

Many electrical and mechanical parts in this chassis have special safety-related characteristics. These parts are identified by \triangle in the Schematic Diagram and Exploded View.

It is essential that these special safety parts should be replaced with the same components as recommended in this manual to prevent Shock, Fire, or other Hazards.

Do not modify the original design without permission of manufacturer.

General Guidance

An **isolation Transformer should always be used** during the servicing of a receiver whose chassis is not isolated from the AC power line. Use a transformer of adequate power rating as this protects the technician from accidents resulting in personal injury from electrical shocks.

It will also protect the receiver and its components from being damaged by accidental shorts of the circuitry that may be inadvertently introduced during the service operation.

If any fuse (or Fusible Resistor) in this TV receiver is blown, replace it with the specified.

When replacing a high wattage resistor (Oxide Metal Film Resistor, over 1 W), keep the resistor 10 mm away from PCB.

Keep wires away from high voltage or high temperature parts.

Before returning the receiver to the customer,

always perform an **AC leakage current check** on the exposed metallic parts of the cabinet, such as antennas, terminals, etc., to be sure the set is safe to operate without damage of electrical shock.

Leakage Current Cold Check(Antenna Cold Check)

With the instrument AC plug removed from AC source, connect an electrical jumper across the two AC plug prongs. Place the AC switch in the on position, connect one lead of ohm-meter to the AC plug prongs tied together and touch other ohm-meter lead in turn to each exposed metallic parts such as antenna terminals, phone jacks, etc.

If the exposed metallic part has a return path to the chassis, the measured resistance should be between 1 M Ω and 5.2 M Ω .

When the exposed metal has no return path to the chassis the reading must be infinite.

An other abnormality exists that must be corrected before the receiver is returned to the customer.

Leakage Current Hot Check (See below Figure)

Plug the AC cord directly into the AC outlet.

Do not use a line Isolation Transformer during this check.

Connect 1.5 K / 10 watt resistor in parallel with a 0.15 uF capacitor between a known good earth ground (Water Pipe, Conduit, etc.) and the exposed metallic parts.

Measure the AC voltage across the resistor using AC voltmeter with 1000 ohms/volt or more sensitivity.

Reverse plug the AC cord into the AC outlet and repeat AC voltage measurements for each exposed metallic part. Any voltage measured must not exceed 0.75 volt RMS which corresponds to 0.5 mA.

In case any measurement is out of the limits specified, there is possibility of shock hazard and the set must be checked and repaired before it is returned to the customer.

Leakage Current Hot Check circuit

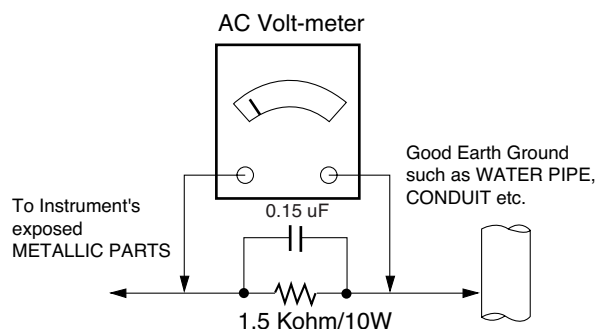

When 25A is impressed between Earth and 2nd Ground for 1 second, Resistance must be less than 0.1 Ω

*Base on Adjustment standard

SPECIFICATION

NOTE : Specifications and others are subject to change without notice for improvement.

1. Application range

This specification is applied to the LCD TV used LD03R chassis.

2. Requirement for Test

Each part is tested as below without special appointment.

- 1) Temperature: 25 °C ± 5 °C(77 °F ± 9 °F), CST: 40 °C ± 5 °C
- 2) Relative Humidity : 65 % ± 10 %
- 3) Power Voltage
: Standard input voltage (AC 100-240 V~ 50 / 60 Hz)
* Standard Voltage of each products is marked by models.
- 4) Specification and performance of each parts are followed each drawing and specification by part number in accordance with BOM.
- 5) The receiver must be operated for about 5 minutes prior to the adjustment.

3. Test method

- 1) Performance: LGE TV test method followed
- 2) Demanded other specification
 - Safety : CE, IEC specification
 - EMC :CE, IEC

4. Module General Specification

No.	Item	Specification	Remark
1	Display Screen Device	107 cm(42 inch) wide color display module	
2	Aspect Ratio	16:9	
3	LCD Module	107 cm(42 inch) TFT LCD FHD 240 Hz(Edge)	
4	Operating Environment	Temp. : 0 deg ~ 50 deg	
		Humidity : 20 % ~ 90 %	
5	Storage Environment	Temp. : -20 deg ~ 60 deg	
		Humidity : 10 ~ 90 %	
6	Input Voltage	AC 100-240V~, 50 / 60Hz	
7	Power Consumption	Power on (White)	LCD (Module) + Backlight(EDGE LED)
		LGD	
8	Module Size	973.2 (H) x 566.2 (V) x 10.8 mm(D)	
8	Pixel Pitch	0.4845 (H) x 0.4845 (V)	
9	Back Light	LED(EDGE)	
10	Display Colors	1.06 B(true) colors	
11	Coating	3H	

5. Module optical specification

No.	Item	Specification		Min.	Typ.	Max.	Remark
1.	Viewing Angle [CR>10]	Right/Left/Up/Down		89			CR > 10
2.	Luminance	2D	Luminance (cd/m ²)	360	450		
			Variation			1.3	MAX /MIN
		3D	Luminance (cd/m ²)	48	61		
3.	Contrast Ratio	CR		1000	1300		
4.	3D Cross talk	%			14	18	
5.	CIE Color Coordinates	White	Wx	Typ. -0.03	0.279	Typ. +0.03	
			Wy		0.292		
		RED	Xr		0.642		
			Yr		0.335		
		Green	Xg		0.308		
			Yg		0.602		
		Blue	Xb		0.156		
			Yb		0.061		

- 1) Standard Test Condition(The unit has been 'ON').
- 2) Stable for approximately 60 minutes in a dark environment at 25 °C.
- 3) The values specified are at approximate distance 50 cm from the LCD surface.

6. Component Video Input (Y, C_B/P_B, C_R/P_R)

No.	Specification				Remark
	Resolution	H-freq(kHz)	V-freq(Hz)		
1.	720x480	15.73	60.00	SDTV,DVD 480i	
2.	720x480	15.63	59.94	SDTV,DVD 480i	
3.	720x480	31.47	59.94	480p	
4.	720x480	31.50	60.00	480p	
5.	720x576	15.625	50.00	SDTV,DVD 625 Line	
6.	720x576	31.25	50.00	HDTV 576p	
7.	1280x720	45.00	50.00	HDTV 720p	
8.	1280x720	44.96	59.94	HDTV 720p	
9.	1280x720	45.00	60.00	HDTV 720p	
10.	1920x1080	31.25	50.00	HDTV 1080i	
11.	1920x1080	33.75	60.00	HDTV 1080i	
12.	1920x1080	33.72	59.94	HDTV 1080i	
13.	1920x1080	56.250	50	HDTV 1080p	
14.	1920x1080	67.5	60	HDTV 1080p	

7. RGB (PC)

No.	Specification				Proposed	Remarks
	Resolution	H-freq(kHz)	V-freq(Hz)	Pixel Clock(MHz)		
1.	720*400	31.468	70.08	28.321		For only DOS mode
2.	640*480	31.469	59.94	25.17	VESA	Input 848*480 60 Hz, 852*480 60 Hz -> 640*480 60 Hz Display
3.	800*600	37.879	60.31	40.00	VESA	
4.	1024*768	48.363	60.00	65.00	VESA(XGA)	
5.	1280*768	47.78	59.87	79.5	WXGA	
6.	1360*768	47.72	59.8	84.75	WXGA	
7.	1280*1024	63.595	60.0	108.875	SXGA	FHD model
8.	1920*1080	66.587	59.93	138.625	WUXGA	FHD model

8. HDMI Input (1) DTV Mode

No.	Resolution	H-freq(kHz)	V-freq.(Hz)	Pixel clock(MHz)	Proposed	Remark
1.	720*480	31.469 /31.5	59.94 /60	27.00/27.03	SDTV 480P	
2.	720*576	31.25	50	54	SDTV 576P	
3.	1280*720	37.500	50	74.25	HDTV 720P	
4.	1280*720	44.96 /45	59.94 /60	74.17/74.25	HDTV 720P	
5.	1920*1080	33.72 /33.75	59.94 /60	74.17/74.25	HDTV 1080I	
6.	1920*1080	28.125	50.00	74.25	HDTV 1080I	
7.	1920*1080	26.97 /27	23.97 /24	74.17/74.25	HDTV 1080P	
8.	1920*1080	33.716 /33.75	29.976 /30.00	74.25	HDTV 1080P	
9.	1920*1080	56.250	50	148.5	HDTV 1080P	
10.	1920*1080	67.43 /67.5	59.94 /60	148.35/148.50	HDTV 1080P	

(2) PC Mode

No.	Resolution	H-freq(kHz)	V-freq.(Hz)	Pixel clock(MHz)	Proposed	Remark
1.	720*400	31.468	70.08	28.321		HDCP
2.	640*480	31.469	59.94	25.17	VESA	HDCP
3.	800*600	37.879	60.31	40.00	VESA	HDCP
4.	1024*768	48.363	60.00	65.00	VESA(XGA)	HDCP
5.	1280*768	47.78	59.87	79.5	WXGA	HDCP
6.	1360*768	47.72	59.8	84.75	WXGA	HDCP
7.	1280*1024	63.595	60.0	108.875	SXGA	HDCP/FHD model
8.	1920*1080	67.5	60.00	138.625	WUXGA	HDCP/FHD model

9. 3D Mode - HDMI & USB

(1) HDMI Input (1.4)

No.	Resolution	H-freq(kHz)	V-freq.(Hz)	Pixel clock(MHz)	Proposed	3D input proposed mode
1	1920*1080	53.95 / 54	23.98 / 24	148.35/148.5	HDTV 1080P	Frame packing
2	1280*720	89.9 / 90	59.94/60	148.35/148.5	HDTV 720P	Frame packing
3	1280*720	75	50	148.5	HDTV 720P	Frame packing
4	1920*1080	67.5	60	148.5	HDTV 1080P	Side by Side(half), Top and bottom
5	1920*1080	56.3	50	148.5	HDTV 1080P	Side by Side(half), Top and bottom
6	1280*720	45	60	74.25	HDTV 720P	Side by Side(half), Top and Bottom
7	1280*720	37.5	50	74.25	HDTV 720P	Side by Side(half), Top and Bottom
8	1920*1080	33.7	60	74.25	HDTV 1080i	Side by Side(half), Top and Bottom
9	1920*1080	28.1	50	74.25	HDTV 1080i	Side by Side(half), Top and Bottom
10	1920*1080	27	24	74.25	HDTV 1080P	Side by Side(half), Top and Bottom
11	1920*1080	33.7	30	89.1	HDTV 1080P	Side by Side(half), Top and Bottom



(2) HDMI Input (1.3)

No.	Resolution	H-freq(kHz)	V-freq.(Hz)	Pixel clock(MHz)	Proposed	3D input proposed mode
1	1280*720	45.00	60.00	74.25	HDTV 720P	Side by Side, Top & Bottom
2	1280*720	37.500	50	74.25	HDTV 720P	Side by Side, Top & Bottom
3	1920*1080	33.75	60.00	74.25	HDTV 1080I	Side by Side, Top & Bottom
4	1920*1080	28.125	50.00	74.25	HDTV 1080I	Side by Side, Top & Bottom
5	1920*1080	27.00	24.00	74.25	HDTV 1080P	Side by Side, Top & Bottom, Checkerboard
6	1920*1080	33.75	30.00	74.25	HDTV 1080P	Side by Side, Top & Bottom, Checkerboard
7	1920*1080	67.50	60.00	148.5	HDTV 1080P	Side by Side, Top & Bottom, Checkerboard, Single Frame Sequential
8	1920*1080	56.250	50	148.5	HDTV 1080P	Side by Side, Top & Bottom, Checkerboard, Single Frame Sequential

(3) USB Input

No.	Resolution	H-freq(kHz)	V-freq.(Hz)	Pixel clock(MHz)	3D input proposed mode	Remark
1.	1920*1080	33.75	30.000	74.25	Side by Side Top & Bottom Checkerboard	HDTV 1080P

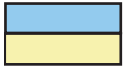
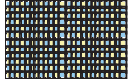
(4) 3D Input mode

No.	Side by Side	Top & Bottom	Checkerboard	Single Frame Sequential	Frame Packing
1.					

- MAC Address Download
 - Com 1,2,3,4 and 115200(Baud rate)
 - Port connection button click(1)

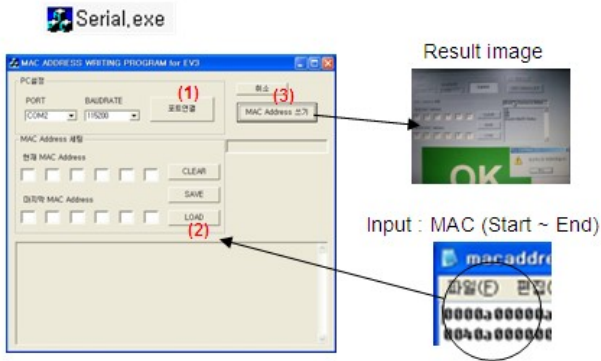

- Load button click(2) for MAC Address write.
- Start MAC Address write button(3)
- Check the OK Or NG

3.3. LAN

- Equipment & Condition
 - Each other connection to LAN Port of IP Hub and Jig

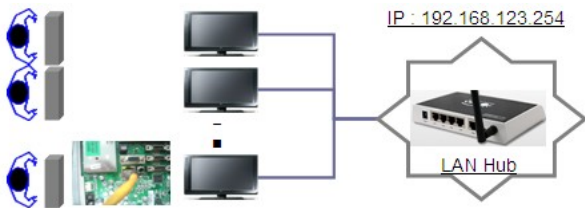

- LAN inspection solution
 - LAN Port connection with PCB
 - Network setting at MENU Mode of TV
 - setting automatic IP
 - Setting state confirmation
 - > If automatic setting is finished, you confirm IP and MAC Address.

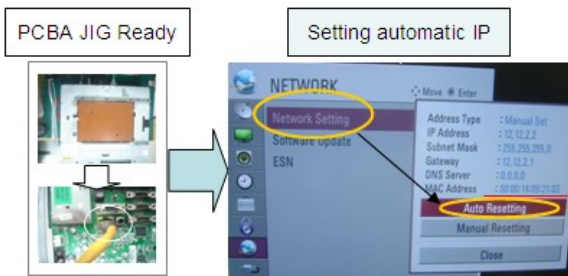

3.4. LAN PORT INSPECTION(PING TEST)

Connect SET -> LAN port == PC -> LAN Port



- Equipment setting
 - Play the LAN Port Test PROGRAM.
 - Input IP set up for an inspection to Test Program.
 - *IP Number : 12.12.2.2
- LAN PORT inspection (PING TEST)
 - Play the LAN Port Test Program.
 - Connect each other LAN Port Jack.
 - Play Test (F9) button and confirm OK Message.
 - Remove LAN CABLE



3.5. V-COM Adjust(Only LGD(M+S) Module)

- Why need Vcom adjustment?
- The Vcom (Common Voltage) is a Reference Voltage of Liquid Crystal Driving.
 - > Liquid Crystal need for Polarity Change with every frame.

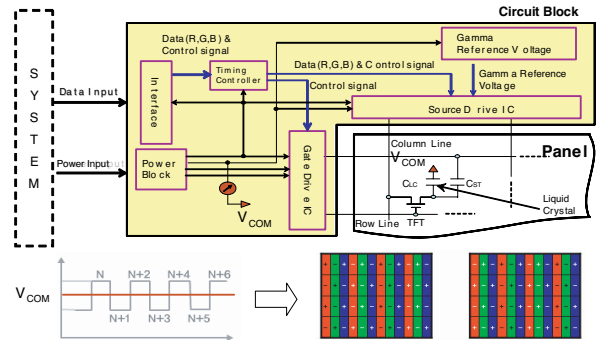

- Adjust sequence

- Press the PIP key of the ADJ remote control. (This PIP key is hot key to enter the VCOM adjusting mode)
(Or After enter Service Mode by pushing “ADJ” key, then Enter V-Com Adjust mode by pushing “▶” key at “10. V-Com”)
- As pushing the right or the left button on the remote control, And find the V-COM value Which is no or minimized the Flicker.
(If there is no flicker at default value, Press the exit key and finish the VCOM adjustment.)
- Push the OK key to store value. Then the message “Saving OK” is pop.
- Press the exit key to finish VCOM adjustment.



[Visual Adjust and control the Voltage level]

3.6. Model name & serial number download

(1) Model name & Serial number D/L

- Press “Power on” key of service remote control.(Baud rate : 115200 bps)
- Connect RS232 Signal Cable to RS-232 Jack.
- Write Serial number by use RS-232.
- Must check the serial number at Instart menu.

(2) Method & notice

- A. Serial number D/L is using of scan equipment.
- B. Setting of scan equipment operated by Manufacturing Technology Group.
- C. Serial number D/L must be conformed when it is produced in production line, because serial number D/L is mandatory by D-book 4.0

* Manual Download (Model Name and Serial Number)

If the TV set is downloaded by OTA or service man, sometimes model name or serial number is initialized.(Not always)

There is impossible to download by bar code scan, so It need Manual download.

- a. Press the 'instart' key of ADJ remote control.
- b. Go to the menu '5.Model Number D/L' like below photo.
- c. Input the Factory model name(ex 42LD450-ZA) or Serial number like photo.

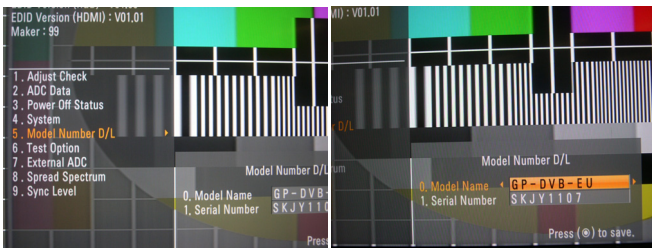

- d. Check the model name Instart menu -> Factory name displayed (ex 42LE7500-ZA)
- e. Check the Diagnostics (DTV country only) -> Buyer model displayed (ex 42LE7500-ZA)

3.7. CI+ Key Download method

(1) Download Procedure

- 1) Press "Power on" button of a service R/C.(Baud rate : 115200 bps)
- 2) Connect RS232-C Signal Cable.
- 3) Write CI+ Key through RS-232-C.
- 4) Check whether the key was downloaded or not at 'In Start' menu. (Refer to below).



=> Check the Download to CI+ Key value in LGset.

1. check the method of CI+ Key value
 - a. check the method on Instart menu
 - b. check the method of RS232C Command
 - 1) into the main ass'y mode (RS232 : aa 00 00)

CMD 1	CMD 2	Data 0	
A	A	0	0

- 2) check the key download for transmitted command (RS232 : ci 00 10)

CMD 1	CMD 2	Data 0	
C	I	1	0

- 3) result value
 - normally status for download : OKx
 - abnormally status for download : NGx

2. Check the method of CI+ Key value (RS232)
 - 1) into the main ass'y mode (RS232 : aa 00 00)

CMD 1	CMD 2	Data 0	
A	A	0	0

- 2) Check the method of CI+ key by command (RS232 : ci 00 20)

CMD 1	CMD 2	Data 0	
C	I	2	0

- 3) Result value

i 01 OK 1d1852d21c1ed5dcx

→ CI+ key Value

4. Manual Adjustment

4.1. ADC(GP2) Adjustment

4.1.1. Overview

ADC adjustment is needed to find the optimum black level and gain in Analog-to-Digital device and to compensate RGB deviation.

4.1.2. Equipment & Condition

- (1) Adjust Remote control
- (2) 801GF(802B, 802F, 802R) or MSPG925FA Pattern Generator
 - Resolution :
 - 480i, 720*480 (MSPG-925FA -> Model: 209, Pattern: 65)
 - 480i
 - 1080p, 1920*1080 (MSPG-925FA -> Model: 225, Pattern: 65) - 1080p
 - Pattern : Horizontal 100% Color Bar Pattern
 - Pattern level: 0.7 ± 0.1 Vp-p
 - Image

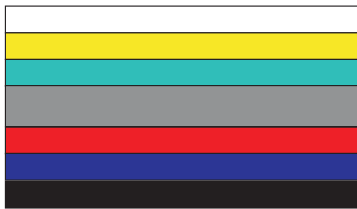

(3) Must use standard cable

4.1.3. Adjust method

- (1) ADC 480i, 1080p Comp1
 - 1) Check connected condition of Comp1 cable to the equipment
 - 2) Give a 480i, 1080p Mode, Horizontal 100% Color Bar Pattern to Comp1.
 - (MSPG-925FA -> Model: 209, Pattern: 65) - 480i
 - (MSPG-925FA -> Model: 225, Pattern: 65) - 1080p
 - 3) Change input mode as Component1 and picture mode as "Standard"
 - 4) Press the In-start Key on the ADJ remote after at least 1 min of signal reception. Then, select 7. External ADC -> 1. COMP 1080p on the menu. Press enter key. The adjustment will start automatically.
 - 5) If ADC calibration is successful, "ADC RGB Success" is displayed.
 - If ADC calibration is failure, "ADC RGB Fail" is displayed.
 - 6) If ADC calibration is failure, after recheck ADC pattern or condition retry calibration Error message refer to 5).
- (2) ADC 1920*1080 RGB
 - 1) Check connected condition of Component & RGB cable to the equipment
 - 2) Give a 1920*1080 Mode, 100 % Horizontal Color Bar Pattern to RGB port.
 - (MSPG-925 Series -> model: 225 , pattern: 65)
 - 3) Change input mode as RGB and picture mode as "Standard".
 - 4) Press the In-start Key on the ADJ remote after at least 1 min of signal reception. Then, select 7. External ADC -> 1. COMP 1080p on the menu. Press enter key. The adjustment will start automatically.
 - 5) If ADC calibration is successful, "ADC RGB Success" is displayed.
 - If ADC calibration is failure, "ADC RGB Fail" is displayed.
 - 6) If ADC calibration is failure, after recheck ADC pattern or condition retry calibration Error message refer to 5).

4.2. EDID(The Extended Display Identification Data)/DDC(Display Data Channel) download

(1) Overview

It is a VESA regulation. A PC or a MNT will display an optimal resolution through information sharing without any necessity of user input. It is a realization of "Plug and Play".

(2) Equipment

- Adjust remote control
- Since embedded EDID data is used, EDID download JIG, HDMI cable and D-sub cable are not need.

(3)Download method

- 1) Press Adj. key on the Adj. R/C, then select "10.EDID D/L", By pressing Enter key, enter EDID D/L menu.
- 2) Select [Start] button by pressing Enter key, HDMI1 / HDMI2 / HDMI3 / HDMI4 / RGB are Writing and display OK or NG.

For Analog EDID	For HDMI EDID	
D-sub to D-sub	DVI-D to HDMI or HDMI to HDMI	
		

(4) EDID DATA

■ HDMI

	0x00	0x01	0x02	0x03	0x04	0x05	0x06	0x07	0x08	0x09	0x0A	0x0B	0x0C	0x0D	0x0E	0x0F
0x00	00	FF	FF	FF	FF	FF	FF	00	1E	6D						
0x01			01	03	80	10	09	78	0A	EE	91	A3	54	4C	99	26
0x02	0F	50	54	A1	08	00	71	4F	81	80	01	01	01	01	01	01
0x03	01	01	01	01	01	01	02	3A	80	18	71	38	2D	40	58	2C
0x04	45	00	A0	5A	00	00	00	1E	01	1D	00	72	51	D0	1E	20
0x05	6E	28	55	00	A0	5A	00	00	00	1E	00	00	00	FD	00	3A
0x06	3E	1E	53	10	00	0A	20	20	20	20	20	20				
0x07															01	1
0x08	02	03	37	F1	4E	10	1F	84	13	05	14	03	02	12	20	21
0x09	22	15	01	26	15	07	50	09	57	07						
0x0A																
0x0B				E3	05	03	01	01	1D	80	18	71	1C	16	20	58
0x0C	2C	25	00	A0	5A	00	00	00	9E	01	1D	00	80	51	D0	1A
0x0D	20	6E	88	55	00	A0	5A	00	00	00	1A	02	3A	80	18	71
0x0E	38	2D	40	58	2C	45	00	A0	5A	00	00	00	1E	00	00	00
0x0F	00	00	00	00	00	00	00	00	00	00	00	00	00	00	00	2

■ RGB

	0x00	0x01	0x02	0x03	0x04	0x05	0x06	0x07	0x08	0x09	0x0A	0x0B	0x0C	0x0D	0x0E	0x0F
0x00	00	FF	FF	FF	FF	FF	FF	00	1E	6D						
0x01			01	03	68	10	09	78	0A	EE	91	A3	54	4C	99	26
0x02	0F	50	54	A1	08	00	81	80	61	40	45	40	31	40	01	01
0x03	01	01	01	01	01	01	02	3A	80	18	71	38	2D	40	58	2C
0x04	45	00	A0	5A	00	00	00	1E	01	1D	00	72	51	D0	1E	20
0x05	6E	28	55	00	A0	5A	00	00	00	1E	00	00	00	FD	00	3A
0x06	3E	1E	53	10	00	0A	20	20	20	20	20	20				
0x07															00	3

■ Reference

- HDMI1 ~ HDMI4 / RGB
- In the data of EDID, bellows may be different by S/W or Input mode.

Product ID

Model Name	HEX	EDID Table	DDC Function
ALL	0001	0100	Analog
	0001	0100	Digital

Serial No. : Controlled on product line

Month, Year: Controlled on production line:

ex) Monthly : '01' -> '01'

Year : '2010' -> '14'

Model Name(Hex):

MODEL	MODEL NAME(HEX)
all	00 00 00 FC 00 4C 47 20 54 56 0A 20 20 20 20 20 20

Checksum: Changeable by total EDID data.

INPUT	1	2	3
HDMI1	D7	CB	X
HDMI2	D7	BB	X
HDMI3	D7	AB	X
HDMI4	D7	9B	X
HDMI5	X	X	1D

Vendor Specific(HDMI)

INPUT	MODEL NAME(HEX)
HDMI1	78 03 0C 00 10 00 B8 2D 20 C0 0E 01 40 0A 3C 08 10 18 10 98 10 58 10 38 10
HDMI2	78 03 0C 00 20 00 B8 2D 20 C0 0E 01 40 0A 3C 08 10 18 10 98 10 58 10 38 10
HDMI3	78 03 0C 00 30 00 B8 2D 20 C0 0E 01 40 0A 3C 08 10 18 10 98 10 58 10 38 10
HDMI4	78 03 0C 00 40 00 B8 2D 20 C0 0E 01 40 0A 3C 08 10 18 10 98 10 58 10 38 10
HDMI5	78 03 0C 00 50 00 B8 2D 20 C0 0E 01 40 0A 3C 08 10 18 10 98 10 58 10 38 10

4.3. White Balance Adjustment

4.3.1 Overview

- (1) W/B adj. Objective & How-it-works
- (2) Objective: To reduce each Panel's W/B deviation
- (3) How-it-works : When R/G/B gain in the OSD is at 192, it means the panel is at its Full Dynamic Range. In order to prevent saturation of Full Dynamic range and data, one of R/G/B is fixed at 192, and the other two is lowered to find the desired value.
- (4) Adj. condition : normal temperature
 - 1) Surrounding Temperature : 25 °C ± 5 °C
 - 2) Warm-up time: About 5 Min
 - 3) Surrounding Humidity : 20 % ~ 80 %

4.3.2 Equipment

- 1) Color Analyzer: CA-210 (LED Module : CH 14)
- 2) Adj. Computer(During auto adj., RS-232C protocol is needed)
- 3) Adjust Remote control
- 4) Video Signal Generator MSPG-925F 720p/216-Gray (Model:217, Pattern:78)
-> Only when internal pattern is not available

■ Color Analyzer Matrix should be calibrated using CS-1000

4.3.3. Equipment connection MAP

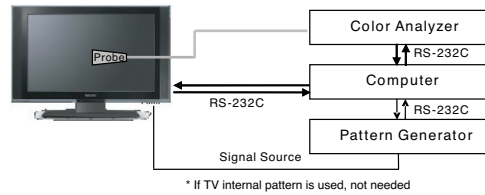

4.3.4. Adj. Command (Protocol)

<Command Format>

START [6E] [A] [50] [A] [LEN] [A] [03] [A] [CMD] [A] [00] [A] [VAL] [A] [CS] [A] [STOP]

- LEN: Number of Data Byte to be sent
 - CMD: Command
 - VAL: FOS Data value
 - CS: Checksum of sent data
 - A: Acknowledge
- Ex) [Send: JA_00_DD] / [Ack: A_00_okDDX]

■ RS-232C Command used during auto-adj.

RS-232C COMMAND			Explanation
[CMD]	ID	DATA]	
wb	00	00	Begin White Balance adj.
wb	00	10	Gain adj.(internal white pattern)
wb	00	1f	Gain adj. completed
wb	00	20	Offset adj.(internal white pattern)
wb	00	2f	Offset adj. completed
wb	00	ff	End White Balance adj.(Internal pattern disappears)

- Ex) wb 00 00 -> Begin white balance auto-adj.
 wb 00 10 -> Gain adj.
 ja 00 ff -> Adj. data
 jb 00 c0
 ...
 ...
 wb 00 1f -> Gain adj. completed
 *(wb 00 20(Start), wb 00 2f(completed)) -> Off-set adj.
 wb 00 ff -> End white balance auto-adj.

■ Adj. Map

	ITEM	Command		Data Range(Hex.)		Default(Decimal)
		Cmd 1	Cmd 2	Min	Max	
Cool	R-Gain	j	g	00	C0	
	G-Gain	j	h	00	C0	
	B-Gain	j	i	00	C0	
	R-Cut					
	G-Cut					
Medium	R-Gain	j	a	00	C0	
	G-Gain	j	b	00	C0	
	B-Gain	j	c	00	C0	
	R-Cut					
	G-Cut					
Warm	R-Gain	j	d	00	C0	
	G-Gain	j	e	00	C0	
	B-Gain	j	f	00	C0	
	R-Cut					
	G-Cut					

4.3.5. Adj. method

- (1) Auto adj. method
 - 1) Set TV in adj. mode using POWER ON key.
 - 2) Zero calibrate probe then place it on the center of the Display.
 - 3) Connect Cable (RS-232C)
 - 4) Select mode in adj. Program and begin adjustment.
 - 5) When adj. is complete (OK Sing), check adj. status pre mode. (Warm, Medium, Cool)
 - 6) Remove probe and RS-232C cable to complete adj.

■ W/B Adj. must begin as start command “wb 00 00”, and finish as end command “wb 00 ff”, and Adj. offset if need.

- (2) Manual adj. method
 - 1) Set TV in Adj. mode using POWER ON
 - 2) Zero Calibrate the probe of Color Analyzer, then place it on the center of LCD module within 10cm of the surface.
 - 3) Press ADJ key -> EZ adjust using adj. R/C -> 7. White-Balance then press the cursor to the right (KEY ►).
(When KEY(►) is pressed 216 Gray internal pattern will be displayed)
 - 4) One of R Gain / G Gain / B Gain should be fixed at 192, and the rest will be lowered to meet the desired value.
 - 5) Adj. is performed in COOL, MEDIUM, WARM 3 modes of color temperature.

■ If internal pattern is not available, use RF input. In EZ Adj. menu 7.White Balance, you can select one of 2 Test-pattern: ON, OFF. Default is inner(ON). By selecting OFF, you can adjust using RF signal in 216 Gray pattern.

- Adj. condition and cautionary items
- 1) Lighting condition in surrounding area
Surrounding lighting should be lower 10 lux. Try to isolate adj. area into dark surrounding.
 - 2) Probe location
: Color Analyzer (CA-210) probe should be within 10cm and perpendicular of the module surface (80°~100°)
 - 3) Aging time
 - After Aging Start, Keep the Power ON status during 5 Minutes.
 - In case of LCD, Back-light on should be checked using no signal or Full-white pattern.

4.3.6. Reference (White Balance Adj. coordinate and temperature)

- Luminance : 216 Gray
- Standard color coordinate and temperature using CS-1000 (over 26 inch)

Mode	Color Coordination		Temp	ΔUV
	x	y		
COOL	0.269	0.273	13000 K	0.0000
MEDIUM	0.285	0.293	9300 K	0.0000
WARM	0.313	0.329	6500 K	0.0000

■ Standard color coordinate and temperature using CA-210(CH 9)

Mode	Color Coordination		Temp	ΔUV
	x	y		
COOL	0.269 ± 0.002	0.273 ± 0.002	13000 K	0.0000
MEDIUM	0.285 ± 0.002	0.293 ± 0.002	9300 K	0.0000
WARM	0.313 ± 0.002	0.329 ± 0.002	6500 K	0.0000

4.3.7. IOP & Edge LED White balance table

■ IOP & Edge LED module change color coordinate because of aging time.

■ apply under the color coordinate table, for compensated aging time.

- EDGE LED(LX65)

GP2	Aging Time (Min.)	Cool		Medium		Warm	
		X	Y	X	Y	X	Y
			269	273	285	293	313
1	0-2	280	291	296	311	319	340
2	3-5	278	288	294	308	317	338
3	6-9	276	285	292	305	315	335
4	10-15	274	282	290	302	313	332
5	20-35	273	279	289	299	312	329
6	36-49	270	276	287	296	310	326
7	50-79	269	273	286	293	308	323
8	Over 80	269	273	285	293	308	323

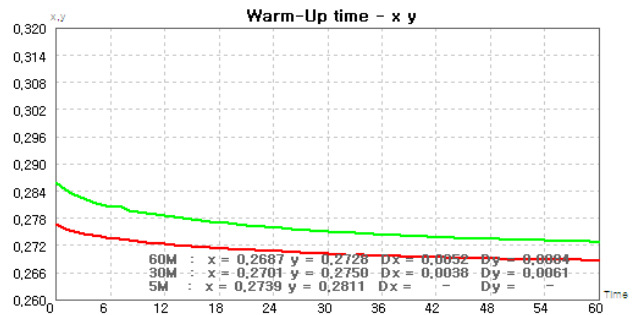

4.4. Wireless function check

- Step 1) Connect set and Dongle of Wireless to Cable of HDMI & TTA 20Pin
- Step 2) At OSD of SET, check the message like Fig.3
- Step 3) Detach Cable of Wireless Dongle



Fig.1
<Dongle>

Connect



Fig.2
<Wireless Ready Set>

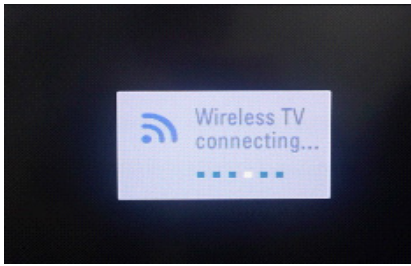
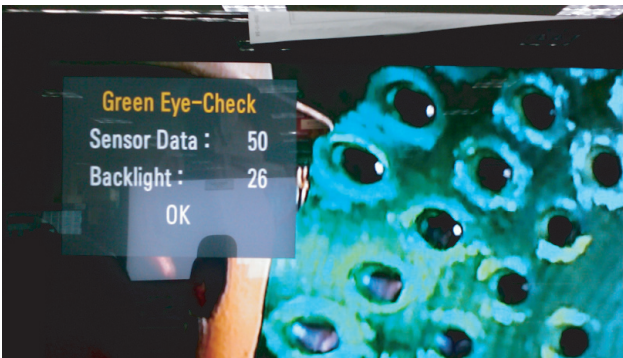

Fig.3 Connect the Dongle
(Dongle Connection Display)

4.5. EYE-Q function check

- Step 1) Turn on TV
- Step 2) Press EYE key of Adj. R/C
- Step 3) Cover the Eye Q II sensor on the front of the using your hand and wait for 6 seconds
- Step 4) Confirm that R/G/B value is lower than 10 of the "Raw Data (Sensor data, Back light)". If after 6 seconds, R/G/B value is not lower than 10, replace Eye Q II sensor.
- Step 5) Remove your hand from the Eye Q II sensor and wait for 6 seconds.
- Step 6) Confirm that "ok" pop up. If change is not seen, replace Eye Q II sensor.



4.6. Local Dimming Function Check

- Step 1) Turn on TV.
- Step 2) At the Local Dimming mode, module Edge Backlight moving right to left Back light of IOP module moving.
- Step 3) Confirm the Local Dimming mode.
- Step 4) Press "exit" key

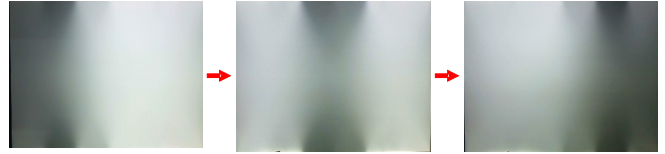

Local Dimming Demo (Edge LED Model)



Local Dimming Demo (IOP Model)

4.7. 3D function test

(Pattern Generator MSHG-600, MSPG-6100 [Support HDMI 1.4])
* HDMI mode No. 872, pattern No. 83)

- 1) Please input 3D test pattern like below



- 2) When 3D OSD appear automatically, then select OK button.



- 3) Don't wear a 3D Glasses, Check the picture like below.



4.8. IR emitter inspection

- (1) Start 3D pattern inspection
- (2) If IR emitter signal is correctly received to IR receiver, the lamp of IR tester turn on

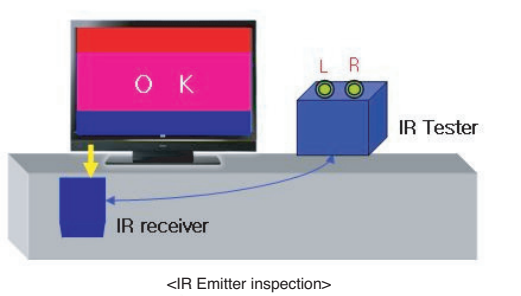

<IR Tester Lamp turned off(NG)> <IR Tester Lamp turned on(OK)>

4.9. Option selection per country

- (1) Overview
 - Option selection is only done for models in Non-EU.
 - Applied model: LD03D/03E Chassis applied EU model.
- (2) Method
 - 1) Press ADJ key on the Adj. Remote Control, then select Country Group Menu.
 - 2) Depending on destination, select Country Group Code 04 or Country Group EU then on the lower Country option, select US, CA, MX. Selection is done using +, - or ►◀ KEY.

4.10. Tool Option selection

- Method : Press Adj. key on the Adj. Remote Control, then select Tool option.

Mode	Tool 1	Tool 2	Tool 3	Tool 4	Tool 5
42LX6500	33760	31795	54316	22956	2874

4.11. Ship-out mode check(In-stop)

After final inspection, press IN-STOP key of the Adj. R/C and check that the unit goes to Stand-by mode.

5. GND and Internal Pressure check

5.1. Method

- 1) GND & Internal Pressure auto-check preparation
 - Check that Power Cord is fully inserted to the SET. (If loose, re-insert)
- 2) Perform GND & Internal Pressure auto-check
 - Unit fully inserted Power cord, Antenna cable and A/V arrive to the auto-check process.
 - Connect D-terminal to AV JACK TESTER
 - Auto CONTROLLER(GWS103-4) ON
 - Perform GND TEST
 - If NG, Buzzer will sound to inform the operator.
 - If OK, changeover to I/P check automatically. (Remove CORD, A/V form AV JACK BOX)
 - Perform I/P test
 - If NG, Buzzer will sound to inform the operator.
 - If OK, Good lamp will lit up and the stopper will allow the pallet to move on to next process.

5.2. Checkpoint

- TEST voltage
 - GND: 1.5KV/min at 100mA
 - SIGNAL: 3KV/min at 100mA
- TEST time: 1 second
- TEST POINT
 - GND TEST = POWER CORD GND & SIGNAL CABLE METAL GND
 - Internal Pressure TEST = POWER CORD GND & LIVE & NEUTRAL
- LEAKAGE CURRENT: At 0.5mArms

6. Audio

Measurement condition:

1. RF input: Mono, 1KHz sine wave signal, 100% Modulation
2. CVBS, Component: 1KHz sine wave signal 0.4Vrms
3. RGB PC: 1KHz sine wave signal 0.7Vrms

No.	Item	Min.	Typ.	Max.	Unit	
1.	Audio practical max Output, L/R (Distortion=10 % max Output)	4.5	5	6	W	EQ Off AVL Off
			6.33	6.93	Vrms	Clear Voice Off
2.	Speaker (8 Ω Impedance)		5	7	W	EQ On AVL On Clear Voice On

7. USB S/W Download (option, Service only)

- 1) Put the USB Stick to the USB socket
- 2) Automatically detecting update file in USB Stick
 - If your downloaded program version in USB Stick is Low, it didn't work. But your downloaded version is High, USB data is automatically detecting
- 3) Show the message "Copying files from memory"

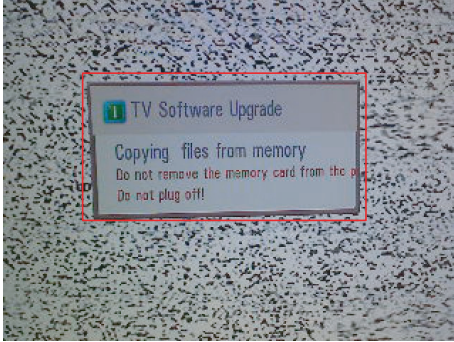

- 4) Updating is starting.

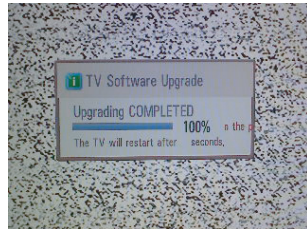
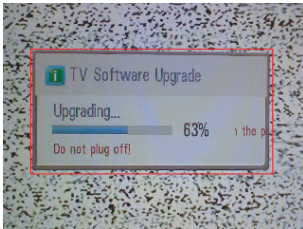

- 5) Updating Completed, The TV will restart automatically
- 6) If your TV is turned on, check your updated version and Tool option. (explain the Tool option, next stage)
 - * If downloading version is more high than your TV have, TV can lost all channel data. In this case, you have to channel recover. if all channel data is cleared, you didn't have a DTV/ATV test on production line.
 - * After downloading, have to adjust TOOL OPTION again.
 - 1) Push "IN-START" key in service remote control.
 - 2) Select "Tool Option 1" and Push "OK" button.
 - 3) Push in the number. (Each model has their number.)

BLOCK DIAGRAM

1. MAIN

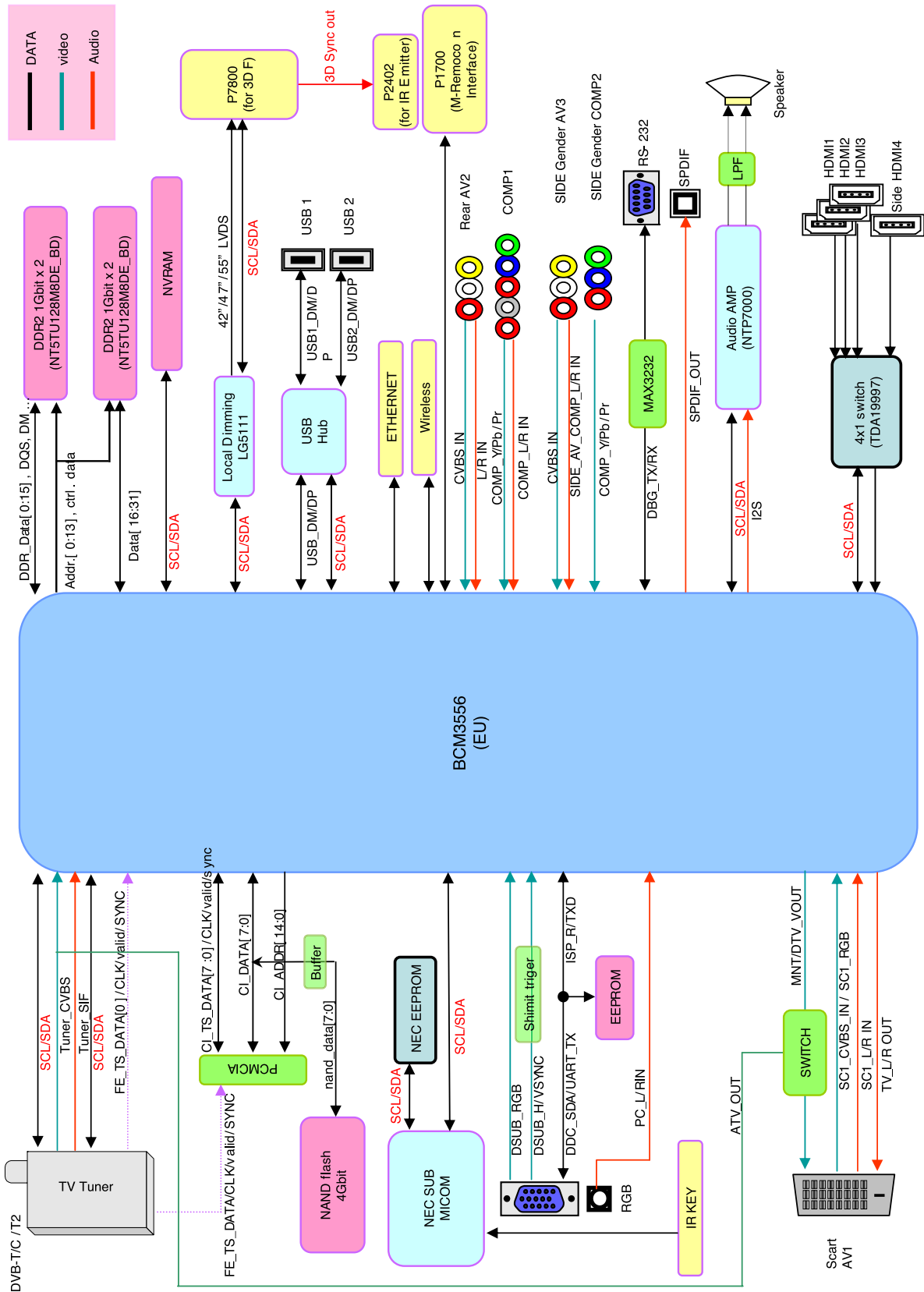

2. 3F BOARD

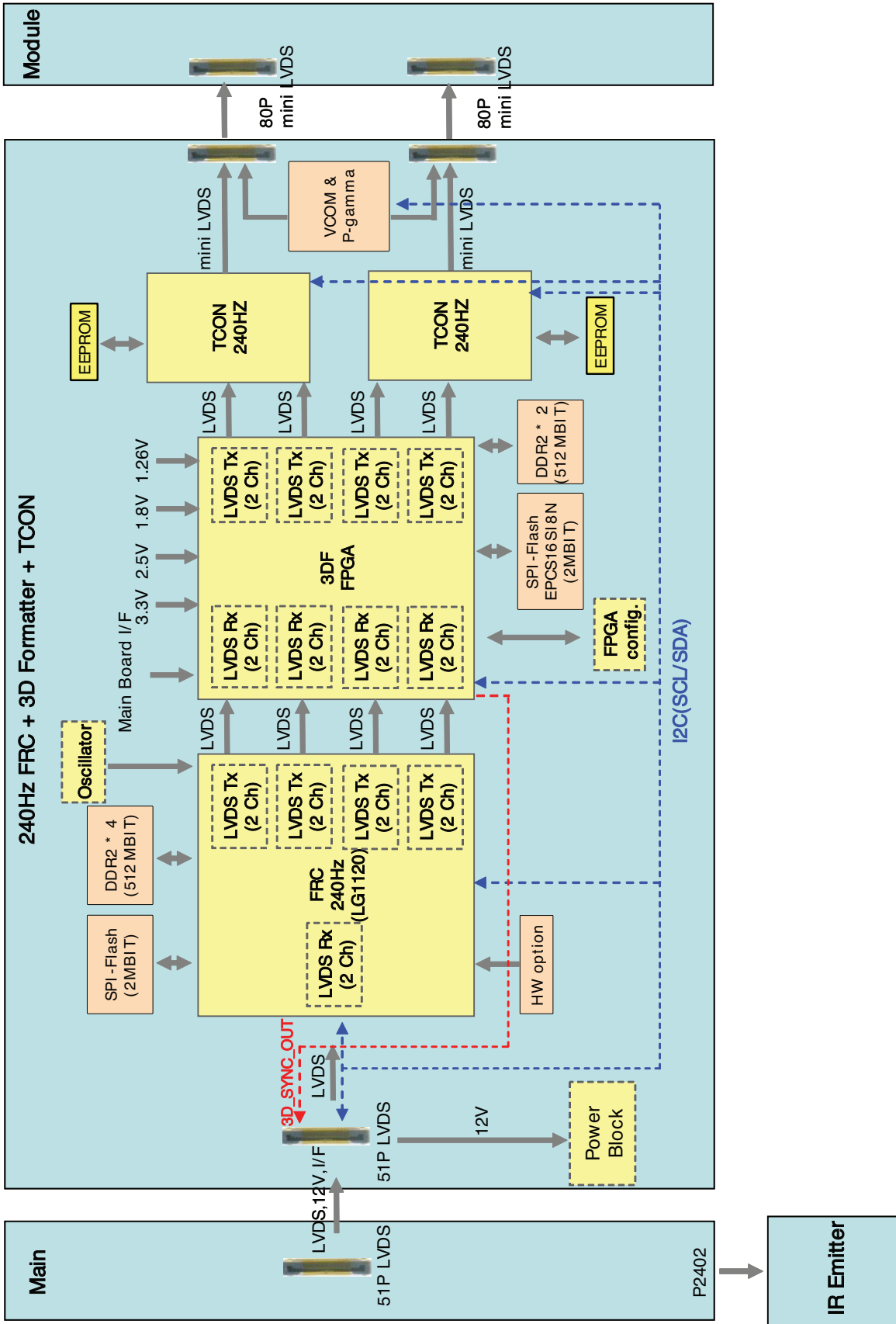

EXPLODED VIEW

IMPORTANT SAFETY NOTICE

Many electrical and mechanical parts in this chassis have special safety-related characteristics. These parts are identified by Δ in the Schematic Diagram and EXPLODED VIEW. It is essential that these special safety parts should be replaced with the same components as recommended in this manual to prevent X-RADIATION, Shock, Fire, or other Hazards. Do not modify the original design without permission of manufacturer.

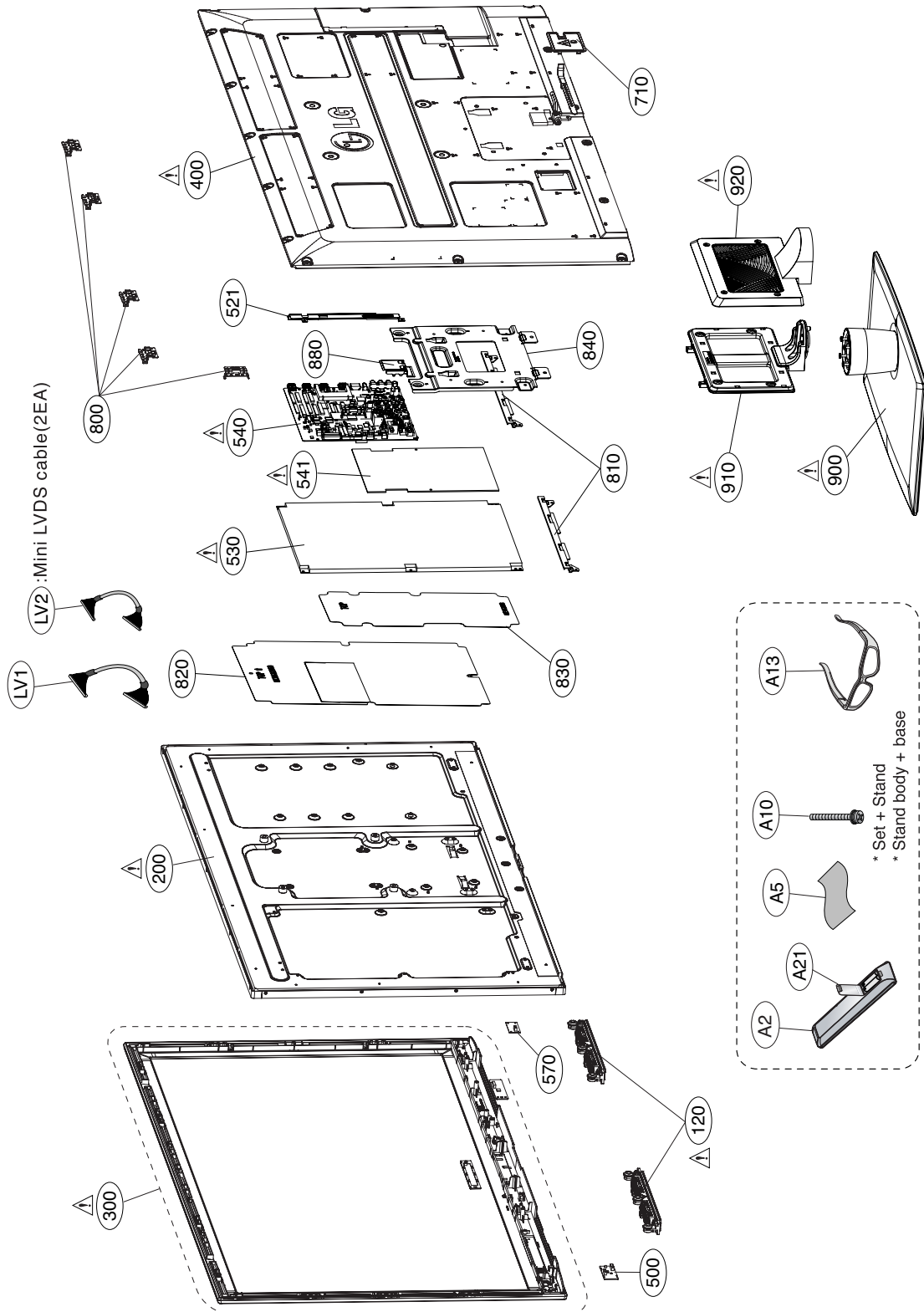

RESET

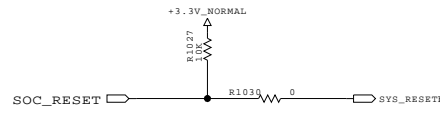

NVRAM

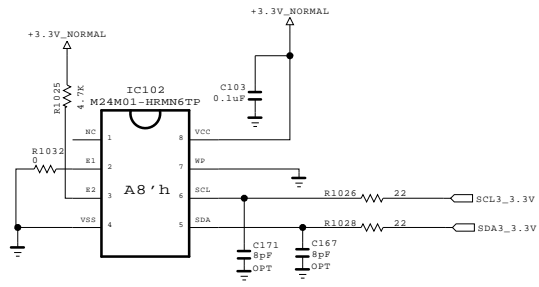

Boot Strap

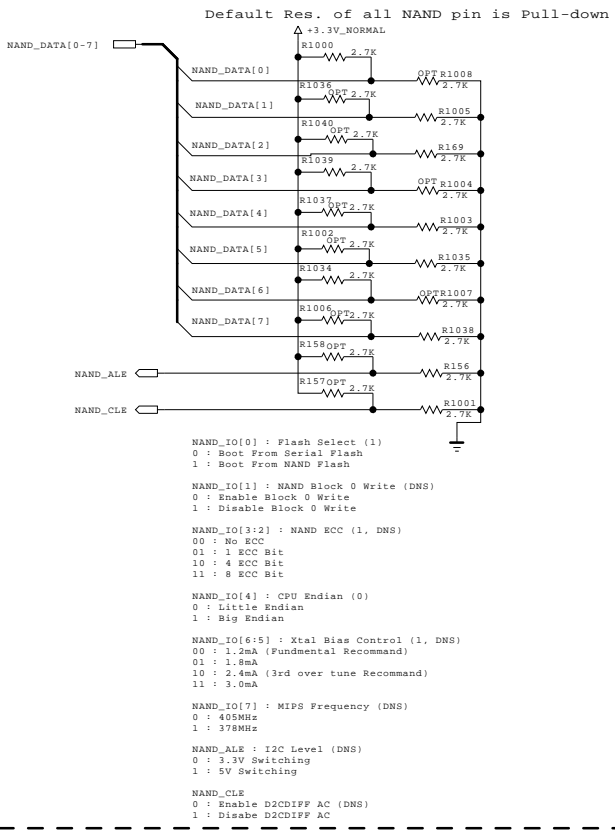

* NAND FLASH MEMORY 4Gbit (512M for BB)

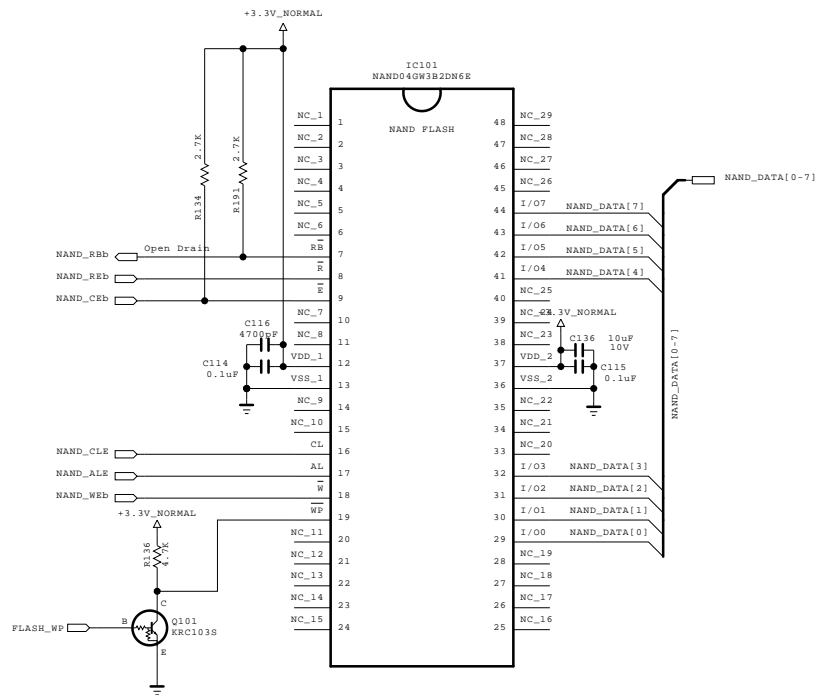

THE Δ SYMBOL MARK OF THIS SCHEMATIC DIAGRAM INCORPORATES SPECIAL FEATURES IMPORTANT FOR PROTECTION FROM X-RADIATION. FILRE AND ELECTRICAL SHOCK HAZARDS, WHEN SERVICING IF IS ESSENTIAL THAT ONLY MANUFACTURES SPECIFIED PARTS BE USED FOR THE CRITICAL COMPONENTS IN THE Δ SYMBOL MARK OF THE SCHEMATIC.

SECRET
LGElectronics



MODEL BLOCK	BCM (EUROBBTV)	DATE SHEET	2009.06.18
	BCM3556 & NAND FLASH		1 /

EXT_IRQ : GPIO_00, GPIO_01, GPIO_02, GPIO_11, GPIO_11, GPIO_39
 IR_INT : GPIO_23
 IR1_IN : GPIO_25
 IR2_IN : GPIO_29
 IR_OUT : GPIO_26
 PWM0 : GPIO_24
 PWM1 : GPIO_09

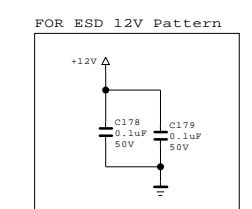
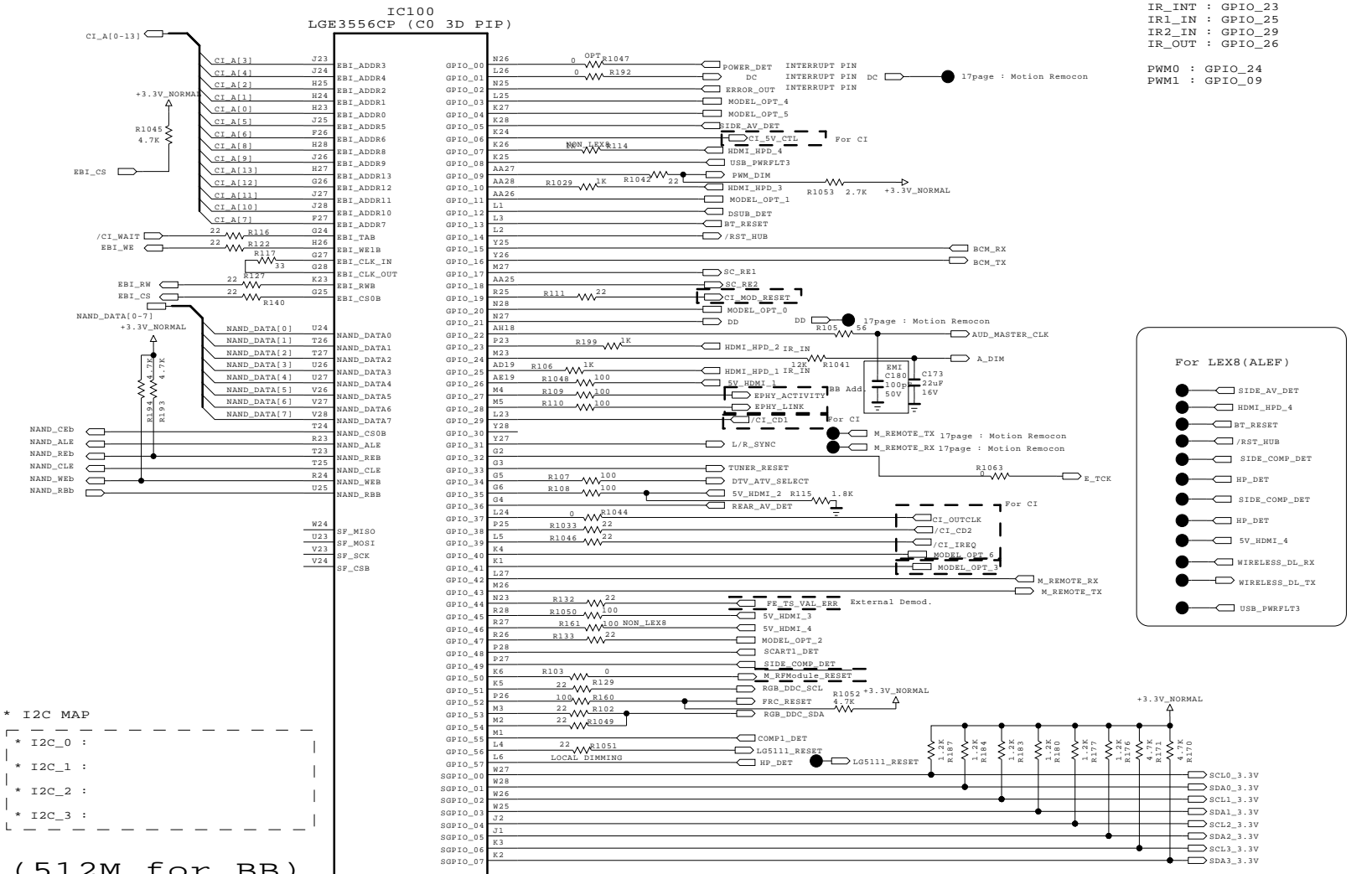

MODEL OPTION

PIN NAME	PIN NO.	HIGH	LOW
MODEL_OPT_0	N28	URSA3	NOM_URSA3
MODEL_OPT_1	AA26	MAIN_MINI_LVDS	MAIN_LVDS
MODEL_OPT_2	R26	DDR-512M	DDR-236M
MODEL_OPT_3	K1	PHD	HD
MODEL_OPT_4	L25	FRC	NOM_FRC
MODEL_OPT_5	K27	GIP	NOM-GIP
MODEL_OPT_6	K4	OLED	NOM_OLED

*MODEL_OPT_0 & MODEL_OPT_4 REFER TO THIS OPTION

MODEL_OPT_0	MODEL_OPT_4
LOW	LOW
HIGH	LOW
HIGH	HIGH
LOW	HIGH

For LEX8 (ALEF)

	CHINA	EU
MODEL_OPT_3	43page:/BT_ON_OFF	
MODEL_OPT_4	15page:/TW_9910_RESET	26page:/USB_PWRON3
MODEL_OPT_5	15page:/CHB_RESET	

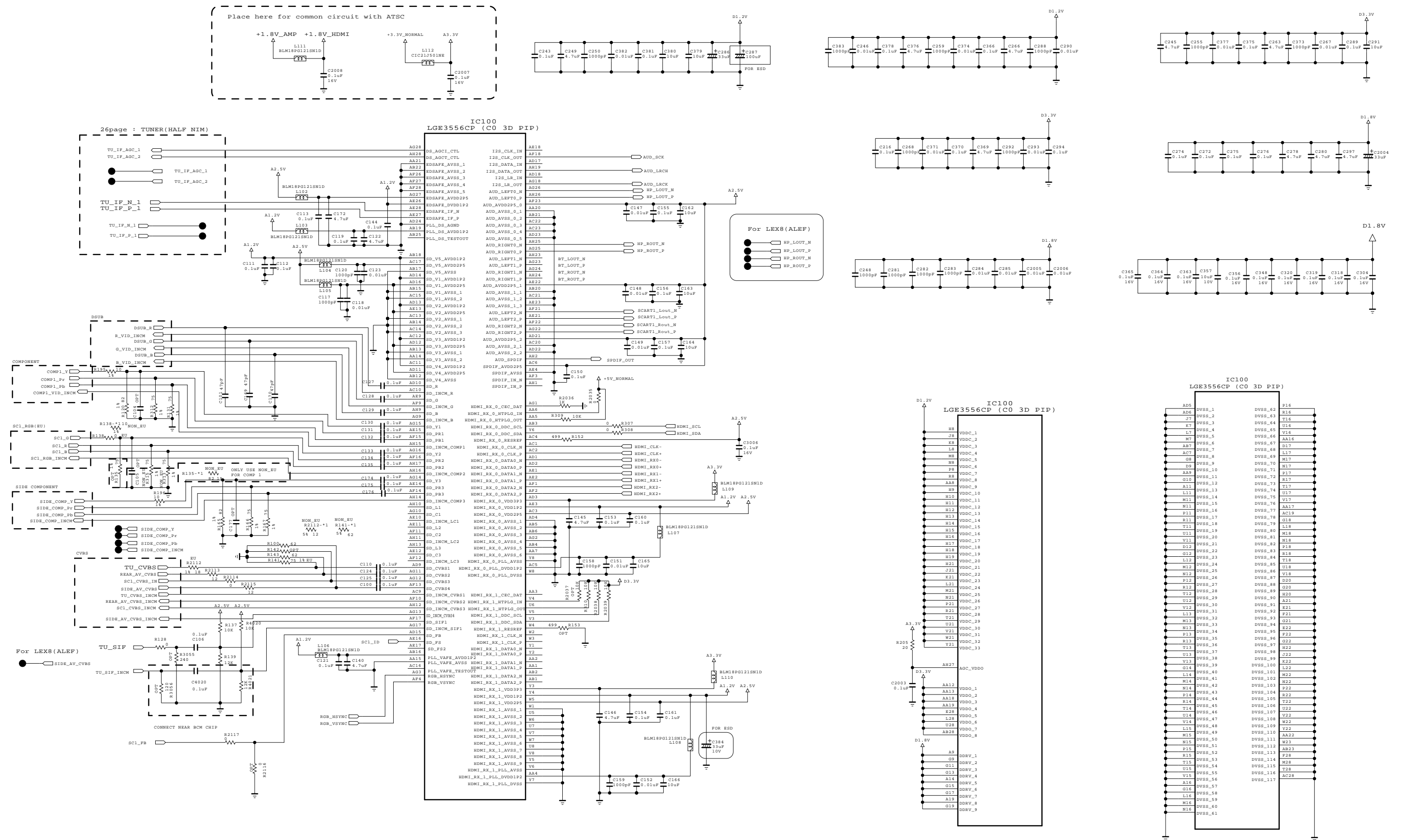

THE Δ SYMBOL MARK OF THIS SCHEMATIC DIAGRAM INCORPORATES SPECIAL FEATURES IMPORTANT FOR PROTECTION FROM X-RADIATION. FILRE AND ELECTRICAL SHOCK HAZARDS, WHEN SERVICING IF IS ESSENTIAL THAT ONLY MANUFACTURES SPECIFIED PARTS BE USED FOR THE CRITICAL COMPONENTS IN THE Δ SYMBOL MARK OF THE SCHEMATIC.

SECRET
LGElectronics



MODEL	EUROBTV	DATE	2009.06.18
BLOCK	BCM3556 VIDEO IN	SHEET	3

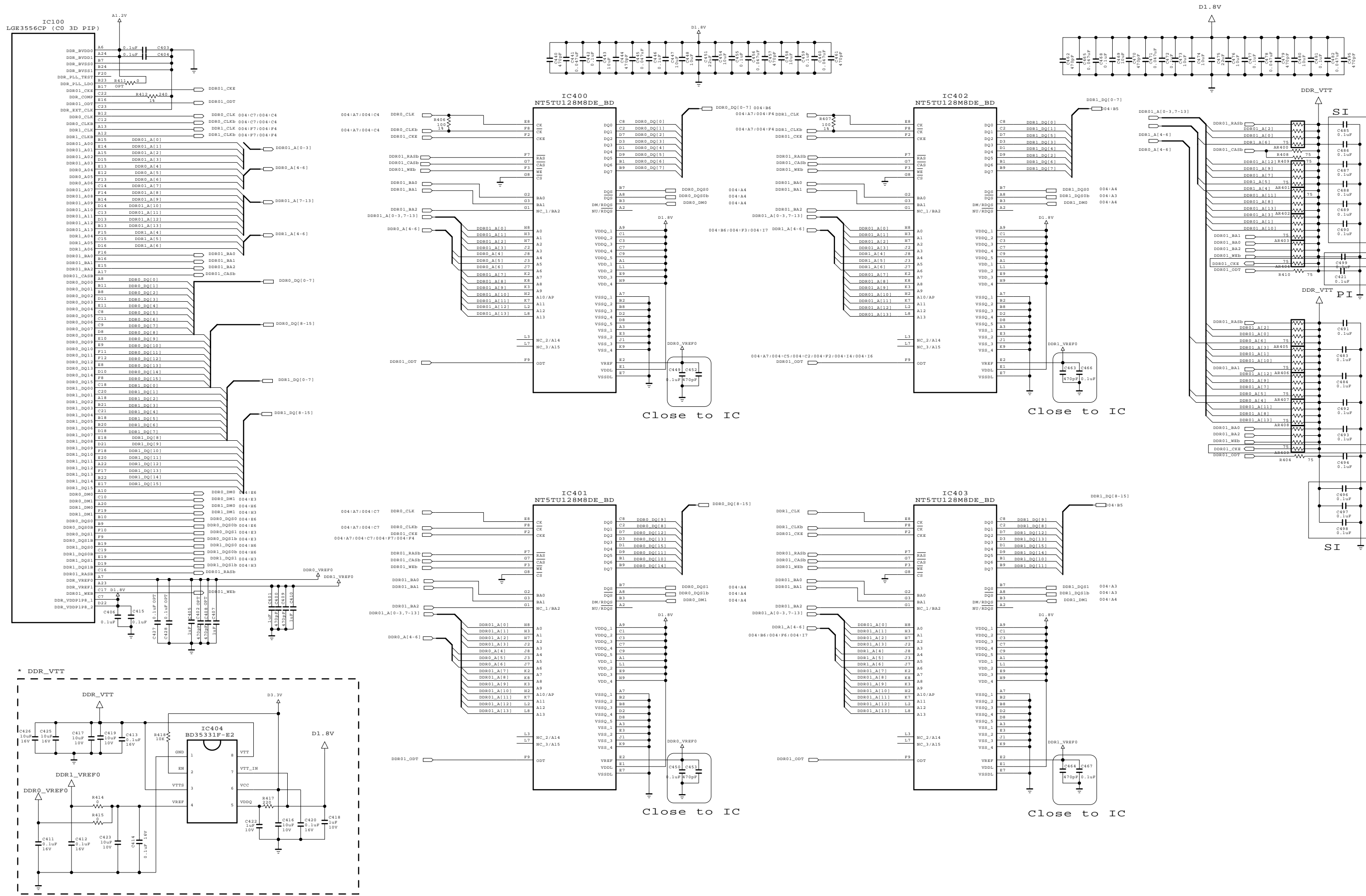

THE SYMBOL MARK OF THIS SCHEMATIC DIAGRAM INCORPORATES SPECIAL FEATURES IMPORTANT FOR PROTECTION FROM X-RADIATION. FILRE AND ELECTRICAL SHOCK HAZARDS, WHEN SERVICING IF IS ESSENTIAL THAT ONLY MANUFACTURERS SPECIFIED PARTS BE USED FOR THE CRITICAL COMPONENTS IN THE SYMBOL MARK OF THE SCHEMATIC.

SECRET
LGElectronics

HONG YEON HYUK



MODEL	BCM (EUROBBTV)	DATE	2009.06.18
BLOCK	DDR Memory	SHEET	4

EARPHONE BLOCK - spec out

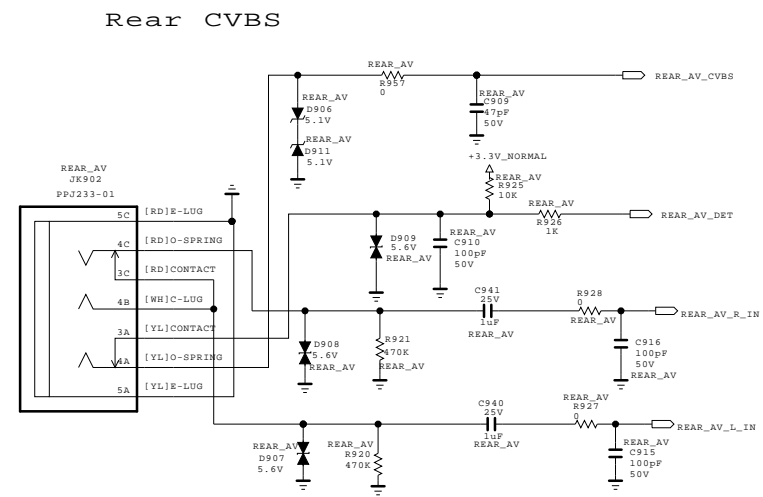
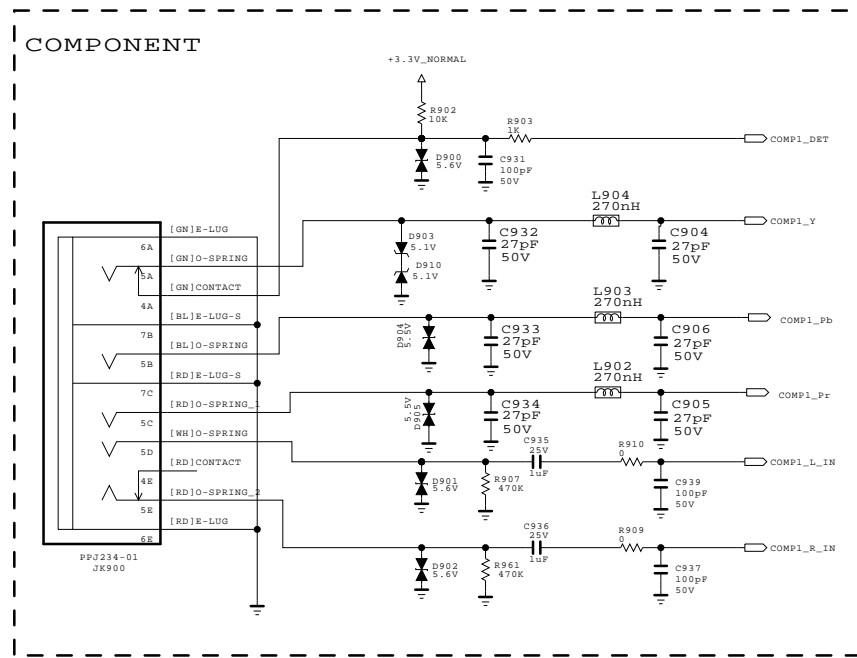

THE SYMBOL MARK OF THIS SCHEMATIC DIAGRAM INCORPORATES SPECIAL FEATURES IMPORTANT FOR PROTECTION FROM X-RADIATION. FILRE AND ELECTRICAL SHOCK HAZARDS, WHEN SERVICING IF IS ESSENTIAL THAT ONLY MANUFACTURES SPECIFIED PARTS BE USED FOR THE CRITICAL COMPONENTS IN THE SYMBOL MARK OF THE SCHEMATIC.

SECRET
LGElectronics

LG ELECTRONICS

MODEL	EUROBBTV	DATE	2009.06.18
BLOCK	ETC SUB BOARD I/F	SHEET	9 /

Motion Remote controller

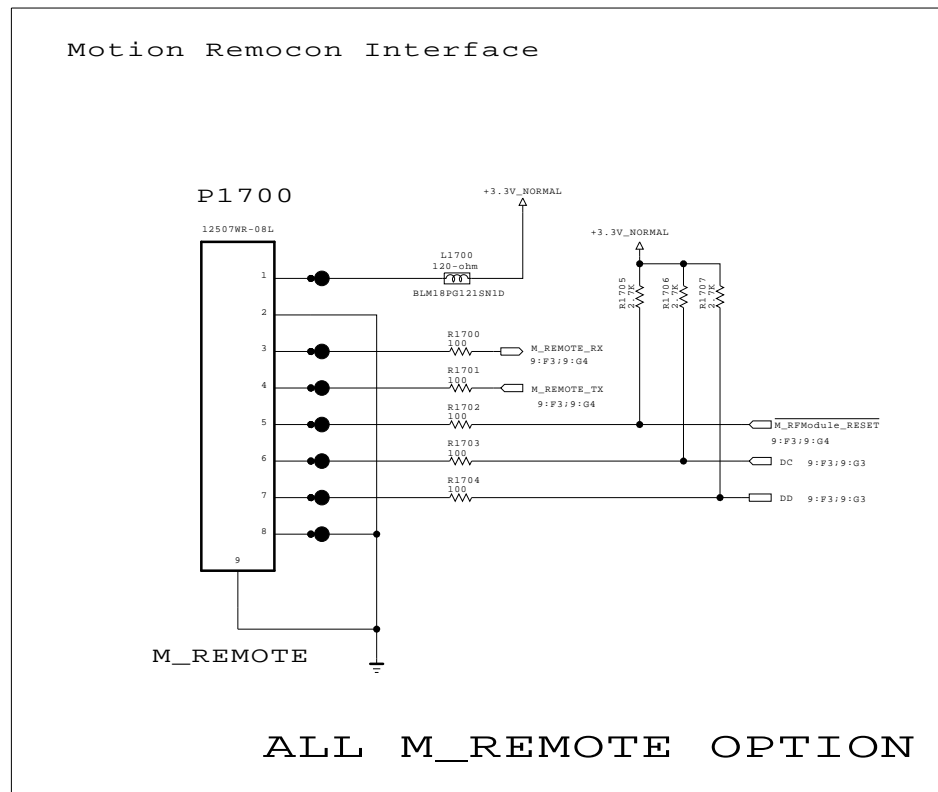

THE SYMBOL MARK OF THIS SCHEMATIC DIAGRAM INCORPORATES SPECIAL FEATURES IMPORTANT FOR PROTECTION FROM X-RADIATION. FILRE AND ELECTRICAL SHOCK HAZARDS, WHEN SERVICING IF IS ESSENTIAL THAT ONLY MANUFACTURES SPECIFIED PARTS BE USED FOR THE CRITICAL COMPONENTS IN THE SYMBOL MARK OF THE SCHEMATIC.

SECRET
LGElectronics



MODEL	GP2_BCM_ATSC	DATE	09/10/xx
BLOCK	MOTION_REMOCO	SHEET	20 / 100

Sub AMP.

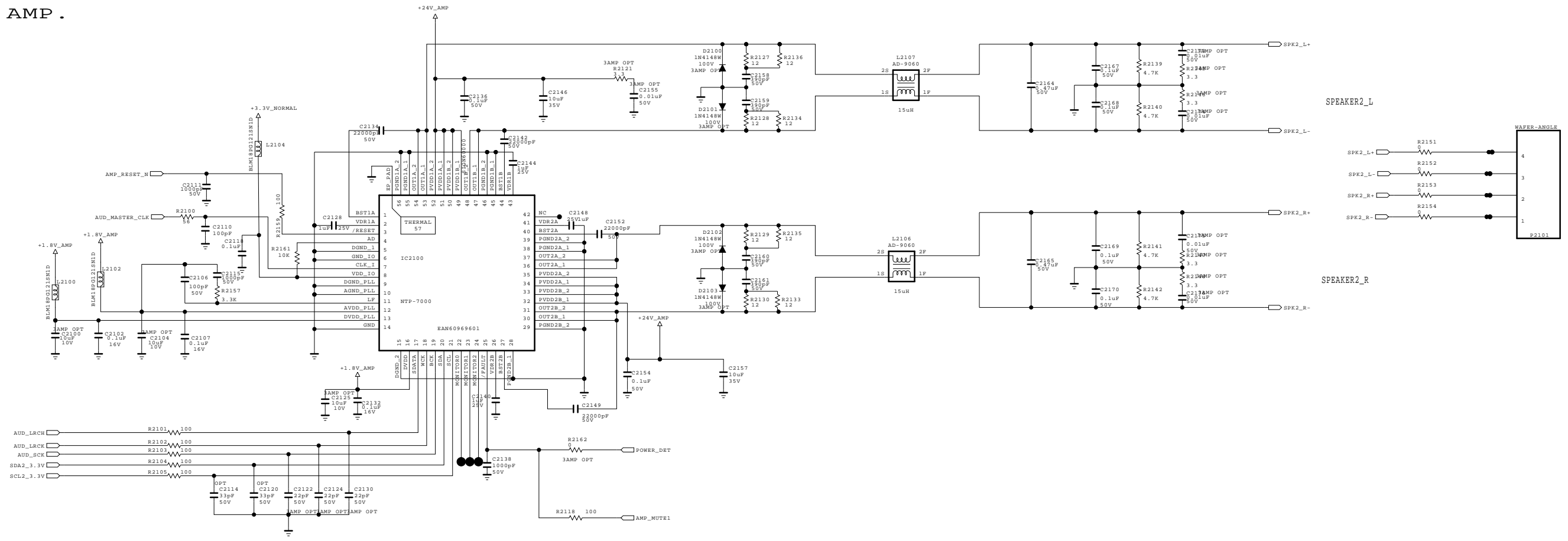

Woofers AMP.

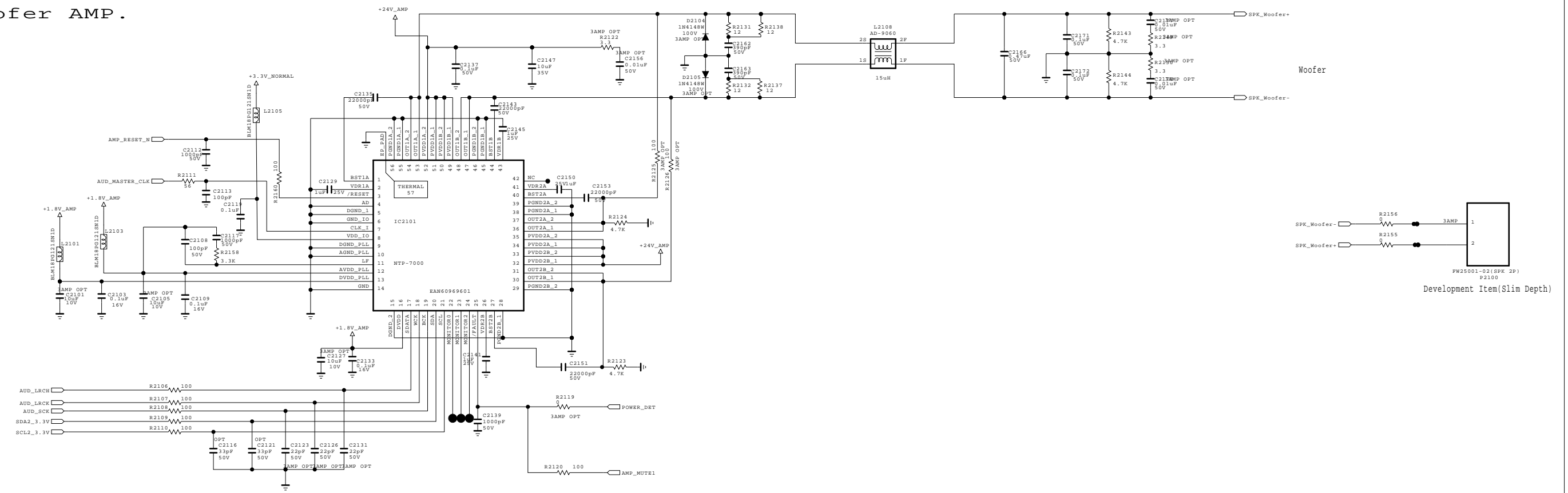

THE Δ SYMBOL MARK OF THIS SCHEMATIC DIAGRAM INCORPORATES SPECIAL FEATURES IMPORTANT FOR PROTECTION FROM X-RADIATION. FILRE AND ELECTRICAL SHOCK HAZARDS, WHEN SERVICING IF IS ESSENTIAL THAT ONLY MANUFACTURES SPECIFIED PARTS BE USED FOR THE CRITICAL COMPONENTS IN THE Δ SYMBOL MARK OF THE SCHEMATIC.

SECRET
LGElectronics



MODEL	GP2_BCM_ATSC	DATE	09.10
BLOCK	AMP_SUB_NTP	SHEET	21 / 100

LG LOGO FOR LE9500

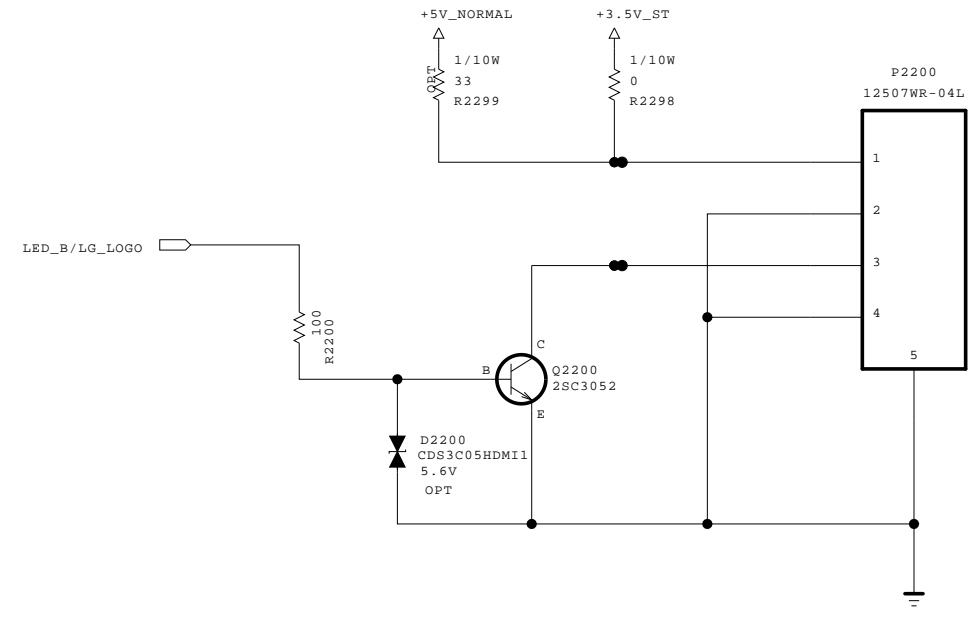

THE ⚠ SYMBOL MARK OF THIS SCHEMATIC DIAGRAM INCORPORATES SPECIAL FEATURES IMPORTANT FOR PROTECTION FROM X-RADIATION. FILRE AND ELECTRICAL SHOCK HAZARDS, WHEN SERVICING IF IS ESSENTIAL THAT ONLY MANUFACTURES SPECIFIED PARTS BE USED FOR THE CRITICAL COMPONENTS IN THE ⚠ SYMBOL MARK OF THE SCHEMATIC.

SECRET	 LG ELECTRONICS
LGElectronics	

MODEL	GP2_BCM_ATSC	DATE	09/10/xx
BLOCK	LG_LOGO_LE9500	SHEET	22 / 100

SIDE IR Emitter sync USB JACK

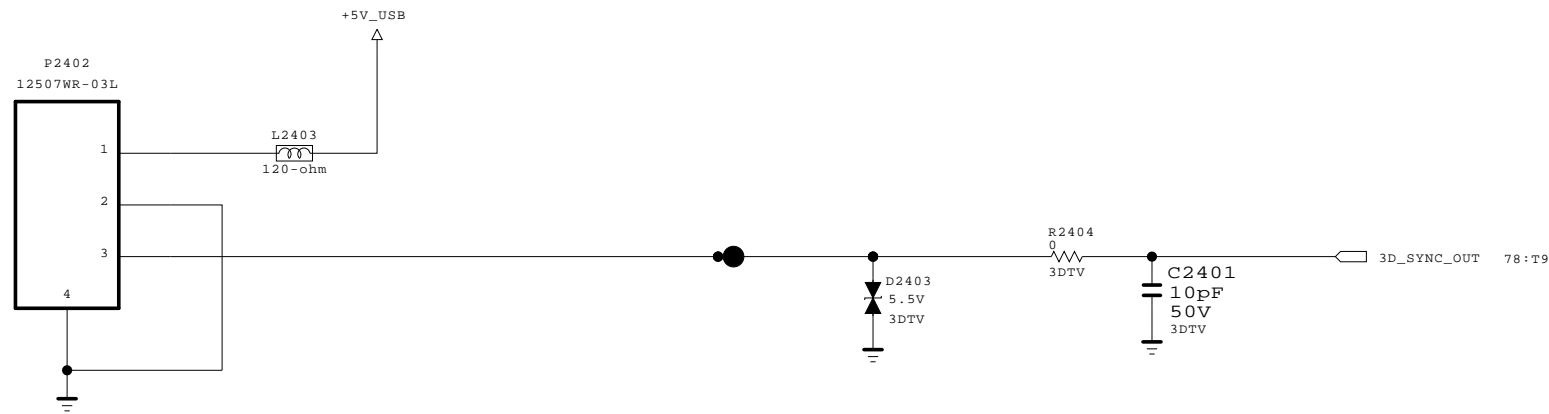

THE ⚠ SYMBOL MARK OF THIS SCHEMATIC DIAGRAM INCORPORATES SPECIAL FEATURES IMPORTANT FOR PROTECTION FROM X-RADIATION. FILRE AND ELECTRICAL SHOCK HAZARDS, WHEN SERVICING IF IS ESSENTIAL THAT ONLY MANUFACTURES SPECIFIED PARTS BE USED FOR THE CRITICAL COMPONENTS IN THE ⚠ SYMBOL MARK OF THE SCHEMATIC.

SECRET	 LG ELECTRONICS
LGElectronics	

MODEL	GP2_BCM_ATSC	DATE	09/11/18
BLOCK	3D_IR_GENDER	SHEET	24 / 100

CAN H-NIM/NIM TUNER for EU

TU2701-1
TDFR-G155D

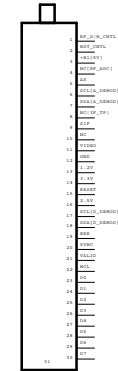

TU2701-2
TDFR-G155D

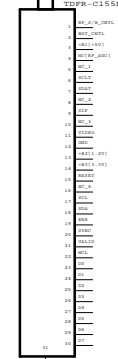

TU2701-3
TDFR-G155D

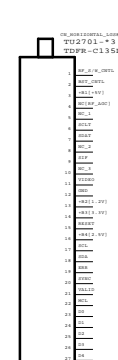

TU2701-4
TDFR-G055D

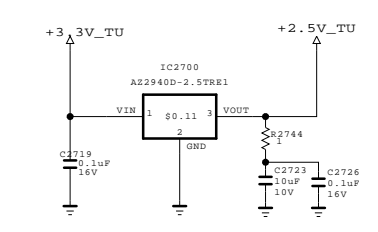
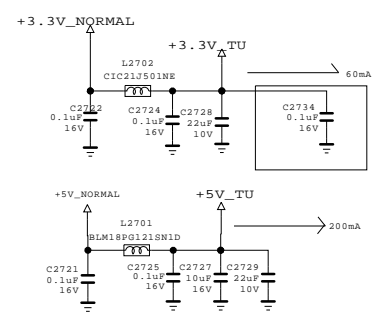
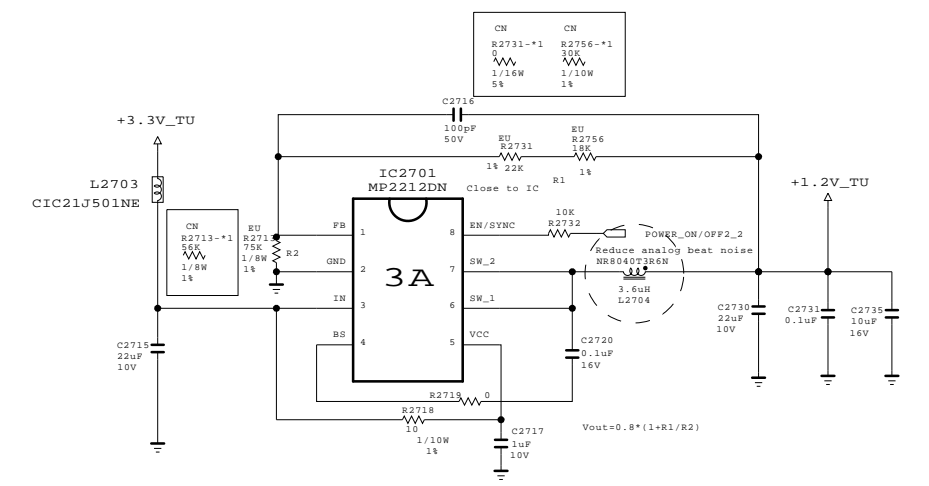
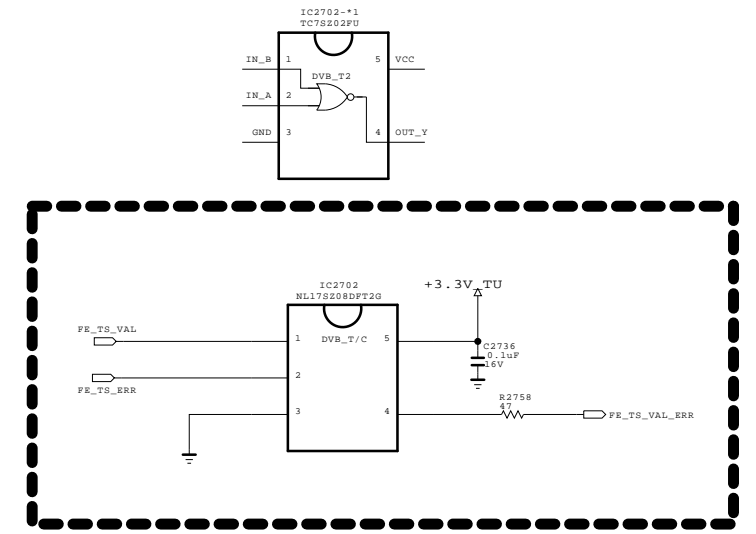
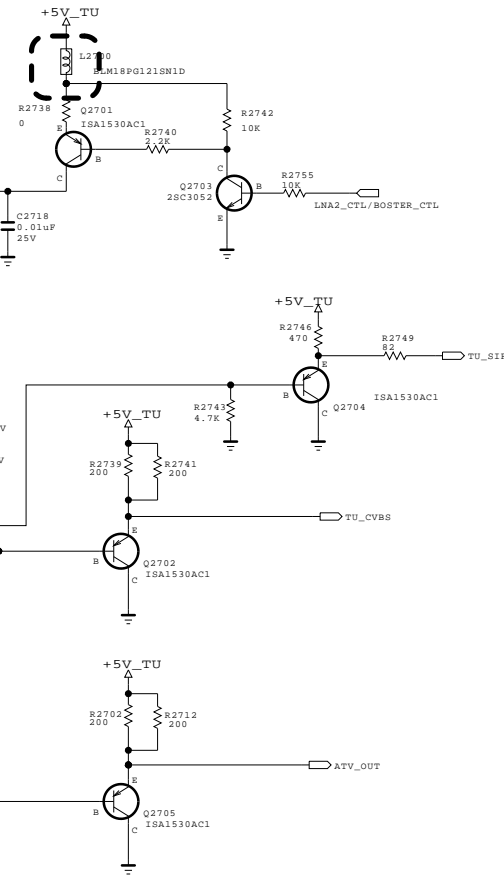
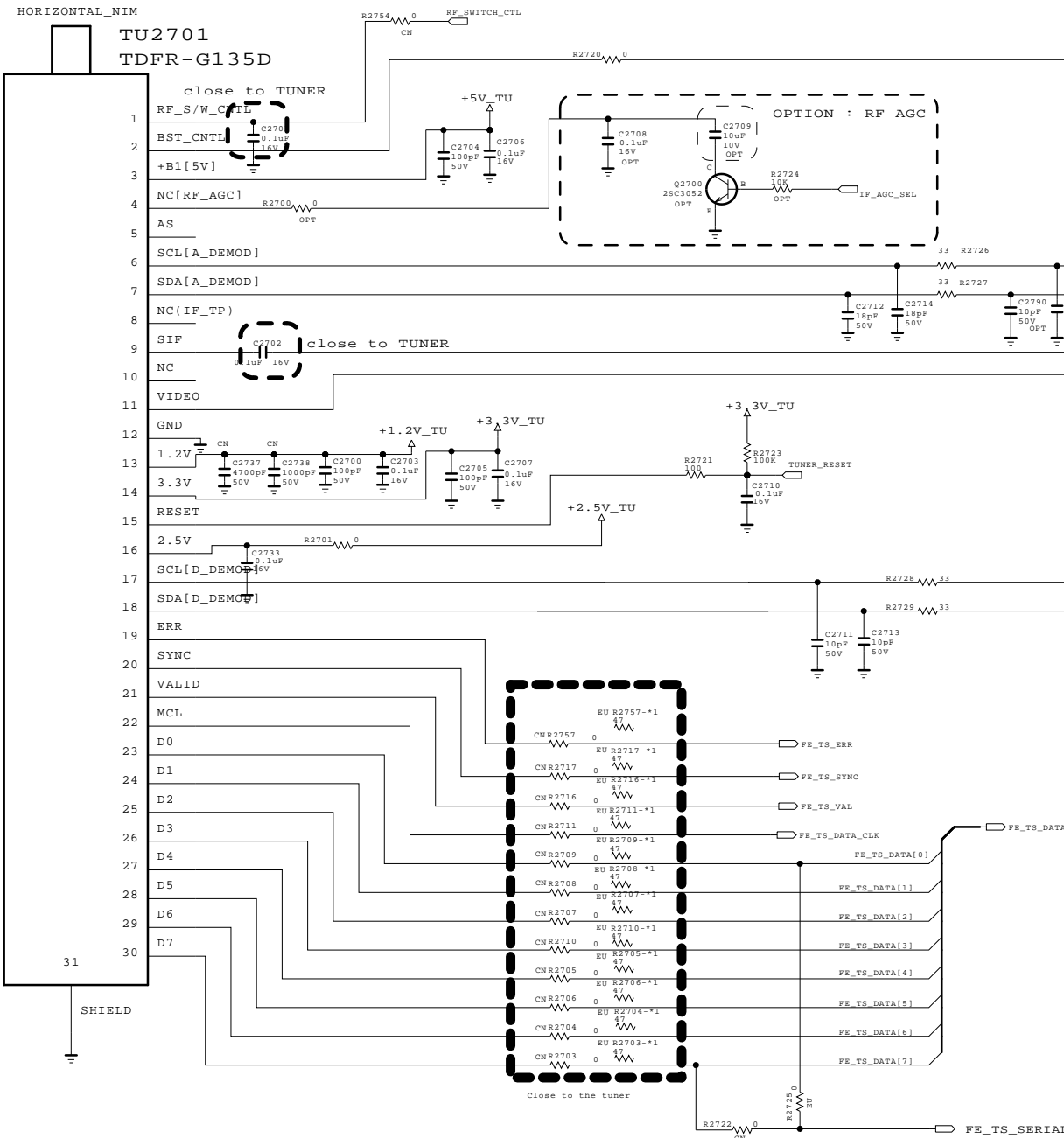
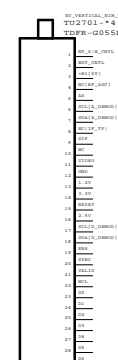

THE Δ SYMBOL MARK OF THIS SCHEMATIC DIAGRAM INCORPORATES SPECIAL FEATURES IMPORTANT FOR PROTECTION FROM X-RADIATION. FILRE AND ELECTRICAL SHOCK HAZARDS, WHEN SERVICING IF IS ESSENTIAL THAT ONLY MANUFACTURERS SPECIFIED PARTS BE USED FOR THE CRITICAL COMPONENTS IN THE Δ SYMBOL MARK OF THE SCHEMATIC.

SECRET
LGElectronics

LG ELECTRONICS

MODEL		DATE	
BLOCK		SHEET	27

USB2 OPTION

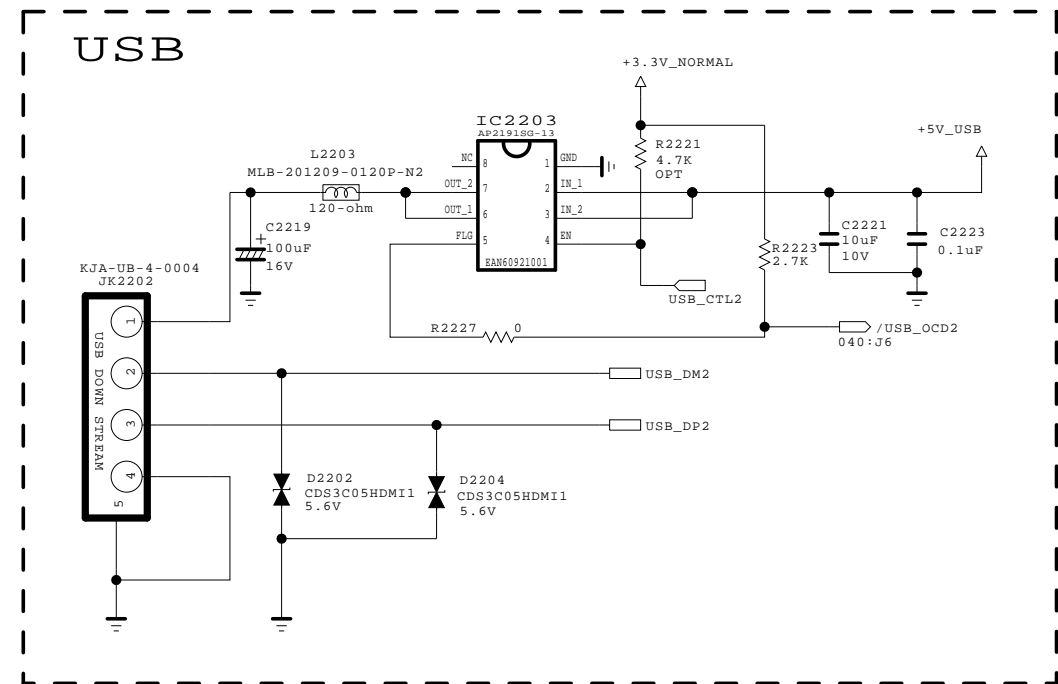
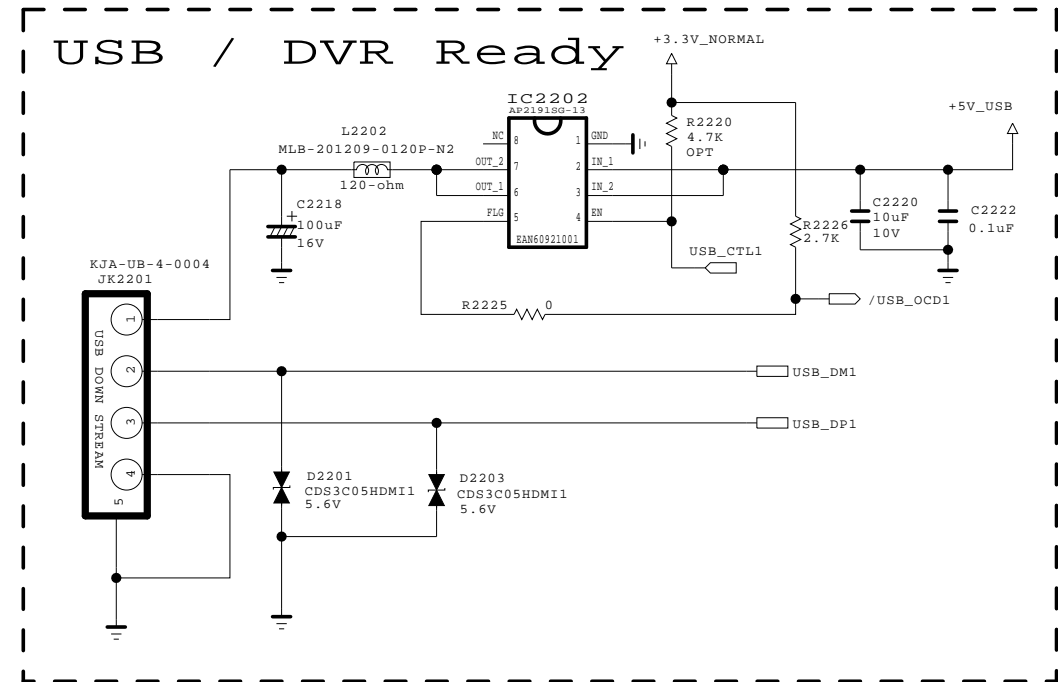
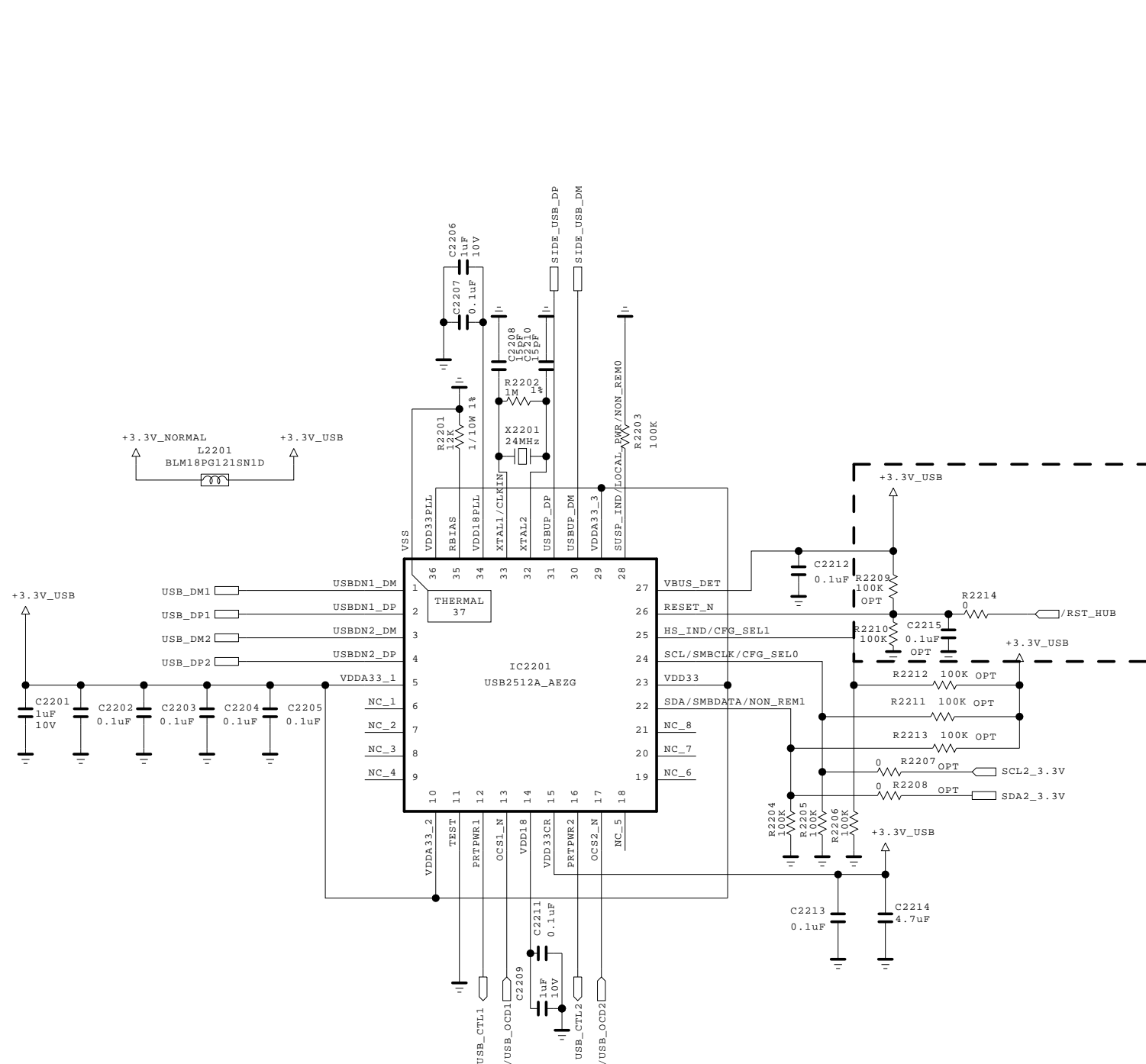

THE SYMBOL MARK OF THIS SCHEMATIC DIAGRAM INCORPORATES SPECIAL FEATURES IMPORTANT FOR PROTECTION FROM X-RADIATION. FILRE AND ELECTRICAL SHOCK HAZARDS, WHEN SERVICING IF IS ESSENTIAL THAT ONLY MANUFACTURES SPECIFIED PARTS BE USED FOR THE CRITICAL COMPONENTS IN THE SYMBOL MARK OF THE SCHEMATIC.

SECRET	LG ELECTRONICS
LGElectronics	

MODEL		DATE	
BLOCK		SHEET	40 /

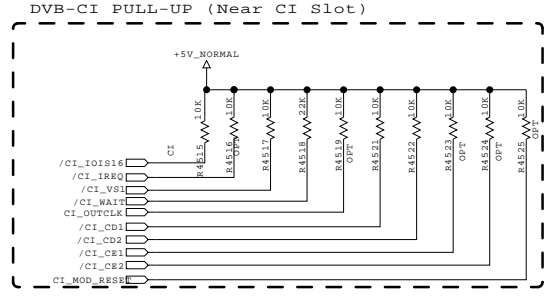
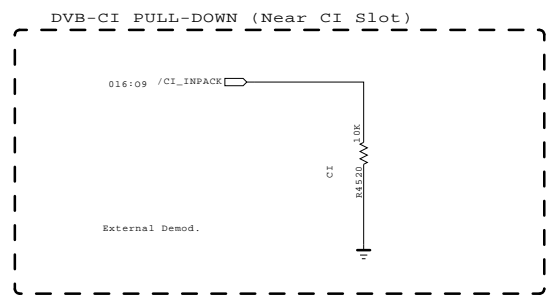
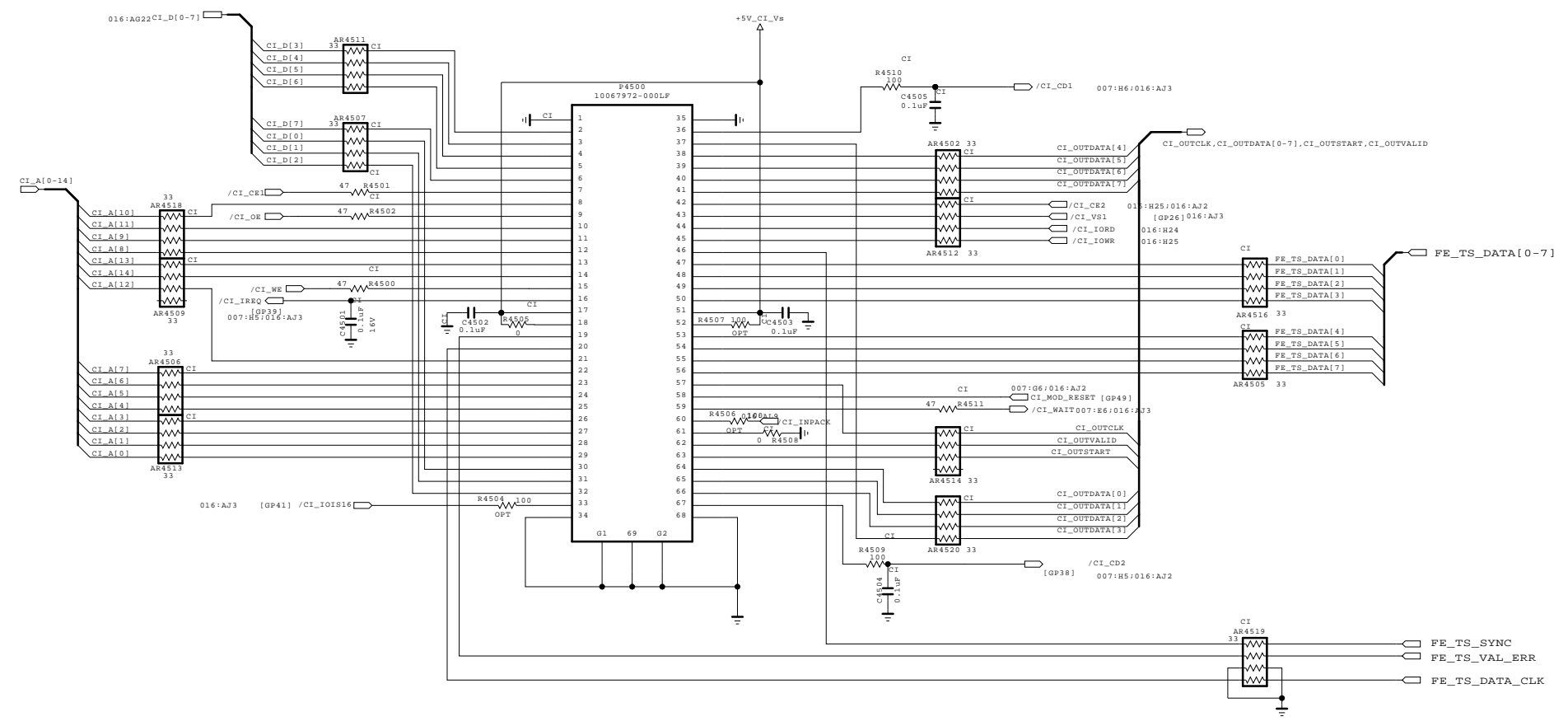
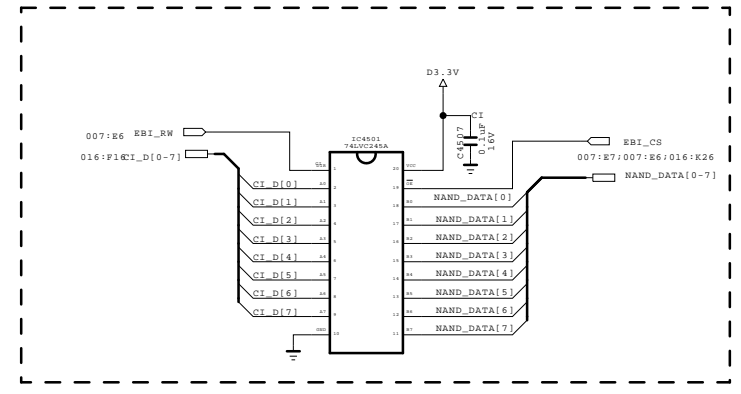
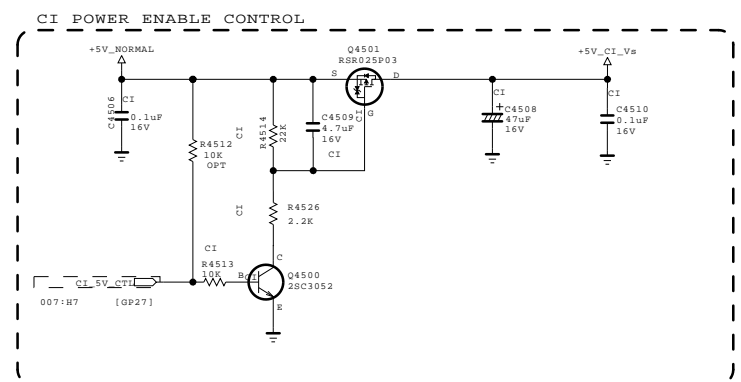
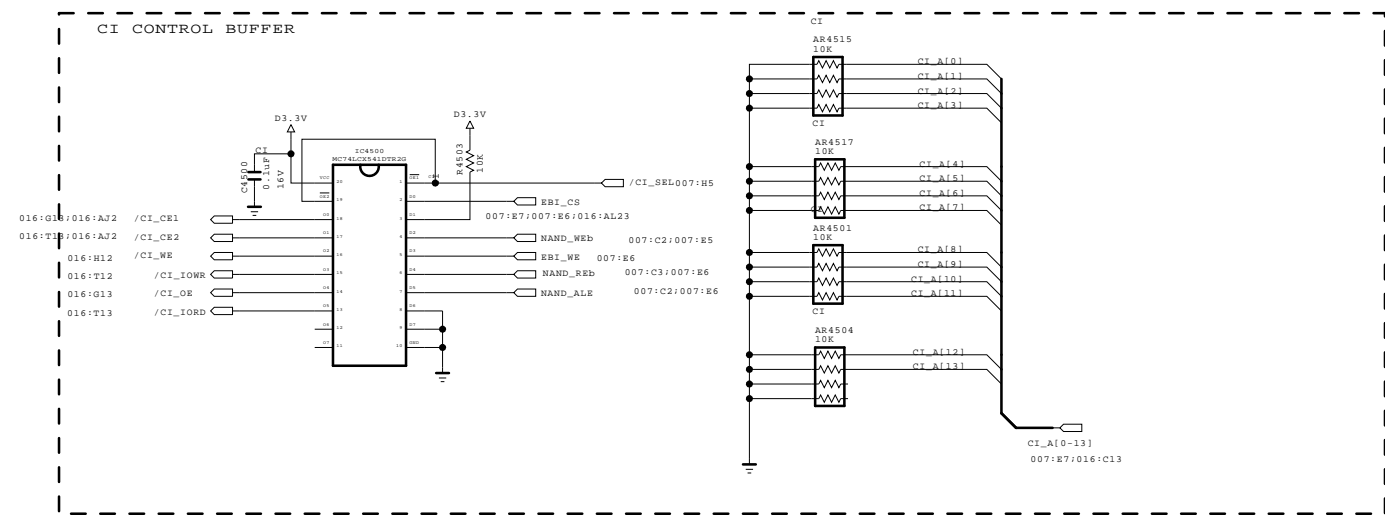

THE Δ SYMBOL MARK OF THIS SCHEMATIC DIAGRAM INCORPORATES SPECIAL FEATURES IMPORTANT FOR PROTECTION FROM X-RADIATION. FILRE AND ELECTRICAL SHOCK HAZARDS, WHEN SERVICING IF IS ESSENTIAL THAT ONLY MANUFACTURES SPECIFIED PARTS BE USED FOR THE CRITICAL COMPONENTS IN THE Δ SYMBOL MARK OF THE SCHEMATIC.

SECRET
LGElectronics



MODEL	EUROBBTV	DATE	2009.06.18
BLOCK	CI	SHEET	45 /

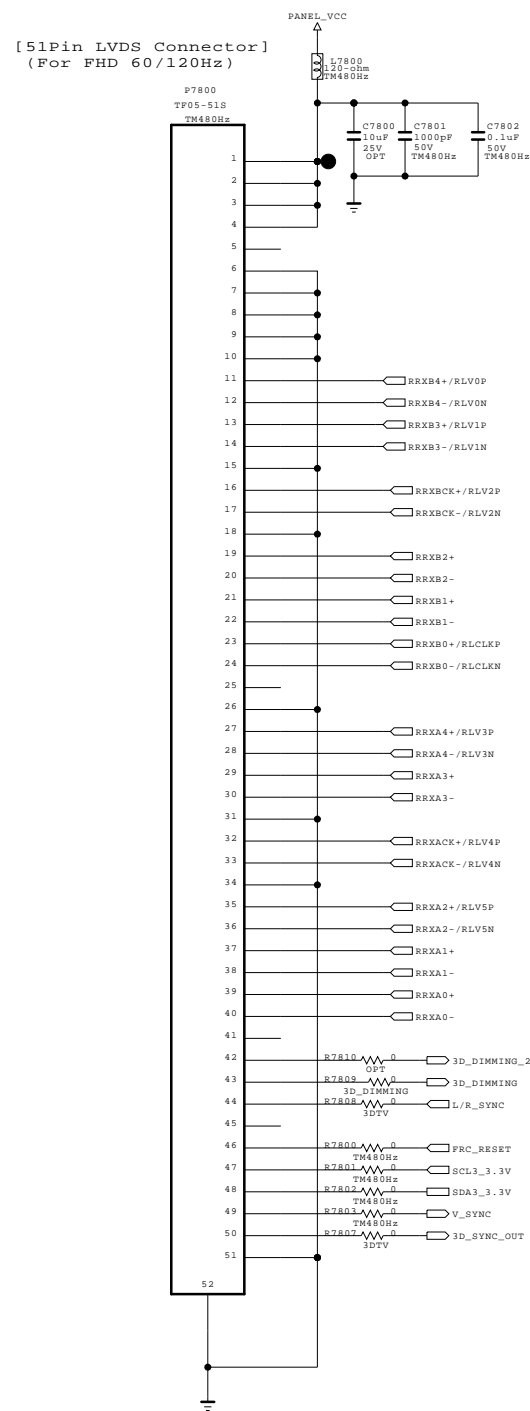

I2C_#3 Check(LG5111, LG1120, etc)
For Debugging

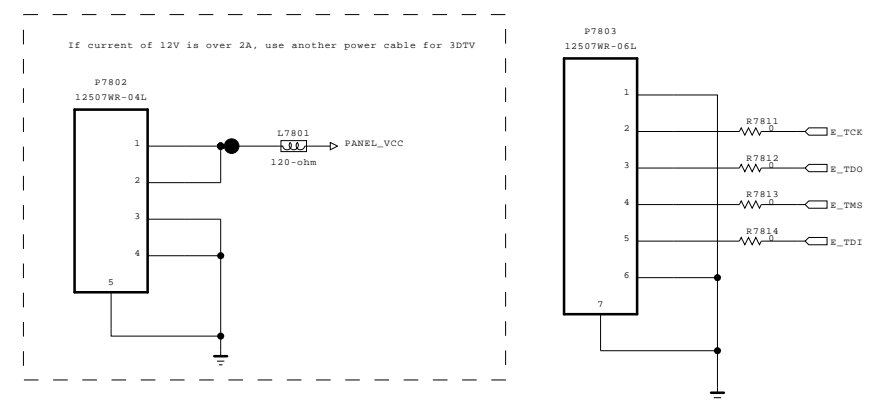
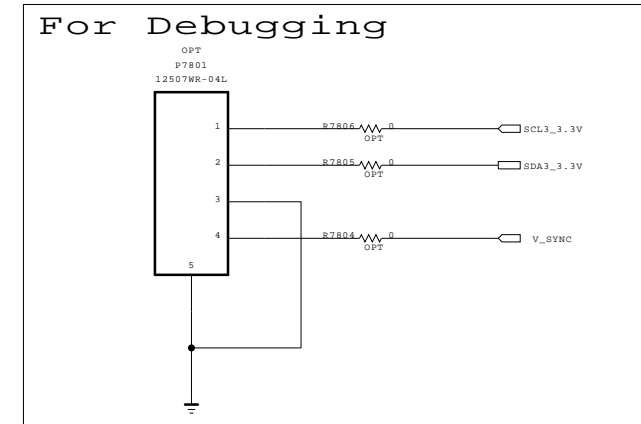

THE SYMBOL MARK OF THIS SCHEMATIC DIAGRAM INCORPORATES SPECIAL FEATURES IMPORTANT FOR PROTECTION FROM X-RADIATION. FILRE AND ELECTRICAL SHOCK HAZARDS, WHEN SERVICING IF IS ESSENTIAL THAT ONLY MANUFACTURES SPECIFIED PARTS BE USED FOR THE CRITICAL COMPONENTS IN THE SYMBOL MARK OF THE SCHEMATIC.

SECRET
LGElectronics

LG ELECTRONICS

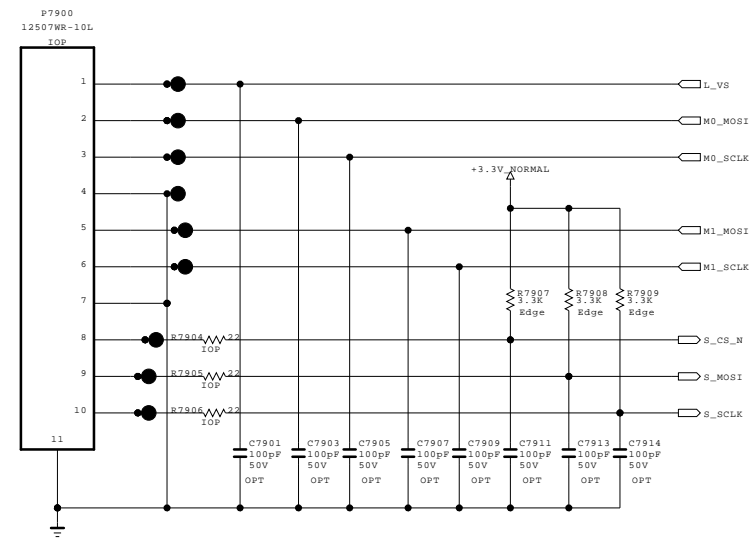

MODEL	COMMON	DATE	09/10/xx
BLOCK	LG5111 60Hz LVDS	SHEET	78 / 100

[To MASTER LED DRIVER]

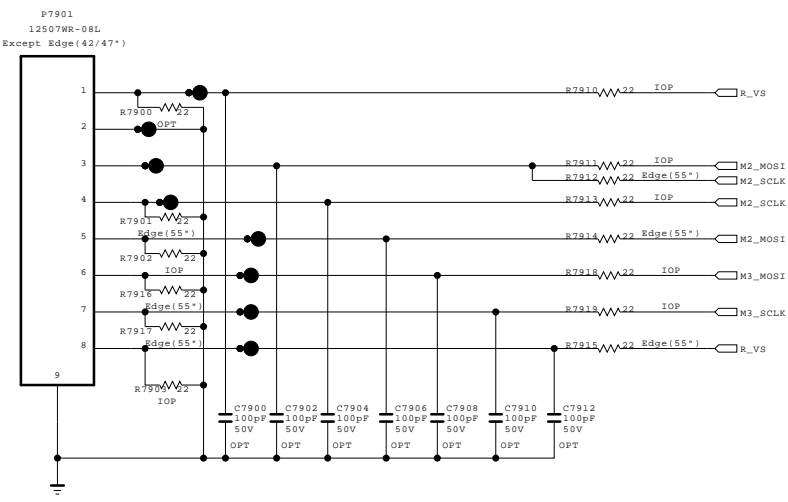

[To SLAVE LED DRIVER]



THE  SYMBOL MARK OF THIS SCHEMATIC DIAGRAM INCORPORATES SPECIAL FEATURES IMPORTANT FOR PROTECTION FROM X-RADIATION. FILRE AND ELECTRICAL SHOCK HAZARDS, WHEN SERVICING IF IS ESSENTIAL THAT ONLY MANUFACTURES SPECIFIED PARTS BE USED FOR THE CRITICAL COMPONENTS IN THE  SYMBOL MARK OF THE SCHEMATIC.

SECRET
LGElectronics



MODEL	GP2_Saturn7M	DATE	Ver. 1.0
BLOCK	Interface for LG5111	SHEET	72 /

FROM LIPS & POWER B/D

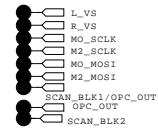
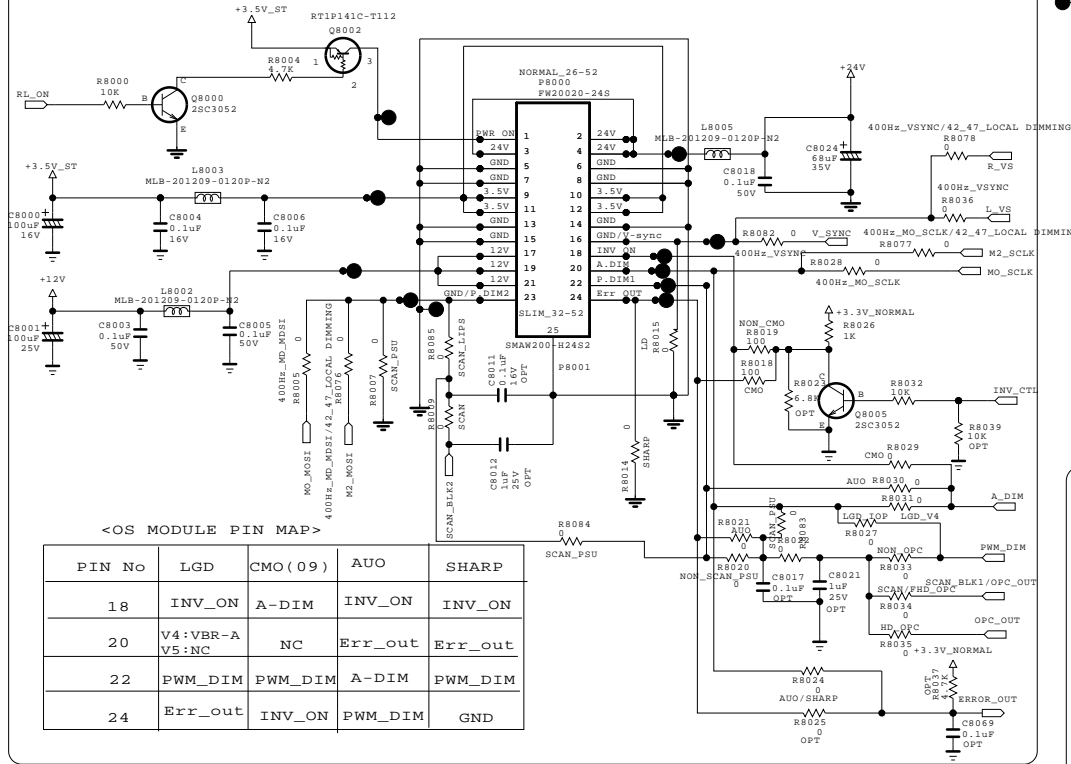

PIN No	LX95		
16	N.C		
18	Driver On		
22	N.C		
23	N.C		

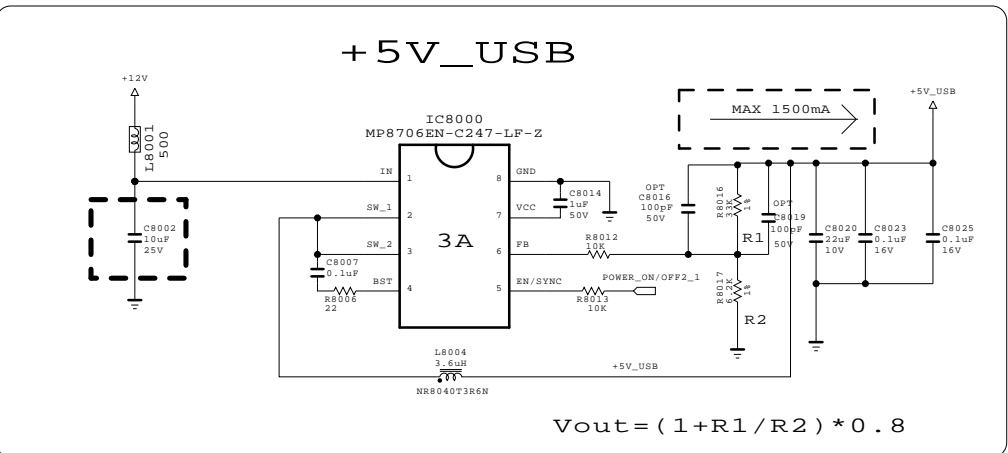
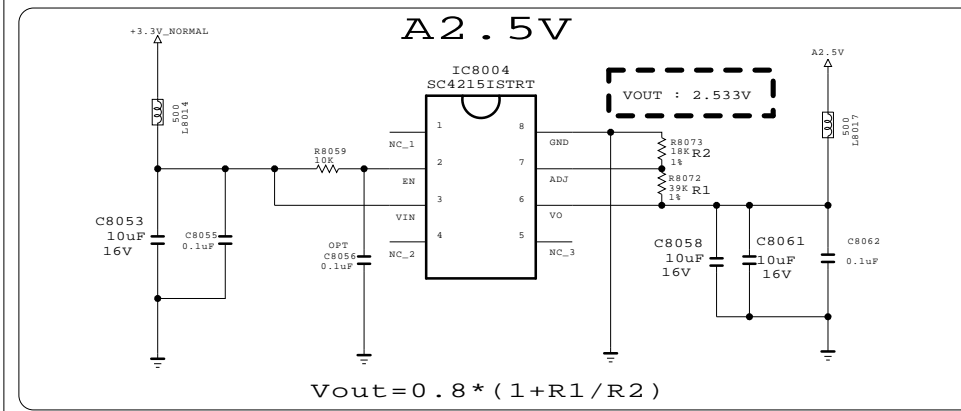
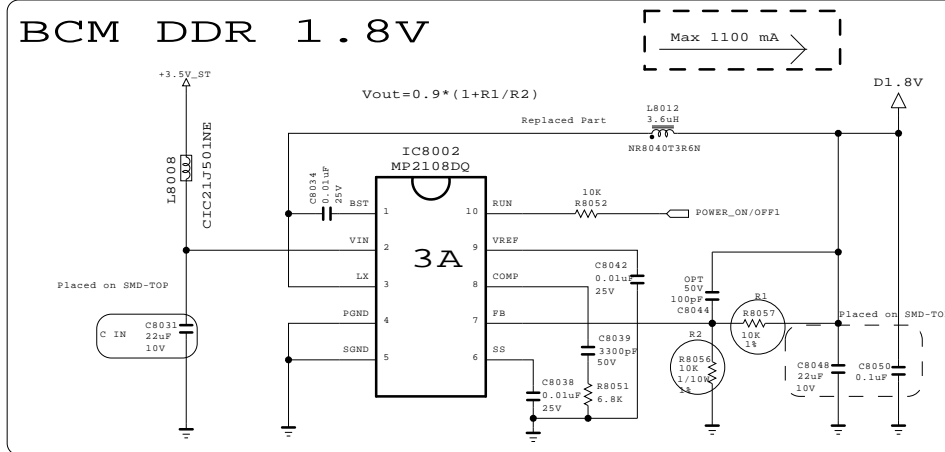
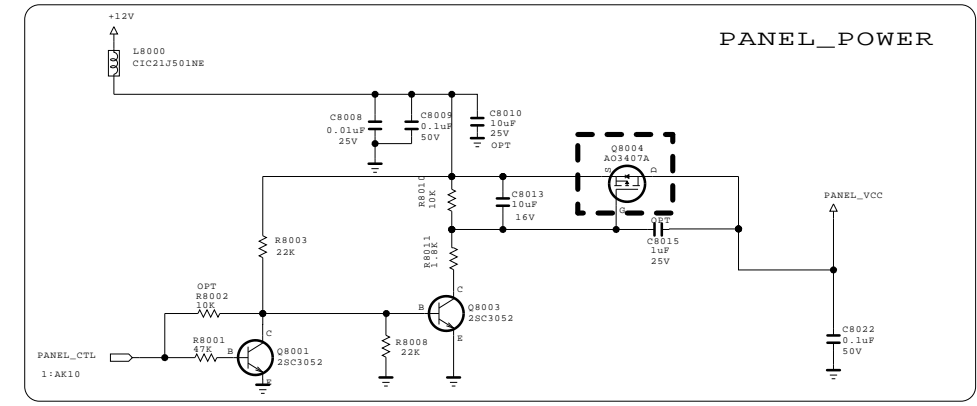
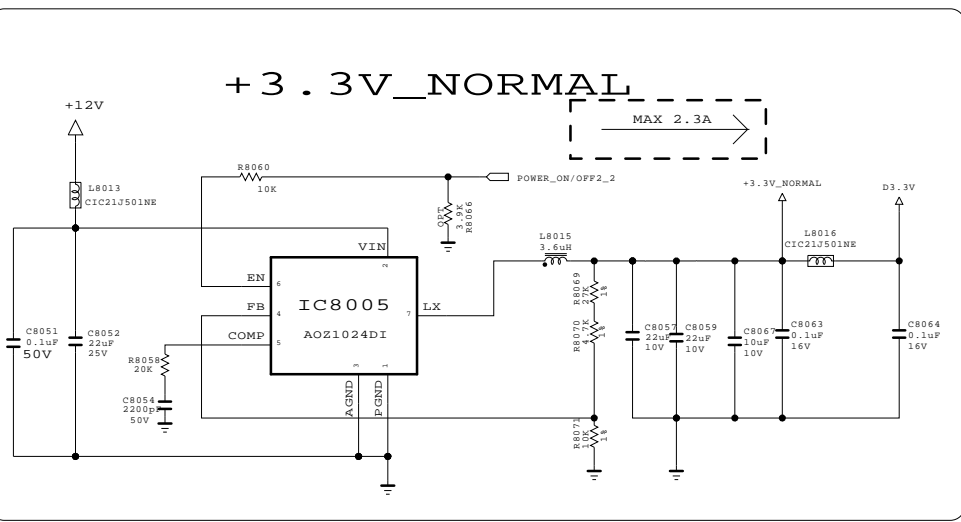
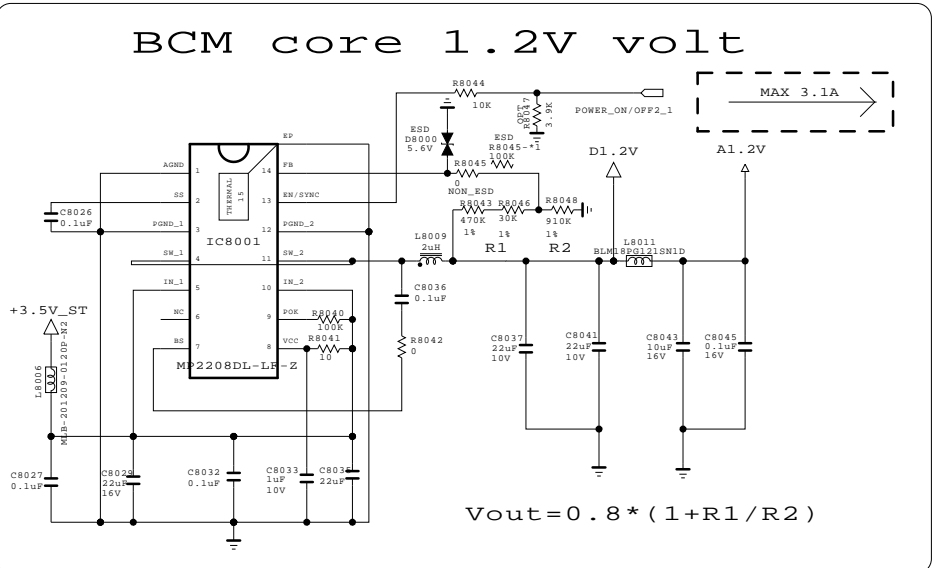
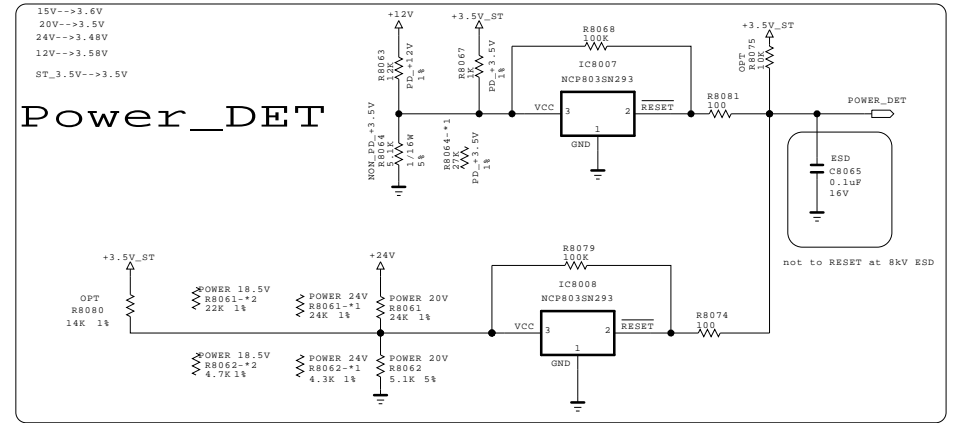
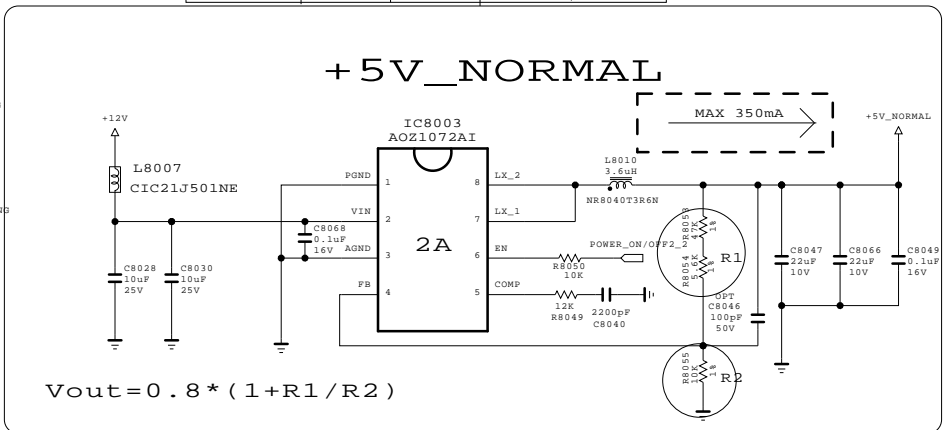

THE Δ SYMBOL MARK OF THIS SCHEMATIC DIAGRAM INCORPORATES SPECIAL FEATURES IMPORTANT FOR PROTECTION FROM X-RADIATION. FILRE AND ELECTRICAL SHOCK HAZARDS, WHEN SERVICING IF IS ESSENTIAL THAT ONLY MANUFACTURERS SPECIFIED PARTS BE USED FOR THE CRITICAL COMPONENTS IN THE Δ SYMBOL MARK OF THE SCHEMATIC.

SECRET
LGElectronics



MODEL	BCM (EUROBBTV)	DATE	
BLOCK	POWER	SHEET	15

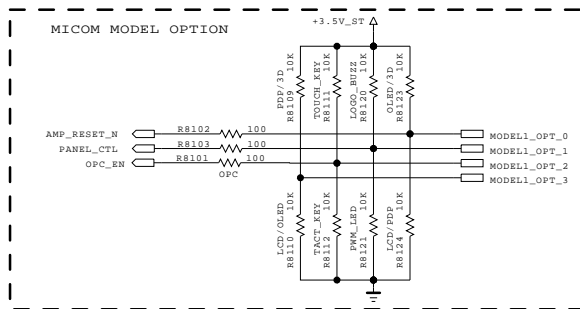
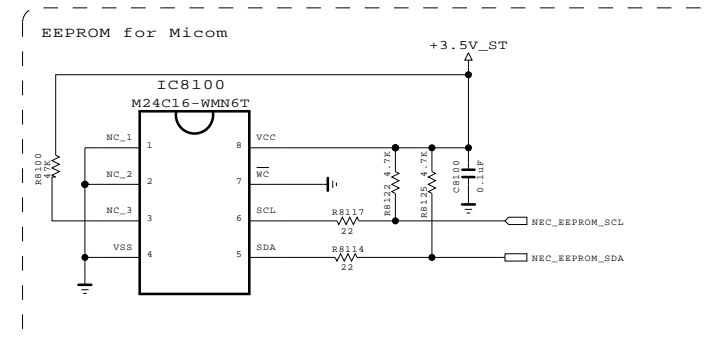
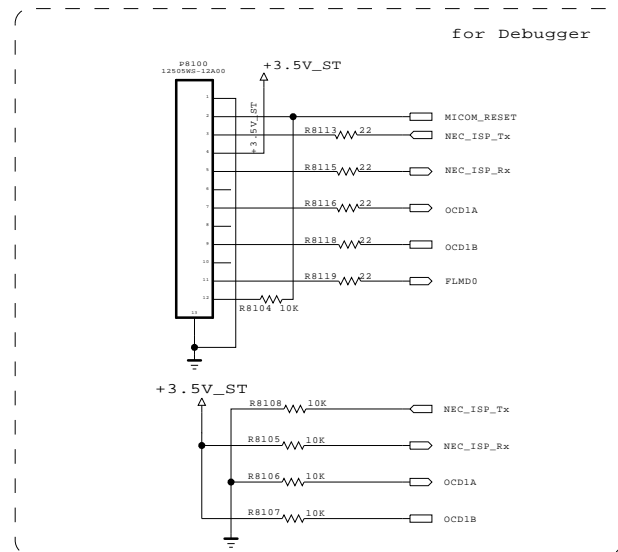

MODEL OPTION

PIN NAME	PIN NO.	HIGH	LOW
MODEL_OPT_0	8	OLED/3D	LCD/PDP
MODEL_OPT_1	11	LOGO_BUZZ	PWM_LED
MODEL_OPT_2	30	TOUCH_KEY	TACT_KEY
MODEL_OPT_3	31	PDP/3D	LCD/OLED

	LCD	PDP	OLED	3D
MODEL_OPT_0	0	0	1	1
MODEL_OPT_3	0	1	0	1

	LOW	LOW_SMALL	LX9500	HIGH
MODEL_OPT_1	0	0	1	1
MODEL_OPT_2	0	1	0	1

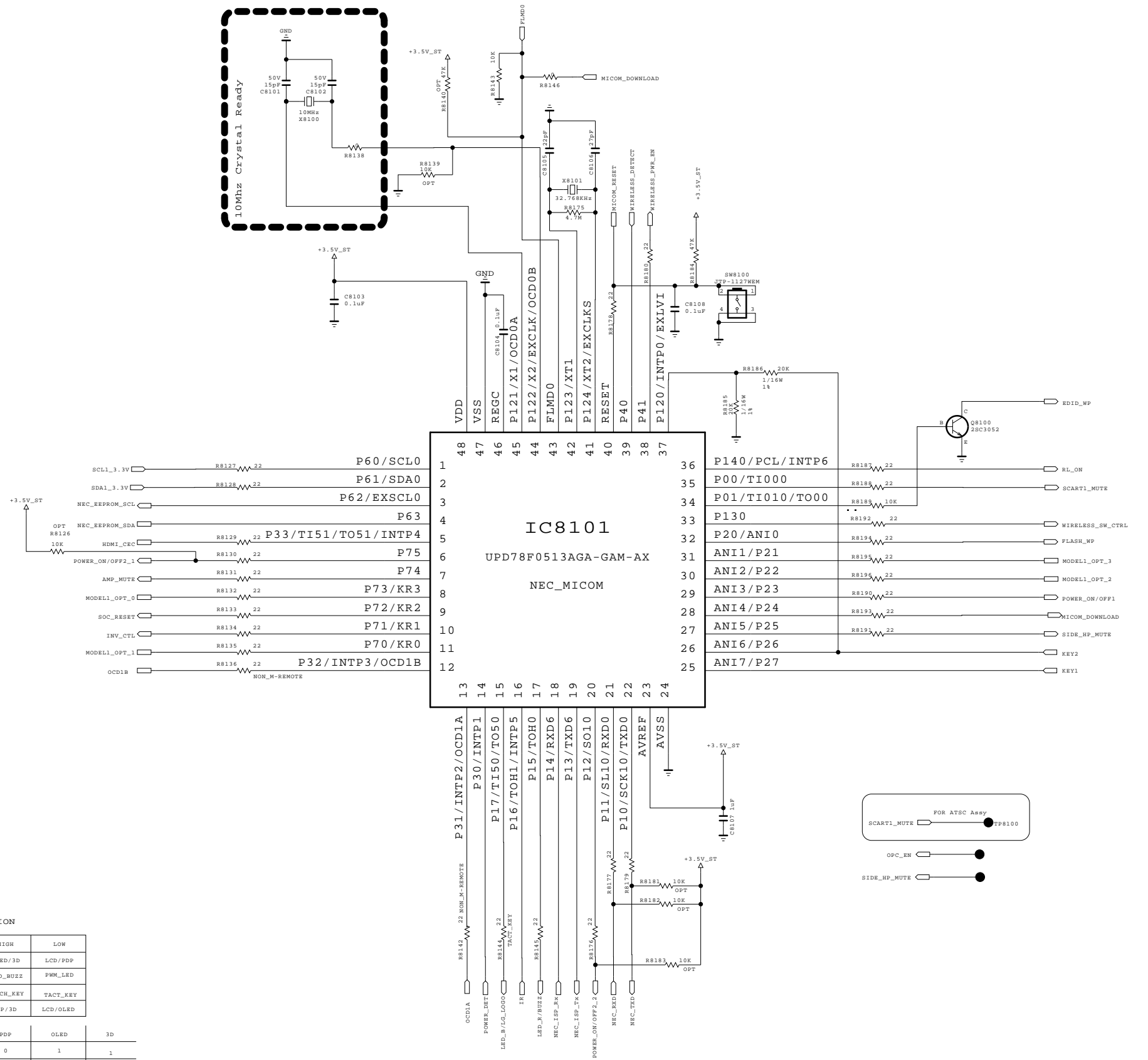

THE Δ SYMBOL MARK OF THIS SCHEMATIC DIAGRAM INCORPORATES SPECIAL FEATURES IMPORTANT FOR PROTECTION FROM X-RADIATION. FILRE AND ELECTRICAL SHOCK HAZARDS, WHEN SERVICING IF IS ESSENTIAL THAT ONLY MANUFACTURES SPECIFIED PARTS BE USED FOR THE CRITICAL COMPONENTS IN THE Δ SYMBOL MARK OF THE SCHEMATIC.

SECRET
LGElectronics

LG ELECTRONICS

MODEL	GP2_Saturn7M	DATE	Ver. 1.4
BLOCK	MICOM	SHEET	5

IR & KEY

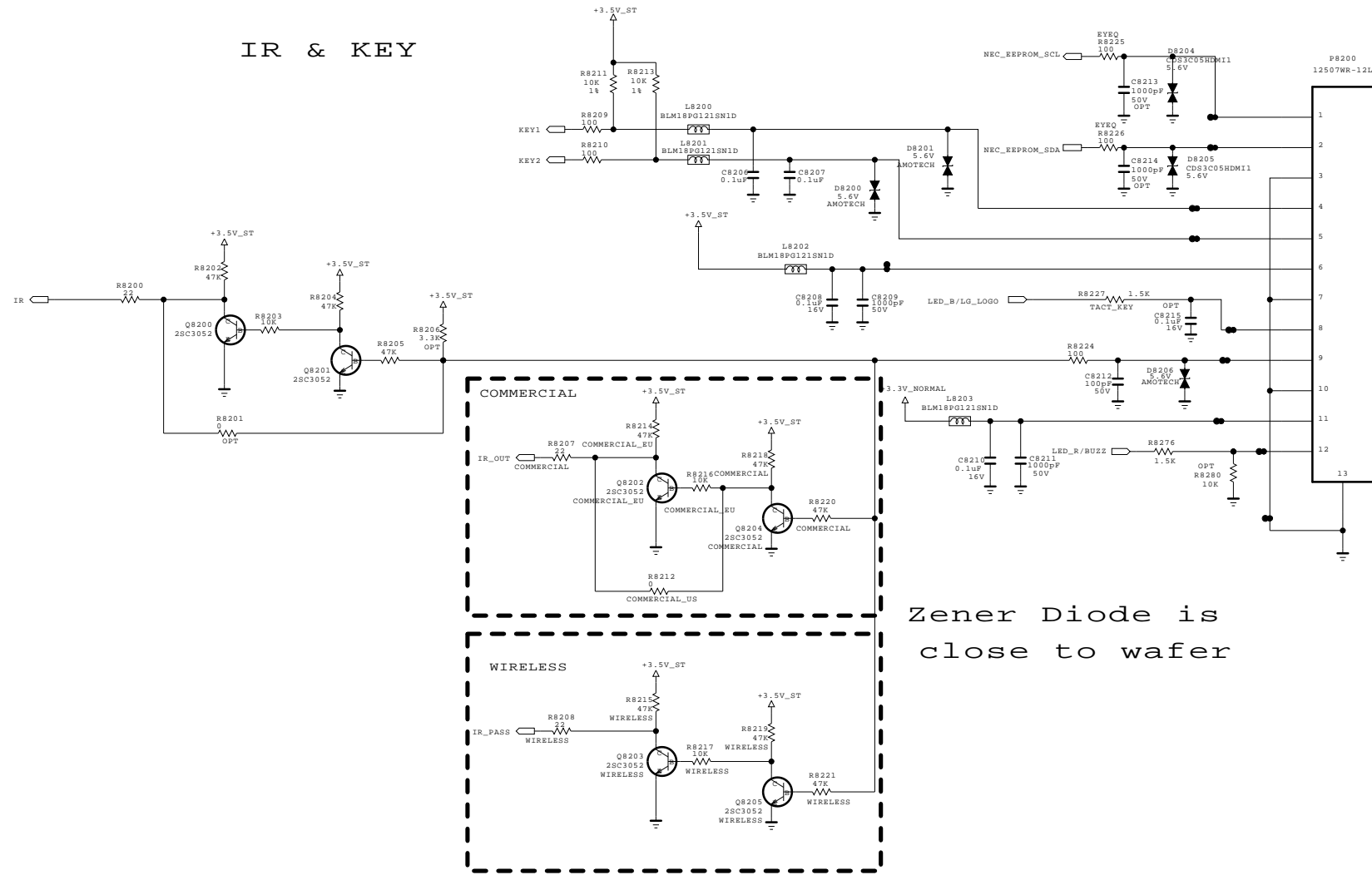

Zener Diode is close to wafer

ETHERNET CONNECT

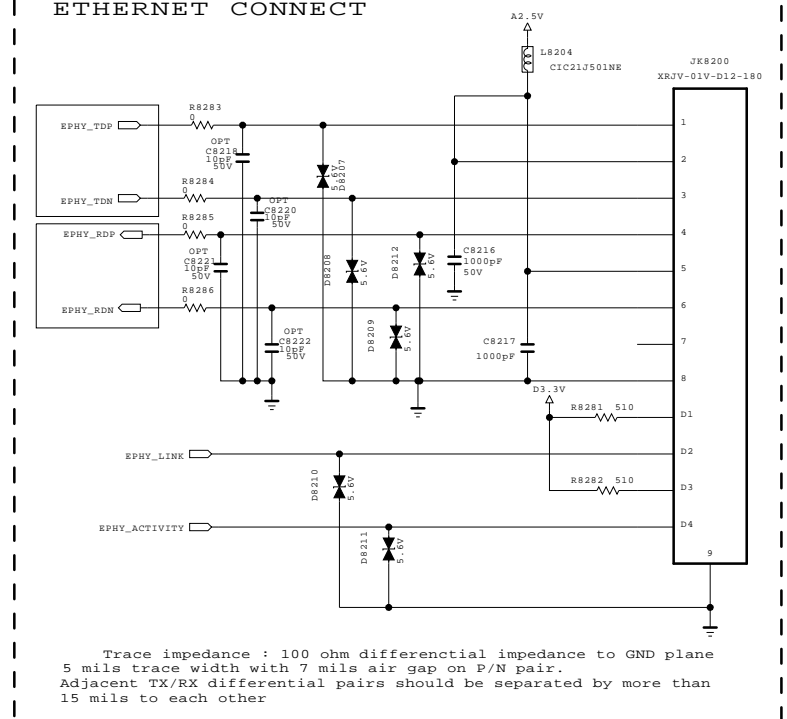

Trace impedance : 100 ohm differential impedance to GND plane
5 mils trace width with 7 mils air gap on P/N pair.
Adjacent TX/RX differential pairs should be separated by more than 15 mils to each other

RS232C

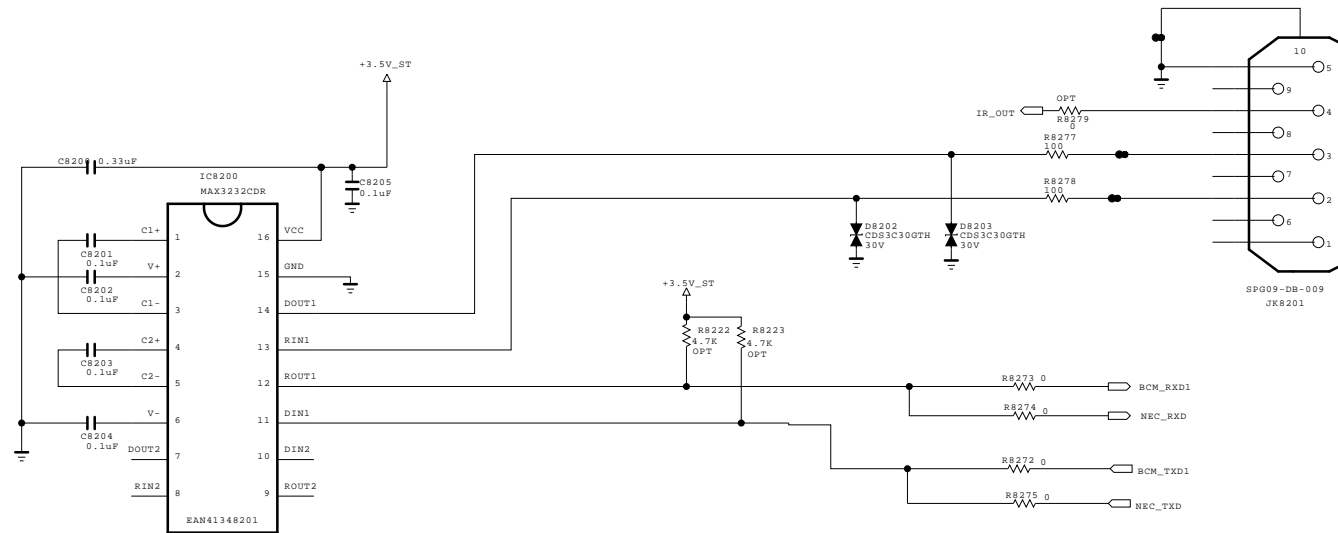

THE Δ SYMBOL MARK OF THIS SCHEMATIC DIAGRAM INCORPORATES SPECIAL FEATURES IMPORTANT FOR PROTECTION FROM X-RADIATION. FILRE AND ELECTRICAL SHOCK HAZARDS, WHEN SERVICING IF IS ESSENTIAL THAT ONLY MANUFACTURES SPECIFIED PARTS BE USED FOR THE CRITICAL COMPONENTS IN THE Δ SYMBOL MARK OF THE SCHEMATIC.

SECRET
LGElectronics



MODEL		DATE	
BLOCK		SHEET	

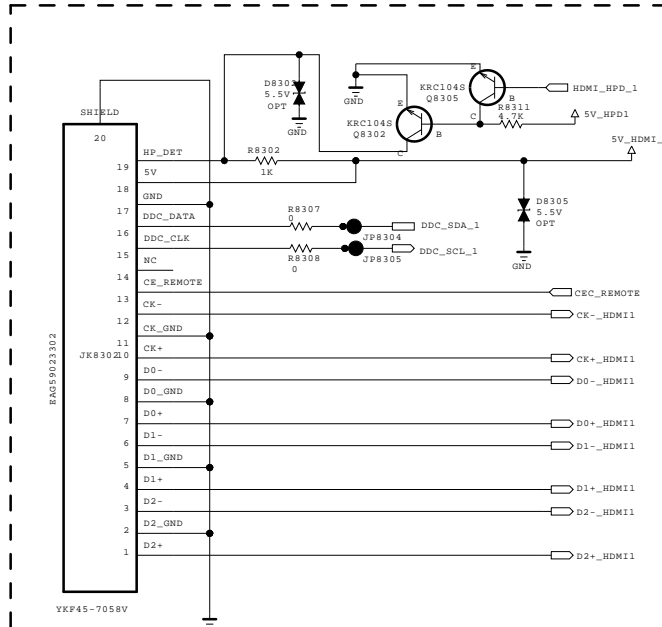

UI_HW_PORT1

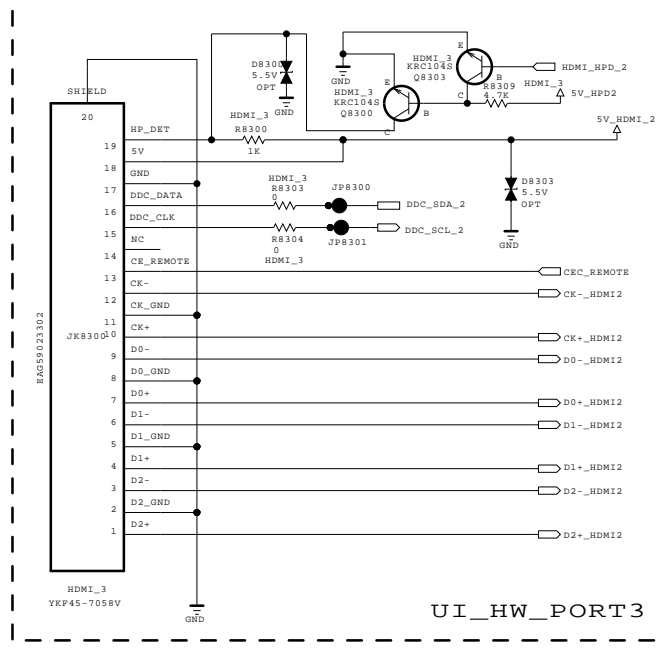

UI_HW_PORT3

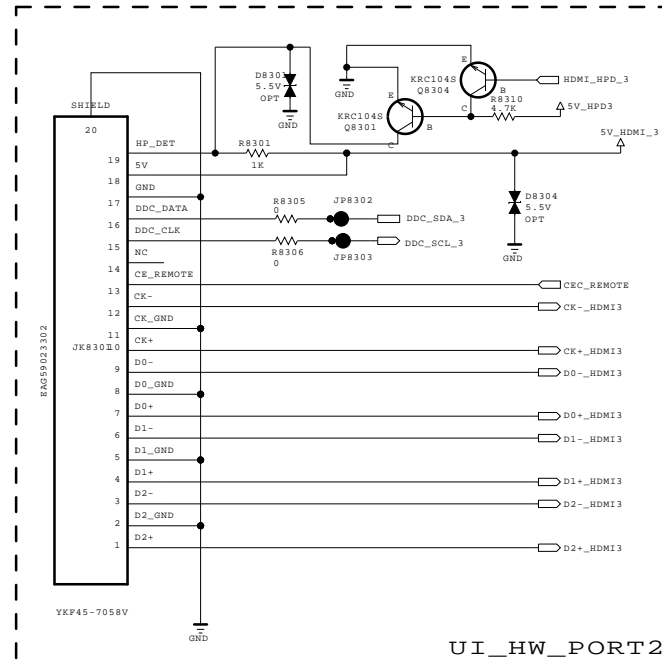

RGB_PC

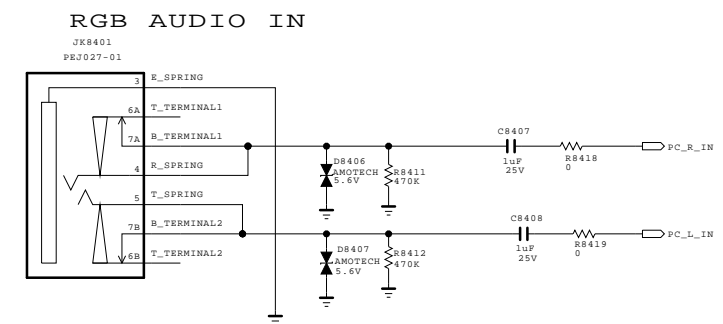
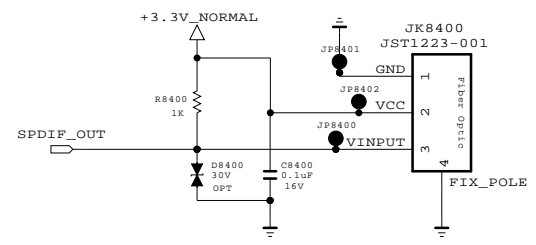
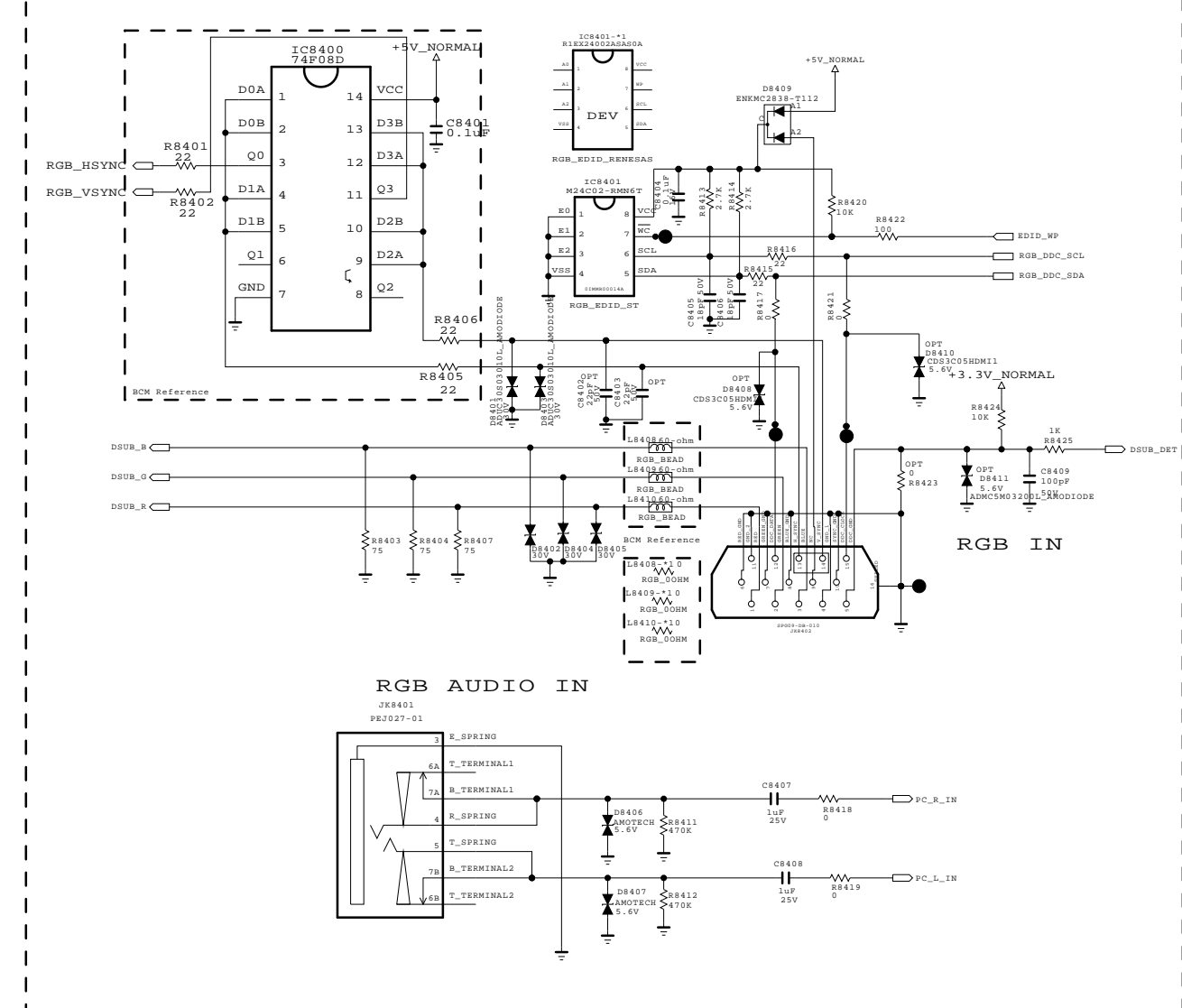

THE SYMBOL MARK OF THIS SCHEMATIC DIAGRAM INCORPORATES SPECIAL FEATURES IMPORTANT FOR PROTECTION FROM X-RADIATION. FILRE AND ELECTRICAL SHOCK HAZARDS, WHEN SERVICING IF IS ESSENTIAL THAT ONLY MANUFACTURES SPECIFIED PARTS BE USED FOR THE CRITICAL COMPONENTS IN THE SYMBOL MARK OF THE SCHEMATIC.

SECRET
LGElectronics



MODEL	EUROBBTV	DATE	2009.06.18
BLOCK	ETC SUB BOARD I/F	SHEET	9 /

ALL for SIDE_GENDER option

SIDE CVBS PHONE JACK
(New Item Development)

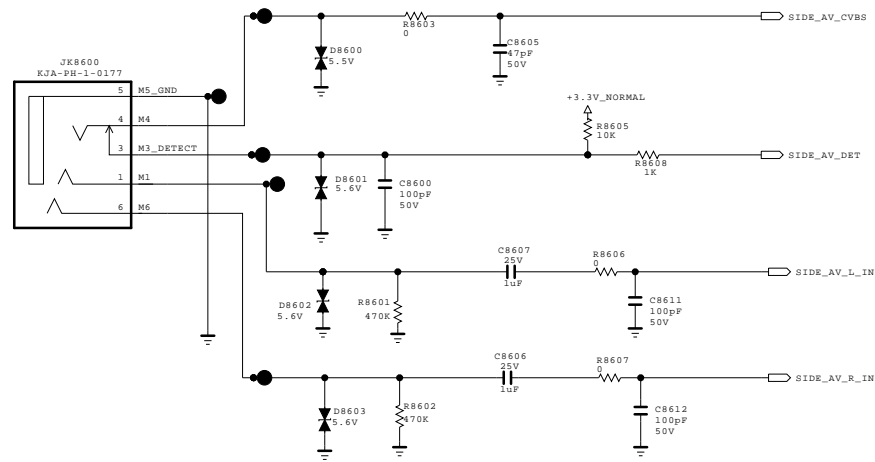

SIDE COMPONENT PHONE JACK
(New Item Development)

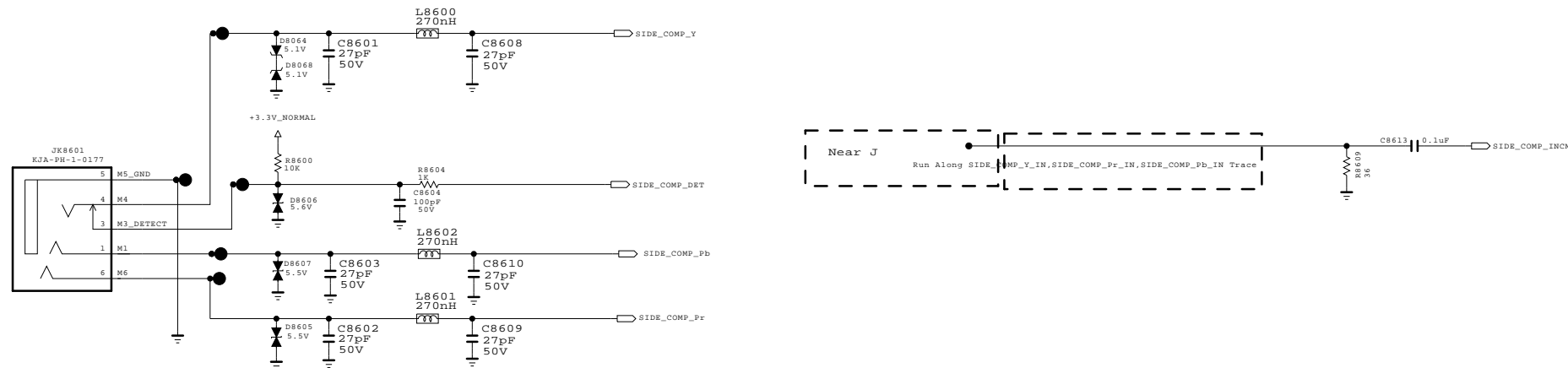

THE Δ SYMBOL MARK OF THIS SCHEMATIC DIAGRAM INCORPORATES SPECIAL FEATURES IMPORTANT FOR PROTECTION FROM X-RADIATION. FILRE AND ELECTRICAL SHOCK HAZARDS, WHEN SERVICING IF IS ESSENTIAL THAT ONLY MANUFACTURES SPECIFIED PARTS BE USED FOR THE CRITICAL COMPONENTS IN THE Δ SYMBOL MARK OF THE SCHEMATIC.

SECRET
LGElectronics



MODEL		DATE	
BLOCK		SHEET	11 /

WIRELESS READY MODEL

Wireless power

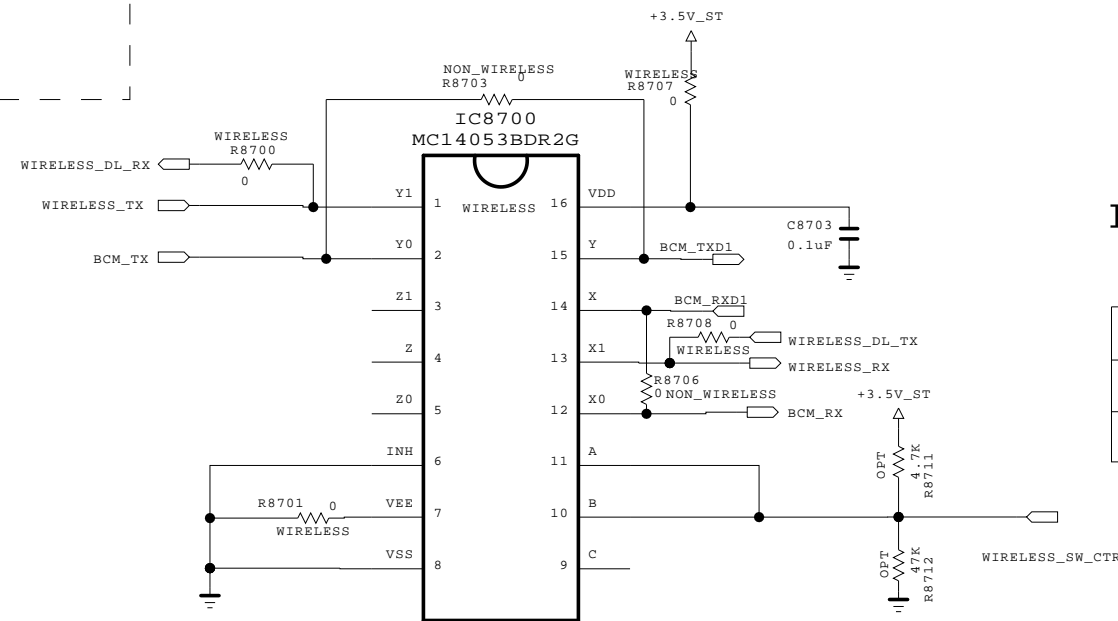
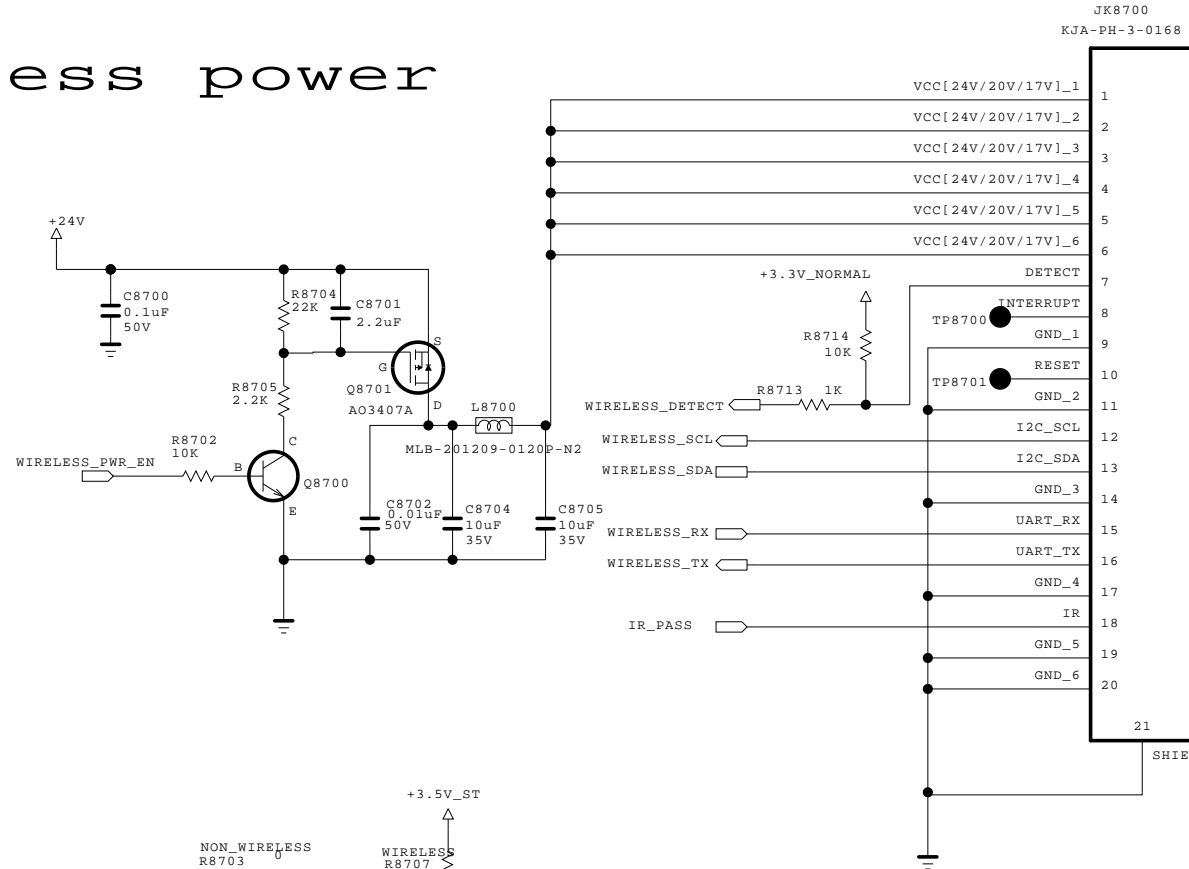
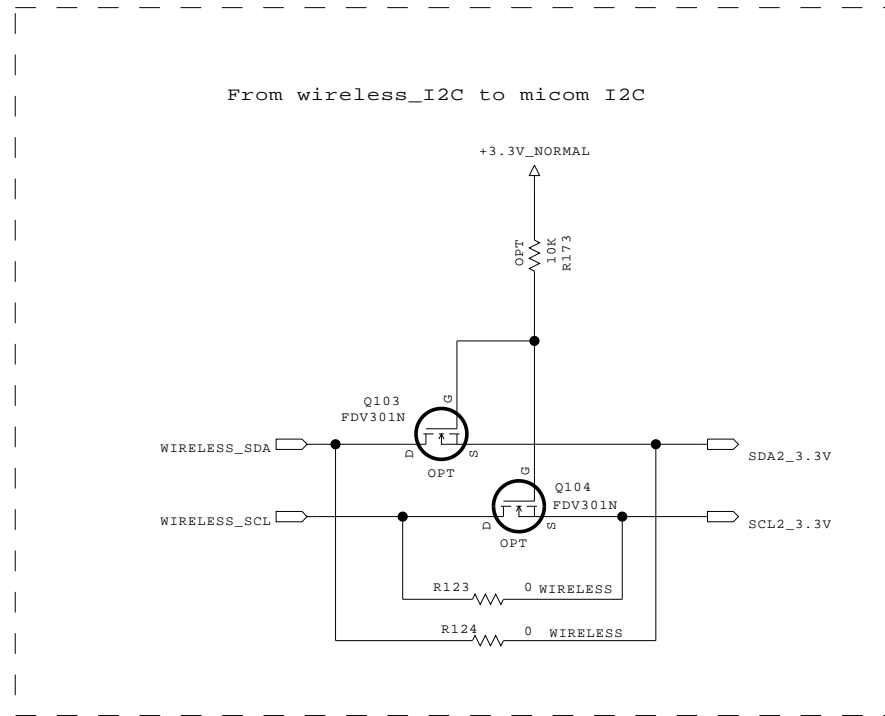

RS232C & Wireless

WIRELESS_SW_CTRL	SELECT PIN	STATUS
HIGH	X1/Y1/Z1	WIRELESS Dongle connect --> WIRELESS RS232
LOW	X0/Y0/Z0	WIRELESS Dongle Dis_con --> S7 RS232

THE SYMBOL MARK OF THIS SCHEMATIC DIAGRAM INCORPORATES SPECIAL FEATURES IMPORTANT FOR PROTECTION FROM X-RADIATION. FILRE AND ELECTRICAL SHOCK HAZARDS, WHEN SERVICING IF IS ESSENTIAL THAT ONLY MANUFACTURES SPECIFIED PARTS BE USED FOR THE CRITICAL COMPONENTS IN THE SYMBOL MARK OF THE SCHEMATIC.



MODEL		DATE	
BLOCK		SHEET	12 /

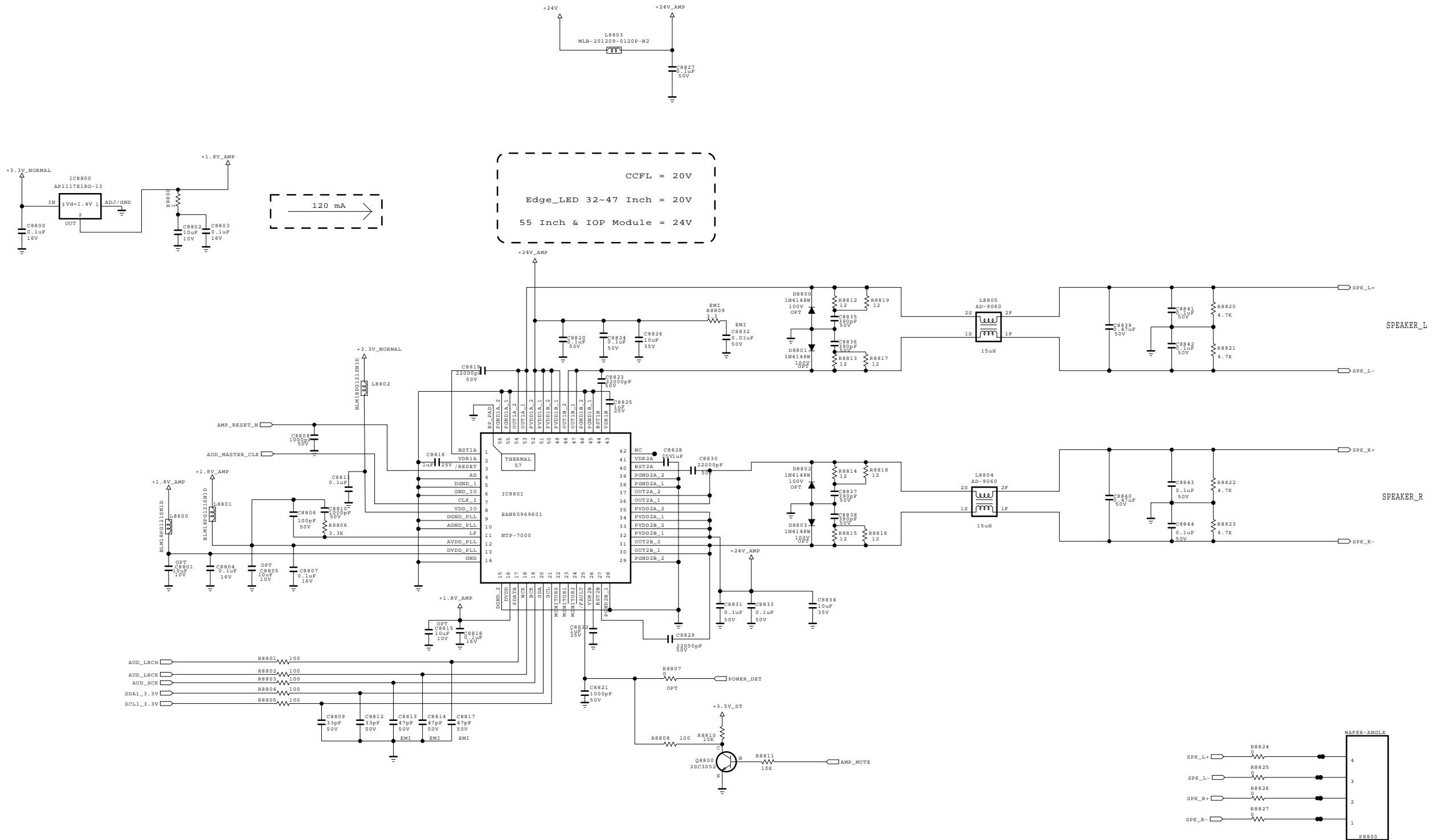

THE SYMBOL MARK OF THIS SCHEMATIC DIAGRAM INCORPORATES SPECIAL FEATURES IMPORTANT FOR PROTECTION FROM X-RADIATION. FILRE AND ELECTRICAL SHOCK HAZARDS, WHEN SERVICING IF IS ESSENTIAL THAT ONLY MANUFACTURES SPECIFIED PARTS BE USED FOR THE CRITICAL COMPONENTS IN THE SYMBOL MARK OF THE SCHEMATIC.

SECRET
LGElectronics

KIM JONG HYUN LG ELECTRONICS

MODEL	BCM (EUROBBTV)	DATE	2009.06.18
BLOCK	NTP7000	SHEET	38 /

IC9701
LG5111

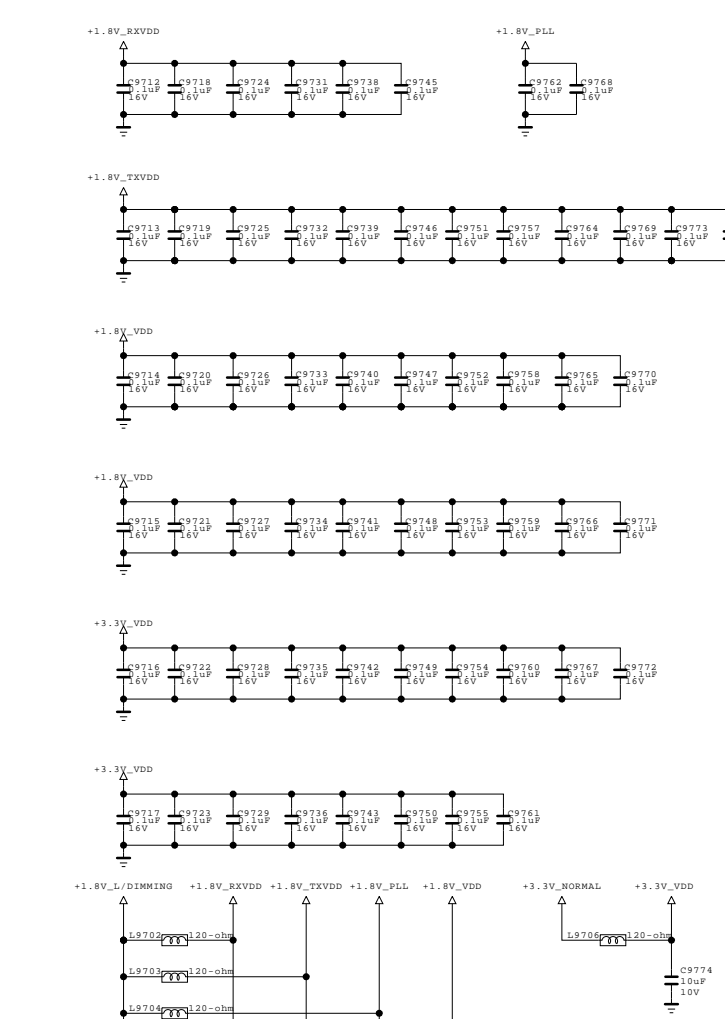
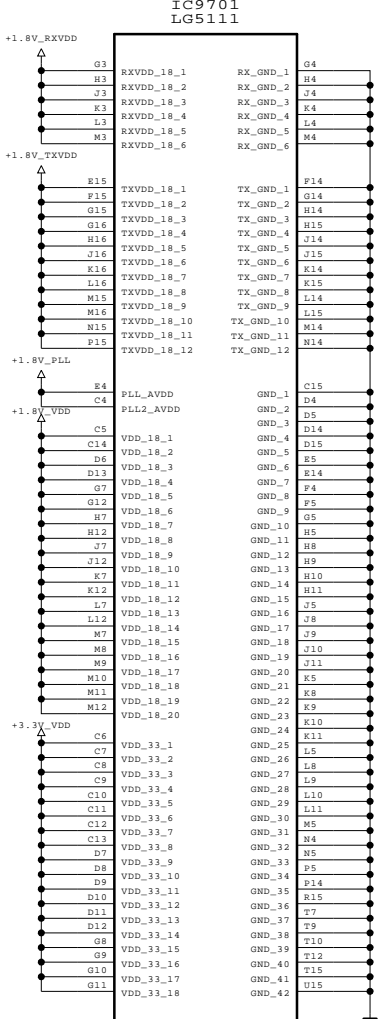
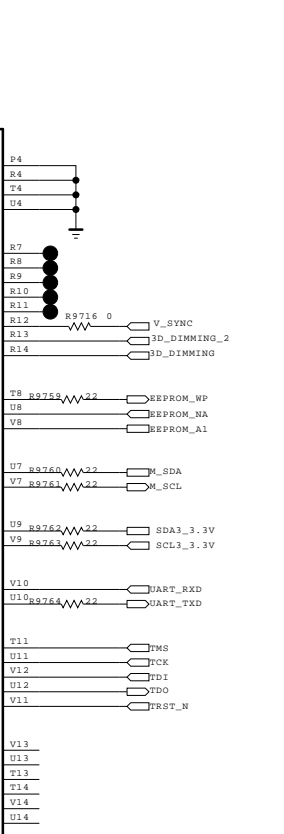
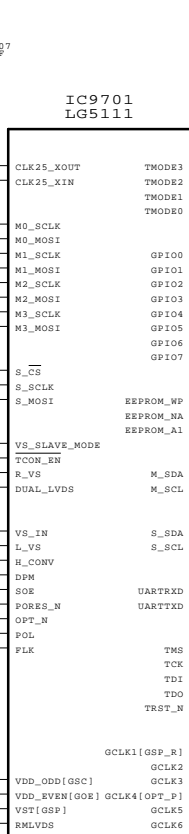
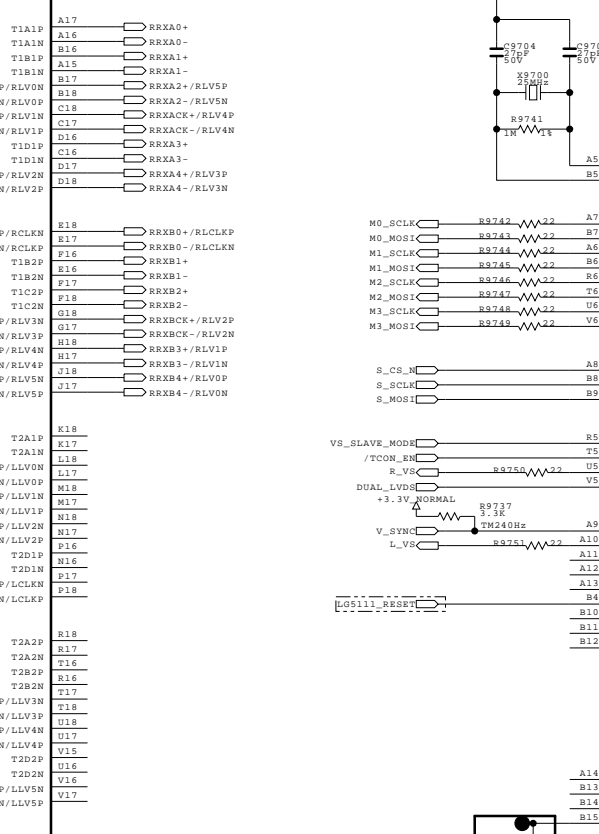
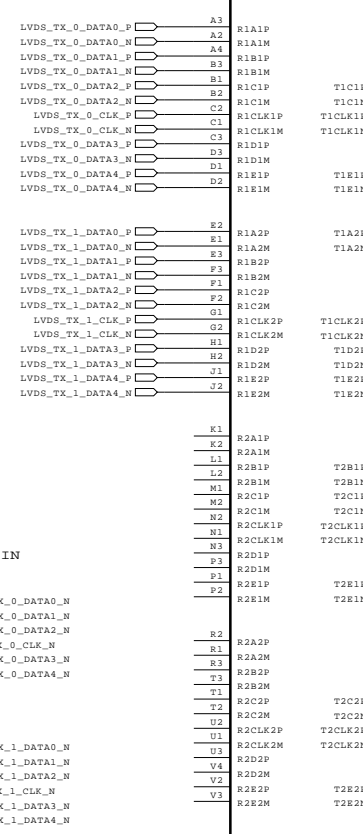

Close to LG5111 LVDS Input PIN

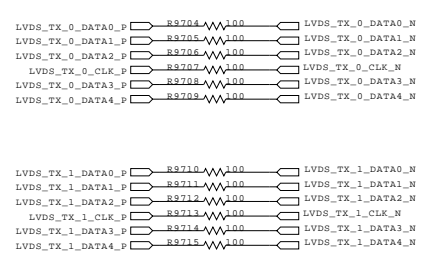

[Mini-LVDS Signal Strength]
1. Adjust Mini-LVDS Tx voltage swing level (swing level can be affected by FPC cable)
2. Add resistor and make option for each model

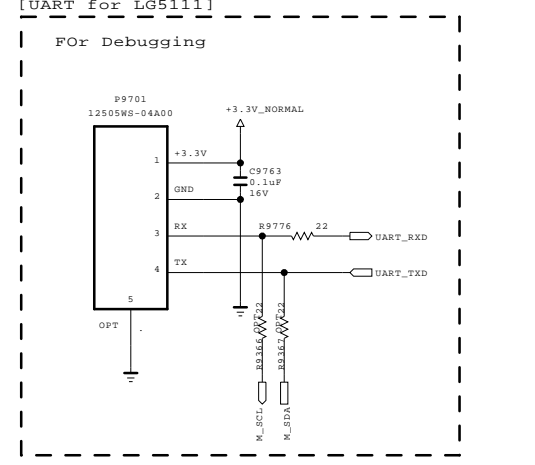
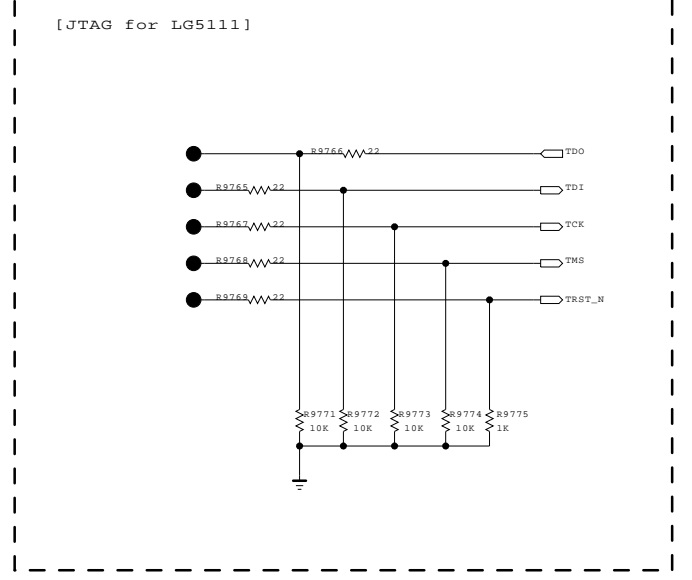
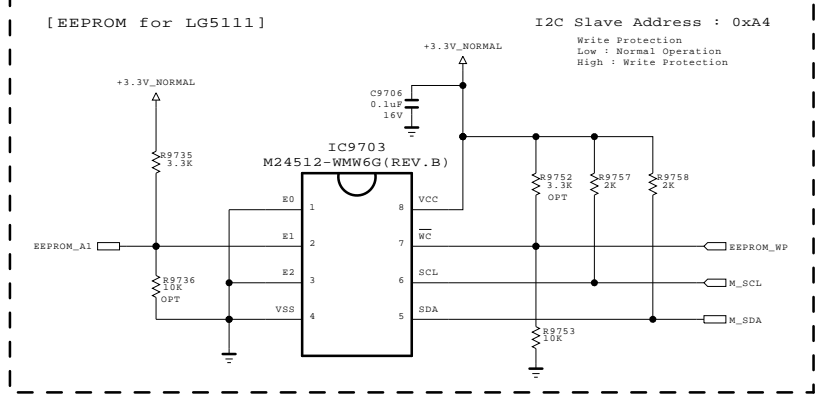
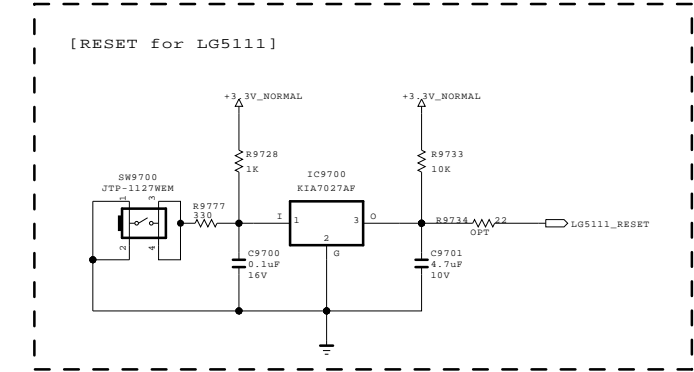
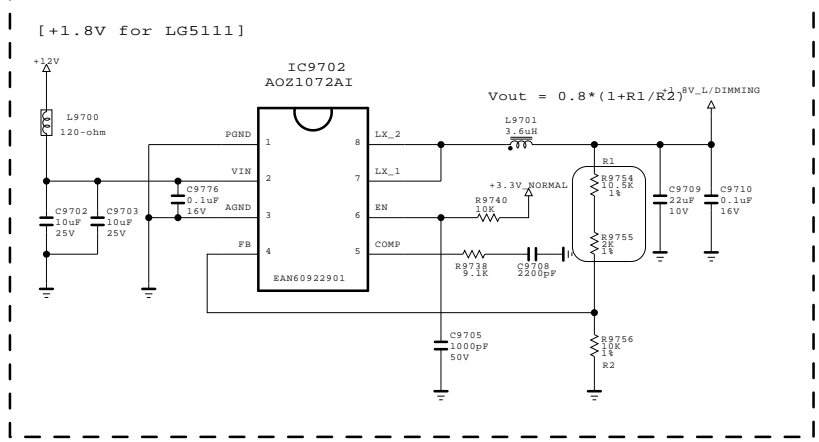
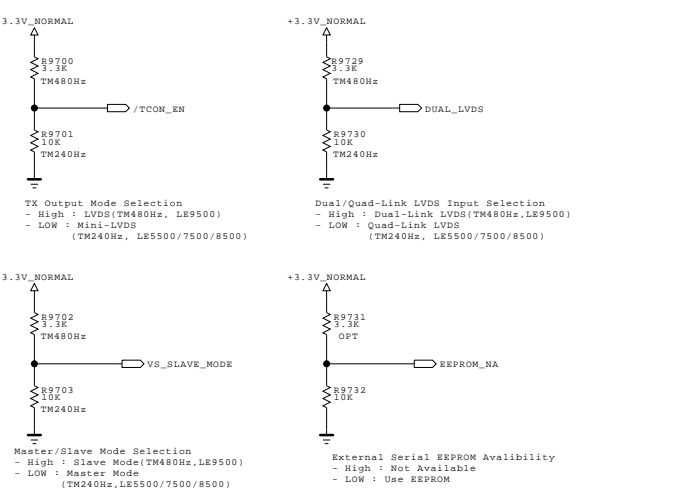

THE Δ SYMBOL MARK OF THIS SCHEMATIC DIAGRAM INCORPORATES SPECIAL FEATURES IMPORTANT FOR PROTECTION FROM X-RADIATION. FILRE AND ELECTRICAL SHOCK HAZARDS, WHEN SERVICING IF IS ESSENTIAL THAT ONLY MANUFACTURERS SPECIFIED PARTS BE USED FOR THE CRITICAL COMPONENTS IN THE Δ SYMBOL MARK OF THE SCHEMATIC.

SECRET
LGElectronics

LG ELECTRONICS

MODEL	COMMON_LD_400/480HZ	DATE	09/10/13
BLOCK	LG5111 (L.D.) from BCM	SHEET	97

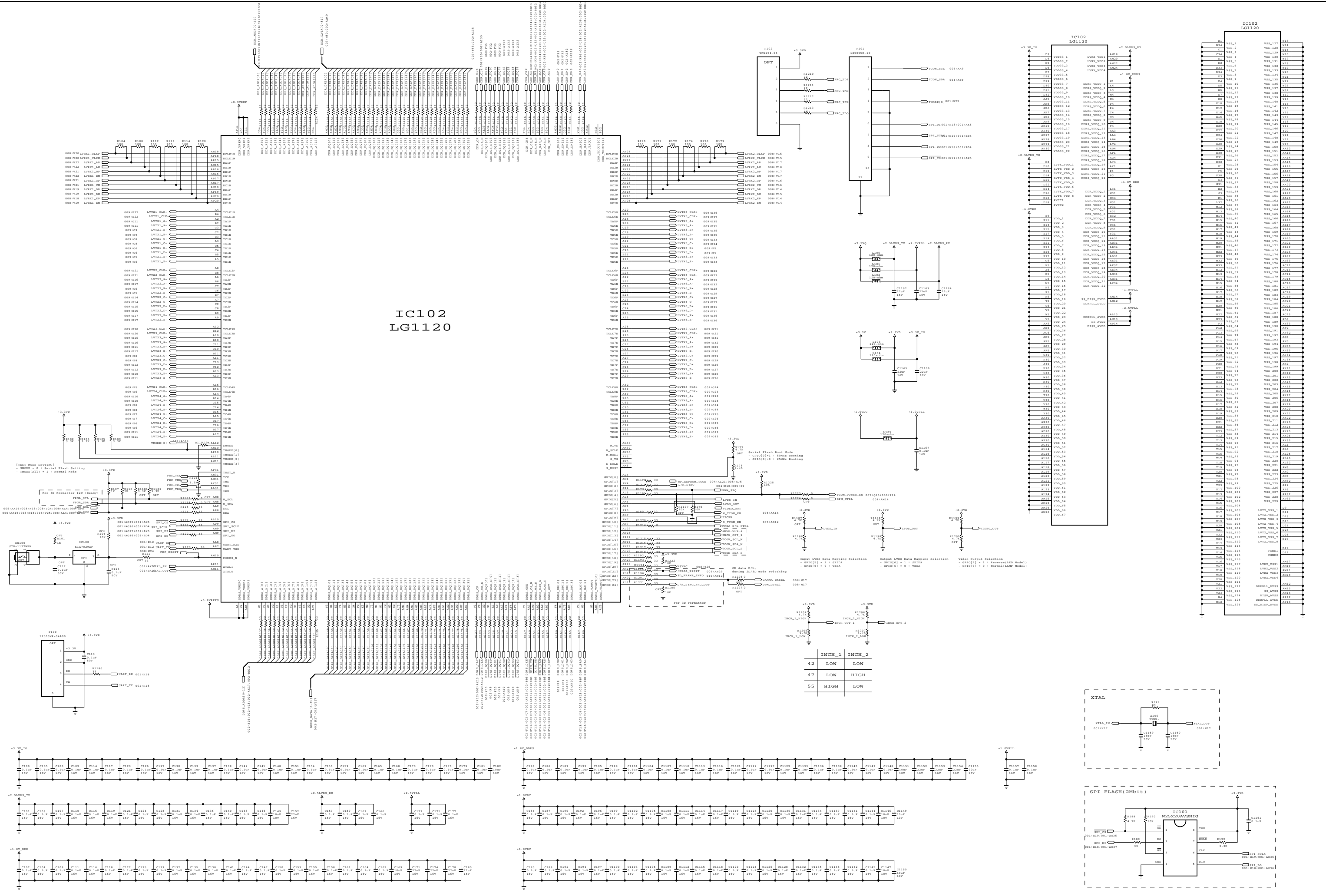

IC102
LG1120

	INCH_1	INCH_2
42	LOW	LOW
47	LOW	HIGH
55	HIGH	LOW

THE SYMBOL MARK OF THIS SCHEMATIC DIAGRAM INCORPORATES SPECIAL FEATURES IMPORTANT FOR PROTECTION FROM X-RADIATION. FILRE AND ELECTRICAL SHOCK HAZARDS, WHEN SERVICING IF IS ESSENTIAL THAT ONLY MANUFACTURES SPECIFIED PARTS BE USED FOR THE CRITICAL COMPONENTS IN THE SYMBOL MARK OF THE SCHEMATIC.

SECRET
LGElectronics



MODEL	3D + 240 PRC + TCON BOARD	DATE	2009. 11. 13
BLOCK	M31120 (PRC 240Hz Chip)	SHEET	1 / 10

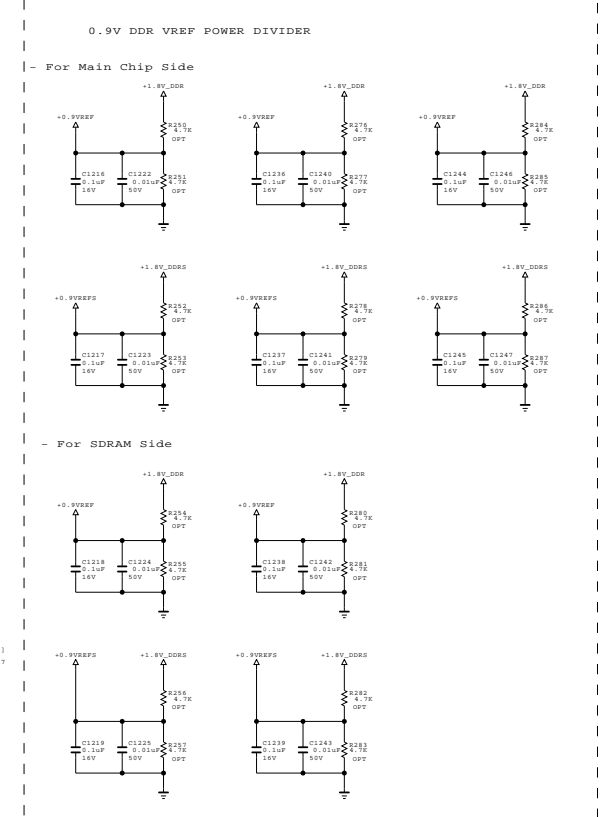
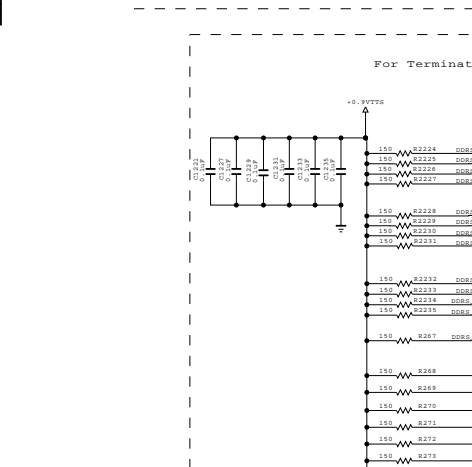
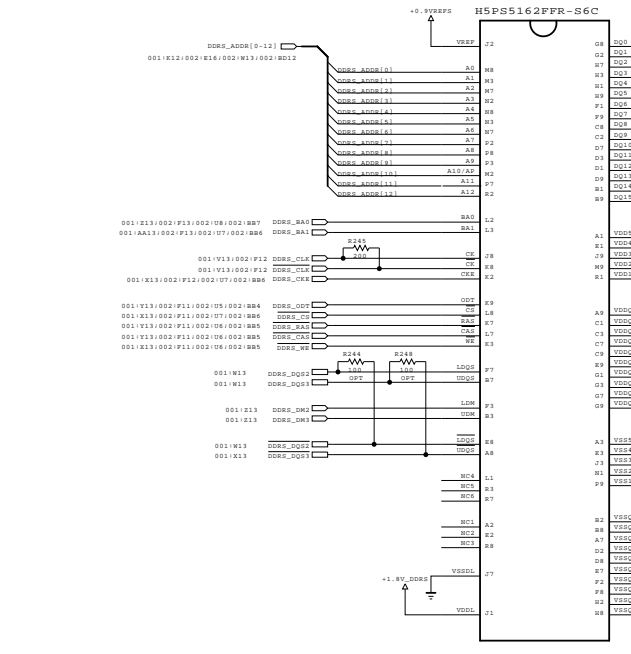
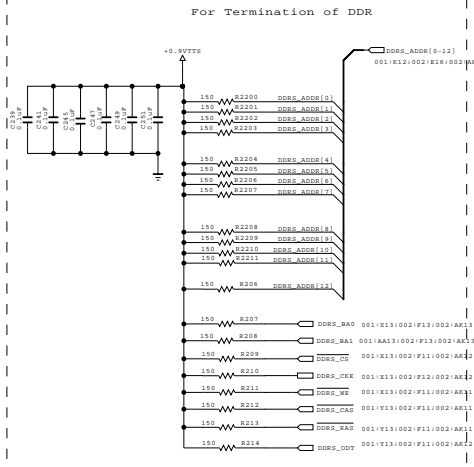
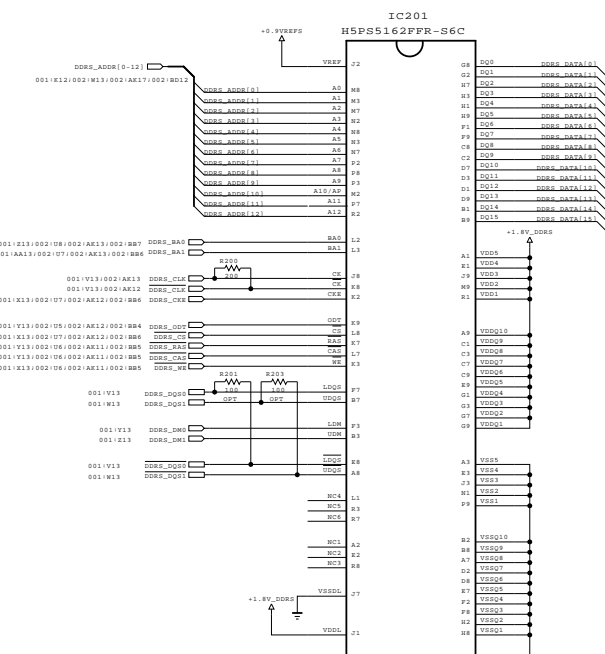
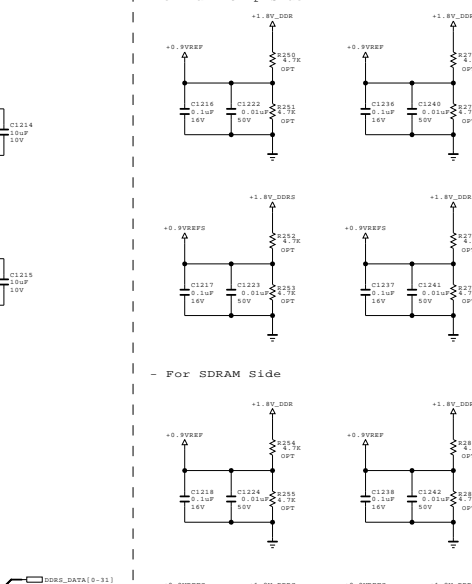
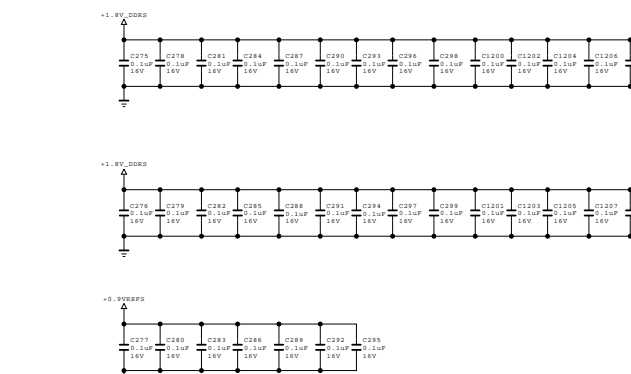
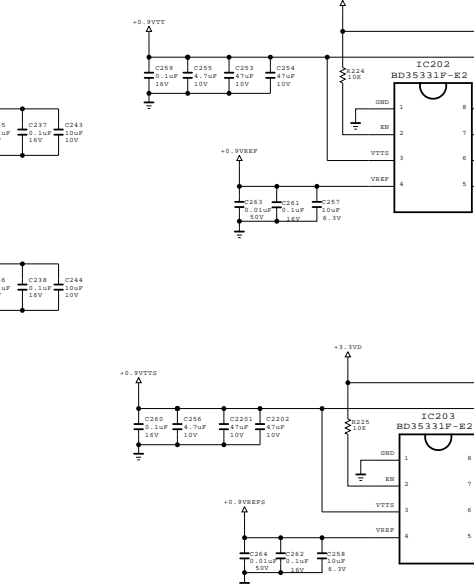
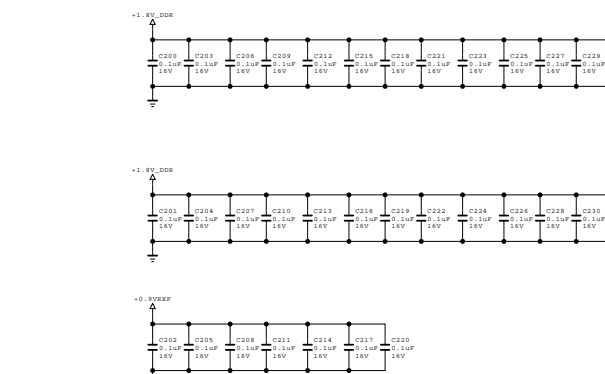
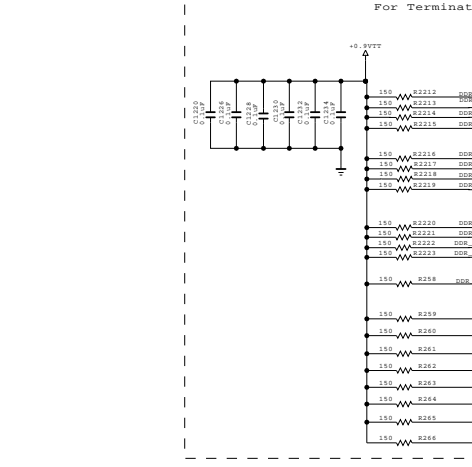
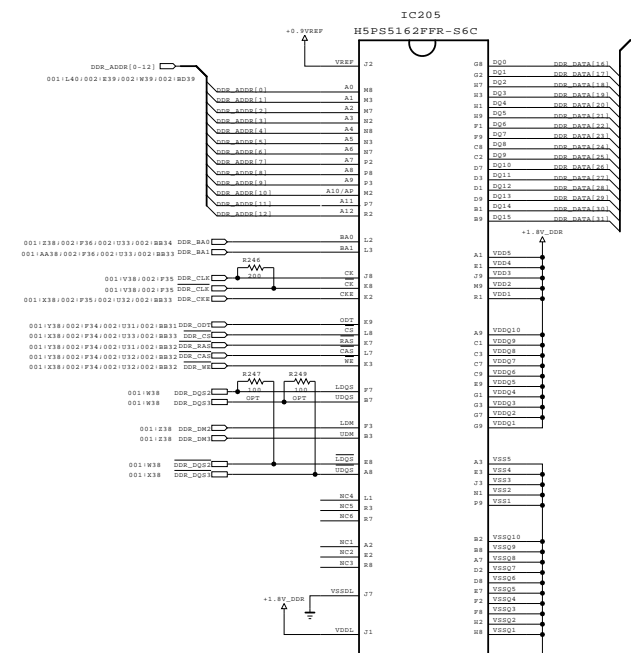
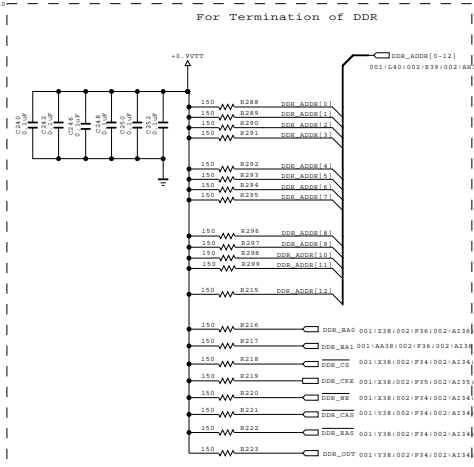
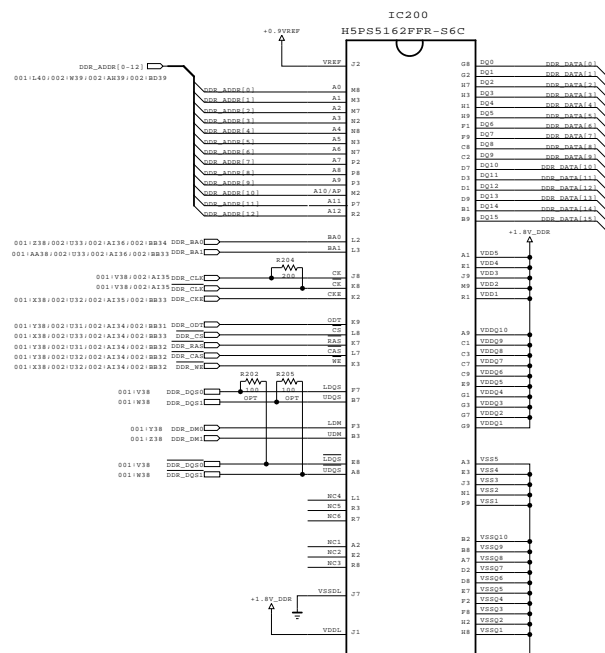

THE Δ SYMBOL MARK OF THIS SCHEMATIC DIAGRAM INCORPORATES SPECIAL FEATURES IMPORTANT FOR PROTECTION FROM X-RADIATION. FILRE AND ELECTRICAL SHOCK HAZARDS, WHEN SERVICING IF IS ESSENTIAL THAT ONLY MANUFACTURES SPECIFIED PARTS BE USED FOR THE CRITICAL COMPONENTS IN THE Δ SYMBOL MARK OF THE SCHEMATIC.

SECRET
LGElectronics



MODEL	3d + 240 PRC + TCON BOARD	DATE	2009. 11. 13
BLOCK	DDR2 SDRAM	SHEET	2 / 10

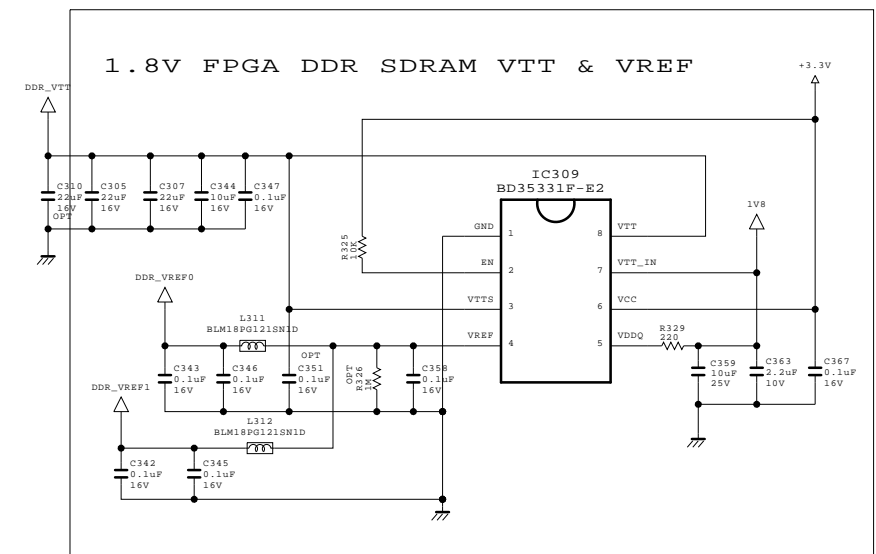
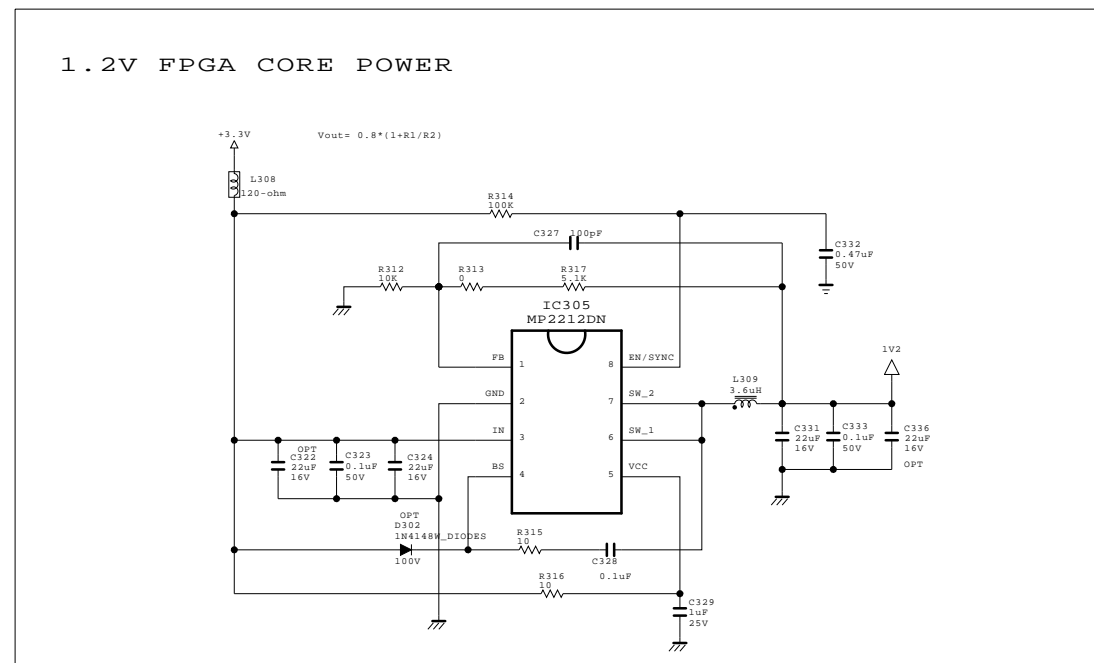
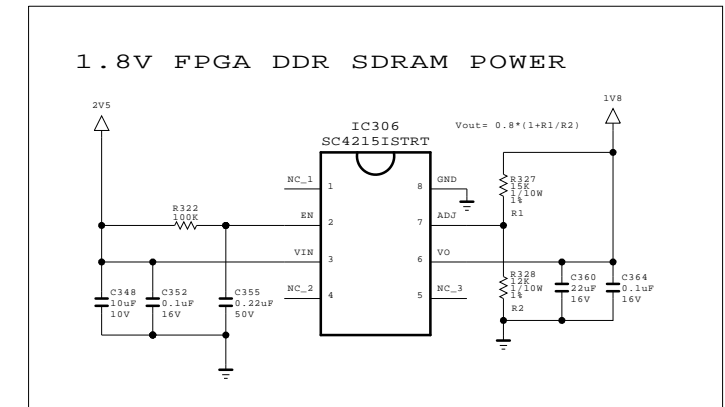
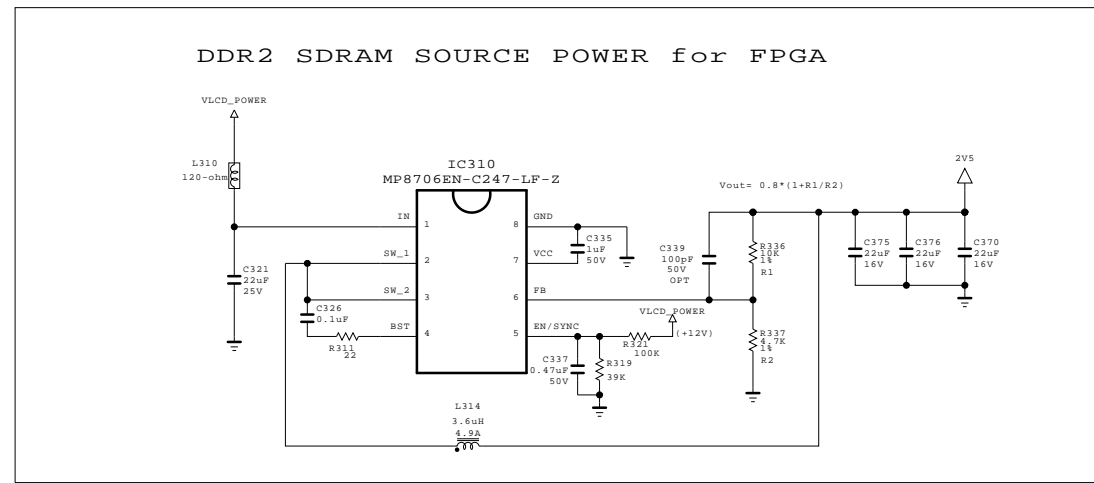
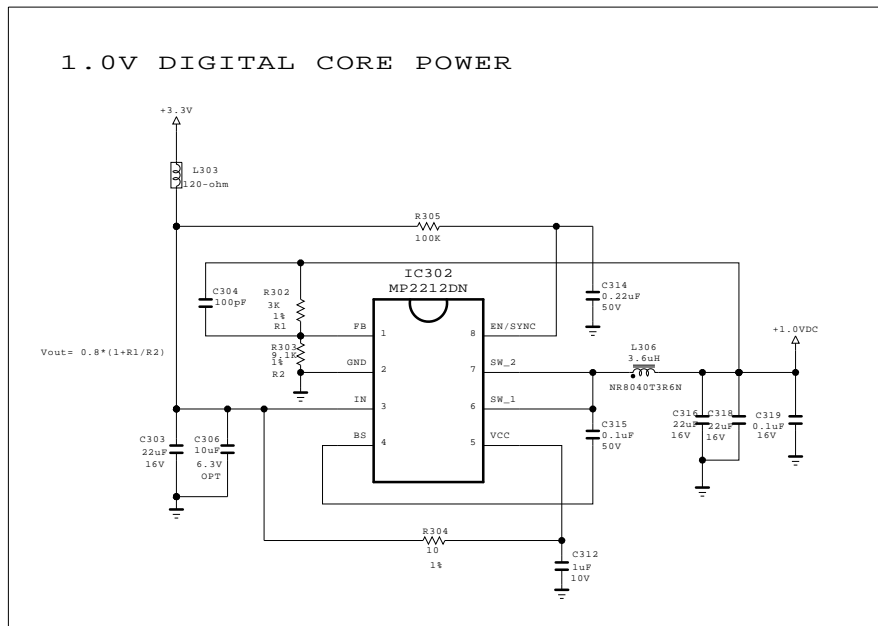
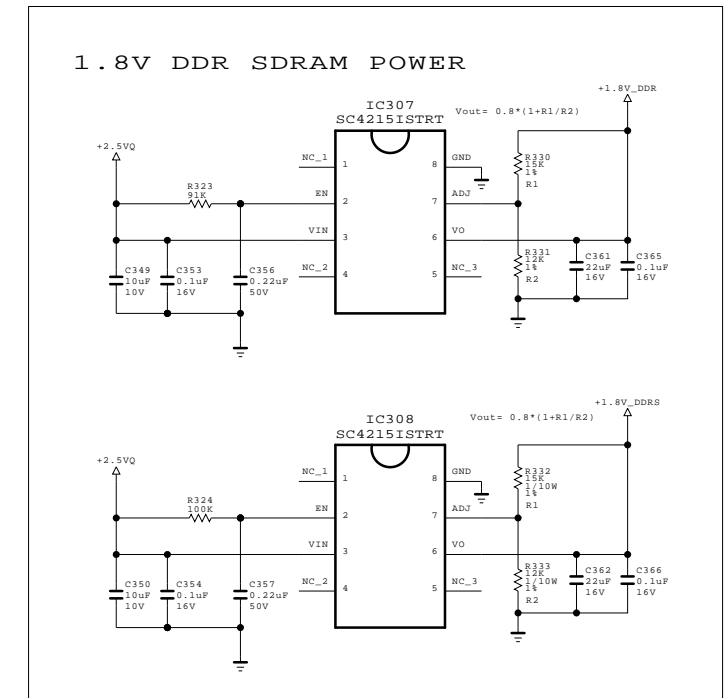
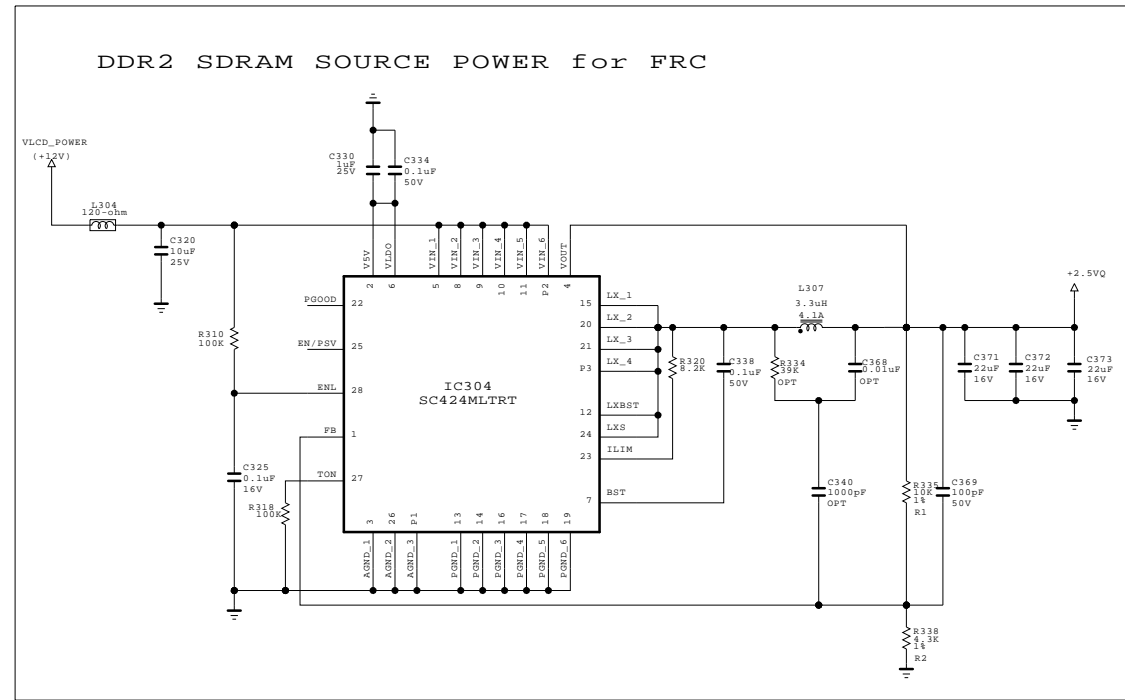
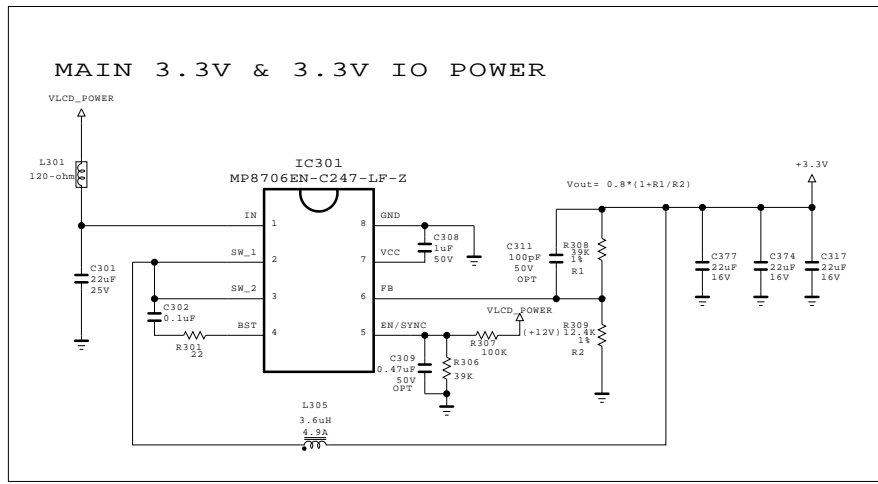

THE Δ SYMBOL MARK OF THIS SCHEMATIC DIAGRAM INCORPORATES SPECIAL FEATURES IMPORTANT FOR PROTECTION FROM X-RADIATION. FILRE AND ELECTRICAL SHOCK HAZARDS, WHEN SERVICING IF IS ESSENTIAL THAT ONLY MANUFACTURES SPECIFIED PARTS BE USED FOR THE CRITICAL COMPONENTS IN THE Δ SYMBOL MARK OF THE SCHEMATIC.

SECRET
LGElectronics



MODEL	3D + 240 FRC + TCON BOARD	DATE	2009. 11. 13
BLOCK	FRC & FPGA Power Block	SHEET	3 / 10

[T-CON RIGHT => Slave]

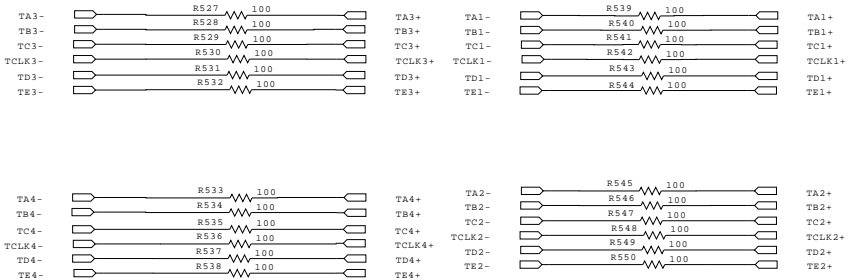
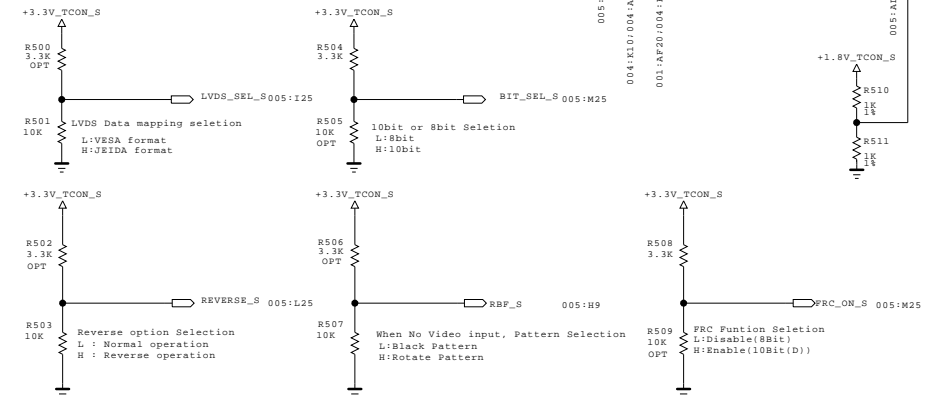
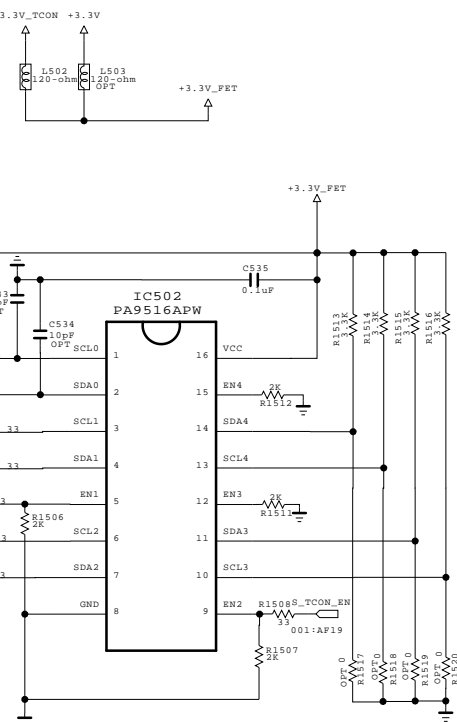
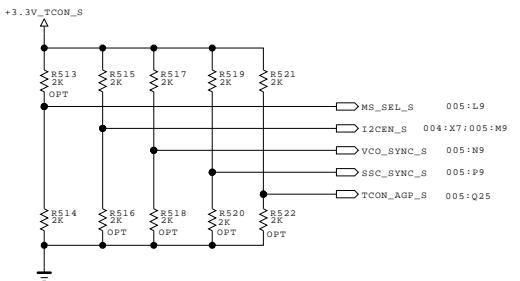
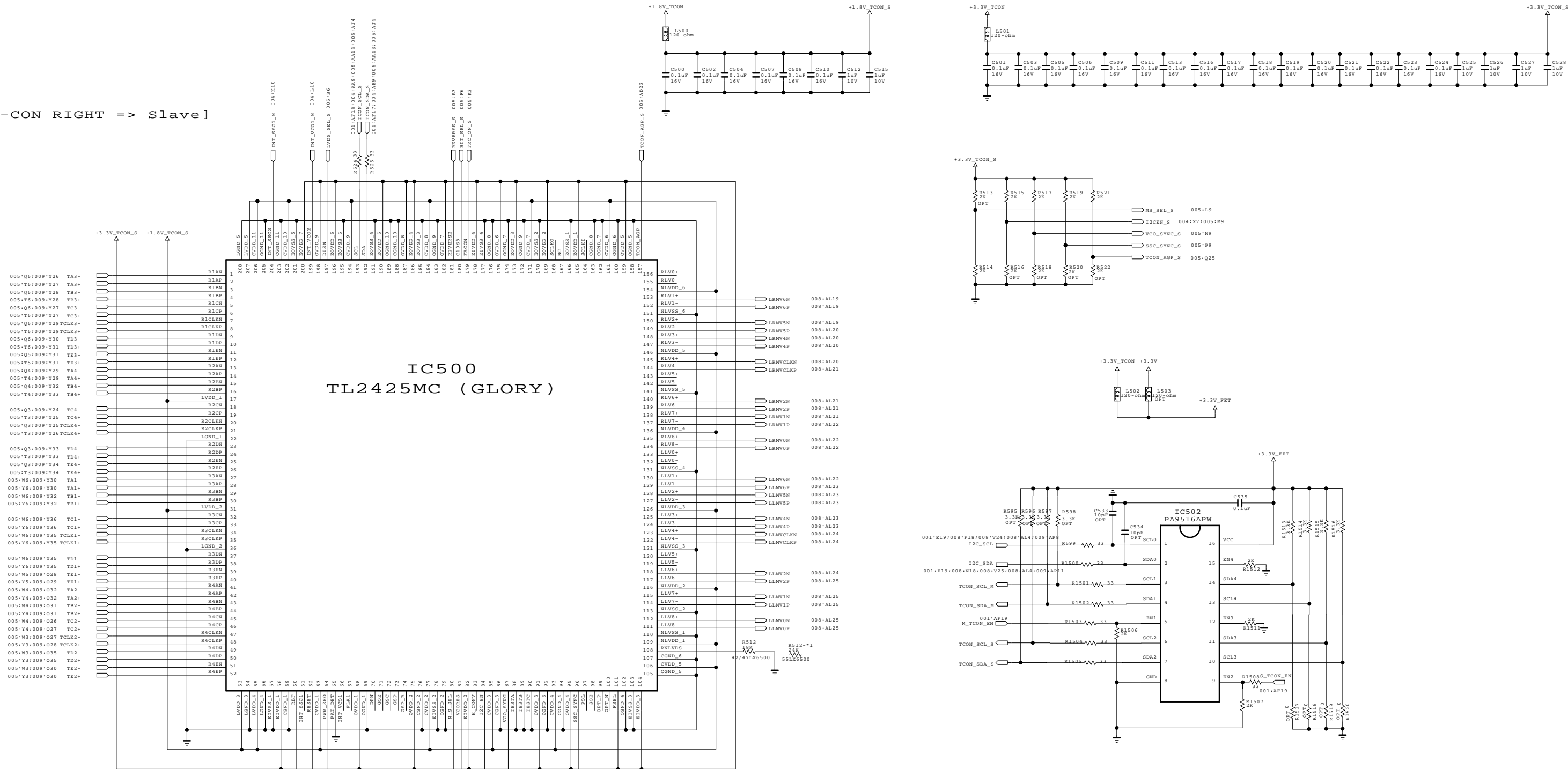

[TCON EEPROM(16Kbit)]

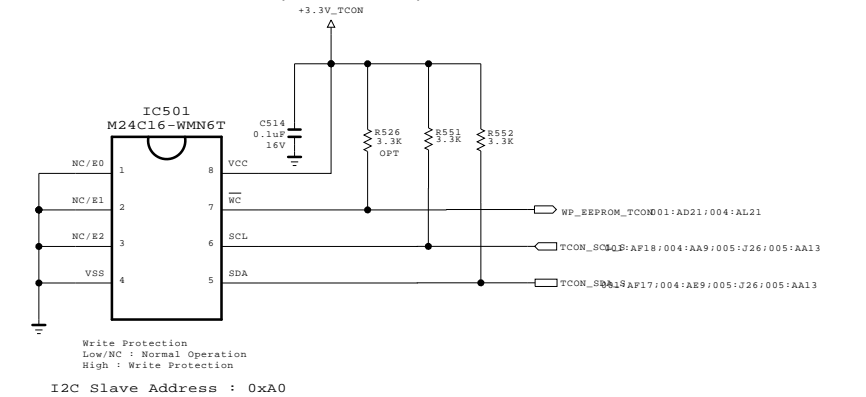

THE Δ SYMBOL MARK OF THIS SCHEMATIC DIAGRAM INCORPORATES SPECIAL FEATURES IMPORTANT FOR PROTECTION FROM X-RADIATION. FILRE AND ELECTRICAL SHOCK HAZARDS, WHEN SERVICING IF IS ESSENTIAL THAT ONLY MANUFACTURES SPECIFIED PARTS BE USED FOR THE CRITICAL COMPONENTS IN THE Δ SYMBOL MARK OF THE SCHEMATIC.

SECRET
LGElectronics



MODEL	3D + 240 FRC + TCON BOARD	DATE	2009. 11. 13
BLOCK	240Hz T-Con(Slave,Right)	SHEET	5 / 10

[POWER-VDD/VCC/VGH/VGL]

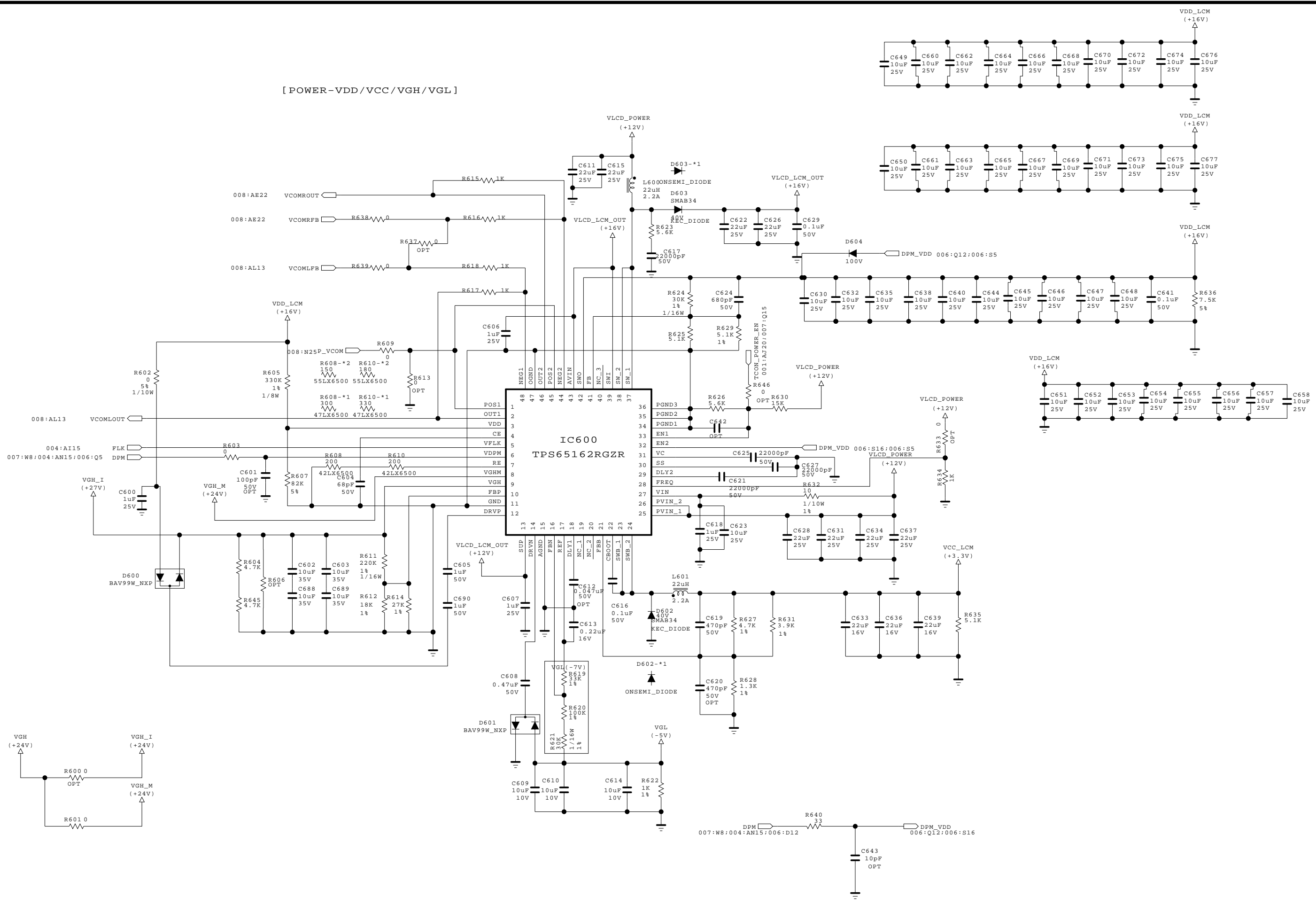

THE SYMBOL MARK OF THIS SCHEMATIC DIAGRAM INCORPORATES SPECIAL FEATURES IMPORTANT FOR PROTECTION FROM X-RADIATION. FILRE AND ELECTRICAL SHOCK HAZARDS, WHEN SERVICING IF IS ESSENTIAL THAT ONLY MANUFACTURES SPECIFIED PARTS BE USED FOR THE CRITICAL COMPONENTS IN THE SYMBOL MARK OF THE SCHEMATIC.

SECRET	
LGElectronics	

MODEL	3D + 240 FRC + TCON BOARD	DATE	2009. 11. 13
BLOCK	Power Block (TCON)	SHEET	6 / 10

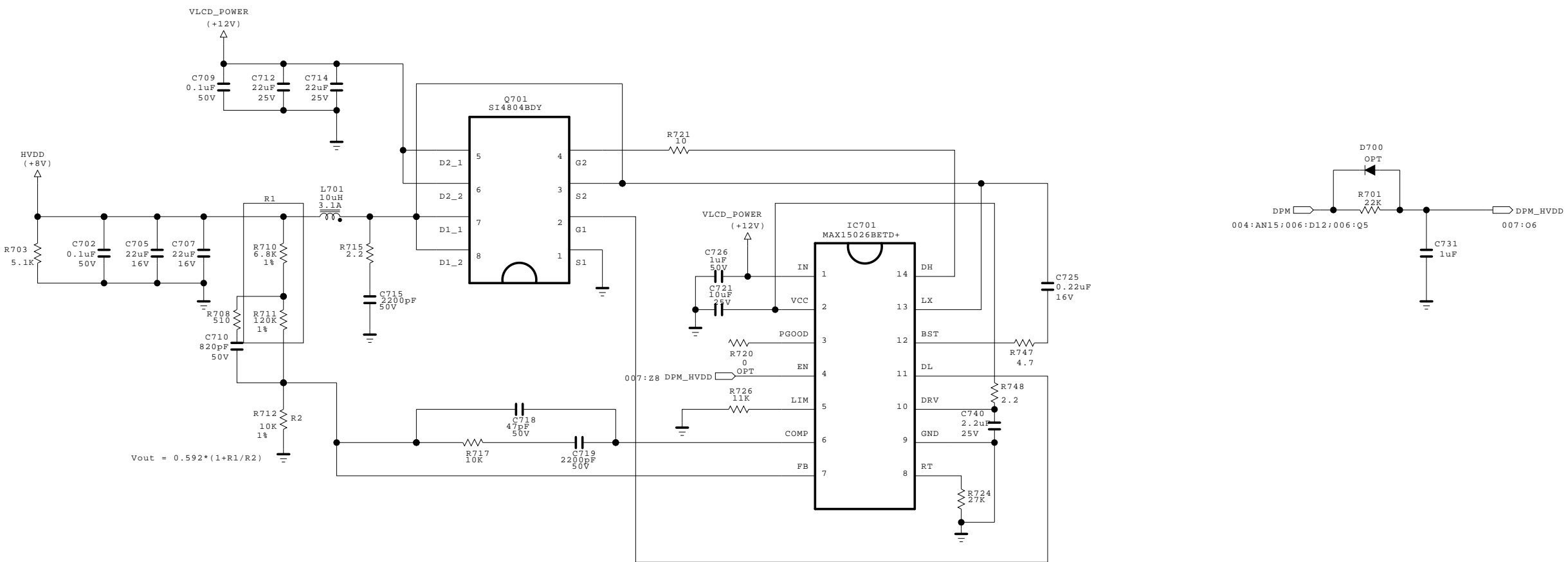
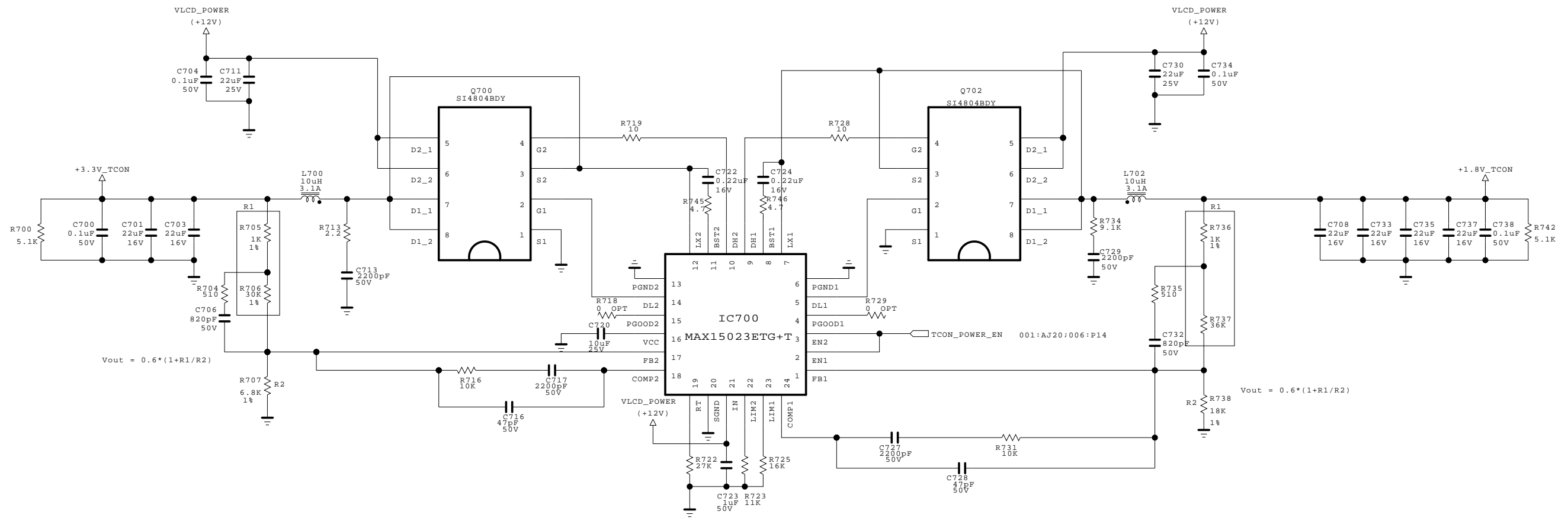

THE ⚠ SYMBOL MARK OF THIS SCHEMATIC DIAGRAM INCORPORATES SPECIAL FEATURES IMPORTANT FOR PROTECTION FROM X-RADIATION. FILRE AND ELECTRICAL SHOCK HAZARDS, WHEN SERVICING IF IS ESSENTIAL THAT ONLY MANUFACTURES SPECIFIED PARTS BE USED FOR THE CRITICAL COMPONENTS IN THE ⚠ SYMBOL MARK OF THE SCHEMATIC.

SECRET	
LGElectronics	

MODEL	3D + 240 FRC + TCON BOARD	DATE	2009. 11. 13
BLOCK	Power Block (TCON)	SHEET	7 / 10

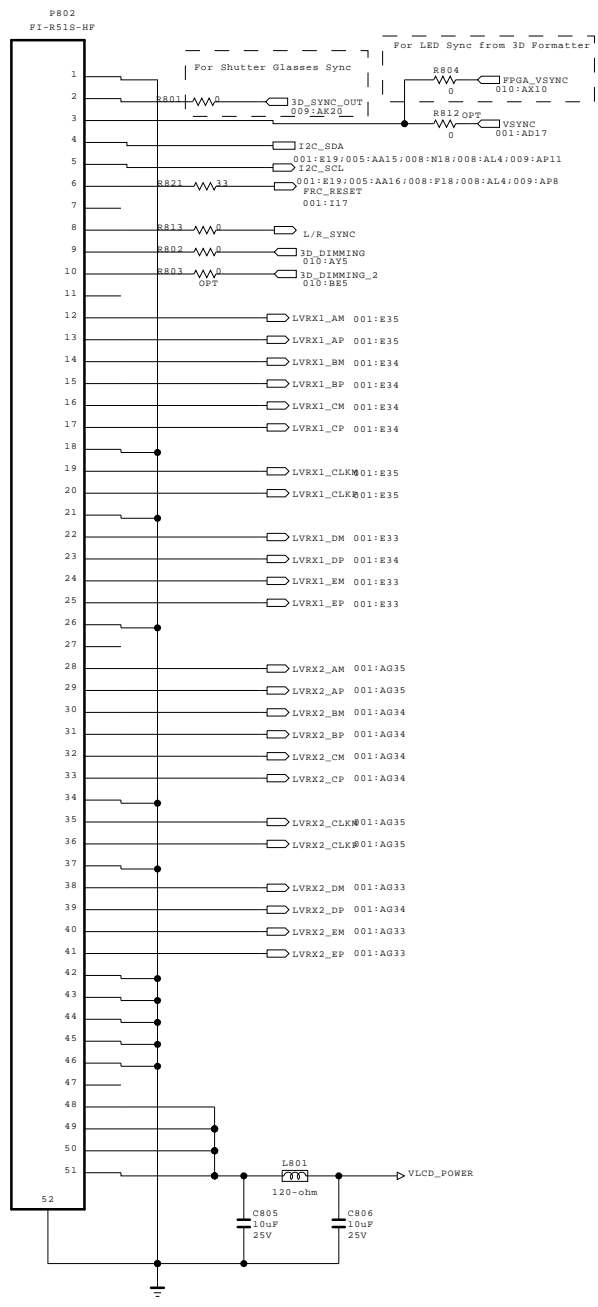
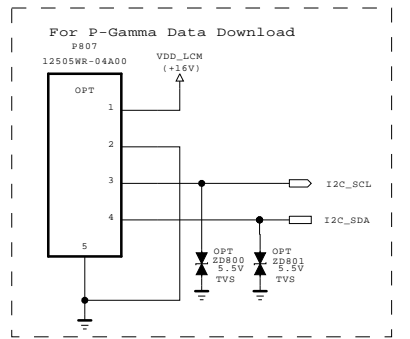
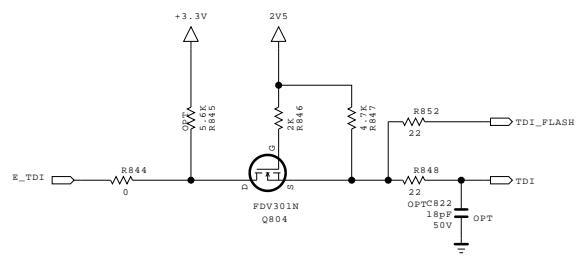
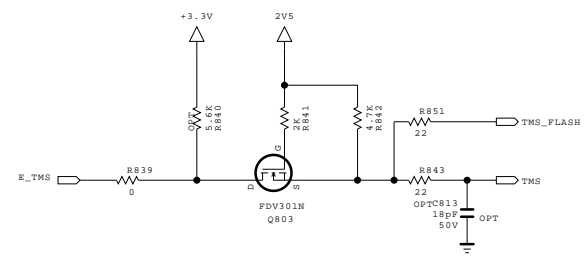
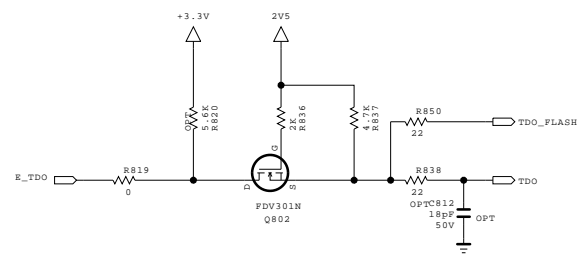
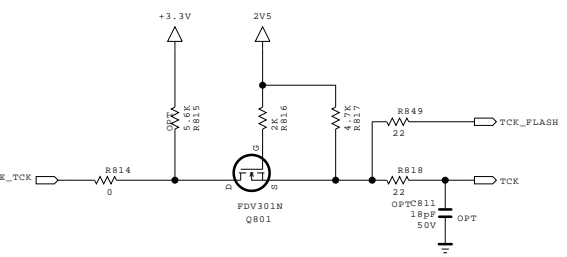
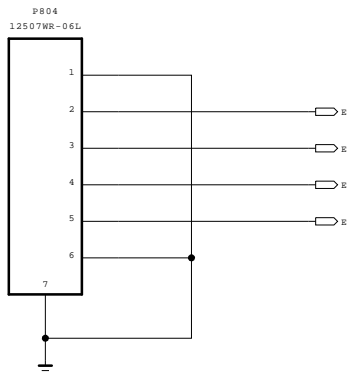
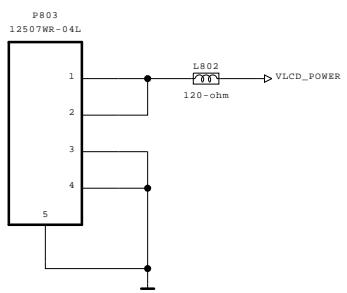
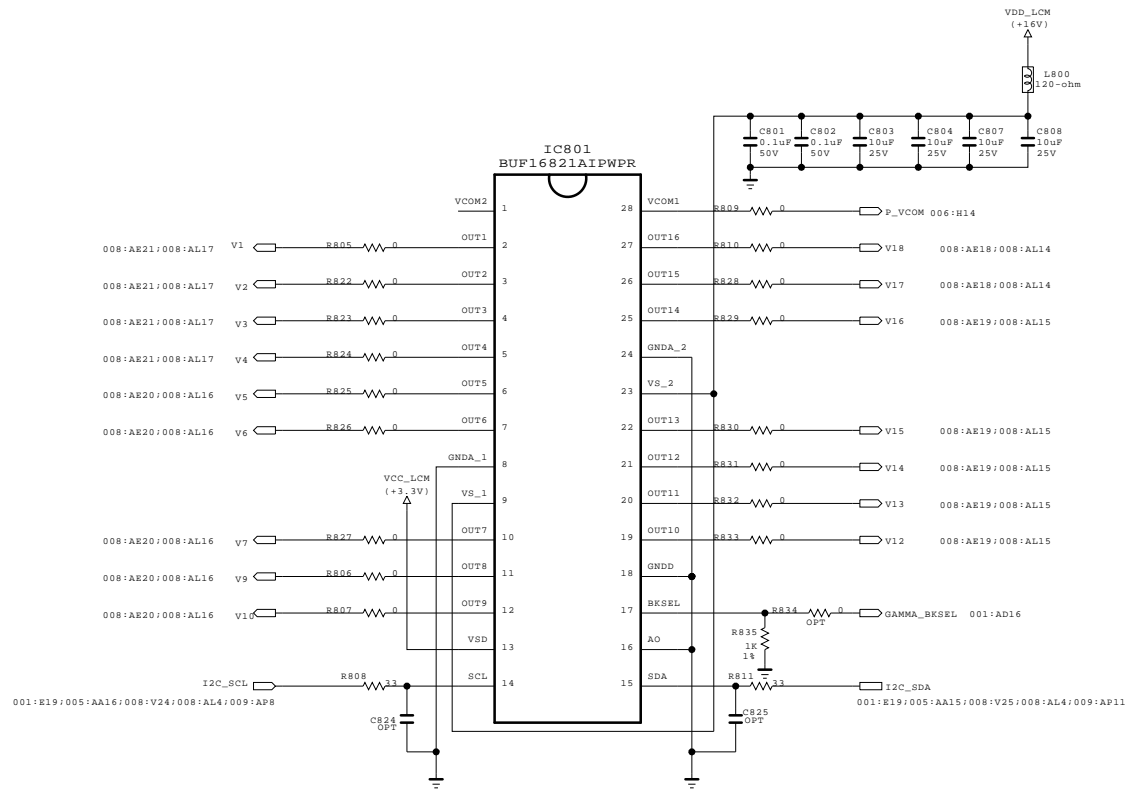

[RIGHT FFC CONNECTOR]

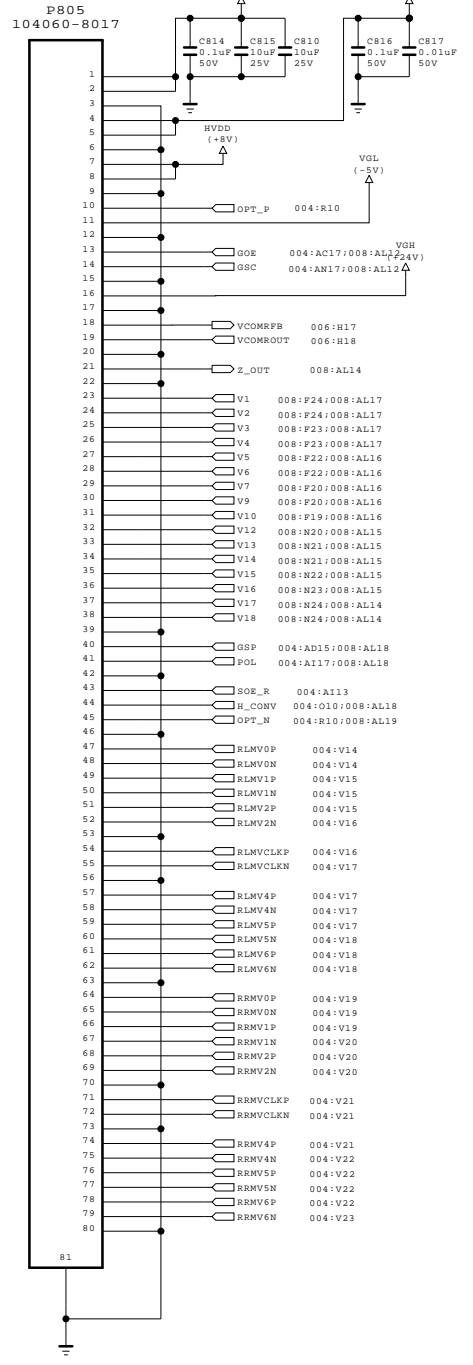

[LEFT FFC CONNECTOR]

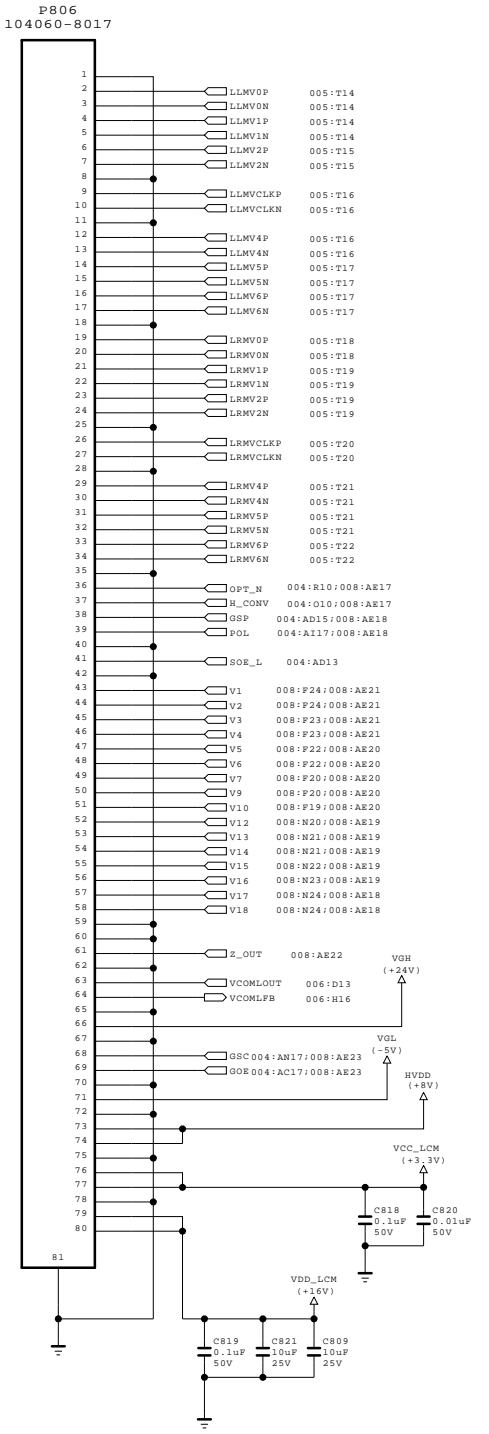

THE Δ SYMBOL MARK OF THIS SCHEMATIC DIAGRAM INCORPORATES SPECIAL FEATURES IMPORTANT FOR PROTECTION FROM X-RADIATION. FILRE AND ELECTRICAL SHOCK HAZARDS, WHEN SERVICING IF IS ESSENTIAL THAT ONLY MANUFACTURES SPECIFIED PARTS BE USED FOR THE CRITICAL COMPONENTS IN THE Δ SYMBOL MARK OF THE SCHEMATIC.

SECRET
LGElectronics



MODEL	3D + 240 FRC + TCON BOARD	DATE	2009. 11. 13
BLOCK	Interface	SHEET	8 / 10

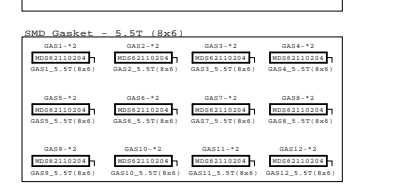
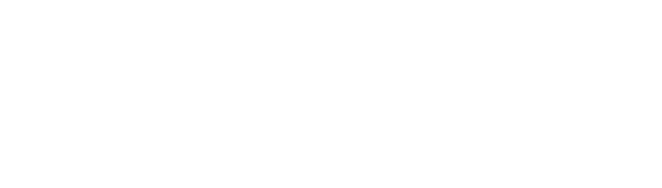
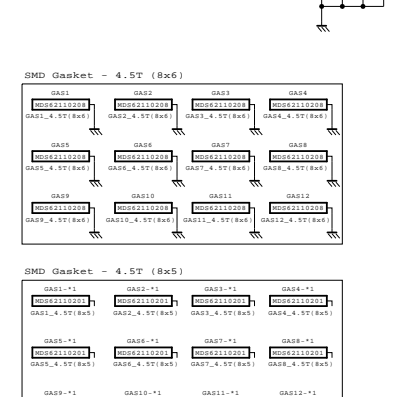
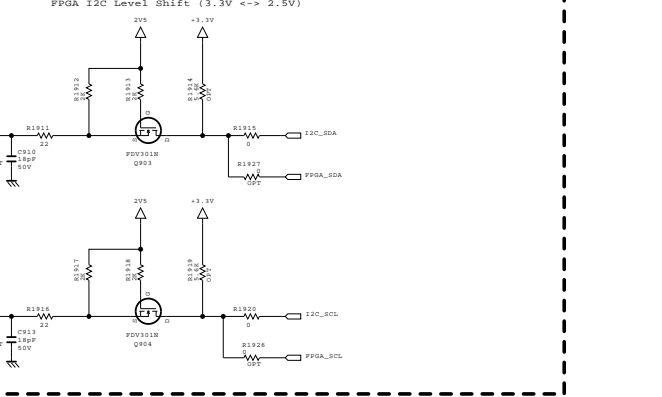
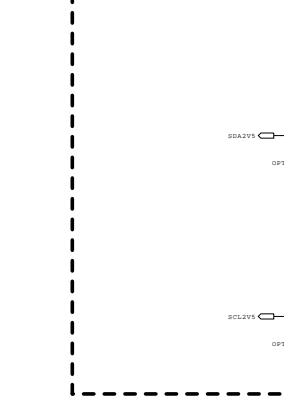
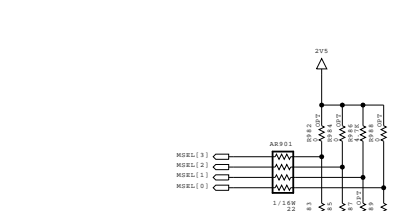
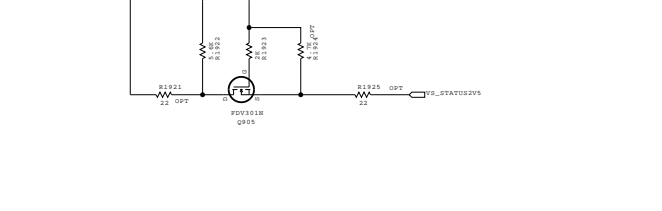
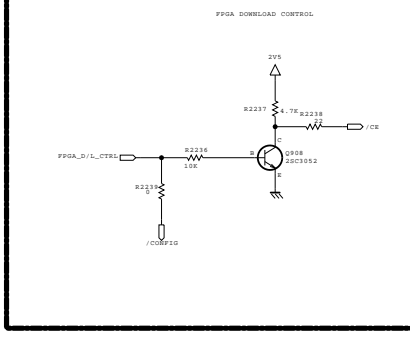
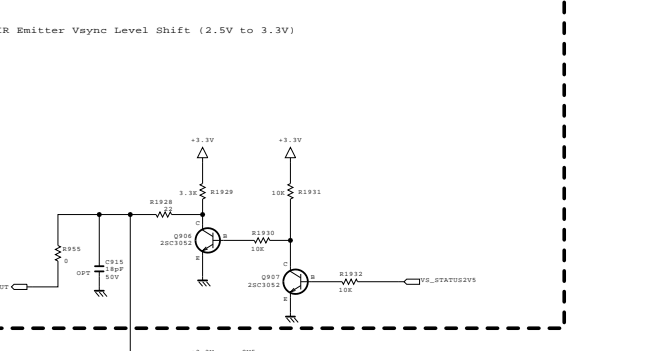
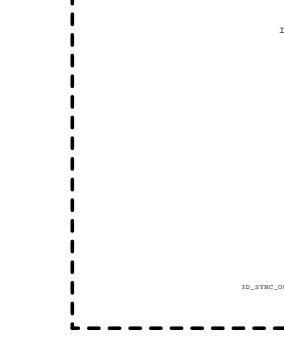
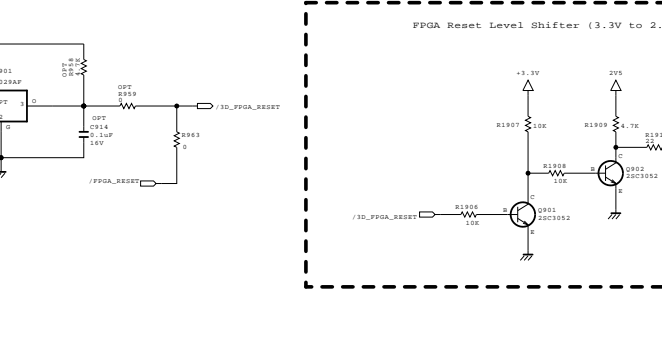
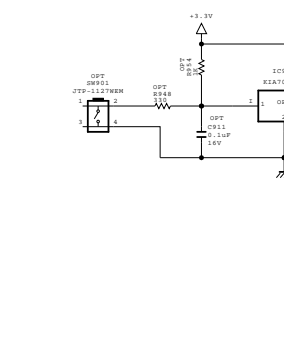
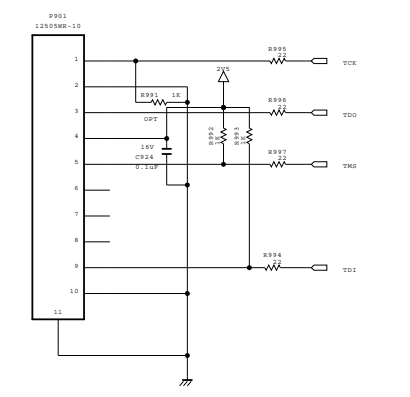
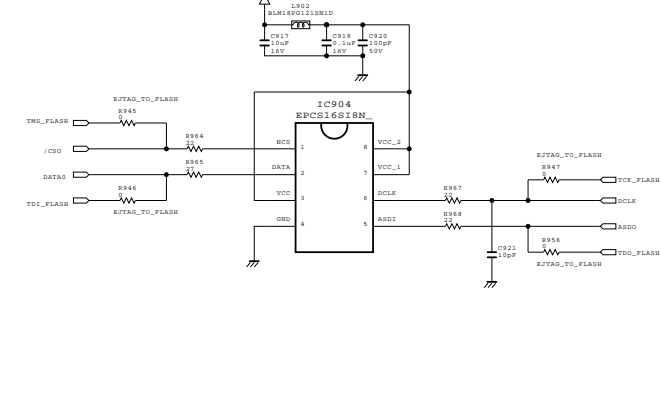
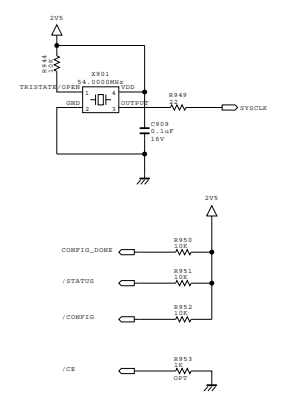
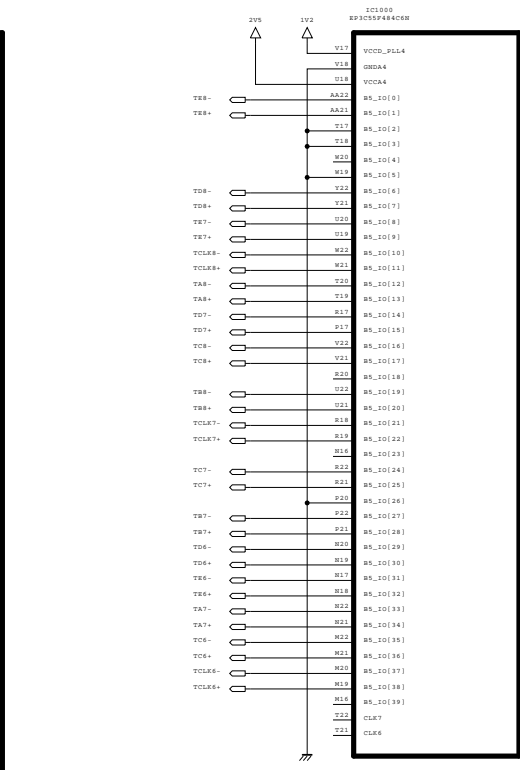
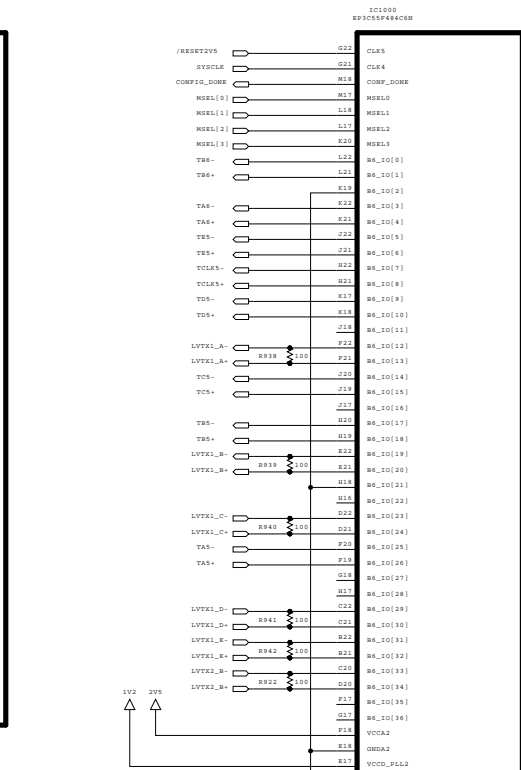
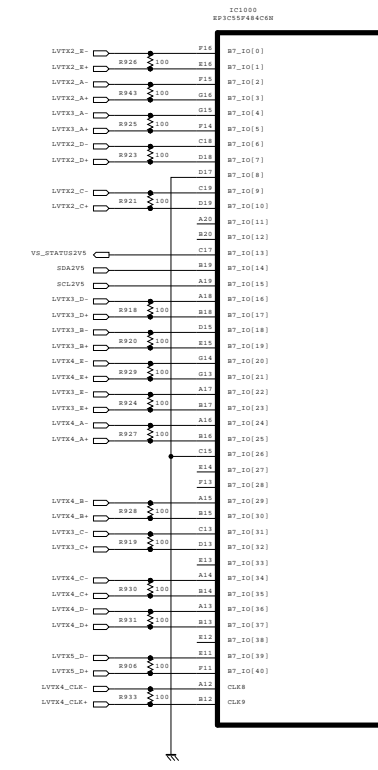
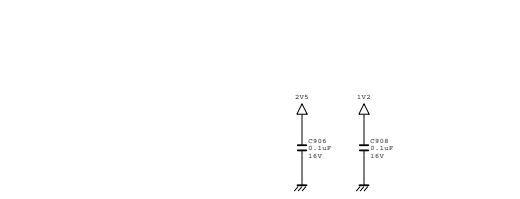
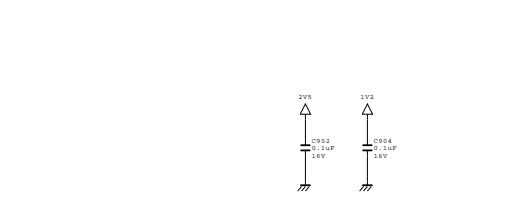
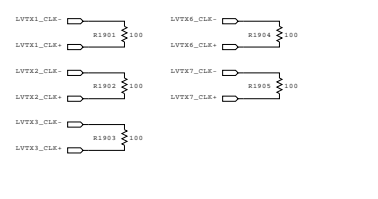
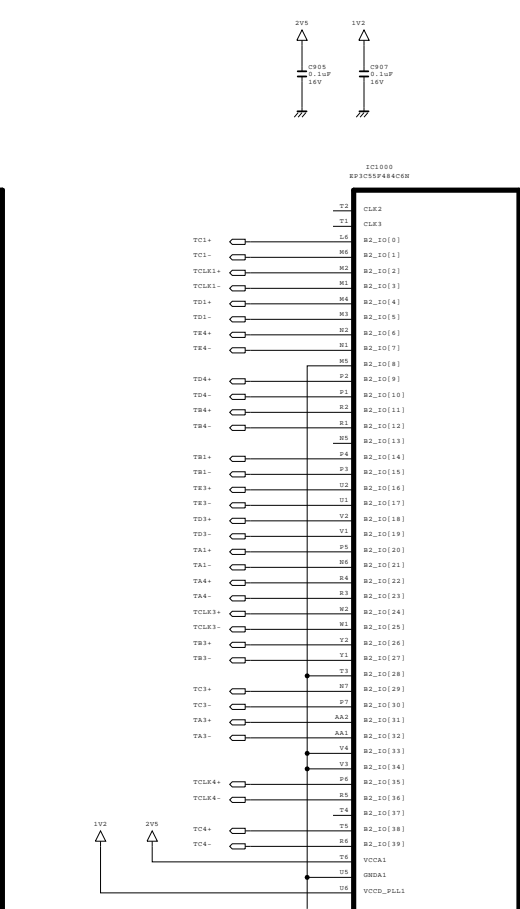
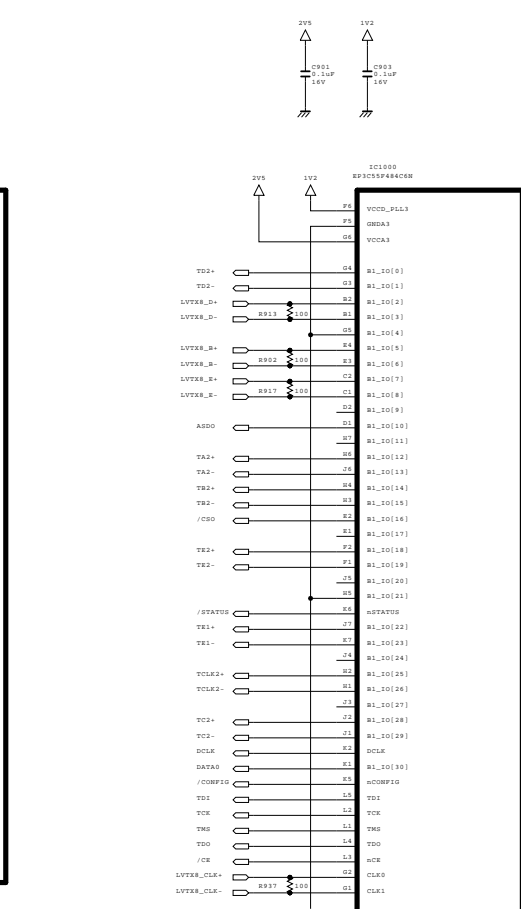
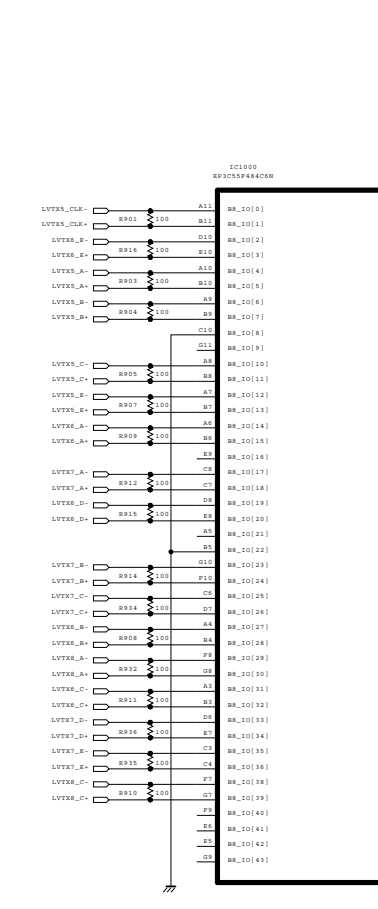

THE SYMBOL MARK OF THIS SCHEMATIC DIAGRAM INCORPORATES SPECIAL FEATURES IMPORTANT FOR PROTECTION FROM X-RADIATION. FILRE AND ELECTRICAL SHOCK HAZARDS, WHEN SERVICING IF IS ESSENTIAL THAT ONLY MANUFACTURES SPECIFIED PARTS BE USED FOR THE CRITICAL COMPONENTS IN THE SYMBOL MARK OF THE SCHEMATIC.

SECRET
LGElectronics

LG ELECTRONICS

MODEL	3D + 240 PRC + TCON BOARD	DATE	2009. 11. 13
BLOCK	EP3CS5_C6N (FPGA IC)	SHEET	9 / 10

