



website <http://www.lgservice.com>

LG

LG

Room Air Conditioner

SERVICE MANUAL

MODELS: AS-W0964DH0
AS-W1264DH0
AS-W1865DH0
AS-W0964GH0
AS-W1264GH0
AS-W1224DH0
AS-W1424DH0
AS-W1825DH0

CAUTION

- BEFORE SERVICING THE UNIT, READ THE SAFETY PRECAUTIONS IN THIS MANUAL.
- ONLY FOR AUTHORIZED SERVICE PERSONNEL.

TABLE OF CONTENTS

LG Model Name	3
Safety Precautions	5
Dimensions	10
Installation	14
Flaring work and connection of piping	16
Connecting the cable between indoor unit and outdoor unit	21
Checking the drainage and forming the pipings	23
Air purging	24
Test running	26
Functions	27
Operation	30
Disassembly	41
Troubleshooting Guide	44
Schematic Diagram	65
Product Specifications	73
Exploded View	75
Replacement Parts List	78

LG Model Name

2003

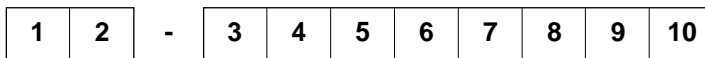

Code	Type	Code of Model	Meaning																																								
1	Producing Center, Refrigerant	A~Z	L: Chang-won R22 A: Chang-won R410A C: Chang-won R407C T: China K: Turkey R22 E: Turkey R410A H: Thailand N: India Z: Brazil D: Indonesia M: Mexico V: Vietnam S: Out Sourcing																																								
2	Product Type	A~Z	S: Split Type Air Conditioner																																								
3	Cooling/Heating/Inverter	A~Z	C: Cooling only H: Heat pump X: C/O + E/Heater Z: H/P + E/Heater V: AC Inverter C/O N: AC Inverter H/P Q: DC Inverter C/O W: DC Inverter H/P																																								
4, 5	Capacity	0~9	Cooling/Heating Capacity Ex. "09" → 9,000 Btu/h																																								
6	Electric Range	1~9 A~Z	1: 115V/60Hz, A: 220V, 50Hz, 3Phase 2: 220V/60Hz B: 208~230V, 60Hz, 3Phase 3: 208-230V/60Hz C: 575V, 50Hz, 3Phase 5: 200-220V/50Hz D: 440~460, 60Hz, 3Phase 6: 220-240V/50Hz E: 265V, 60Hz 7: 110V, 50/60Hz F: 200V, 50/60Hz 8: 380-415V/50Hz 9: 380-415V/60Hz																																								
7	Chassis	A~Z	Name of Chassis of Unit Ex. LSP → SP Chassis																																								
8	Look	A~Z	Look, Color (Artcool Model)																																								
9	Function	A~Z	<table border="1"> <tr><td>Basic</td><td>A</td></tr> <tr><td>Basic+4Way</td><td>B</td></tr> <tr><td>Plasma Filter</td><td>C</td></tr> <tr><td>Plasma Filter+4 Way</td><td>D</td></tr> <tr><td>Tele+LCD</td><td>E</td></tr> <tr><td>Tele+LCD+Nano plasma+4Way</td><td>F</td></tr> <tr><td>Nano Plasma F+(A/changeove)+A/clean+Low A</td><td>G</td></tr> <tr><td>Nano Plasma F+(A/changeove)+A/clean+4way+Low A</td><td>H</td></tr> <tr><td>Tele+LED+4way</td><td>I</td></tr> <tr><td>Internet</td><td>J</td></tr> <tr><td>Plasma F+4Way+Oxy generator</td><td>K</td></tr> <tr><td>Nano Plasma F+(A/changeove)+A/clean</td><td>L</td></tr> <tr><td>Nano Plasma F+(A/changeove)+A/clean+4way</td><td>M</td></tr> <tr><td>Nano Plasma F+(A/changeove)+A/clean+PTC</td><td>N</td></tr> <tr><td>Nano Plasma F+(A/changeove)+Autoclean+4way+PTC</td><td>P</td></tr> <tr><td>Nano Plasma F+(A/changeove)+A/clean+4way+Low A+PTC</td><td>Q</td></tr> <tr><td>Negative ION+A/Clean</td><td>R</td></tr> <tr><td>(Nano)Plasma+Negative ION+A/Clean</td><td>S</td></tr> <tr><td>4way+(Nano)Plasma F+Negative ION+Healthy dehumidification+A/Clean</td><td>T</td></tr> <tr><td>Nano Plasma F+4Way+(A/changeove)+A/clean+</td><td>U</td></tr> </table>	Basic	A	Basic+4Way	B	Plasma Filter	C	Plasma Filter+4 Way	D	Tele+LCD	E	Tele+LCD+Nano plasma+4Way	F	Nano Plasma F+(A/changeove)+A/clean+Low A	G	Nano Plasma F+(A/changeove)+A/clean+4way+Low A	H	Tele+LED+4way	I	Internet	J	Plasma F+4Way+Oxy generator	K	Nano Plasma F+(A/changeove)+A/clean	L	Nano Plasma F+(A/changeove)+A/clean+4way	M	Nano Plasma F+(A/changeove)+A/clean+PTC	N	Nano Plasma F+(A/changeove)+Autoclean+4way+PTC	P	Nano Plasma F+(A/changeove)+A/clean+4way+Low A+PTC	Q	Negative ION+A/Clean	R	(Nano)Plasma+Negative ION+A/Clean	S	4way+(Nano)Plasma F+Negative ION+Healthy dehumidification+A/Clean	T	Nano Plasma F+4Way+(A/changeove)+A/clean+	U
Basic	A																																										
Basic+4Way	B																																										
Plasma Filter	C																																										
Plasma Filter+4 Way	D																																										
Tele+LCD	E																																										
Tele+LCD+Nano plasma+4Way	F																																										
Nano Plasma F+(A/changeove)+A/clean+Low A	G																																										
Nano Plasma F+(A/changeove)+A/clean+4way+Low A	H																																										
Tele+LED+4way	I																																										
Internet	J																																										
Plasma F+4Way+Oxy generator	K																																										
Nano Plasma F+(A/changeove)+A/clean	L																																										
Nano Plasma F+(A/changeove)+A/clean+4way	M																																										
Nano Plasma F+(A/changeove)+A/clean+PTC	N																																										
Nano Plasma F+(A/changeove)+Autoclean+4way+PTC	P																																										
Nano Plasma F+(A/changeove)+A/clean+4way+Low A+PTC	Q																																										
Negative ION+A/Clean	R																																										
(Nano)Plasma+Negative ION+A/Clean	S																																										
4way+(Nano)Plasma F+Negative ION+Healthy dehumidification+A/Clean	T																																										
Nano Plasma F+4Way+(A/changeove)+A/clean+	U																																										
10	Serial No.	0~9	LG Model Development Serial No.																																								

* ARTCOOL COLOR

R	Mirror
W	White
B	Blue
D	Wood
M	Metal
C	Cherry

N	Walnut
A	Gogh
S	Sisley
Q	Quran
K	Mecca

2004~

1	2	-	3	4	5	6	7	8	9	10
---	---	---	---	---	---	---	---	---	---	----

Code	Type	Code of Model	Meaning		
1	Producing Center, Refrigerant	A~Z	L Chang_won R22 N India		
			A Chang_won R410A Z Brazil		
			C Chang_won R407C D Indonesia		
			T China X Mexico		
			K Turkey R22 V Vietnam		
			E Turkey R410A S Out sourcing		
			H Thailand		
2	Product Type	A~Z	S: Split Type Air Conditioner		
3	Cooling/Heating/Inverter	A~Z	C: Cooling only V: AC Inverter C/O H: Heat pump N: AC Inverter H/P X: C/O + E/Heater Q: DC Inverter C/O Z: H/P + E/Heater W: DC Inverter H/P		
4, 5	Capacity	0~9	Cooling/Heating Capacity Ex. "09" → 9,000 Btu/h		
6	Electric Range	1~9	1: 115V/60Hz, A: 220V, 50Hz, 3Phase		
		A~Z	2: 220V/60Hz B: 208~230V, 60Hz, 3Phase		
			3: 208-230V/60Hz C: 575V, 50Hz, 3Phase		
			5: 200-220V/50Hz D: 440~460, 60Hz, 3Phase		
			6: 220-240V/50Hz E: 265V, 60Hz		
			7: 110V, 50/60Hz F: 200V, 50/60Hz		
			8: 380-415V/50Hz		
	9: 380-415V/60Hz				
7	Chassis	A~Z	Name of Chassis of Unit Ex. LSP → SP Chassis		
			CHASSIS	Look	Division
			S4/S5	D	Panel Type(Deluxe)
			S6	K	Fighting 'Look'
			SQ	L	(LG1)
			SR	G	(LG2)-SEMI PANEL
8	Look	A~Z	Look, Color (Artcool Model)		
			ST	M	OEM1
				N	OEM2
				D	Panel Type(Deluxe)
				P	LG3
9	Function	A~Z	Basic	A	
			Basic+4Way	B	
			Plasma Filter	C	
			Plasma Filter+4 Way	D	
			Tele+LCD	E	
			Tele+LCD+Nano plasma+4Way	F	
			NBF F+(A/changeove)+A/clean+Low A	G	
			NBF F+(A/changeove)+A/clean+4way+Low A	H	
			Tele+LED+4way	I	
			Internet	J	
			Plasma F+4Way+Oxy generator	K	
			NBF F+(A/changeove)+A/clean	L	
			NBF F+(A/changeove)+A/clean+4way	M	
			NBF F+(A/changeove)+A/clean+PTC	N	
			NBF F+(A/changeove)+Autoclean+4way+PTC	P	
			NBF F+(A/changeove)+A/clean+4way+Low A+PTC	Q	
			(Nano)Plasma+ION+A/Clean	S	
			4way+(Nano)Plasma F+Negative ION+Healthy dehumidification+A/Clean	T	
			Nano Plasma F+4Way+(A/changeove)+A/clean+Oxy generator	U	
			4way+(Nano)Plasma F+Negative ION+Healthy dehumidification+A/Clean+Oxy generator	V	
Dry contact	W				
Wire remocon	8				
10	Serial No.	0~9	LG Model Development Serial No.		
			* ARTCOOL COLOR		
			R	Mirror	
			W	White	
			B	Blue	
			D	Wood	
			M	Metal	
C	Cherry				

Safety Precautions



To prevent injury to the user or other people and property damage, the following instructions must be followed.

■ Incorrect operation due to ignoring instruction will cause harm or damage. The seriousness is classified by the following indications.

⚠ WARNING This symbol indicates the possibility of death or serious injury.

⚠ CAUTION This symbol indicates the possibility of injury or damage to properties only.

■ Meanings of symbols used in this manual are as shown below.

	Be sure not to do.
	Be sure to follow the instruction.

⚠ WARNING

■ Installation

Do not use damaged power cords, plugs, or a loose socket.

- There is risk of fire of electric shock.

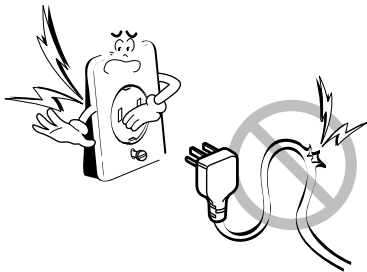

Always use the power plug and socket with the ground terminal.

- There is risk of electric shock.

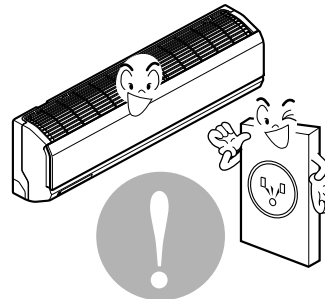

Install the panel and the cover of control box securely.

- There is risk of fire of electric shock.

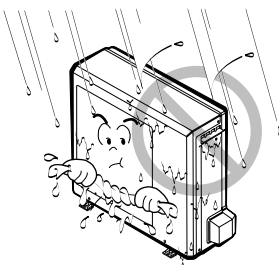

Do not modify or extend the power cord.

- No grounding may cause electric shock.

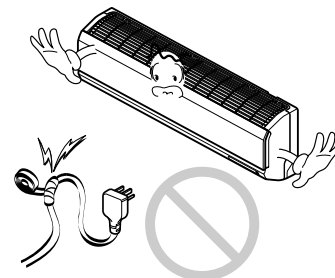

For re-installation of the installed product, always contact a dealer or an authorized service center.

- There is risk of fire, electric shock, explosion, or injury.

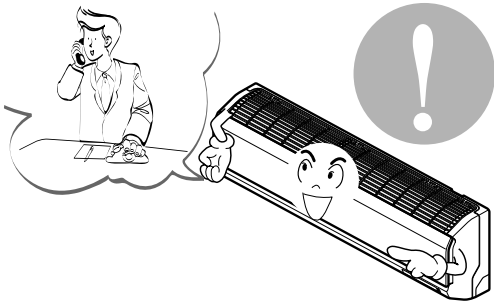

Do not install, remove, or re-install the unit by yourself.

- There is risk of fire, electric shock, explosion, or injury.

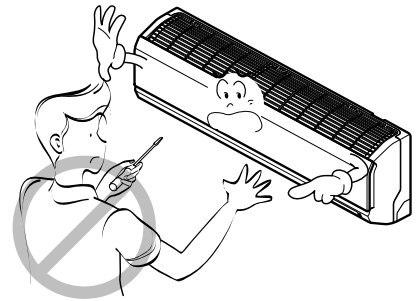

Be cautious when unpacking and installing the product.

- Sharp edges could cause injury. Be especially careful of the case edges and the fins on the condenser and evaporator.

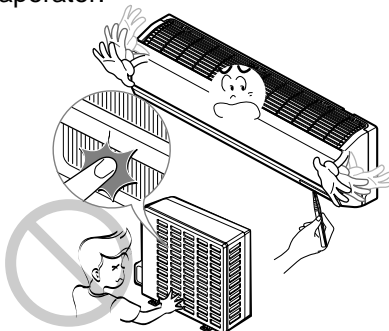

For installation, always contact the dealer or an Authorized service center

- There is risk of fire, electric shock, explosion, or injury.

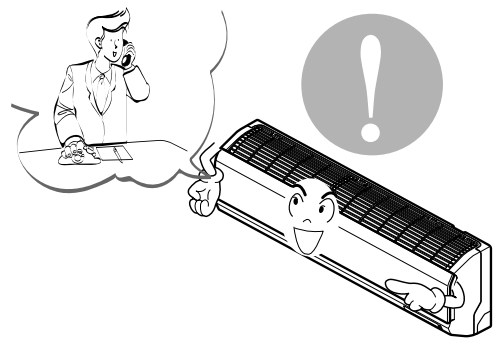

Do not install the product on a defective installation stand.

- It may cause injury, accident, or damage to the product.

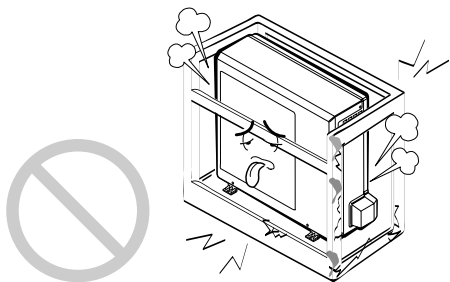

Be sure the installation area does not deteriorate with age.

- If the base collapses, the air conditioner could fall with it, causing property damage, product failure, and personal injury.

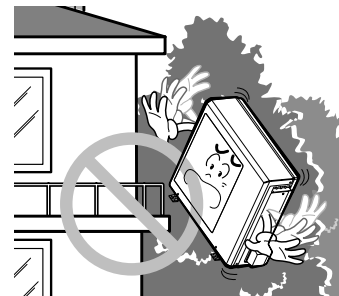

■ Operation

Do not turn the air-conditioner ON or OFF by plugging or unplugging the power plug.

- There is risk of fire or electrical shock.



Use a dedicated outlet for this appliance.

- There is risk of fire or electrical shock.

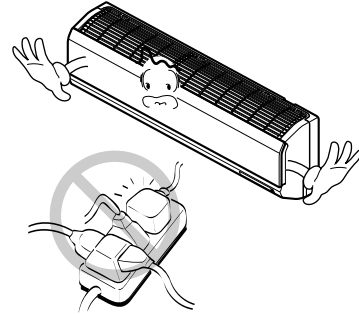

Grasp the plug to remove the cord from the outlet. Do not touch it with wet hands.

- There is risk of fire or electrical shock.

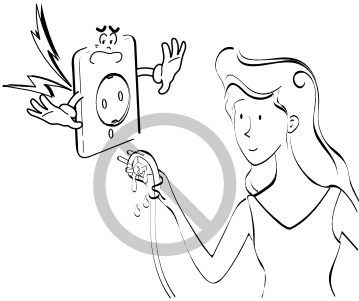

Do not place a heater or other appliances near the power cable.

- There is risk of fire and electric shock.

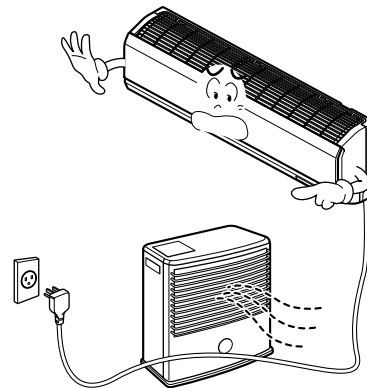

Do not allow water to run into electrical parts.

- There is risk of fire, failure of the product, or electric shock.

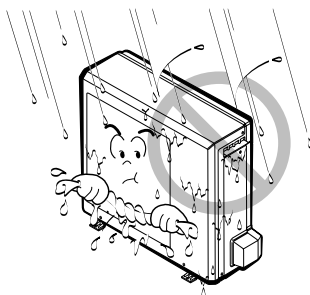

Do not store or use flammable gas or combustibles near the air conditioner.

- There is risk of fire or failure of product.

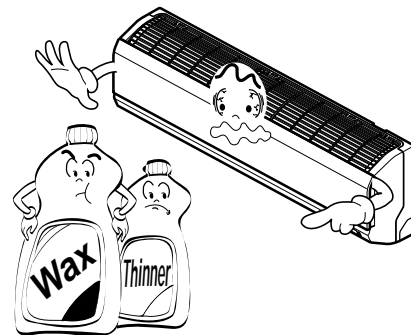

Unplug the unit if strange sounds, odors, or smoke comes from it.

- There is risk of electric shock or fire.

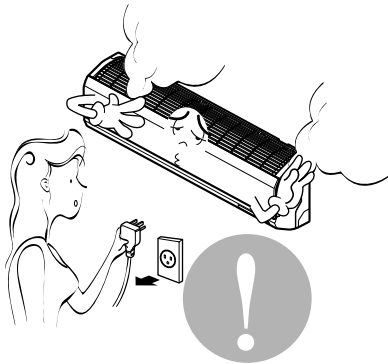

Be cautious that water could not enter the product.

- There is risk of fire, electric shock, or product damage.

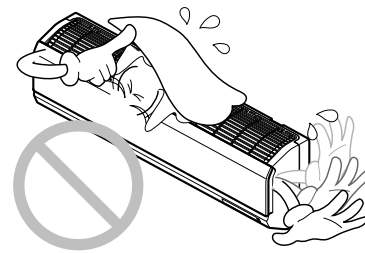

CAUTION

Installation

Always check for gas (refrigerant) leakage after installation or repair of product.

- Low refrigerant levels may cause failure of product.

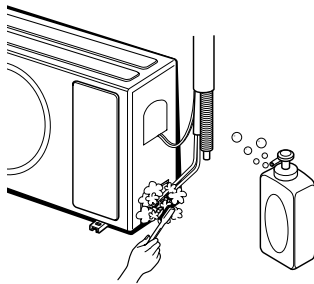

Install the drain hose to ensure that water is drained away properly.

- A bad connection may cause water leakage.

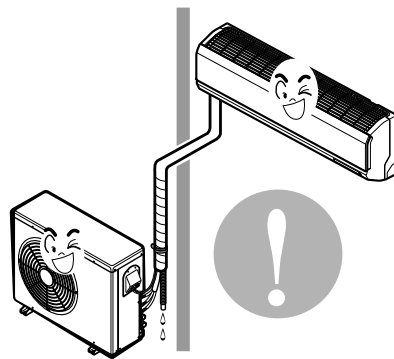

Keep level even when installing the product.

- To avoid vibration or water leakage.

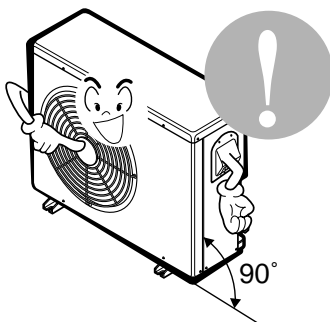

Use two or more people to lift and transport the air conditioner.

- Avoid personal injury.

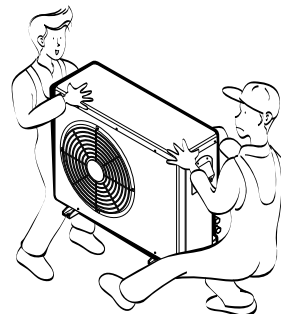

■ Operation

Use a soft cloth to clean. Do not use harsh detergents, solvents, etc.

- There is risk of fire, electric shock, or damage to the plastic parts of the product.

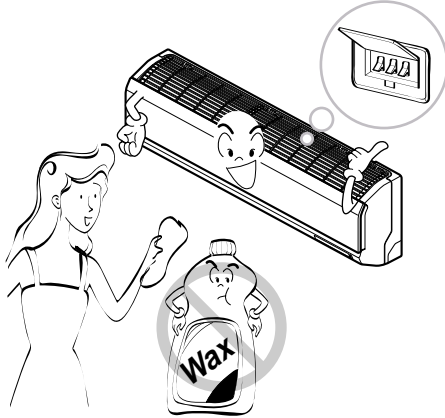

Do not touch the metal parts of the product when removing the air filter. They are very sharp!

- There is risk of personal injury.

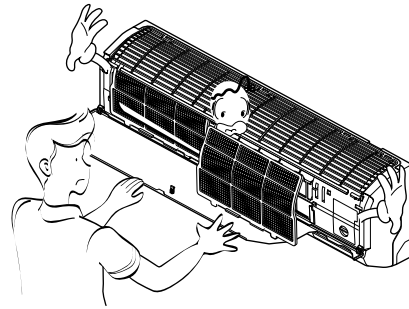

Do not step on or put anything on the product. (outdoor units)

- There is risk of personal injury and failure of product.



Do not insert hands or other objects through the air inlet or outlet while the air conditioner is plugged in.

- There are sharp and moving parts that could cause personal injury.

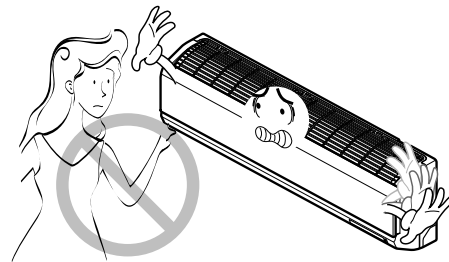

Dimensions

Symbols Used in this Manual



This symbol alerts you to the risk of electric shock.



This symbol alerts you to hazards that could cause harm to the air conditioner.

NOTICE This symbol indicates special notes.

Indoor Unit

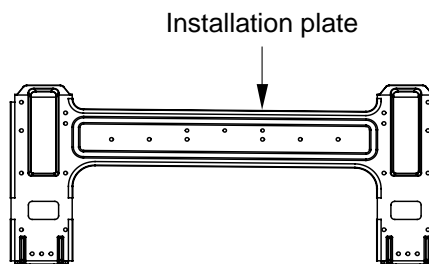
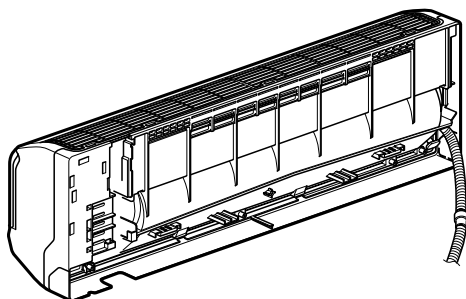
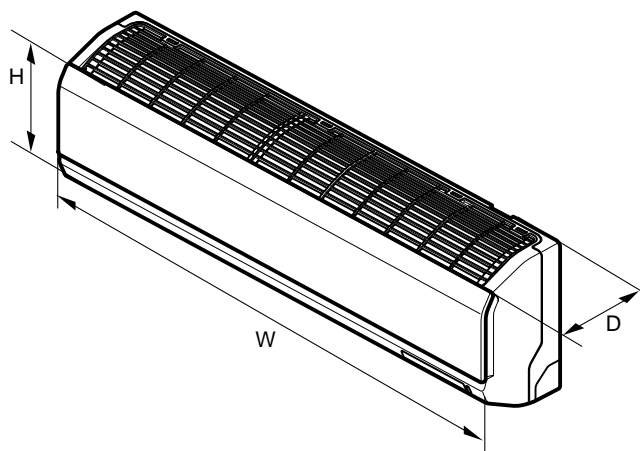

Dimension		Model	7k, 9k, 12k, 14k Btu Series
W	mm		840
H	mm		270
D	mm		153

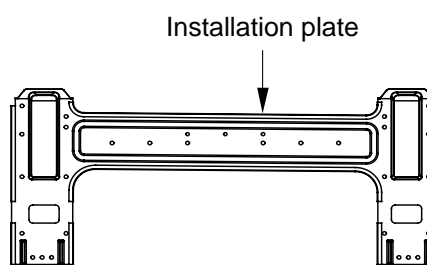
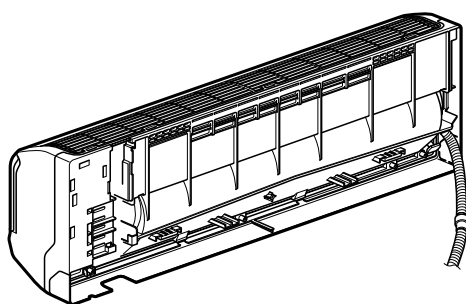
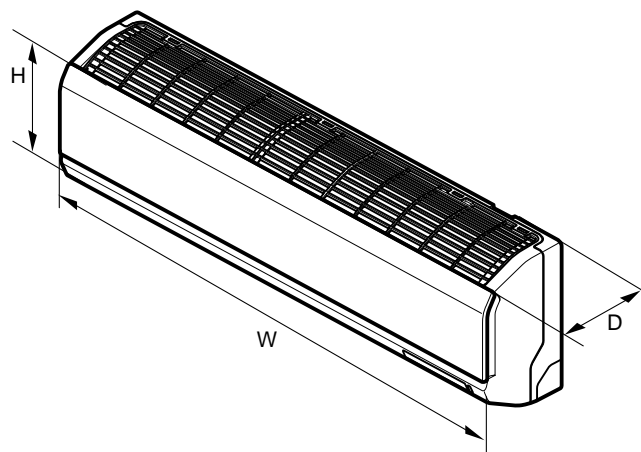

Dimension		Model	18k, 24k Btu Series
W	mm		1090
H	mm		300
D	mm		178

Outdoor Unit

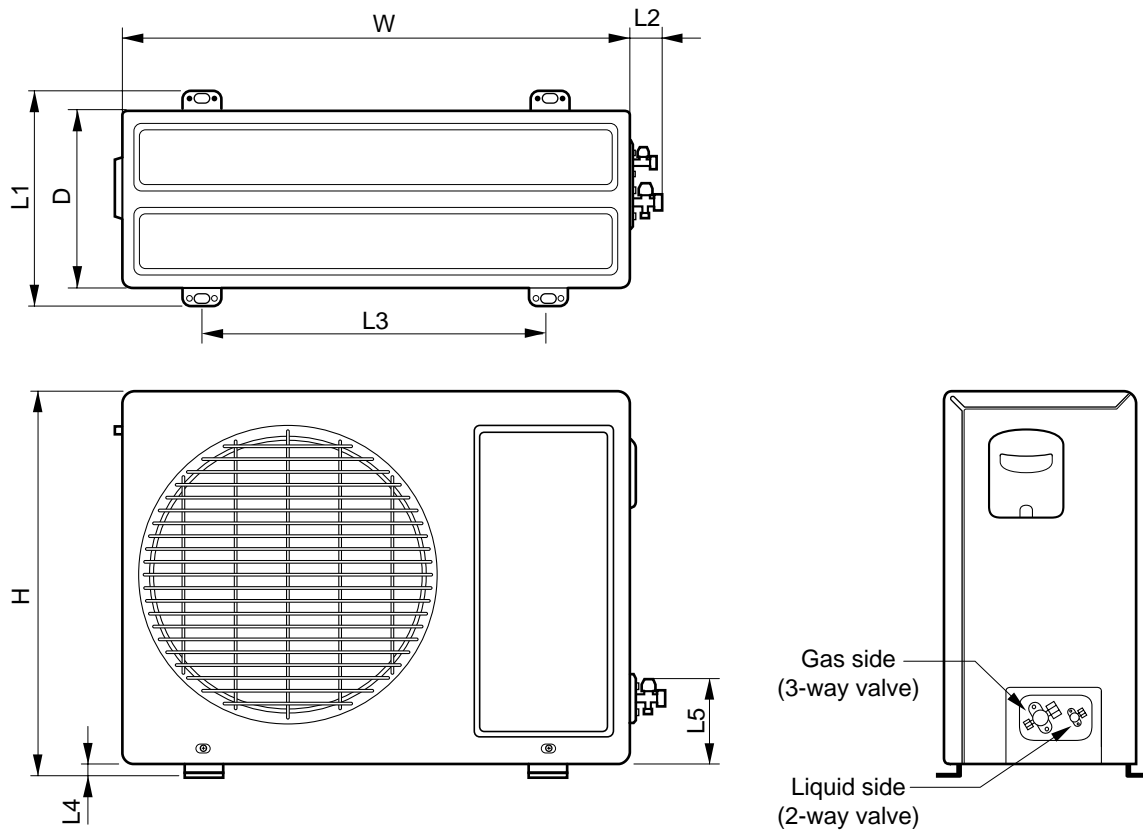

DIM	MODEL	7k, 9k, 12k, 14k Btu Series
	unit	
W	mm	770
H	mm	540
D	mm	245
L1	mm	285
L2	mm	65
L3	mm	518
L4	mm	10
L5	mm	100

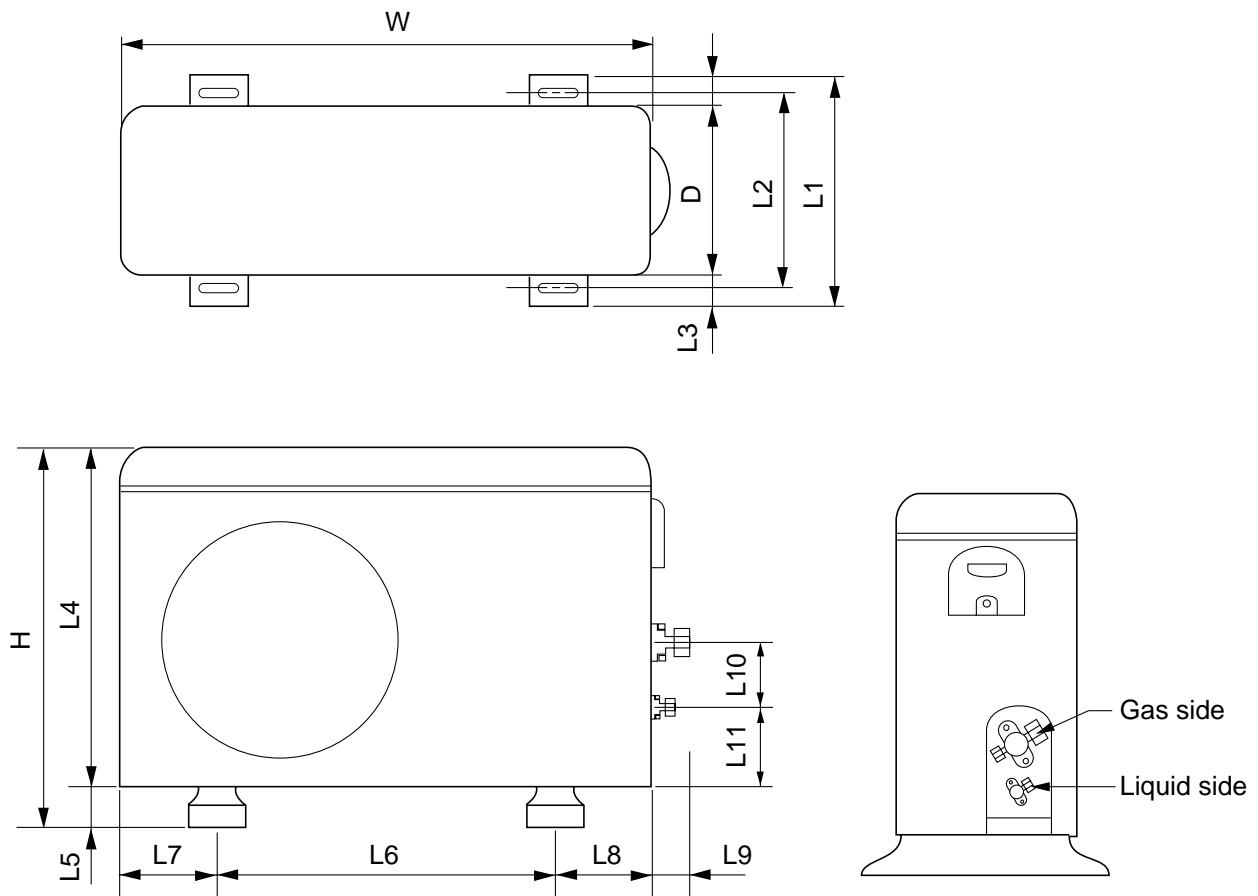

MODEL		18k, 24k Btu Series
DIM		
W	mm	870
H	mm	655
D	mm	320
L1	mm	370
L2	mm	340
L3	mm	25
L4	mm	630
L5	mm	25
L6	mm	546
L7	mm	162
L8	mm	162
L9	mm	54
L10	mm	74.5
L11	mm	79

Installation

Selection of the Best Location

Indoor unit

- Do not have any heat or steam near the unit.
- Select a place where there are no obstacles in front of the unit.
- Make sure that condensation drainage can be conveniently routed away.
Do not install near a doorway.
- Ensure that the space around the left and right of the unit is more than "A". The unit should be installed as high on the wall as possible, allowing a minimum of "B" from ceiling.
- Use a stud finder to locate studs to prevent unnecessary damage to the wall.

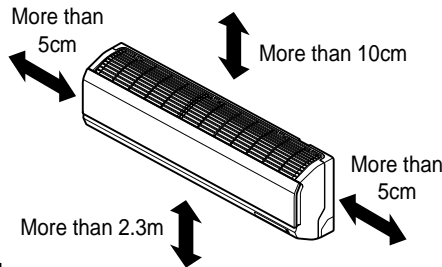

CAUTION

Install the indoor unit on the wall where the height from the floors more than 2.3 meters.

Grade	Clearance(cm)	
	A	B
5K~28K	10	5
30K~38K	30	12

Outdoor unit

- If an awning is built over the unit to prevent direct sunlight or rain exposure, make sure that heat radiation from the condenser is not restricted.
- Ensure that the space around the back and sides is more than 10cm. The front of the unit should have more than 70cm of space.
- Do not place animals and plants in the path of the warm air.
- Take the air conditioner weight into account and select a place where noise and vibration are minimum.
- Select a place so that the warm air and noise from the air conditioner do not disturb neighbors.

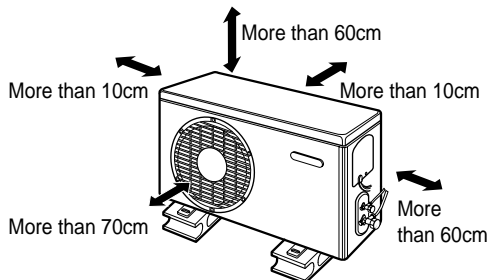

Rooftop Installations:

- If the outdoor unit is installed on a roof structure, be sure to level the unit. Ensure the roof structure and anchoring method are adequate for the unit location.
- Consult local codes regarding rooftop mounting.

Piping Length and Elevation

Capacity (Btu/h)	Pipe Size		Standard Length (m)	Max. Elevation B (m)	Max. Length A (m)	Additional Refrigerant (g/m)
	GAS	LIQUID				
5k~14k	3/8"(Ø9.52)	1/4"(Ø6.35)	4 or 7.5	7	15	20
	1/2"(Ø12.7)	1/4"(Ø6.35)	4 or 7.5	7	15	20
18k~28k	1/2"(Ø12.7)	1/4"(Ø6.35)	4 or 7.5	15	30	20
	5/8"(Ø15.88)	1/4"(Ø6.35)	4 or 7.5	15	30	20
30k~38k	5/8"(Ø15.88)	3/8"(Ø9.52)	4 or 7.5	15	30	30
	3/4"(Ø19.05)	3/8"(Ø9.52)	7.5	15	30	50

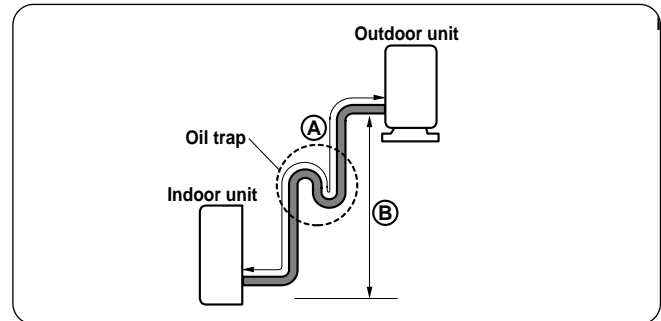
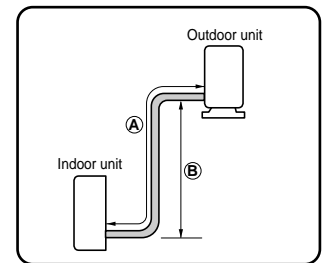
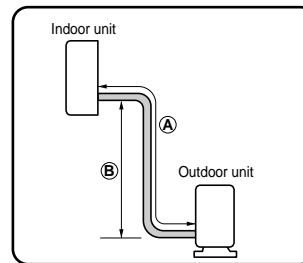

If case more than 5m

CAUTION

- Capacity is based on standard length and maximum allowance length is on the basis of reliability.
- Oil trap should be installed every 5~7 meters.

How to Fix Installation Plate

The wall you select should be strong and solid enough to prevent vibration

1. Mount the installation plate on the wall with four type A screws. If mounting the unit on a concrete wall, use anchor bolts.

- Mount the installation plate horizontally by aligning the centerline using a level.

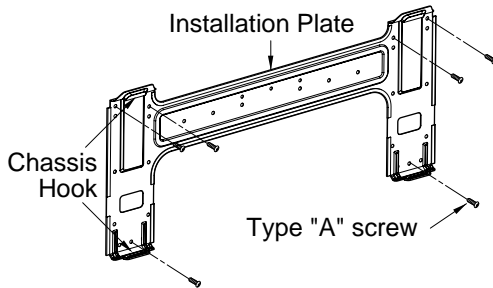

2. Measure the wall and mark the centerline. It is also important to use caution concerning the location of the installation plate—routing of the wiring to power outlets is through the walls typically. Drilling the hole through the wall for piping connections must be done safely.

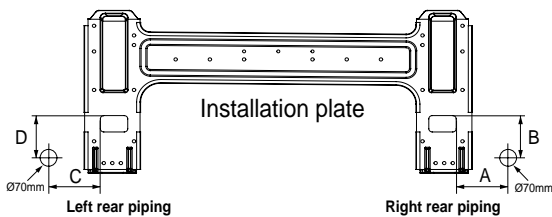

CHASSIS (Grade)	Distance (mm)			
	A	B	C	D
7k, 9k, 12k, 14k	75	65	105	65
18k, 24k	105	65	260	65

Drill a Hole in the Wall

- Drill the piping hole with a $\varnothing 70\text{mm}$ hole core drill. Drill the piping hole at either the right or the left with the hole slightly slanted to the outdoor side.

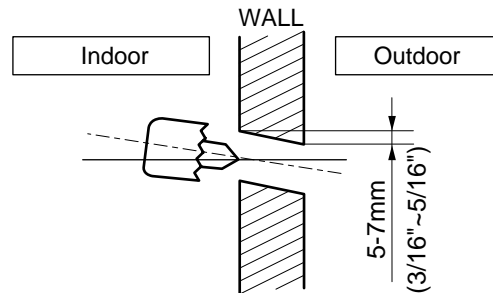

- Open the Front Grille.
- Pass Telephone Control Cord Wire through the hole which the power cord goes through.
- Connect Telephone Control Cord Wire to the phone jack of telephone PCB of Control Box.
- Fix Telephone Control Cord Wire inside Control box so as not to disconnect.
- Close the Front Grille.

Drain hose junction

- Remove the rubber stopple in the desired drain direction.
- Insert drain hose into the handle of drain pan, and join drain hose and connecting hose according to the figure by.

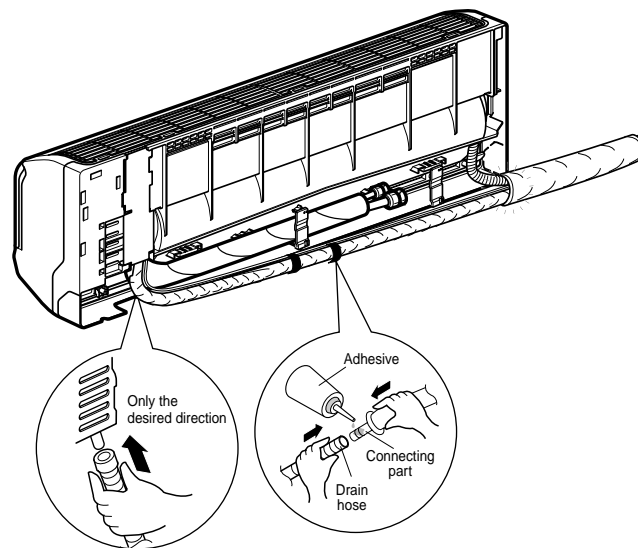

Flaring work and connection of piping

Flaring work

Flaring work

Main cause for refrigerant leakage is due to defect in the flaring work. Carry out correct flaring work using the following procedure.

Cut the pipes and the cable.

- Use the piping kit accessory or pipes purchased locally.
- Measure the distance between the indoor and the outdoor unit.
- Cut the pipes a little longer than the measured distance.
- Cut the cable 1.5m longer than the pipe length.

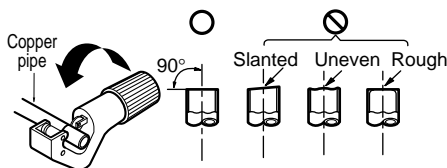

Burr removal

- Completely remove all burrs from the cut cross section of pipe/tube.
- Put the end of the copper tube/pipe in a downward direction as you remove burrs in order to avoid dropping burrs into the tubing.

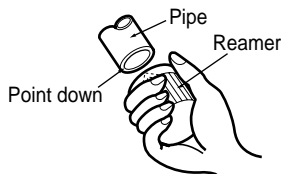

Putting nut on

- Remove flare nuts attached to indoor and outdoor unit, then put them on pipe/tube having completed burr removal. (not possible to put them on after flaring work)

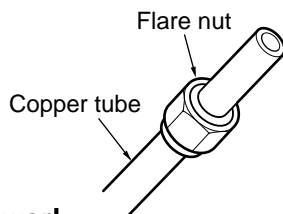

Flaring work

- Firmly hold copper pipe in a die in the dimension shown in the table above.

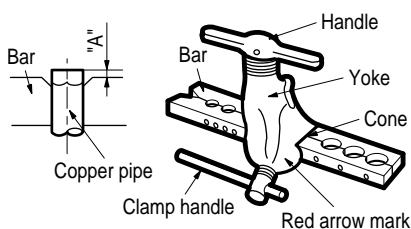

- Carry out flaring work using flaring tool as shown below.

Outside diameter		A
mm	inch	mm
Ø6.35	1/4	0~0.5
Ø9.52	3/8	0~0.5
Ø12.7	1/2	0~0.5
Ø15.88	5/8	0~1.0
Ø19.05	3/4	1.0~1.3

Check

- Compare the flared work with figure below.
- If flare is noted to be defective, cut off the flared section and re-flare it.

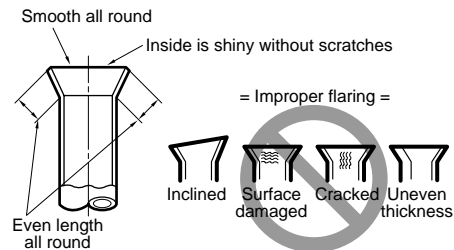

Connection of piping -- Indoor

- Preparing the indoor unit's piping and drain hose for installation through the wall.
- Remove the plastic tubing retainer(see illustration below) and pull the tubing and drain hose away from chassis.
- Replace the plastic tubing holder in the original position.(Optional)

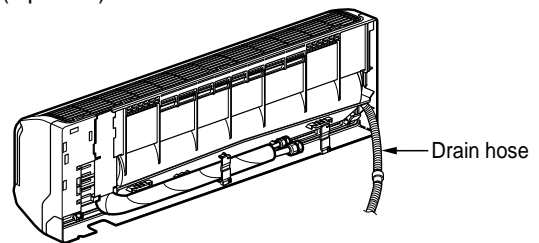

CAUTION

When install, make sure that the remaining parts must be removed clearly so as not to damage the piping and drain hose, especially power cord and connecting cable.

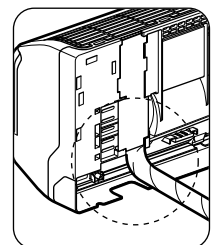

For right rear piping

Route the indoor tubing and the drain hose in the direction of rear right.

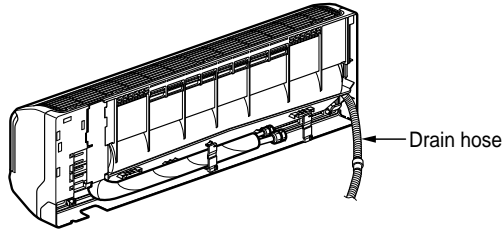

Insert the connecting cable into the indoor unit from the outdoor unit through the piping hole.

- Do not connect the cable to the indoor unit.
- Make a small loop with the cable for easy connection later.

Tape the tubing, drain hose, and the connecting cable. Be sure that the drain hose is located at the lowest side of the bundle. Locating at the upper side can cause drain pan to overflow inside the unit.

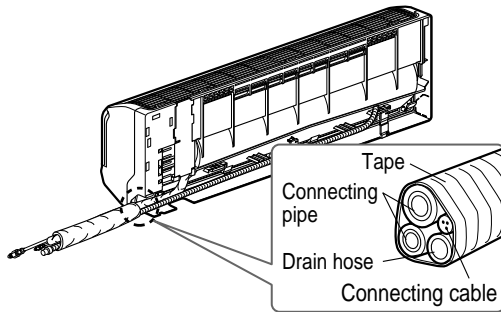

NOTE: If the drain hose is routed inside the room, insulate the hose with an insulation material* so that dripping from "sweating"(condensation) will not damage furniture or floors.

*Foamed polyethylene or equivalent is recommended.

Indoor unit installation

- Hook the indoor unit onto the upper portion of the installation plate.(Engage the two hooks of the rear top of the indoor unit with the upper edge of the installation plate.) Ensure that the hooks are properly seated on the installation plate by moving it left and right.

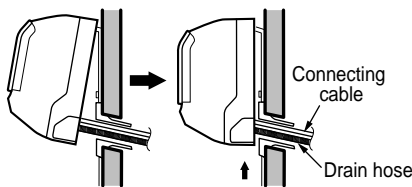

Press the lower left and right sides of the unit against the installation plate until the hooks engage into their slots(clicking sound).

Connecting the pipings to the indoor unit and drain hose to drain pipe.

- Align the center of the pipes and sufficiently tighten the flare nut by hand.

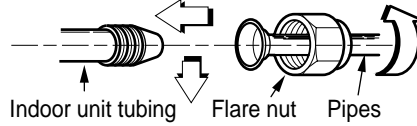

- Tighten the flare nut with a wrench.

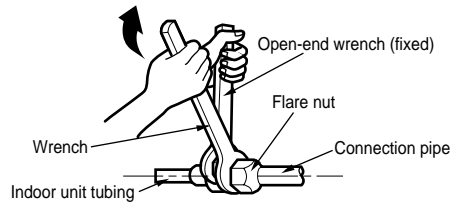

Outside diameter		Torque kg-m
mm	inch	
Ø6.35	1/4	1.8
Ø9.52	3/8	4.2
Ø12.7	1/2	5.5
Ø15.88	5/8	6.6
Ø19.05	3/4	6.6

- When extending the drain hose at the indoor unit, install the drain pipe.

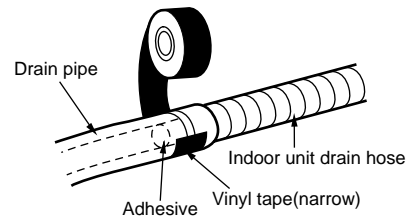

Wrap the insulation material around the connecting portion.

- Overlap the connection pipe insulation material and the indoor unit pipe insulation material. Bind them together with vinyl tape so that there is no gap.

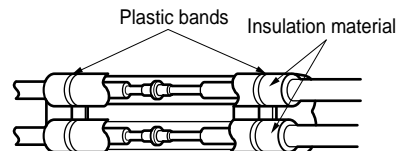

- Wrap the area which accommodates the rear piping housing section with vinyl tape.

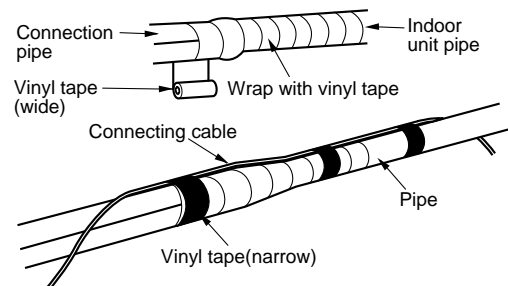

Flaring work and connection of piping

- Bundle the piping and drain hose together by wrapping them with vinyl tape for enough to cover where they fit into the rear piping housing section.

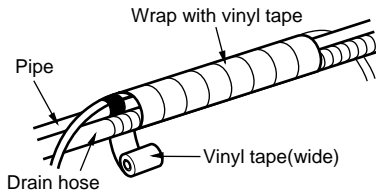

For left rear piping

Route the indoor tubing and the drain hose to the required piping hole position.

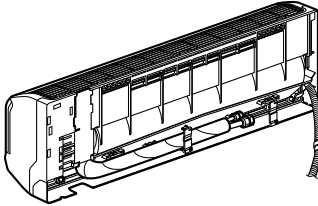

Insert the piping, drain hose, and the connecting cable into the piping hole.

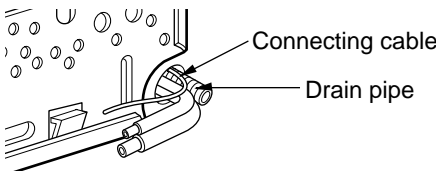

Insert the connecting cable into the indoor unit.

- Don't connect the cable to the indoor unit.
- Make a small loop with the cable for easy connection later.

Tape the drain hose and the connecting cable.

- Connecting cable

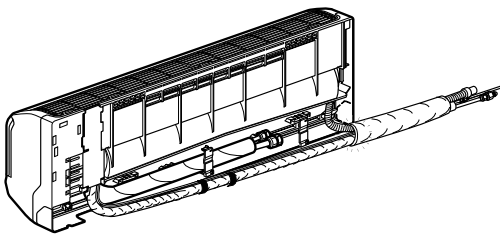

Indoor unit installation

- Hang the indoor unit from the hooks at the top of the installation plate.
- Insert the spacer etc. between the indoor unit and the installation plate and separate the bottom of the indoor unit from the wall.

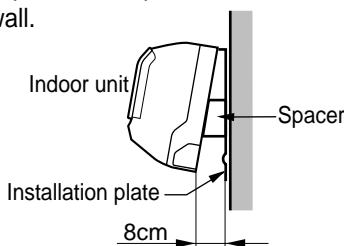

Connecting the pipings to the indoor unit and the drain hose to drain pipe.

- Align the center of the pipes and sufficiently tighten the flare nut by hand.

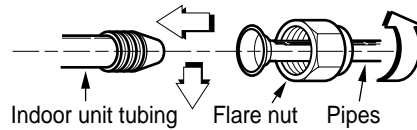

- Tighten the flare nut with a wrench.

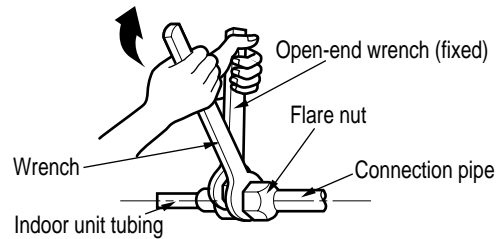

Outside diameter		Torque kg·m
mm	inch	
Ø6.35	1/4	1.8
Ø9.52	3/8	4.2
Ø12.7	1/2	5.5
Ø15.88	5/8	6.6
Ø19.05	3/4	6.6

- When extending the drain hose at the indoor unit, install the drain pipe.

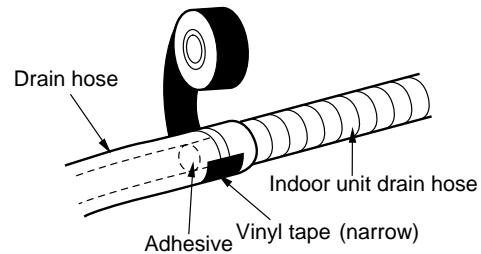

Wrap the insulation material around the connecting portion.

- Overlap the connection pipe heat insulation and the indoor unit pipe heat insulation material. Bind them together with vinyl tape so that there is no gap.

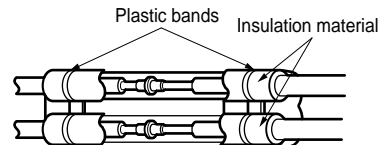

- Wrap the area which accommodates the rear piping housing section with vinyl tape.

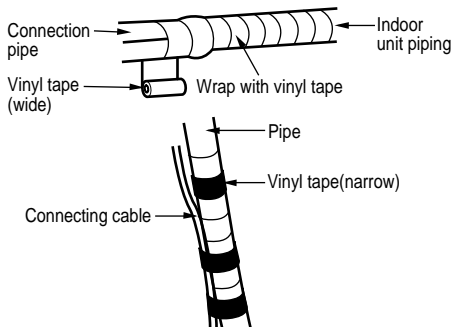

- Bundle the piping and drain hose together by wrapping them with cloth tape over the range within which they fit into the rear piping housing section.

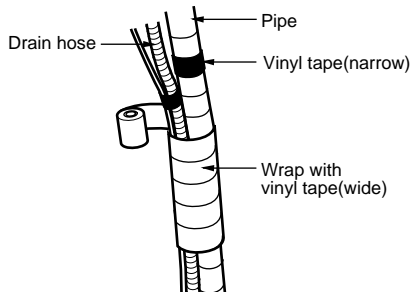

Reroute the pipings and the drain hose across the back of the chassis.

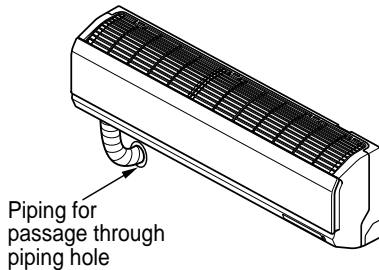

Set the pipings and the drain hose to the back of the chassis with the tubing holder.

- Hook the edge of tubing holder to tap on chassis and push the bottom of tubing holder to be engaged at the bottom of chassis.

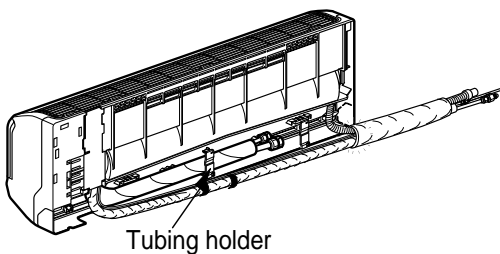

Indoor unit installation

- Remove the spacer.
- Ensure that the hooks are properly seated on the installation plate by moving it left and right.

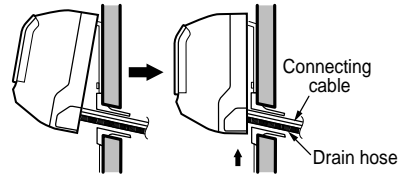

Press the lower left and right sides of the unit against the installation plate until the hooks engage into their slots (clicking sound).

CAUTION

Installation Information (For left piping)

- Good case
For left piping. Follow the instruction below.

- Press on the upper side of clamp. (A)

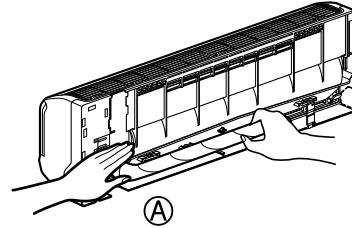

- Unfold the tubing to downward slowly. (B)

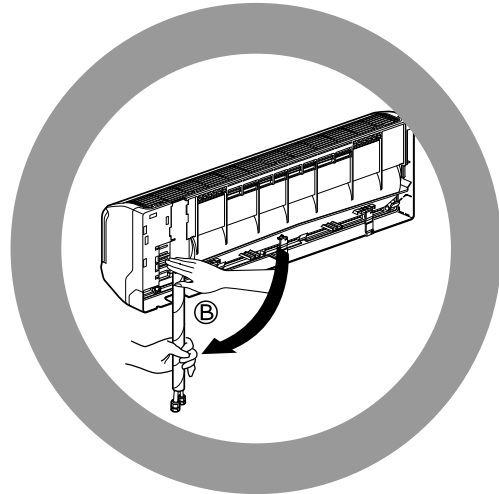

- Bend the tubing to the left side of chassis.

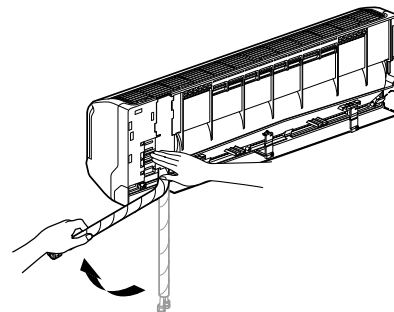

CAUTION

- Bad case
- Following bending type from right to left could cause problem of pipe damage.

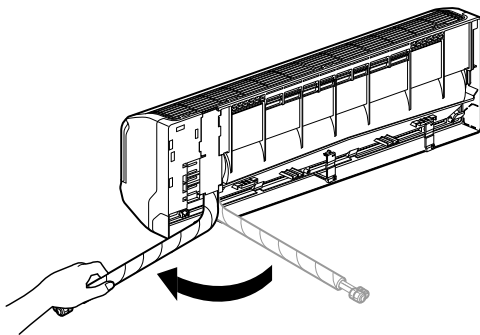
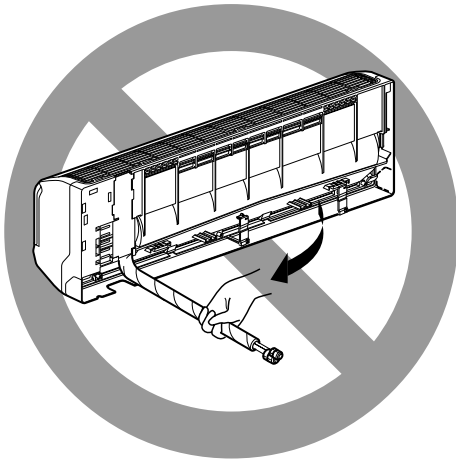
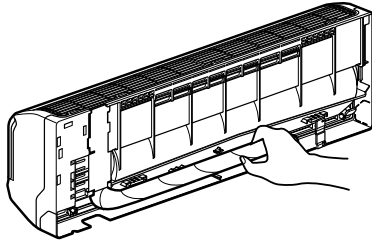

Connection of the pipes-Outdoor

Align the center of the pipings and sufficiently tighten the flare nut by hand.

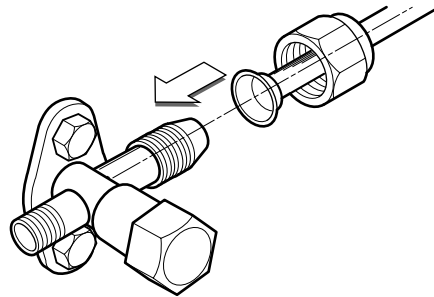

Finally, tighten the flare nut with torque wrench until the wrench clicks.

- When tightening the flare nut with torque wrench, ensure the direction for tightening follows the arrow on the wrench.

Outside diameter		Torque
mm	inch	kg-m
Ø6.35	1/4	1.8
Ø9.52	3/8	4.2
Ø12.7	1/2	5.5
Ø15.88	5/8	6.6
Ø19.05	3/4	6.6

Outdoor unit

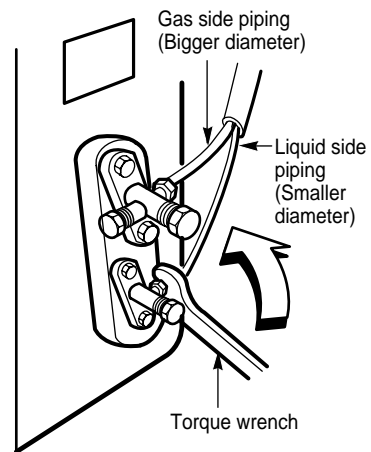

Connecting the cable between indoor unit and outdoor unit

Connect the cable to the Indoor unit.

Connect the cable to the indoor unit by connecting the wires to the terminals on the control board individually according to the outdoor unit connection. (Ensure that the color of the wires of the outdoor unit and the terminal No. are the same as those of the indoor unit.)

⚠ CAUTION

- The above circuit diagram is subject to change without notice.
- The earth wire should be longer than the common wires.
- When installing, refer to the circuit diagram behind the panel front of the indoor unit.
- Connect the wires firmly so that they may not be pulled out easily.
- Connect the wires according to color codes, referring to the wiring diagram.

⚠ CAUTION

If a power plug is not used, provide a circuit breaker between power source and the unit as shown by.

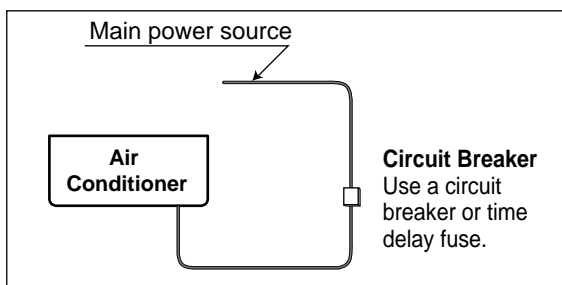

⚠ CAUTION

The power cord connected to the "A" unit should be selected according to the following specifications (Type "B" approved by HAR or SAA).

(mm²)

NORMAL CROSS SECTIONAL AREA	Grade			
	7k	9k~14k	18k	24k
	0.75	1.0	1.5	2.5
Unit(A)	Indoor	Indoor	Indoor	Indoor
Cable Type(B)	H05VV-F	H05VV-F	H05VV-F	H05VV-F

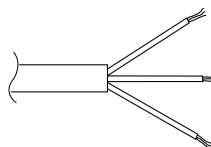

The power connecting cable connecting the indoor and outdoor unit should be selected according to the following specifications (Type "B" approved by HAR or SAA).

(mm²)

NORMAL CROSS SECTIONAL AREA	Grade			
	7k	9k~14k	18k	24k
	0.75	1.0	1.5	2.5
Cable Type(B)	H07RN-F	H07RN-F	H07RN-F	H07RN-F

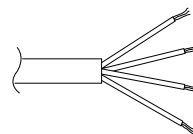

Connect the cable to the outdoor unit

Remove the control cover from the unit by loosening the screw.

Connect the wires to the terminals on the control board individually.

Secure the cable onto the control board with the cord clamp.

Refix the control cover to the original position with the screw.

Use a recognized circuit breaker "A" between the power source and the unit.
A disconnecting device to adequately disconnect all supply lines must be fitted.

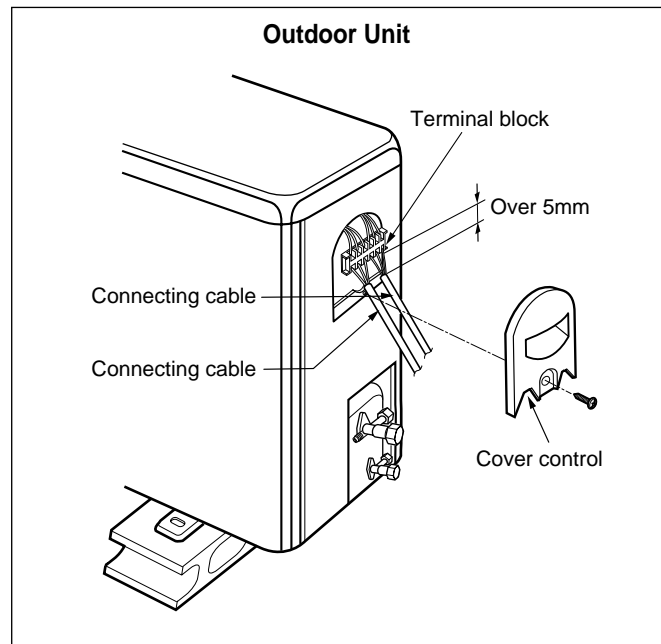

Circuit Breaker (A)	Grade				
	5k~14k	18k	24k~28k	30k, 32k	36k, 38k
	15	20	30	30	40

⚠ CAUTION

After the confirmation of the above conditions, prepare the wiring as follows:

- 1) Never fail to have an individual power circuit specifically for the air conditioner. As for the method of wiring, be guided by the circuit diagram posted on the inside of control cover.
- 2) The screw which fasten the wiring in the casing of electrical fittings are liable to come loose from vibrations to which the unit is subjected during the course of transportation. Check them and make sure that they are all tightly fastened. (If they are loose, it could cause burn-out of the wires.)
- 3) Specification of power source.
- 4) Confirm that electrical capacity is sufficient.
- 5) See to that the starting voltage is maintained at more than 90 percent of the rated voltage marked on the name plate.
- 6) Confirm that the cable thickness is as specified in the power source specification.
(Particularly note the relation between cable length and thickness. (Refer to page 21))
- 7) Always install an earth leakage circuit breaker in a wet or moist area.
- 8) The following would be caused by voltage drop.
 - Vibration of a magnetic switch, which will damage the contact point, fuse breaking, disturbance of the normal function of the overload.
- 9) The means for disconnection from a power supply shall be incorporated in the fixed wiring and have an air gap contact separation of at least 3mm in each active(phase) conductors.

Checking the drainage and forming the pipings

Checking the drainage

To remove the front panel from the indoor unit.

- Set the air direction louvers up-and-down to the position(horizontally) by hand.
- Remove the securing screws that retain the front panel. Pull the lower left and right sides of the grille toward you and lift it off.

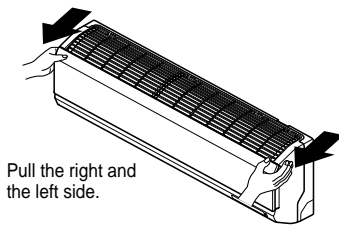

To check the drainage.

- Pour a glass of water on the evaporator.
- Ensure the water flows through the drain hose of the indoor unit without any leakage and goes out the drain exit.

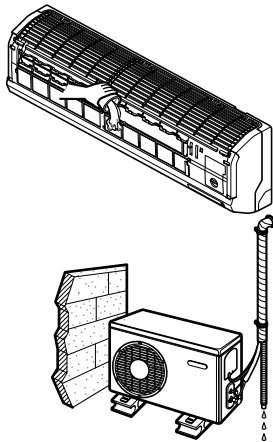

Drain piping

- The drain hose should point downward for easy drain flow.

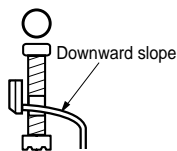

- Do not make drain piping.

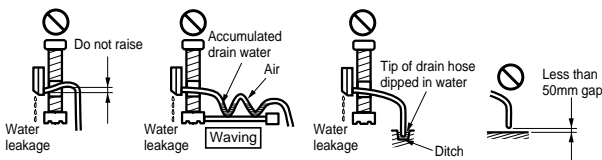

Form the piping

Form the piping by wrapping the connecting portion of the indoor unit with insulation material and secure it with two kinds of vinyl tapes.

- If you want to connect an additional drain hose, the end of the drain outlet should be routed above the ground. Secure the drain hose appropriately.

In cases where the outdoor unit is installed below the indoor unit perform the following.

- Tape the piping, drain hose and connecting cable from down to up.
- Secure the tapped piping along the exterior wall using saddle or equivalent.

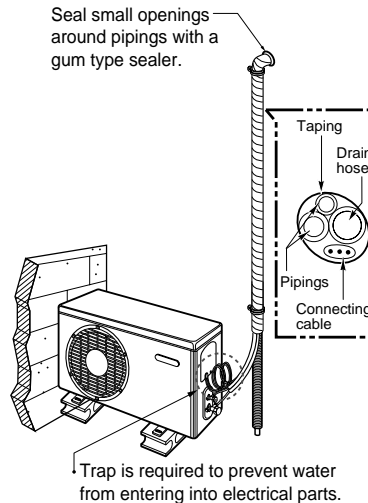

In cases where the Outdoor unit is installed above the Indoor unit perform the following.

- Tape the piping and connecting cable from down to up.
- Secure the taped piping along the exterior wall. Form a trap to prevent water entering the room.
- Fix the piping onto the wall by saddle or equivalent.

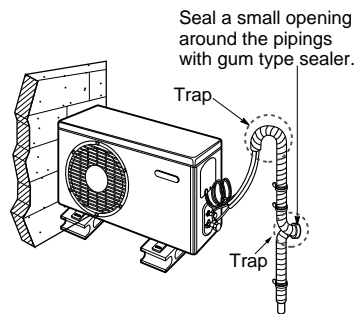

Air Purging

Air purging

Air and moisture remaining in the refrigerant system have undesirable effects as indicated below.

- Pressure in the system rises.
- Operating current rises.
- Cooling(or heating) efficiency drops.
- Moisture in the refrigerant circuit may freeze and block capillary tubing.
- Water may lead to corrosion of parts in the refrigeration system.

Therefore, the indoor unit and tubing between the indoor and outdoor unit must be leak tested and evacuated to remove any noncondensables and moisture from the system.

Air purging with vacuum pump

Preparation

- Check that each tube(both liquid and gas side tubes) between the indoor and outdoor units have been properly connected and all wiring for the test run has been completed. Remove the service valve caps from both the gas and the liquid side on the outdoor unit. Note that both the liquid and the gas side service valves on the outdoor unit are kept closed at this stage.

Leak test

- Connect the manifold valve(with pressure gauges) and dry nitrogen gas cylinder to this service port with charge hoses.

⚠ CAUTION

Be sure to use a manifold valve for air purging. If it is not available, use a stop valve for this purpose. The "Hi" knob of the manifold valve must always be kept close.

- Pressurize the system to no more than 150 P.S.I.G. with dry nitrogen gas and close the cylinder valve when the gauge reading reached 150 P.S.I.G. Next, test for leaks with liquid soap.

⚠ CAUTION

To avoid nitrogen entering the refrigerant system in a liquid state, the top of the cylinder must be higher than its bottom when you pressurize the system. Usually, the cylinder is used in a vertical standing position.

- Do a leak test of all joints of the tubing(both indoor and outdoor) and both gas and liquid side service valves. Bubbles indicate a leak. Be sure to wipe off the soap with a clean cloth.
- After the system is found to be free of leaks, relieve the nitrogen pressure by loosening the charge hose connector at the nitrogen cylinder. When the system pressure is reduced to normal, disconnect the hose from the cylinder.

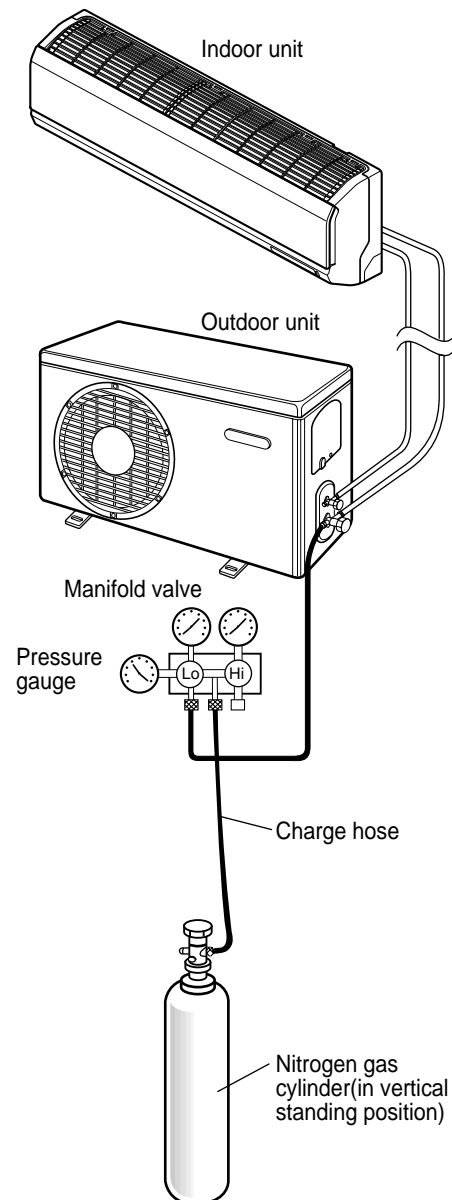

Soap water method

- (1) Remove the caps from the 2-way and 3-way valves.
- (2) Remove the service-port cap from the 3-way valve.
- (3) To open the 2-way valve turn the valve stem counter-clockwise approximately 90°, wait for about 2~3 sec, and close it.
- (4) Apply a soap water or a liquid neutral detergent on the indoor unit connection or outdoor unit connections by a soft brush to check for leakage of the connecting points of the piping.
- (5) If bubbles come out, the pipes have leakage.

Evacuation

- Connect the charge hose end described in the preceding steps to the vacuum pump to evacuate the tubing and indoor unit.
- Confirm the "Lo" knob of the manifold valve is open. Then, run the vacuum pump.
- The operation time for evacuation varies with tubing length and capacity of the pump. The following table shows the time required for evacuation.

Required time for evacuation when 30 gal/h vacuum pump is used	
If tubing length is less than 10m (33 ft)	if tubing length is longer than 10m (33 ft)
10 min. or more	15 min. or more

- When the desired vacuum is reached, close the "Lo" knob of the manifold valve and stop the vacuum pump.

Finishing the job

- With a service valve wrench, turn the valve stem of liquid side valve counter-clockwise to fully open the valve.
- Turn the valve stem of gas side valve counter-clockwise to fully open the valve.
- Loosen the charge hose connected to the gas side service port slightly to release the pressure, then remove the hose.
- Replace the flare nut and its bonnet on the gas side service port and fasten the flare nut securely with an adjustable wrench. This process is very important to prevent leakage from the system.
- Replace the valve caps at both gas and liquid side service valves and fasten them tight.

This completes air purging with a vacuum pump. The air conditioner is now ready to test run.

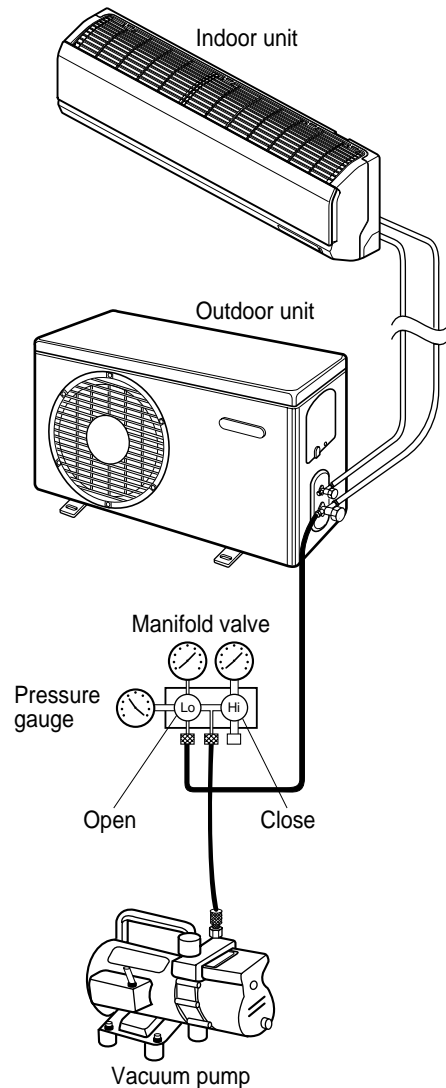
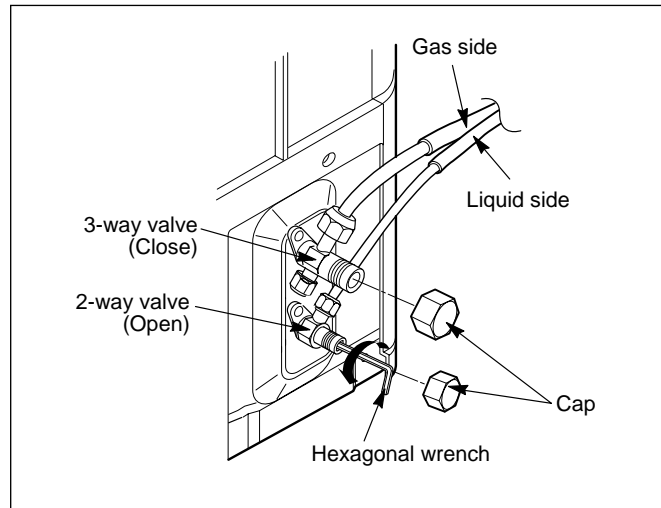

Test Running

1. Check that all tubing and wiring have been properly connected.
2. Check that the gas and liquid side service valves are fully open.

Settlement of outdoor unit

- Anchor the outdoor unit with a bolt and nut(ø10mm) tightly and horizontally on a concrete or rigid mount.
- When installing on the wall, roof or rooftop, anchor the mounting base securely with a nail or wire assuming the influence of wind and earthquake.
- In the case when the vibration of the unit is conveyed to the hose, secure the unit with an anti-vibration bushing.

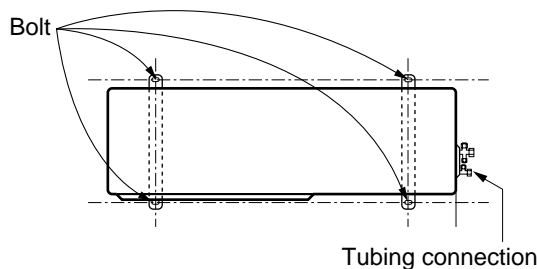

Evaluation of the performance

Operate unit for 15~20 minutes, then check the system refrigerant charge:

1. Measure the pressure of the gas side service valve.
2. Measure the temperature of the intake and discharge of air.
3. Ensure the difference between the intake temperature and the discharge is more than 8°C(46°F) (Cooling) or (Heating).

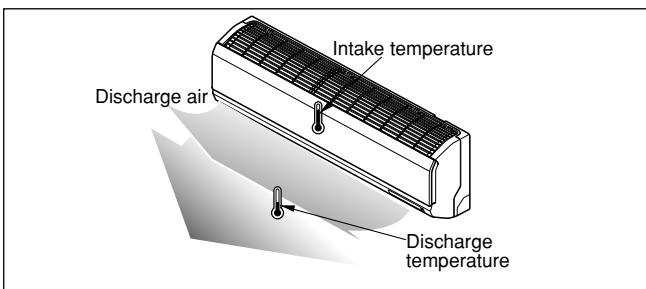

4. For reference; the gas side pressure of optimum condition is as below.(Cooling)

Refrigerant	Outside ambient TEMP.	The pressure of the gas side service valve.
R-22	35°C (95°F)	4~5kg/cm ² G(56.8~71.0 P.S.I.G.)
R-410A	35°C (95°F)	8.5~9.5kg/cm ² G(120~135 P.S.I.G.)

NOTE: If the actual pressure is higher than shown, the system is most likely over-charged, and charge should be removed. If the actual pressure are lower than shown, the system is most likely undercharged, and charge should be added.

The air conditioner is now ready for use.

PUMP DOWN

This is performed when the unit is to be relocated or the refrigerant circuit is serviced.

Pump Down means collecting all refrigerant in the outdoor unit without loss in refrigerant gas.

CAUTION:

Be sure to perform Pump Down procedure with the unit cooling mode.

Pump Down Procedure

1. Connect a low-pressure gauge manifold hose to the charge port on the gas side service valve.
2. Open the gas side service valve halfway and purge the air from the manifold hose using the refrigerant gas.
3. Close the liquid side service valve(all the way in).
4. Turn on the unit's operating switch and start the cooling operation.
5. When the low-pressure gauge reading becomes 1 to 0.5kg/cm² G(14.2 to 7.1 P.S.I.G.), fully close the gas side valve stem and then quickly turn off the unit. At that time, Pump Down has been completed and all refrigerant gas will have been collected in the outdoor unit.

Power-Failure Compensation Function User Selection ON/OFF

1) Operation Sequence

- ① Press the forced switch until BUZZER sounds 2 times (beep~beep~).
- ② Release the forced switch if BUZZER sounds.
- ③ Check the function selection ON/OFF with the operation LED.

2) Checking function-selection ON/OFF

- Function-Selection ON: One time blinking of operation LED would repeat 4 times.

- Function-Selection OFF: Two times blinking of operation LED would repeat 4 times.

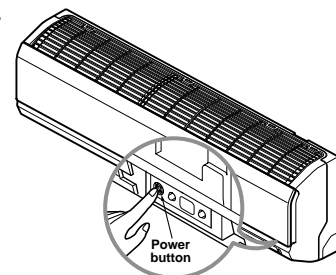

Functions

Indoor Unit

Cooling Mode Operation

Healthy dehumidification Mode Operation

Heating Mode Operation

Jet Cool Mode Operation

Jet Heat Mode Operation

Energy Saving Cooling Mode Operation

Operation ON/OFF by Remote controller

Sensing the Room Temperature

- Room temperature sensor. (Thermistor)
- Pipe temperature sensor. (Thermistor)

Room temperature control

- Maintain the room temperature in accordance with the Setting Temp.

Starting the Current Control

- Indoor fan is delayed for 5 sec at the starting.

Time Delay Safety Control

- Restarting is for approx. 2 minutes.

Indoor Fan Speed Control

- Super High, High, Med, Low

Operation indication Lamps (LED)

- ① --- Lights up in operation
- ☆ --- Lights up in Sleep Mode (Optional)
- ⌚ --- Lights up in Timer Mode
- ✱ --- Lights up in Preheat Mode (for Heating Model)
- 💧 --- Lights up in Plasma Air Clean Mode
- Ⓜ --- Lights up in during Energy-Saving Cooling Mode Operation (Optional)

Sleep Mode Auto Control

- The fan is switched to low(Cooling), low(Heating) speed.
- The unit will be stopped after 1, 2, 3, 4, 5, 6, 7 hours.

Natural Air Control by CHAOS Logic

- The fan is switched to intermittent or irregular operation
- The fan speed is automatically switched from high to low speed.

Airflow Direction Control

- The louver can be set at the desired position or swing up and down automatically.

Auto Changeover

Energy-Saving Control(Optional)

Horizontal airflow Direction Control(Optional)

Auto Clean(Optional)

Plasma

- The function will be operated while in any operation mode with selecting the function.
- The function is to be stopped while it isoperating with selecting the function.

Defrost(Deice) Control (Heating)

- Both the indoor and outdoor fan stops during defrosting.

Hot-start Control (Heating)

- The indoor fan stops until the evaporator pipe temperature will be reached at 34°C.

Heater (Optional)

Outdoor Unit

Power Relay Control

- If power is on, it will operate to charge capacitor on controller and power relay will operate after about 2~5sec.

Active Power Filter Control(PSC)

- The active power filter is designed to correct power factor($\cos \theta$) and to regulate DC link voltage.
- It will be operated PFC circuit when the compressor freq. is over 30Hz and wattage is over 450 watt.

Comp. Freq. Control

- The final operating freq. of comp. is set the lowest freq. that limited outdoor temp., discharge pipe temp., heat-sink temp., target freq., owing to CT.

Overheating. Protection(Power Module)

- When the temp. of power module increases to 85°C, controller decreases Freq. of Comp.

Freq. Speed Control(Up/Down Speed)

- It will be changed the drive freq. of comp. according to temp. of indoor and outdoor.

Total Current Control (Over Current Protection)

DC Peak Current Control

4 way Valve Control

- It is only operated in the heating operation mode except defrosting operation.

Outdoor Fan Motor Control

- High speed
 - Although fan motor speed is middle, it will change high speed in case of below AC193V, over 45°C of outdoor temp., and over fc, fh of comp. Freq.
- Middle speed
 - Nomal mode
- Low speed
 - Although fan motor speed is middle, it will change Low speed in case of over AC 270V, over 21°C (Heating Mode) of outdoor temp. below 24°C (Cooling Mode) of outdoor temp.

Discharge Pipe Temp. Control

Low Ambient

Comp. Torque Control

Over Heating Protection (Comp.)

Operation

Function of Controls

• DISPLAY

1) C/O Model

Operation Indicator

- ON while in appliance operation, OFF while in appliance pause.
- Flashing while in disconnection or short in Thermistor. (3 sec off / 0.5 sec on)

Timer Indicator

- ON while in timer mode (on/off), OFF when timer mode is completed or canceled.

Comp. Running Indicator

- While in appliance operation, ON while in outdoor unit compressor running, OFF while in compressor off.

2) H/P Model

Operation Indicator

- ON while in appliance operation, OFF while in appliance pause.
- Flashing while in disconnection or short in Thermistor. (3 sec off / 0.5 sec on)

Timer Indicator

- ON while in timer mode (on/off), OFF when timer mode is completed or canceled.

Defrost Indicator

- OFF except when hot start during heating mode operation or while in defrost control.

Protection of the evaporator pipe from frosting

- If the indoor pipe temperature is below 0°C in 7 min. after the compressor operates without pause while in cooling cycle operation mode,
 - compressor, outdoor fan are turned off.
- When indoor pipe temp. is 7°C or higher after 2 min pause of compressor
 - compressor, outdoor fan is turned on according to the condition of the room temperature.

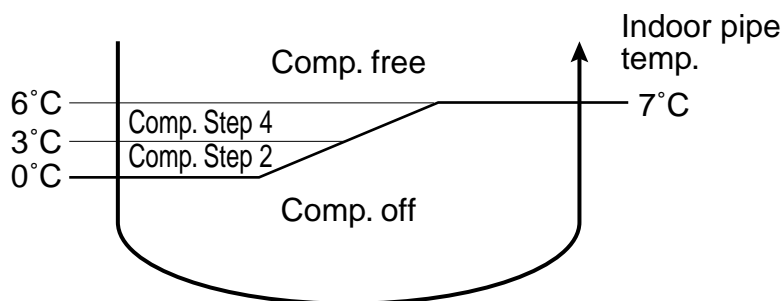

Cooling mode operation

- Operating frequency of compressor depend on the difference of the temperature.
(= intake air Temp.- Compressor off Temp.)
- Compressor off temp.= setting temp. -0.5°C
on temp. = setting temp. $+0.5^{\circ}\text{C}$
- If compressor operates at some operating frequency, the operating frequency of compressor cannot be changed within 30 seconds.
- Condition of compressor turned off
 - When intake air temperature stay at the temperature between setting temp. -0.5°C and setting temp. -1.0°C for 3 minutes continuously.
 - When intake air temperature reaches below the temperature of setting temp. -1.0°C .
- Compressor 2 minutes delay
 - The compressor can restart minimum 2 minutes later after compressor off.

[The operating freq. step of comp.]

Temp. differences	Comp. Operating frequency
over 2.5°C	Step 7
$2.0\sim 2.49^{\circ}\text{C}$	Step 6
$1.5\sim 1.99^{\circ}\text{C}$	Step 5
$1.0\sim 1.49^{\circ}\text{C}$	Step 4
$0.5\sim 0.99^{\circ}\text{C}$	Step 3
$0.0\sim 0.49^{\circ}\text{C}$	Step 2
$0.5\sim 0^{\circ}\text{C}$	Step 1

[The targeting operating freq. of comp. each model]

Model	Comp. Operating frequency						
	Step 1	Step 2	Step 3	Step 4	Step 5(Fc)	Step 6	Step 7
AS-W0964DH0/GH0	35	39	43	47	52	57	62
AS-W1264DH0/GH0	20	35	47	56	63	70	78
AS-W1865DH0/GH0	16	32	58	64	70	75	85
AS-W1224DH0	20	35	47	54	65	70	74
AS-W1424DH0	20	35	47	54	72	74	78
AS-W1825DH0	16	32	53	62	72	75	85

Healthy Dehumidification mode operation

- When the dehumidification operation is set by the remote controller the intake air temperature is detected and the setting temp. is automatically set according to the intake air temperature.

Intake air Temp.	Setting Temp.
$26^{\circ}\text{C} \leq$ intake air temp.	25°C
$24^{\circ}\text{C} \leq$ intake air temp. $< 26^{\circ}\text{C}$	intake air temp. -1°C
$18^{\circ}\text{C} <$ intake air temp. $< 24^{\circ}\text{C}$	intake air temp. -0.5°C
intake air temp. $\leq 18^{\circ}\text{C}$	18°C

- When intake air temp reaches above the temp of setting $+1.0^{\circ}\text{C}$, condition of compressor same as cooling mode operation.
- When intake air temperature reaches below the temp of setting -1.0°C , compressor operate step1~step3 and indoor fan speed repeatedly operate low or stop.

Heating mode operation

- Operating frequency of compressor depend on the difference of the temperature
(= compressor off temp. - intake air temp.)
- Compressor off temp. = setting temp.+3.0°C
on temp. = setting temp.
- If compressor operates at some operation frequency, the operating frequency of compressor cannot be changed within 30 seconds.
- Condition of compressor turned off
 - When intake air temperature reaches +3°C above the setting temperature.
- Condition of indoor fan turned off
 - While in compressor on:indoor pipe temp. < 30°C
- While in defrost control, between the indoor and outdoor fans are turned off.
- Compressor 2minutes delay
 - After compressor off, the compressor can restart minimum 2 minutes later.

[The operating freq. step of comp]

Temp. differences	Comp. Operating frequency
2.5~3.0°C	Step 1
2.0~2.49°C	Step 2
1.5~1.99°C	Step 3
1.0~1.49°C	Step 4
0.5~0.99°C	Step 5
0.0~0.49°C	Step 6
~-0.0°C	Step 7

[The targeting operating freq. of comp. each model]

Model	Comp. Operating frequency						
	Step 1	Step 2	Step 3	Step 4	Step 5	Step 6	Step 7
AS-W0964DH0/GH0	35	44	53	62	69	74	80
AS-W1264DH0/GH0	20	38	53	63	72	79	86
AS-W1865DH0/GH0	16	38	47	65	79	87	96
AS-W1224DH0	20	35	53	63	70	79	86
AS-W1424DH0	20	35	53	63	77	79	86
AS-W1825DH0	16	38	47	62	79	87	90

Jet cool mode operation

- While in heating mode or Fuzzy operation, the Jet Cool key cannot be input. When it is input while in the other mode operation(cooling, dehumidification, ventilation), the Jet Cool mode is operated.
- In the Jet Cool mode, the indoor fan is operated super-high speed for 30 min. at cooling mode operation.
- In the Jet Cool mode, the room temperature is controlled to the setting temperature, 18°C.
- When the sleep timer mode input while the Jet Cool mode operation, the Jet Cool mode has the priority.
- When the Jet Cool key is input, the upper/lower vane is reset to those of the initial cooling mode and then operated in order that the air outflow could reach further.

Jet heat mode operation

- While in cooling mode or Fuzzy operation, the Jet Heat key cannot be input. When it is input while in the Heating mode operation (dehumidification), the Jet Heat mode is operated.
- In the Jet Heat mode, the indoor fan is operated super-high speed for 60 min. at Heating mode operation.
- In the Jet Heat mode, the room temperature is controlled to the setting temperature, 30°C.
- When the sleep timer mode input while the Jet Heat mode operation, the Jet Heat mode has the priority.
- When the Jet Heat key is input, the upper/lower vane is reset to those of the initial Jet heating mode and then operated in order that the air outflow could reach under flow.

Swing mode

1. New Chaos swing mode

- By the Chaos swing key input, the upper/lower vane automatically operates with the Chaos swing or it is fixed to the desired direction.

(S4) 7, 9, 12, 14k Model

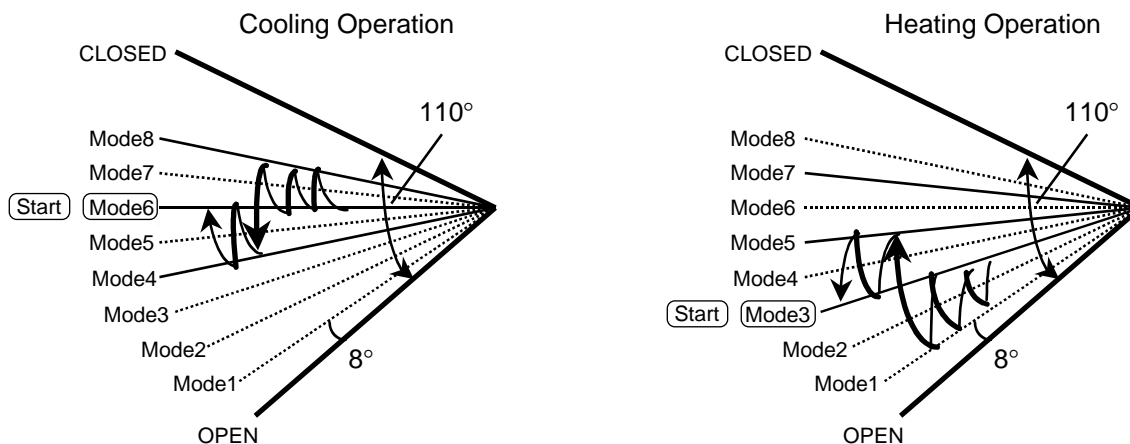

S5) 18, 24k Model

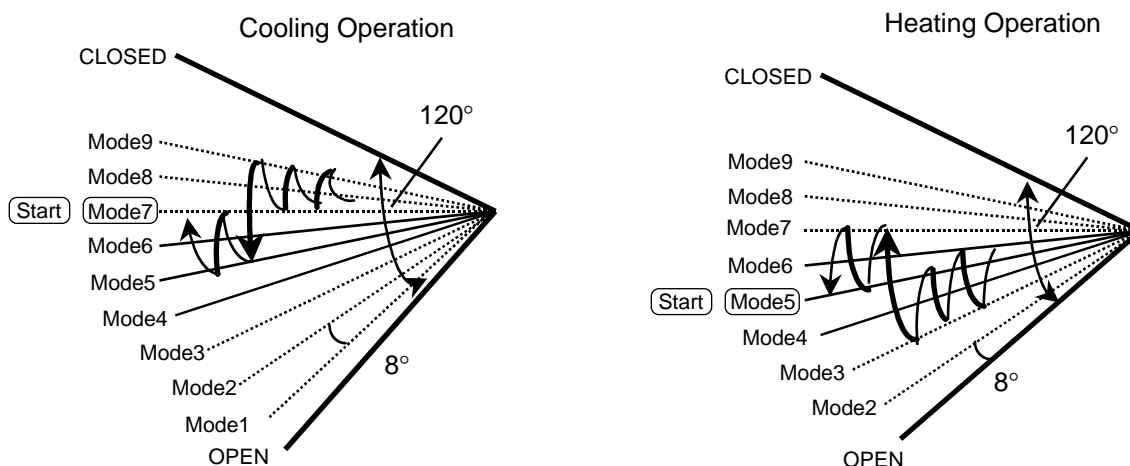

Sleep timer operation

- When the sleep time is reached after [1,2,3,4,5,6,7hr] is input by the remote control during the operation, the operation of the appliance stops.
- When the appliance is on pause, the sleep timer mode cannot be input.

1. Sleep timer operation for cooling cycle

- While in cooling mode operation, 30 min. later since the start of the sleep timer, the setting temperature increase by 1°C. After another 30min. elapse, it increases by 1°C again.

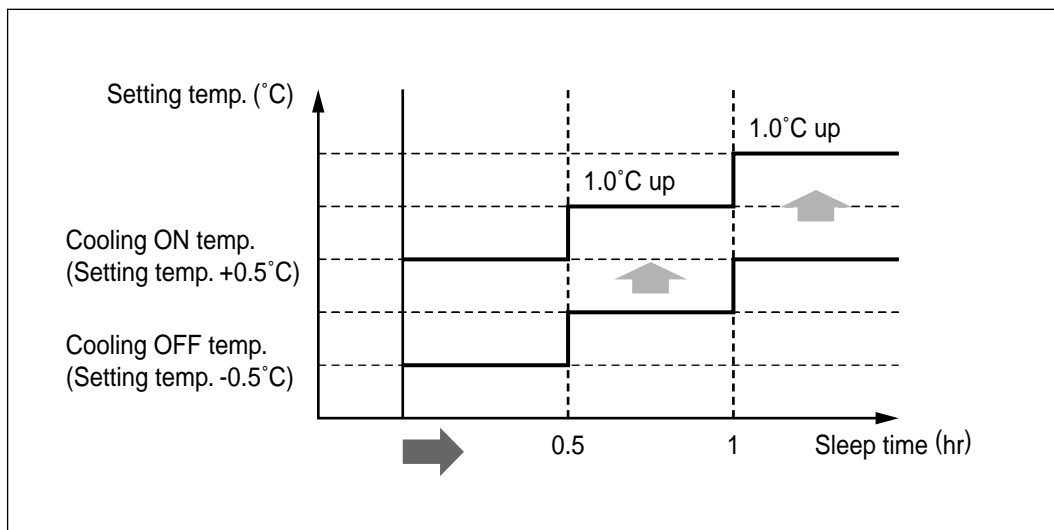

2. Sleep timer operation for heating cycle

- While in heating mode operation, 60 min. later since the start of the sleep timer, the setting temperature decrease by 1°C. After another 60min. elapse, it decreases by 1°C again.

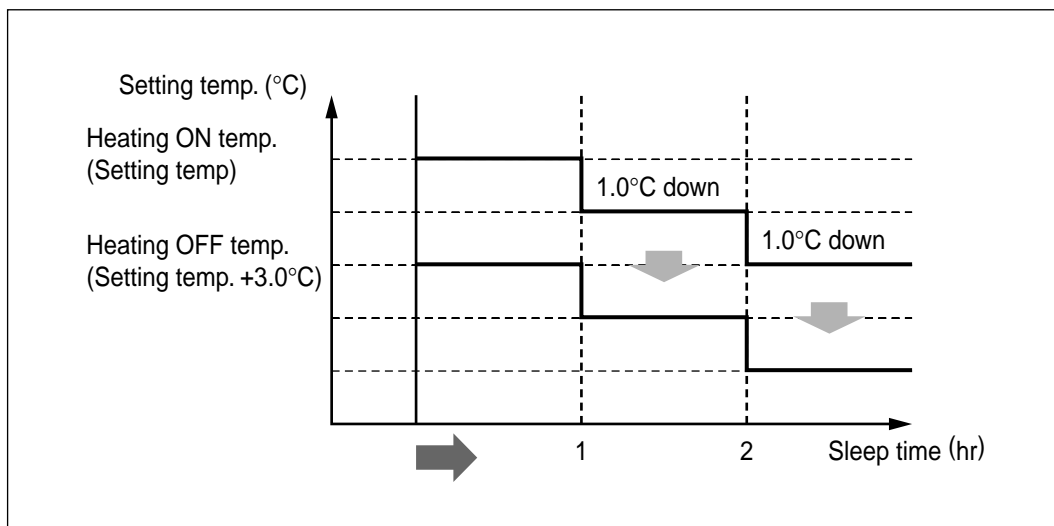

Auto restarting operation

- When the power is restarted after a sudden power failure while in appliance operation, the mode before the power failure is kept on the memory and the appliance automatically operates in the mode on the memory.
- Operation mode that is kept on the memory
 - State of operation ON/OFF
 - Operation mode/setting temp./selected airflow speed
 - Sleep timer mode/remaining time of sleep timer
 - Chaos Swing

Forced operation

- To operate the appliance by force in case that the remote control is lost, the forced operation selection switch is on the main unit of the appliance to operate the appliance in the standard conditions.
- The operation condition is set according to the outdoor temp. and intake air temperature as follows.

Indoor temp.	Operating Mode	Setting temp.	Setting speed of indoor fan
over 24°C	Cooling	22°C	High speed
21~24°C	Healthy Dehumidification	23°C	
below 21°C	Heating	24°C	

- ✱ The unit select before operating mode in 3 hours.

Test Operation

- Press the Tact Switch for compulsory operation of the main body for 3 seconds in order to operate in the trial operation mode.
 - Operation mode: Cold
 - Indoor fan: Strong wind
 - COMP frequency: Step 5
 - COMP compulsorily operates for about 18 minutes irrespective of indoor temperature.

Power relay control

- Power relay turns on 1 second later after the power is input to the outdoor unit.
- Control sequence : power on → PTC operating → power relay on

Protection from total current control

■ CT1 control

- If the operating current reaches I1, the operating frequency of the compressor decrease.
- After decreasing the operating frequency by 1step, if operating current is below I1 for 60 seconds continuously, the operating frequency of compressor increase by 1step.

■ CT2 control

- If the operating current of the appliance reaches I2, the compressor stop instantly and 2 minutes later the compressor restart again.
- If CT2 occurs 5 times within 1hour, the appliance turn off and display ERROR CODE 7.

Control table		* I1: Current of operating frequency down I2: Current of compressor cut off				
		I1				I2
		Outdoor temp ≥ 38°C		Outdoor temp < 38°C		
Cooling	Heating	Cooling	Heating			
1	AS-0964DH0	5.5	6.5	6	7	9
2	AS-1264DH0	6.5	7.5	7	8	10
3	AS-1865DH0	9.0	10.5	9.5	11.0	13

cf. I1 is set the lowest level between initial value and in case detection of dc paeak current.

Protection from DC Peak Current

■ DC Peak Current Error by a fault signal of IPM

- If the operating current of IPM reaches 35A ±3A, the compressor stop instantly.
- If DC PEAK occurs 5 times within 1 hour, the appliance turns off and display ERROR CODE 6.

■ DC Peak Current Error by the compressor lock

- If the DC LINK voltage below DC 140V occurs 5 times within 1 hour while the compressor is operating, the appliance turns off and display ERROR CODE 6.

■ DC Peak Current Error by the Outdoor Fan Lock

- If it's 5 times within 1 hour in case of the temperature of outdoor pipe TH is over 65°C while the compressor is operating, the appliance turns off and display ERROR CODE 6.

Portection from overheating of power module

- If the temperature of the heat sink TH. reaches over Toff, the Compressor stop instantly.
- It will be limited the compressor operating frequency according to the heat sink TH.(refer to below FIG.)
- It will be blink 4 times, when the thermistor is open or short, also the temperature is over Toff.

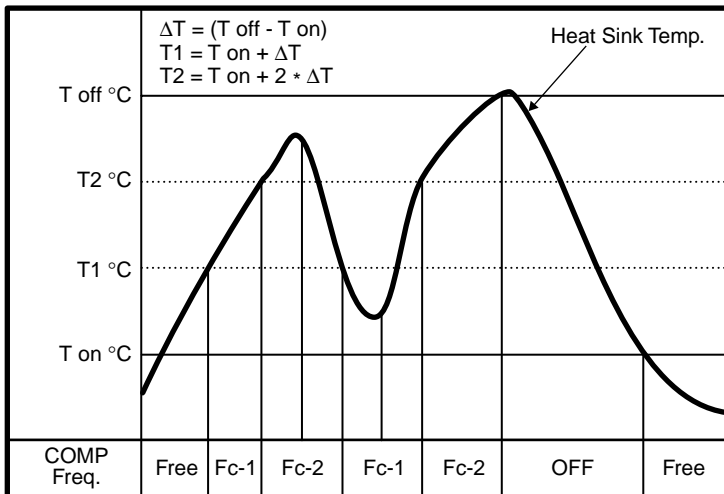

No.	MODEL	T on	T off
1	AS-W0964DH0	95	105
2	AS-W1264DH0	95	105
3	AS-W1865DH0	85	95

Portection from overheating of compressor

- If the temperature of the discharge pipe of compressor reaches over 130°C or below -30°C the compressor stop instantly.
- It will be limited the compressor operating frequency according to the compressor dome TH.(Refer to below Fig.)
- Temperature range by COMP SPEC varies by 10°C.

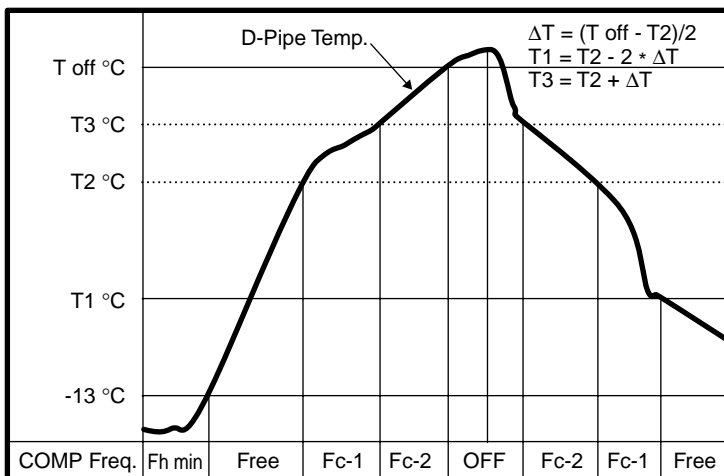

No.	MODEL	T on	T off
1	AS-W0964DH0	95	105
2	AS-W1264DH0	95	105
3	AS-W1865DH0	98	108

Defrosting control

- While in heating mode operation in order to protect the evaporator pipe of the outdoor unit from freezing, reversed to cooling cycle to defrost the evaporator pipe of the outdoor unit.
- Defrosting control is available 50 minutes later since heating cycle started and the pipe temperature of outdoor unit reaches below -6°C.

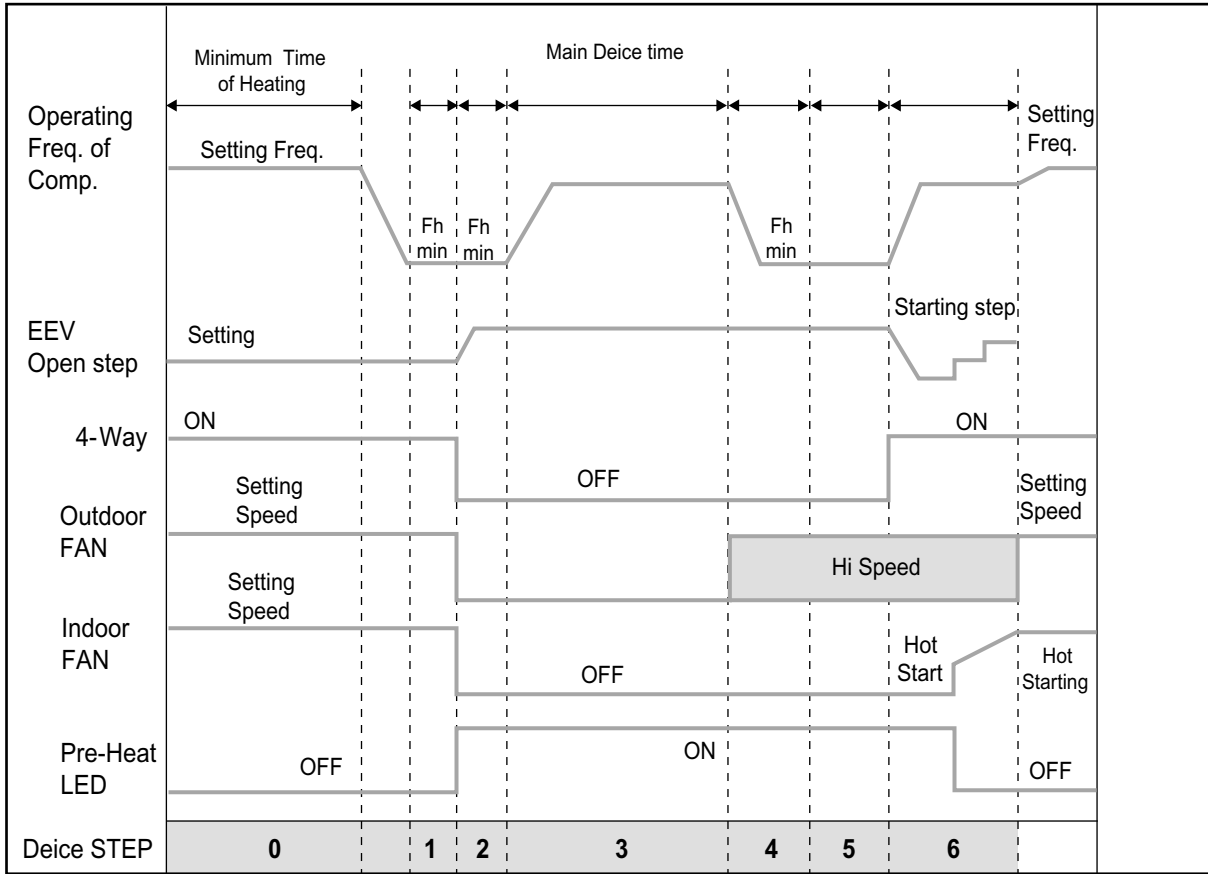

Auto Cleaning

- Function used to perform the Self Cleaning to prevent the Unit from Fungus and Bad Odors.
- Used after the Shut Down of Cooling Operation to Clean the Evaporator and keep it as fresh for the Next operation.
- During Self Cleaning the Outdoor Unit is Switched off.
- The function is easy to be operated as It is accessed through the Remote Controller.

1) Heat/pump Model

	ON	OFF			
	Cooling CYCLE		Fan	Heating	Fan
Comp.	ON		13 Min OFF	60 Sec ON	120 Sec OFF
Indoor Fan	Setting Step		Low	Low	Low

2) Cooling/only Model

	ON	OFF	
	Cooling CYCLE		Fan
Comp.	ON		30 Min OFF
Indoor Fan	Setting Step		Low

Auto Changeover

- The air conditioner changes the operation mode automatically to keep indoor temperature.
- When room temperature vary over $\pm 2^{\circ}\text{C}$ with respect to setting temperature, air conditioner keeps the room temperature in $\pm 2^{\circ}\text{C}$ with respect to setting temperature by auto change mode.

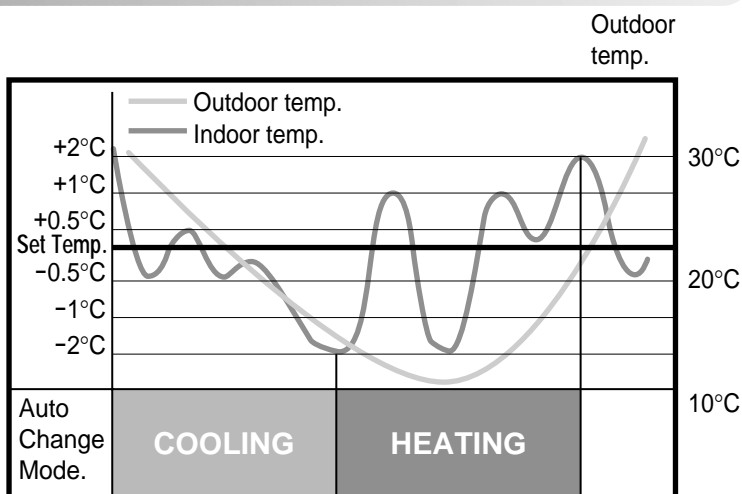

Low Ambient

- If outdoor temperature drops below certain temperature, liquid back is prevented by reducing fan speed. It can prevent frosting of evaporator and keep cooling operation
- No matter even if the outdoor temperature reaches -10°C .
- You can Cool your room at your desired temperature all your around.

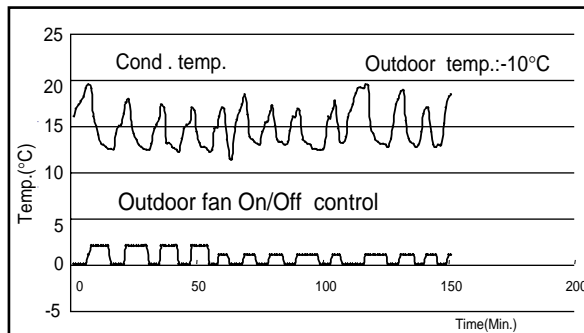
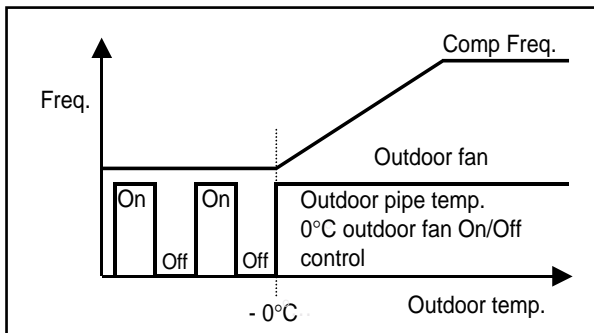

Remote Control Operations

The controls will look like the following.

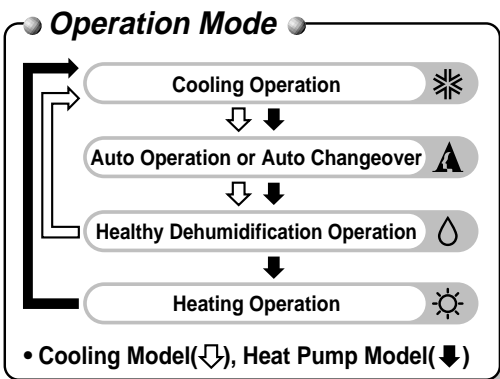
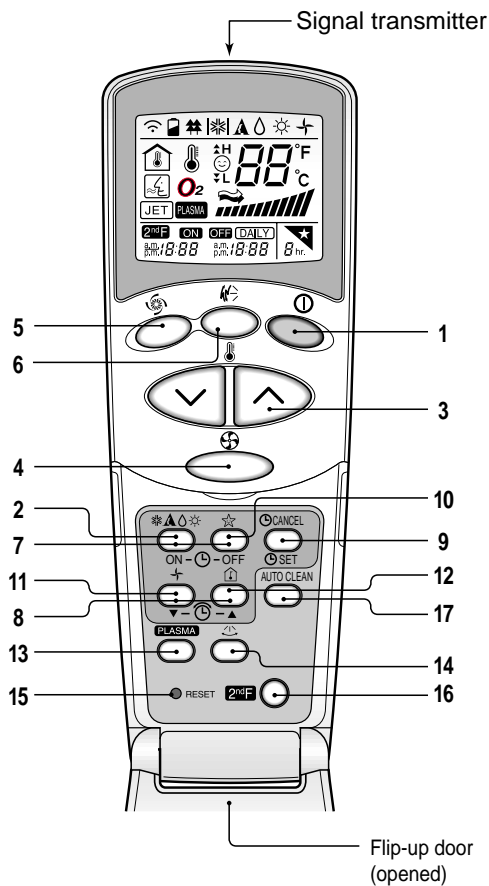

1. START/STOP BUTTON

Operation starts when this button is pressed and stops when the button is pressed again.



2. OPERATION MODE SELECTION BUTTON

Used to select the operation mode.



3. ROOM TEMPERATURE SETTING BUTTONS

Used to select the room temperature.



4. INDOOR FAN SPEED SELECTOR

Used to select fan speed in four steps: low, medium, high and CHAOS.



5. JET COOL/JET HEAT

Used to start or stop the speed cooling/heating. (speed cooling/heating operates super high fan speed in cooling/heating mode.)



6. CHAOS SWING BUTTON

Used to stop or start louver movement and set the desired up/down airflow direction.



7. ON/OFF TIMER BUTTONS

Used to set the time of starting and stopping operation.

8. TIME SETTING BUTTONS

Used to adjust the time.

9. TIMER SET/CANCEL BUTTON

Used to set the timer when the desired time is obtained and to cancel the Timer operation.

10. SLEEP MODE AUTO BUTTON

Used to set Sleep Mode Auto operation.

11. AIR CIRCULATION BUTTON

Used to circulate the room air without cooling or heating.

12. ROOM TEMPERATURE CHECKING BUTTON

Used to check the room temperature.

13. PLASMA(OPTIONAL)

Used to start or stop the plasma function.

14. HORIZONTAL AIRFLOW DIRECTION CONTROL BUTTON (OPTIONAL)

Used to set the desired horizontal airflow direction.

15. RESET BUTTON

Used prior to resetting time.

16. 2ND F BUTTON

Used prior to using modes printed in blue at the bottom of buttons.

17. AUTO CLEAN (OPTIONAL)

Used to set Auto Clean mode.

Disassembly

Indoor Unit

▲ WARNING

Disconnect the unit from power supply before making any checks.
Be sure the power switch is set to "OFF".

To remove the Grille from the Chassis.

- Set the up-and-down air discharge louver to open position (horizontally) by finger pressure.
- Remove the securing screws.
- To remove the Grille, pull the lower left and right side of the grille toward you (slightly tilted) and lift it straight upward.

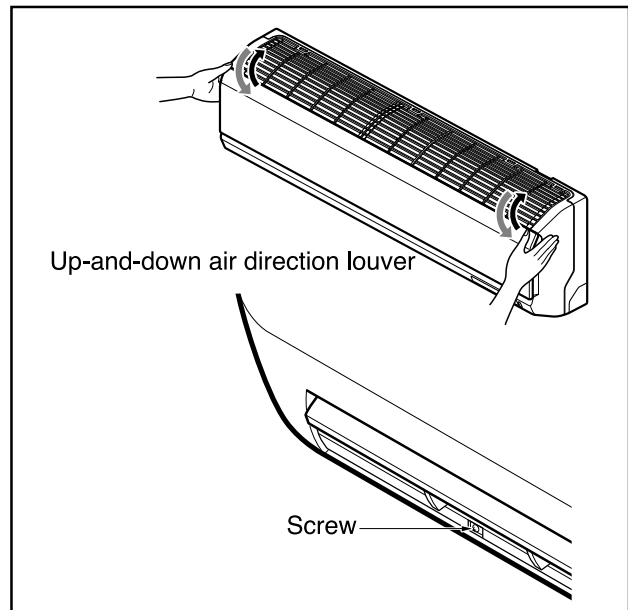

1. Before removing the control box, be sure to take out the wire screwed at the other end.

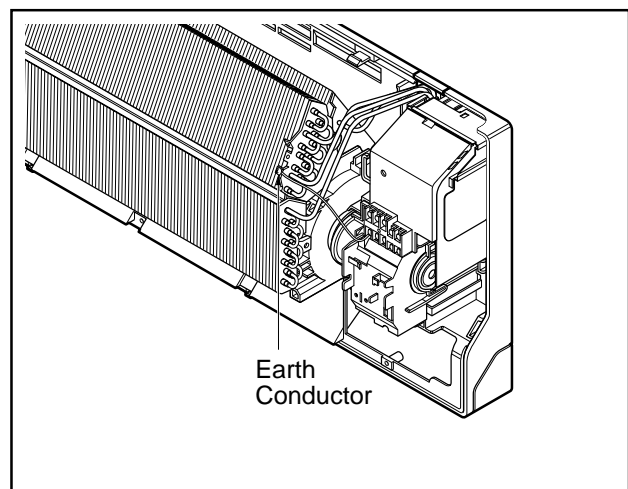

2. To remove the Control Box.

- Remove securing screws.
- Pull the control box out from the chassis carefully.

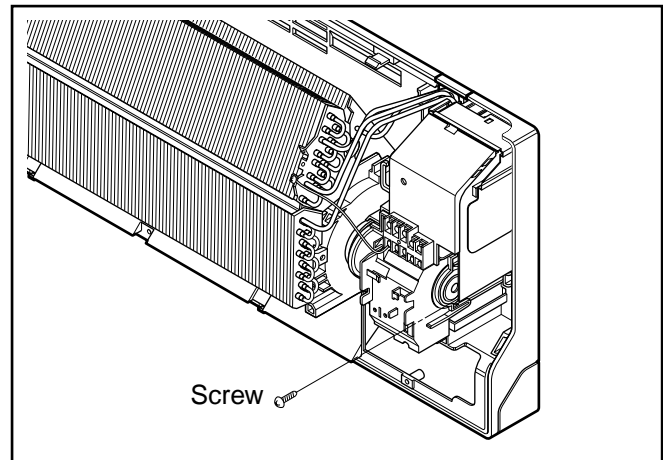

3. To remove the Discharge Grille.

- Unhook the discharge grille and pull the discharge grille out from the chassis carefully.

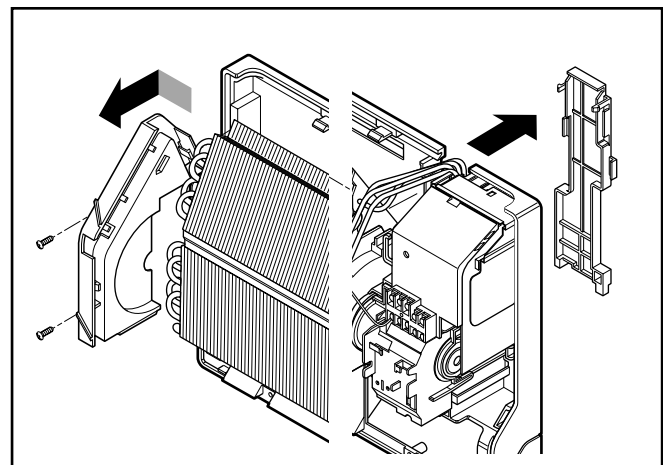

4. To remove the Evaporator.

- Remove 3 screws securing the evaporator(at the left 2EA in the Eva Holder, at the right 1EA).

▲ CAUTION

- When repair, do not damage the Caution label.

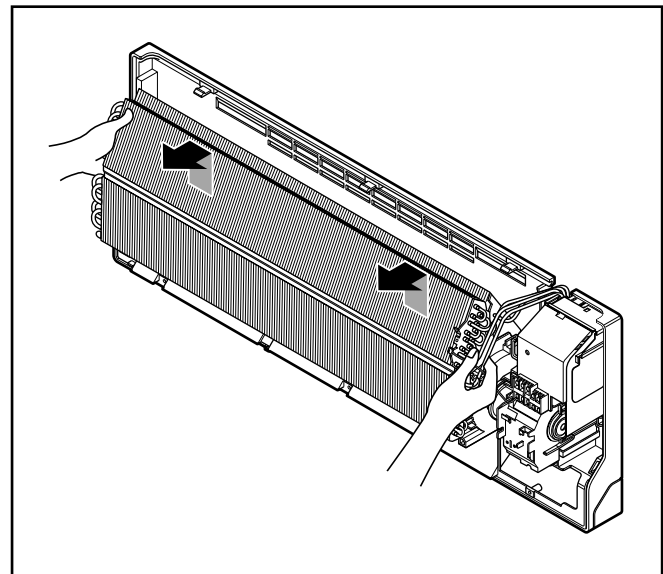

- Unhook the tab on the right inside of the chassis at the same time, slightly pull the evaporator toward you until the tab is clear of the slot.

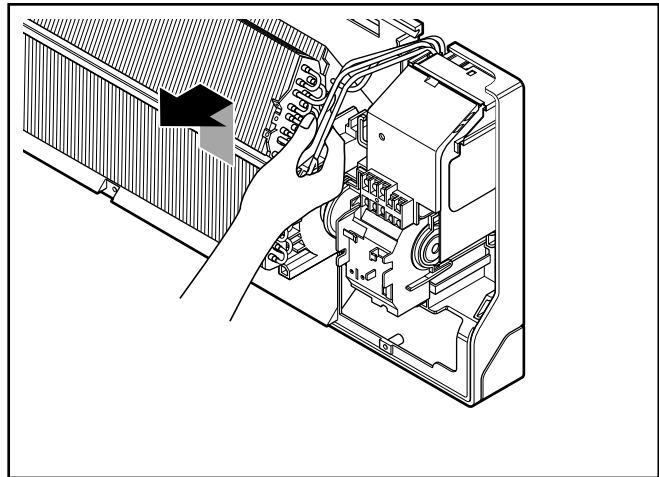

5. To remove the Motor Cover

- Remove 2 securing screw.
- Pull the motor cover out from the chassis carefully.

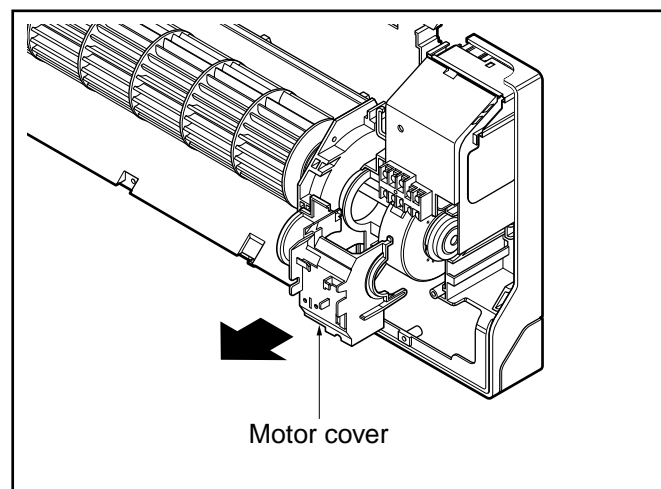

6. To remove the Cross-Flow Fan

- Loosen the screw securing the cross-flow fan to the fan motor (do not remove).
- Lift up the right side of the cross-flow fan and the fan motor, separate the fan motor from the cross-flow fan.

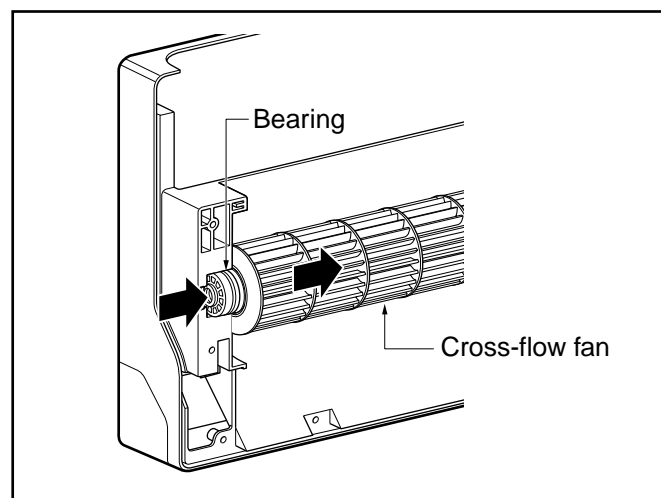

- Remove the left end of the cross-flow fan from the self-aligning bearing.

Troubleshooting Guide

Refrigeration Cycle Diagram

(1) Cooling Only Models

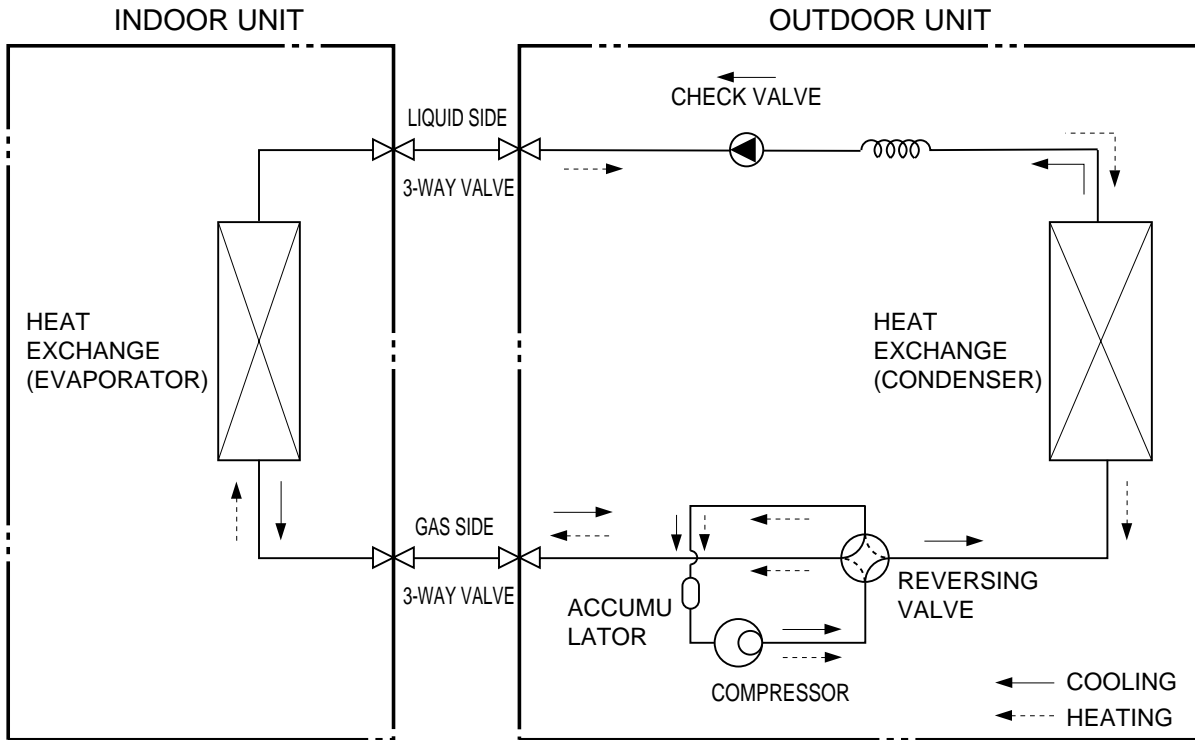

(2) Cooling & Heating Models

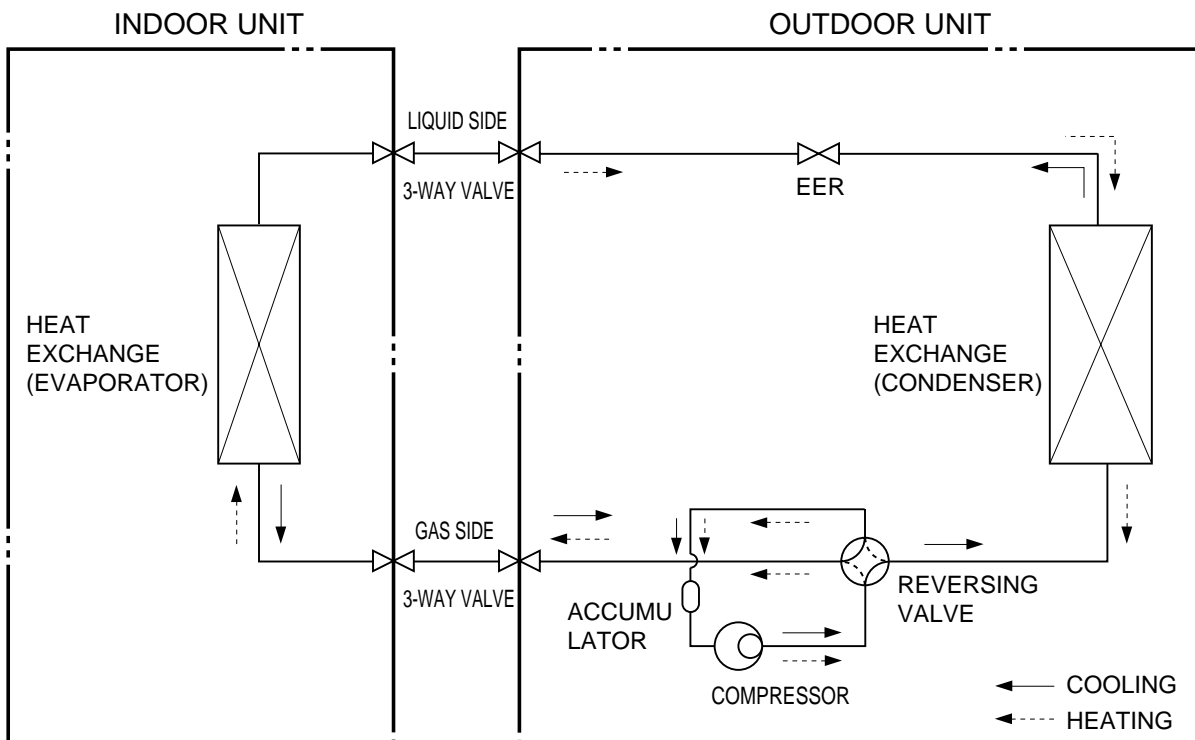

Pipe Length and the Elevation

Capacity (Btu/h)	Pipe Size		Standard Length (m)	Max. Elevation (B) (m)	Max. Length (A) (m)	Additional Refrigerant (g/m)
	GAS	LIQUID				
7k~14k	3/8" (Ø9.52)	1/4" (Ø6.35)	4 or 7.5	7	15	20
	1/2" (Ø12.7)	1/4" (Ø6.35)	4 or 7.5	7	15	20
18k~28k	1/2" (Ø12.7)	1/4" (Ø6.35)	4 or 7.5	15	30	20
	5/8" (Ø15.88)	1/4" (Ø6.35)	4 or 7.5	15	30	20
	5/8" (Ø15.88)	3/8" (Ø9.52)	4 or 7.5	15	30	30
30k~38k	5/8" (Ø15.88)	3/8" (Ø9.52)	7.5	15	30	30
	3/4" (Ø19.05)	3/8" (Ø9.52)	7.5	15	30	50

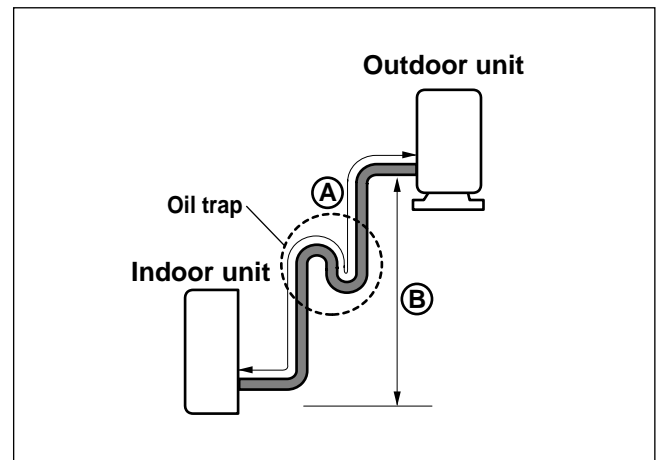
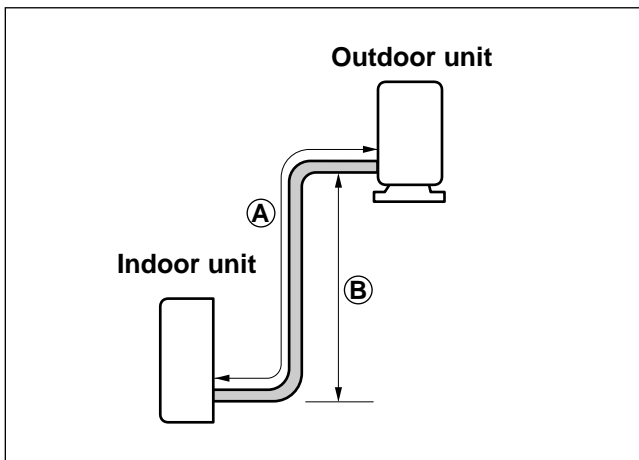

In case more than 5m



CAUTION:* Capacity is based on standard length and maximum allowance length is the basis of reliability.

* Oil trap should be installed per 5~7 meters.

2-way, 3-way Valve

		2-way Valve (Liquid Side)	3-way Valve (Gas Side)	
Works		Shaft position	Shaft position	Service port
Shipping		Closed (with valve cap)	Closed (with valve cap)	Closed (with cap)
1.	Air purging (Installation)	Open (counter-clockwise)	Closed (clockwise)	Open (push-pin or with vacuum pump)
Operation		Open (with valve cap)	Open (with valve cap)	Closed (with cap)
2.	Pumping down (Transferring)	Closed (clockwise)	Open (counter-clockwise)	Open (connected manifold gauge)
3.	Evacuation (Servicing)	Open	Open	Open (with charging cylinder)
4.	Gas charging (Servicing)	Open	Open	Open (with charging cylinder)
5.	Pressure check (Servicing)	Open	Open	Open (with charging cylinder)
6.	Gas releasing (Servicing)	Open	Open	Open (with charging cylinder)

Air purging

Required tools : hexagonal wrench, adjustable wrench, torque wrenches, wrench to hold the joints, and gas leak detector.

The additional gas for air purging has been charged in the outdoor unit.

However, if the flare connections have not be done correctly and there gas leaks, a gas cylinder and the charge set will be needed.

The air in the indoor unit and in the piping must be purged. If air remains in the refrigeration pipes, it will affect the compressor, reduce to cooling capacity, and could lead to a malfunction.

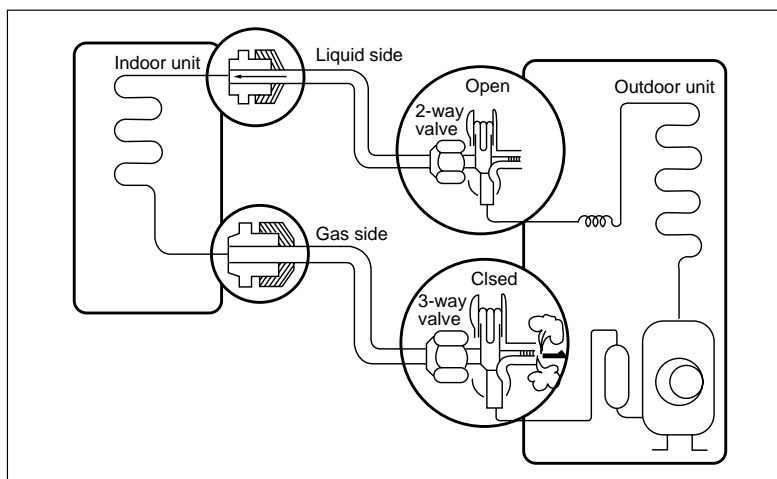

Service port nut:

Be sure, using a torque wrench to tighten the service port nut (after using the service port), so that it prevents the gas leakage from the refrigeration cycle.



CAUTION: Do not leak the gas in the air during Air purging.

• Procedure

- (1) Recheck the piping connections.
- (2) Open the valve stem of the 2-way valve counterclockwise approximately 90°, wait 10 seconds, and then set it to closed position.
 - Be sure to use a hexagonal wrench to operate the valve stem.
- (3) Check for gas leakage.
 - Check the flare connections for gas leakage.
- (4) Purge the air from the system.
 - Set the 2-way valve to the open position and remove the cap from the 3-way valve's service port.
 - Using the hexagonal wrench to press the valve core pin, discharge for three seconds and then wait for one minute. Repeat this three times.
- (5) Use torque wrench to tighten the service port nut to a torque of 1.8kg.cm.

- (6) Set the 3-way valve to the back seat.
- (7) Mount the valve stem nuts to the 2-way and 3-way valves.
- (8) Check for gas leakage.
 - At this time, especially check for gas leakage from the 2-way and 3-way valve's stem nuts, and from the service port nut.



CAUTION: If gas leakage are discovered in step (3) above, take the following mesures :

If the gas leaks stop when the piping connections are tightened further, continue working from step (4). If the gas leaks do not stop when the connections are retightened, repair the location of the leak, discharge all of the gas through the service port, and then recharge with the specified amount of gas from a gas cylinder.

Pumping Down

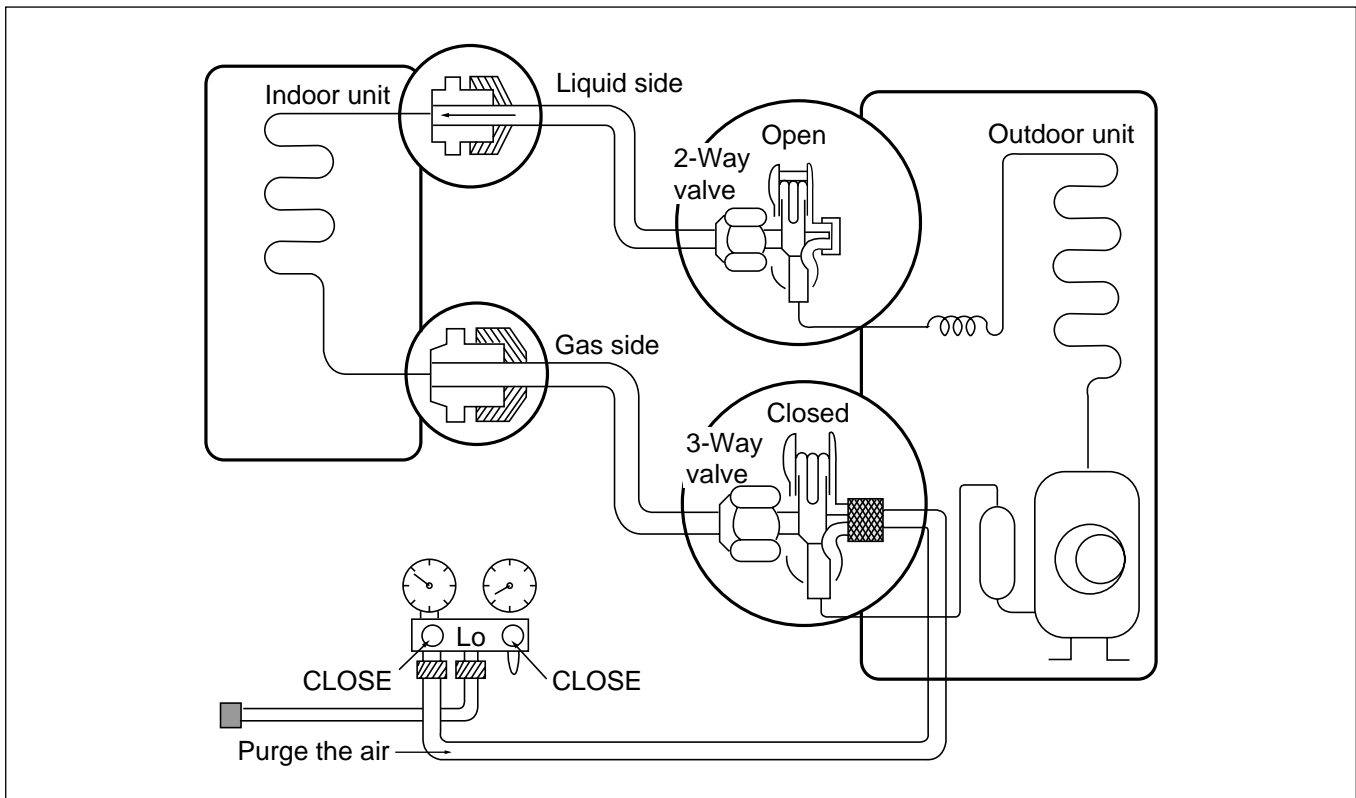

• Procedure

(1) Confirm that both the 2-way and 3-way valves are set to the open position.

- Remove the valve stem caps and confirm that the valve stems are in the raised position.
- Be sure to use a hexagonal wrench to operate the valve stems.

(2) Operate the unit for 10 to 15 minutes.

(3) Stop operation and wait for 3 minutes, then connect the charge set to the service port of the 3-way valve.

- Connect the charge hose with the push pin to the service port.

(4) Air purging of the charge hose.

- Open the low-pressure valve on the charge set slightly to air purge from the charge hose.

(5) Set the 2-way valve to the closed position.

(6) Operate the air conditioner at the cooling cycle and stop it when the gauge indicates $1\text{kg/cm}^2\text{g}$.

(7) Immediately set the 3-way valve to the closed position.

- Do this quickly so that the gauge ends up indicating $3\text{ to }5\text{kg/cm}^2\text{g}$.

(8) Disconnect the charge set, and mount the 2-way and 3-way valve's stem nuts and the service port nut.

- Use torque wrench to tighten the service port nut to a torque of 1.8 kg.m .
- Be sure to check for gas leakage.

Re-air Purging

(Re-installation)

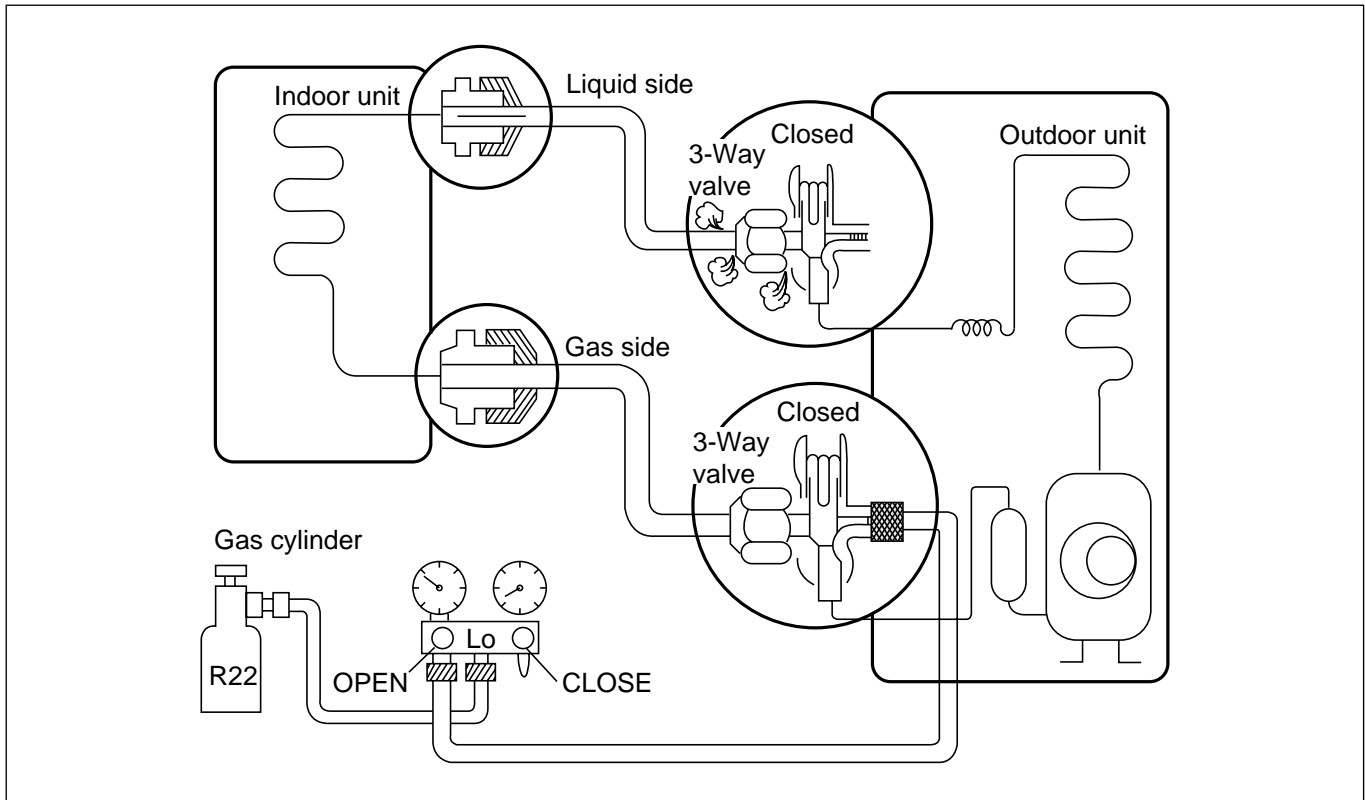

• Procedure

(1) Confirm that both the liquid side valve and the gas side valve are set to the closed position.

(2) Connect the charge set and a gas cylinder to the service port of the Gas side valve.

- Leave the valve on the gas cylinder closed.

(3) Air purging.

- Open the valves on the gas cylinder and the charge set. Purge the air by loosening the flare nut on the liquid side valve approximately 45° for 3 seconds then closing it for 1 minute; repeat 3 times.
- After purging the air, use a torque wrench to tighten the flare nut on liquid side valve.

(4) Check for gas leakage.

- Check the flare connections for gas leakage.

(5) Discharge the refrigerant.

- Close the valve on the gas cylinder and discharge the refrigerant until the gauge indicates 3 to 5 kg/cm²g.

(6) Disconnect the charge set and the gas cylinder, and set the Liquid side and Gas side valves to the open position.

- Be sure to use a hexagonal wrench to operate the valve stems.

(7) Mount the valve stem nuts and the service port nut.

- Use torque wrench to tighten the service port nut to a torque of 1.8 kg.m.
- Be sure to check for gas leakage.



CAUTION: Do not leak the gas in the air during Air Purging.

Balance Refrigerant of the 3-way Valve

(Gas leakage)

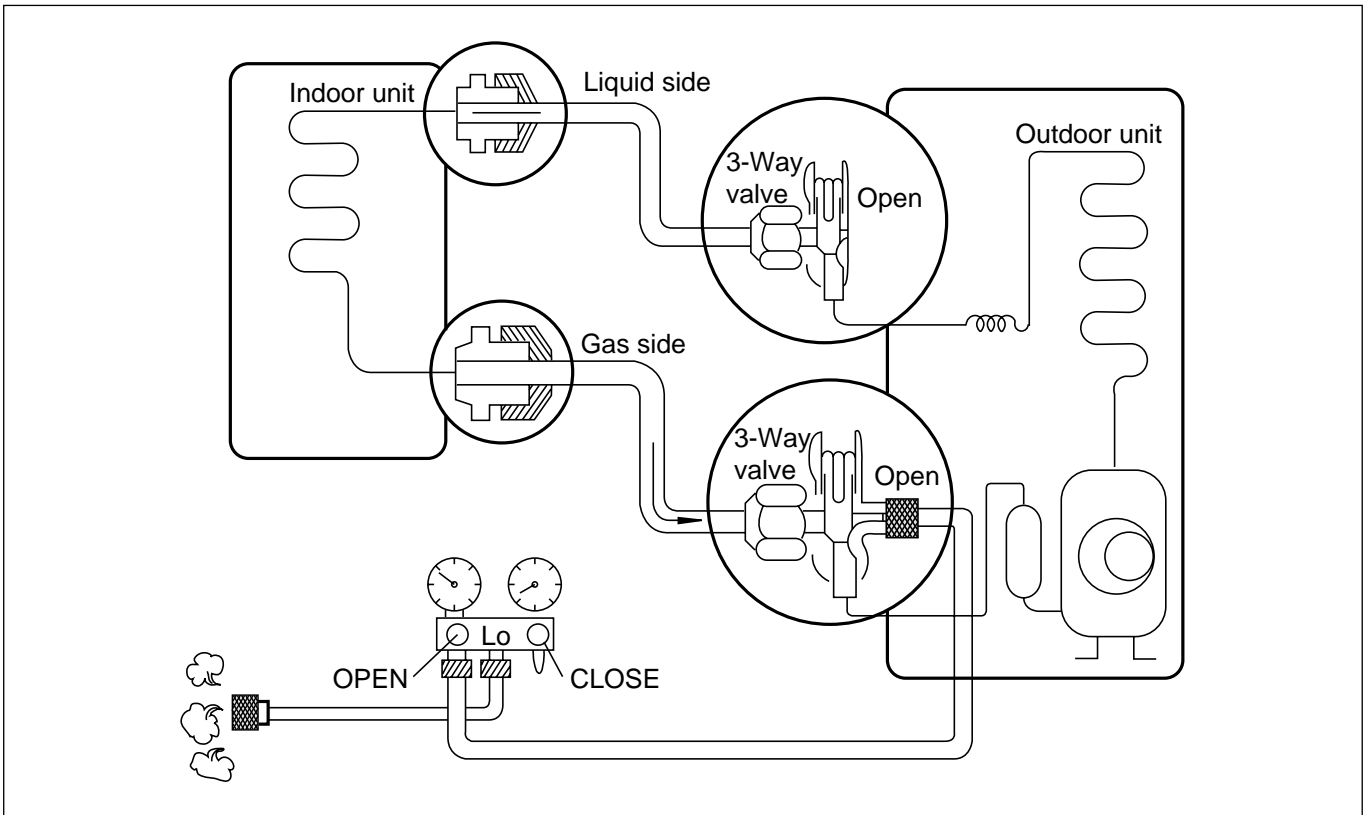

• Procedure

- (1) Confirm that both the 2-way and 3-way valves are set to the back seat.
- (2) Connect the charge set to the 3-way valve's port.
 - Leave the valve on the charge set closed.
 - Connect the charge hose to the service port.
- (3) Open the valve (Lo side) on the charge set and discharge the refrigerant until the gauge indicates 0 kg/cm²G.
 - If there is no air in the refrigerant cycle (the pressure when the air conditioner is not running is higher than 1 kg/cm²G), discharge the refrigerant until the gauge indicates 0.5 to 1 kg/cm²G. If this is the case, it will not be necessary to apply a vacuum.
 - Discharge the refrigerant gradually; if it is discharged too suddenly, the refrigeration oil will also be discharged.

Evacuation

(All amount of refrigerant leaked)

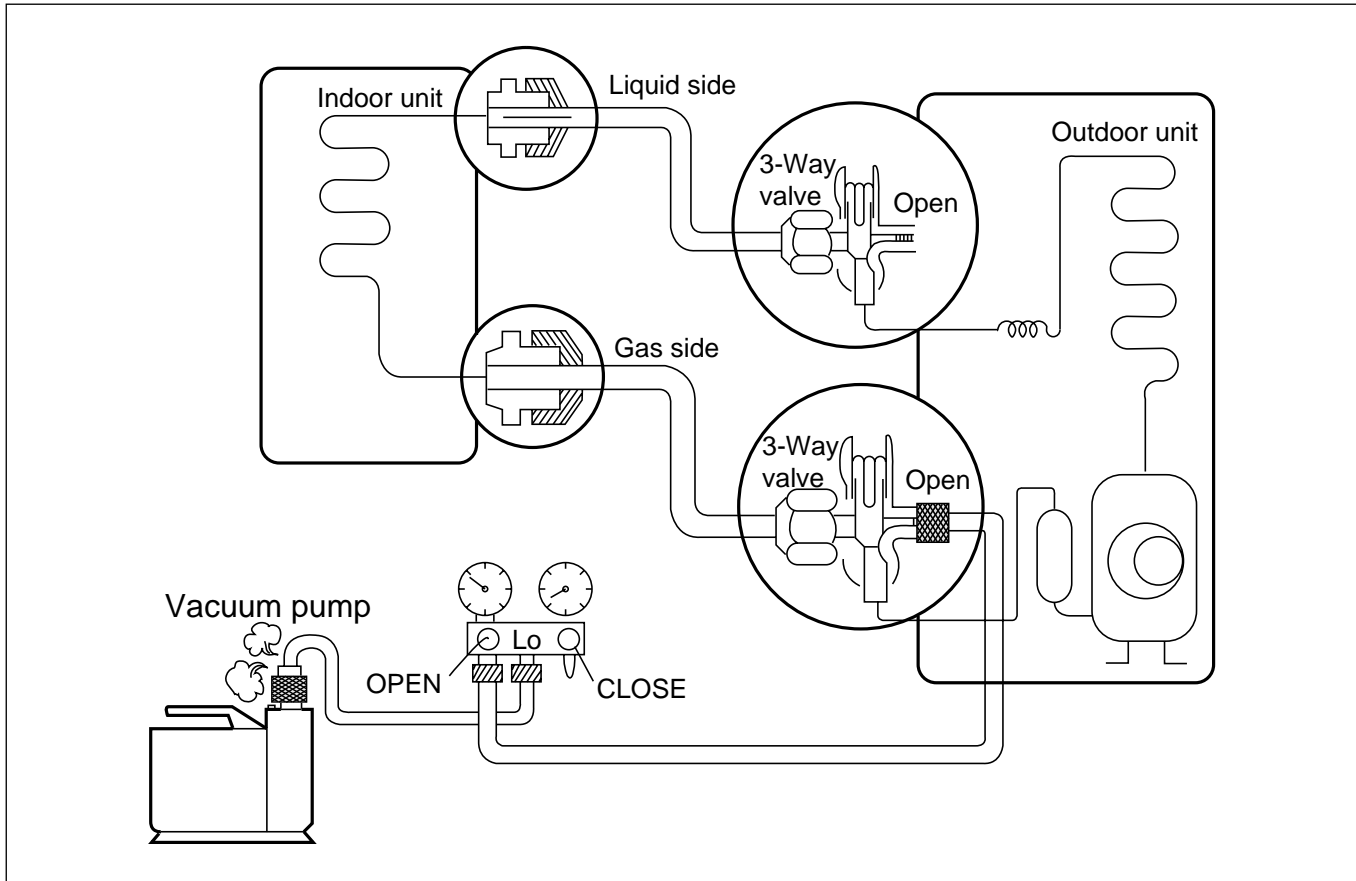

• Procedure

- (1) Connect the vacuum pump to the center hose of charge set center hose
- (2) Evacuation for approximately one hour.
 - Confirm that the gauge needle has moved toward -76 cmHg (vacuum of 4 mmHg or less).
- (3) Close the valve (Lo side) on the charge set, turn off the vacuum pump, and confirm that the gauge needle does not move (approximately 5 minutes after turning off the vacuum pump).
- (4) Disconnect the charge hose from the vacuum pump.
 - Vacuum pump oil.
 - If the vacuum pump oil becomes dirty or depleted, replenish as needed.

Gas Charging

(After Evacuation)

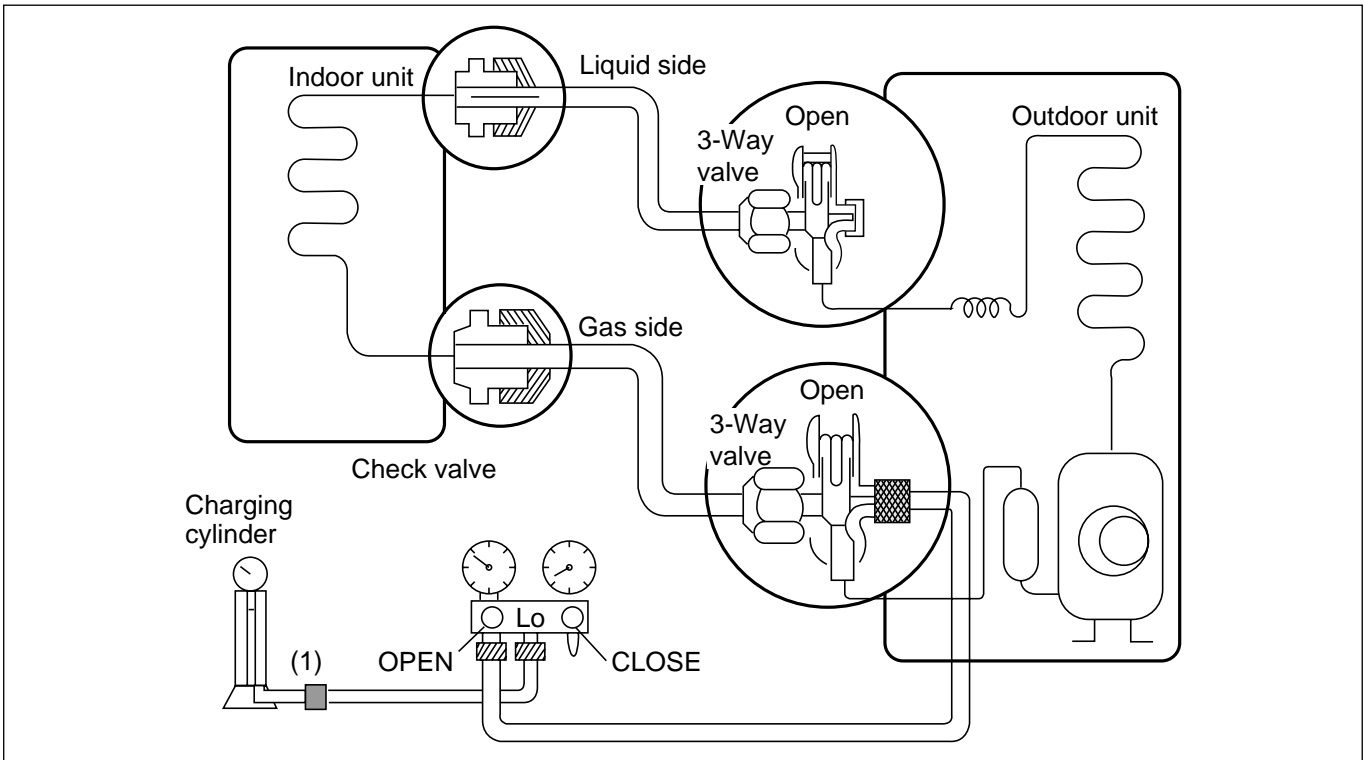

• Procedure

(1) Connect the charge hose to the charging cylinder.

- Connect the charge hose which you dis-connected from the vacuum pump to the valve at the bottom of the cylinder.
- If you are using a gas cylinder, also use a scale and reverse the cylinder so that the system can be charged with liquid.

(2) Purge the air from the charge hose.

- Open the valve at the bottom of the cylinder and press the check valve on the charge set to purge the air. (Be careful of the liquid refrigerant). The procedure is the same if using a gas cylinder.

(3) Open the valve (Lo side on the charge set and charge the system with liquid refrigerant.

- If the system can not be charged with the specified amount of refrigerant, it can be charged with a little at a time (approximately 150g each time) while operating the air conditioner in the cooling cycle; however, one time is not sufficient, wait approximately 1 minute and then repeat the procedure (pumping down-pin).

This is different from previous procedures. Because you are charging with liquid refrigerant from the gas side, absolutely do not attempt to charge with larger amounts of liquid refrigerant while operating the air conditioner.

(4) Immediately disconnect the charge hose from the 3-way valve's service port.

- Stopping partway will allow the gas to be discharged.
- If the system has been charged with liquid refrigerant while operating the air conditioner turn off the air conditioner before disconnecting the hose.

(5) Mount the valve stem nuts and the service port nut.

- Use torque wrench to tighten the service port nut to a torque of 1.8 kg.m.
- Be sure to check for gas leakage.

Cycle Parts

Trouble analysis

1. Check temperature difference between intake and discharge air and operating current.

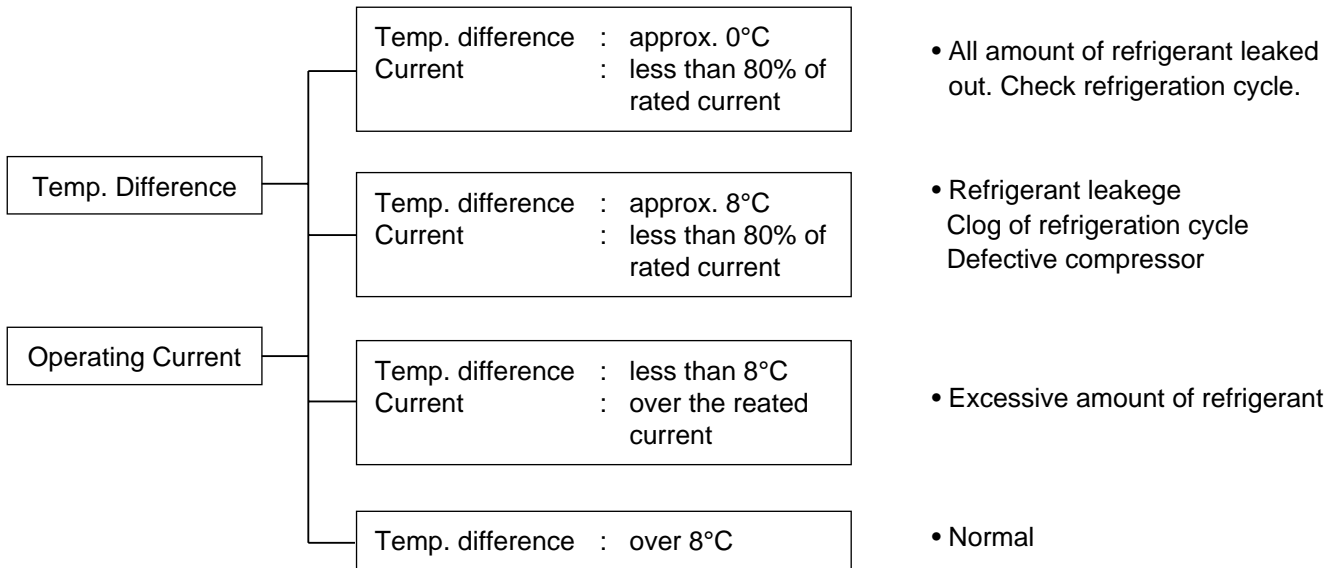

NOTICE

Temperature difference between intake and discharge air depends on room air humidity. When the room air humidity is relatively higher, temperature difference is smaller. When the room air humidity is relatively lower temperature difference is larger.





2. Check temperature and pressure of refrigeration cycle.

Suction pressure (Compared with the normal value)	Temperature (Compared with the normal valve)	Cause of Trouble	Description
Higher	High	Defective compressor Defective 4-way reverse valve	Current is low.
	Normal	Excessive amount of refrigerant	High pressure does not quickly rise at the beginning of operation.
Lower	Higher	Insufficient amount of refrigerant (Leakage)	Current is low.
		Clogging	Current is low.

NOTICE

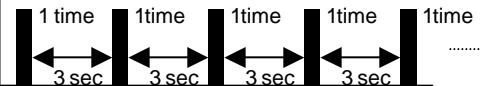
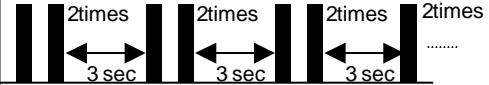
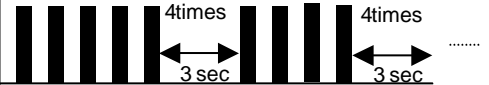
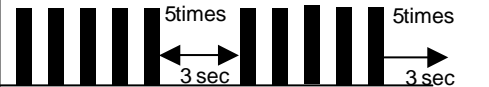
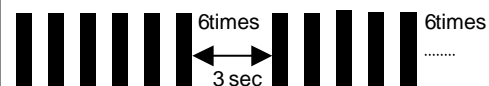
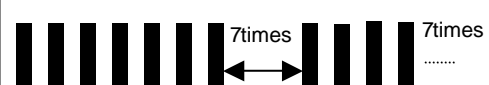
- The suction pressure is usually 8.5~9.5kg/cm²G(Cooling) at normal condition.
- The temperature can be measured by attaching the thermometer to the low pressure tubing and wrap it with putty.

Self diagnosis Function

Error Code	Error Indicator	Cause of Error	Display		Indoor Operation
			Indoor	Outdoor	
1		<ul style="list-style-type: none"> Indoor Temp. sensor error - Sensor open or short 	O		ON
2		<ul style="list-style-type: none"> Outdoor Temp. sensor error - Sensor open or short 	O	O	ON
4		<ul style="list-style-type: none"> Heat Sink sensor error - Sensor open or short Heat Sink temp is over 95. 	O	O	ON
5		<ul style="list-style-type: none"> Communication error 	O	O	OFF
6		<ul style="list-style-type: none"> DC Peak error 	O	O	SHUT DOWN
7		<ul style="list-style-type: none"> Over current error (CT2) 	O	O	SHUT DOWN
8		<ul style="list-style-type: none"> Indoor fan lock error (BLDC fan model only) 	O		OFF
9		<ul style="list-style-type: none"> Outdoor fan lock error (BLDC fan model only) 	O	O	OFF
10			O	O	ON

1. Error indicator of air conditioner

- 1) Indoor : Operating LED / Outdoor : LED01M(Red) on the outdoor PCB
- 2) 2 more errors occur at same time
 - Air conditioner Off condition : Display the error code of product off cause
 - Air conditioner On condition : Display the prior Error Code

2. Cancellation of Error indicator

- 1) Error Code 1, 2, 3, 4, 10 : Error indicator canceled when cause of error recovered
- 2) Error Code 5, 8, 9 : Keep displaying Error indicator by restarting air conditioner, although cause of error recovered
- 3) Error Code 6, 7 : Error indicator canceled when power reset (Power Cord Off & On)

■ Precaution in Service or Check

Even after stopping the operation of product, it takes some time to discharge the remaining electricity of the electrolytic capacitor that was charged. Before starting a checking or repairing job, pull out the plug out of the outlet and make sure that the lamp on the control board outdoor unit is off.

■ The Diagnosis Procedure

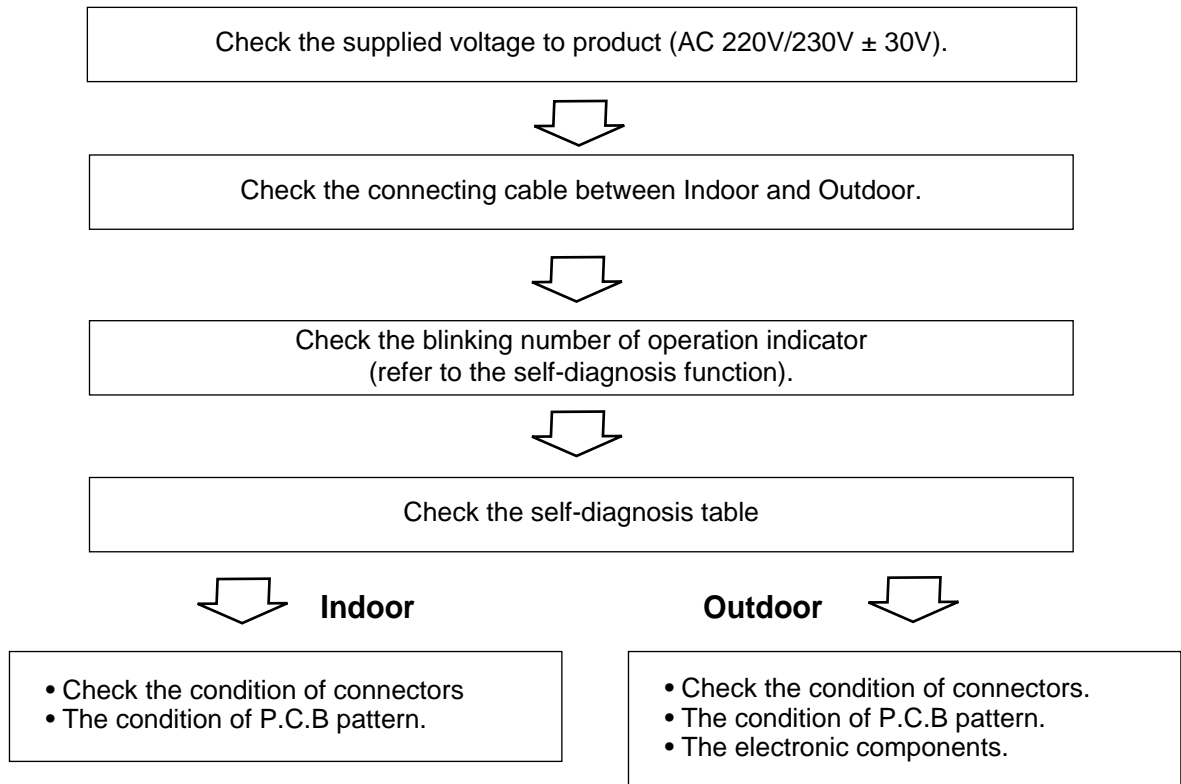

Electronic Parts

* Refer to electronic control device drawing & schematic diagram.

Trouble 1 The Product doesn't operate at all.

Turn off the main power and wait to 10 seconds



Turn on the main power again.



Does "Beeping" sound is made from the indoor unit?



Check the voltage of power(AC220V/AC240V, 50Hz).

- The voltage of main power.
- The voltage applied to the unit.
- The connecting method of Indoor/Outdoor connecting cable (each color)
- The P.C.B. Ass'y
(Fuse, Noise Filter, Power Module, Bridge Diode, etc.)



- Primarily, the operating condition of Micom is O.K.



- Check CN-DISP1
CN-DISP2 of indoor PCB

The operation check of the Indoor P.C.B. Ass'y

Procedure	Specification	Remedy
1) The input voltage of power module.	1) AC230V \pm 30V : Check the rated voltage	1) Check the power outlet.
2) The output voltage of power module.	2) 12V \pm 3V	2) Replace P.C.B Ass'y
4) IC04D(7805)	4) DC5V	4) Replace P.C.B Ass'y
5) IC01A(KIA7036)	5) The voltage of micom pin 19 : DC4.5V \uparrow	5) Replace P.C.B Ass'y

Trouble 2 Product doesn't operate with the remote controller.

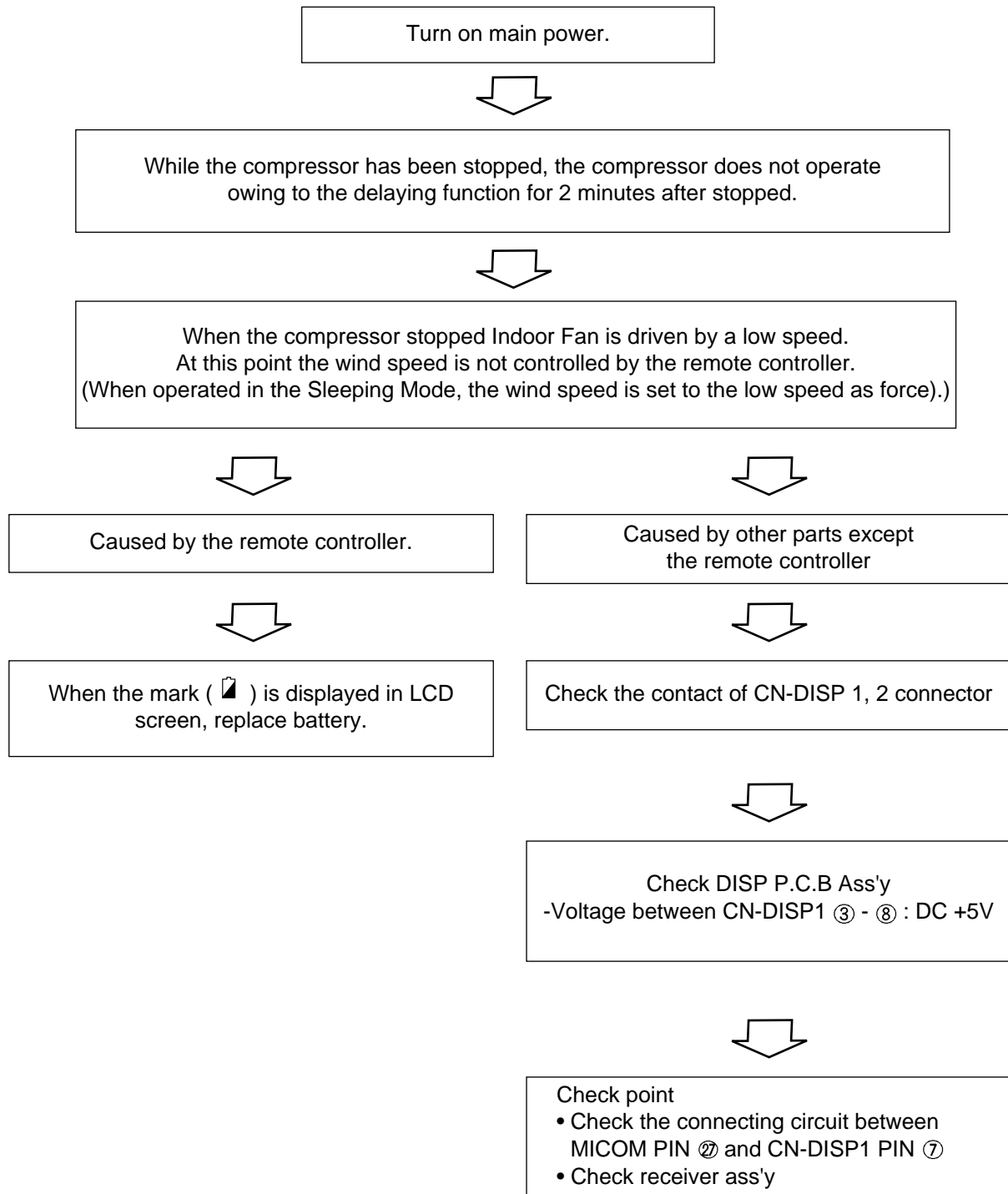

Troubleshooting for error code

Error code	Description	Cause of error
1	Indoor TH. is short or open	<ul style="list-style-type: none"> Indoor TH. (sensor) is short or open Indoor TH. (sensor) is not connected to the indoor pcb assembly Damage or defect on the sensing circuit of indoor pcb assembly. (R01H, R02H, R03H, R04H, C01H, C02H)

Check flow

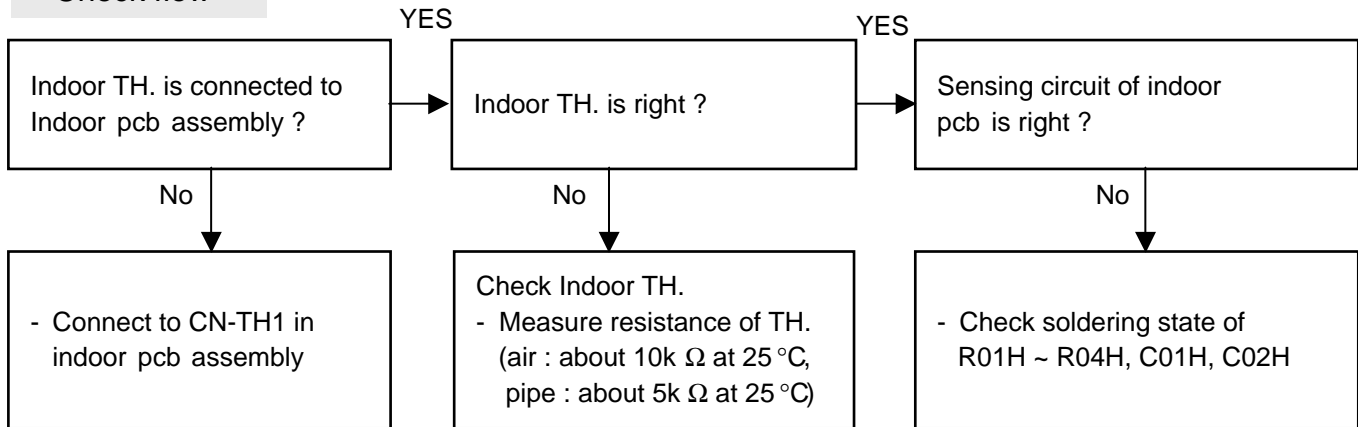

Error code	Description	Cause of error
2	Outdoor TH. is short or open	<ul style="list-style-type: none"> Outdoor TH. (sensor) is short or open Outdoor TH. (sensor) is not connected to the outdoor pcb assembly Damage or defect on the sensing circuit of outdoor pcb assembly. (R03H~R06H, C02H, C03H)

Check flow

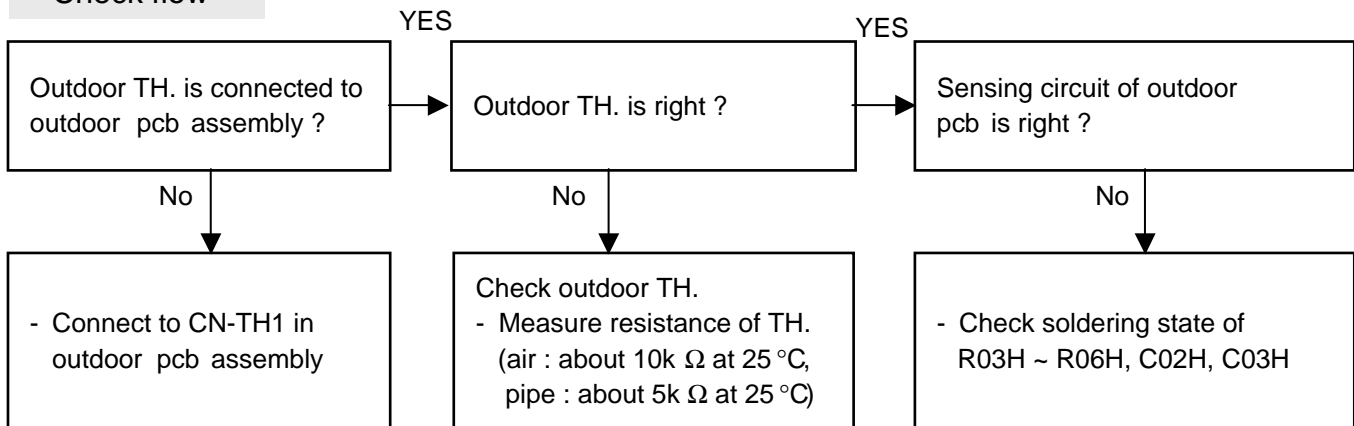

• 9K / 12K

Error code	Description	Cause of error
4	Heat-sink Temp. is over 95°C Heat-sink TH. is open or short	<ul style="list-style-type: none"> Heat-sink TH. is damaged(short or open). Heat-sink Temp. is over 95°C Damage or defect on the sensing circuit of outdoor pcb assembly. (R01H, R02H, C01H)

Check flow

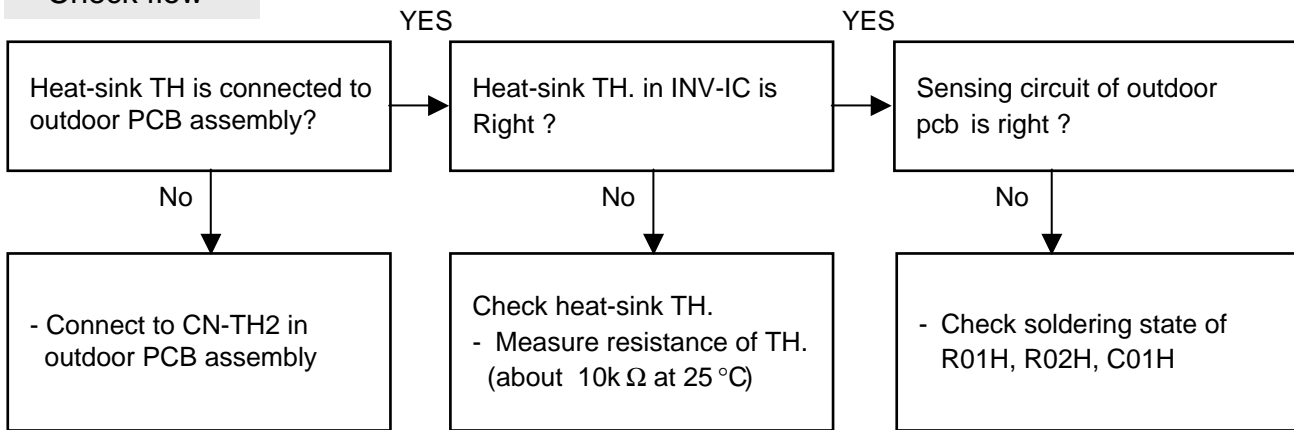

• 18K

Error code	Description	Cause of error
4	Heat-sink Temp. is over 95°C Heat-sink TH. in outdoor pcb is open or short	<ul style="list-style-type: none"> Heat-sink TH. in outdoor pcb is open or short Heat-sink Temp. is over 95°C Damage or defect on the sensing circuit of outdoor pcb assembly. (R01H, R02H, C01H)

Check flow

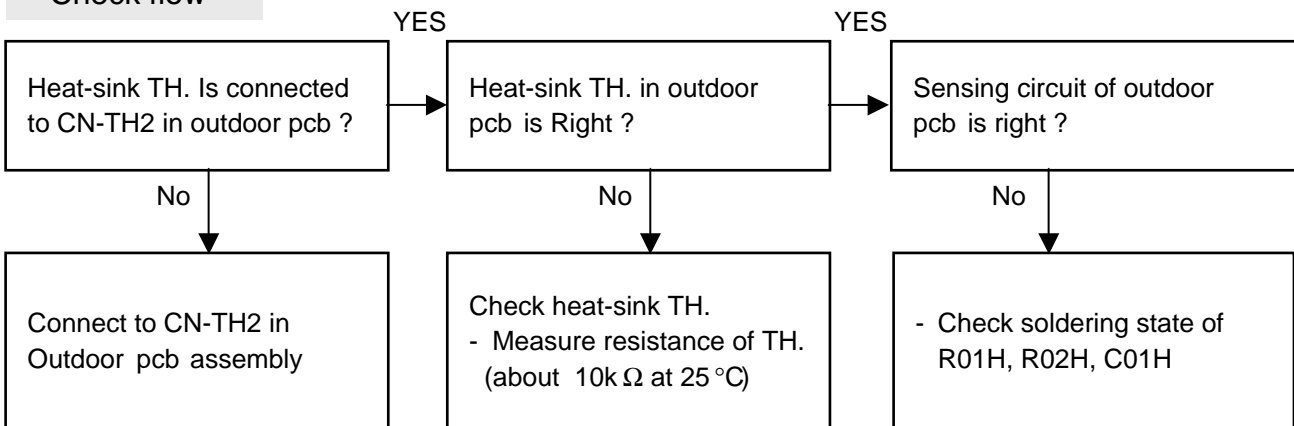

Error code	Description	Cause of error
5	Communication Error	<ul style="list-style-type: none"> • Wrong or missing wiring between indoor and outdoor unit cable • Defect of communication components in indoor pcb assembly • Defect of communication components in outdoor pcb assembly • Defect of power supply components in outdoor pcb assembly • No ground connection in air conditioner unit (affected by noise in power source)

Check flow

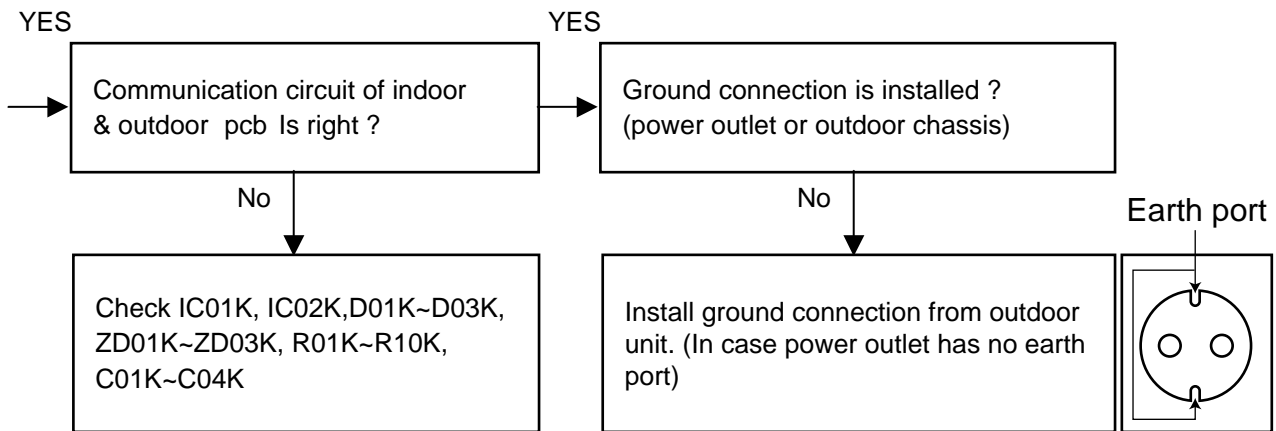
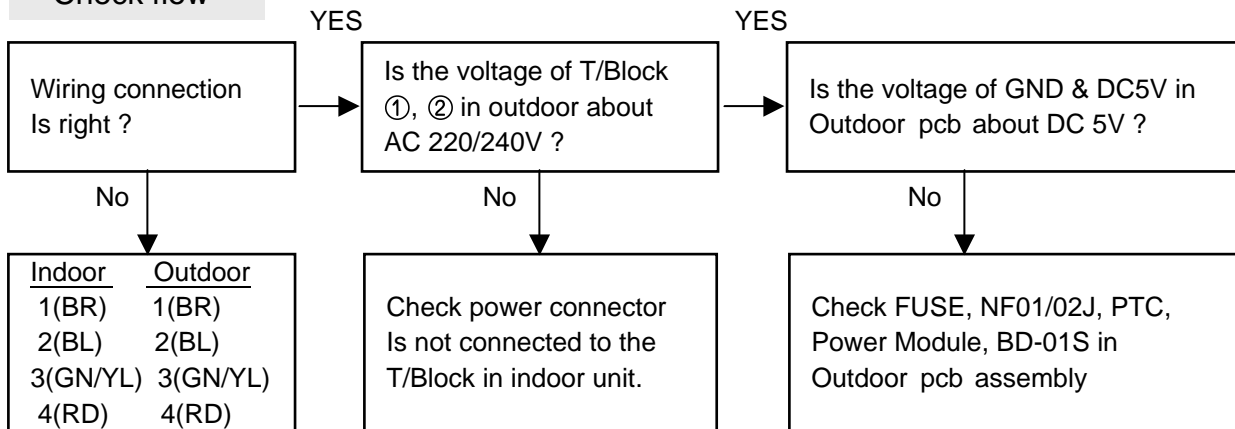

Error code	Description	Cause of error
6	DC Peak Error	<ul style="list-style-type: none"> Supplied power is not normal Comp Connector (CN-U,V,W) is disconnected or inserted to wrong position Compressor is damaged (coil short) → replace compressor Too much Refrigerant Defect in outdoor pcb assembly → replace pcb assembly

Check flow

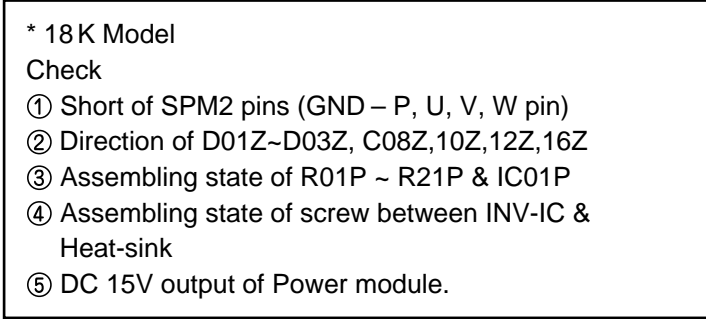
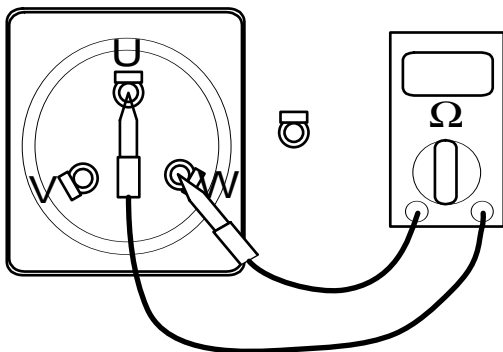
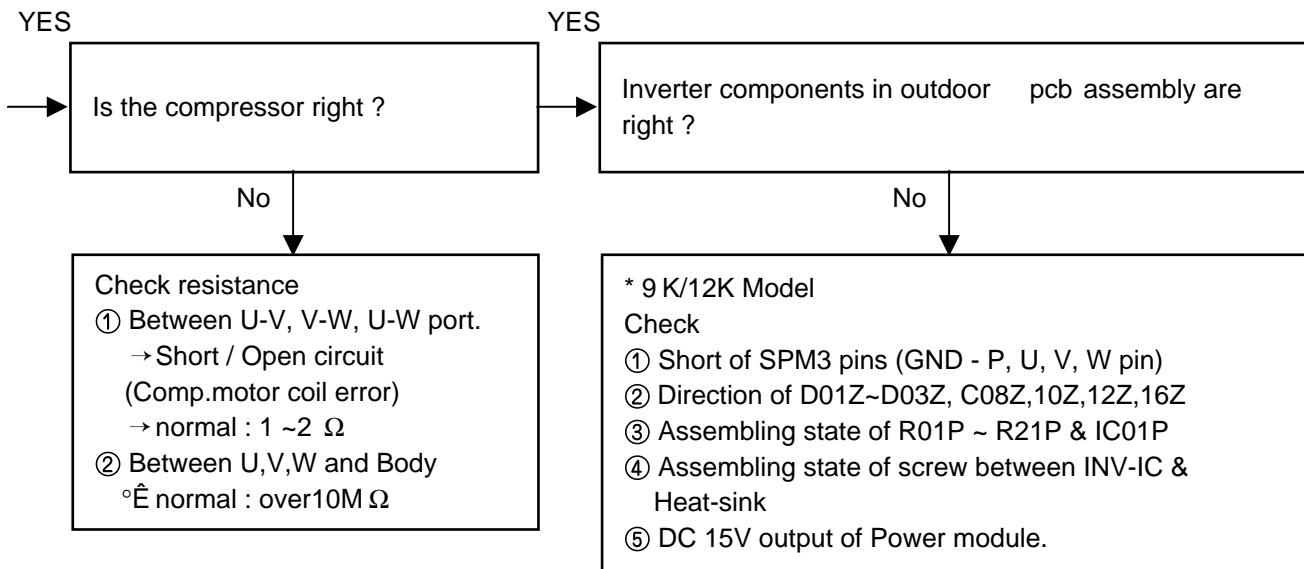
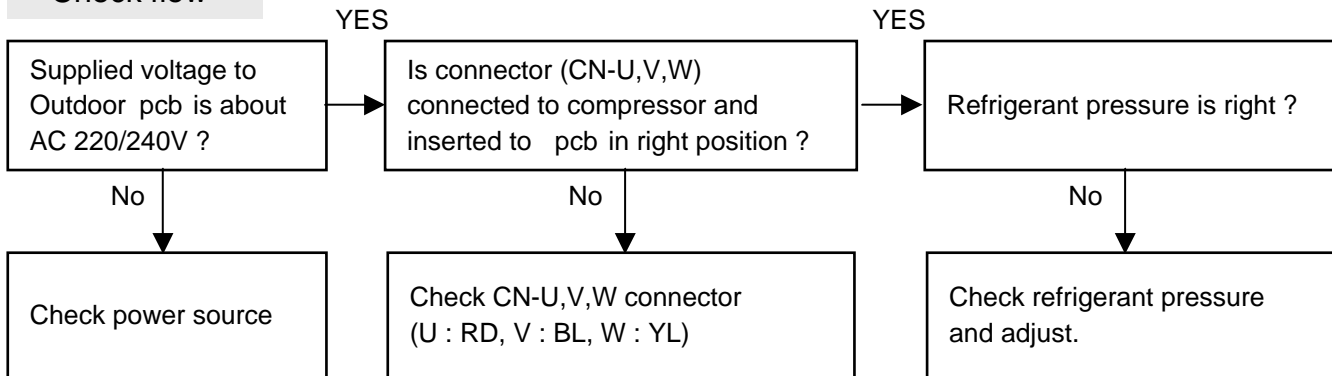

Error code	Description	Cause of error
7	Over current Error (CT2)	<ul style="list-style-type: none"> • Supplied power is not normal • Indoor/outdoor fan is locked • Too much refrigerant • Defect in current sensing circuit in outdoor pcb assembly

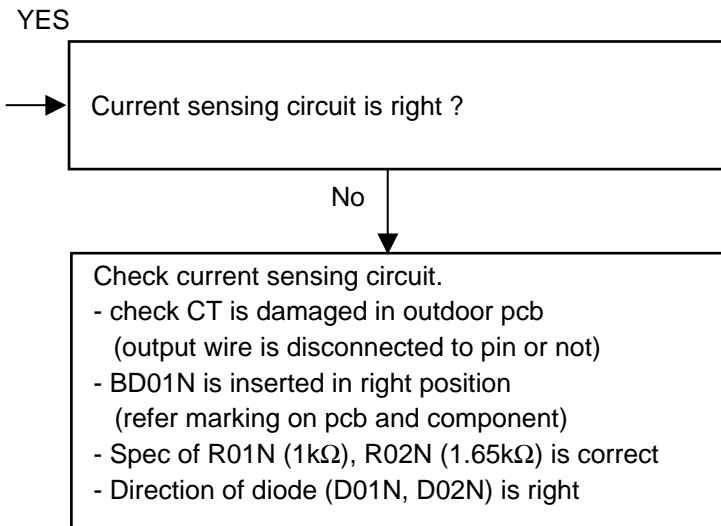
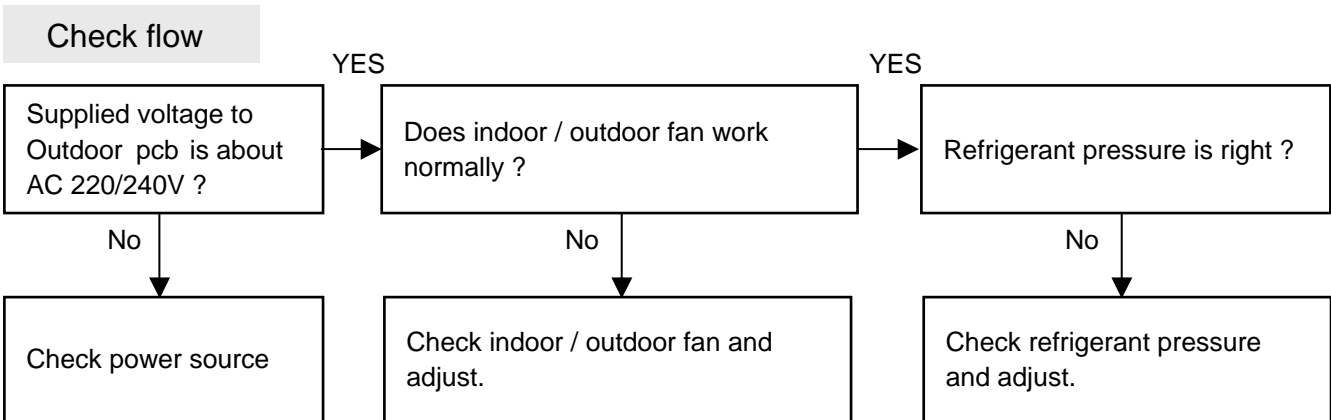

Error code	Description	Cause of error
8	Indoor fan is locked (BLDC fan model only)	<ul style="list-style-type: none"> Indoor fan is locked or separated Fan connector is not connected to indoor pcb assembly Defective in DC-fan driving circuit

Check flow

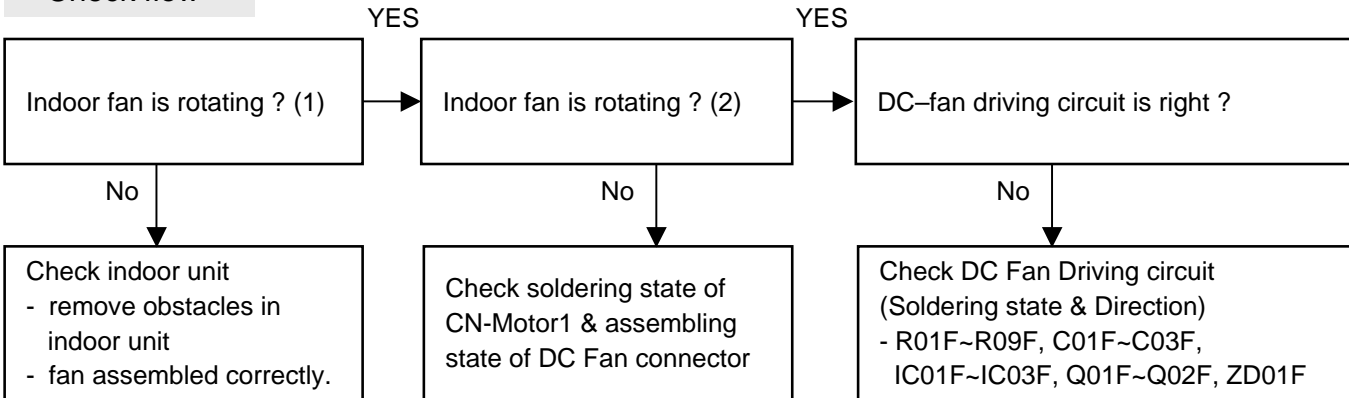

Error code	Description	Cause of error
9	Outdoor fan is locked (BLDC fan model only)	<ul style="list-style-type: none"> Outdoor fan is locked by an obstacle (ex : branch of tree, bar...etc) Fan connector is not connected to outdoor pcb assembly Defective in DC-fan driving circuit

Check flow

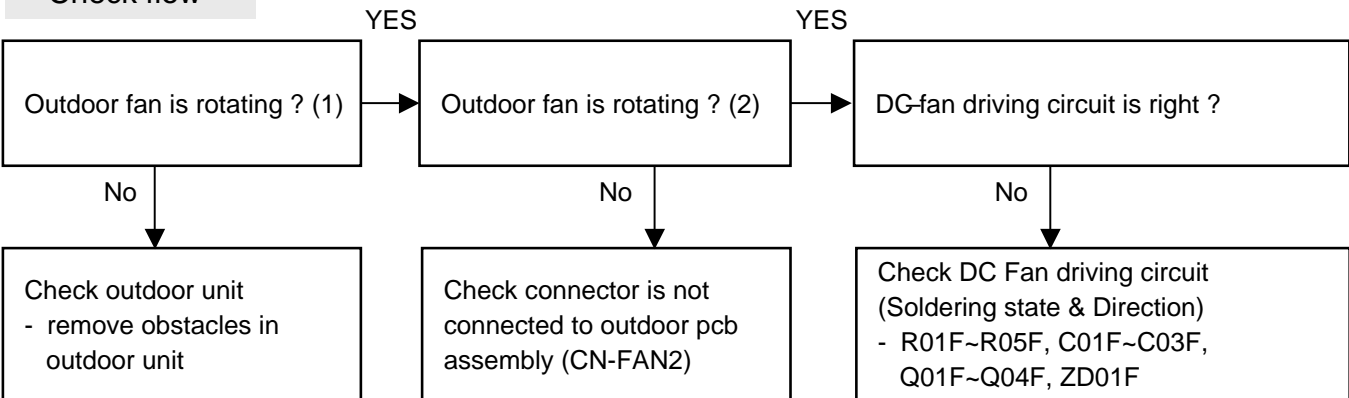

Error code	Description	Cause of error
10	D-Pipe TH. is short or open	<ul style="list-style-type: none"> • D_pipe TH. is short or open • D_pipe TH. is not connected to the outdoor pcb assembly • Damage or defect on the sensing circuit of outdoor pcb assembly

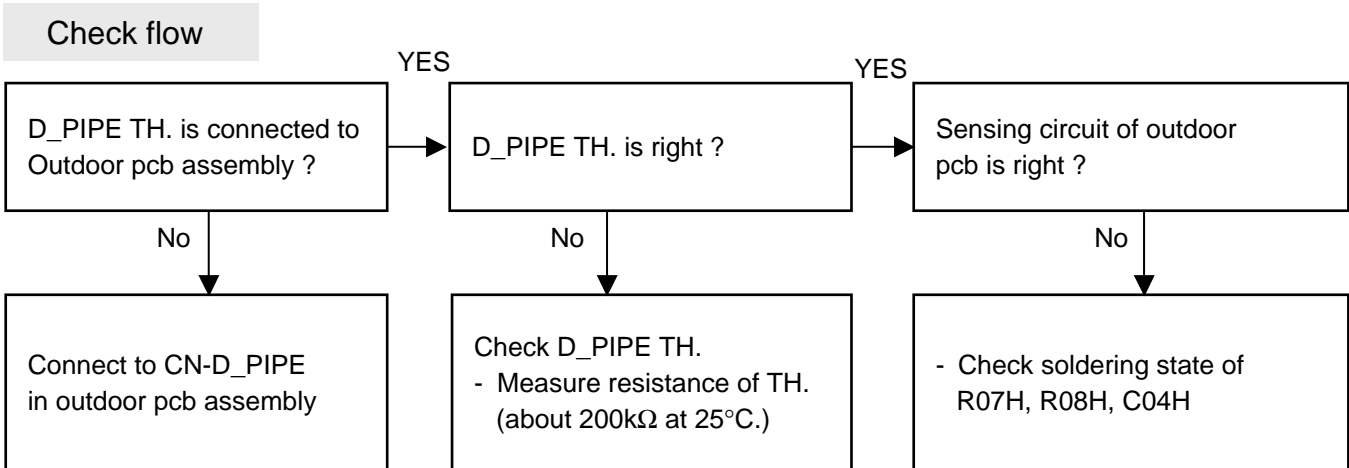

Schematic Diagram

Wiring Diagram

Indoor Unit

Models: AS-W0964DH0, AS-W0964GH0

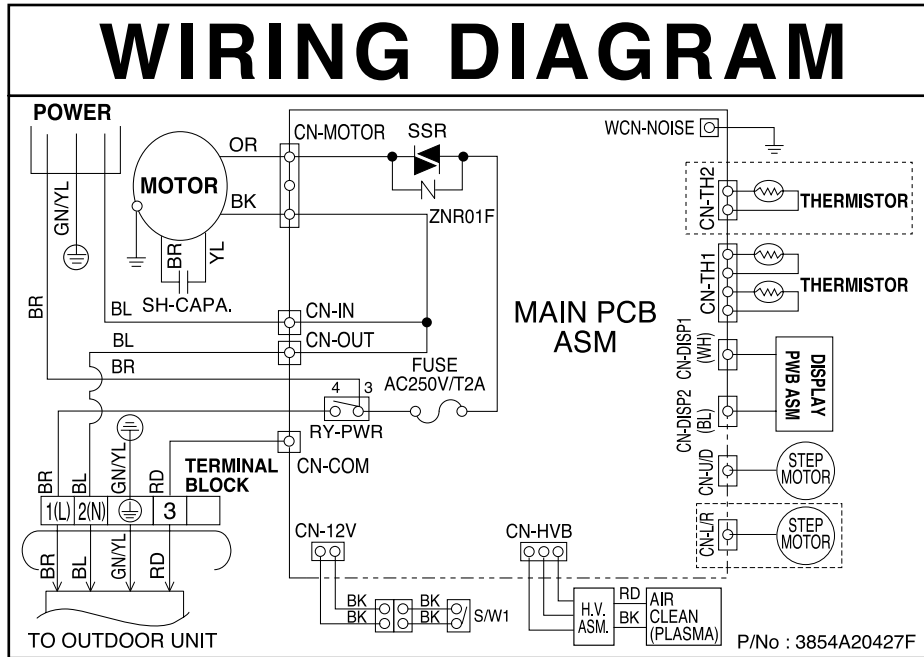

Models: AS-W1264DH0, AS-W1865DH0, AS-W1264GH0, AS-W1224DH0, AS-W1424DH0, AS-W1825DH0

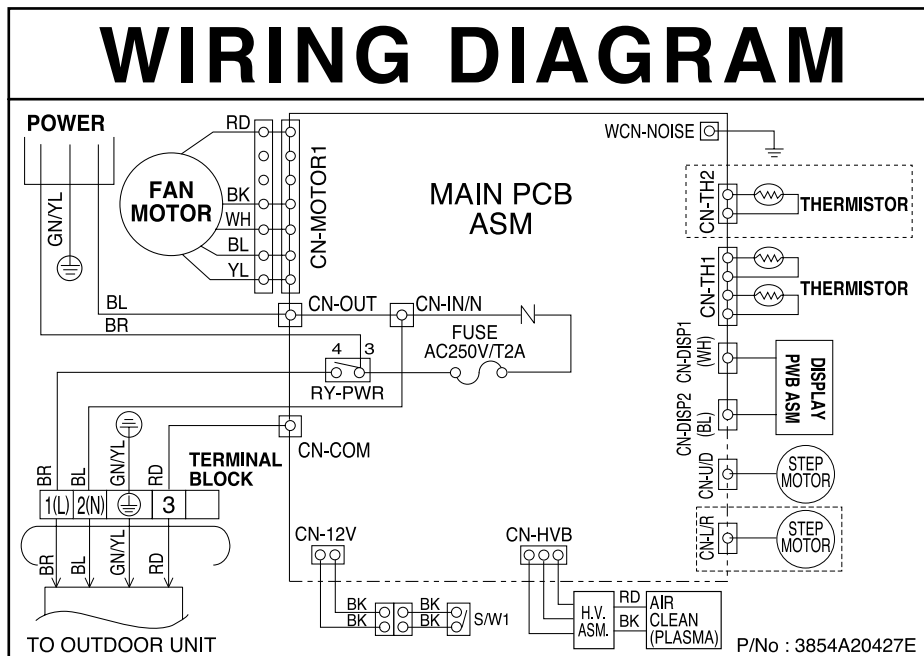

Outdoor Unit

Models: AS-W0964DH0, AS-W0964GH0

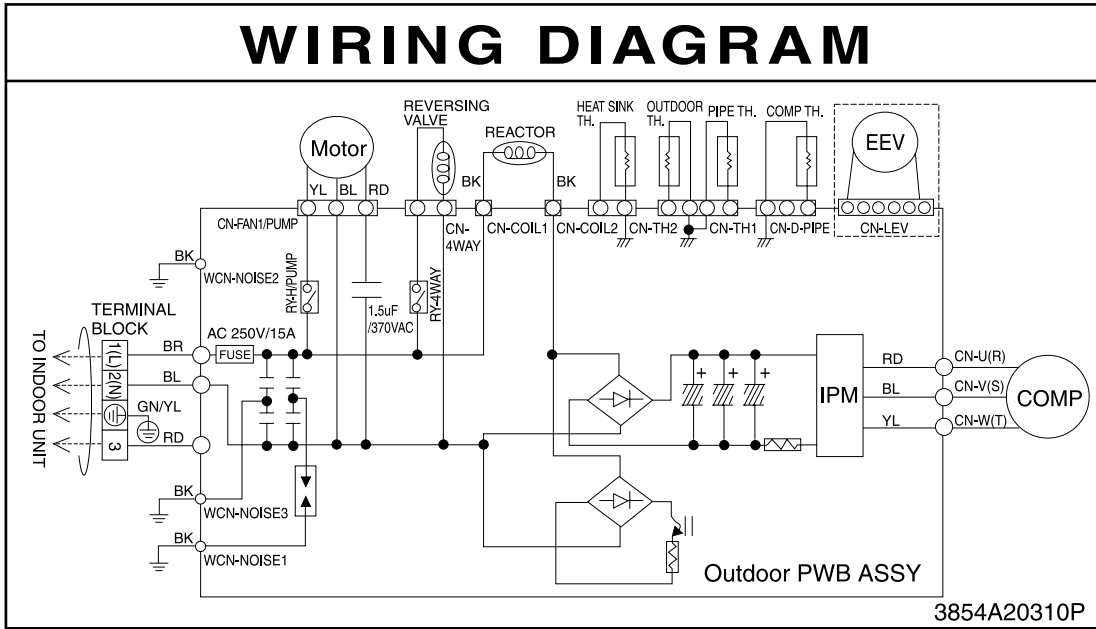

Models: AS-W1264DH0, AS-W1264GH0, AS-W1224DH0, AS-W1424DH0

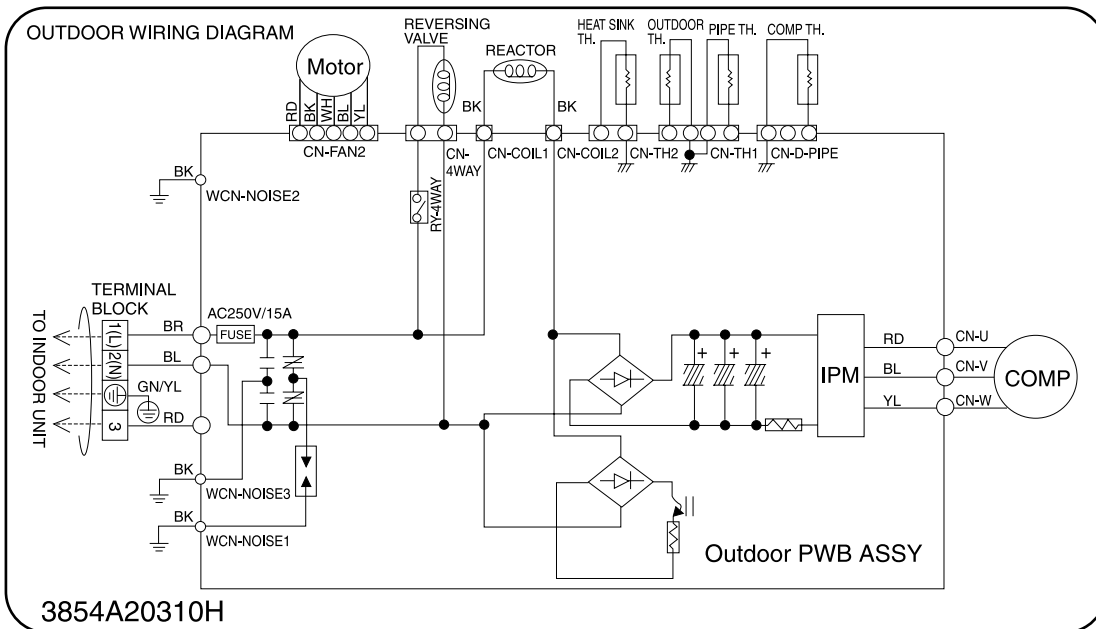

Models: AS-W1865DH0, AS-W1825DH0

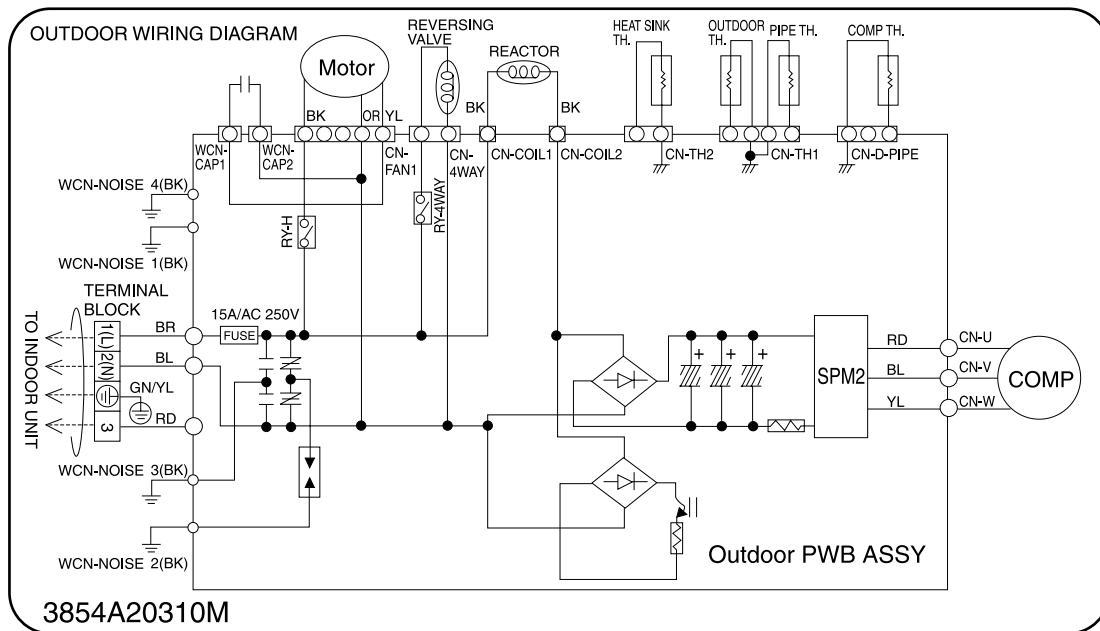

Components Location

Indoor Unit

Models: AS-W1264DH0, AS-W1865DH0, AS-W1264GH0, AS-W1224DH0, AS-W1424DH0, AS-W1825DH0

• TOP VIEW

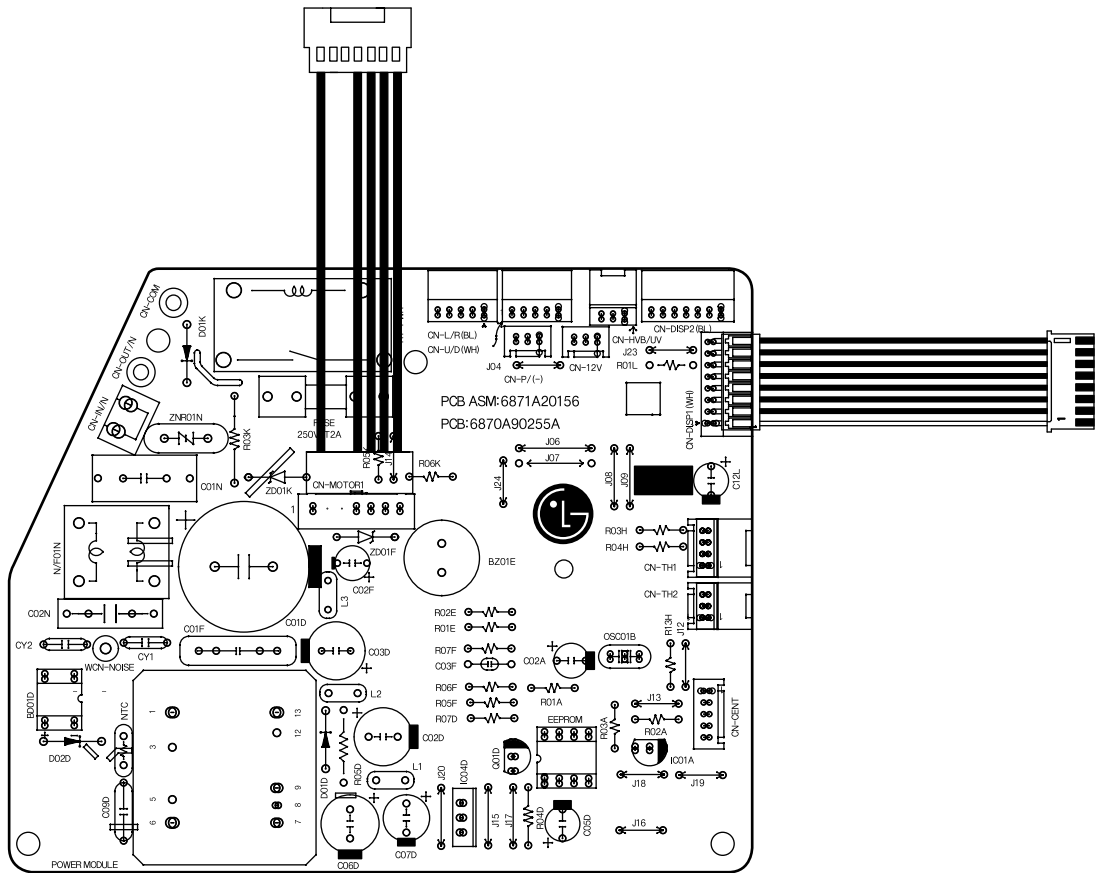

• BOTTOM VIEW

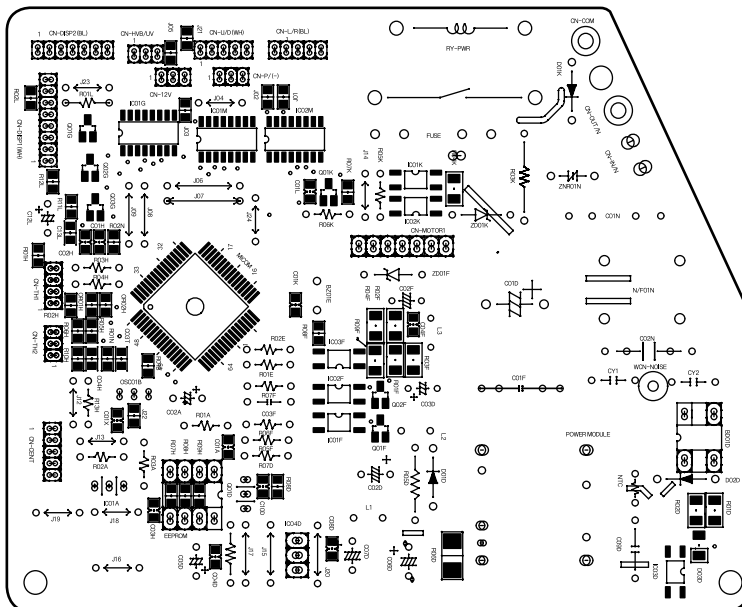

Models: AS-W0964DH0, AS-W0964GH0

• TOP VIEW

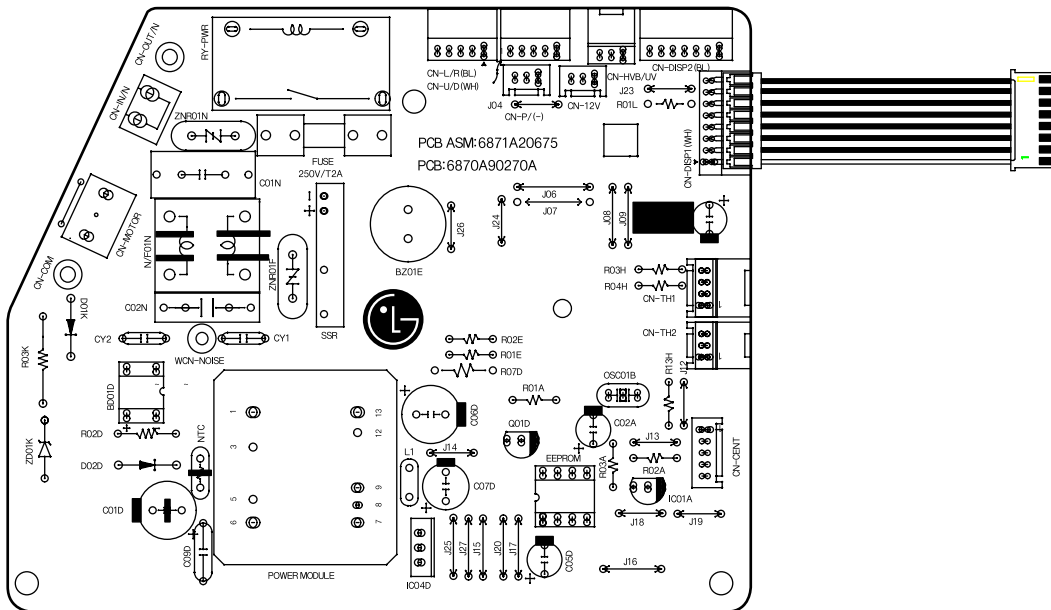

• BOTTOM VIEW

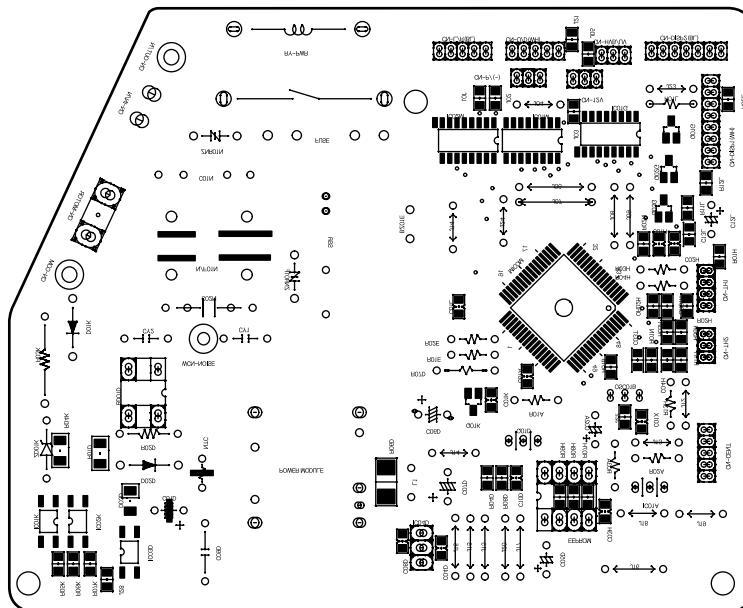

Outdoor Unit

Models: AS-W0964DH0, AS-W1264DH0, AS-W0964GH0, AS-W1264GH0, AS-W1224DH0, AS-W1424DH0

• TOP VIEW

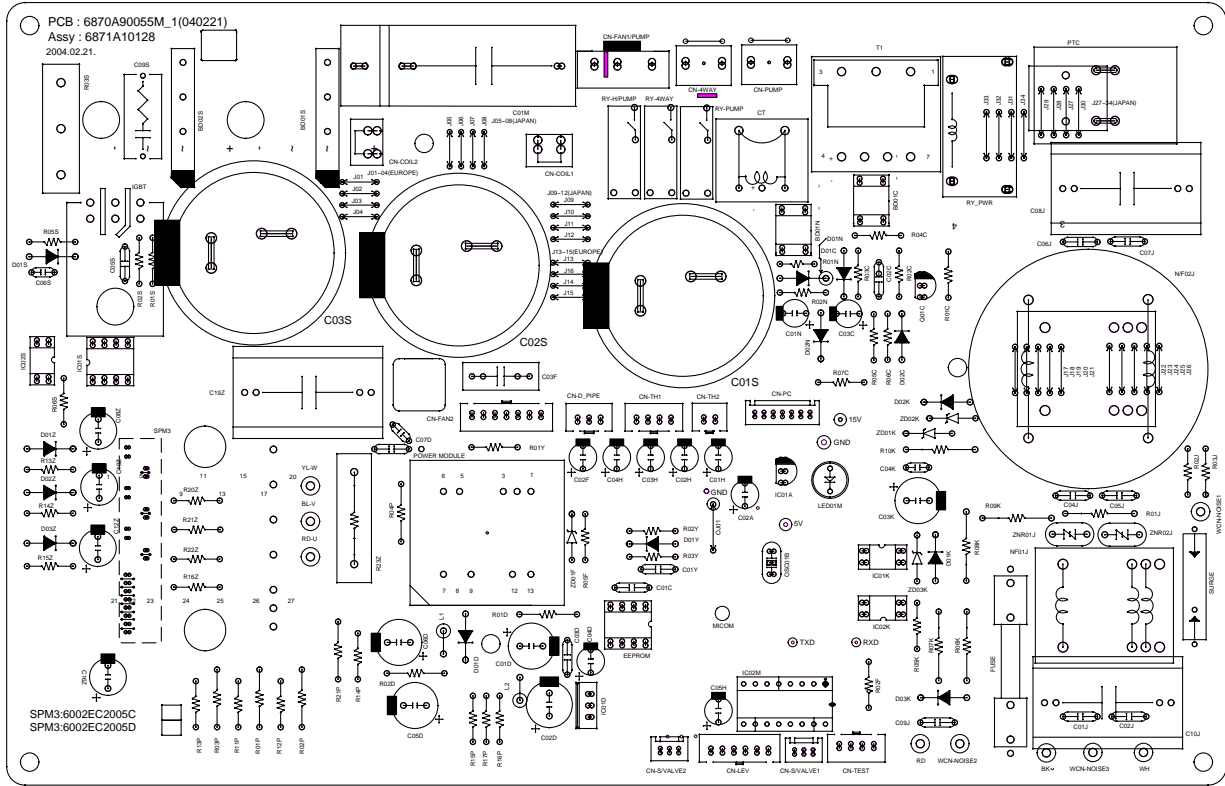

• BOTTOM VIEW

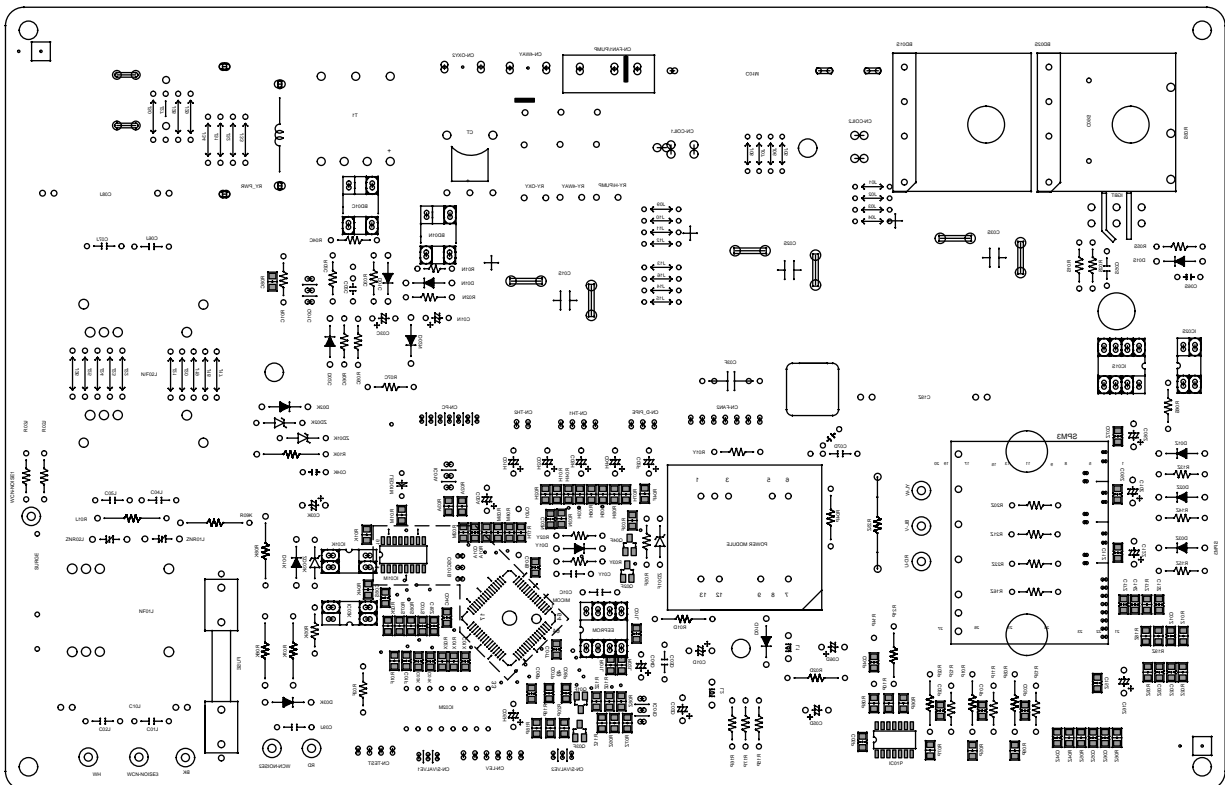

Models: AS-W1865DH0, AS-W1825DH0

• TOP VIEW

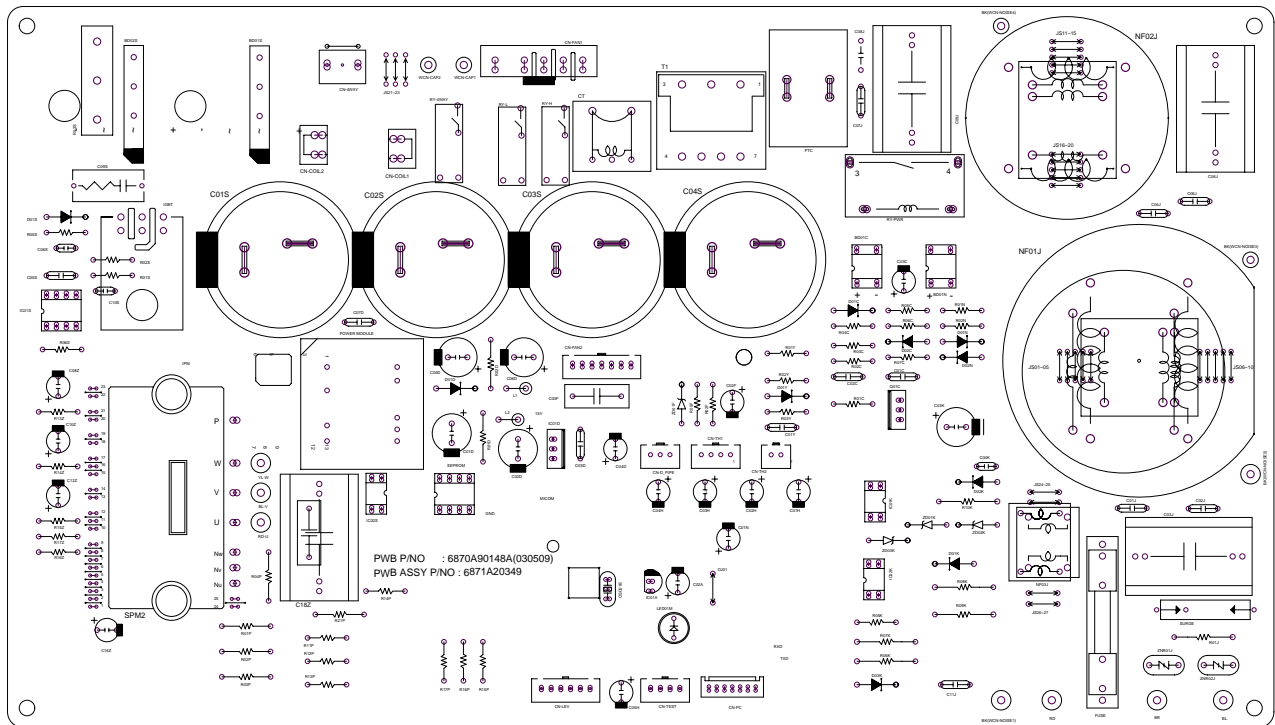

• BOTTOM VIEW

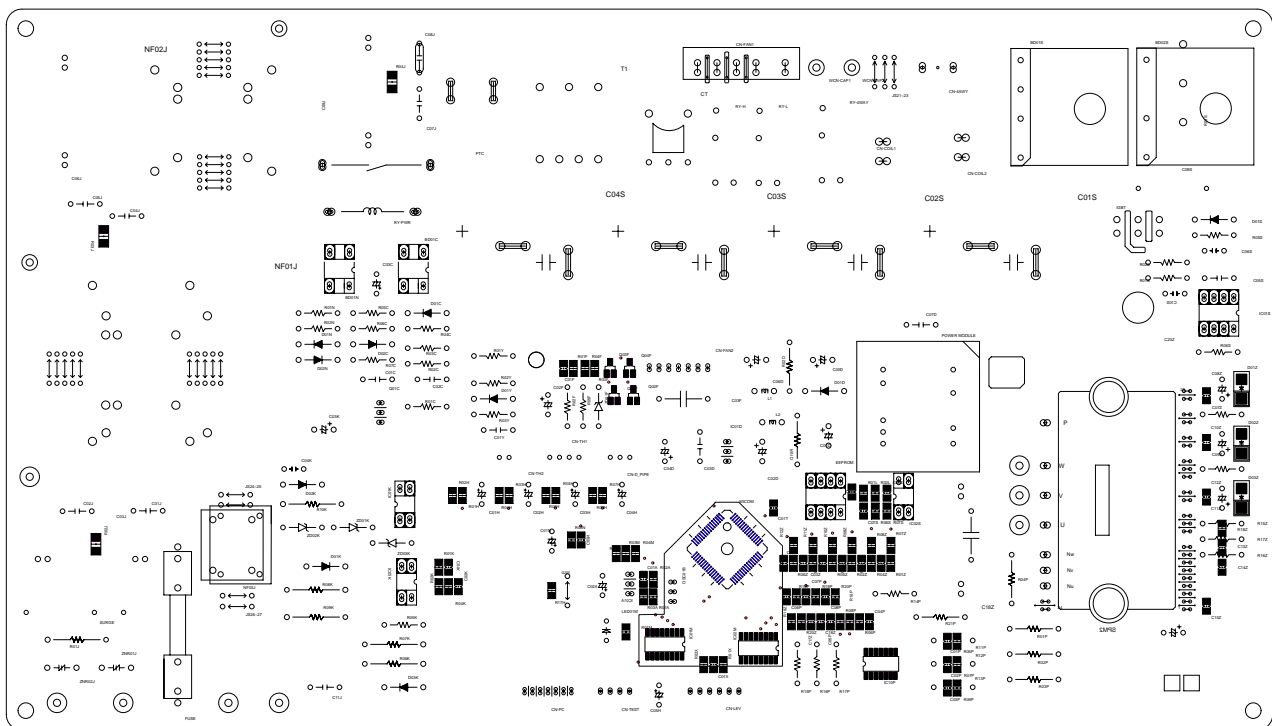

DISPLAY ASSEMBLY

– 6871A20574A

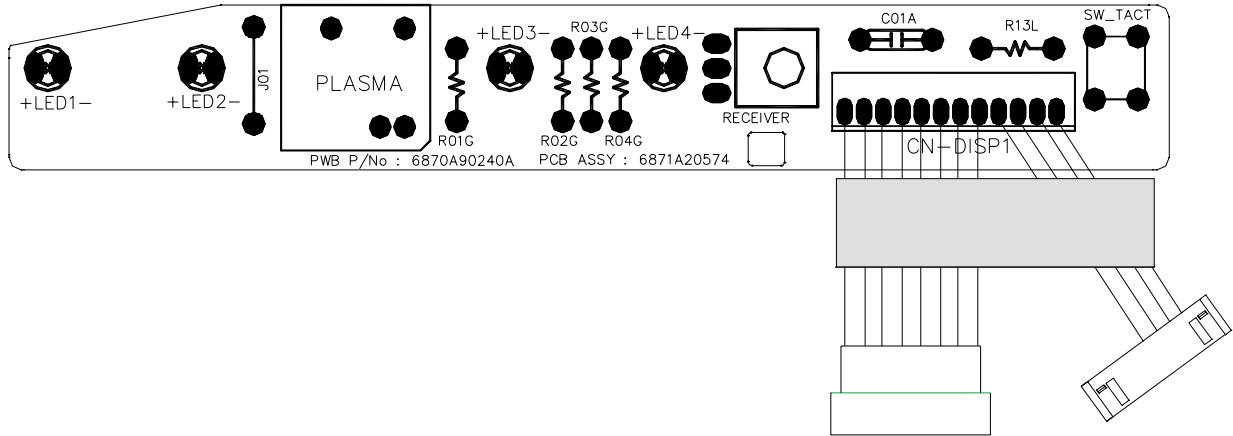

– 6871A20624A

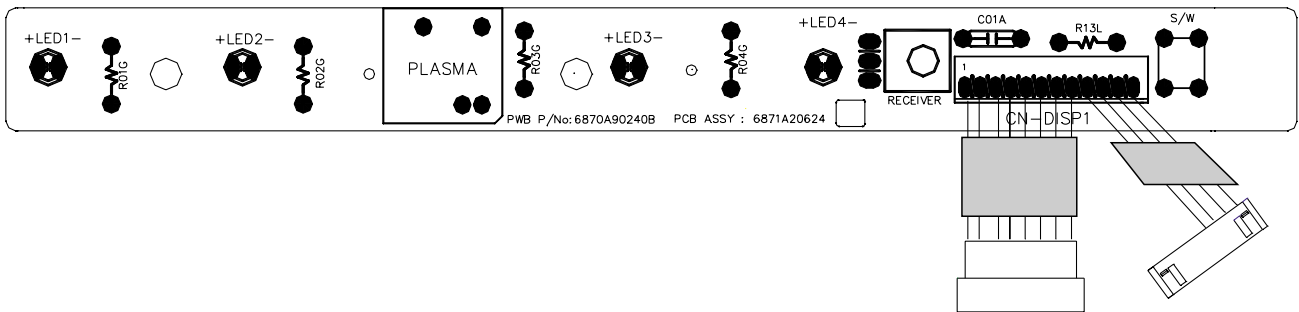

Product Specifications

Table-1

Item	Model Name		AS-W0964DH0 AS-W0964GH0	AS-W1264DH0 AS-W1264GH0	AS-W1865DH0
	Unit				
Cooling Capacity	MIN	W	1,758	1,143	2,755
		kcal/h.(W)	1,512	983	2,369
		Btu/h.	6,000	3,100	9,400
	Type	W	2,637	3,516	5,274
		kcal/h.(W)	2,268	3,024	4,536
		Btu/h.	9,000	12,000	18,000
	Max	W	3,033	4,043	6,096
		kcal/h.(W)	2,608	3,478	5,242
		Btu/h.	10,350	13,800	20,800
Heating Capacity	MIN	W	1,465	879	1,406
		kcal/h.(W)	1,260	756	1,210
		Btu/h.	5,000	3,000	4,800
	Type	W	3,296	4,043	6,065
		kcal/h.(W)	2,835	3,478	5,216
		Btu/h.	11,250	13,800	20,700
	Max	W	3,810	4,659	6,651
		kcal/h.(W)	3,276	4,007	5,720
		Btu/h.	13,000	15,900	22,700
	IN:20°C,Out:-10°C(Heater ON)	Btu/h.	-	-	-
	IN:20°C,Out:-10°C(Heater OFF)	Btu/h.	-	-	-
Power Input	Cooling	W	690	970	1,640
	Heating	W	910	1,120	1,680
	Heating(-10°C,Heater ON)	W	-	-	-
	Heating(-10°C,Heater OFF)	W	-	-	-
Running Current	Cooling	A	3.4	4.2	7
	Heating	A	4.2	5.1	8
	Heating(-10°C,Heater ON)	A	-	-	-
	Heating(-10°C,Heater OFF)	A	-	-	-
Starting Current	Cooling	A	3.4	4.2	7.5
	Heating	A	4.2	5.1	8.5
EER	Cooling	kcal/hW	3.29	3.29	2.8
		Btu/h.W	13.04	13.04	10.98
	Heating	kcal/hW	3.12	3.12	3.11
		Btu/h.W	10.36	12.32	12.32
COP	Cooling	W/W	3.82	3.82	3.22
	Heating	W/W	3.62	3.61	3.61
Power Supply		∅, V, Hz	1,220-240,50	1,220-240,50	1,220-240,50
Power Factor		%	97	97	97
Air Circulation	Indoor,Max	m ³ /min(CFM)	7.2(254)	8.7(307)	13.0(459)
	Outdoor,Max	m ³ /min(CFM)	26(918)	26(918)	42(1483)
Moisture Removal		l/h.(pts/h.)	1.4(2.94)	1.5(3.2)	2.12
Noise Level (Sound Pressure,1m)	Indoor,High	dB(A)±3	38	40	42
	Med.	dB(A)±3	35	37	-
	Low	dB(A)±3	29	31	36
	Outdoor,Max	dB(A)±3	48	49	55
Refrigerant(R410A)Charge			810(26.5)	845(28.5)	1200(40.8)
Power Cord		AWG#:P*mm ²	16:3*1.0	16:3*1.0	12:3*2.5
Connecting Cable		AWG#:P*mm ²	16:4*1.0	16:4*1.0	12:4*2.5
Connecting Tube (∅. Socket Flare)	Liquid Side	mm(in)	6.35(1/4)	6.35(1/4)	6.35(1/4)
	Gas Side	mm(in)	9.52(3/8)	12.7(1/2)	12.7(1/2)
	Length,std	m(in)	7.5(295)	7.5(295)	7.5(295)
Drain Hose	(O.D. , I.D)	mm(in)	21.5,16.0(0.85,0.63)	21.5,16.0(0.85,0.63)	21.5,16(0.85,0.63)
Dimension (W*H*D)	Indoor	mm	758*260*160	758*260*160	758*260*160
		inch	29.8*10.2*6.3	29.8*10.2*6.3	29.8*10.2*6.3
	Outdoor	mm	770*540*245	770*540*245	770*540*245
		inch	30.3*21.3*9.6	30.3*21.3*9.6	30.3*21.3*9.6
Net Weight	Indoor	kg(lbs)	9(20)	9(20)	13.5(30)
	Outdoor	kg(lbs)	38(83.8)	38(83.8)	60(132.3)

Table-2

Item		Buyer Models		AS-W1224DH0	AS-W1424DH0	AS-W1825DH0
		Unit				
Cooling Capacity	Min.	kcal/h.(W)	980(1,140)	989(1,150)	1,548(1,800)	
		Btu/h.	3,890	-	6,142	
	Type	kcal/h.(W)	3,024(3,517)	3,528(4,102)	4,536(5,274)	
		Btu/h.	12,000	14,000	18,000	
	Max.	kcal/h.(W)	3,474(4,040)	3,732(4,340)	4,987(5,800)	
		Btu/h.	13,800	14,810	19,790	
Heating Capacity	Min.	kcal/h.(W)	757(880)	765(892)	1,204(1,400)	
		Btu/h.	3,003	3039	4,777	
	Type	kcal/h.(W)	3,478(4,043)	3,780(4,396)	5,242(6,096)	
		Btu/h.	13,800	15,000	20,800	
	Max.	kcal/h.(W)	4,007(4,660)	4,119(4,790)	5,761(6,700)	
		Btu/h.	15,900	16,344	22,861	
Power Input	Cooling	W	1,100	1,320	1,600	
	Heating	W	1,120	1,300	1,685	
Running Current	Cooling	A	5.0	5.9	7.0	
	Heating	A	5.1	5.8	8.0	
Starting Current	Cooling	A	5.0	6	7.5	
	Heating	A	5.5	7.1	8.5	
EER	Cooling	kcal/hW	2.75	2.67	2.84	
		Btu/h.W	10.91	10.61	11.25	
	Heating	kcal/hW	3.11	2.91	3.11	
		Btu/h.W	12.32	11.54	12.34	
COP	Cooling	W/W	3.20	3.011	3.30	
	Heating	W/W	3.61	3.38	3.62	
Power Supply		Ø,V,Hz	1,220,60	1, 220, 60	1,220,60	
Power Factor		%	97	97	97	
Air Circulation	Indoor,Max	m³/min(CFM)	8.7(307)	8.7(307)	13.0(459)	
	Outdoor,Max	m³/min(CFM)	26(918)	26(918)	42(1483)	
Moisture Removal		µP/h.(pts/h.)	1.5(3.2)	1.5(3.2)	2.12	
Noise Level (Sound Pressure,1m)	Indoor,High	dB(A)±3	40	40	42	
	Med.	dB(A)±3	37	37	-	
	Low	dB(A)±3	29	29	36	
	Outdoor,Max	dB(A)±3	49	49	55	
Refrigerant(R410A)Charge			845(28.5)	915	1200(40.8)	
Power Cord		AWG#:P*mm²	16:3*1.0	16:3*1.0	12:3*2.5	
Connecting Cable		AWG#:P*mm²	16:4*1.0	16:4*1.0	12:4*2.5	
Connecting Tube (Ø. Socket Flare)	Liquid Side	mm(in)	6.35(1/4)	6.35(1/4)	6.35(1/4)	
	Gas Side	mm(in)	12.7(1/2)	12.7(1/2)	12.7(1/2)	
	Length,std	m(in)	7.5(295)	7.5(295)	7.5(295)	
Drain Hose	(O.D , I.D)	mm(in)	21.5,16.0(0.85,0.63)	21.5,16(0.85,0.63)	21.5,16(0.85,0.63)	
Dimension (W*H*D)	Indoor	mm	758*260*160	758*260*160	1090*300*178	
		inch	29.8*10.2*6.3	29.8*10.2*6.3	42.9*11.8*7.0	
	Outdoor	mm	770*540*245	770*540*245	870*655*320	
		inch	30.3*21.3*9.6	30.3*21.3*9.6	34.3*25.8*12.6	

Exploded View

Indoor Unit

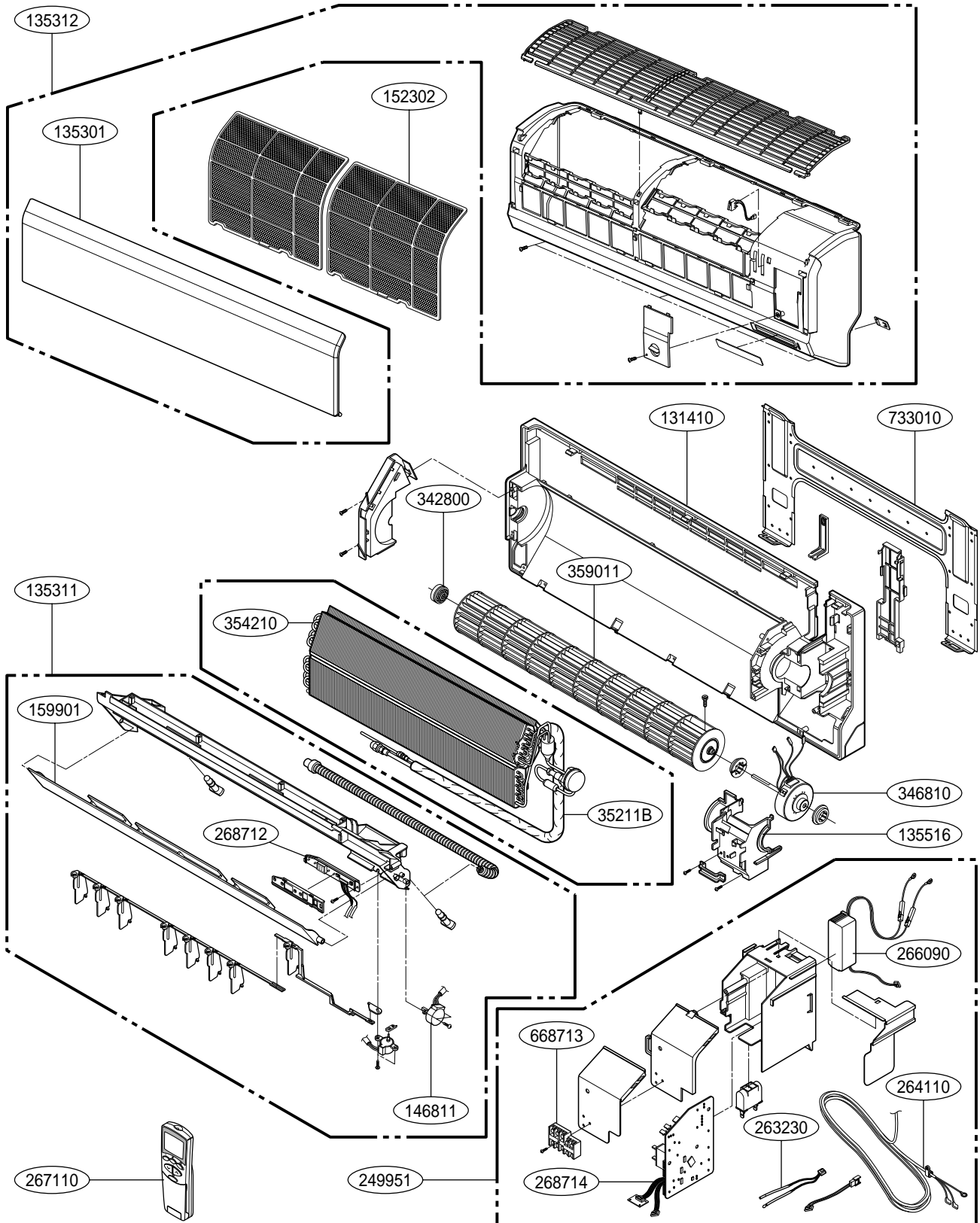

Outdoor Unit

Models: AS-W0964DH0, AS-W1264DH0AS-W0964GH0, AS-W1264GH0, AS-W1224DH0, AS-W1424DH0
(UL Chassis)

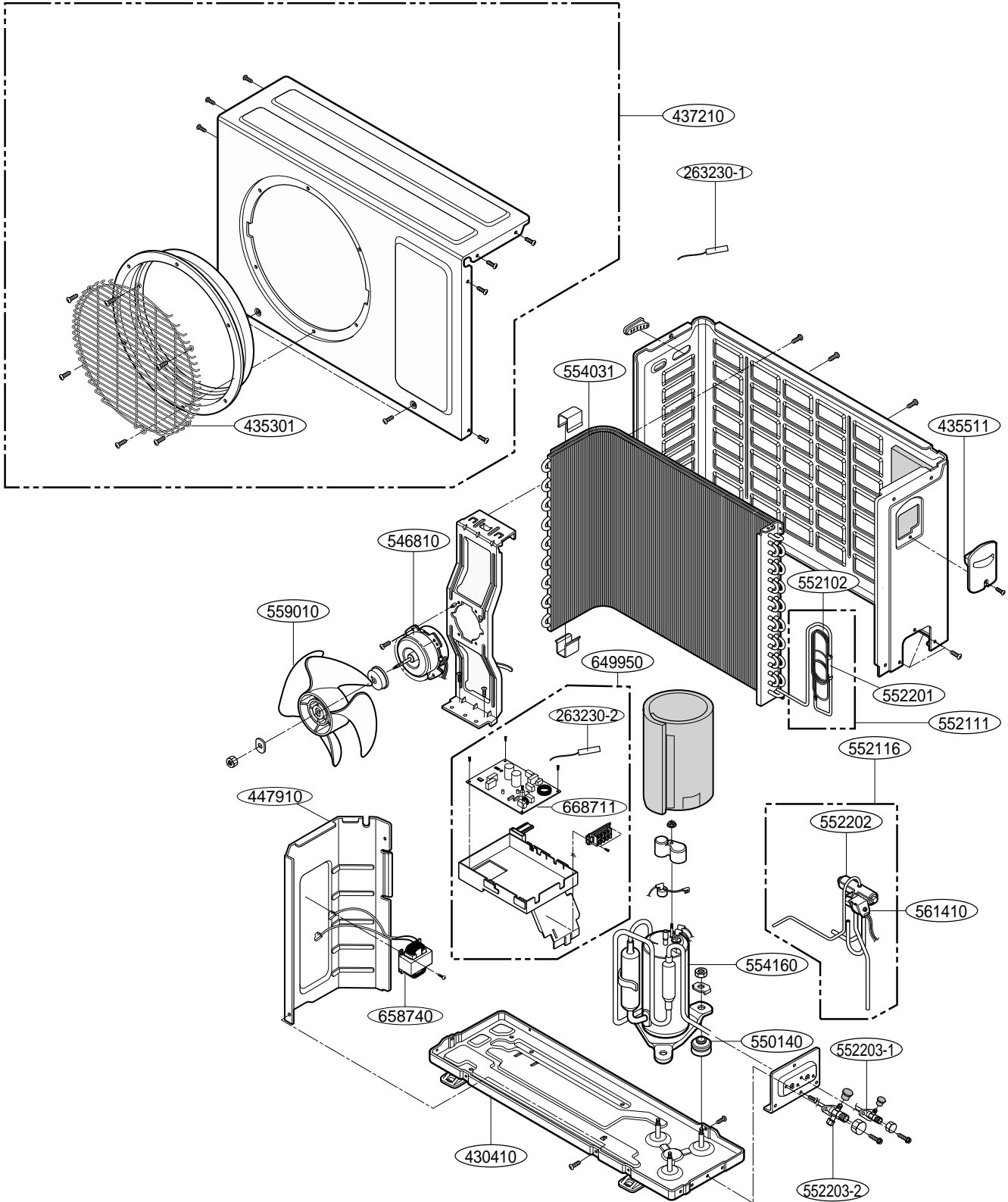

Models: AS-W1865DH0, AS-W1825DH0 (UE Chassis)

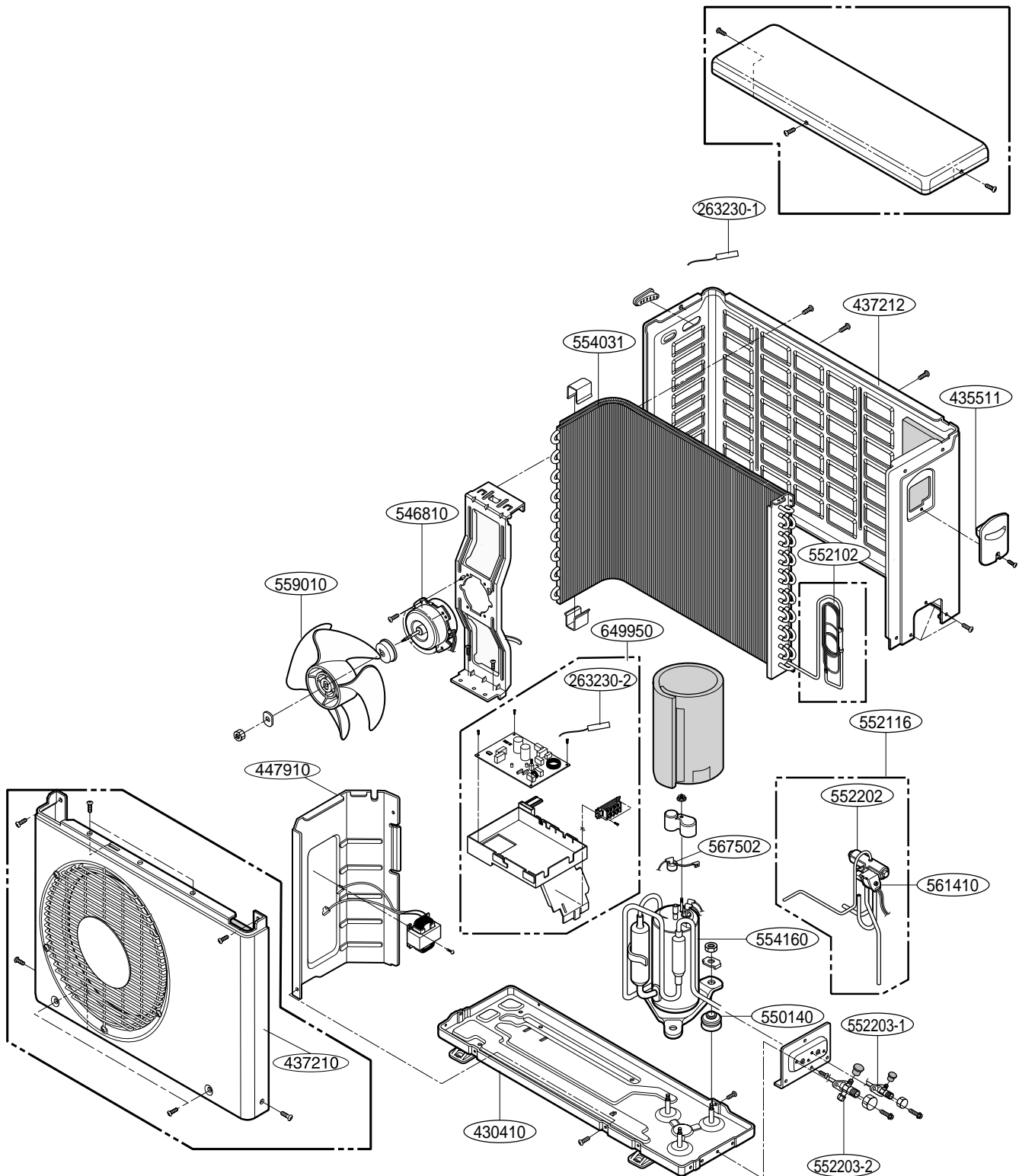

Replacement Parts List

Parts List (Indoor)

LOCATION No.	DESCRIPTION	PART No.			REMARKS
		AS-W0964DH0	AS-W1264DH0	AS-W1865DH0	
131410	CHASSIS ASSEMBLY	3141A20019C	3141A20019C	3141A20020B	
135311	GRILLE ASSEMBLY,DISCHARGE	3531A10307A	3531A10307A	3531A20252A	
135312	GRILLE ASSEMBLY,FRONT	3531A14002D	3531A14002B	3531A20253K	
135516	COVER ASSEMBLY,MOTOR	3551A20156A	3551A20156A	3551A20154A	
146811	MOTOR ASSEMBLY,STEP	4681A20055A	4681A20055A	4681A20055A	
152302	FILTER(MECH),A/C	5230A20051A	5230A20051A	5230A20052A	
159901	VANE,HORIZONTAL	5990A20048A	5990A20048A	5990A20049A	
249951	CONTROL BOX ASSEMBLY	4995A20495B	4995A20495A	4995A20495C	
263230	THERMISTOR ASSEMBLY	6323A20004A	6323A20004A	6323A20004A	
264110	POWER CORD ASSEMBLY	6411A20013E	6411A20013E	6411A20014Z	
266090	H.V ASSEMBLY	6609A10003Z	6609A10003Z	-	
267110	REMOTE CONTROLLER	6711A20077Y	6711A20077Y	6711A20077Y	
268712	PWB(PCB) ASSEMBLY,DISPLAY	6871A20574A	6871A20574A	6871A20624A	
268714	PWB(PCB) ASSEMBLY	6871A20675A	6871A20156A	6871A20156B	
342800	BEARING	4280A20004B	4280A20004B	4280A20004A	
346810	MOTOR ASSEMBLY,INDOOR	4681A20151B	4681A20091J	4681A20091J	
354210	EVAPORATOR ASSEMBLY,FIRST	5421A20218A	5421A20218A	5421A20220A	
359011	FAN ASSEMBLY,CROSS FLOW	5901A20017F	5901A20017F	5901AR2441E	
733010	PLATE ASSEMBLY,INSTALL	3301A20011A	3301A20011A	3301A20002A	
35211B	TUBE ASSEMBLY,TUBING	5211A21363A	5211A21363B	5211A21378C	
W0CZZ	CAPACITOR,DRAWING	3H01487K	-	-	

NOTE) *Please ensure GCSC since these parts may be changed depending upon the buyer's request.
(GCSC WEBSITE <http://biz.LGservice.com>)

Parts List (Indoor)

LOCATION No.	DESCRIPTION	PART No.					REMARKS
		AS-W0964GH0	AS-W1264GH0	AS-W1224DH0	AS-W1424DH0	AS-W1825DH0	
131410	CHASSIS ASSEMBLY	3141A20019C	3141A20019C	3141A20019C	3141A20019E	3141A20020B	
135311	GRILLE ASSEMBLY,DISCHARGE(INDOOR)	3531A10307A	3531A10307A	3531A10307J	3531A10307P	3531A20252H	
135312	GRILLE ASSEMBLY,FRONT(INDOOR)	3531A14003C	3531A14003D	3531A14002R	3531A14002R	3531A20253S	
135314	GRILLE ASSEMBLY,INLET	3531A10339B	3531A10339B	3531A10312D	3531A10312D	3531A20254E	
135516	COVER ASSEMBLY,MOTOR	3551A20156B	3551A20156B	3551A20156B	3551A20156B	3551A20154A	
146811	MOTOR ASSEMBLY,STEP	4681A20055A	4681A20055A	4681A20055A	4681A20055A	4681A20055A	
152302	FILTER(MECH),A/C	5230A20051A	5230A20051A	5230A20051A	5230A20051A	-	
159901	VANE,HORIZONTAL	5990A20048A	5990A20048A	5990A20048A	5990A20048A	5990A20049A	
249951	CONTROL BOX ASSEMBLY,INDOOR	4995A20495B	4995A20495A	4995A20495E	4995A20495F	4995A20495D	
263230	THERMISTOR ASSEMBLY	6323A20004A	6323A20004A	6323A20004A	6323A20004A	6323A20004A	
264110	POWER CORD ASSEMBLY	6411A20013E	6411A20013E	6410A20007E	6410A20007E	6410A20007F	
266090	H.V ASSEMBLY	6609A10003Z	6609A10003Z	6609A10003Z	6609A10003Z	6609A10003Z	
267110	REMOTE CONTROLLER ASSEMBLY	6711A20077Y	6711A20077Y	6711A20124A	6711A20124A	6711A20124A	
268712	PWB(PCB) ASSEMBLY,DISPLAY	6871A20574A	6871A20574A	6871A20574A	6871A20574A	6871A20624A	
268714	PWB(PCB) ASSEMBLY,MAIN	6871A20675A	6871A20156A	6871A20156D	6871A20156C	6871A20156B	
342800	BEARING	4280A20004B	4280A20004B	4280A20004B	4280A20004B	4280A20004A	
346810	MOTOR ASSEMBLY,INDOOR	4681A20151B	4681A20091J	4681A20091J	4681A20091J	4681A20091J	
354210	EVAPORATOR ASSEMBLY,FIRST	5421A20218A	5421A20218A	5421A20218A	5421A20218A	5421A20220A	
359011	FAN ASSEMBLY,CROSS FLOW	5901A20017F	5901A20017F	5901A20017F	5901A20017F	5901AR2441E	
733010	PLATE ASSEMBLY,INSTALL	3301A20011A	3301A20011A	3301A20011A	3301A20011A	3301A20002A	
35211B	TUBE ASSEMBLY,TUBING	5211A21363A	5211A21363B	5211A21363B	5211A21363B	5211A21378C	
W0CZZ	CAPACITOR,DRAWING	3H01487K	-	-	-	-	

NOTE) *Please ensure GCSC since these parts may be changed depending upon the buyer's request.
(GCSC WEBSITE <http://biz.LGservice.com>)

Parts List (Outdoor)

LOCATION No.	DESCRIPTION	PART No.			REMARKS
		AS-W0964DH0	AS-W1264DH0	AS-W1865DH0	
263230	THERMISTOR ASSEMBLY	6323A20003G	6323A20003G	-	
430410	BASE ASSEMBLY,OUTDOOR	3041A20066A	3041A20066A	3041A20022Q	
435301	GRILLE,DISCHARGE	3530A20006B	3530A20006B	3530A20007B	
435511	COVER ASSEMBLY,CONTROL	3551A30115G	3551A30115G	3551A30102A	
437210	PANEL ASSEMBLY,FRONT	3721A20027Q	3721A20027Q	3721A20005H	
437212	PANEL ASSEMBLY,REAR	-	-	3720AP0003D	
447910	BARRIER ASSEMBLY,OUTDOOR	4791A30002G	4791A30002G	2H02110G	
546810	MOTOR ASSEMBLY,OUTDOOR	4681A20068G	4681A20122A	4681A20028K	
550140	ISOLATOR,COMP	4984AR4387A	4H00982E	4H00982E	
552102	TUBE,CAPILLARY BEND		5210A21447E	5210A31380D	
552102-1	TUBE,CAPILLARY BEND	5210A21447M	-	-	
552102-2	TUBE,CAPILLARY BEND	5210A33068B	-	-	
552111	TUBE ASSEMBLY,CAPILLARY	5211A21393C	5211A21393B	-	
552116	TUBE ASSEMBLY,REVERSING	5211A10466B	5211A10466C	5211A21140B	
552201	VALVE,CHECK	3H01552F	3H01552F	-	
552202	VALVE,REVERSING	5220AR3228D	5220AR3228D	5220AR3228E	
554031	CONDENSER ASSEMBLY	5403A20019V	5403A20019V	5403A21012B	
554160	COMPRESSOR	5416A90045A	5416A90029A	5416A90024A	
559010	FAN ASSEMBLY,PROPELLER	5901A10033A	5901A10033A	1A00195B	
561410	COIL ASSEMBLY,REVERSING	6141A20010S	6141A20010S	6141A20010H	
649950	CONTROL BOX ASSEMBLY, OUTDOOR	4995A21006H	4995A21006J	4995A20346F	
668711	PWB(PCB) ASSEMBLY, MAIN(OUTDOOR)	6871A10128P	6871A10128Q	6871A20349F	
552203-1	VALVE,SERVICE	5220A20005B	5220A20005B	5220A20006A	
552203-2	VALVE,SERVICE	5220A20001Q	5220A20006F	2H02479F	
W0CZZ	CAPACITOR,DRAWING	-	0CZZA90002N	3H00611R	

NOTE) *Please ensure GCSC since these parts may be changed depending upon the buyer's request.
(GCSC WEBSITE <http://biz.LGservice.com>)

Parts List (Outdoor)

LOCATION No.	DESCRIPTION	PART No.					REMARKS
		AS-W0964GH0	AS-W1264GH0	AS-W1224DH0	AS-W1424DH0	AS-W1825DH0	
263230-1	THERMISTOR ASSEMBLY	6323A20001C	6323A20001C	6323A20001C	6323A20001C	6323A20001B	
263230-2	THERMISTOR ASSEMBLY	6323A20003G	6323A20003G	6323A20003G	6323A20003G	6323A20003C	
430410	BASE ASSEMBLY,OUTDOOR	3041A20066A	3041A20066A	3041A20066A	3041A20066A	3041A20022Q	
435301	GRILLE,DISCHARGE	3530A20006G	3530A20006G	3530A20006G	3530A20006G	3530A20007B	
435511	COVER ASSEMBLY,CONTROL(OUTDOOR)	3551A30115G	3551A30115G	3551A30115G	3551A30115G	3551A30102A	
437210	PANEL ASSEMBLY,FRONT(OUTDOOR)	3721A20027Q	3721A20027Q	3721A20027Q	3721A20027Q	3721A20005H	
437212	PANEL ASSEMBLY,REAR(OUTDOOR)	3721A20026M	3721A20026M	3721A20026M	3721A20026M	3720AP0003D	
447910	BARRIER ASSEMBLY,OUTDOOR	4791A30002G	4791A30002G	4791A30002G	4791A30002G	2H02110G	
546810	MOTOR ASSEMBLY,OUTDOOR	4681A20068G	4681A20122A	4681A20122A	4681A20122A	4681A20028L	
550140	ISOLATOR,COMP	4984AR4387A	4H00982E	4H00982E	4H00982E	4H00982E	
552102-1	TUBE,CAPILLARY BEND	5210A21447M	5210A21447E	5210A21447E	5210A21447E	5210A31380D	
552102-2	TUBE,CAPILLARY BEND	5210A33068B	5210A33068A	5210A33068A	5210A33068A	5210A31380E	
552111	TUBE ASSEMBLY,CAPILLARY	5211A21393C	5211A21393B	5211A21393B	5211A21393E	-	
552116	TUBE ASSEMBLY,REVERSING	5211A10466B	5211A10466C	5211A10466C	5211A10466D	5211A21140B	
552201	VALVE,CHECK	3H01552F	3H01552F	3H01552F	3H01552F	5220A30004A	
552202	VALVE,REVERSING	5220AR3228D	5220AR3228D	5220AR3228D	5220AR3228D	5220AR3228E	
554031	CONDENSER ASSEMBLY,BENT	5403A20019V	5403A20019V	5403A20019V	5403A20019V	5403A21012B	
554160	COMPRESSOR	5416A90045A	5416A90029A	5416A90029A	5416A90029A	5416A90024A	
559010	FAN ASSEMBLY,PROPELLER	5901A10033A	5901A10033A	5901A10033A	5901A10033A	1A00195B	
561410	COIL ASSEMBLY,REVERSING VALVE	6141A20010S	6141A20010S	6141A20010S	6141A20010S	6141A20010H	
649950	CONTROL BOX ASSEMBLY,OUTDOOR	4995A21006H	4995A21006J	4995A21006M	4995A21006N	4995A20346H	
552203-1	VALVE,SERVICE	5220A20005B	5220A20005B	5220A20005B	5220A20005B	5220A20006A	
552203-2	VALVE,SERVICE	5220A20001Q	5220A20006F	5220A20006F	5220A20006F	2H02479F	
668711	PWB(PCB) ASSEMBLY, MAIN	6871A10128P	6871A10128Q	6871A10128U	6871A10128V	3871A20349G	
W0CZZ	CAPACITOR,DRAWING	0CZZA90002M	0CZZA90002N	0CZZA90002N	0CZZA90002N	0CZZA90002N	

NOTE) *Please ensure GCSC since these parts may be changed depending upon the buyer's request.
(GCSC WEBSITE <http://biz.LGservice.com>)

