

GDM-200PS/200PST/200PST9

SERVICE MANUAL

REVISED

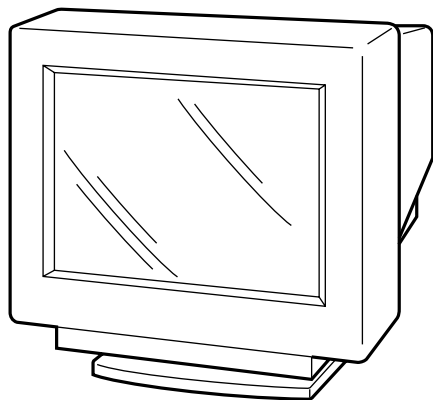

GDM-200PS

US Model

Canadian Model

SH Model

Chassis No. SCC-L11B-A

GDM-200PST

AEP Model

UK Model

GDM-200PST9

AEP Model

Chassis No. SCC-L11C-A

N3 CHASSIS

SPECIFICATIONS

Picture tube	0.25 mm aperture grille pitch 17 inches measured diagonally 90-degree deflection
Viewable image size	Approx. 327 × 243 mm (w/h) (12 ⁷ / ₈ × 9 ⁵ / ₈ inches) 16.0" viewing image
Resolution	Horizontal: Max. 1280 dots Vertical: Max. 1024 lines
Standard image area	Approx. 312 × 234 mm (w/h) (12 ³ / ₈ × 9 ¹ / ₄ inches) or Approx. 293 × 234 mm (w/h) (11 ⁵ / ₈ × 9 ¹ / ₄ inches)
Deflection frequency	Horizontal: 30 to 92 kHz Vertical: 48 to 160 Hz
AC input voltage/current	100 to 240 V, 50 – 60 Hz, 1.7 – 1.0 A
Power consumption	Max. 120 W
Dimensions	406 × 432 × 420 mm (w/h/d) (16 × 17 ¹ / ₈ × 16 ⁵ / ₈ inches)
Mass	Approx. 18.8 kg (41 lb 7 oz)
Supplied accessories	See page 6

Design and specifications are subject to change without notice.

TRINITRON® COLOR GRAPHIC DISPLAY

SONY®



GDM-200PS/200PST/200PST9 SAFETY CHECK-OUT

After correcting the original service problem, perform the following safety checks before releasing the set to the customer:

1. Check the area of your repair for unsoldered or poorly-soldered connections. Check the entire board surface for solder splashes and bridges.
2. Check the interboard wiring to ensure that no wires are "pinched" or contact high-wattage resistors.
3. Check that all control knobs, shields, covers, ground straps, and mounting hardware have been replaced. Be absolutely certain that you have replaced all the insulators.
4. Look for unauthorized replacement parts, particularly transistors, that were installed during a previous repair. Point them out to the customer and recommend their replacement.
5. Look for parts which, though functioning, show obvious signs of deterioration. Point them out to the customer and recommend their replacement.
6. Check the line cords for cracks and abrasion. Recommend the replacement of any such line cord to the customer.
7. Check the B+ and HV to see if they are specified values. Make sure your instruments are accurate; be suspicious of your HV meter if sets always have low HV.
8. Check the antenna terminals, metal trim, "metallized" knobs, screws, and all other exposed metal parts for AC Leakage. Check leakage as described below.

3. Measuring the voltage drop across a resistor by means of a VOM or battery-operated AC voltmeter. The "limit" indication is 0.75 V, so analog meters must have an accurate low-voltage scale. The Simpson 250 and Sanwa SH-63Trd are examples of a passive VOMs that are suitable. Nearly all battery operated digital multimeters that have a 2 V AC range are suitable. (See Fig. A)

WARNING!!

NEVER TURN ON THE POWER IN A CONDITION IN WHICH THE DEGAUSS COIL HAS BEEN REMOVED.

SAFETY-RELATED COMPONENT WARNING!!

COMPONENTS IDENTIFIED BY SHADING AND MARK \triangle ON THE SCHEMATIC DIAGRAMS, EXPLODED VIEWS AND IN THE PARTS LIST ARE CRITICAL FOR SAFE OPERATION. REPLACE THESE COMPONENTS WITH SONY PARTS WHOSE PART NUMBERS APPEAR AS SHOWN IN THIS MANUAL OR IN SUPPLEMENTS PUBLISHED BY SONY. CIRCUIT ADJUSTMENTS THAT ARE CRITICAL FOR SAFE OPERATION ARE IDENTIFIED IN THIS MANUAL. FOLLOW THESE PROCEDURES WHENEVER CRITICAL COMPONENTS ARE REPLACED OR IMPROPER OPERATION IS SUSPECTED.

AVERTISSEMENT!!

NE JAMAIS METTRE SOUS TENSION QUAND LA BOBINE DE DEMAGNETISATION EST ENLEVÉE.

ATTENTION AUX COMPOSANTS RELATIFS À LA SÉCURITÉ!!

LES COMPOSANTS IDENTIFIÉS PAR UNE TRAME ET UNE MARQUE \triangle SONT CRITIQUES POUR LA SÉCURITÉ. NE LES REMPLACER QUE PAR UNE PIÈCE PORTANT LE NUMÉRO SPECIFIÉ. LES RÉGLAGES DE CIRCUIT DONT L'IMPORTANCE EST CRITIQUE POUR LA SÉCURITÉ DU FONCTIONNEMENT SONT IDENTIFIÉS DANS LE PRÉSENT MANUEL. SUIVRE CES PROCÉDURES LORS DE CHAQUE REMPLACEMENT DE COMPOSANTS CRITIQUES, OU LORSQU'UN MAUVAIS FONCTIONNEMENT EST SUSPECTÉ.

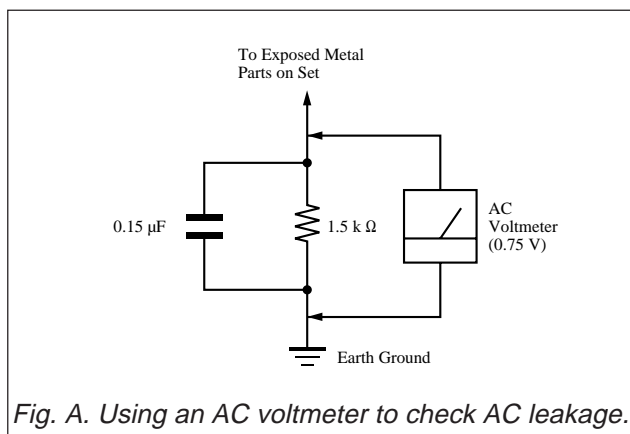

Fig. A. Using an AC voltmeter to check AC leakage.

LEAKAGE TEST

The AC leakage from any exposed metal part to earth ground and from all exposed metal parts to any exposed metal part having a return to chassis, must not exceed 0.5 mA (500 microamperes). Leakage current can be measured by any one of three methods.

1. A commercial leakage tester, such as the Simpson 229 or RCA WT-540A. Follow the manufacturers' instructions to use these instruments.
2. A battery-operated AC milliammeter. The Data Precision 245 digital multimeter is suitable for this job.

CAUTION ON DAS (ECS) CONNECTOR

- The connector for DAS (ECS) adjustment is provided inside the cover shown below. Be careful with an electrical shock when connecting the connector with the power supplied. Also, return the removed cover to the home position.

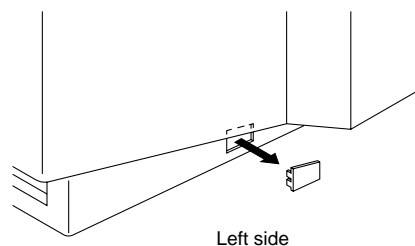

POWER SAVING FUNCTION

This monitor is capable of three states of reduced power consumption. By sensing the absence of video signals and one or both sync signals coming from the host computer, it will reduce power consumption as follows.

Power consumption state	Power consumption	Recovery time	⏻ power indicator
1 Normal operation	≤120 W	–	Green on
2 Standby (1st state)	≤85 W	Approx. 1 sec.	Green and orange alternate
3 Suspend (2nd state)	≤15 W	Approx. 3 sec.	Green and orange alternate
4 Active-off (3rd state)	≤5 W	Approx. 15 sec.	Orange on
5 Power-off	0 W	–	Off

DIAGNOSIS

Failre	Power LED
+B failure	Amber → Off (0.5 sec) (0.5 sec)
Horizontal / Vertical Deflection failure, Thermal protector	Amber → Off (1.5 sec) (0.5 sec)
ABL protector	Amber → Off (0.5 sec) (1.5 sec)
HV failure	Amber → Off → Amber → Off (0.25 sec) (0.5 sec) (0.25 sec) (1.25 sec)
Aging / Self Test	Amber → Off → Green → Off (0.5 sec) (0.5 sec) (0.5 sec) (0.5 sec)

Aging Mode (Video Aging) : During Power Save, press “MENU” key for longer than 2 second.

Self Test (OSD Color Bar) : During Power Save, press “CONTRAST” + (↑) key for longer than 2 second.

Reliability Check Mode : During Power Save, press “CONTRAST”– (↓) key for longer than 2 second.

TIMING SPECIFICATION

MODE AT PRODUCTION	MODE 1	MODE 2
RESOLUTION	1280 X 960	1280 X 1024
CLOCK	148.500 MHz	135.000 MHz
— HORIZONTAL —		
H-FREQ	85.938 kHz	79.976 kHz
	usec	usec
H. TOTAL	11.636	12.504
H. BLK	3.017	3.022
H. FP	0.431	0.119
H. SYNC	1.077	1.067
H. BP	1.508	1.837
H. ACTIV	8.620	9.481
— VERTICAL —		
V. FREQ(Hz)	85.002 Hz	75.025 Hz
	lines	lines
V. TOTAL	1011	1066
V. BLK	51	42
V. FP	1	1
V. SYNC	3	3
V. BP	47	38
V. ACTIV	960	1024
— SYNC —		
INT(G)	NO	NO
EXT(H/V)/POLARITY	YES P/P	YES P/P
EXT(CS)/POLARITY	NO	NO
INT/NON INT	NON INT	NON INT

97.7.14 VER.

TABLE OF CONTENTS

<i>Section</i>	<i>Title</i>	<i>Page</i>
1. GENERAL		1-1
2. DISASSEMBLY		
2-1.	Cabinet Removal	2-1
2-2.	A Board Removal	2-1
2-3.	AC Inlet and I/O Terminal Board Removal	2-2
2-4.	D Board Removal	2-2
2-5.	Service Position	2-2
2-6.	Picture Tube Removal	2-3
3. SAFETY RELATED ADJUSTMENT		3-1
4. ADJUSTMENTS		4-1
5. DIAGRAMS		
5-1.	Block Diagram (with Frame Schematic Diagram)	5-1
5-2.	Circuit Boards Location	5-4
5-3.	Schematic Diagrams and Printed Wiring Boards	5-4
(1)	Schematic Diagram of D Board	5-5
(2)	Schematic Diagram of A Board	5-13
5-4.	Semiconductors	5-16
6. EXPLODED VIEWS		6-1
7. ELECTRICAL PARTS LIST		7-1

SECTION 1 GENERAL

The operating instructions mentioned here are partial abstracts from the Operating Instruction Manual. The page numbers of the Operating Instruction Manual remain as in the manual.

Getting Started

Identifying Parts and Controls

See the pages in parentheses for further details.

Front

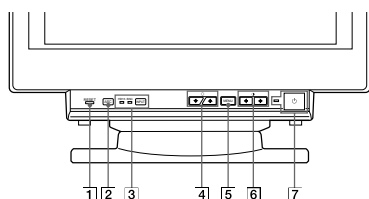

- 1 RESET (reset) button (page 17)**
Resets the adjustments to the factory settings.
- 2 ASC (auto sizing and centering) button (page 7)**
Automatically adjusts the size and centering of the images.
- 3 INPUT (input) button and HD15/BNC indicators (page 8)**
Selects the HD15 or 5BNC video input signal. Each time you press this button, the input signal and corresponding indicator alternate.
- 4 (brightness) (↓/↑) buttons (pages 8 – 17)**
Adjust the picture brightness.
Function as the (←/→) buttons when adjusting other items.
- 5 MENU (menu) button (pages 8, 10 -17)**
Displays the MENU OSD.
- 6 (contrast) (←/→) buttons (pages 8 – 17)**
Adjust the contrast.
Function as the (←/→) buttons when adjusting other items.
- 7 (power) switch and indicator (pages 19, 22)**
Turns the monitor on or off.
The indicator lights up in green when the monitor is turned on, and lights up in orange when the monitor is in power saving mode.

Rear

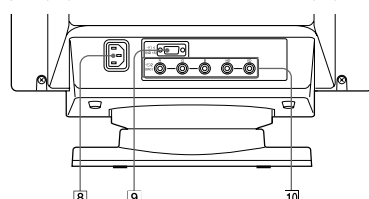

- 8 AC IN connector**
Provides AC power to the monitor.
- 9 Video input 1 connector (HD15)**
Inputs RGB video signals (0.714 Vp-p, positive) and SYNC signals.



Pin No.	Signal	Pin No.	Signal
1	Red	8	Blue Ground
2	Green (Composite Sync on Green)	9	DDC + 5V*
		10	Ground
		11	Ground
3	Blue	12	Bi-Directional Data (SDA)*
4	Ground	13	H. Sync
5	DDC Ground*	14	V. Sync
6	Red Ground	15	Data Clock(SCL)*
7	Green Ground		

* Display Data Channel (DDC) Standard of VESA

- 10 Video input 2 connector (5 BNC)**
Inputs RGB video signals (0.714 Vp-p, positive) and SYNC signals.

Customizing Your Monitor

Before adjusting

- Connect the monitor and the computer, and turn them on.
- Select "LANG" in the MENU OSD, then select "ENGLISH" (English) (see page 17).

Adjusting the Picture Brightness

Once the setting is adjusted, it will be stored in memory for all input signals received.

- 1 Press the (brightness) ↓/↑ buttons.**
The BRIGHTNESS/CONTRAST OSD appears.

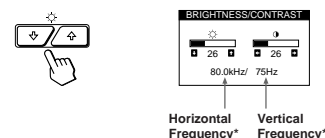

- 2 Press the (brightness) ↓/↑ buttons again to adjust the picture brightness.**

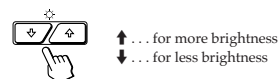

The OSD automatically disappears after about 3 seconds.

To reset, press the RESET button while the OSD is on. The brightness and contrast are both reset to the factory settings.

* The horizontal and vertical frequencies for the received input signal appear in the BRIGHTNESS/CONTRAST OSD.

Adjusting the Picture Contrast

Once the setting is adjusted, it will be stored in memory for all input signals received.

- 1 Press the (contrast) ←/→ buttons.**
The BRIGHTNESS/CONTRAST OSD appears.

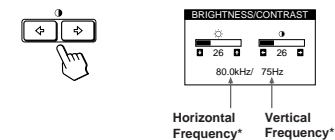

- 2 Press the (contrast) ←/→ buttons again to adjust the picture contrast.**

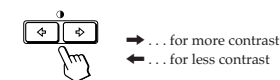

The OSD automatically disappears after about 3 seconds.

To reset, press the RESET button while the OSD is on. The brightness and contrast are both reset to the factory settings.

* The horizontal and vertical frequencies for the received input signal appear in the BRIGHTNESS/CONTRAST OSD.

Introducing the On-screen Display System

Most adjustments are made using the MENU OSD.

MENU OSD

Press the MENU button to display the MENU OSD.

This MENU OSD contains links to the other OSDs described below.

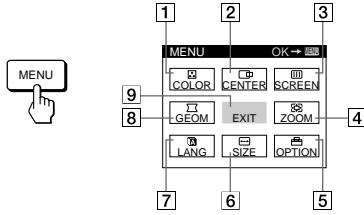

- 1 **COLOR**
Displays the COLOR OSD for adjusting the color temperature.
- 2 **CENTER**
Displays the CENTER OSD for adjusting the centering of the picture.
- 3 **SCREEN**
Displays the SCREEN OSD for adjusting the vertical and horizontal convergence, etc.
- 4 **ZOOM**
Displays the ZOOM OSD for enlarging and reducing the picture.
- 5 **OPTION**
Displays the OPTION OSD for adjusting the OSD position and degaussing the screen, etc.
- 6 **SIZE**
Displays the SIZE OSD for adjusting the picture size.
- 7 **LANG**
Displays the LANGUAGE OSD for selecting the language.
- 8 **GEOM**
Displays the GEOMETRY OSD for adjusting the picture rotation and pincushion, etc.
- 9 **EXIT**
Closes the MENU OSD.

Navigating the MENU on-screen display

Select a link using the \uparrow/\downarrow and \leftarrow/\rightarrow buttons in the MENU OSD.

- 1 **Press the MENU button.**
The MENU OSD appears.



- 2 **Press the \uparrow/\downarrow and \leftarrow/\rightarrow buttons to select a link.**
The selected link turns yellow.



- 3 **Press the MENU button.**
The selected OSD appears.



If no buttons are pressed, the MENU OSD automatically disappears after about 10 seconds.
To close the MENU OSD, select "EXIT" and press the MENU button.

Adjusting the on-screen display settings

Select an item using the \uparrow/\downarrow buttons and adjust or select the setting of that item using the \leftarrow/\rightarrow buttons.

To select an item, press the \uparrow/\downarrow button.
The \blacktriangleright mark goes to the selected item and the item turns yellow.



To adjust or set an item, press the \leftarrow/\rightarrow button.
When adjusting an item, the bar length and the figure increase or decrease.
When setting an item, the \blacksquare mark turns green.



Using the CENTER On-screen Display

The CENTER settings allow you to adjust the centering of the picture.
Once the setting is adjusted, it will be stored in memory for the current input signal.

- 1 **Press the MENU button.**
The MENU OSD appears.



- 2 **Press the \uparrow/\downarrow and \leftarrow/\rightarrow buttons to select "CENTER," and press the MENU button again.**
The CENTER OSD appears.

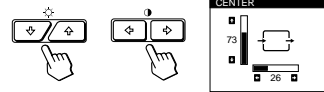

- 3 **For horizontal adjustment**
Press the \leftarrow/\rightarrow buttons.

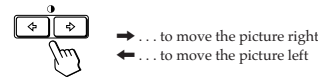

- For vertical adjustment**
Press the \uparrow/\downarrow buttons.

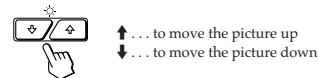

The OSD automatically disappears after about 30 seconds.
To close the OSD, press the MENU button again.

To reset, press the RESET button while the OSD is on.
The horizontal and vertical centerings are both reset to the factory settings.

Using the SIZE On-screen Display

The SIZE settings allow you to adjust the size of the picture.
Once the setting is adjusted, it will be stored in memory for the current input signal.

- 1 **Press the MENU button.**
The MENU OSD appears.



- 2 **Press the \uparrow/\downarrow and \leftarrow/\rightarrow buttons to select "SIZE," and press the MENU button again.**
The SIZE OSD appears.

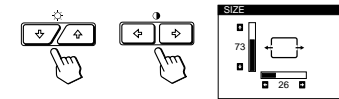

- 3 **For horizontal adjustment**
Press the \leftarrow/\rightarrow buttons.

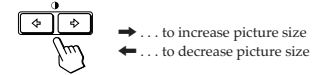

- For vertical adjustment**
Press the \uparrow/\downarrow buttons.

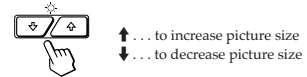

The OSD automatically disappears after about 30 seconds.
To close the OSD, press the MENU button again.

To reset, press the RESET button while the OSD is on.
The horizontal and vertical sizes are both reset to the factory settings.

Using the GEOM (Geometry) On-screen Display

The GEOM (geometry) settings allow you to adjust the shape and orientation of the picture. Once the rotation is adjusted, it will be stored in memory for all input signals received. All other adjustments will be stored in memory for the current input signal.

- 1 Press the **MENU** button. The MENU OSD appears.



- 2 Press the **☼/↑/↓** and **◀/▶** buttons to select "GEOM," and press the **MENU** button again. The GEOMETRY OSD appears.

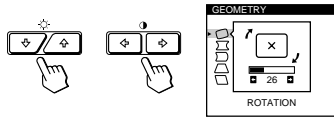

- 3 Press the **☼/↑/↓** buttons to select the item you want to adjust.



Select	To
☼ ROTATION	adjust the picture rotation
☼ PINCUSHION	adjust the picture sides
☼ PIN BALANCE	adjust the picture side balance
☼ KEystone	adjust the picture width
☼ KEY BALANCE	adjust the picture shape balance

- 4 Press the **◀/▶** buttons to adjust the settings.



For	Press
☼ ROTATION	<ul style="list-style-type: none"> → ... to rotate the picture clockwise ← ... to rotate the picture counterclockwise
☼ PINCUSHION	<ul style="list-style-type: none"> → ... to expand the picture sides ← ... to contract the picture sides
☼ PIN BALANCE	<ul style="list-style-type: none"> → ... to move the picture sides to the right ← ... to move the picture sides to the left
☼ KEystone	<ul style="list-style-type: none"> → ... to increase the picture width at the top ← ... to decrease the picture width at the top
☼ KEY BALANCE	<ul style="list-style-type: none"> → ... to move the top of the picture to the right ← ... to move the top of the picture to the left

The OSD automatically disappears after about 30 seconds. To close the OSD, press the **MENU** button again.

To reset, press the **RESET** button while the OSD is on. The selected item is reset to the factory setting.

Using the ZOOM On-screen Display

The ZOOM settings allow you to enlarge or reduce the picture. Once the setting is adjusted, it will be stored in memory for the current input signal.

- 1 Press the **MENU** button. The MENU OSD appears.



- 2 Press the **☼/↑/↓** and **◀/▶** buttons to select "ZOOM," and press the **MENU** button again. The ZOOM OSD appears.

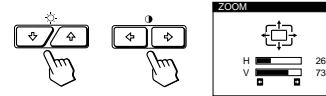

- 3 Press the **◀/▶** buttons to adjust the picture zoom.

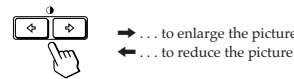

The OSD automatically disappears after about 30 seconds. To close the OSD, press the **MENU** button again.

To reset, press the **RESET** button while the OSD is on.

Note

The picture zoom adjustment will stop as soon as either the horizontal or vertical size reaches its maximum or minimum value.

Using the COLOR On-screen Display

You can change the monitor's color temperature. For example, you can change the colors of a picture on the screen to match the actual colors of the printed picture. Once the setting is adjusted, it will be stored in memory for all input signals received.

- 1 Press the **MENU** button. The MENU OSD appears.



- 2 Press the **☼/↑/↓** and **◀/▶** buttons to select "COLOR," and press the **MENU** button again. The COLOR OSD appears.

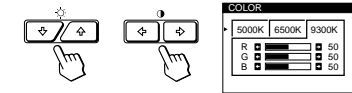

- 3 Press the **◀/▶** buttons to select the color temperature.



There are three color temperature modes in the OSD. The preset adjustments are: 5000K, 6500K, 9300K

Fine tune the color temperature

Press the **☼/↑/↓** buttons to select R (red), G (green), or B (blue) and adjust by pressing the **◀/▶** buttons.

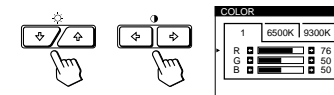

The "5000K," "6500K" or "9300K" disappears and the new color settings are memorized for each of the three color modes.

The color temperature modes change as follows: 5000K → 1, 6500K → 2, 9300K → 3

The OSD automatically disappears after about 30 seconds. To close the OSD, press the **MENU** button again.

To reset, press the **RESET** button while the OSD is on. The selected color temperature is reset to the factory settings.

Using the SCREEN On-screen Display

Adjust convergence settings to eliminate red or blue shadows that may appear around objects on the screen. Adjust the CANCEL MOIRE function to eliminate wavy or elliptical lines that may appear on the screen. Once CANCEL MOIRE is adjusted, it will be stored in memory for the current input signal. All other adjustments will be stored in memory for all input signals received.

- Press the **MENU** button.
The MENU OSD appears.



- Press the **UP**, **DOWN**, **LEFT**, and **RIGHT** buttons to select "**SCREEN**," and press the **MENU** button again.
The SCREEN OSD appears.

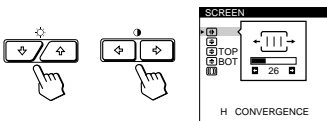

- Press the **UP**, **DOWN**, **LEFT**, and **RIGHT** buttons to select the item you want to adjust.



Select	To
H H CONVERGENCE	adjust the horizontal convergence
V V CONVERGENCE	adjust the vertical convergence
TOP V CONVER TOP	adjust the screen's upper vertical convergence
BOT V CONVER BOTTOM	adjust the screen's lower vertical convergence
MO CANCEL MOIRE	eliminate elliptical or wavy lines on the screen
ADJ * MOIRE ADJUST	adjust the degree of moire cancellation

* CANCEL MOIRE must be "ON" for "ADJ (MOIRE ADJUST)" to appear on the screen.

- Press the **LEFT** and **RIGHT** buttons to adjust the settings.



For	Press
H H CONVERGENCE	<ul style="list-style-type: none"> → ... to shift red shadows to the right and blue shadows to the left ← ... to shift red shadows to the left and blue shadows to the right
V V CONVERGENCE	<ul style="list-style-type: none"> → ... to shift red shadows up and blue shadows down ← ... to shift red shadows down and blue shadows up
TOP V CONVER TOP	<ul style="list-style-type: none"> → ... to shift red shadows up and blue shadows down ← ... to shift red shadows down and blue shadows up
BOT V CONVER BOTTOM	<ul style="list-style-type: none"> → ... to shift red shadows up and blue shadows down ← ... to shift red shadows down and blue shadows up
MO CANCEL MOIRE	<ul style="list-style-type: none"> → ... to turn CANCEL MOIRE "ON" ← ... to turn CANCEL MOIRE "OFF"
ADJ MOIRE ADJUST	<ul style="list-style-type: none"> → ... to increase the moire cancellation effect ← ... to decrease the moire cancellation effect

The OSD automatically disappears after about 30 seconds. To close the OSD, press the MENU button again.

To reset, press the RESET button while the OSD is on. The selected item is reset to the factory setting.

Using the OPTION On-screen Display

The OPTION OSD allows you to manually degauss the screen and adjust settings such as the OSD position and power saving delay time. It also allows you to lock the controls.

Degaussing the screen

The monitor screen is automatically degaussed (demagnetized) when the power is turned on. You can also manually degauss the monitor.

- Press the **MENU** button.
The MENU OSD appears.



- Press the **UP**, **DOWN**, **LEFT**, and **RIGHT** buttons to select "**OPTION**," and press the **MENU** button again.
The OPTION OSD appears.

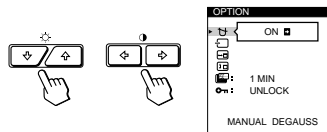

- Press the **UP**, **DOWN**, **LEFT**, and **RIGHT** buttons to select "**MANUAL DEGAUSS**."



- Press the **ENTER** button.
The screen is degaussed for about 2 seconds.



If you need to degauss the screen a second time, wait for at least 20 minutes before repeating the steps above.

The OPTION OSD automatically disappears after about 30 seconds. To close the OSD, press the MENU button again.

Changing the on-screen display position

You can change the OSD position (for example, when you want to adjust the picture behind the OSD).

- Press the **MENU** button.
The MENU OSD appears.



- Press the **UP**, **DOWN**, **LEFT**, and **RIGHT** buttons to select "**OPTION**," and press the **MENU** button again.
The OPTION OSD appears.

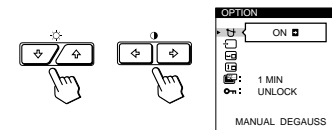

- Press the **UP**, **DOWN**, **LEFT**, and **RIGHT** buttons to select "**OSD H POSITION**" or "**OSD V POSITION**."
Select "**OSD H POSITION**" to adjust the horizontal position.

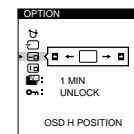

Select "**OSD V POSITION**" to adjust the vertical position.

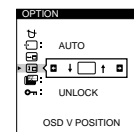

- Press the **LEFT** and **RIGHT** buttons to move the OSD to the desired position.



The OPTION OSD automatically disappears after about 30 seconds. To close the OSD, press the MENU button again.

To reset, press the RESET button while the OSD is on.

Setting the power saving delay time

You can set the delay time before the monitor enters the power saving mode. See page 19 for more information on this monitor's power saving capabilities.

- 1 Press the MENU button.
The MENU OSD appears.



- 2 Press the and buttons to select "OPTION," and press the MENU button again.
The OPTION OSD appears.

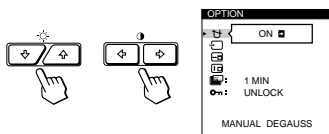

- 3 Press the buttons to select "PWR SAVE DELAY."

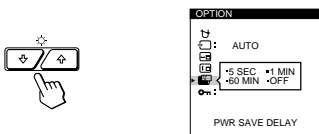

- 4 Press the buttons to select the desired time.



When PWR SAVE DELAY is set to "OFF," the monitor does not go into power saving mode.

The OPTION OSD automatically disappears after about 30 seconds.
To close the OSD, press the MENU button again.

To reset, press the RESET button while the OSD is on.

Locking the controls

The control lock function disables all of the buttons on the front panel except the (power) switch, MENU and INPUT buttons.

- 1 Press the MENU button.
The MENU OSD appears.



- 2 Press the and buttons to select "OPTION," and press the MENU button again.
The OPTION OSD appears.

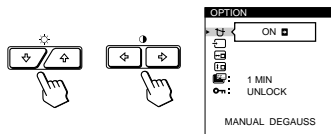

- 3 Press the buttons to select "CONTROL LOCK."

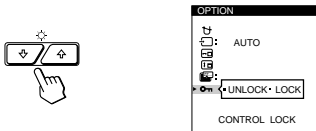

- 4 Press the buttons to select "LOCK."



The OPTION OSD automatically disappears after about 30 seconds.
To close the OSD, press the MENU button again.

Once you select "LOCK," you cannot select any items except "EXIT" and "OPTION" in the MENU OSD. If you press any button other than the (power) switch, MENU and INPUT buttons, the mark appears on the screen.

To cancel the control lock

Repeat steps 1 through 3 above and press the buttons to select "UNLOCK."

Using the LANG (Language) On-screen Display

English, French, German, Spanish and Japanese versions of the OSDs are available.

- 1 Press the MENU button.
The MENU OSD appears.



- 2 Press the and buttons to select "LANG," and press the MENU button again.
The LANGUAGE OSD appears.

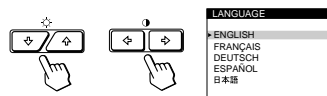

- 3 Press the buttons to select the desired language.



ENGLISH: English, FRANÇAIS: French, DEUTSCH: German, ESPAÑOL: Spanish, or 日本語: Japanese.

The OSD automatically disappears after about 30 seconds.
To close the OSD, press the MENU button again.

To reset to English, press the RESET button while the OSD is on.

Resetting the Adjustments

Resetting an adjustment item

- 1 Press the MENU, and buttons to select the OSD containing the item you want to reset.

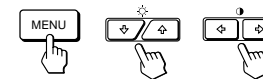

- 2 Press the buttons to select the item you want to reset.



- 3 Press the RESET button.



Resetting all of the adjustment data for the current input signal

When there is no OSD displayed, press the RESET button.

All of the adjustments data for the current input signal is reset to the factory settings.

Note that adjustment data not affected by changes in input signal (OSD language, OSD position, input signal selection, power saving delay time and the control lock function) is not reset to the factory settings.



Resetting all of the adjustment data for all input signals

Press and hold the RESET button for more than two seconds.

All of the adjustment data, including the brightness and contrast, is reset to the factory settings.



Warning Messages

If there is something wrong with the input signal, one of the following messages appears.
The message disappears after about 30 seconds.

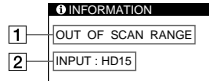

1 The input signal condition

“OUT OF SCAN RANGE” indicates that the input signal is not supported by the monitor’s specifications.

“NO INPUT SIGNAL” indicates that no signal is input, or the input signal from the selected input connector is not received.

2 The selected input connector

Indicates which input connector is receiving the wrong signal. If there is something wrong with the signal from both input connectors, “HD15” and “BNC” are displayed alternately.

To solve these problems, see “Troubleshooting” below.

Troubleshooting

This section may help you isolate the cause of a problem and as a result, eliminate the need to contact technical support.

Symptom	Check these items
No picture	
If the \odot indicator is not lit	<ul style="list-style-type: none"> Check that the power cord is properly connected. Check that the \odot (power) switch is in the “on” position.
If the “NO INPUT SIGNAL” message appears on the screen, or if the \odot indicator is either orange or alternating between green and orange	<ul style="list-style-type: none"> Try pressing any key on the computer keyboard. Check that your computer power switch is in the “on” position. Check that the input select setting is correct. Check that the video signal cable is properly connected and all plugs are firmly seated in their sockets. Check that the 5 BNCs are connected in the correct order (from left to right: Red–Green–Blue–HD–VD) (page 6). Ensure that no pins are bent or pushed in the HD15 video input connector. Check that the video board is completely seated in the proper bus slot.
If the “OUT OF SCAN RANGE” message appears on the screen	<ul style="list-style-type: none"> Check that the video frequency range is within that specified for the monitor. (Horizontal: 30 – 92 kHz, Vertical: 48 – 160 Hz) Refer to your computer’s instruction manual to adjust the video frequency range. If you are using a video signal cable adapter, check that it is correct.
If no message is displayed and the \odot indicator is green or flashing orange	<ul style="list-style-type: none"> See “Self-diagnosis Function” (page 22).
If using a Macintosh system	<ul style="list-style-type: none"> Check that the Macintosh adapter and the video signal cable are properly connected (page 6).
If using Windows® 95	<ul style="list-style-type: none"> If you cannot find “GDM-200PS” among the Sony monitors in the Windows 95 monitor selection screen, select the DDC standard monitor or install the Windows 95 Monitor Information Disk (page 7). The DDC standard does not apply to the 5 BNC connectors. If you use the DDC standard, connect the computer to the HD15 connector with the supplied video signal cable.
Picture is scrambled	<ul style="list-style-type: none"> Check your graphics board manual for the proper monitor setting. Check this manual and confirm that the graphics mode and the frequency you are trying to operate at is supported. Even if the frequency is within the proper range, some video boards may have a sync pulse that is too narrow for the monitor to sync correctly.

Symptom	Check these items
Color is not uniform	<ul style="list-style-type: none"> Degauss the monitor (page 15). If you place equipment which generates a magnetic field, such as a loudspeaker, near the monitor, or you change the direction of the monitor, color may lose uniformity. The degauss function demagnetizes the metal frame of the CRT to obtain a neutral field for uniform color reproduction. If a second degauss cycle is needed, allow a minimum interval of 20 minutes for the best result.
You cannot adjust the monitor with the buttons on the front panel	<ul style="list-style-type: none"> If the control lock function is set to on, set it to off using the OPTION OSD (page 16).
White does not look white	<ul style="list-style-type: none"> Adjust the color temperature (page 13). Check that the 5 BNCs are connected in the correct order (from left to right: Red–Green–Blue–HD–VD) (page 6).
Screen image is not centered or sized properly	<ul style="list-style-type: none"> Adjust the size or centering (page 11). Some video modes do not fill the screen to the edges. This problem tends to occur with certain video boards.
Edges of the image are curved	<ul style="list-style-type: none"> Adjust the geometry (page 12).
White lines show red or blue shadows at edges	<ul style="list-style-type: none"> Adjust the convergence (page 14).
Picture is fuzzy	<ul style="list-style-type: none"> Adjust the contrast and brightness (page 9). Degauss the monitor (page 15). If you place equipment which generates a magnetic field, such as a loudspeaker, near the monitor, or you change the direction of the monitor, color may lose uniformity. The degauss function demagnetizes the metal frame of the CRT to obtain a neutral field for uniform color reproduction. If a second degauss cycle is needed, allow a minimum interval of 20 minutes for the best result. If red or blue shadows appear along the edges of images, adjust the convergence (page 14). If the moire is cancelled, the picture may become fuzzy. Decrease the moire cancellation effect (page 14).
Picture bounces or has wavy oscillations	<ul style="list-style-type: none"> Isolate and eliminate any potential sources of electric or magnetic fields. Common causes for this symptom are electric fans, fluorescent lighting or laser printers. If you have another monitor close to this monitor, increase the distance between them to reduce the interference. Try plugging the monitor into a different AC outlet, preferably on a different circuit. Try the monitor on a different computer in a different room.
Picture is flickering	<ul style="list-style-type: none"> Set the refresh rate on the computer to obtain the best possible picture by referring to your computer’s manual.
Picture appears to be ghosting	<ul style="list-style-type: none"> Eliminate the use of video cable extensions and/or video switch boxes if this symptom occurs. Excessive cable length or a weak connection can produce this symptom.
Wavy or elliptical (moire) pattern is visible	<ul style="list-style-type: none"> Cancel the moire (page 14). The moire may be modified depending on the connected computer. Due to the relationship between resolution, monitor dot pitch and the pitch of some image patterns, certain screen backgrounds sometimes show moire. Change your desktop pattern.
Two fine horizontal lines (wires) are visible	<ul style="list-style-type: none"> These wires stabilize the vertically striped aperture grille (page 19). This aperture grille allows more light to pass through to the screen giving the Trinitron CRT more color and brightness.
Hum is heard right after the power is turned on	<ul style="list-style-type: none"> When the power is turned on, the auto-degauss cycle is activated. While the auto-degauss cycle is activated, a hum may be heard. The same hum is heard when the monitor is manually degaussed. This is not a malfunction.

SECTION 2 DISASSEMBLY

GDM-200PS/200PST/200PST9

2-1. CABINET REMOVAL

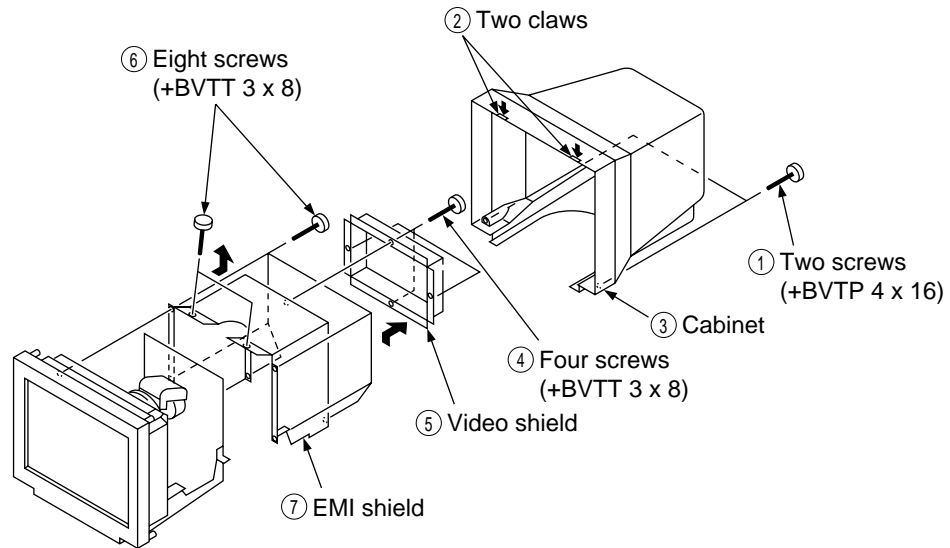

2-2. A BOARD REMOVAL

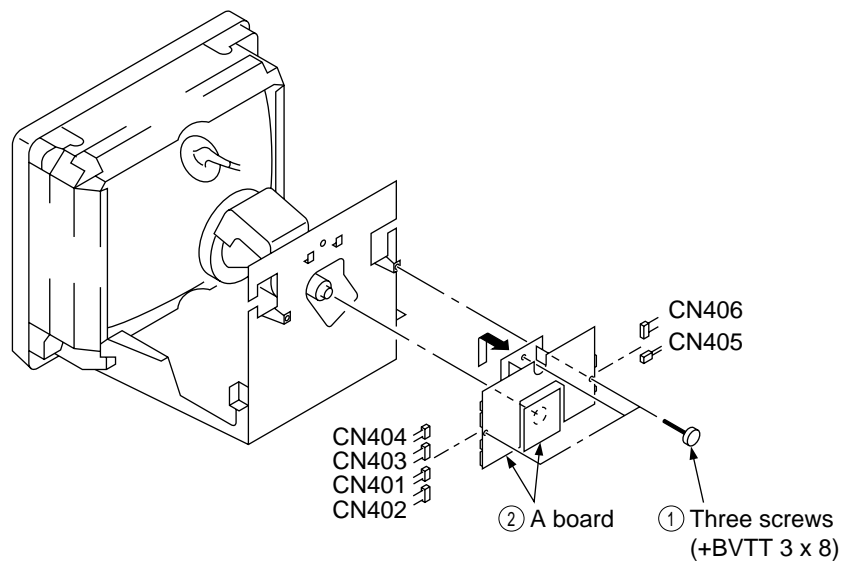

2-3. AC INLET AND I/O TERMINAL BOARD REMOVAL

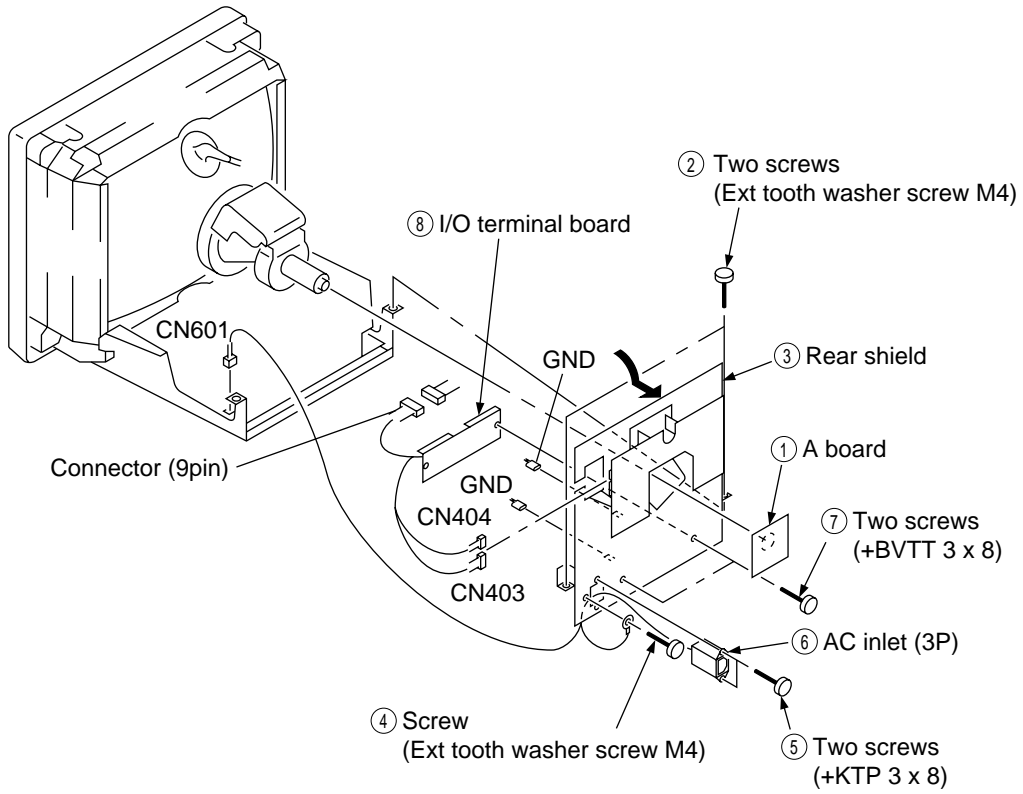

2-4. D BOARD REMOVAL

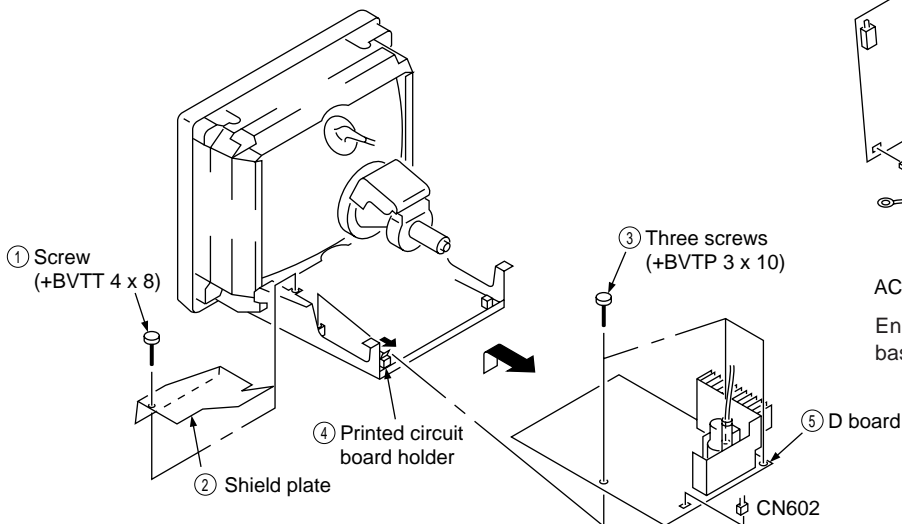

2-5. SERVICE POSITION

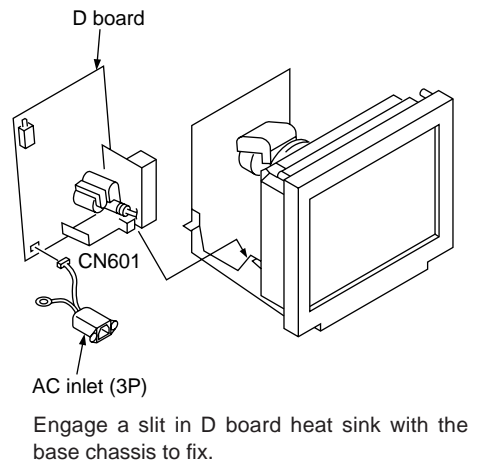

2-6. PICTURE TUBE REMOVAL

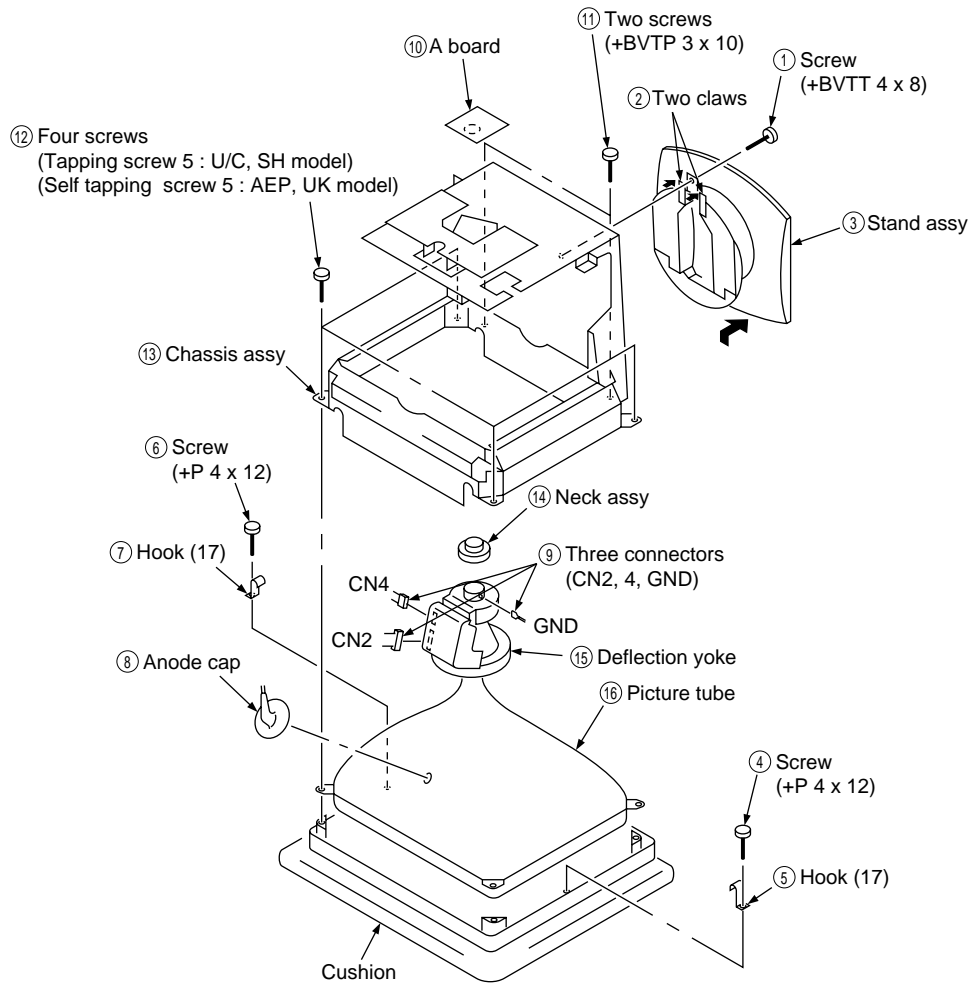

• REMOVAL OF ANODE-CAP

NOTE: Short circuit the anode of the picture tube and the anode cap to the metal chassis, CRT shield or carbon painted on the CRT, after removing the anode.

• REMOVING PROCEDURES

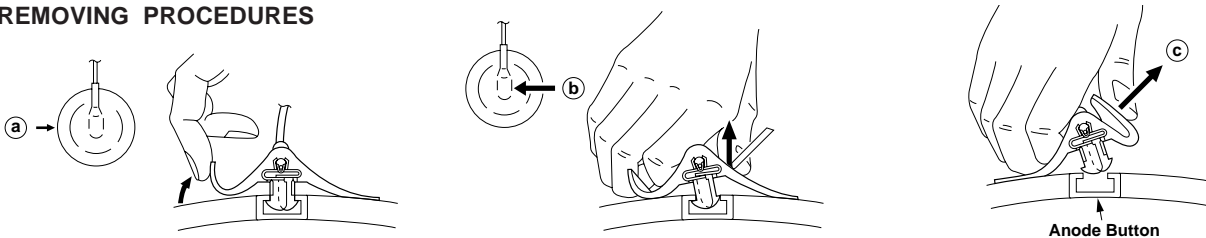

- ① Turn up one side of the rubber cap in the direction indicated by the arrow ①.
- ② Using a thumb pull up the rubber cap firmly in the direction indicated by the arrow ②.
- ③ When one side of the rubber cap is separated from the anode button, the anode-cap can be removed by turning up the rubber cap and pulling up it in the direction of the arrow ③.

• HOW TO HANDLE AN ANODE-CAP

- ① Don't hurt the surface of anode-caps with sharp shaped material!
- ② Don't press the rubber hardly not to hurt inside of anode-caps! A material fitting called as shatter-hook terminal is built in the rubber.
- ③ Don't turn the foot of rubber over hardly! The shatter-hook terminal will stick out or hurt the rubber.

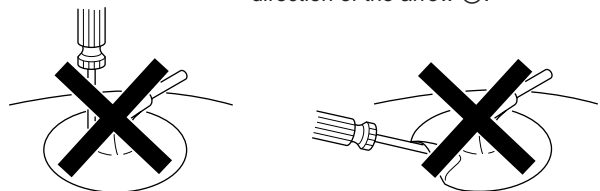

SAFETY RELATED ADJUSTMENT

When replacing or repairing the shown below table, the following operational checks must be performed as a safety precaution against X-rays emissions from the unit.

	Part Replaced (☒)
HV ADJ	RV901

	Part Replaced (☒)
HV Regulator Circuit	D board IC901, R903, R922, T901 • Mounted D board
HV HOLD DOWN Circuit	D board D913, D916, C923, R920, R927, T901 • Mounted D board
Beam Current Protector Circuit	D board IC901, D902, D918, D919, R923, R928, R932, R933, R934, R942, R944, R945, R947, R948, R951, T901 • Mounted D board

* Confirm one minute later turning on the power.

• HV Protector Circuit Check

- (1) Confirm that the voltage between cathode of D913 and GND is more than 17.5 V DC.
- (2) Using external DC Power Supply, apply the voltage shown below between cathode of D913 and GND, and confirm that the HV HOLD DOWN circuite works. (TV Rester disappears)
Standard voltage: Less than 23.40 V DC

• Beam Current Protector Circuite Check

(1) Hardware logic circuit

- Turn the POWER SW on, and check that the RASTER fades in.
- Connect a variable resistor (20 k Ω or more) and an ammeter in series between FBT pin ⑪ and – 15 V line (– side of C637). Decrease gradually the resistance of the variable resistor from maximum to minimum, and confirm that the Beam Current Protector Circuite works (TV Rester disappears). The current must be within the range shown below.

Standard current: Less than 1.09 mA

(2) Software logic circuit

- Turn the POWER SW on, and check that the RASTER fades in.
- Short between + of C639 and GND.
- Connect a variable resistor (20 k Ω or more) and an ammeter in series between FBT pin ⑪ and – 15 V line (– side of C637). Decrease gradually the resistance of the variable resistor form maximum to minimum, and confirm that the Beam Current Protector Circuite works (TV Raster disappears). The current must be within the range shown below.

Standard current: Less than 1.14 mA

SECTION 4 ADJUSTMENTS

GDM-200PS/200PST/200PST9

• Landing Rough Adjustment

1. Enter the full white signal. (or the full black dots signal).
 2. Adjust the contrast to the maximum.
 3. Make the screen monogreen.
- Note: Off the outputs from R ch and B ch of SG.
4. Reverse the DY, and adjust coarsely the purity magnet so that a green raster positions in the center of screen.
 5. Adjust the tilt of DY, and fix lightly with a clamp.
- Note: "TILT" = 128

• Landing Fine Adjustment

1. Put the set inside the Helmholtz coil.
2. Input the single green signal and set the CONT control to MAX.

<Landing adjustment luminance>

Landing adjustment after 2 hours of aging by Landing adjustment luminance.

• Landing adjustment luminance

: 1/2 of Landing between COOL and HOT
(Reference: IK = 200 μ A)

• Max luminance

: 120 cg/m² IK = 650 μ A

3. Demagnetize the metal part of the chassis with the hand degausser and coil degausser, and the CRT surface with the hand degausser.
Input AC 230V to AC IN, turn on and off the power to perform auto degaussing. (Perform auto degaussing by setting "MON CON REG2"=152. Return to the original value after use.)
Demagnetize the CRT surface with the hand degausser again.
- (1) Adjust in a non-magnetic field. BV=55uT (SH Model).
- (2) If adjusting in a magnetic field, add the shift from the non-magnetic field in your estimation.
4. Attach the wobbling coil to the designated part of the CRT neck.
5. Pull the TLH plate hooked on stopper.
6. Attach the sensor of the landing adjustment unit on the CRT surface.
7. With landing checker adjust DY position, purity, DY tilt, DY center and landing of the 4 corners. Purity Adjustment use 2-pole Mg on DY side.
8. Fasten DY with screw.

Note: Torque 22 \pm 2kg-cm (2.2 \pm 0.2 Nm)
Perform auto degaussing.

<Specifications>

Adjust so that the green is within the specification given right.
4 corner adjust target : within \pm 1

_____ (μ m)		
0 \pm 5	0 \pm 7.5	0 \pm 5
0 \pm 5	0 \pm 5	0 \pm 5
0 \pm 5	0 \pm 7.5	0 \pm 5

The red and blue must be within the specification given right with respect to the green.

_____ (μ m)		
\pm 7	\pm 7	\pm 7
\pm 7	\pm 5	\pm 7
\pm 7	\pm 7	\pm 7

A difference between red and blue must be within the specification given right.

_____ (μ m)		
10	10	10
10	7	10
10	10	10

* Adjustment and measurement should be made at the points one inch inside the fluorescent screen.

Fixing DY with wedges.

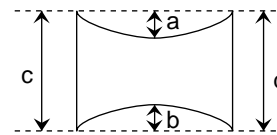

"a" and "b" must be equal, and "c" and "d" must be almost equal.

9. Adjust vertical swing with vertical pins, and also adjust horizontal swing so that horizontal keystone and vertical tilt are optimum, then fix with four wedges.
(When fixing DY with wedges, insert wedges completely so that the DY does not shake.)

Note:

- (1) Do not paste more than 2 magnets to one corner.
- (2) Paste within 80 to 100 mm from the DY on the diagonal line of the magnet.

<How to drive in wedges>

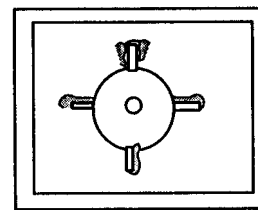

Apply a locking agent to the upper wedges only.
In such a case, apply agent so that it enters both sides of wedge and also inside the DY.

10. Check the landing of each corner, and if they do not satisfy the specification, paste a Disk-Mg onto the funnel and adjust.
11. If using the magnet, be sure to demagnetize with the hand degausser and check.
12. Remove the sensor and wobbling coil.
13. Check that the DY is not tilting, and fix the purity Mg with a white pen.

GDM-200PS/200PST/200PST9

Connect the communication cable of the computer to the connector located on the D board on the monitor. Run the service software and then follow the instruction.

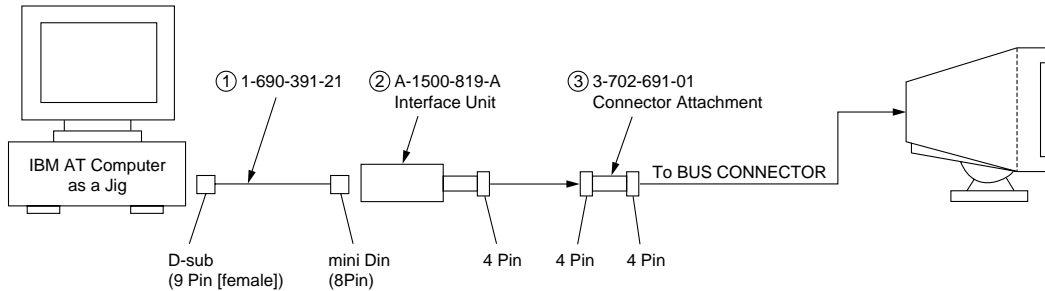

*The parts above (① ~ ③) are necessary for DAS adjustment.

• Convergence Rough Adjustment

- (1) Receive an image of the white crosshatch signals (white lines on black).
- (2) Place the protrusions of the 6-fold poles magnet attached to the CRT neck upon each other. (Fig. 1)
- (3) Make rough adjustment of the H and V direction convergence by using 4-fold poles magnet.

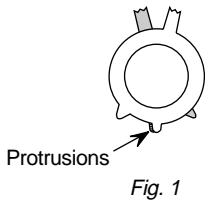

Fig. 1

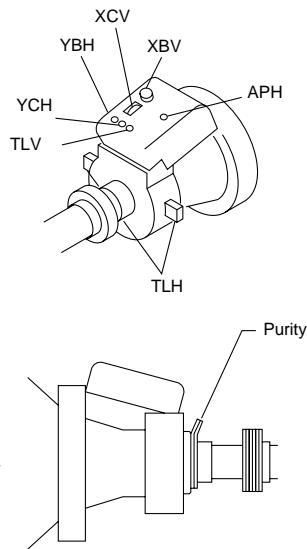
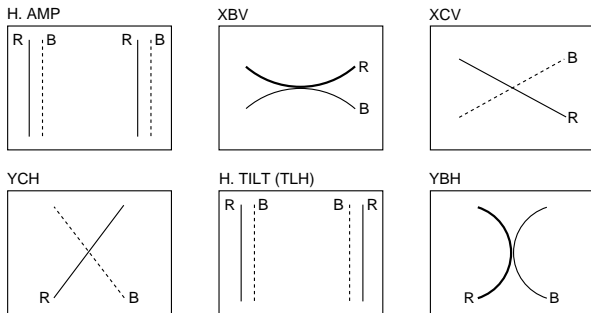
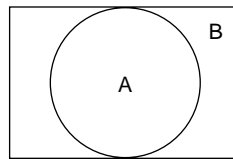

Fig. 3

* Set so that the protruding parts of the 2 magnet rings agree with each other.



• Convergence Specification



MODE	$f_H \geq 60 \text{ kHz}$	$f_H < 60 \text{ kHz}$
A	0.24 mm	0.24 mm
B	0.24 mm	0.32 mm
C	0.32 mm	0.36 mm

• White Balance Adjustment Specification

- (1) 9300K
 $x = 0.283 \pm 0.005$
 $y = 0.298 \pm 0.005$
 (All White)
- (2) 6500K
 $x = 0.313 \pm 0.005$
 $y = 0.329 \pm 0.005$
 (All White)

• Vertical and Horizontal Position and Size Specification

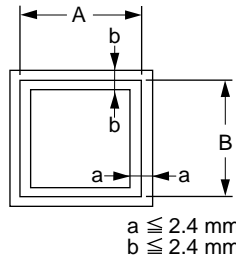

	4 : 3	5 : 4
A	312 mm	293 mm
B	234 mm	234 mm

• Focus adjustment

Adjust the focus volume 1 and 2 for the optimum focus.
 Standard: HMC, VMC $\pm 0.1 \text{ mm}$ (In the center of screen)

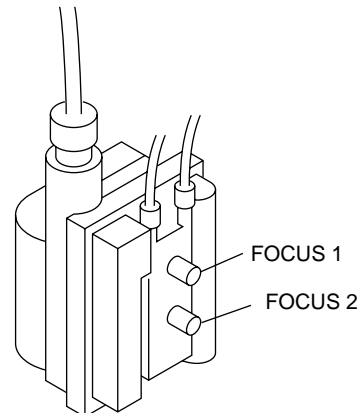

SECTION 5
DIAGRAMS

5-1. BLOCK DIAGRAMS (with FRAME SCHEMATIC DIAGRAM)

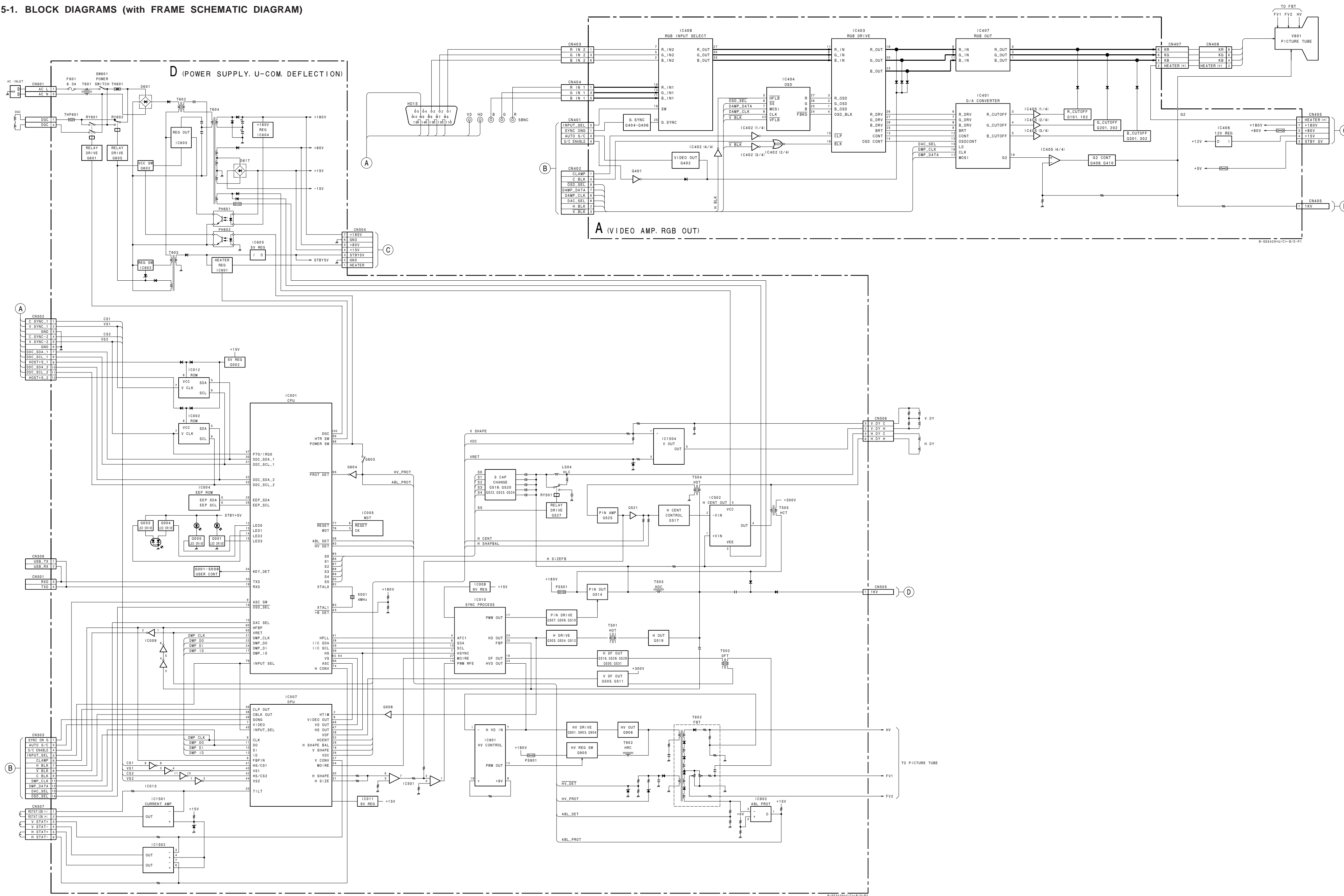

5-2. CIRCUIT BOARDS LOCATION

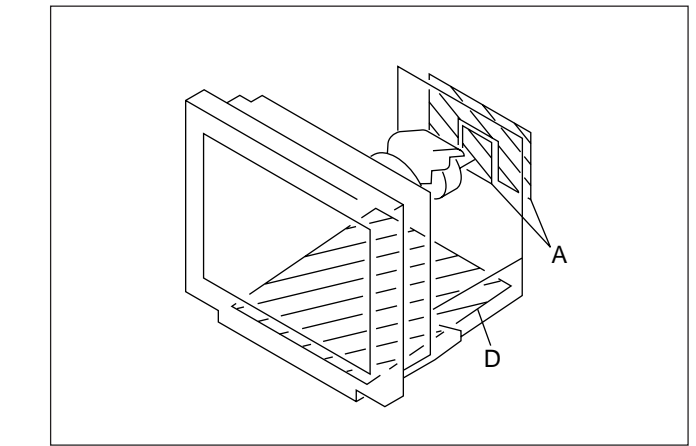

- All voltages are in V.
- Readings are taken with a 10 M digital multimeter.
- Readings are taken with a color-bar signal input.
- Voltage variations may be noted due to normal production tolerances.
- * : Can not be measured.
- Circled numbers are waveform references.
- — : B + bus.
- - - - : B - bus.

Note: The components identified by shading and mark Δ are critical for safety. Replace only with part number specified.

Note: Les composants identifiés par un trame et une marque Δ sont critiques pour la sécurité. Ne les remplacer que par une pièce portant le numéro spécifié.

5-3. SCHEMATIC DIAGRAMS AND PRINTED WIRING BOARDS

- Note:
- All capacitors are in μF unless otherwise noted. (pF: μpF)
 - Capacitors without voltage indication are all 50 V.
 - Indication of resistance, which does not have one for rating electrical power, is as follows.
- Pitch: 5 mm
Rating electrical power 1/4 W (CHIP: 1/10 W)
- All resistors are in ohms.
 - \square : nonflammable resistor.
 - \square : fusible resistor.
 - Δ : internal component.
 - \square : panel designation, and adjustment for repair.
 - All variable and adjustable resistors have characteristic curve B, unless otherwise noted.
 - \perp : earth-ground.
 - --- : earth-chassis.
 - The components identified by \square in this basic schematic diagram have been carefully factory-selected for each set in order to satisfy regulations regarding X-ray radiation. Should replacement be required, replace only with the value originally used.
 - When replacing components identified by \square , make the necessary adjustments indicated. (See page 3-1)
 - When replacing the part in below table, be sure to perform the related adjustment.

Part replaced (\square)	
HV ADJ	RV901
Part replaced (Δ)	
HV Regulator Circuit	D board IC901, R903, R922, T901 • Mounted D board
HV HOLD DOWN Circuit	D board D913, D916, C923, R920, R927, T901 • Mounted D board
Beam Current Protector Circuit	D board IC901, D902, D918, D919, R923, R928, R932, R933, R934, R942, R944, R945, R947, R948, R951, T901 • Mounted D board

Terminal name of semiconductors in silk screen printed circuit (\square)

Device	Printed symbol	Terminal name	Circuit
① Transistor		Collector Base Emitter	
② Transistor		Collector Base Emitter	
③ Diode		Cathode Anode	
④ Diode		Cathode Anode (NC)	
⑤ Diode		Cathode Anode (NC)	
⑥ Diode		Common Anode Cathode	
⑦ Diode		Common Anode Cathode	
⑧ Diode		Common Anode Cathode	
⑨ Diode		Common Anode Cathode	
⑩ Diode		Common Cathode Anode	
⑪ Diode		Common Cathode Anode	
⑫ Diode		Anode Cathode Anode Cathode	
⑬ Transistor (FET)		Drain Source Gate	
⑭ Transistor (FET)		Drain Source Gate	
⑮ Transistor (FET)		Source Drain Gate	
⑯ Transistor (FET)		Source Drain Gate	
⑰ Transistor		Emitter Collector Base	
⑱ Transistor		Emitter Collector Base	
—		Discrete semiconductor	

(Chip semiconductors that are not actually used are included.)

— D BOARD (Conductor Side) —

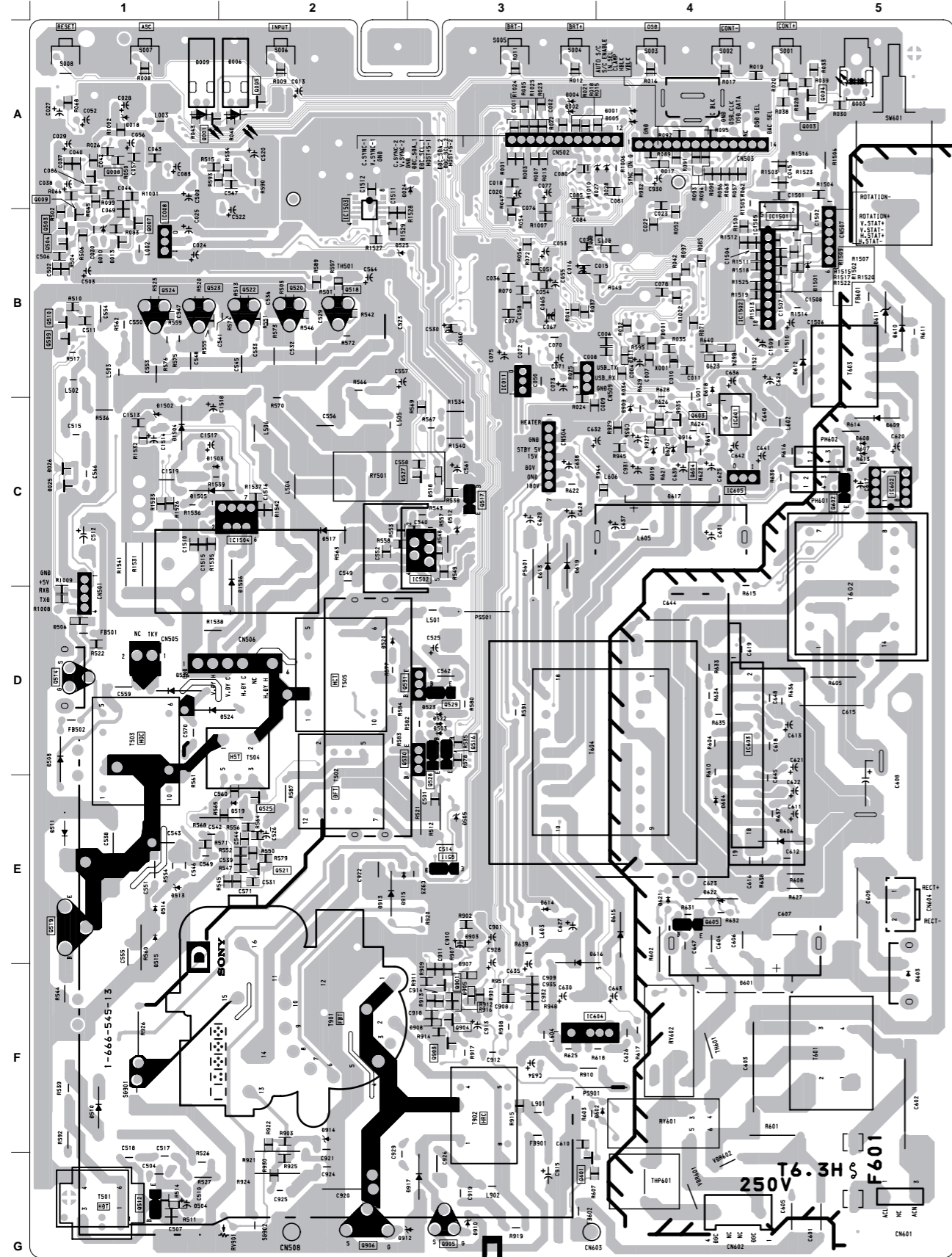

— D BOARD (Component Side) —

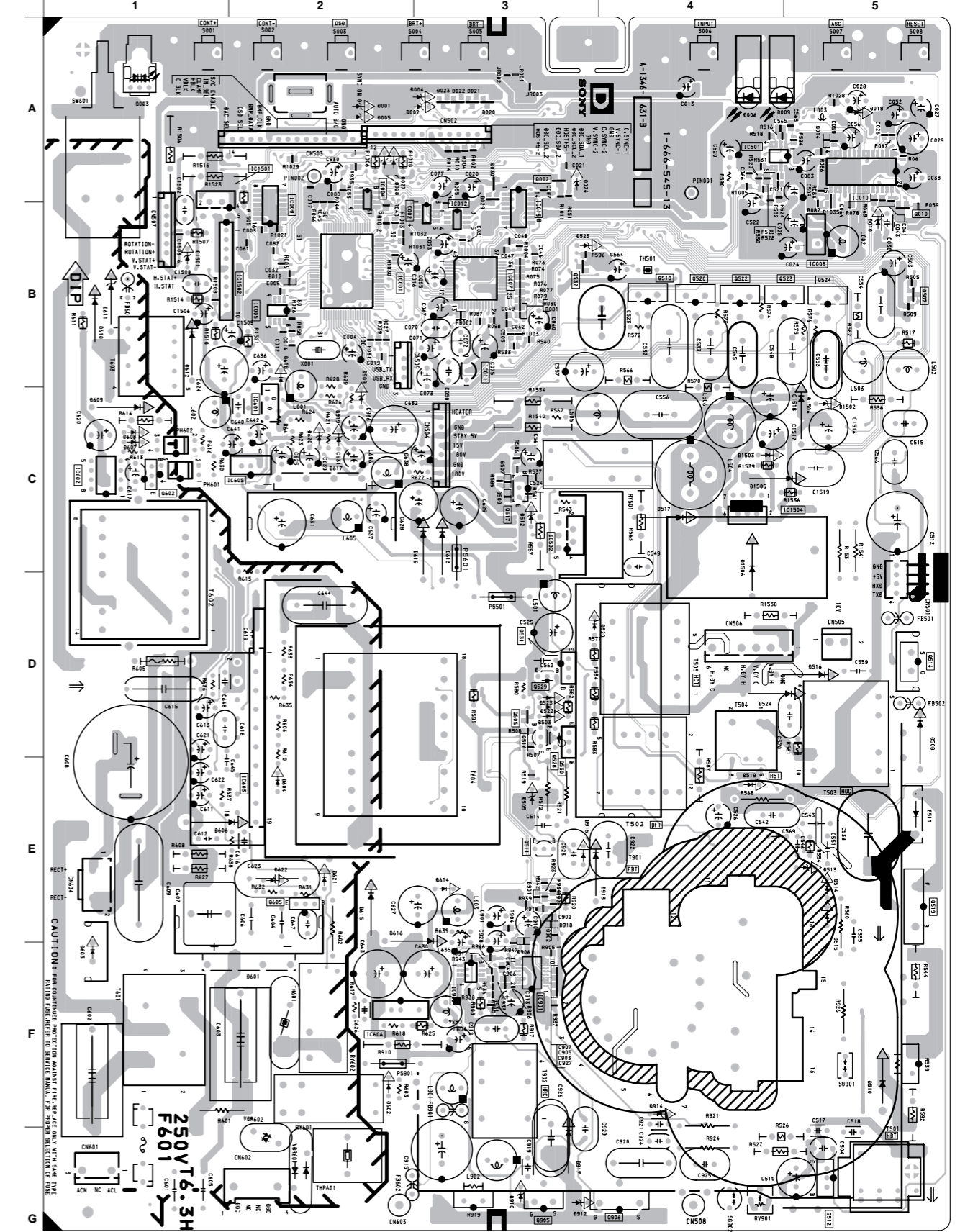

— A BOARD (Conductor Side) —

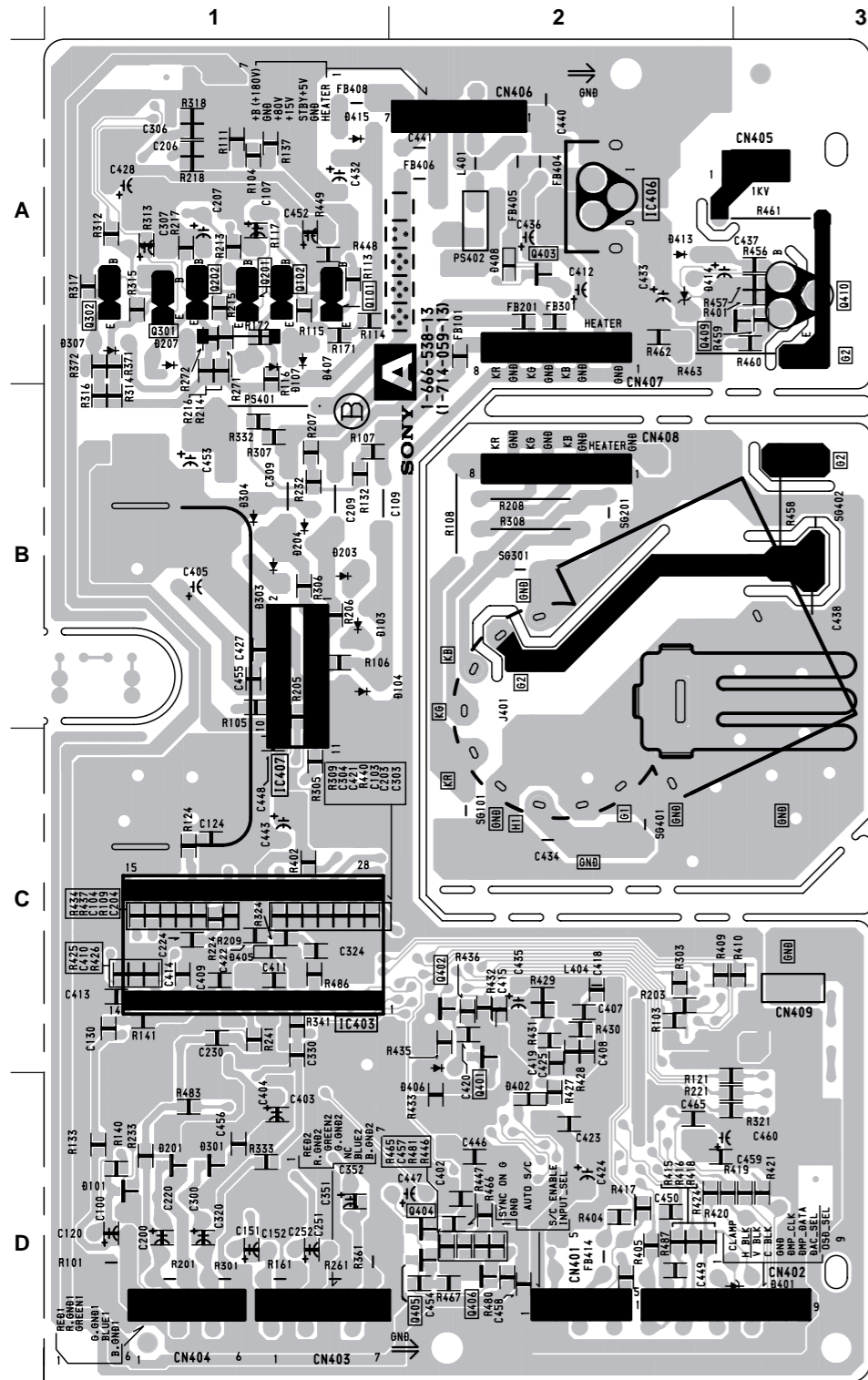

• A BOARD
SEMICONDUCTOR
LOCATION

IC	
(Conductor Side)	(Component Side)
IC401	D-1
IC402	D-2
IC403	C-1
IC404	C-1
IC405	A-2
IC406	A-1
IC407	B-1
IC408	B-2
IC409	D-2

TRANSISTOR	
(Conductor Side)	(Component Side)*
Q101	A-1 A-2 -
Q102	A-1 A-2 -
Q201	A-1 A-2 -
Q202	A-1 A-2 -
Q301	A-1 A-3 -
Q302	A-1 A-3 -
Q401	C-2 - (1)
Q402	C-2 - (2)
Q404	D-2 - (3)
Q405	D-2 - (4)
Q406	D-2 - (5)
Q409	A-3 - (6)
Q410	A-3 A-1 -

DIODE	
(Conductor Side)	(Component Side)*
D101	D-1 (7)
D103	B-1 B-2 -
D104	B-1 B-2 -
D105	B-2 - (8)
D106	C-2 - (9)
D111	D-2 - (10)
D201	D-1 (11)
D203	B-1 B-2 -
D204	B-1 B-2 -
D205	B-2 - (12)
D206	C-2 - (13)
D211	D-2 - (14)
D301	D-1 (15)
D303	B-1 B-2 -
D304	B-1 B-2 -
D305	B-2 - (16)
D306	C-2 - (17)
D311	D-2 - (18)
D401	D-3 D-1 -
D406	D-2 D-2 -
D413	A-2 A-1 -
D414	A-2 A-1 -
D415	A-1 A-2 -

*: Refer to Terminal name of semiconductors in silk screen printed circuit (see page 5-4)

— A BOARD (Component Side) —

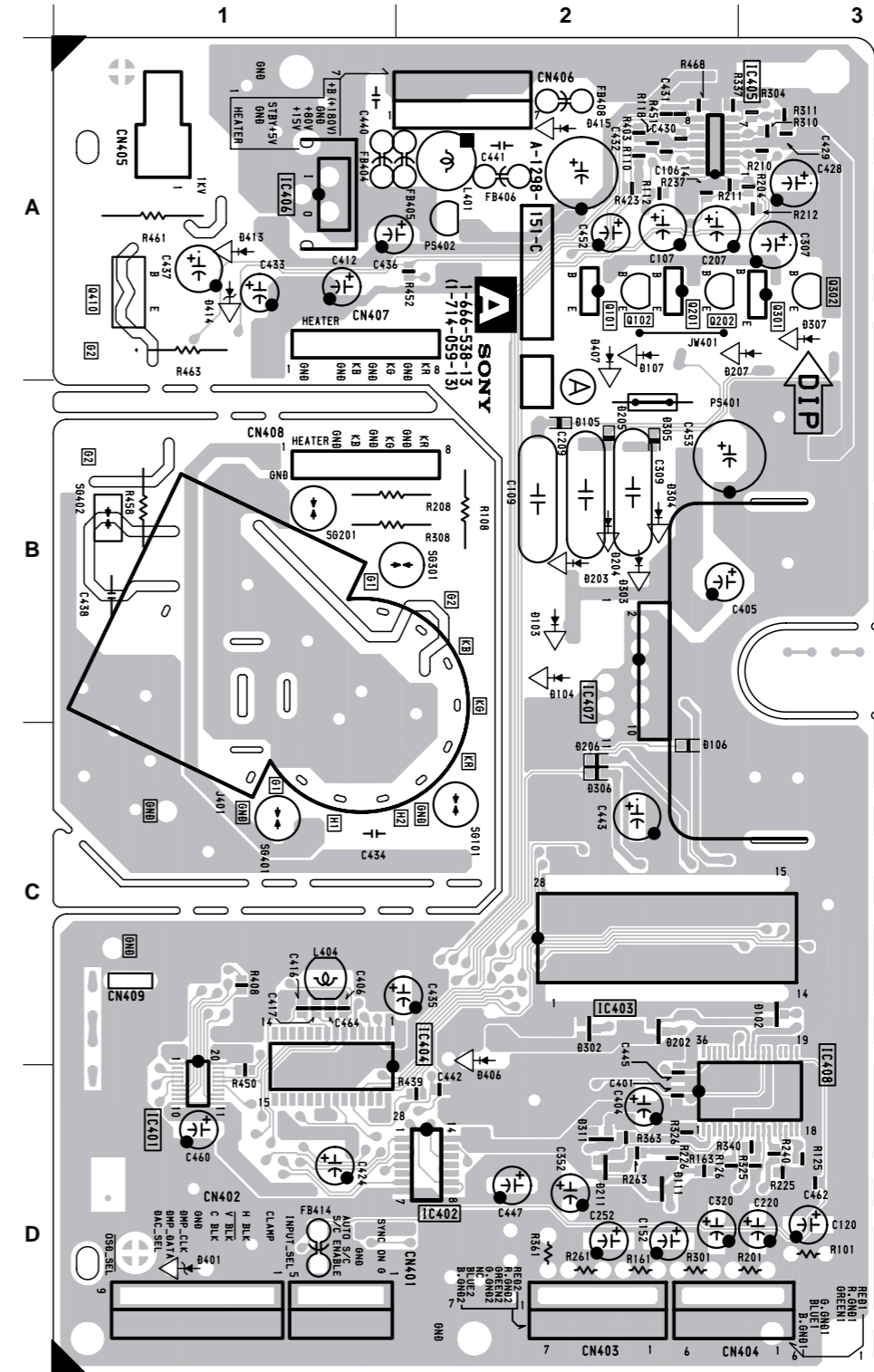

NOTE:
The circuit indicated as left contains high voltage of over 600 Vp-p. Care must be paid to prevent an electric shock in inspection or repairing.

(2) Schematic Diagrams of A Board

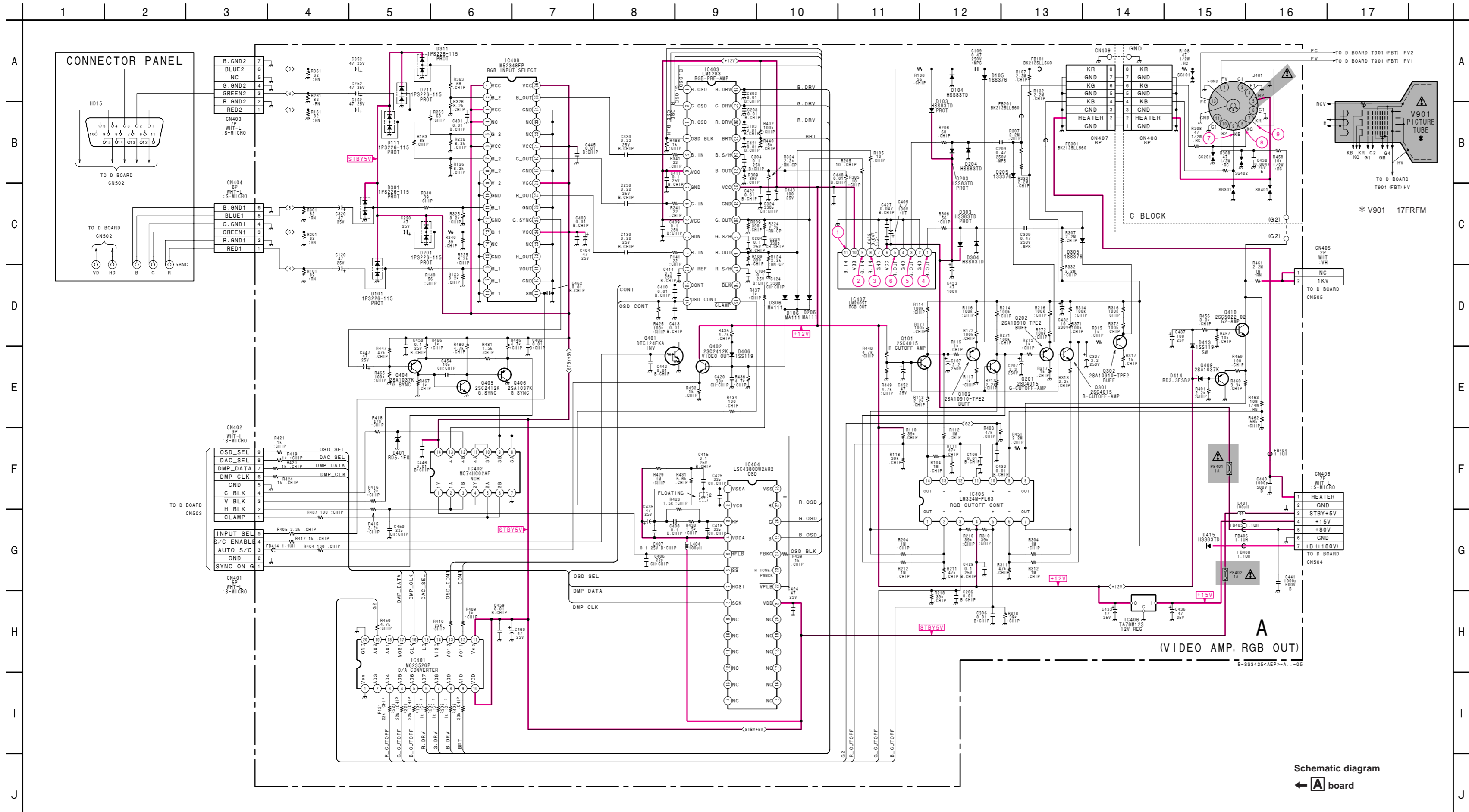

• A BOARD WAVEFORMS

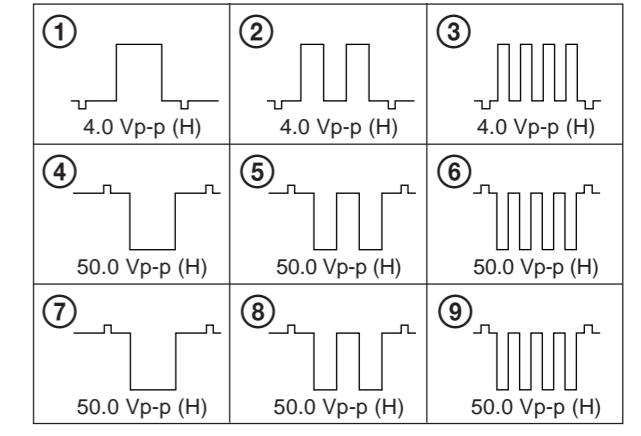

• A BOARD VOLTAGE LIST

Ref.	Pin No.	Voltage [V]	Ref.	Pin No.	Voltage [V]	
IC403	1	1.6	Q202	B	91.7	
	2	1.6		C	0.6	
	3	1.6		E	92.3	
	4	0		Q301	B	5.8
	5	2.2			C	92.1
	8	2.2			E	5.2
	12	2		Q302	B	92.1
	13	1.7			C	0.6
	14	1.5			E	92.7
	15	4.8		Q401	B	0
	16	4			C	6.1
17	6.7	E	6.1			
18	2.2	Q402	B	5.5		
19	6.8		E	4.8		
20	2.1	Q404	B	3.5		
23	2.1		C	0.6		
24	6.8		E	4.1		
25	1.5	Q405	B	0.6		
26	3.4		C	3.3		
IC407	1	50.6	Q406	B	3.3	
	3	50.6		E	3.6	
	5	50.6		Q409	B	8.3
	8	2.1			E	7.8
9	2.1	Q410	B	8.3		
11	2.1		C	463		
			E	7.8		
Q101	B	5.8	J401	KB	70	
	C	93.3		KG	70	
	E	5.2		KR	70	
Q102	B	93.3	G2	462		
	C	0.6	H2	6.2		
	E	94				
Q201	B	5.8				
	C	91.7				
	E	5.2				

Schematic diagram
← A board

5-4. SEMICONDUCTORS

BA10393F
 NJM4558M
 μPC4558G2
 24LC16BT/SN
 24LC21A/SN

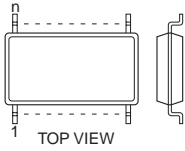

BA9756F-E2
 M62352GP-75E
 M62352GP-75ED

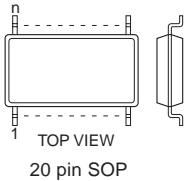

CAX2043Q

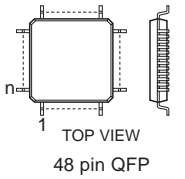

CXA2044M
 LSC4380DW2AR2

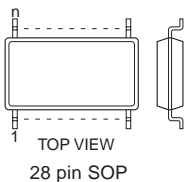

DM-57N

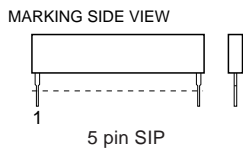

LA6500-FA

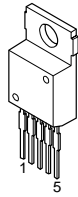

LA6510

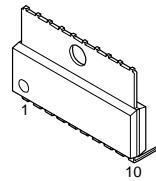

LM1283N

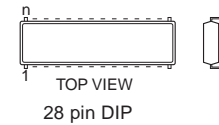

LM2405T

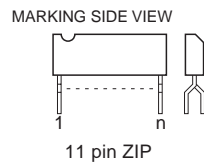

LM324M
 MC74HC02AF
 SN74HC02ANS
 SN74HC04ANS
 SN74HCT04ANS

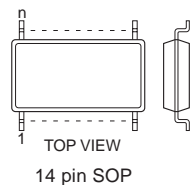

MB90P553PF-G-120-BND

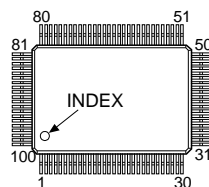

MCR5102

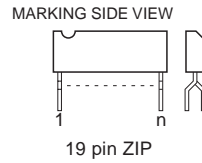

MM1170BFB
 PQ6RD83B
 TOP223PF1

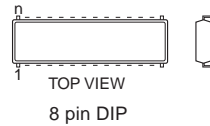

M52755FP

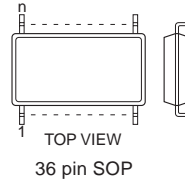

NJM78L09A
 TA78L09S

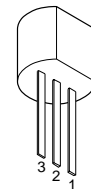

NJM78M09FA
 TA78M12S
 TA7805S

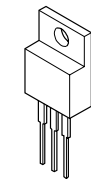

TDA8172

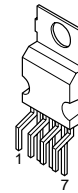

BU2527AX-ON5020

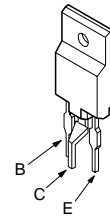

DTA114GKAT146
 DTA124EKA-T146
 DTC114GKA
 DTC114GKAT146
 DTC124EK
 DTC124EKA-T146
 2SA1036K-Q
 2SA1036K-T-146-Q
 2SA1037K-T-146-QR
 2SC1623-L5L6
 2SC2412K-T-146-QR

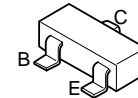

DTA124ESA
 2SC2459-GR
 2SC2784
 2SC2785-HFE
 2SC3311A-RTA

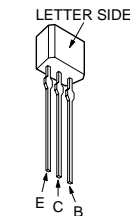

IRLI530GLF33

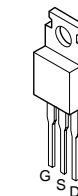

IRLI540GLF33

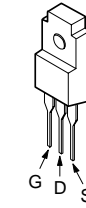

IRFPE50LF21

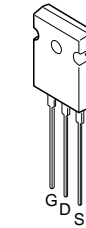

2SA1049-GR

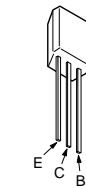

2SA1091-O
 2SC2362K-G

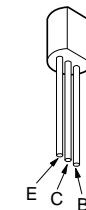

2SA1358-Y
 2SC3421-Y

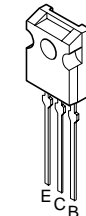

2SC2362KG-AA

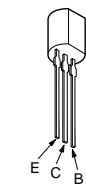

2SC3209LK

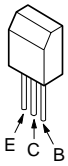

DTZ-10B
DTZ-13B
DTZ-5.1B
MA111-TX
RD12SB2
UDZ-TE-17-10B
UDZ-TE-17-12B
UDZ-TE-17-13B
UDZ-TE-17-22B
UDZ-TE-17-5.1B

D2L40-TA
D4SBS4
D4SBS4-F
D4SB60L

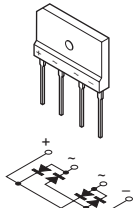

PC123F2
PC123FY2

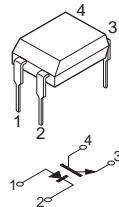

SEL1922D-C
SEL1922D-C, D

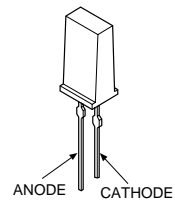

2SC3941A-Q(TA)

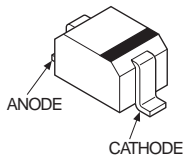
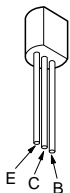

D2S4MF
D2S4MTA1

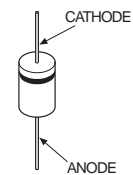

P6KE170AG23
SB340L-6489

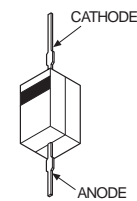

SPB-26MVWF

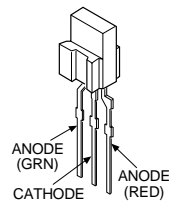

2SC4015TV2

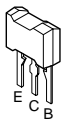

D1NS4
D1NL20-TR
EGP10GPKG23
RD12ES-B2
RD13ES-B2
RD16ES-B2
RD16ES-B3
RD24ES-B2
RE24ES-B3
RD3.3ES-B2
RD5.1ES-B2
RD6.8ES-B1
RD7.5ES-B1
1SS119-25TD
1SS119-25

D5L60
FMQ-G5FMS
PG124S15

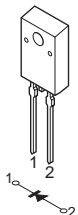

RD7.5M-B2

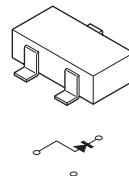

2SC5022-02
2SJ449
2SJ449(1)

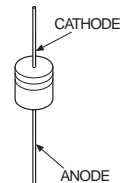
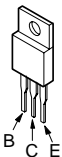

EGP10D
ERA91-02
RGP10JPKG23
S2LA20F

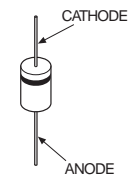

SB340

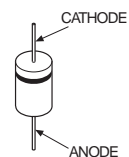

2SDS1802-S

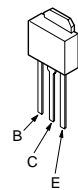

D1NS4-TR
D2L20U
EL1Z
ERA22-06AVRBT
ERA22-08
GP08D
GP08DPKG23
HSS83TD
RPG02-17EL-6433
RPG02-17PKG23
RGP10GPKG23
UF4005PKG23

MA151WK
1SS184

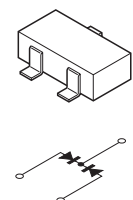

1PS226-115

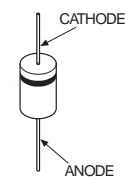
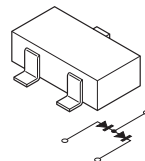

1SS376TE-17

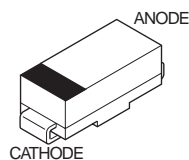

SECTION 6 EXPLODED VIEWS

- Items with no part number and no description are not stocked because they are seldom required for routine service.
- The construction parts of an assembled part are indicated with a collation number in the remark column.
- Items marked " * " are not stocked since they are seldom required for routine service. Some delay should be anticipated when ordering these items.

The components identified by shading and mark \triangle are critical for safety. Replace only with part number specified.

Les composants identifiés par un tramé et une marque \triangle sont critiques pour la sécurité. Ne les remplacer que par une pièce portant le numéro spécifié.

6-1. CHASSIS

- ▲ 7-685-647-79 +BVTP 3X10
- 7-685-663-71 +BVTP 4X16
- △ 7-685-872-09 +BVTT 3X8
- 7-685-881-09 +BVTT 4X8

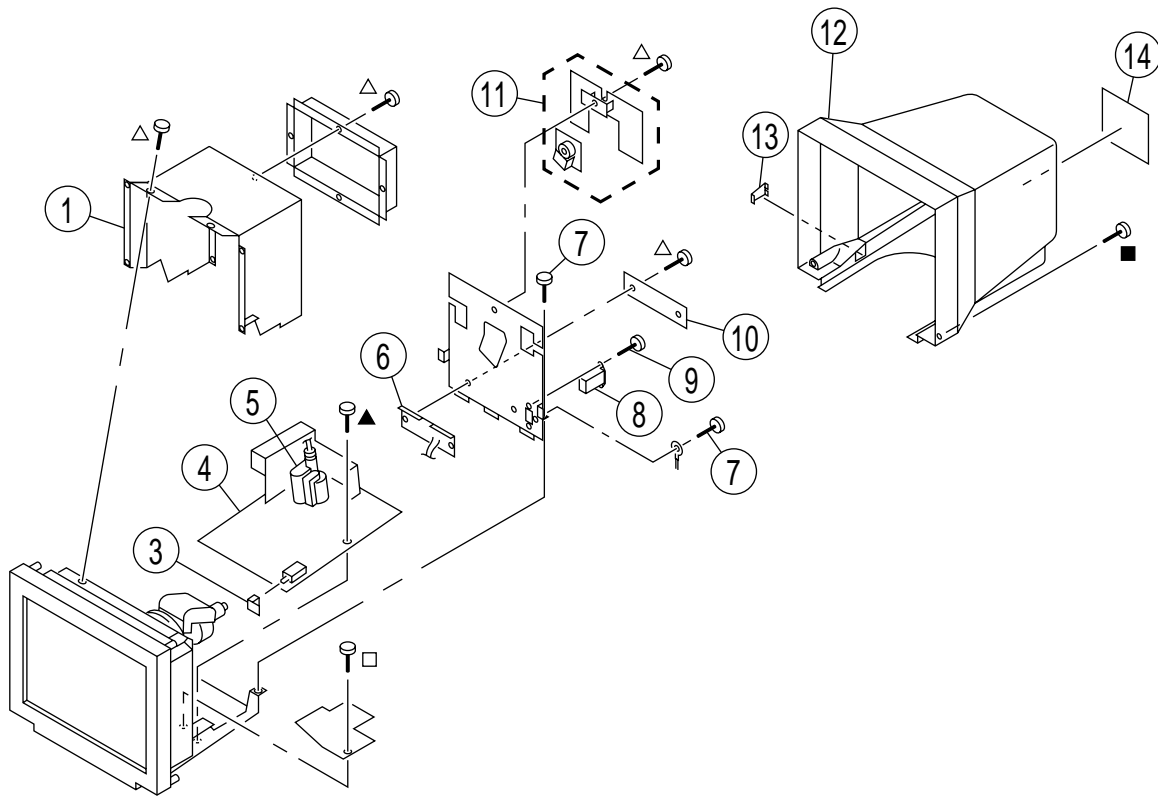

REF.NO.	PART NO.	DESCRIPTION	REMARK	REF.NO.	PART NO.	DESCRIPTION	REMARK
1	* X-4034-844-1	SHIELD ASSY, EMI [U/C, SH model]		12	X-4034-867-1	CABINET ASSY [AEP, UK model]	13
1	* X-4035-398-1	SHIELD ASSY, EMI [AEP, UK model]		12	4-060-696-01	CABINET [U/C for USA-made set]	
3	* 4-394-972-21	CAP, POWER		13	4-060-401-11	COVER, ECS	
4	* A-1346-713-B	D BOARD, COMPLETE	5			[U/C for Japan-made set, SH model]	
5	△ X-4035-177-1	TRANSFORMER ASSY, FLYBACK (NX-4401//J1M4)		13	4-060-528-01	COVER, ECS [AEP, UK model]	
6	1-694-347-11	TERMINAL BOARD ASSY, I/O		13	4-060-704-01	COVER, ECS [U/C for USA-made set]	
7	4-389-025-01	SCREW (M4) (EXT TOOTH WASHER)		14	* 4-061-169-01	LABEL, INFORMATION	
8	△ 1-251-382-22	INLET, AC 3P(WITH NOISE FILTE)				[U/C for Japan-made set, SH model]	
9	4-052-345-01	SCREW, (3X8) (+K), TAPPING		14	* 4-061-169-12	LABEL, INFORMATION	
10	4-060-368-12	SHEET, CONNECTOR				[U/C for USA-made set]	
11	* 8-933-248-00	A BOARD, COMPLETE		14	* 4-061-170-01	LABEL, INFORMATION	
12	4-060-394-12	CABINET				[200PST AEP, UK model]	
		[U/C for Japan-made set, SH model]		14	4-204-887-01	LABEL, INFORMATION [200PST9]	

6-2. PICTURE TUBE

- ▲ 7-685-647-79 +BVTP 3X10
- 7-685-663-71 +BVTP 4X16
- 7-685-881-09 +BVTT 4X8
- ◇ 7-685-661-79 +P 4X12

The components identified by shading and mark ▲ are critical for safety. Replace only with part number specified.

Les composants identifiés par un trame et une marque ▲ sont critiques pour la sécurité. Ne les remplacer que par une pièce portant le numéro spécifié.

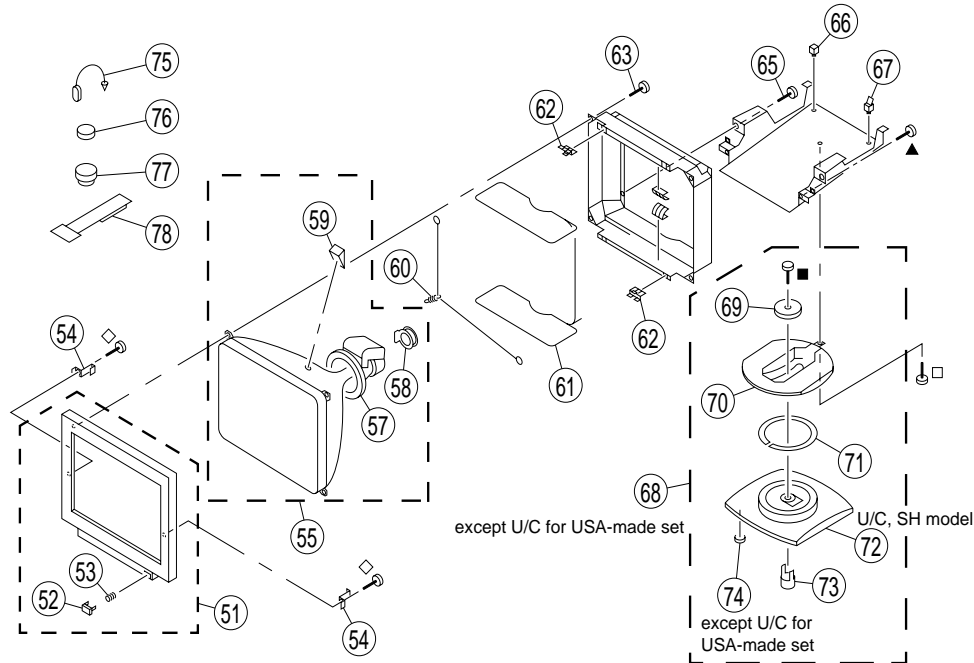

REF.NO.	PART NO.	DESCRIPTION	REMARK	REF.NO.	PART NO.	DESCRIPTION	REMARK
51	X-4034-845-1	BEZEL ASSY [U/C for Japan-made set, SH model]	52, 53	63	4-365-808-01	SCREW (5), TAPPING [U/C, SH model]	
51	X-4034-866-1	BEZEL ASSY [AEP, UK model]	52, 53	65	4-389-025-01	SCREW (M4) (EXT TOOTH WASHER)	
51	X-4034-887-1	BEZEL ASSY [U/C for USA-made set]	52, 53	66	* 4-382-848-01	HOLDER, PRINTED CIRCUIT BOARD	
52	4-060-420-01	BUTTON, POWER [U/C for Japan-made set, SH model]		67	* 3-703-141-00	HOLDER, PRINTED CIRCUIT BOARD	
52	4-060-523-01	BUTTON, POWER [AEP, UK model]		68	X-4034-847-1	STAND ASSY [U/C for Japan-made set, SH model]	69-74
52	4-060-699-01	BUTTON, POWER [U/C for USA-made set]		68	X-4034-868-1	STAND ASSY [AEP, UK model]	69-74
53	3-653-339-21	SPRING, COMPRESSION [U/C for USA-made set]		69	4-060-340-01	STOPPER (A) [U/C for Japan-made set, SH model]	
53	3-653-339-01	SPRING, COMPRESSION [U/C for Japan-made set, SH model]		69	4-060-644-02	STOPPER (A) [AEP, UK model]	
53	3-653-339-11	SPRING, COMPRESSION [AEP, UK model]		69	4-060-531-01	STOPPER (A) [U/C for USA-made set]	
54	4-052-459-11	HOOK (17) [U/C for USA-made set]		70	4-060-396-11	SLIDER [U/C for Japan-made set, SH model]	
54	4-052-459-01	HOOK (17) [except U/C for USA-made set]		70	4-060-522-01	SLIDER [AEP, UK model]	
55	▲ 8-738-728-80	ITC ASSY (17FRFM-RS1) [SH model]	57-59	70	4-060-698-01	SLIDER [U/C for USA-made set]	
55	▲ 8-738-733-81	ITC ASSY (17FRFM-R1) [except SH model]	57-59	71	4-060-339-01	RING, TILT SWIVEL [U/C for Japan-made set, SH model]	
57	▲ 8-451-488-11	DEFLECTION YOKE (Y17FRJ-M)		71	4-060-643-01	RING, TILT SWIVEL [APE, UK model]	
58	▲ 1-452-923-21	NECK ASSEMBLY		71	4-060-705-01	RING, TILT SWIVEL [U/C for USA-made set]	
59	4-040-897-01	SPACER, DY [U/C for USA-made set]		72	X-4034-851-1	BASE ASSY, STAND [U/C for Japan-made set, SH model]	74
59	4-050-492-01	SPACER, DY [except U/C for USA-made set]		72	X-4034-890-1	BASE ASSY, STAND [U/C for USA-made set]	
60	* 4-047-316-01	SPRING, EXTENSION [except U/C for USA-made set]		73	4-041-621-21	STOPPER (B) [U/C for USA-made set]	
60	* 4-061-573-01	SPRING, TENSION [U/C for USA-made set]		73	4-041-621-01	STOPPER (B) [except U/C for USA-made set]	
61	▲ 1-416-282-41	COIL, DEMAGNETIC		74	4-047-474-01	FOOT, RUBBER [except U/C for USA-made set]	
62	* 4-056-260-01	SPACER, DEGAUSSER COIL		75	4-308-870-00	CLIP, LEAD WIRE	
63	4-203-648-01	SCREW (5), SELF TAPPING [AEP, UK model]		76	1-452-032-00	MAGNET, DISC ; 10 mmφ	
				77	1-452-094-00	MAGNET, ROTABLE DISK; 15mmφ	
				78	4-059-493-01	PERMALLOY (90), CONV.CORRECT	

The components identified by shading and mark Δ are critical for safety. Replace only with part number specified.

Les composants identifiés par un trame et une marque Δ sont critiques pour la sécurité. Ne les remplacer que par une pièce portant le numéro spécifié.

6-3. PACKING MATERIALS

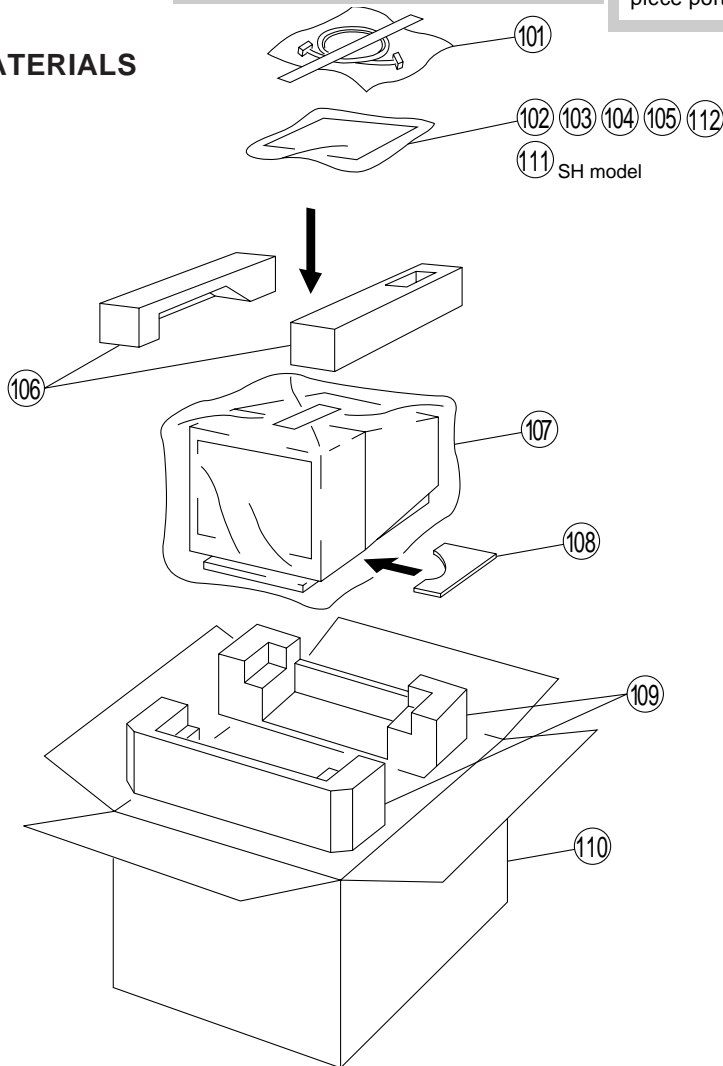

REF.NO.	PART NO.	DESCRIPTION	REMARK	REF.NO.	PART NO.	DESCRIPTION	REMARK
101	1-777-743-11	CABLE ASSY (15PDSUBX2CONNECTOR) [U/C, SH model]		106	*4-060-006-01	CUSHION (UPPER) (ASSY) [U/C for Japan-made set, SH model]	
101	1-790-212-11	CABLE ASSY [AEP, UK model]		107	*4-041-927-11	BAG, POLYETHYLENE [U/C, SH model]	
102	1-573-983-31	ADAPTOR, CONVERSION (for Macintosh)		107	*4-060-490-01	BAG, POLYETHYLENE [AEP, UK model]	
103	Δ 1-558-481-11	CORD SET, POWER (10A/250V) [SH model]		108	*4-060-581-01	PAD FOR TILT FIXING [U/C for USA-made set]	
103	Δ 1-790-714-11	CORD SET, POEWR (10A/250V) [AEP model]		108	*4-060-012-01	PAD FOR TILT FIXING [U/C for Japan-made set, SH model]	
103	Δ 1-765-718-11	CORD SET, POWER (10A/125V) [U/C model]		108	*4-060-588-01	PAD FOR TILT FIXING [AEP, UK model]	
103	Δ 1-775-706-11	CORD SET, POWER (10A/250V) [UK model]		109	*4-060-575-01	CUSHION (LOWER) (ASSY) [U/C for USA-made set]	
104	3-861-050-11	MANUAL, INSTRUCTION [U/C for Japan-made set, SH model]		109	*4-060-007-01	CUSHION (LOWER) (ASSY) [U/C for Japan-made set, SH model]	
104	3-861-050-21	MANUAL, INSTRUCTION [U/C for USA-made set]		109	*4-060-583-01	CUSHION (LOWER) (ASSY) [AEP, UK model]	
104	3-861-051-11	MANUAL, INSTRUCTION [200PST AEP, UK model]		110	*4-060-589-01	INDIVIDUAL CARTON [U/C for Japan-made set, SH model]	
104	3-861-051-31	MANUAL, INSTRUCTION [200PST9]		110	*4-060-590-01	INDIVIDUAL CARTON [U/C for USA-made set]	
105	1-759-641-21	DISK, INFORMATION (WINDOWS, 3.5") [U/C for USA-made set]		110	*4-060-591-01	INDIVIDUAL CARTON [200PST AEP, UK model]	
105	1-759-641-14	DISK, INFORMATION (WINDOWS, 3.5") [except U/C for USA-made set]		110	*4-204-889-01	INDIVIDUAL CARTON [200PST9]	
106	*4-060-582-01	CUSHION (UPPER) (ASSY) [AEP, UK model]		111	1-774-648-21	ADAPTOR, CONVERSION (for VGA) [SH model]	
106	*4-060-574-01	CUSHION (UPPER) (ASSY) [U/C for USA-made set]		112	1-785-429-11	ADAPTOR, CONVERSION (for Mac)	

SECTION 7 ELECTRICAL PARTS LIST

GDM-200PS/200PST/200PST9



NOTE:

The components identified by shading and mark \triangle are critical for safety. Replace only with part number specified.

Les composants identifiés par un tramé et une marque \triangle sont critiques pour la sécurité. Ne les remplacer que par une pièce portant le numéro spécifié.

When indicating parts by reference number, please include the board name.

The components identified by \square in this manual have been carefully factory-selected for each set in order to satisfy regulations regarding X-ray radiation. Should replacement be required, replace only with the value originally used.

- All variable and adjustable resistors have characteristic curve B, unless otherwise noted.

RESISTORS

- All resistors are in ohms
- F : nonflammable
- Items marked " * " are not stocked since they are seldom required for routine service. Some delay should be anticipated when ordering these items.

REF.NO.	PART NO.	DESCRIPTION	REMARK	REF.NO.	PART NO.	DESCRIPTION	REMARK
	* A-1298-233-BA BOARD, COMPLETE *****			C410	1-164-232-11	CERAMIC CHIP 0.01 μ F	10% 50V
				C411	1-164-004-11	CERAMIC CHIP 0.1 μ F	10% 25V
				C413	1-164-232-11	CERAMIC CHIP 0.01 μ F	10% 50V
	4-382-854-11	SCREW (M3X10), P, SW (+) (IC406, IC407)		C414	1-164-004-11	CERAMIC CHIP 0.1 μ F	10% 25V
	<CAPACITOR>			C415	1-164-004-11	CERAMIC CHIP 0.1 μ F	10% 25V
C103	1-164-232-11	CERAMIC CHIP 0.01 μ F	10% 50V	C418	1-163-235-11	CERAMIC CHIP 22pF	5% 50V
C104	1-164-004-11	CERAMIC CHIP 0.1 μ F	10% 25V	C420	1-163-222-11	CERAMIC CHIP 5pF	0.25pF50V
C106	1-164-232-11	CERAMIC CHIP 0.01 μ F	10% 50V	C421	1-164-232-11	CERAMIC CHIP 0.01 μ F	10% 50V
C107	1-107-649-11	ELECT 2.2 μ F	20% 250V	C422	1-164-232-11	CERAMIC CHIP 0.01 μ F	10% 50V
C109	1-117-450-11	FILM 0.47 μ F	10% 250V	C424	1-104-664-11	ELECT 47 μ F	20% 25V
C120	1-104-664-11	ELECT 47 μ F	20% 25V	C425	1-163-235-11	CERAMIC CHIP 22pF	5% 50V
C124	1-163-263-11	CERAMIC CHIP 330pF	5% 50V	C427	1-104-760-11	CERAMIC CHIP 0.047 μ F	10% 50V
C130	1-115-340-11	CERAMIC CHIP 0.22 μ F	10% 25V	C429	1-164-004-11	CERAMIC CHIP 0.1 μ F	10% 25V
C152	1-104-664-11	ELECT 47 μ F	20% 25V	C430	1-164-232-11	CERAMIC CHIP 0.01 μ F	10% 50V
C203	1-164-232-11	CERAMIC CHIP 0.01 μ F	10% 50V	C432	1-107-652-11	ELECT 10 μ F	20% 200V
C204	1-164-004-11	CERAMIC CHIP 0.1 μ F	10% 25V	C433	1-104-664-11	ELECT 47 μ F	20% 25V
C206	1-164-232-11	CERAMIC CHIP 0.01 μ F	10% 50V	C435	1-104-664-11	ELECT 47 μ F	20% 25V
C207	1-107-649-11	ELECT 2.2 μ F	20% 250V	C436	1-104-664-11	ELECT 47 μ F	20% 25V
C209	1-117-450-11	FILM 0.47 μ F	10% 250V	C437	1-104-665-11	ELECT 100 μ F	20% 25V
C220	1-104-664-11	ELECT 47 μ F	20% 25V	C438	1-162-114-00	CERAMIC 0.0047 μ F	2KV
C224	1-163-263-11	CERAMIC CHIP 330pF	5% 50V	C440	1-162-318-11	CERAMIC 0.001 μ F	10% 500V
C230	1-115-340-11	CERAMIC CHIP 0.22 μ F	10% 25V	C441	1-162-318-11	CERAMIC 0.001 μ F	10% 500V
C252	1-104-664-11	ELECT 47 μ F	20% 25V	C442	1-164-232-11	CERAMIC CHIP 0.01 μ F	10% 50V
C303	1-164-232-11	CERAMIC CHIP 0.01 μ F	10% 50V	C443	1-104-665-11	ELECT 100 μ F	20% 25V
C304	1-164-004-11	CERAMIC CHIP 0.1 μ F	10% 25V	C445	1-164-232-11	CERAMIC CHIP 0.01 μ F	10% 50V
C306	1-164-232-11	CERAMIC CHIP 0.01 μ F	10% 50V	C446	1-164-232-11	CERAMIC CHIP 0.01 μ F	10% 50V
C307	1-107-649-11	ELECT 2.2 μ F	20% 250V	C447	1-104-664-11	ELECT 47 μ F	20% 25V
C309	1-117-450-11	FILM 0.47 μ F	10% 250V	C448	1-164-232-11	CERAMIC CHIP 0.01 μ F	10% 50V
C320	1-104-664-11	ELECT 47 μ F	20% 25V	C450	1-163-235-11	CERAMIC CHIP 22pF	5% 50V
C324	1-163-263-11	CERAMIC CHIP 330pF	5% 50V	C452	1-104-664-11	ELECT 47 μ F	20% 25V
C330	1-115-340-11	CERAMIC CHIP 0.22 μ F	10% 25V	C453	1-128-562-11	ELECT 47 μ F	20% 100V
C352	1-104-664-11	ELECT 47 μ F	20% 25V	C454	1-163-227-11	CERAMIC CHIP 10pF	0.5pF 50V
C401	1-164-232-11	CERAMIC CHIP 0.01 μ F	10% 50V	C455	1-104-760-11	CERAMIC CHIP 0.047 μ F	10% 50V
C402	1-164-232-11	CERAMIC CHIP 0.01 μ F	10% 50V	C458	1-164-004-11	CERAMIC CHIP 0.1 μ F	10% 25V
C403	1-164-232-11	CERAMIC CHIP 0.01 μ F	10% 50V	C459	1-164-232-11	CERAMIC CHIP 0.01 μ F	10% 50V
C404	1-104-664-11	ELECT 47 μ F	20% 25V	C460	1-104-664-11	ELECT 47 μ F	20% 25V
C405	1-107-928-11	ELECT 4.7 μ F	20% 100V	C462	1-164-232-11	CERAMIC CHIP 0.01 μ F	10% 50V
C406	1-163-235-11	CERAMIC CHIP 22pF	5% 50V	<CONNECTOR>			
C407	1-164-004-11	CERAMIC CHIP 0.1 μ F	10% 25V	CN401*	1-564-520-11	PLUG, CONNECTOR 5P	
C408	1-164-004-11	CERAMIC CHIP 0.1 μ F	10% 25V	CN402*	1-564-524-11	PLUG, CONNECTOR 9P	
C409	1-164-004-11	CERAMIC CHIP 0.1 μ F	10% 25V	CN403*	1-564-522-11	PLUG, CONNECTOR 7P	

GDM-200PS/200PST/200PST9



Les composants identifiés par un tramé et une marque Δ sont critiques pour la sécurité. Ne les remplacer que par une pièce portant le numéro spécifié.

The components identified by shading and mark Δ are critical for safety. Replace only with part number specified.

REF.NO.	PART NO.	DESCRIPTION	REMARK	REF.NO.	PART NO.	DESCRIPTION	REMARK
		CN404*1-564-521-11 PLUG, CONNECTOR 6P				<JACK>	
		CN405*1-766-179-11 PIN, CONNECTOR (PC BOARD) 2P				J401 Δ 1-251-598-11 SOCKET, PICTURE TUBE	
		CN406*1-564-522-11 PLUG, CONNECTOR 7P				<COIL>	
		CN409 1-695-915-11 TAB (CONTACT)				L401 1-412-537-31 INDUCTOR 100 μ H	
		<DIODE>				L402 1-408-615-31 INDUCTOR 100 μ H	
		D101 8-719-062-51 DIODE 1PS226-115				L404 1-414-189-31 INDUCTOR 100 μ H	
		D103 8-719-051-85 DIODE HSS83TD				<IC LINK>	
		D104 8-719-051-85 DIODE HSS83TD				PS401 Δ 1-533-590-31 LINK, IC (1A/90V AC, 60V DC)	
		D105 8-719-052-12 DIODE 1SS376TE-17				PS402 Δ 1-532-637-91 LINK, IC (1A/150V)	
		D106 8-719-404-50 DIODE MA111-TX				<TRANSISTOR>	
		D111 8-719-062-51 DIODE 1PS226-115				Q101 8-729-041-66 TRANSISTOR 2SC4015TV2	
		D201 8-719-062-51 DIODE 1PS226-115				Q102 8-729-200-17 TRANSISTOR 2SA1091-O	
		D203 8-719-051-85 DIODE HSS83TD				Q201 8-729-041-66 TRANSISTOR 2SC4015TV2	
		D204 8-719-051-85 DIODE HSS83TD				Q202 8-729-200-17 TRANSISTOR 2SA1091-O	
		D205 8-719-052-12 DIODE 1SS376TE-17				Q301 8-729-041-66 TRANSISTOR 2SC4015TV2	
		D206 8-719-404-50 DIODE MA111-TX				Q302 8-729-200-17 TRANSISTOR 2SA1091-O	
		D211 8-719-062-51 DIODE 1PS226-115				Q401 8-729-901-00 TRANSISTOR DTC124EK	
		D301 8-719-062-51 DIODE 1PS226-115				Q402 8-729-120-28 TRANSISTOR 2SC1623-L5L6	
		D303 8-719-051-85 DIODE HSS83TD				Q404 8-729-207-72 TRANSISTOR 2SA1037K-T-146-QR	
		D304 8-719-051-85 DIODE HSS83TD				Q405 8-729-120-28 TRANSISTOR 2SC1623-L5L6	
		D305 8-719-052-12 DIODE 1SS376TE-17				Q406 8-729-207-72 TRANSISTOR 2SA1037K-T-146-QR	
		D306 8-719-404-50 DIODE MA111-TX				Q409 8-729-207-72 TRANSISTOR 2SA1037K-T-146-QR	
		D311 8-719-062-51 DIODE 1PS226-115				Q410 8-729-032-61 TRANSISTOR 2SC5022-02	
		D401 8-719-109-85 ZENER DIODE RD5.1ESB2				<RESISTOR>	
		D402 8-719-404-50 DIODE MA111-TX				R101 1-215-395-00 METAL 82 1% 1/4W	
		D406 8-719-911-19 DIODE 1SS119-25				R103 1-216-049-00 RES,CHIP 1K 5% 1/10W	
		D413 8-719-911-19 DIODE 1SS119-25				R104 1-216-121-91 RES,CHIP 1M 5% 1/10W	
		D414 8-719-109-66 ZENER DIODE RD3.3ESB2				R105 1-216-001-00 RES,CHIP 10 5% 1/10W	
		D415 8-719-051-85 DIODE HSS83TD				R106 1-216-019-00 RES,CHIP 56 5% 1/10W	
		<FERRITE BEAD>				R107 1-216-129-00 RES,CHIP 2.2M 5% 1/10W	
		FB101 1-500-419-21 FERRITE				R108 1-219-742-11 CARBON 47 5% 1/2W	
		FB201 1-500-419-21 FERRITE				R109 1-216-039-00 RES,CHIP 390 5% 1/10W	
		FB301 1-500-419-21 FERRITE				R110 1-216-689-11 RES,CHIP 39K 5% 1/10W	
		FB404 1-412-911-31 FERRITE 1.1 μ H				R111 1-216-089-00 RES,CHIP 47K 5% 1/10W	
		FB405 1-412-911-31 FERRITE 1.1 μ H				R112 1-216-121-91 RES,CHIP 1M 5% 1/10W	
		FB406 1-412-911-31 FERRITE 1.1 μ H				R113 1-216-057-00 RES,CHIP 2.2K 5% 1/10W	
		FB408 1-412-911-31 FERRITE 1.1 μ H				R114 1-216-097-00 RES,CHIP 100K 5% 1/10W	
		FB414 1-412-911-31 FERRITE 1.1 μ H				R115 1-216-049-00 RES,CHIP 1K 5% 1/10W	
		<IC>				R116 1-216-097-00 RES,CHIP 100K 5% 1/10W	
		IC401 8-759-635-27 IC M62352GP-75E				R117 1-216-049-00 RES,CHIP 1K 5% 1/10W	
		IC402 8-759-925-72 IC SN74HC02ANS				R118 1-216-689-11 RES,CHIP 39K 5% 1/10W	
		IC403 8-759-445-85 IC LM1283N				R121 1-216-081-00 RES,CHIP 22K 5% 1/10W	
		IC404 8-759-566-26 IC LSC4380DW2AR2				R124 1-216-659-11 METAL CHIP 2.2K 0.50% 1/10W	
		IC405 8-759-502-82 IC LM324M				R132 1-216-129-00 RES,CHIP 2.2M 5% 1/10W	
		IC406 8-759-263-43 IC TA78M12S				R140 1-216-017-91 RES,CHIP 47 5% 1/10W	
		IC407 8-759-435-33 IC LM2405T				R141 1-216-009-91 RES,CHIP 22 5% 1/10W	
		IC408 8-759-522-86 IC M52755FP-TP				R161 1-215-395-00 METAL 82 1% 1/4W	
						R163 1-216-017-91 RES,CHIP 47 5% 1/10W	

GDM-200PS/200PST/200PST9



REF.NO.	PART NO.	DESCRIPTION	REMARK	REF.NO.	PART NO.	DESCRIPTION	REMARK
SG402	1-519-422-11	GAP, SPARK		C042	1-164-004-11	CERAMIC CHIP 0.1μF	10% 25V

	* A-1346-659-BD BOARD, COMPLETE *****			C043	1-164-004-11	CERAMIC CHIP 0.1μF	10% 25V
	1-533-223-11	HOLDER, FUSE (F601)		C044	1-164-004-11	CERAMIC CHIP 0.1μF	10% 25V
	2-371-561-00	BUSHING (P), INSULATING		C045	1-104-760-11	CERAMIC CHIP 0.047μF	10% 50V
		(IC502, IC1504)		C046	1-104-760-11	CERAMIC CHIP 0.047μF	10% 50V
	3-710-578-01	COVER, VOLUME, 6 MOLD (RV901)		C047	1-104-760-11	CERAMIC CHIP 0.047μF	10% 50V
	4-039-357-01	SCREW (3X8), (+) BV TAPPING		C048	1-163-017-00	CERAMIC CHIP 0.0047μF	10% 50V
	4-045-133-21	HOLDER (B), LED (D006, D009)		C049	1-104-760-11	CERAMIC CHIP 0.047μF	10% 50V
	* 4-049-002-01 HOLDER, LED (D003)			C050	1-137-194-81	FILM	0.47μF 5% 50V
	4-061-191-01	SHEET, INSULATE (IC502, IC1504)		C051	1-163-009-11	CERAMIC CHIP 0.001μF	10% 50V
	4-061-192-01	SHEET, INSULATE (Q906)		C052	1-126-963-11	ELECT	4.7μF 20% 50V
	4-382-854-11	SCREW (M3X10), P, SW (+)		C053	1-126-960-11	ELECT	1μF 20% 50V
		(IC502, IC603, IC1504, Q514, Q519, Q905, Q906, D511, D601, D603, D617, R539, R919)		C054	1-164-232-11	CERAMIC CHIP 0.01μF	10% 50V
	4-812-134-00	RIVET (DIA. 3.5), NYLON		C055	1-126-964-11	ELECT	10μF 20% 50V
	<CAPACITOR>			C056	1-126-964-11	ELECT	10μF 20% 50V
C001	1-163-009-11	CERAMIC CHIP 0.001μF	10% 50V	C057	1-164-232-11	CERAMIC CHIP 0.01μF	10% 50V
C002	1-163-009-11	CERAMIC CHIP 0.001μF	10% 50V	C058	1-163-243-11	CERAMIC CHIP 47pF	5% 50V
C003	1-164-004-11	CERAMIC CHIP 0.1μF	10% 25V	C059	1-163-257-11	CERAMIC CHIP 180pF	5% 50V
C004	1-104-664-11	ELECT	47μF 20% 25V	C060	1-126-964-11	ELECT	10μF 20% 50V
C005	1-164-004-11	CERAMIC CHIP 0.1μF	10% 25V	C061	1-104-760-11	CERAMIC CHIP 0.047μF	10% 50V
C006	1-164-004-11	CERAMIC CHIP 0.1μF	10% 25V	C062	1-104-760-11	CERAMIC CHIP 0.047μF	10% 50V
C007	1-164-232-11	CERAMIC CHIP 0.01μF	10% 50V	C063	1-164-232-11	CERAMIC CHIP 0.01μF	10% 50V
C008	1-164-004-11	CERAMIC CHIP 0.1μF	10% 25V	C064	1-163-037-11	CERAMIC CHIP 0.022μF	10% 50V
C009	1-164-004-11	CERAMIC CHIP 0.1μF	10% 25V	C065	1-164-232-11	CERAMIC CHIP 0.01μF	10% 50V
C010	1-163-237-11	CERAMIC CHIP 27pF	5% 50V	C066	1-163-017-00	CERAMIC CHIP 0.0047μF	10% 50V
C011	1-163-237-11	CERAMIC CHIP 27pF	5% 50V	C067	1-126-964-11	ELECT	10μF 20% 50V
C012	1-163-009-11	CERAMIC CHIP 0.001μF	10% 50V	C069	1-164-004-11	CERAMIC CHIP 0.1μF	10% 25V
C013	1-104-664-11	ELECT	47μF 20% 25V	C070	1-130-495-00	FILM	0.1μF 5% 50V
C014	1-164-004-11	CERAMIC CHIP 0.1μF	10% 25V	C071	1-126-960-11	ELECT	1μF 20% 50V
C015	1-163-009-11	CERAMIC CHIP 0.001μF	10% 50V	C072	1-130-495-00	FILM	0.1μF 5% 50V
C016	1-104-664-11	ELECT	47μF 20% 25V	C073	1-126-964-11	ELECT	10μF 20% 50V
C017	1-164-232-11	CERAMIC CHIP 0.01μF	10% 50V	C074	1-164-232-11	CERAMIC CHIP 0.01μF	10% 50V
C021	1-164-232-11	CERAMIC CHIP 0.01μF	10% 50V	C075	1-104-665-11	ELECT	100μF 20% 25V
C022	1-164-232-11	CERAMIC CHIP 0.01μF	10% 50V	C076	1-164-232-11	CERAMIC CHIP 0.01μF	10% 50V
C023	1-164-004-11	CERAMIC CHIP 0.1μF	10% 25V	C077	1-126-791-11	ELECT	10μF 20% 16V
C024	1-104-664-11	ELECT	47μF 20% 25V	C078	1-164-004-11	CERAMIC CHIP 0.1μF	10% 25V
C025	1-104-664-11	ELECT	47μF 20% 25V	C079	1-164-004-11	CERAMIC CHIP 0.1μF	10% 25V
C026	1-163-275-11	CERAMIC CHIP 0.001μF	5% 50V	C081	1-164-232-11	CERAMIC CHIP 0.01μF	10% 50V
C027	1-126-961-11	ELECT	2.2μF 20% 50V	C083	1-104-664-11	ELECT	47μF 20% 25V
C028	1-104-664-11	ELECT	47μF 20% 25V	C084	1-163-243-11	CERAMIC CHIP 47pF	5% 50V
C029	1-126-935-11	ELECT	470μF 20% 16V	C085	1-163-243-11	CERAMIC CHIP 47pF	5% 50V
C030	1-137-372-11	FILM	0.022μF 5% 50V	C086	1-164-004-11	CERAMIC CHIP 0.1μF	10% 25V
C031	1-164-004-11	CERAMIC CHIP 0.1μF	10% 25V	C087	1-164-004-11	CERAMIC CHIP 0.1μF	10% 25V
C032	1-163-231-11	CERAMIC CHIP 15pF	5% 50V	C088	1-164-232-11	CERAMIC CHIP 0.01μF	10% 50V
C036	1-164-232-11	CERAMIC CHIP 0.01μF	10% 50V	C501	1-163-005-11	CERAMIC CHIP 470pF	10% 50V
C037	1-164-690-91	CERAMIC CHIP 0.0022μF	5% 50V	C502	1-163-259-91	CERAMIC CHIP 220pF	5% 50V
C038	1-126-960-11	ELECT	1μF 20% 50V	C503	1-126-967-11	ELECT	47μF 20% 50V
C040	1-163-137-00	CERAMIC CHIP 680pF	5% 50V	C504	1-137-194-81	FILM	0.47μF 5% 50V
C041	1-164-004-11	CERAMIC CHIP 0.1μF	10% 25V	C505	1-163-009-11	CERAMIC CHIP 0.001μF	10% 50V
				C506	1-164-004-11	CERAMIC CHIP 0.1μF	10% 25V
				C507	1-163-037-11	CERAMIC CHIP 0.022μF	10% 50V
				C509	1-104-664-11	ELECT	47μF 20% 25V
				C510	1-126-941-11	ELECT	470μF 20% 25V
				C511	1-164-004-11	CERAMIC CHIP 0.1μF	10% 25V
				C512	1-110-641-51	ELECT	33μF 20% 200V
				C514	1-164-281-11	CERAMIC	0.001μF 2KV

The components identified by shading and mark Δ are critical for safety. Replace only with part number specified.

Les composants identifiés par un trame et une marque Δ sont critiques pour la sécurité. Ne les remplacer que par une pièce portant le numéro spécifié.



REF.NO.	PART NO.	DESCRIPTION	REMARK	REF.NO.	PART NO.	DESCRIPTION	REMARK
C515	1-106-383-00	MYLAR	0.047 μ F 10% 200V	C607	1-137-479-11	FILM	1 μ F 10% 400V
C517	1-137-368-11	FILM	0.0047 μ F 5% 50V	C608	1-117-849-11	ELECT	330 μ F 20% 450V
C518	1-137-368-11	FILM	0.0047 μ F 5% 50V	C609	1-117-971-51	MYLAR	1 μ F 10% 400V
C520	1-104-664-11	ELECT	47 μ F 20% 25V	C610	1-164-004-11	CERAMIC CHIP	0.1 μ F 10% 25V
C521	1-164-161-11	CERAMIC CHIP	0.0022 μ F 10% 50V	C611	1-126-964-11	ELECT	10 μ F 20% 50V
C522	1-126-963-11	ELECT	4.7 μ F 20% 50V	C612	1-125-969-91	CERAMIC	680pF 10% 1KV
C523	1-117-955-11	FILM	0.17 μ F 5% 400V	C613	1-126-963-11	ELECT	4.7 μ F 20% 50V
C524	1-163-009-11	CERAMIC CHIP	0.001 μ F 10% 50V	C614	1-104-664-11	ELECT	47 μ F 20% 25V
C525	1-128-562-11	ELECT	47 μ F 20% 100V	C615	1-119-575-11	FILM	0.03 μ F 3% 1KV
C526	1-128-561-91	ELECT	33 μ F 20% 100V	C616	1-130-495-00	FILM	0.1 μ F 5% 50V
C529	1-164-232-11	CERAMIC CHIP	0.01 μ F 10% 50V	C617	1-104-665-11	ELECT	100 μ F 20% 10V
C530	1-163-017-00	CERAMIC CHIP	0.0047 μ F 10% 50V	C618	1-130-029-00	FILM	8200pF 2% 50V
C531	1-164-004-11	CERAMIC CHIP	0.1 μ F 10% 25V	C619	1-125-969-91	CERAMIC	680pF 10% 1KV
C532	1-115-519-11	FILM	0.56 μ F 5% 250V	C620	1-111-082-11	ELECT	100 μ F 20% 35V
C533	1-115-515-11	FILM	0.27 μ F 5% 250V	C621	1-126-963-11	ELECT	4.7 μ F 20% 50V
C536	1-164-232-11	CERAMIC CHIP	0.01 μ F 10% 50V	C622	1-126-964-11	ELECT	10 μ F 20% 50V
C538	1-117-954-11	FILM	4300pF 3% 1.8KV	C623	1-119-769-11	FILM	0.018 μ F 3% 1KV
C539	1-163-009-11	CERAMIC CHIP	0.001 μ F 10% 50V	C624	1-111-019-51	ELECT	0.0022F 20% 10V
C540	1-163-017-00	CERAMIC CHIP	0.0047 μ F 10% 50V	C625	1-107-906-11	ELECT	10 μ F 20% 50V
C541	1-164-232-11	CERAMIC CHIP	0.01 μ F 10% 50V	C626	1-137-370-11	FILM	0.01 μ F 5% 50V
C542	1-136-553-11	FILM	0.0015 μ F 5% 630V	C627	1-128-563-11	ELECT	100 μ F 20% 100V
C543	1-162-558-11	CERAMIC	100pF 10% 2KV	C628	1-126-927-11	ELECT	2200 μ F 20% 10V
C544	1-163-017-00	CERAMIC CHIP	0.0047 μ F 10% 50V	C629	1-126-927-11	ELECT	2200 μ F 20% 10V
C545	1-115-512-11	FILM	0.15 μ F 5% 250	C630	1-128-564-11	ELECT	220 μ F 20% 100V
C546	1-107-599-11	CERAMIC	27pF 5% 500V	C631	1-126-943-11	ELECT	2200 μ F 20% 25V
C547	1-164-232-11	CERAMIC CHIP	0.01 μ F 10% 50V	C632	1-126-943-11	ELECT	2200 μ F 20% 25V
C548	1-115-509-11	FILM	0.068 μ F 5% 250V	C634	1-107-950-11	ELECT	3.3 μ F 20% 200V
C549	1-130-495-00	FILM	0.1 μ F 5% 50V	C635	1-128-581-11	ELECT	4.7 μ F 20% 100V
C550	1-164-232-11	CERAMIC CHIP	0.01 μ F 10% 50V	C636	1-107-888-11	ELECT	47 μ F 20% 25V
C551	1-162-558-11	CERAMIC	100pF 10% 2KV	C637	1-107-888-11	ELECT	47 μ F 20% 25V
C552	1-164-232-11	CERAMIC CHIP	0.01 μ F 10% 50V	C638	1-104-664-11	ELECT	47 μ F 20% 25V
C553	1-117-953-11	FILM	0.033 μ F 5% 400V	C639	1-107-888-11	ELECT	47 μ F 20% 25V
C554	1-117-450-11	FILM	0.47 μ F 10% 250V	C640	1-137-370-11	FILM	0.01 μ F 5% 50V
C555	1-162-134-11	CERAMIC	470pF 10% 2KV	C641	1-107-888-11	ELECT	47 μ F 20% 25V
C556	1-115-522-11	FILM	1 μ F 5% 250V	C642	1-107-888-11	ELECT	47 μ F 20% 25V
C557	1-119-872-91	ELECT	1 μ F 20% 200V	C643	1-128-564-11	ELECT	220 μ F 20% 100V
C558	1-164-004-11	CERAMIC CHIP	0.1 μ F 10% 25V	C644	1-119-769-11	FILM	0.018 μ F 3% 1KV
C559	1-164-281-11	CERAMIC	0.001 μ F 2KV	C645	1-102-112-00	CERAMIC	330pF 10% 50V
C560	1-163-019-00	CERAMIC CHIP	0.0068 μ F 10% 50V	C647	1-130-495-00	FILM	0.1 μ F 5% 50V
C561	1-104-664-11	ELECT	47 μ F 20% 25V	C648	1-137-370-11	FILM	0.01 μ F 5% 50V
C562	1-164-281-11	CERAMIC	0.001 μ F 2KV	C901	1-126-961-11	ELECT	2.2 μ F 20% 50V
C564	1-126-960-11	ELECT	1 μ F 20% 50V	C902	1-164-004-11	CERAMIC CHIP	0.1 μ F 10% 25V
C565	1-163-251-11	CERAMIC CHIP	100pF 5% 50V	C903	1-164-004-11	CERAMIC CHIP	0.1 μ F 10% 25V
C566	1-106-383-00	MYLAR	0.047 μ F 10% 200V	C904	1-163-243-11	CERAMIC CHIP	47pF 5% 50V
C567	1-163-009-11	CERAMIC CHIP	0.001 μ F 10% 50V	C905	1-163-145-00	CERAMIC CHIP	0.0015 μ F 5% 50V
C568	1-164-161-11	CERAMIC CHIP	0.0022 μ F 10% 50V	C906	1-164-232-11	CERAMIC CHIP	0.01 μ F 10% 50V
C569	1-107-597-11	CERAMIC	22pF 5% 500V	C907	1-163-275-11	CERAMIC CHIP	0.001 μ F 5% 50V
C570	1-113-481-11	FILM	1000pF 5% 630V	C908	1-163-017-00	CERAMIC CHIP	0.0047 μ F 10% 50V
C571	1-164-004-11	CERAMIC CHIP	0.1 μ F 10% 25V	C909	1-164-004-11	CERAMIC CHIP	0.1 μ F 10% 25V
C601 Δ	1-117-697-51	CERAMIC	470pF 10% 250V	C910	1-126-934-11	ELECT	220 μ F 20% 16V
C602 Δ	1-113-513-11	FILM	1 μ F 20% 250V	C911	1-163-259-91	CERAMIC CHIP	220pF 5% 50V
C603 Δ	1-115-166-11	FILM	0.22 μ F 20% 250V	C912	1-106-383-00	MYLAR	0.047 μ F 10% 200V
C604 Δ	1-113-942-91	CERAMIC	0.0047 μ F 250V	C913	1-126-967-11	ELECT	47 μ F 20% 50V
C605 Δ	1-117-697-51	CERAMIC	470pF 10% 250V	C914	1-104-760-11	CERAMIC CHIP	0.047 μ F 10% 50V
C606 Δ	1-113-942-91	CERAMIC	0.0047 μ F 250V	C915	1-110-641-51	ELECT	33 μ F 20% 200V
				C917	1-163-009-11	CERAMIC CHIP	0.001 μ F 10% 50V

GDM-200PS/200PST/200PST9



Les composants identifiés par un tramé et une marque Δ sont critiques pour la sécurité. Ne les remplacer que par une pièce portant le numéro spécifié.

The components identified by shading and mark Δ are critical for safety. Replace only with part number specified.

REF.NO.	PART NO.	DESCRIPTION	REMARK	REF.NO.	PART NO.	DESCRIPTION	REMARK
C918	1-164-004-11	CERAMIC CHIP 0.1 μ F	10% 25V	D014	8-719-404-50	DIODE MA111-TX	
C919	1-137-368-11	FILM 0.0047 μ F	5% 50V	D017	8-719-404-50	DIODE MA111-TX	
C920	1-117-626-31	FILM 2000pF	3% 1.2KV	D018	8-719-109-85	ZENER DIODE RD5.1ESB2	
C921	1-137-372-11	FILM 0.022 μ F	5% 50V	D020	8-719-062-51	DIODE 1PS226-115	
C922	1-106-228-00	MYLAR 0.22 μ F	10% 100V	D021	8-719-062-51	DIODE 1PS226-115	
C923	1-106-220-00	MYLAR 0.1 μ F	10% 100V	D022	8-719-062-51	DIODE 1PS226-115	
C924	1-106-355-12	MYLAR 0.0033 μ F	10% 200V	D023	8-719-062-51	DIODE 1PS226-115	
C925	1-106-220-00	MYLAR 0.1 μ F	10% 100V	D024	8-719-109-96	ZENER DIODE RD6.8ESB1	
C926	1-115-516-11	FILM 0.33 μ F	5% 250V	D028	8-719-109-85	ZENER DIODE RD5.1ESB2	
C927	1-163-009-11	CERAMIC CHIP 0.001 μ F	10% 50V	D030	8-719-801-78	DIODE 1SS184	
C928	1-104-665-11	ELECT 100 μ F	20% 25V	D503	8-719-911-19	DIODE 1SS119-25	
C929	1-106-383-00	MYLAR 0.047 μ F	10% 200V	D504	8-719-404-50	DIODE MA111-TX	
C931	1-126-964-11	ELECT 10 μ F	20% 50V	D505	8-719-110-02	ZENER DIODE RD7.5ESB1	
C932	1-164-004-11	CERAMIC CHIP 0.1 μ F	10% 25V	D506	8-719-977-40	ZENER DIODE DTZ13B	
C933	1-164-004-11	CERAMIC CHIP 0.1 μ F	10% 25V	D507	8-719-404-50	DIODE MA111-TX	
C935	1-164-004-11	CERAMIC CHIP 0.1 μ F	10% 25V	D508	8-719-052-86	DIODE D2L40-TA	
C936	1-126-967-11	ELECT 47 μ F	20% 50V	D509	8-719-404-50	DIODE MA111-TX	
C1501	1-164-004-11	CERAMIC CHIP 0.1 μ F	10% 25V	D510	8-719-975-77	DIODE SB340	
C1502	1-130-495-00	FILM 0.1 μ F	5% 50V	D511	8-719-061-21	DIODE FMQ-G5FMS	
C1503	1-164-004-11	CERAMIC CHIP 0.1 μ F	10% 25V	D512	8-719-109-85	ZENER DIODE RD5.1ESB2	
C1504	1-164-161-11	CERAMIC CHIP 0.0022 μ F	10% 50V	D513	8-719-109-85	ZENER DIODE RD5.1ESB2	
C1505	1-163-003-11	CERAMIC CHIP 330pF	10% 50V	D514	8-719-911-19	DIODE 1SS119-25	
C1506	1-104-664-11	ELECT 47 μ F	20% 25V	D515	8-719-911-19	DIODE 1SS119-25	
C1507	1-164-004-11	CERAMIC CHIP 0.1 μ F	10% 25V	D516	8-719-028-72	DIODE RGP02-17EL-6433	
C1508	1-130-495-00	FILM 0.1 μ F	5% 50V	D517	8-719-951-30	DIODE ERA91-02	
C1509	1-104-664-11	ELECT 47 μ F	20% 25V	D518	8-719-404-50	DIODE MA111-TX	
C1513	1-163-251-11	CERAMIC CHIP 100pF	5% 50V	D519	8-719-911-19	DIODE 1SS119-25	
C1514	1-107-914-11	ELECT 1000 μ F	20% 25V	D520	8-719-948-45	DIODE ERA22-08	
C1515	1-163-809-11	CERAMIC CHIP 0.047 μ F	10% 25V	D522	8-719-911-19	DIODE 1SS119-25	
C1516	1-164-004-11	CERAMIC CHIP 0.1 μ F	10% 25V	D523	8-719-911-19	DIODE 1SS119-25	
C1517	1-107-894-11	ELECT 220 μ F	20% 35V	D524	8-719-028-72	DIODE RGP02-17EL-6433	
C1518	1-107-914-11	ELECT 1000 μ F	20% 25V	D525	8-719-109-93	ZENER DIODE RD6.2ESB2	
C1519	1-106-228-00	MYLAR 0.22 μ F	10% 100V	D601 Δ	8-719-510-53	DIODE D4SB60L	
<CONNECTOR>				D602	8-719-911-19	DIODE 1SS119-25	
CN501*1-508-879-11	BASE POST			D603	8-719-029-04	DIODE D5L60	
CN502*1-564-515-11	PLUG, CONNECTOR 12P			D604	8-719-510-02	DIODE D1NS4	
CN503*1-564-595-11	PLUG, CONNECTOR 14P			D606	8-719-979-64	DIODE UF4005PKG23	
CN504*1-564-510-11	PLUG, CONNECTOR 7P			D607	8-719-110-31	ZENER DIODE RD12ESB2	
CN505	1-764-101-11 PIN, CONNECTOR (PC BOARD) 2P			D608	8-719-911-19	DIODE 1SS119-25	
CN506*1-779-465-11	PIN, CONNECTOR (WITH PWB) 6P			D609	8-719-302-43	DIODE EL1Z	
CN507*1-564-509-11	PLUG, CONNECTOR 6P			D610	8-719-947-06	DIODE RGP10JPKG23	
CN601*1-691-960-11	PIN, CONNECTOR (PC BOARD) 3P			D611	8-719-066-51	DIODE P6KE170AG23	
CN602*1-784-222-11	PIN, CONNECTOR (WITH PWB)			D612	8-719-028-45	DIODE D2L20U	
<DIODE>				D613	8-719-022-97	DIODE D2S4MF	
D001	8-719-109-85	ZENER DIODE RD5.1ESB2		D614	8-719-510-64	DIODE S2LA20F	
D003	8-719-045-19	DIODE SPB-26MVWF		D615	8-719-052-86	DIODE D2L40-TA	
D005	8-719-109-85	ZENER DIODE RD5.1ESB2		D616	8-719-052-86	DIODE D2L40-TA	
D006	8-719-311-90	DIODE SEL1922D-C		D617	8-719-052-91	DIODE D4SBS4-F	
D009	8-719-311-90	DIODE SEL1922D-C		D619	8-719-022-97	DIODE D2S4MF	
D010	8-719-109-85	ZENER DIODE RD5.1ESB2		D620	8-719-110-63	ZENER DIODE RD24ESB3	
D011	8-719-976-99	ZENER DIODE DTZ5.1B		D621	8-719-911-19	DIODE 1SS119-25	
D012	8-719-976-99	ZENER DIODE DTZ5.1B		D622	8-719-110-31	ZENER DIODE RD12ESB2	
D013	8-719-106-23	ZENER DIODE RD7.5M-B2		D623	8-719-404-50	DIODE MA111-TX	
				D624	8-719-977-28	ZENER DIODE DTZ10B	
				D902	8-719-158-49	ZENER DIODE RD12SB2	
				D903	8-719-404-50	DIODE MA111-TX	

The components identified by shading
and mark \triangle are critical for safety.
Replace only with part number specified.

Les composants identifiés par un trame
et une marque \triangle sont critiques pour la
sécurité. Ne les remplacer que par une
pièce portant le numéro spécifié.



REF.NO.	PART NO.	DESCRIPTION	REMARK	REF.NO.	PART NO.	DESCRIPTION	REMARK
D906	8-719-404-50	DIODE MA111-TX		IC1502	8-759-822-38	IC LA6510	
D907	8-719-404-50	DIODE MA111-TX		IC1504	8-759-980-58	IC TDA8172	
D908	8-719-404-50	DIODE MA111-TX					
D909	8-719-109-85	ZENER DIODE RD5.1ESB2					
D910	8-719-110-36	ZENER DIODE RD13ESB2				<COIL>	
D912	8-719-110-46	ZENER DIODE RD16ESB3		L001	1-412-537-31	INDUCTOR	100 μ H
D913	8-719-979-58	DIODE EGP10D		L002	1-412-549-11	INDUCTOR	1mH
D914	8-719-110-46	ZENER DIODE RD16ESB3		L003	1-410-521-11	INDUCTOR	100 μ H
D915	8-719-911-19	DIODE 1SS119-25		L501	1-412-537-31	INDUCTOR	100 μ H
D916	8-719-056-95	ZENER DIODE UDZ-TE-17-22B		L502	1-406-675-11	INDUCTOR	4.7mH
D917	8-719-052-86	DIODE D2L40-TA		L503	1-406-675-11	INDUCTOR	4.7mH
D918	8-719-158-49	ZENER DIODE RD12SB2		L504	1-416-398-11	COIL, HORIZONTAL LINEARITY	
D919	8-719-109-85	ZENER DIODE RD5.1ESB2		L505	1-406-675-11	INDUCTOR	4.7mH
D1501	8-719-109-85	ZENER DIODE RD5.1ESB2		L506	1-406-972-11	INDUCTOR	15 μ H
D1502	8-719-109-85	ZENER DIODE RD5.1ESB2		L602	1-412-537-31	INDUCTOR	100 μ H
D1503	8-719-911-19	DIODE 1SS119-25		L603	1-412-529-11	INDUCTOR	22 μ H
D1504	8-719-908-03	DIODE GP08D		L604	1-412-529-11	INDUCTOR	22 μ H
D1505	8-719-908-03	DIODE GP08D		L605	1-412-529-11	INDUCTOR	22 μ H
D1506	8-719-908-03	DIODE GP08D		L606	1-412-529-11	INDUCTOR	22 μ H
		<FUSE>		L901	1-412-537-31	INDUCTOR	100 μ H
F601	\triangle 1-576-233-11	FUSE (H.B.C.) (6.3A/250V)		L902	1-406-660-41	INDUCTOR	15 μ H
		<FERRITE BEAD>				<PHOTO COUPLER>	
FB001	1-414-598-11	INDUCTOR CHIP		PH601	8-749-010-64	PHOTO COUPLER PC123F2	
FB002	1-414-598-11	INDUCTOR CHIP		PH602	8-749-010-64	PHOTO COUPLER PC123F2	
FB501	1-410-397-21	FERRITE	1.1 μ H			<IC LINK>	
FB502	1-410-397-21	FERRITE	1.1 μ H	PS501	\triangle 1-533-592-31	LINK, IC (1.6A/90V AC, 60V DC)	
FB601	1-410-396-71	FERRITE	0.45 μ H	PS601	\triangle 1-533-593-31	LINK, IC (2A/90V AC, 60V DC)	
FB602	1-410-397-21	FERRITE	1.1 μ H	PS901	\triangle 1-533-592-31	LINK, IC (1.6A/90V AC, 60V DC)	
FB901	1-410-397-21	FERRITE	1.1 μ H			<TRANSISTOR>	
		<IC>		Q001	8-729-901-00	TRANSISTOR DTC124EK	
IC001	8-759-531-24	IC MB90553PF-G-120-BND		Q002	8-729-120-28	TRANSISTOR 2SC1623-L5L6	
IC002	8-759-442-20	IC 24LC21A/SN		Q003	8-729-120-28	TRANSISTOR 2SC1623-L5L6	
IC004	8-759-454-79	IC 24LC16BT/SN		Q004	8-729-120-28	TRANSISTOR 2SC1623-L5L6	
IC005	8-759-162-80	IC MM1170BFB		Q005	8-729-901-00	TRANSISTOR DTC124EK	
IC007	8-752-078-46	IC CXA2043Q		Q007	8-729-027-31	TRANSISTOR DTA124EKA-T146	
IC008	8-759-701-59	IC NJM78M09FA		Q008	8-729-920-72	TRANSISTOR 2SA1037K-T-146-QR	
IC009	8-759-925-74	IC SN74HC04ANS		Q009	8-729-120-28	TRANSISTOR 2SC1623-L5L6	
IC010	8-752-083-83	IC CXA2044M-T6		Q010	8-729-920-72	TRANSISTOR 2SA1037K-T-146-QR	
IC011	8-759-168-20	IC TA78L09S		Q503	8-729-920-72	TRANSISTOR 2SA1037K-T-146-QR	
IC013	8-759-269-09	IC SN74HCT04ANS		Q504	8-729-120-28	TRANSISTOR 2SC1623-L5L6	
IC501	8-759-100-96	IC UPC4558G2		Q505	8-729-920-72	TRANSISTOR 2SA1037K-T-146-QR	
IC502	8-759-803-42	IC LA6500-FA		Q507	8-729-120-28	TRANSISTOR 2SC1623-L5L6	
IC601	8-749-013-76	IC PQ6RD83B		Q509	8-729-901-97	TRANSISTOR 2SA1036K-Q	
IC602	8-759-469-10	IC TOP223PF1		Q510	8-729-120-28	TRANSISTOR 2SC1623-L5L6	
IC603	8-749-013-78	IC MCR5102		Q511	8-729-031-89	TRANSISTOR 2SC3941A-Q(TA)	
IC604	8-749-012-49	IC DM-57N		Q512	8-729-807-12	TRANSISTOR 2SD1802-S	
IC605	8-759-231-53	IC TA7805S		Q514	8-729-035-54	TRANSISTOR 2SJ449	
IC901	8-759-467-70	IC BA9756FS-E2		Q516	8-729-800-32	TRANSISTOR 2SC2362K-G	
IC902	8-759-510-73	IC BA10393F-E2		Q517	8-729-140-50	TRANSISTOR 2SC3209LK	
IC1501	8-759-803-42	IC LA6500-FA					

GDM-200PS/200PST/200PST9



REF.NO.	PART NO.	DESCRIPTION	REMARK	REF.NO.	PART NO.	DESCRIPTION	REMARK
Q518	8-729-041-95	TRANSISTOR IRLI540GLF33		R039	1-216-049-00	RES,CHIP	1K 5% 1/10W
Q519	8-729-041-64	TRANSISTOR BU2527AX-ON5020		R040	1-216-037-00	RES,CHIP	330 5% 1/10W
Q520	8-729-041-93	TRANSISTOR IRLI530GLF33		R042	1-216-073-00	RES,CHIP	10K 5% 1/10W
Q521	8-729-120-28	TRANSISTOR 2SC1623-L5L6		R043	1-216-037-00	RES,CHIP	330 5% 1/10W
Q522	8-729-041-93	TRANSISTOR IRLI530GLF33		R044	1-216-295-00	SHORT	0
Q523	8-729-041-93	TRANSISTOR IRLI530GLF33		R045	1-216-295-00	SHORT	0
Q524	8-729-041-93	TRANSISTOR IRLI530GLF33		R046	1-216-295-00	SHORT	0
Q525	8-729-920-72	TRANSISTOR 2SA1037K-T-146-QR		R048	1-216-073-00	RES,CHIP	10K 5% 1/10W
Q527	8-729-033-25	TRANSISTOR DTC114GKA		R049	1-216-073-00	RES,CHIP	10K 5% 1/10W
Q528	8-729-204-91	TRANSISTOR 2SA1049-GR		R051	1-216-065-00	RES,CHIP	4.7K 5% 1/10W
Q529	8-729-178-43	TRANSISTOR 2SC2784-E		R052	1-216-025-00	RES,CHIP	100 5% 1/10W
Q530	8-729-207-89	TRANSISTOR 2SA1358-Y		R053	1-216-097-00	RES,CHIP	100K 5% 1/10W
Q531	8-729-207-82	TRANSISTOR 2SC3421-Y		R055	1-216-089-00	RES,CHIP	47K 5% 1/10W
Q532	8-729-120-28	TRANSISTOR 2SC1623-L5L6		R056	1-216-017-91	RES,CHIP	47 5% 1/10W
Q601	8-729-033-25	TRANSISTOR DTC114GKA		R057	1-216-025-00	RES,CHIP	100 5% 1/10W
Q602	8-729-029-40	TRANSISTOR DTA124ESA		R058	1-216-049-00	RES,CHIP	1K 5% 1/10W
Q603	8-729-033-25	TRANSISTOR DTC114GKA		R059	1-216-089-00	RES,CHIP	47K 5% 1/10W
Q604	8-729-033-26	TRANSISTOR DTA114GKAT146		R061	1-216-073-00	RES,CHIP	10K 5% 1/10W
Q605	8-729-119-78	TRANSISTOR 2SC2785-HFE		R062	1-216-025-00	RES,CHIP	100 5% 1/10W
Q901	8-729-120-28	TRANSISTOR 2SC1623-L5L6		R063	1-216-025-00	RES,CHIP	100 5% 1/10W
Q903	8-729-901-97	TRANSISTOR 2SA1036K-Q		R065	1-216-105-91	RES,CHIP	220K 5% 1/10W
Q904	8-729-120-28	TRANSISTOR 2SC1623-L5L6		R066	1-216-073-00	RES,CHIP	10K 5% 1/10W
Q905	8-729-035-54	TRANSISTOR 2SJ449		R067	1-216-679-11	METAL CHIP	15K 0.50%1/10W
Q906	8-729-041-94	TRANSISTOR IRFPE50L21		R068	1-216-073-00	RES,CHIP	10K 5% 1/10W
		<RESISTOR>		R069	1-216-049-00	RES,CHIP	1K 5% 1/10W
R001	1-216-057-00	RES,CHIP	2.2K 5% 1/10W	R070	1-216-061-00	RES,CHIP	3.3K 5% 1/10W
R003	1-216-057-00	RES,CHIP	2.2K 5% 1/10W	R071	1-216-295-00	SHORT	0
R005	1-216-025-00	RES,CHIP	100 5% 1/10W	R072	1-216-065-00	RES,CHIP	4.7K 5% 1/10W
R006	1-216-049-00	RES,CHIP	1K 5% 1/10W	R073	1-216-073-00	RES,CHIP	10K 5% 1/10W
R007	1-216-057-00	RES,CHIP	2.2K 5% 1/10W	R074	1-216-049-00	RES,CHIP	1K 5% 1/10W
R008	1-216-067-00	RES,CHIP	5.6K 5% 1/10W	R075	1-216-681-11	METAL CHIP	18K 0.50%1/10W
R009	1-216-049-00	RES,CHIP	1K 5% 1/10W	R076	1-216-651-11	METAL CHIP	1K 0.50%1/10W
R011	1-216-049-00	RES,CHIP	1K 5% 1/10W	R077	1-216-049-00	RES,CHIP	1K 5% 1/10W
R012	1-216-045-00	RES,CHIP	680 5% 1/10W	R078	1-216-073-00	RES,CHIP	10K 5% 1/10W
R013	1-216-057-00	RES,CHIP	2.2K 5% 1/10W	R079	1-216-049-00	RES,CHIP	1K 5% 1/10W
R015	1-216-017-91	RES,CHIP	47 5% 1/10W	R080	1-216-049-00	RES,CHIP	1K 5% 1/10W
R016	1-216-041-00	RES,CHIP	470 5% 1/10W	R081	1-216-659-11	METAL CHIP	2.2K 0.50%1/10W
R017	1-216-041-00	RES,CHIP	470 5% 1/10W	R082	1-216-073-00	RES,CHIP	10K 5% 1/10W
R018	1-216-017-91	RES,CHIP	47 5% 1/10W	R083	1-216-065-00	RES,CHIP	4.7K 5% 1/10W
R019	1-216-037-00	RES,CHIP	330 5% 1/10W	R084	1-216-073-00	RES,CHIP	10K 5% 1/10W
R020	1-216-037-00	RES,CHIP	330 5% 1/10W	R086	1-216-073-00	RES,CHIP	10K 5% 1/10W
R023	1-216-025-00	RES,CHIP	100 5% 1/10W	R087	1-216-679-11	METAL CHIP	15K 0.50%1/10W
R026	1-216-065-00	RES,CHIP	4.7K 5% 1/10W	R089	1-216-025-00	RES,CHIP	100 5% 1/10W
R027	1-216-049-00	RES,CHIP	1K 5% 1/10W	R090	1-216-025-00	RES,CHIP	100 5% 1/10W
R028	1-216-061-00	RES,CHIP	3.3K 5% 1/10W	R091	1-216-025-00	RES,CHIP	100 5% 1/10W
R029	1-216-049-00	RES,CHIP	1K 5% 1/10W	R092	1-216-025-00	RES,CHIP	100 5% 1/10W
R030	1-216-041-00	RES,CHIP	470 5% 1/10W	R093	1-216-025-00	RES,CHIP	100 5% 1/10W
R031	1-216-049-00	RES,CHIP	1K 5% 1/10W	R094	1-216-025-00	RES,CHIP	100 5% 1/10W
R032	1-216-049-00	RES,CHIP	1K 5% 1/10W	R095	1-216-025-00	RES,CHIP	100 5% 1/10W
R033	1-216-037-00	RES,CHIP	330 5% 1/10W	R096	1-216-025-00	RES,CHIP	100 5% 1/10W
R034	1-216-049-00	RES,CHIP	1K 5% 1/10W	R098	1-216-671-11	METAL CHIP	6.8K 0.50%1/10W
R035	1-216-671-11	METAL CHIP	6.8K 0.50%1/10W	R099	1-216-065-00	RES,CHIP	4.7K 5% 1/10W
R036	1-216-073-00	RES,CHIP	10K 5% 1/10W	R501	1-216-097-00	RES,CHIP	100K 5% 1/10W
R037	1-216-049-00	RES,CHIP	1K 5% 1/10W	R502	1-216-049-00	RES,CHIP	1K 5% 1/10W
R038	1-216-049-00	RES,CHIP	1K 5% 1/10W	R503	1-216-097-00	RES,CHIP	100K 5% 1/10W

The components identified by shading and mark Δ are critical for safety. Replace only with part number specified.

Les composants identifiés par un trame Δ sont critiques pour la sécurité. Ne les remplacer que par une pièce portant le numéro spécifié.



REF.NO.	PART NO.	DESCRIPTION	REMARK	REF.NO.	PART NO.	DESCRIPTION	REMARK
R504	1-216-073-00	RES,CHIP	10K 5% 1/10W	R560	1-260-096-11	CARBON	560 5% 1/2W
R505	1-216-081-00	RES,CHIP	22K 5% 1/10W	R561	1-249-413-11	CARBON	470 5% 1/4W F
R506	1-216-033-00	RES,CHIP	220 5% 1/10W	R562	1-260-320-11	CARBON	220 5% 1/2W
R507	1-216-093-91	RES,CHIP	68K 5% 1/10W	R563	1-215-886-11	METAL OXIDE	100 5% 2W F
R508	1-216-073-00	RES,CHIP	10K 5% 1/10W	R564	1-216-057-00	RES,CHIP	2.2K 5% 1/10W
R509	1-216-057-00	RES,CHIP	2.2K 5% 1/10W	R565	1-216-079-00	RES,CHIP	18K 5% 1/10W
R510	1-216-033-00	RES,CHIP	220 5% 1/10W	R566	1-260-316-51	CARBON	100 5% 1/2W
R511	1-216-025-00	RES,CHIP	100 5% 1/10W	R567	1-249-403-11	CARBON	68 5% 1/4W
R512	1-219-755-11	CARBON	10M 5% 1/2W	R568	1-214-840-00	METAL	100 1% 1/2W
R513	1-216-097-00	RES,CHIP	100K 5% 1/10W	R569	1-216-073-00	RES,CHIP	10K 5% 1/10W
R514	1-216-057-00	RES,CHIP	2.2K 5% 1/10W	R570	1-260-344-11	CARBON	22K 5% 1/2W
R515	1-216-683-11	METAL CHIP	22K 0.50%1/10W	R571	1-216-081-00	RES,CHIP	22K 5% 1/10W
R516	1-216-683-11	METAL CHIP	22K 0.50%1/10W	R572	1-249-437-11	CARBON	47K 5% 1/4W
R517	1-249-397-11	CARBON	22 5% 1/4W F	R573	1-249-437-11	CARBON	47K 5% 1/4W
R518	1-216-073-00	RES,CHIP	10K 5% 1/10W	R574	1-249-437-11	CARBON	47K 5% 1/4W
R519	1-216-065-00	RES,CHIP	4.7K 5% 1/10W	R575	1-249-437-11	CARBON	47K 5% 1/4W
R520	1-216-097-00	RES,CHIP	100K 5% 1/10W	R576	1-249-437-11	CARBON	47K 5% 1/4W
R521	1-219-510-11	CARBON	470K 5% 1/2W	R577	1-249-389-11	CARBON	4.7 5% 1/4W F
R522	1-216-065-00	RES,CHIP	4.7K 5% 1/10W	R578	1-216-655-11	METAL CHIP	1.5K 0.50%1/10W
R523	1-216-097-00	RES,CHIP	100K 5% 1/10W	R579	1-216-081-00	RES,CHIP	22K 5% 1/10W
R524	1-216-635-11	METAL CHIP	220 0.50%1/10W	R580	1-249-430-11	CARBON	12K 5% 1/4W
R525	1-216-675-11	METAL CHIP	10K 0.50%1/10W	R582	1-249-413-11	CARBON	470 5% 1/4W F
R526	1-260-296-11	CARBON	2.2 5% 1/2W	R583	1-249-389-11	CARBON	4.7 5% 1/4W F
R527	1-215-860-11	METAL OXIDE	33 5% 1W F	R584	1-249-389-11	CARBON	4.7 5% 1/4W F
R528	1-216-677-11	METAL CHIP	12K 0.50%1/10W	R586	1-216-081-00	RES,CHIP	22K 5% 1/10W
R529	1-216-691-11	METAL CHIP	47K 0.50%1/10W	R587	1-216-357-00	METAL OXIDE	4.7 5% 1W F
R530	1-216-081-00	RES,CHIP	22K 5% 1/10W	R589	1-216-643-11	METAL CHIP	470 0.50%1/10W
R531	1-216-081-00	RES,CHIP	22K 5% 1/10W	R590	1-247-815-91	CARBON	220 5% 1/4W
R532	1-216-683-11	METAL CHIP	22K 0.50%1/10W	R591	1-249-393-11	CARBON	10 5% 1/4W F
R533	1-216-073-00	RES,CHIP	10K 5% 1/10W	R592	1-216-341-11	METAL OXIDE	0.22 5% 1W F
R534	1-216-683-11	METAL CHIP	22K 0.50%1/10W	R593	1-216-675-11	METAL CHIP	10K 0.50%1/10W
R535	1-216-049-00	RES,CHIP	1K 5% 1/10W	R594	1-216-689-11	METAL CHIP	39K 0.50%1/10W
R536	1-216-425-11	METAL OXIDE	56 5% 1W F	R595	1-216-065-00	RES,CHIP	4.7K 5% 1/10W
R537	1-216-081-00	RES,CHIP	22K 5% 1/10W	R596	1-216-057-00	RES,CHIP	2.2K 5% 1/10W
R538	1-216-073-00	RES,CHIP	10K 5% 1/10W	R597	1-216-643-11	METAL CHIP	470 0.50%1/10W
R539	1-219-677-11	METAL	1.8 5% 10W	R601 Δ	1-220-825-91	CARBON	330K 5% 1/2W
R540	1-216-679-11	METAL CHIP	15K 0.50%1/10W	R602	1-260-089-11	CARBON	150 5% 1/2W
R541	1-216-673-11	METAL CHIP	8.2K 0.50%1/10W	R603	1-249-403-11	CARBON	68 5% 1/4W
R542	1-216-049-00	RES,CHIP	1K 5% 1/10W	R604	1-215-432-00	METAL	3K 1% 1/4W
R543	1-249-429-11	CARBON	10K 5% 1/4W	R605	1-202-933-61	FUSIBLE	0.1 10% 1/2W F
R544	1-216-423-11	METAL OXIDE	27 5% 1W F	R606	1-249-429-11	CARBON	10K 5% 1/4W
R545	1-216-089-00	RES,CHIP	47K 5% 1/10W	R607	1-216-073-00	RES,CHIP	10K 5% 1/10W
R546	1-216-049-00	RES,CHIP	1K 5% 1/10W	R608	1-218-191-11	METAL OXIDE	0.1 5% 1W F
R547	1-216-073-00	RES,CHIP	10K 5% 1/10W	R610	1-215-429-00	METAL	2.2K 1% 1/4W
R548	1-216-673-11	METAL CHIP	8.2K 0.50%1/10W	R611	1-249-389-11	CARBON	4.7 5% 1/4W F
R549	1-216-049-00	RES,CHIP	1K 5% 1/10W	R613	1-247-791-91	CARBON	22 5% 1/4W
R550	1-216-073-00	RES,CHIP	10K 5% 1/10W	R614	1-215-861-00	METAL OXIDE	47 5% 1W F
R551	1-216-049-00	RES,CHIP	1K 5% 1/10W	R615	1-247-815-91	CARBON	220 5% 1/4W
R552	1-216-081-00	RES,CHIP	22K 5% 1/10W	R616	1-249-441-11	CARBON	100K 5% 1/4W
R553	1-216-659-11	METAL CHIP	2.2K 0.50%1/10W	R617	1-249-417-11	CARBON	1K 5% 1/4W
R554	1-249-429-11	CARBON	10K 5% 1/4W F	R618	1-249-441-11	CARBON	100K 5% 1/4W
R555	1-216-049-00	RES,CHIP	1K 5% 1/10W	R621	1-215-459-00	METAL	39K 1% 1/4W
R556	1-216-073-00	RES,CHIP	10K 5% 1/10W	R622	1-215-481-00	METAL	330K 1% 1/4W
R557	1-216-385-11	METAL OXIDE	0.47 5% 3W F	R623	1-249-417-11	CARBON	1K 5% 1/4W
R558	1-216-097-00	RES,CHIP	100K 5% 1/10W	R624	1-249-417-11	CARBON	1K 5% 1/4W
R559	1-216-049-00	RES,CHIP	1K 5% 1/10W	R625	1-249-413-11	CARBON	470 5% 1/4W F

GDM-200PS/200PST/200PST9



REF.NO.	PART NO.	DESCRIPTION	REMARK	REF.NO.	PART NO.	DESCRIPTION	REMARK
R626	1-249-417-11	CARBON	1K	5%	1/4W		
R627	1-218-191-11	METAL OXIDE	0.1	5%	1W	F	
R628	1-249-417-11	CARBON	1K	5%	1/4W		
R629	1-215-443-00	METAL	8.2K	1%	1/4W		
R630	1-249-421-11	CARBON	2.2K	5%	1/4W		
R631	1-249-429-11	CARBON	10K	5%	1/4W		
R632	1-249-429-11	CARBON	10K	5%	1/4W		
R633	1-215-477-00	METAL	220K	1%	1/4W		
R634	1-215-477-00	METAL	220K	1%	1/4W		
R635	1-215-477-00	METAL	220K	1%	1/4W		
R636	1-215-451-00	METAL	18K	1%	1/4W		
R637	1-215-421-00	METAL	1K	1%	1/4W		
R638	1-249-429-11	CARBON	10K	5%	1/4W		
R639	1-249-441-11	CARBON	100K	5%	1/4W		
R640	1-216-049-00	RES,CHIP	1K	5%	1/10W		
R641	1-249-425-11	CARBON	4.7K	5%	1/4W		
R901	1-216-065-00	RES,CHIP	4.7K	5%	1/10W		
R902	1-216-097-00	RES,CHIP	100K	5%	1/10W		
R903	1-218-762-11	METAL CHIP	270K	0.50%	1/10W		
R904	1-216-073-00	RES,CHIP	10K	5%	1/10W		
R905	1-216-061-00	RES,CHIP	3.3K	5%	1/10W		
R906	1-216-109-00	RES,CHIP	330K	5%	1/10W		
R907	1-216-065-00	RES,CHIP	4.7K	5%	1/10W		
R908	1-249-397-11	CARBON	22	5%	1/4W	F	
R909	1-216-073-00	RES,CHIP	10K	5%	1/10W		
R910	1-216-397-11	METAL OXIDE	4.7	5%	3W	F	
R911	1-216-081-00	RES,CHIP	22K	5%	1/10W		
R912	1-216-057-00	RES,CHIP	2.2K	5%	1/10W		
R913	1-216-025-00	RES,CHIP	100	5%	1/10W		
R914	1-216-073-00	RES,CHIP	10K	5%	1/10W		
R915	1-216-065-00	RES,CHIP	4.7K	5%	1/10W		
R916	1-216-033-00	RES,CHIP	220	5%	1/10W		
R917	1-249-397-11	CARBON	22	5%	1/4W	F	
R918	1-216-033-00	RES,CHIP	220	5%	1/10W		
R919	1-219-727-11	METAL	68	5%	10W		
R920	1-249-389-11	CARBON	4.7	5%	1/4W	F	
R921	1-219-748-11	CARBON	4.7K	5%	1/2W		
R922	1-216-689-11	METAL CHIP	39K	0.50%	1/10W		
R923	1-216-655-11	METAL CHIP	1.5K	0.50%	1/10W		
R924	1-220-825-11	CARBON	330K	5%	1/2W		
R925	1-216-073-00	RES,CHIP	10K	5%	1/10W		
R926	1-219-748-11	CARBON	4.7K	5%	1/2W		
R927	1-216-049-00	RES,CHIP	1K	5%	1/10W		
R928	1-216-655-11	METAL CHIP	1.5K	0.50%	1/10W		
R929	1-216-681-11	METAL CHIP	18K	0.50%	1/10W		
R930	1-216-089-00	RES,CHIP	47K	5%	1/10W		
R931	1-216-075-00	RES,CHIP	12K	5%	1/10W		
R932	1-216-089-00	RES,CHIP	47K	5%	1/10W		
R933	1-216-693-11	METAL CHIP	56K	0.50%	1/10W		
R934	1-216-655-11	METAL CHIP	1.5K	0.50%	1/10W		
R935	1-216-691-11	METAL CHIP	47K	0.50%	1/10W		
R936	1-216-073-00	RES,CHIP	10K	5%	1/10W		
R937	1-216-025-00	RES,CHIP	100	5%	1/10W		
R938	1-216-089-00	RES,CHIP	47K	5%	1/10W		
R939	1-216-033-00	RES,CHIP	220	5%	1/10W		
R940	1-216-089-00	RES,CHIP	47K	5%	1/10W		
R942	1-216-669-11	METAL CHIP	5.6K	0.50%	1/10W		
R943	1-216-065-00	RES,CHIP	4.7K	5%	1/10W		
R944	1-216-081-00	RES,CHIP	22K	5%	1/10W		
R945	1-216-081-00	RES,CHIP	22K	5%	1/10W		
R946	1-216-059-00	RES,CHIP	2.7K	5%	1/10W		
R947	1-216-675-11	METAL CHIP	10K	0.50%	1/10W		
R948	1-216-651-11	METAL CHIP	1K	0.50%	1/10W		
R951	1-216-073-00	RES,CHIP	10K	5%	1/10W		
R1001	1-216-089-00	RES,CHIP	47K	5%	1/10W		
R1002	1-216-039-00	RES,CHIP	390	5%	1/10W		
R1003	1-216-093-91	RES,CHIP	68K	5%	1/10W		
R1004	1-216-675-11	METAL CHIP	10K	0.50%	1/10W		
R1005	1-216-667-11	METAL CHIP	4.7K	0.50%	1/10W		
R1006	1-249-389-11	CARBON	4.7	5%	1/4W	F	
R1007	1-216-065-00	RES,CHIP	4.7K	5%	1/10W		
R1008	1-216-049-00	RES,CHIP	1K	5%	1/10W		
R1009	1-216-049-00	RES,CHIP	1K	5%	1/10W		
R1011	1-216-041-00	RES,CHIP	470	5%	1/10W		
R1012	1-216-025-00	RES,CHIP	100	5%	1/10W		
R1013	1-216-025-00	RES,CHIP	100	5%	1/10W		
R1021	1-216-097-00	RES,CHIP	100K	5%	1/10W		
R1022	1-216-089-00	RES,CHIP	47K	5%	1/10W		
R1024	1-216-025-00	RES,CHIP	100	5%	1/10W		
R1025	1-216-025-00	RES,CHIP	100	5%	1/10W		
R1028	1-216-065-00	RES,CHIP	4.7K	5%	1/10W		
R1029	1-216-049-00	RES,CHIP	1K	5%	1/10W		
R1030	1-216-073-00	RES,CHIP	10K	5%	1/10W		
R1031	1-216-057-00	RES,CHIP	2.2K	5%	1/10W		
R1032	1-216-057-00	RES,CHIP	2.2K	5%	1/10W		
R1035	1-216-073-00	RES,CHIP	10K	5%	1/10W		
R1501	1-216-077-00	RES,CHIP	15K	5%	1/10W		
R1502	1-216-075-00	RES,CHIP	12K	5%	1/10W		
R1503	1-216-075-00	RES,CHIP	12K	5%	1/10W		
R1504	1-216-689-11	RES,CHIP	39K	5%	1/10W		
R1505	1-249-383-11	CARBON	1.5	5%	1/4W	F	
R1506	1-216-473-11	METAL OXIDE	56	5%	3W	F	
R1507	1-249-383-11	CARBON	1.5	5%	1/4W	F	
R1508	1-216-057-00	RES,CHIP	2.2K	5%	1/10W		
R1509	1-216-298-00	RES,CHIP	2.2	5%	1/10W		
R1510	1-249-383-11	CARBON	1.5	5%	1/4W	F	
R1511	1-216-077-00	RES,CHIP	15K	5%	1/10W		
R1512	1-216-105-91	RES,CHIP	220K	5%	1/10W		
R1513	1-216-298-00	RES,CHIP	2.2	5%	1/10W		
R1514	1-249-383-11	CARBON	1.5	5%	1/4W	F	
R1515	1-216-089-00	RES,CHIP	47K	5%	1/10W		
R1516	1-215-885-00	METAL OXIDE	68	5%	2W	F	
R1517	1-216-069-00	RES,CHIP	6.8K	5%	1/10W		
R1518	1-216-077-00	RES,CHIP	15K	5%	1/10W		
R1519	1-216-073-00	RES,CHIP	10K	5%	1/10W		
R1520	1-216-097-00	RES,CHIP	100K	5%	1/10W		
R1521	1-249-383-11	CARBON	1.5	5%	1/4W	F	
R1522	1-216-083-00	RES,CHIP	27K	5%	1/10W		
R1523	1-215-886-11	METAL OXIDE	100	5%	2W	F	
R1525	1-216-077-00	RES,CHIP	15K	5%	1/10W		
R1526	1-216-651-11	METAL CHIP	1K	0.50%	1/10W		
R1527	1-216-295-00	SHORT	0				

GDM-200PS/200PST/200PST9

The components identified by shading and mark Δ are critical for safety. Replace only with part number specified.

Les composants identifiés par un tramé et une marque Δ sont critiques pour la sécurité. Ne les remplacer que par une pièce portant le numéro spécifié.

The components identified by \boxtimes in this manual have been carefully factory-selected for each set in order to satisfy regulations regarding X-ray radiation. Should replacement be required, replace only with the value originally used.



REF.NO.	PART NO.	DESCRIPTION	REMARK	REF.NO.	PART NO.	DESCRIPTION	REMARK
R1531	1-214-798-21	METAL	1.8 1% 1/2W			<SPARK GAP>	
R1532	1-216-073-00	RES,CHIP	10K 5% 1/10W	SG901	1-519-422-11	GAP, SPARK	
R1533	1-216-657-11	METAL CHIP	1.8K 0.50%1/10W	SG902	1-517-499-21	GAP, SPARK	
R1534	1-216-393-00	METAL OXIDE	2.2 5% 3W F			<TRANSFORMER>	
R1535	1-216-651-11	METAL CHIP	1K 0.50%1/10W				
R1536	1-249-413-11	CARBON	470 5% 1/4W F				
R1537	1-216-683-11	METAL CHIP	22K 0.50%1/10W	T501	1-431-056-11	TRANSFORMER, HORIZONTAL DRIVE	
R1538	1-215-866-11	METAL OXIDE	330 5% 1W F	T502	1-431-414-11	TRANSFORMER, FERRITE (DFT)	
R1539	1-249-381-11	CARBON	1 5% 1/4W F	T503	1-411-594-11	INDUCTOR 5mH	
R1540	1-216-393-00	METAL OXIDE	2.2 5% 3W F	T504	1-431-443-11	TRANSFORMER, FERRITE (HST)	
R1541	1-214-798-21	METAL	1.8 1% 1/2W	T505	1-429-301-11	TRANSFORMER, FERRITE (HCT)	
R1542	1-216-667-11	METAL CHIP	4.7K 0.50%1/10W	T601	Δ 1-429-180-11	TRANSFORMER, LINE FILTER	
		<VARIABLE RESISTOR>		T602	1-431-445-11	TRANSFORMER, CONVERTER (PFT)	
\boxtimes RV901	Δ 1-241-767-21	RES, ADJ, CERMET	100K (HV ADJ)	T603	1-431-416-11	TRANSFORMER, CONVERTER (SRT)	
		<RELAY>		T604	Δ 1-431-446-12	TRANSFORMER, CONVERTER (PIT)	
				T901	Δ X-4035-177-1	TRANSFORMER ASSY, FLYBACK	(NX-4401//J1M4)
				T902	1-411-567-11	INDUCTOR 500 μ H	
						<THERMISTOR>	
RY501	1-755-137-11	RELAY		TH501	1-807-796-11	THERMISTOR	
RY601	1-515-840-11	RELAY		TH601	Δ 1-809-260-11	THERMISTOR, POWER	
RY602	1-515-669-21	RELAY		THP601	1-809-827-11	THERMISTOR, POSITIVE	
		<SWITCH>				<VARISTOR>	
S001	1-571-532-21	SWITCH, TACTILE (CONT+)		VDR601	1-810-622-11	VARISTOR	
S002	1-571-532-21	SWITCH, TACTILE (CONT-)		VDR602	Δ 1-801-268-51	VARISTOR TNR14V471K660	
S003	1-571-532-21	SWITCH, TACTILE (OSD)				<CRYSTAL>	
S004	1-571-532-21	SWITCH, TACTILE (BRT+)		X001	1-567-781-61	VIBRATOR, CRYSTAL (4MHz)	
S005	1-571-532-21	SWITCH, TACTILE (BRT-)					
S006	1-571-532-21	SWITCH, TACTILE (INPUT)					
S007	1-571-532-21	SWITCH, TACTILE (ASC)					
S008	1-571-532-21	SWITCH, TACTILE (RESET)					
SW601	Δ 1-571-433-31	SWITCH, PUSH (AC POWER)					

