

[LEFT FFC Connector]
(60Pin Mini-LVDS)

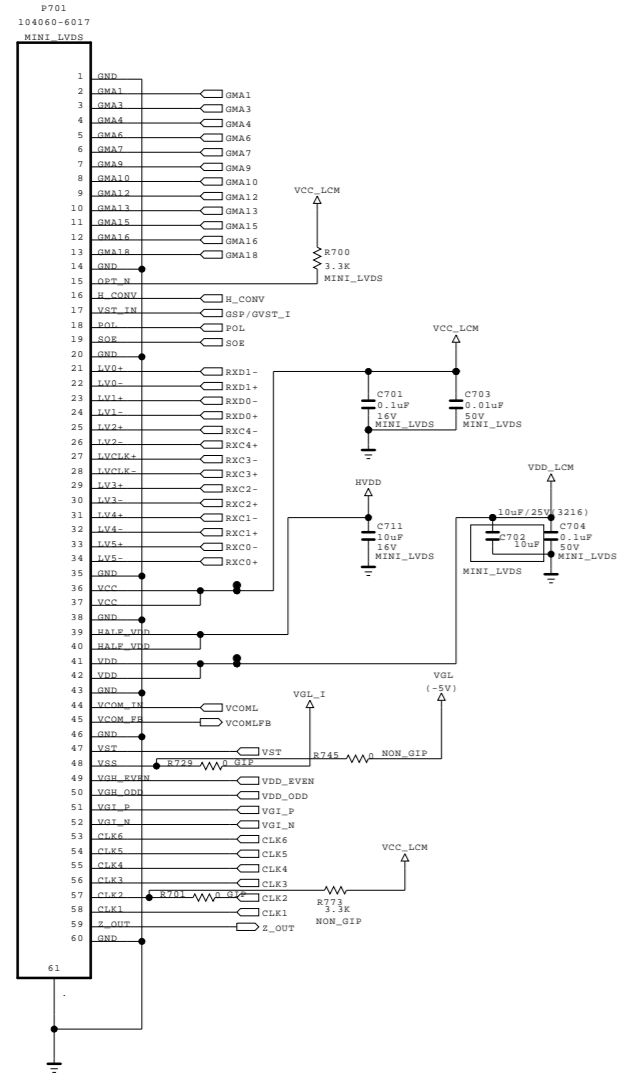

[Right FFC Connector]
(60Pin Mini-LVDS)

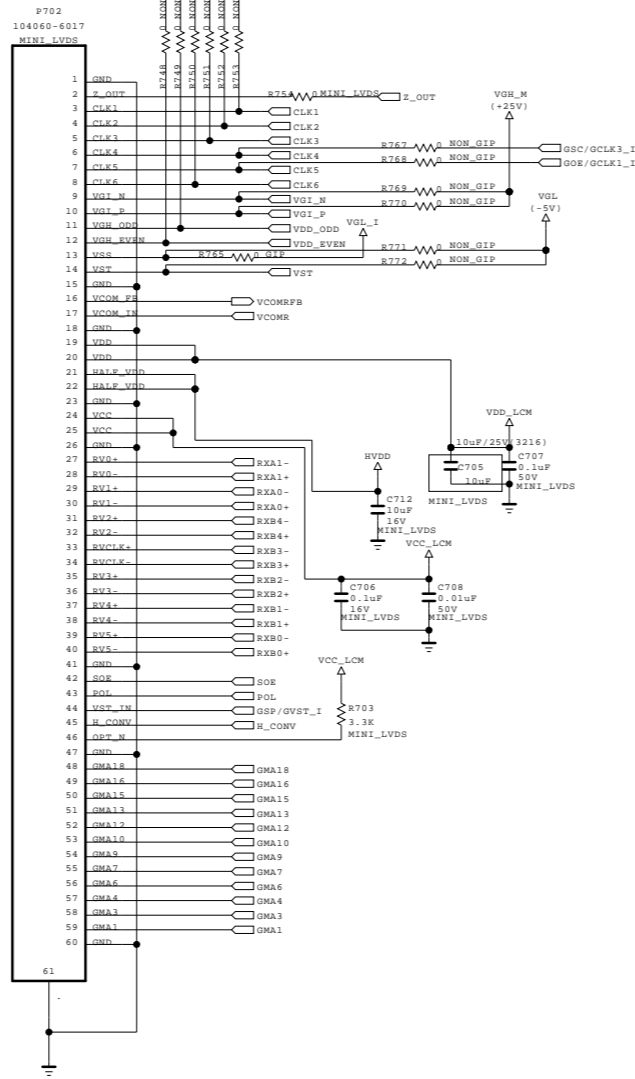

[51Pin LVDS Connector]
(For FHD 60/120Hz)

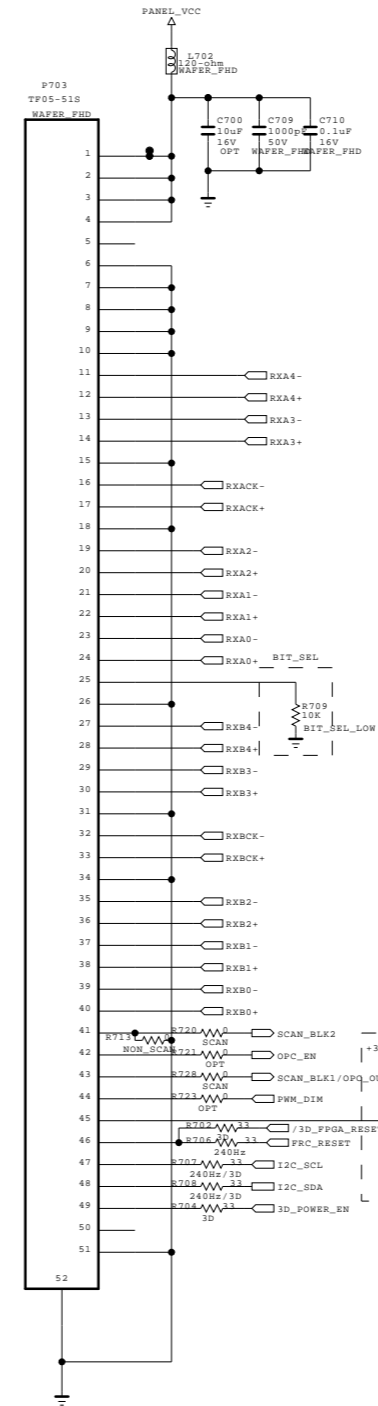

[41Pin LVDS Connector]
(For FHD 120Hz)

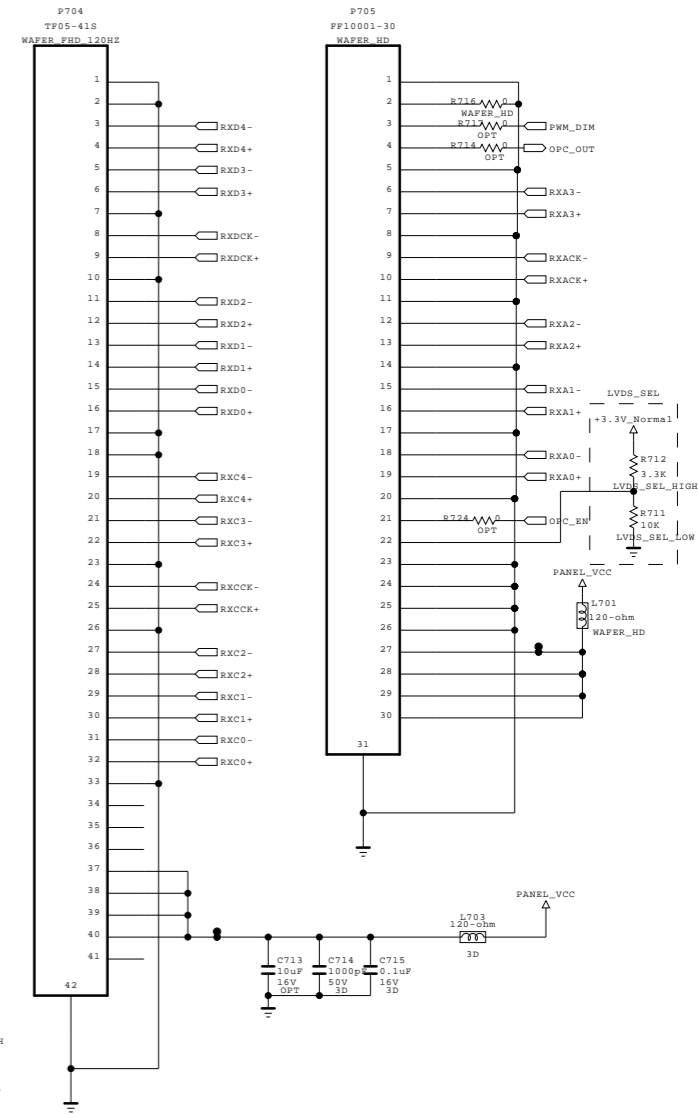

[30Pin LVDS Connector]
(For HD 60Hz_Normal)

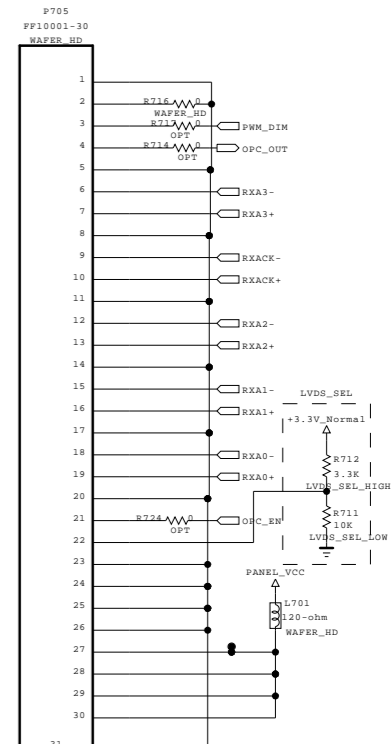

THE SYMBOL MARK OF THIS SCHEMATIC DIAGRAM INCORPORATES SPECIAL FEATURES IMPORTANT FOR PROTECTION FROM X-RADIATION. FILRE AND ELECTRICAL SHOCK HAZARDS, WHEN SERVICING IF IS ESSENTIAL THAT ONLY MANUFACTURES SPECIFIED PARTS BE USED FOR THE CRITICAL COMPONENTS IN THE SYMBOL MARK OF THE SCHEMATIC.

SECRET
LGElectronics



MODEL	GP2_Saturn7M	DATE	Ver. 1.3
BLOCK	LVDS	SHEET	36 /