

Service
Service
Service



Service Manual

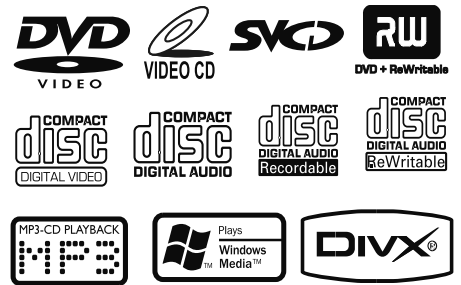

TABLE OF CONTENTS

PCBs location & Version Variations..... 1-1
 Technical specification 1-2
 Service measurement setup 1-3
 Service aids 1-4

Instructions on CD playability 2-1...2-2
 Software version check 4-1

Block diagram..... 5-1
 Wiring diagram 6-1

LCD & Key Board
 circuit diagram 7-1...7-2
 layout diagram 7-3

Rectifier Board
 circuit diagram 8-1
 layout diagram 8-1

Power AMP Board
 circuit diagram 8-3...8-4
 layout diagram 8-5

Main Board
 circuit diagram 9-1...9-5
 layout diagram 9-6...9-7

HP & AUX & USB Jack Board
 circuit diagram 9-8...9-9
 layout diagram 9-8...9-9

DVD MPEG Board
 circuit diagram 10-1...10-8
 layout diagram 10-9...10-10

Exploded view diagram 11-1
 Mechanical partslist 11-2

Electrical partslist..... 12-1...12-2
 Revision list..... 13-1

© Copyright 2010 Philips Consumer Electronics B.V. Eindhoven, The Netherlands
 All rights reserved. No part of this publication may be reproduced, stored in a retrieval system or transmitted, in any form or by any means, electronic, mechanical, photocopying, or otherwise without the prior permission of Philips.



TECHNICAL SPECIFICATIONS

AMPLIFIER

Output power 2 x 50 W RMS
 Signal-to-noise ratio ≥ 60 dBA
 Frequency response 63 – 16000 Hz, ± 3 dB
 Input sensitivity AUX 0.5 V (max. 2 V)
 Impedance loudspeakers 4 Ω
 Impedance headphones 32 Ω -1000 Ω

DVD PLAYER

Laser Type Semiconductor
 Disc Diameter 12cm / 8cm
 Video Decoding MPEG-2 / MPEG-1
 Video DAC 10 Bits
 Signal System PAL / NTSC
 Video Format 4:3 / 16:9
 Video S/N 56 dB (minimum)
 Composite Video Output 1.0 Vp-p, 75 Ω
 S-Video Output Y - 1.0 Vp-p, 75 Ω
 C - 0.286 Vp-p, 75 Ω
 Audio DAC 24 Bits / 96 kHz
 Frequency Response ... 4 Hz - 20 kHz (44.1kHz)
 4 Hz - 22 kHz (48kHz)
 4 Hz - 44 kHz (96kHz)
 Digital Output
 SPDIF (Sony Philips digital interface) Coaxial
 Number of programmable tracks 16
 Signal-to-noise ratio ≥ 65 dBA
 Channel separation ≥ 40 dB (1 kHz)
 Total harmonic distortion $< 0.1\%$ (1 kHz)

TUNER

FM wave range 87.5 – 108 MHz
 Sensitivity at 75 Ω
 – mono, 26 dB signal-to-noise ratio 2.8 μ V
 – stereo, 46 dB signal-to-noise ratio 61.4 μ V
 Selectivity ≥ 28 dB
 Total harmonic distortion $\leq 5\%$
 Frequency response 63 – 5500 Hz (-6 dB)
 Signal-to-noise-ratio ≥ 50 dBA

USB PLAYER

USB V2.0/ V1.1
 support MP3/WMA/JPEG files
 Number of albums/ folders maximum 99
 Number of tracks/titles maximum 500

SPEAKERS

2-way bass reflex system

GENERAL INFORMATION

AC Power 220 – 230 V / 50 Hz
 Standby power consumption ≤ 7 W
 Eco power Standby < 1 W

Dimensions

Main Unit(w x h x d) 152 x 228 x 285 (mm)
 Speakers (w x h x d)
 152 x 228 x 257 (mm)

Weight

With Packing 9.58 kg
 Main Unit 3.80 kg
 Speaker box 4.22 kg

Specifications and external appearance are subject to change without notice.

MEASUREMENT SETUP

Tuner FM

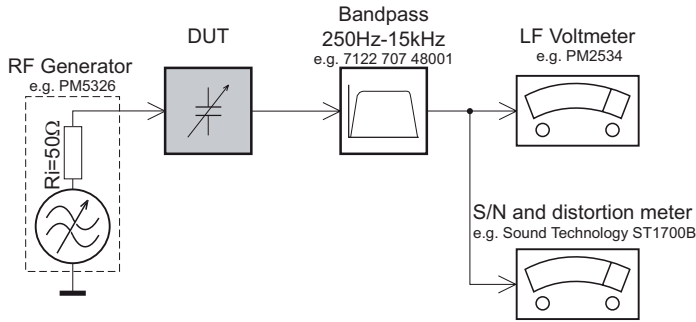

Use a bandpass filter to eliminate hum (50Hz, 100Hz) and disturbance from the pilotone (19kHz, 38kHz).

Tuner AM (MW,LW)

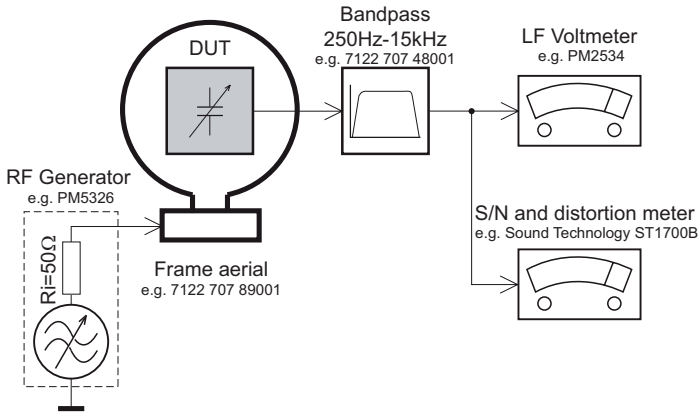

To avoid atmospheric interference all AM-measurements have to be carried out in a Faraday's cage. Use a bandpass filter (or at least a high pass filter with 250Hz) to eliminate hum (50Hz, 100Hz).

CD

Use Audio Signal Disc SBC429 4822 397 30184 (replaces test disc 3)

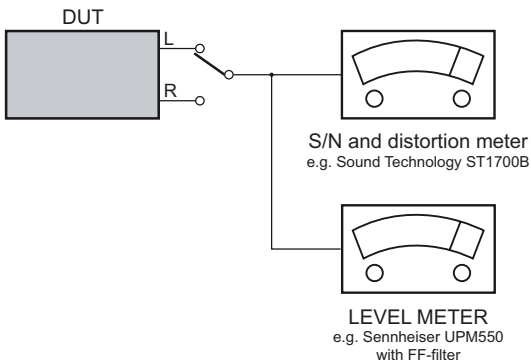

Recorder

Use Universal Test Cassette Cr02 SBC419 4822 397 30069 or Universal Test Cassette Fe SBC420 4822 397 30071

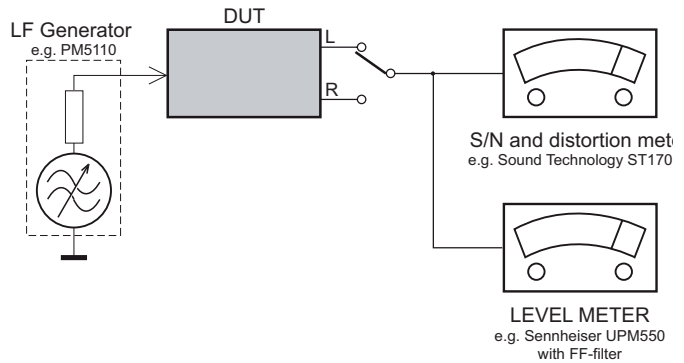

SERVICE AIDS

GB WARNING

All ICs and many other semi-conductors are susceptible to electrostatic discharges (ESD). Careless handling during repair can reduce life drastically.

When repairing, make sure that you are connected with the same potential as the mass of the set via a wrist wrap with resistance. Keep components and tools also at this potential.

ESD



GB

Safety regulations require that the set be restored to its original condition and that parts which are identical with those specified, be used

Safety components are marked by the symbol .

**CLASS 1
LASER PRODUCT**

INFORMATION ABOUT LEAD-FREE SOLDERING

Philips CE is producing lead-free sets from 1.1.2005 onwards.

IDENTIFICATION:

Regardless of special logo (not always indicated) one must treat all sets from 1 Jan 2005 onwards, according next rules:



- On our website www.atyourservice.ce.philips.com you find more information to:
 - * BGA-de-/soldering (+ baking instructions)
 - * Heating-profiles of BGAs and other ICs used in Philips-sets
 - * Lead free

You will find this and more technical information within the "magazine", chapter "workshop news".

For additional questions please contact your local repair-helpdesk.

SERVICE INSTRUCTION

Safety regulations require that after a repair, the set must be returned in its original condition. Pay in particular attention to the following points:

- Route the wire trees correctly and fix them with the mounted cable clamps.
- Check the insulation of the AC Power lead for external damage.
- Check the strain relief of the AC Power cord for proper function.
- Check the electrical DC resistance between the AC Power Plug and the secondary side (only for sets which have a AC Power isolated power supply):
 1. Unplug the AC Power cord and connect a wire between the two pins of the AC Power plug.
 2. Set the AC Power switch to the "on" position (keep the AC Power cord unplugged!).
 3. Measure the resistance value between the pins of the AC Power plug and the metal shielding of the tuner or the aerial connection on the set. The reading should be larger than 4.5 Mohm (For U.S. it should be between 4.2 Mohm and 12 Mohm).
 4. Switch "off" the set, and remove the wire between the two pins of the AC Power plug.
- Check the cabinet for defects, to avoid touching of any inner parts by the customer.

INSTRUCTIONS ON CD PLAYABILITY

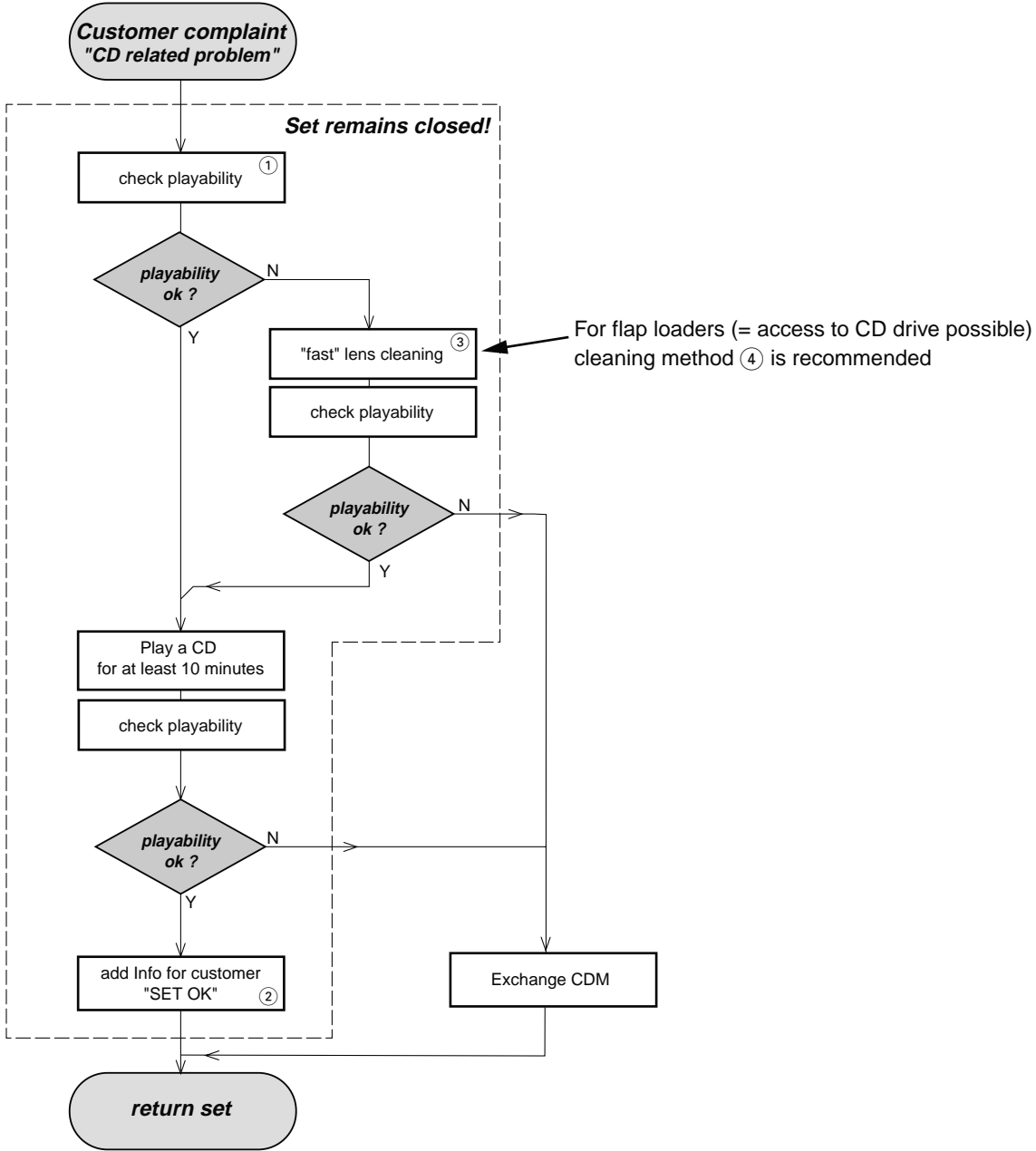

For flap loaders (= access to CD drive possible) cleaning method ④ is recommended

① - ④ For description - see following pages

INSTRUCTIONS ON CD PLAYABILITY

①

PLAYABILITY CHECK

For sets which are compatible with **CD-RW** discs
 use CD-RW Printed Audio Disc7104 099 96611
 TR 3 (Fingerprint)
 TR 8 (600µ Black dot) **maximum at 01:00**

- playback of these two tracks without audible disturbance
 playing time for: Fingerprint ≥ 10 seconds
 Black dot from 00:50 to 01:10
- jump forward/backward (search) within a reasonable time

For all other sets
 use CD-DA SBC 444A4822 397 30245
 TR 14 (600µ Black dot) **maximum at 01:15**
 TR 19 (Fingerprint)
 TR 10 (1000µ wedge)

- playback of all these tracks without audible disturbance
 playing time for: 1000µ wedge ≥ 10 seconds
 Fingerprint ≥ 10 seconds
 Black dot from 01:05 to 01:25
- jump forward/backward (search) within a reasonable time

②

CUSTOMER INFORMATION

It is proposed to add an addendum sheet to the set which informs the customer that the set has been checked carefully - but no fault was found.

The problem was obviously caused by a scratched, dirty or copy-protected CD. In case problems remain, the customer is requested to contact the workshop directly.

The lens cleaning (method ③) should be mentioned in the addendum sheet.

The final wording in national language as well as the printing is under responsibility of the Regional Service Organizations.

④

LIQUID LENS CLEANING

Before touching the lens it is advised to clean the surface of the lens by blowing clean air over it. This to avoid that little particles make scratches on the lens.

Because the material of the lens is synthetic and coated with a special anti-reflectivity layer, cleaning must be done with a non-aggressive cleaning fluid. It is advised to use "Cleaning Solvent

The actuator is a very precise mechanical component and may not be damaged in order to guarantee its full function. Clean the lens gently (don't press too hard) with a soft and clean cotton bud moistened with the special lens cleaner.

The direction of cleaning must be in the way as indicated in the picture below.

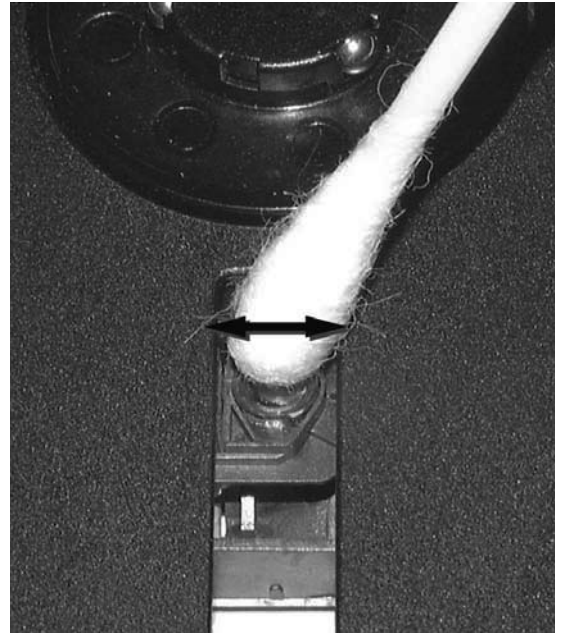

SOFTWARE VERSION CHECKING AND REGION CODE RESET**How to set region code:**

- 1) Press "SYSTEM MENU" on Remote Control ---->select "DEFAULT" and then select "RESTORE" .
It can reset the region code.
- 2) To change the region code ----> open CD door at CD mode and press "5168" on RC ----> select "REGION" and select region code.

Software checking:

- 1) MCU version : at standby mode, press and hold "DBB" & "PLAY" buttons at the same time.
Servo version : CD mode, open CD door and press "5168" on Remote Control.

SET BLOCK DIAGRAM

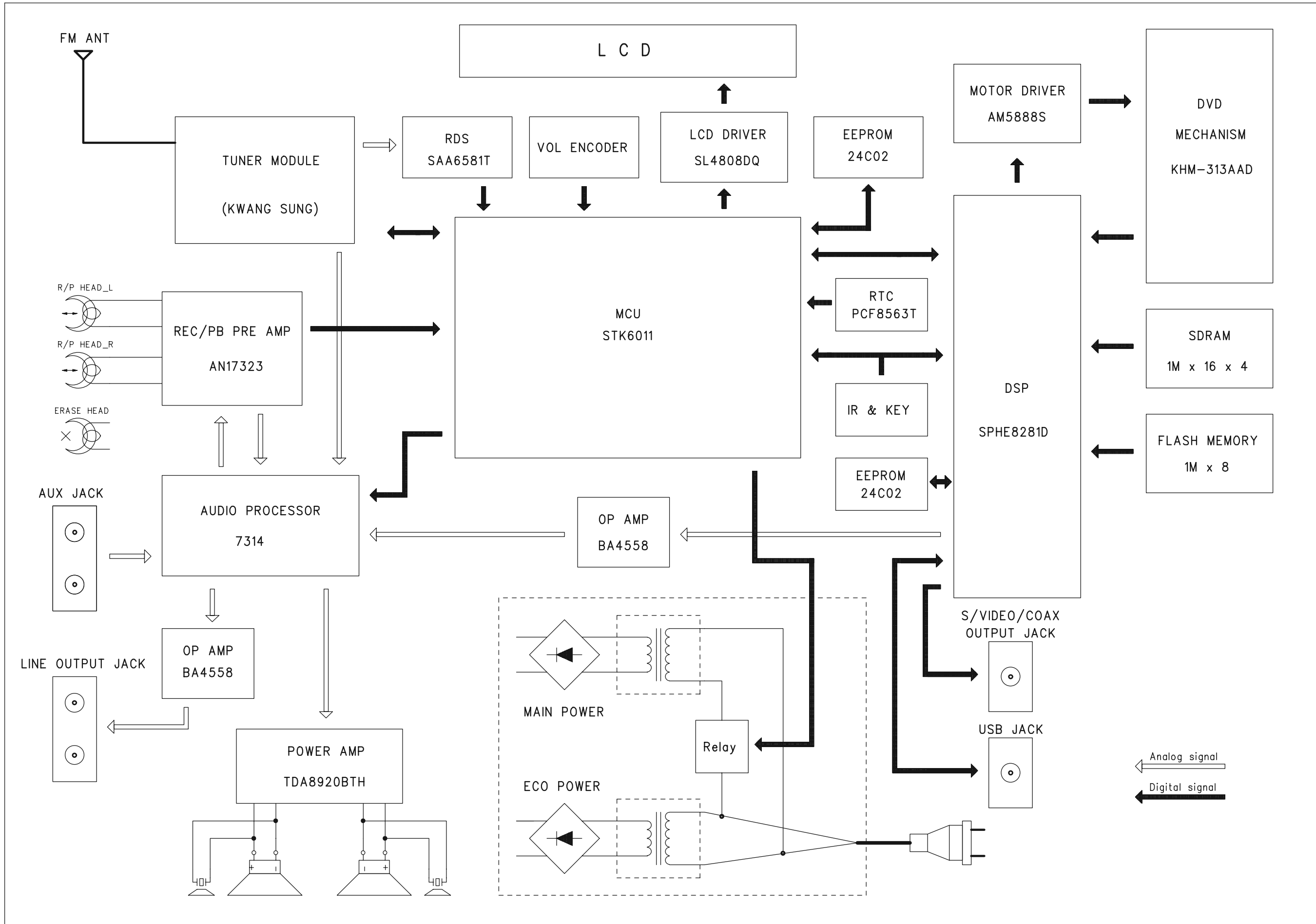

SET WIRING DIAGRAM

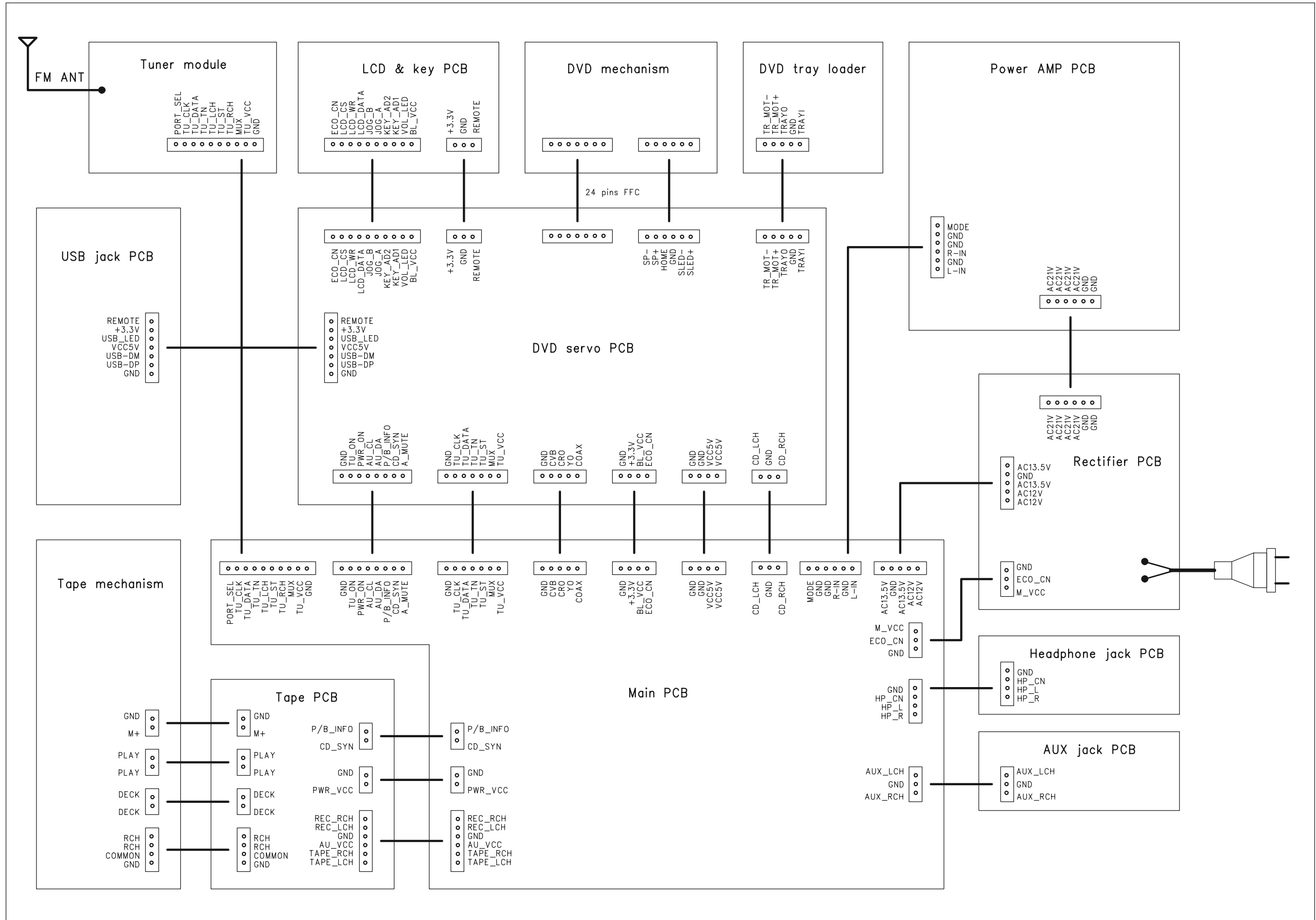

CIRCUIT DIAGRAM - LCD & KEY BOARD Part 1

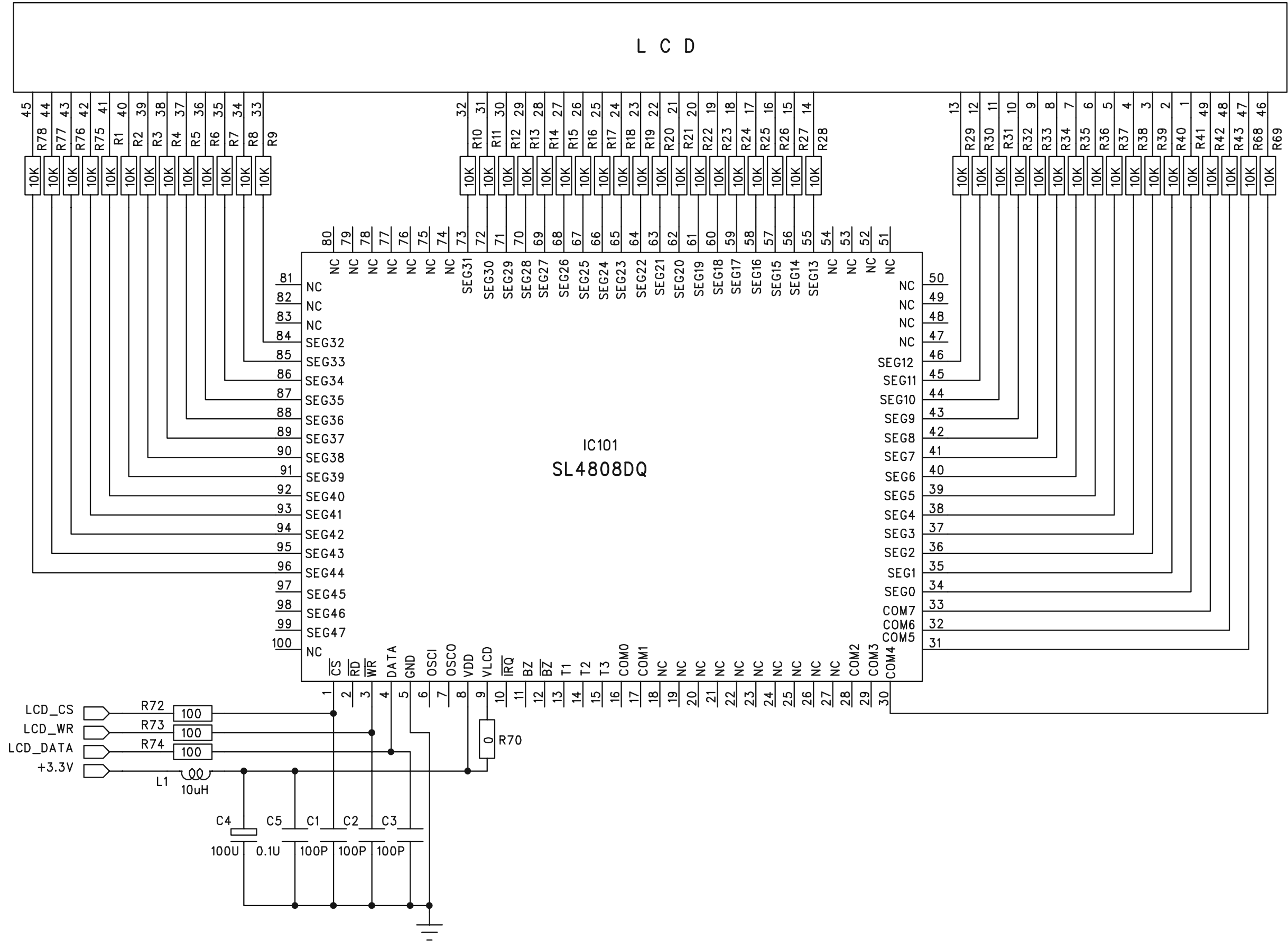

CIRCUIT DIAGRAM - LCD & KEY BOARD
Part 2

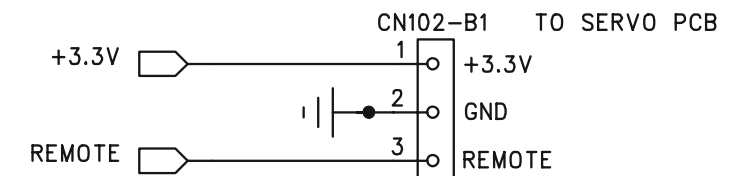
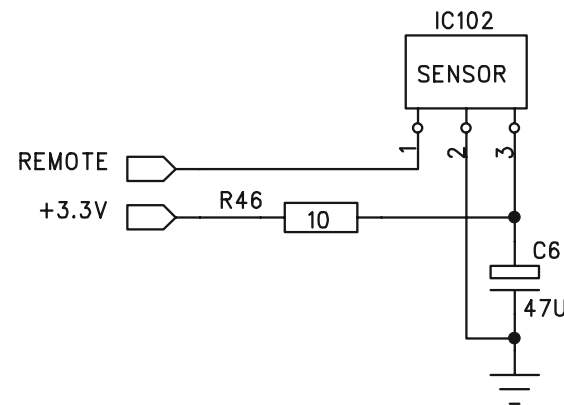
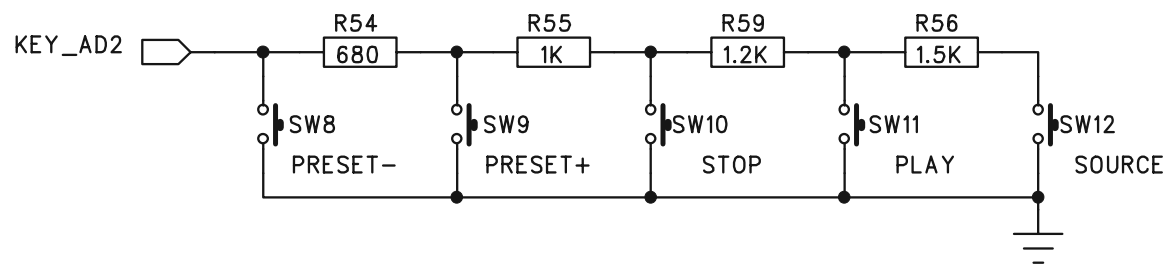
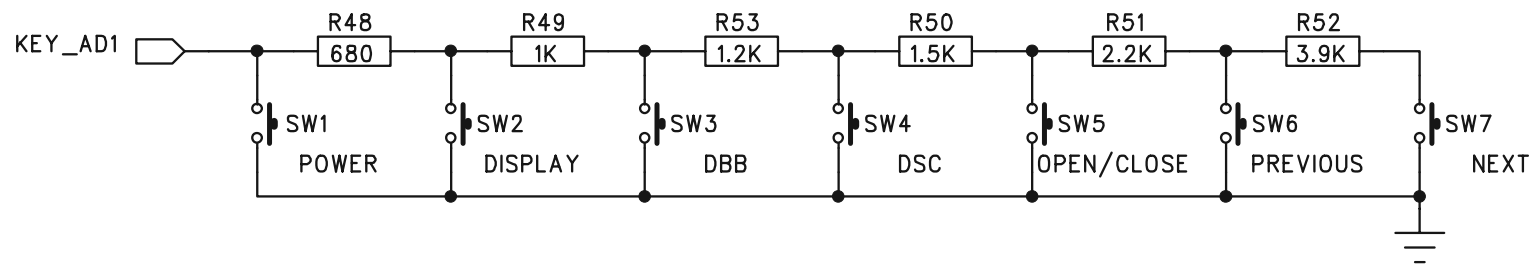
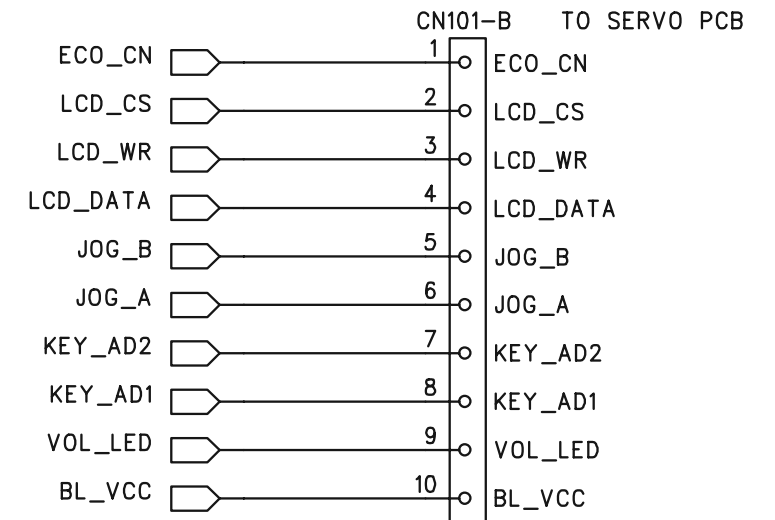
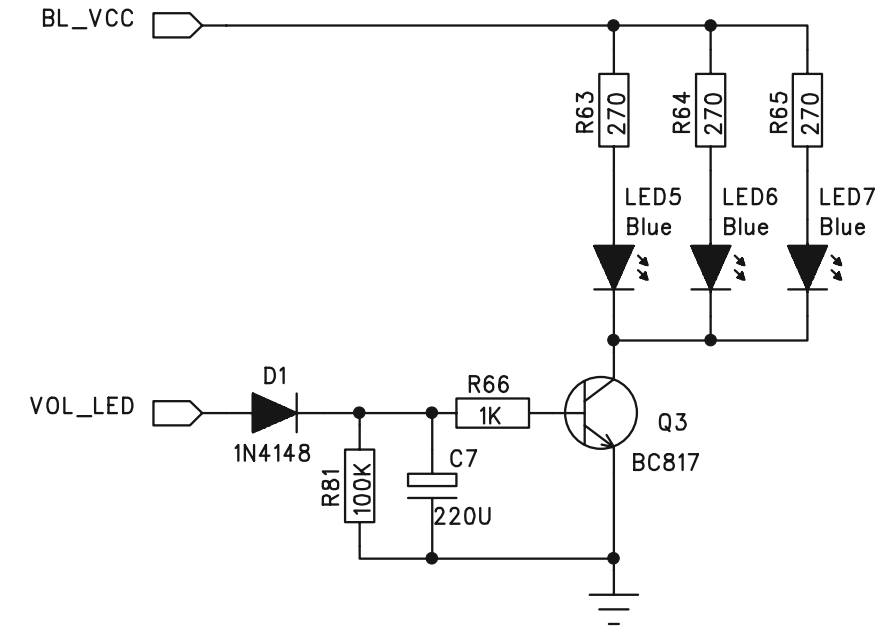
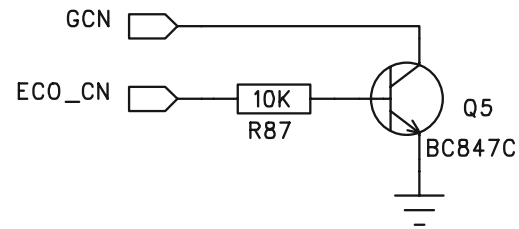
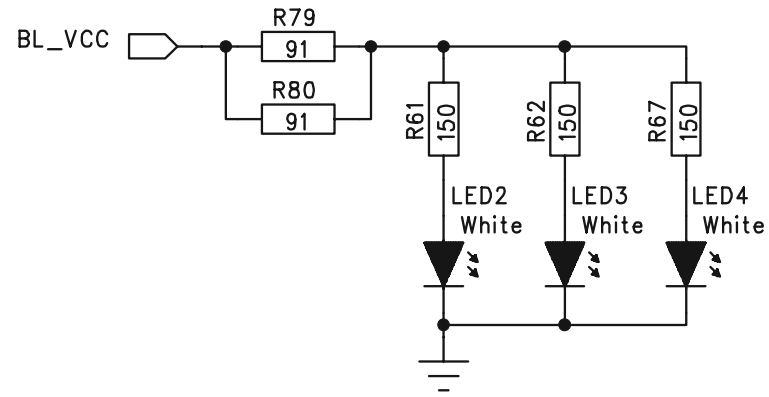
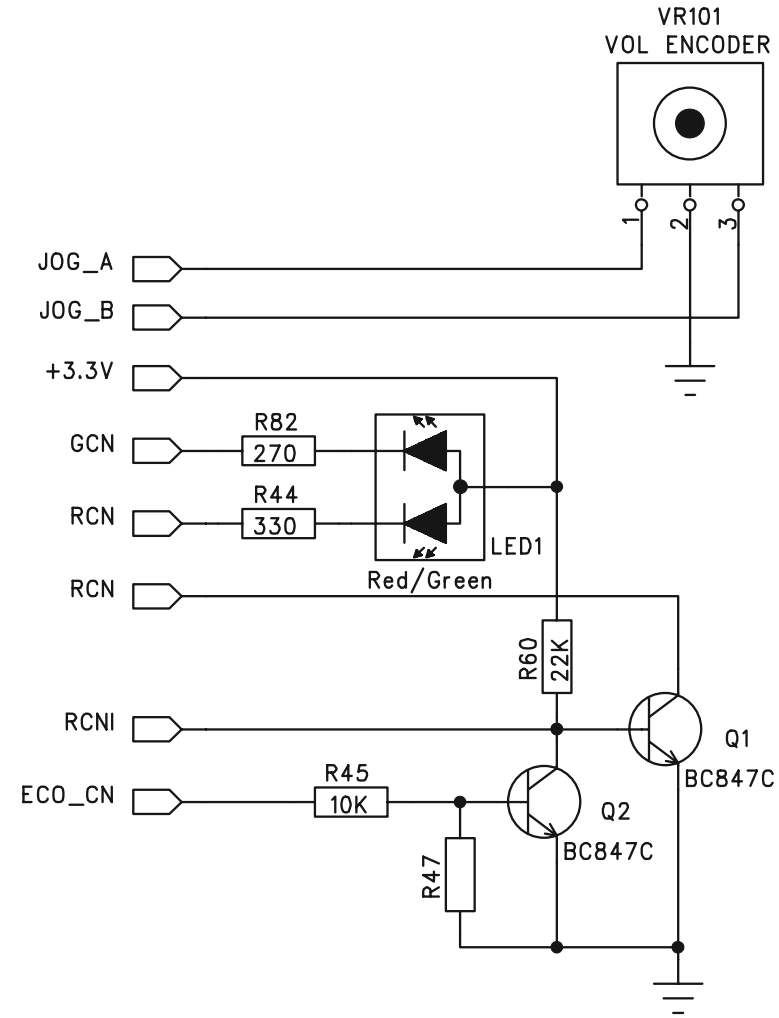

LAYOUT DIAGRAM - LCD & KEY BOARD

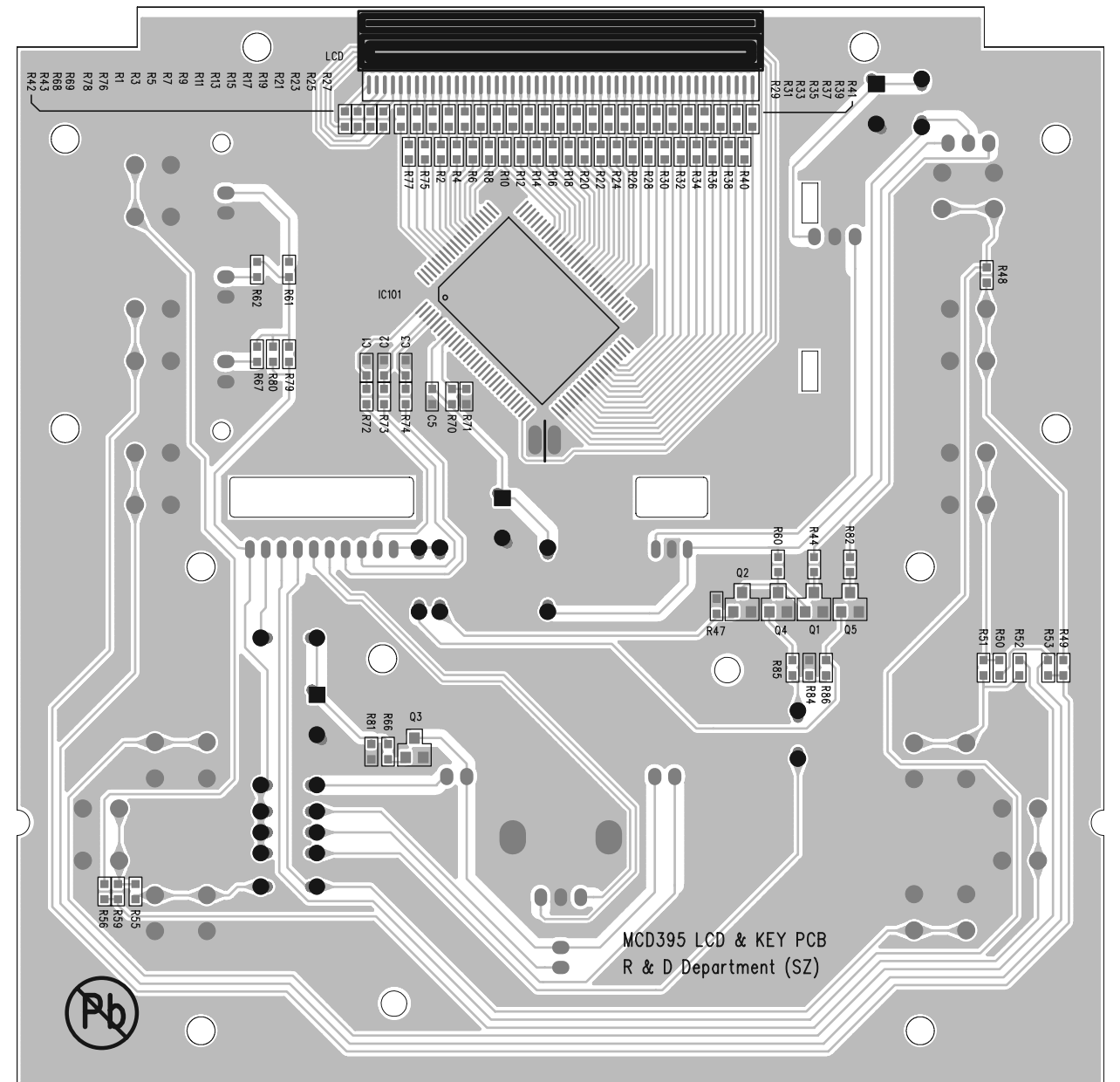
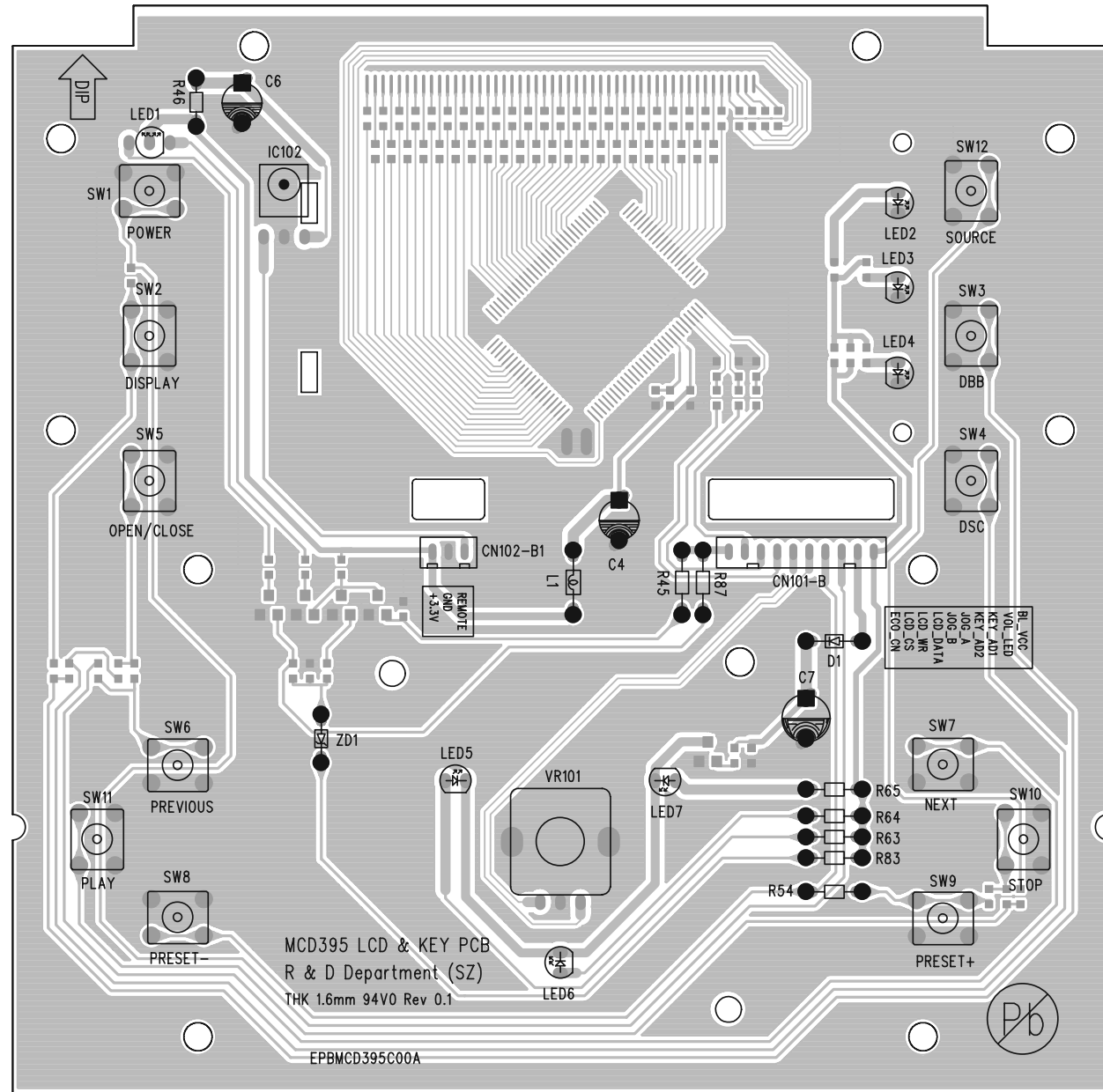

CIRCUIT DIAGARM - RECTIFIER BOARD

CIRCUIT DIAGARM - RECTIFIER BOARD

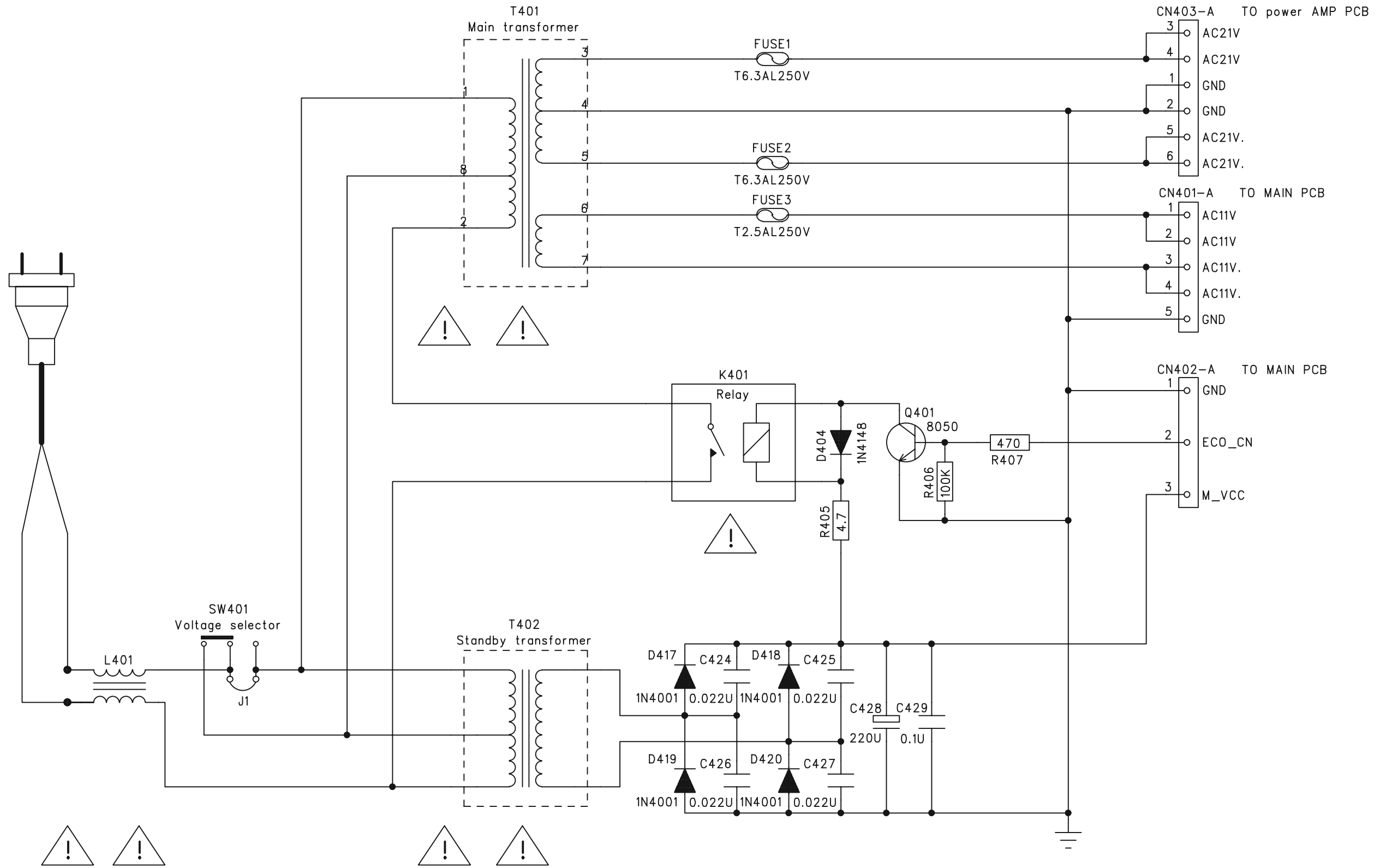

LAYOUT DIAGARM - RECTIFIER BOARD TOP VIEW

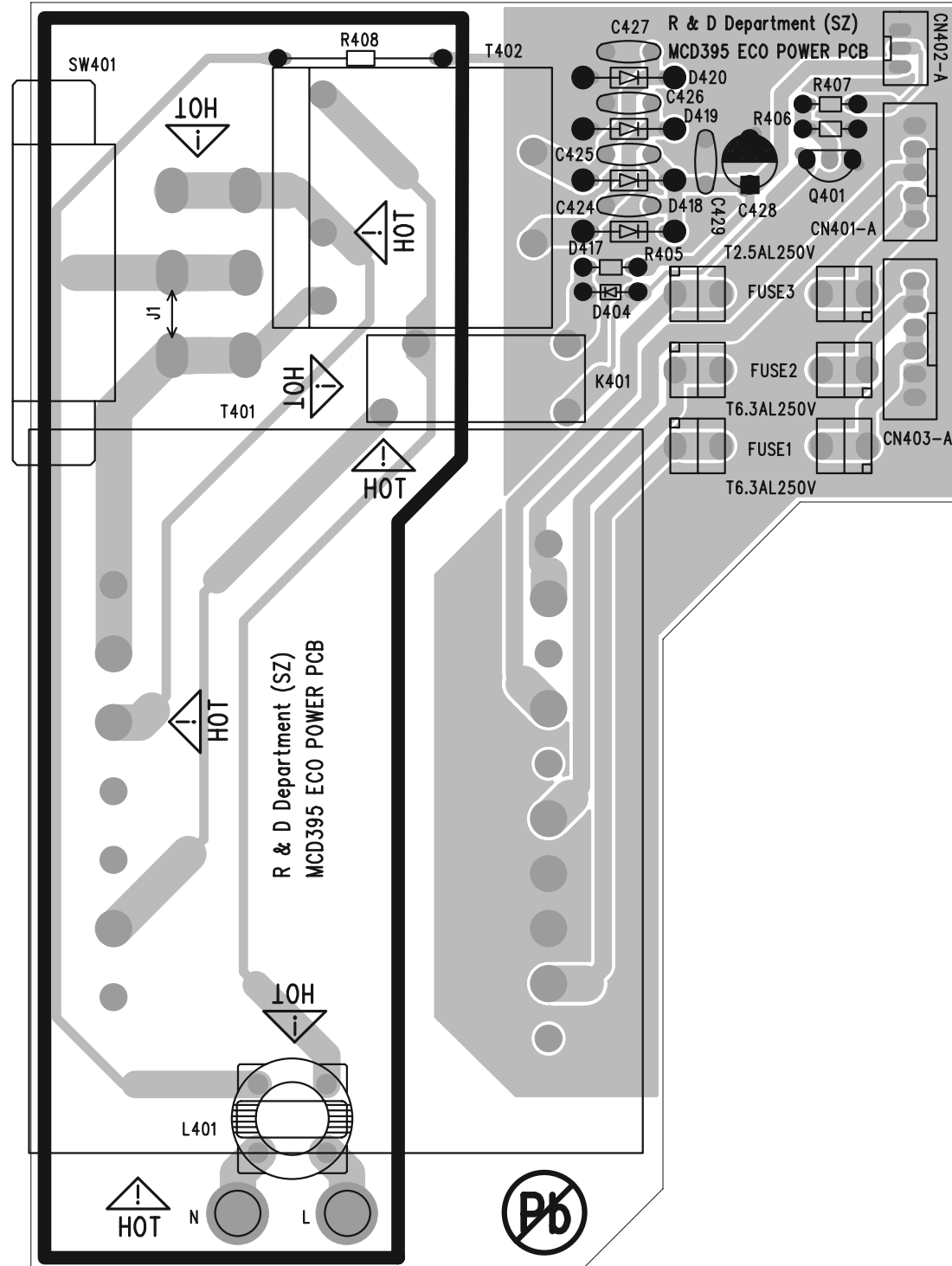

LAYOUT DIAGARM - RECTIFIER BOARD BOTTOM VIEW

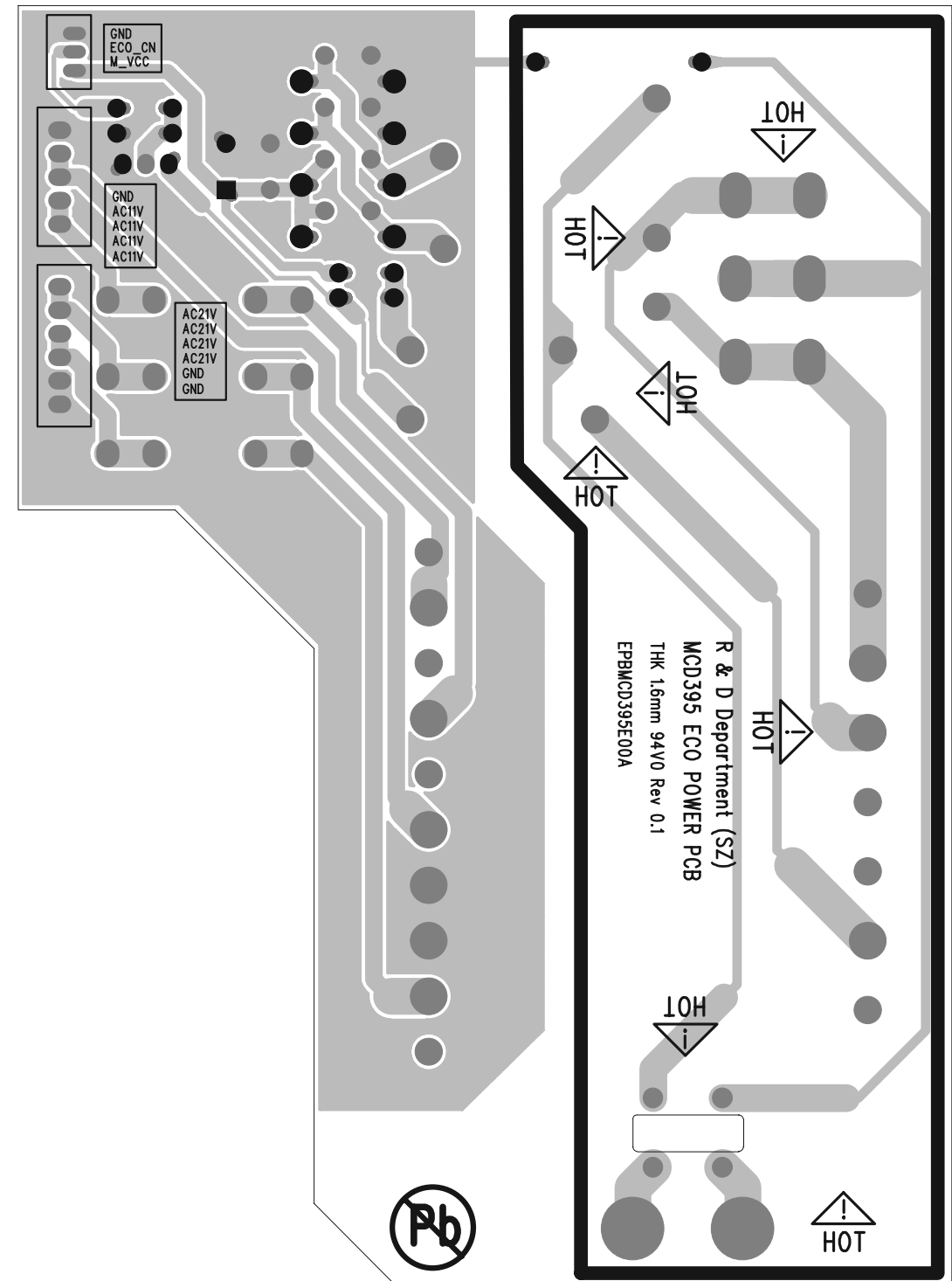

CIRCUIT DIAGARM - POWER AMP BOARD PART1

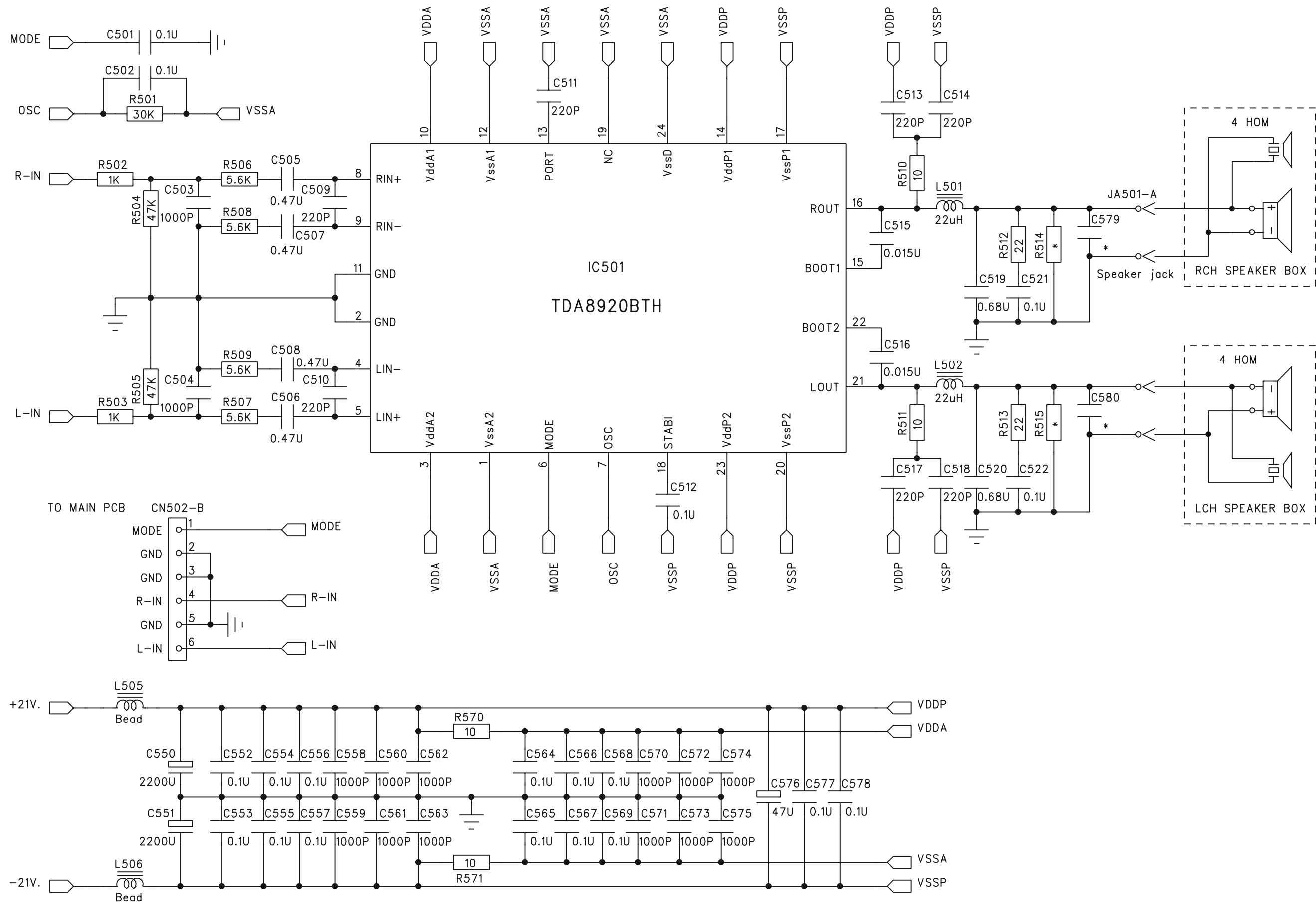

CIRCUIT DIAGARM - POWER AMP BOARD PART2

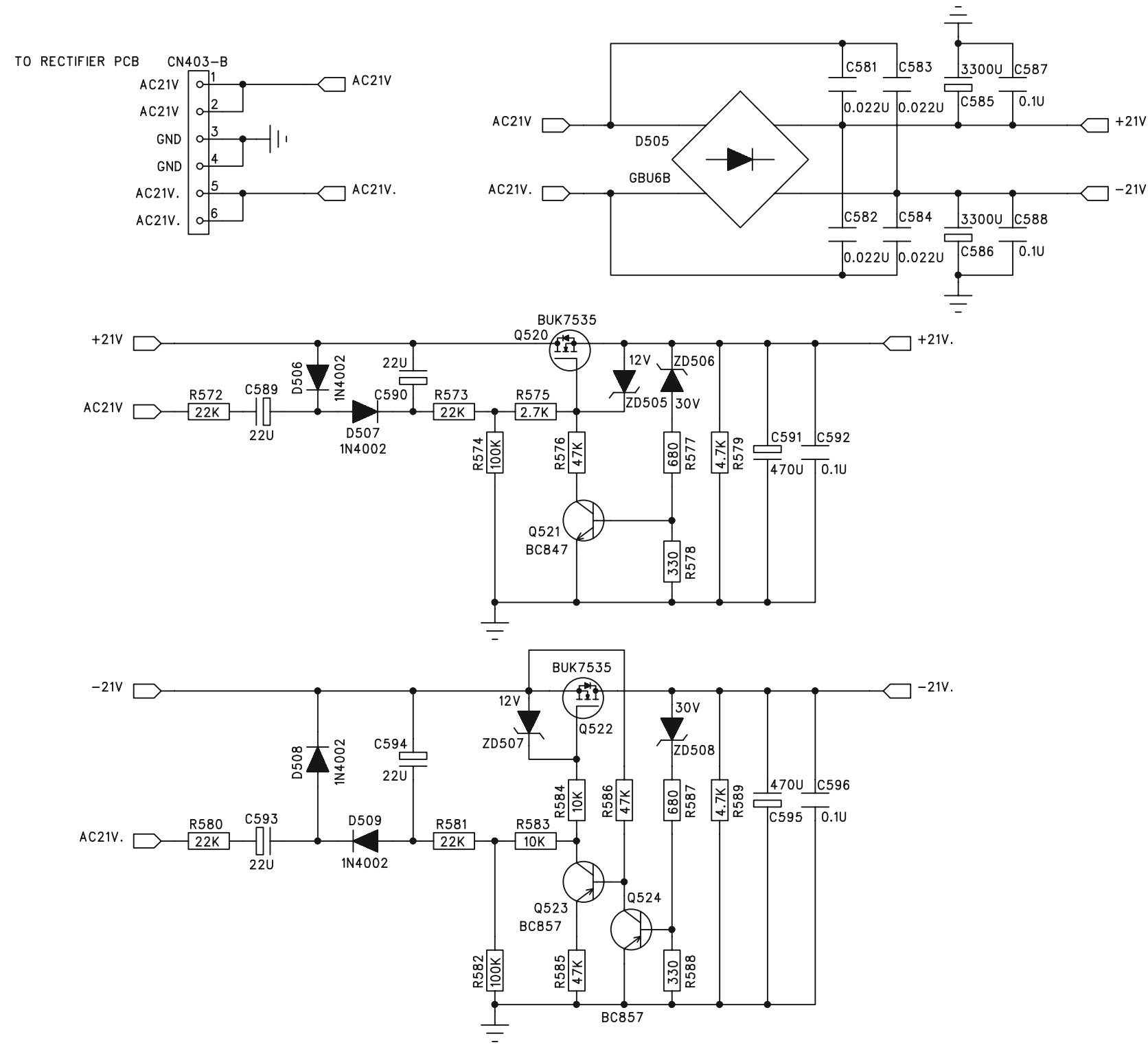

LAYOUT DIAGARM - POWER AMP BOARD

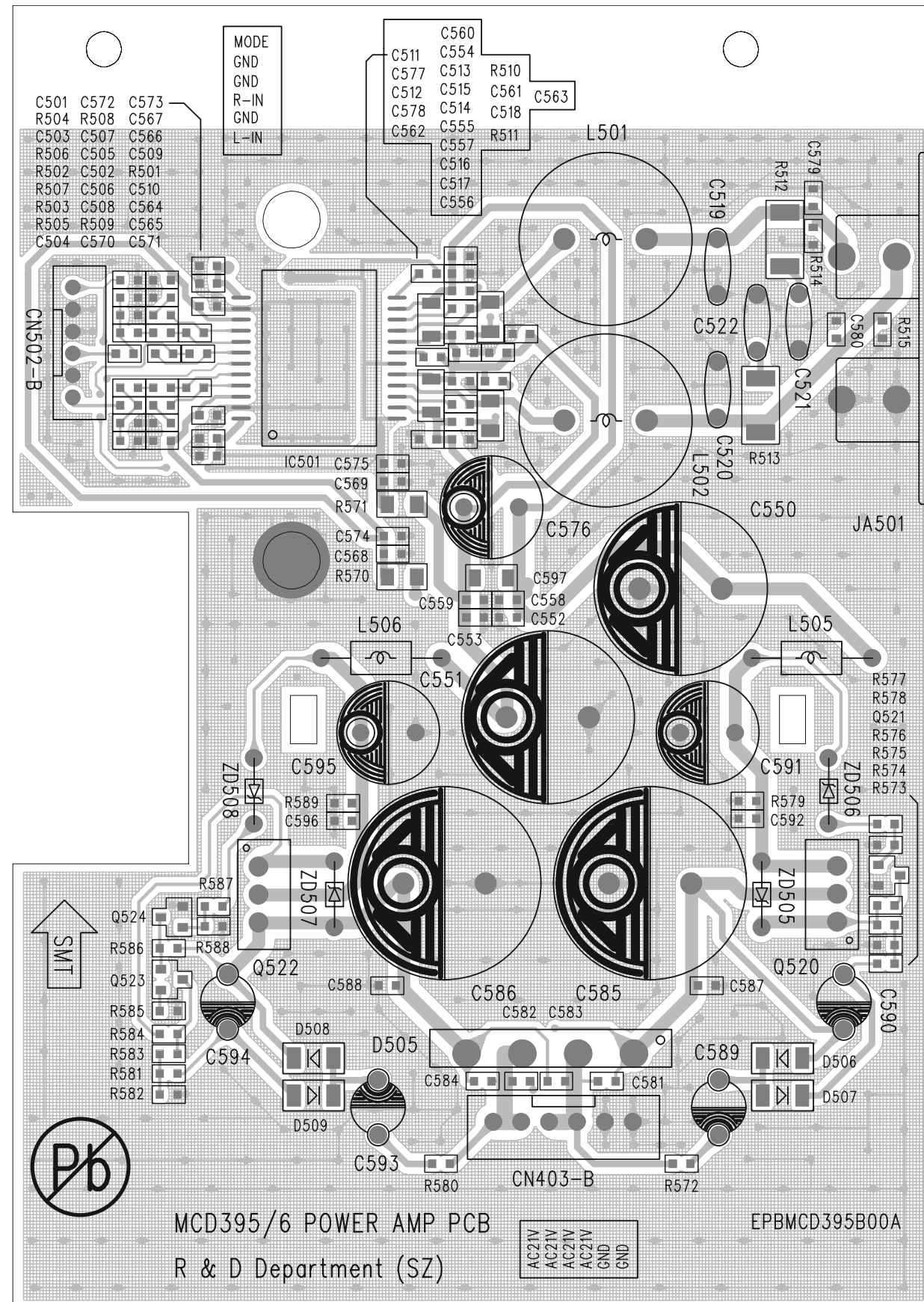

CIRCUIT DIAGRAM - MAIN BOARD

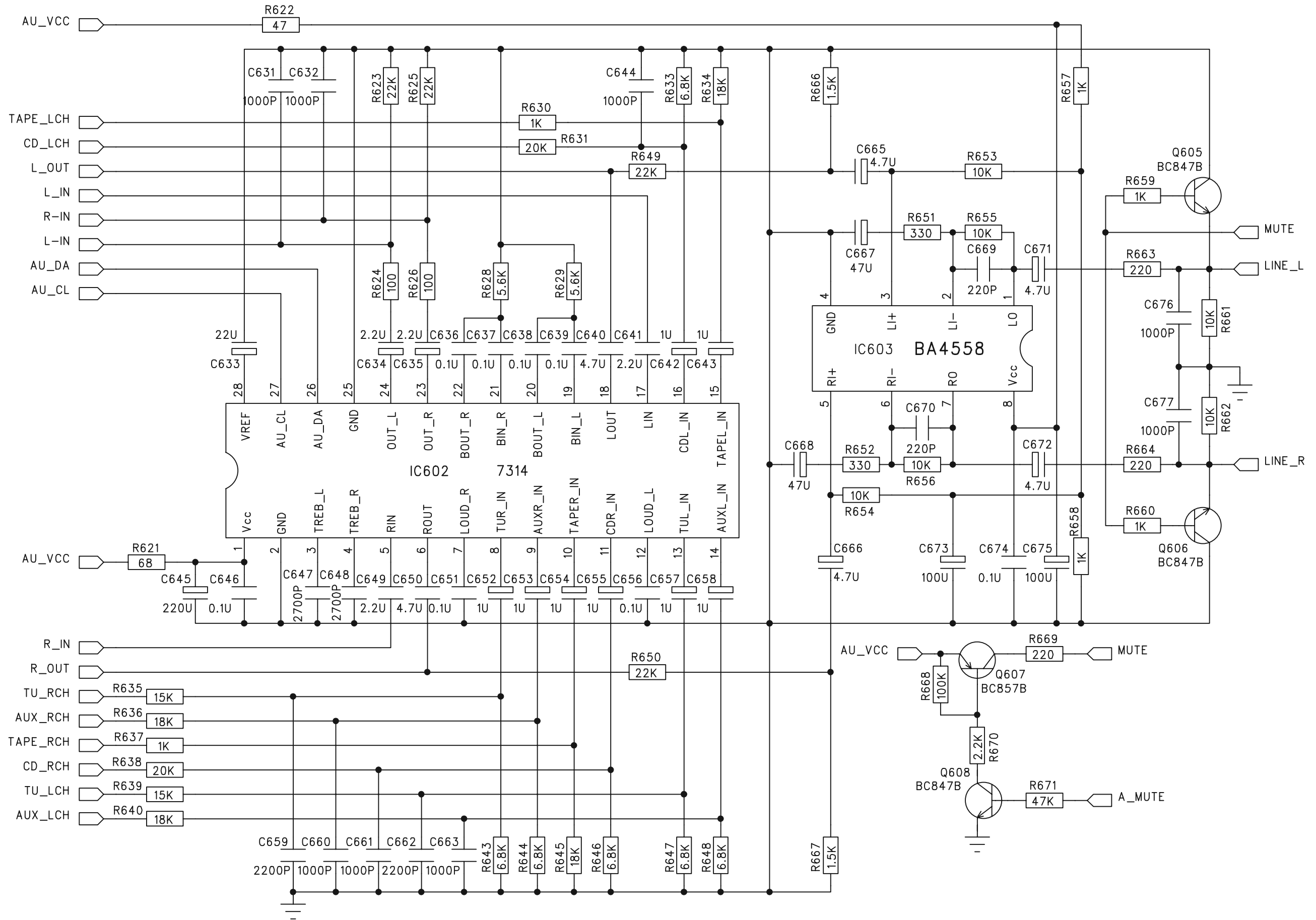

CIRCUIT DIAGRAM - MAIN BOARD

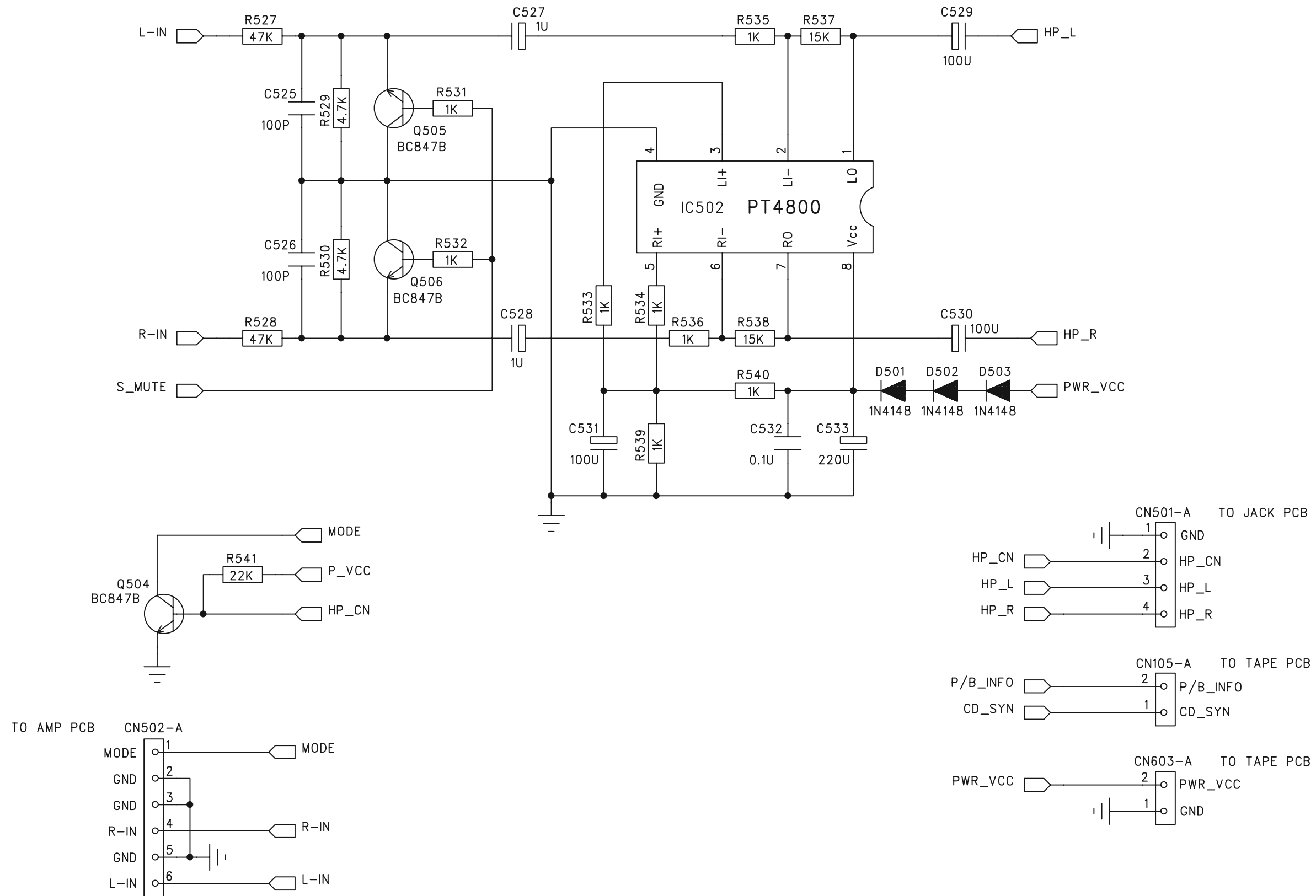

CIRCUIT DIAGRAM - MAIN BOARD

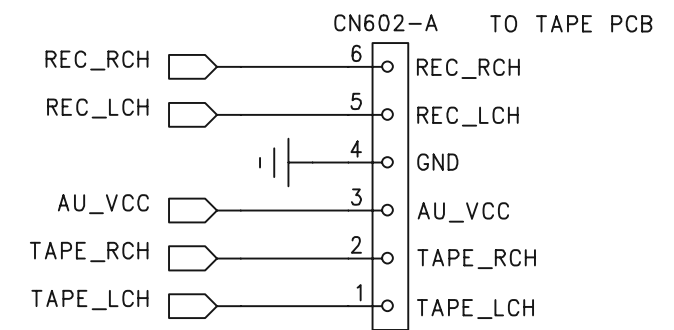
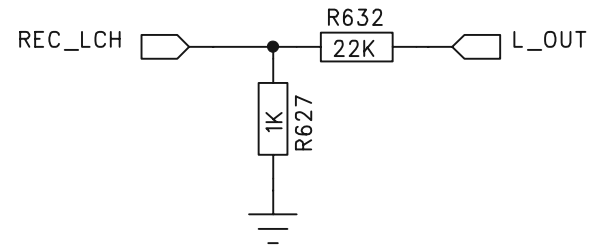
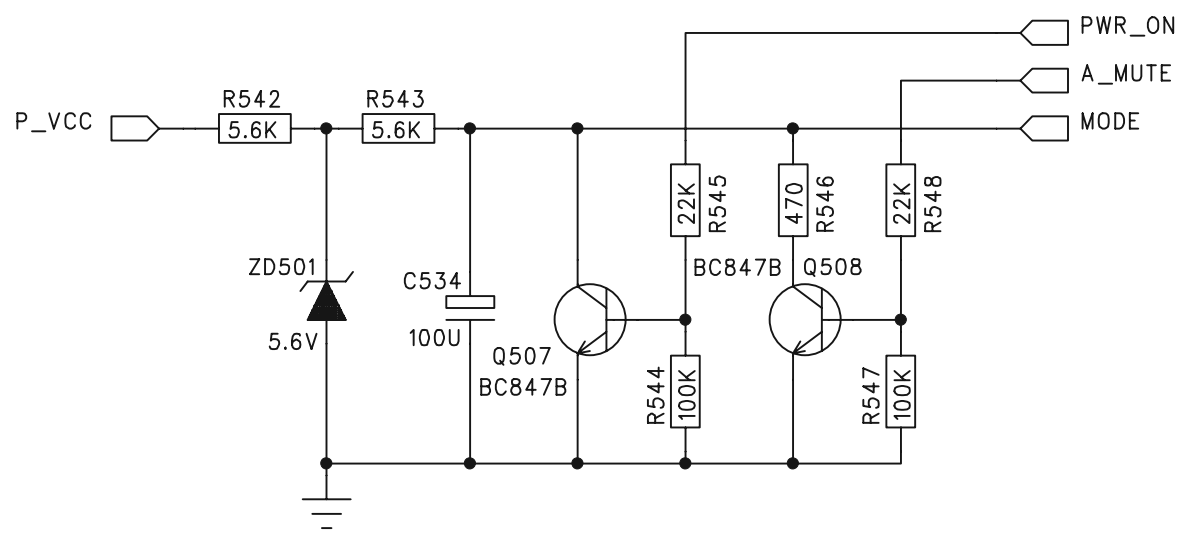
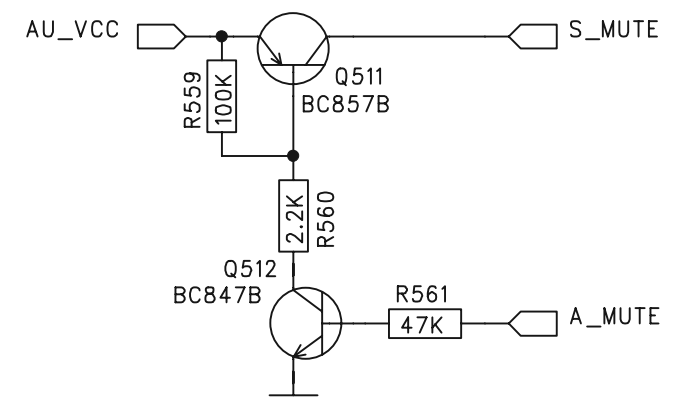
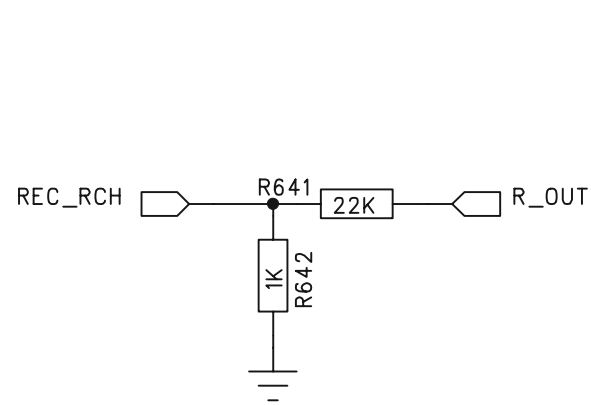
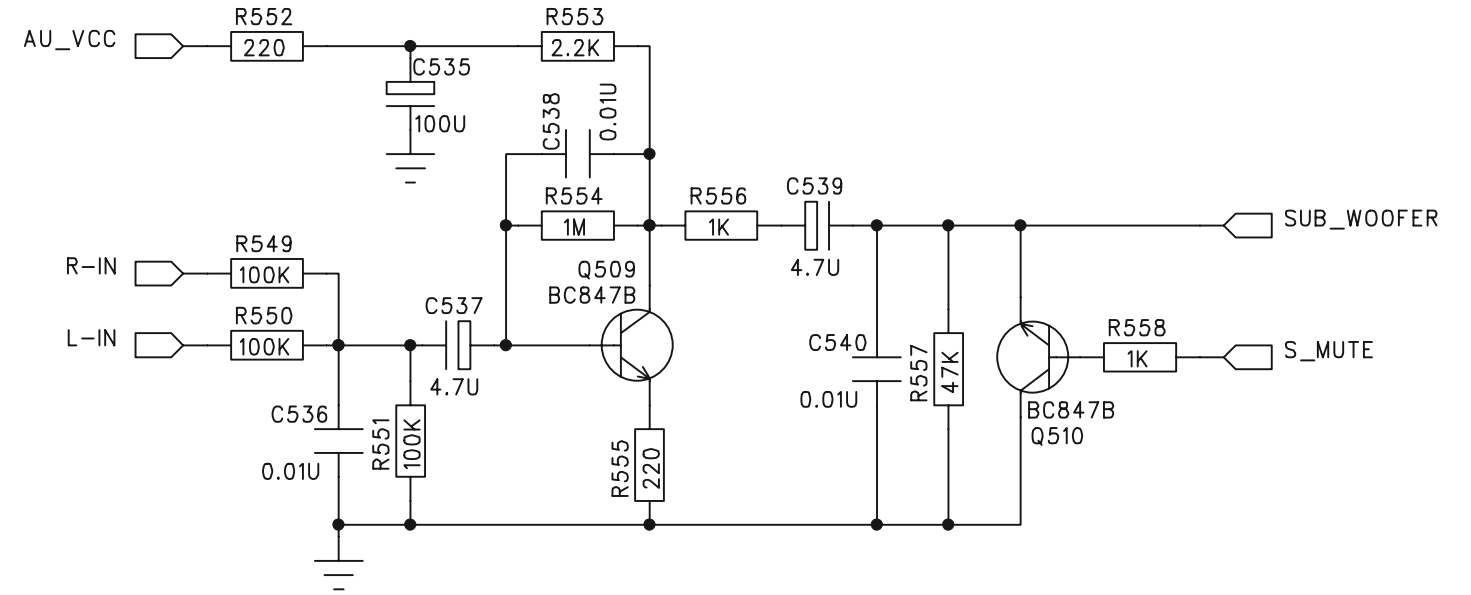
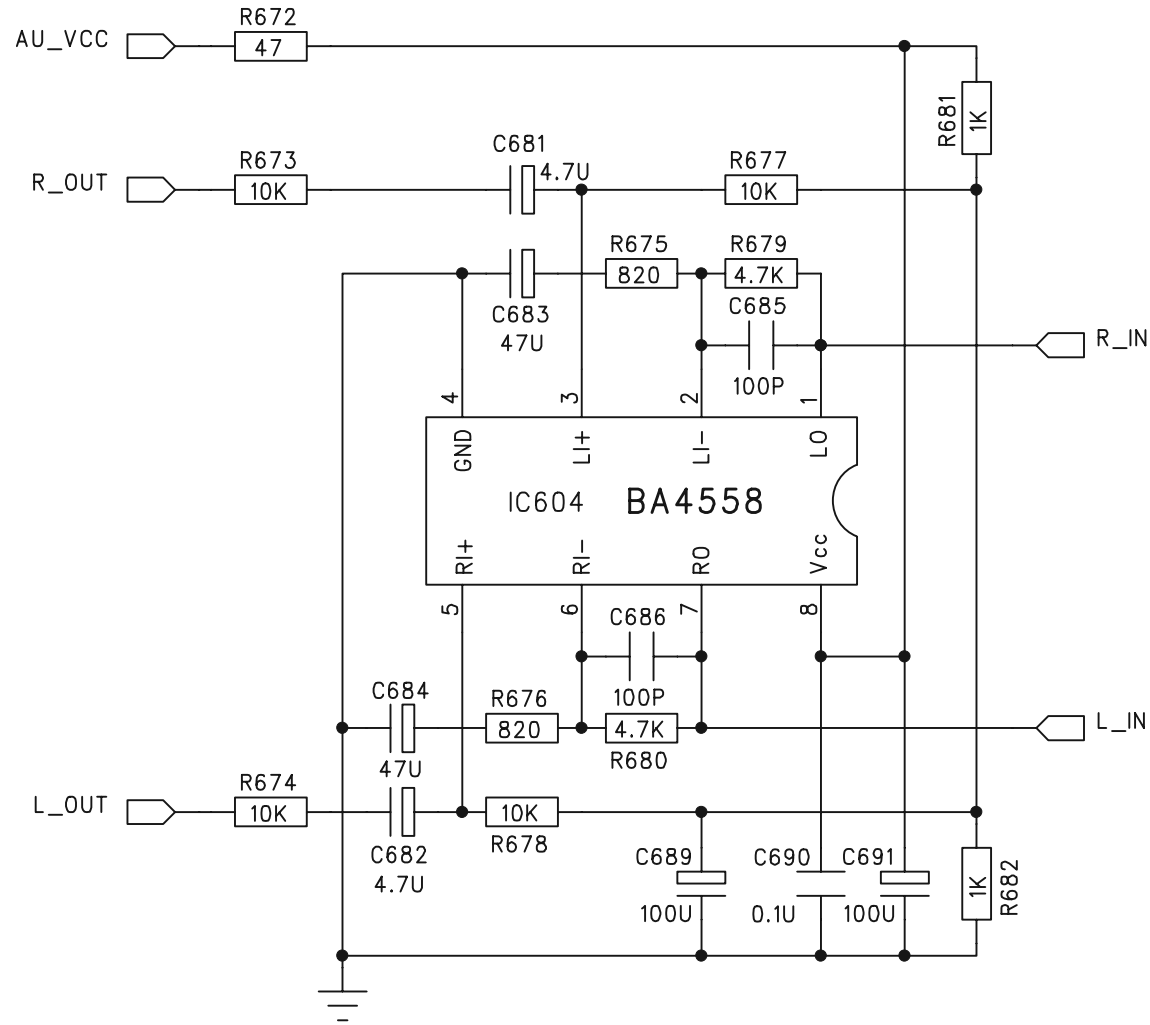

CIRCUIT DIAGRAM - MAIN BOARD

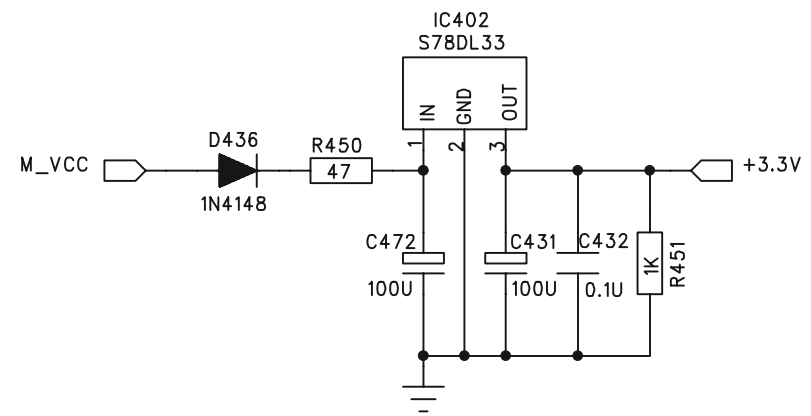
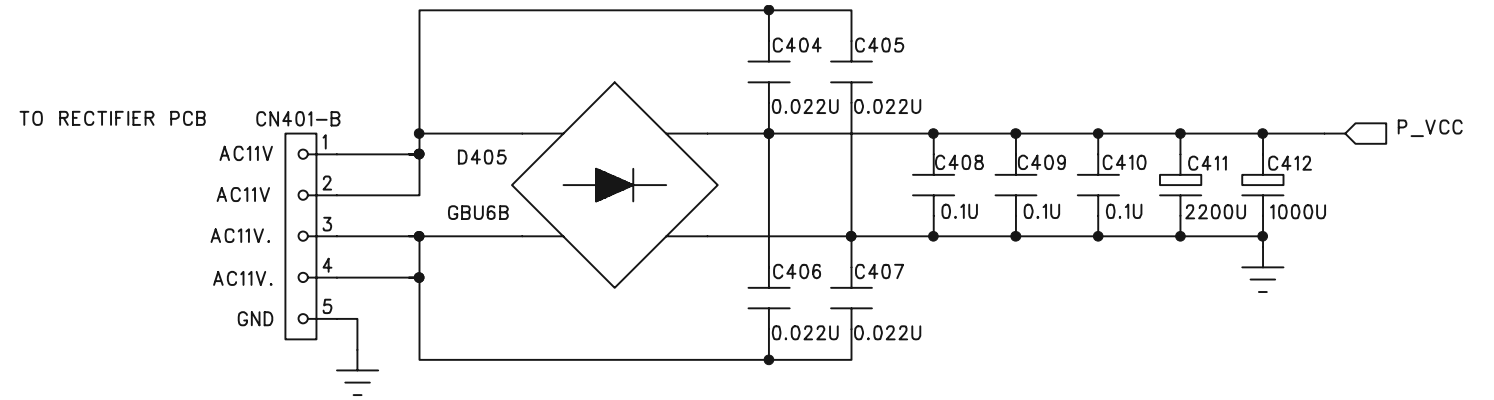
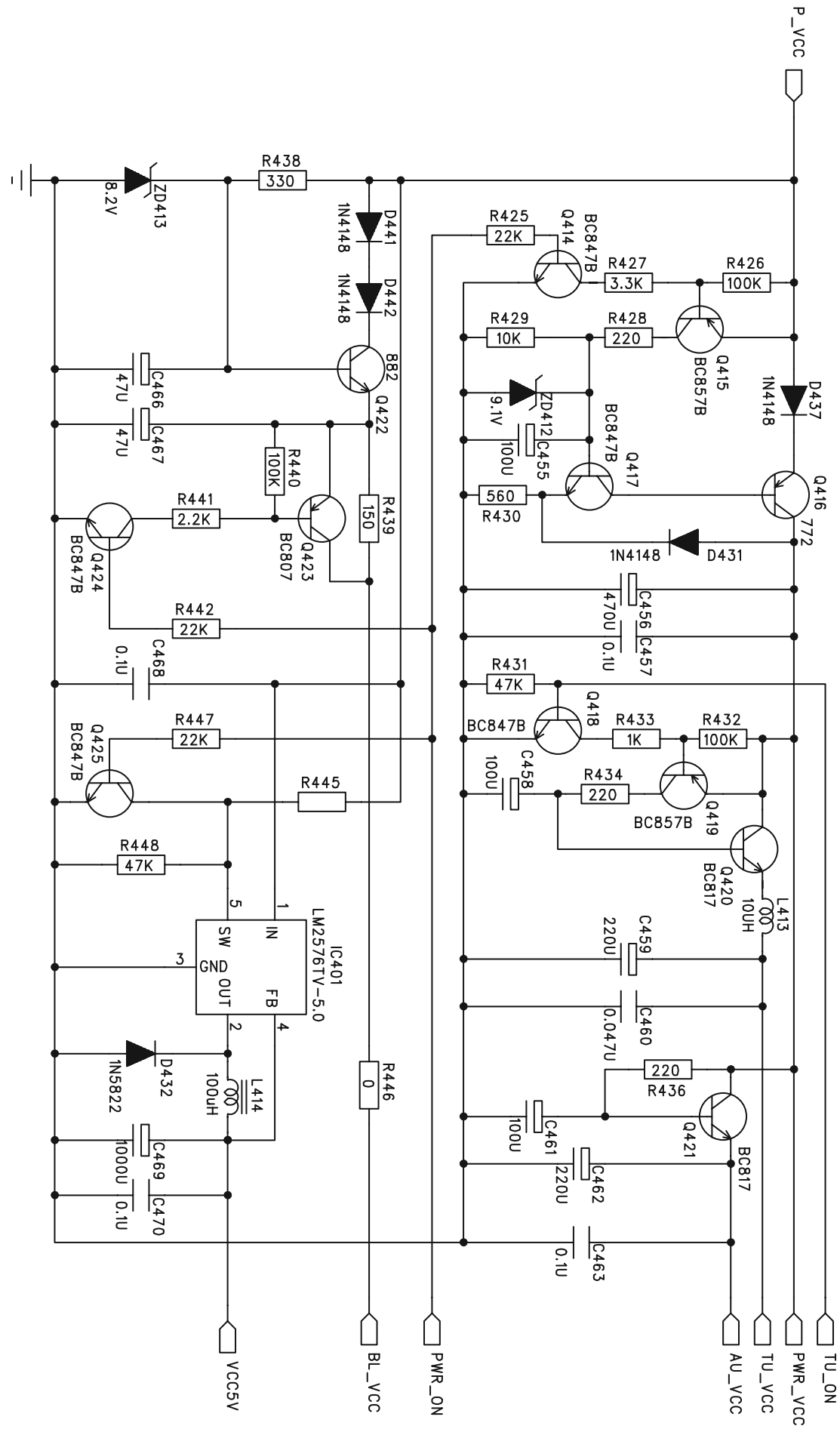

CIRCUIT DIAGRAM - MAIN BOARD

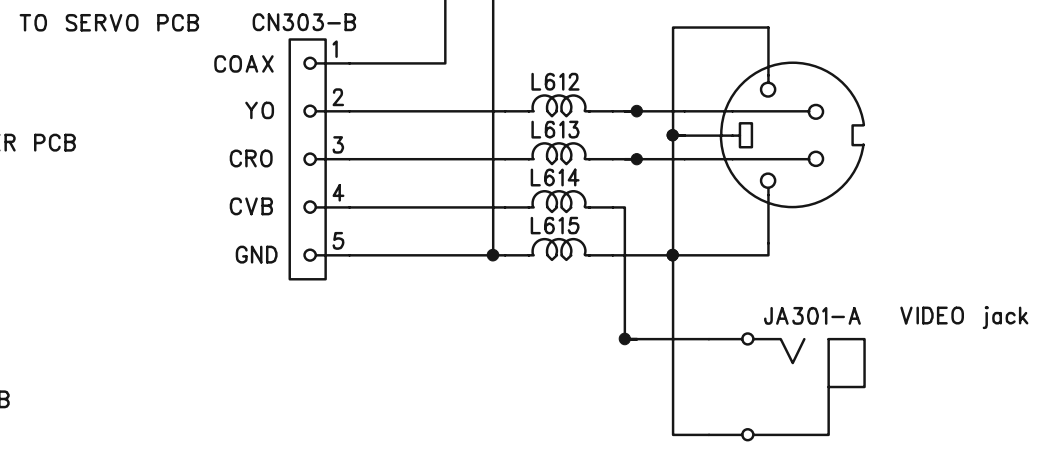
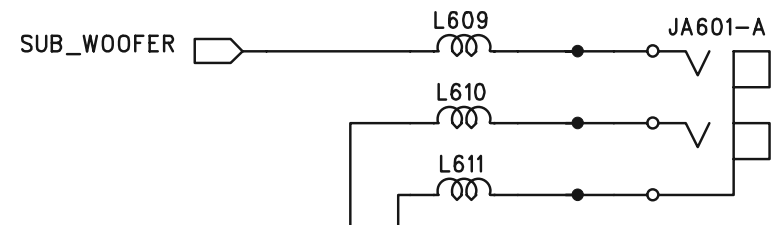
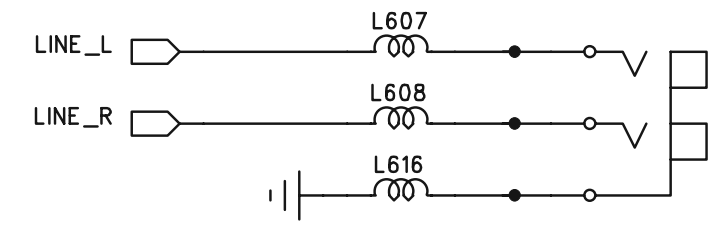
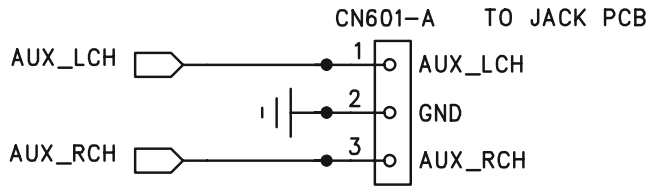
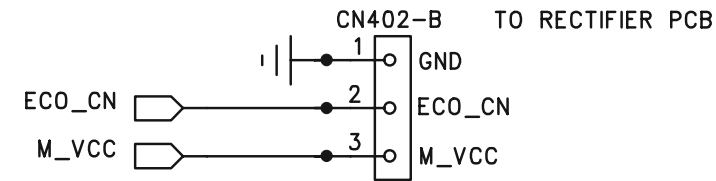
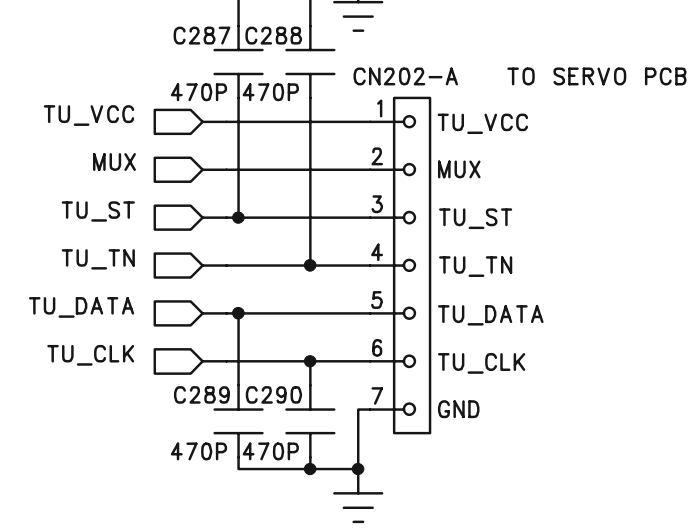
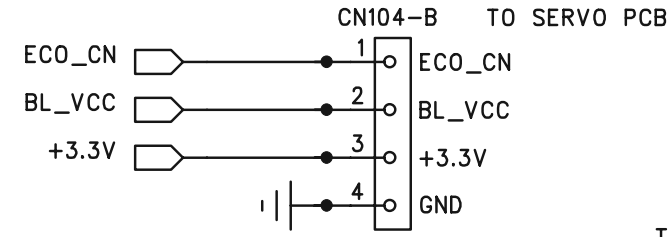
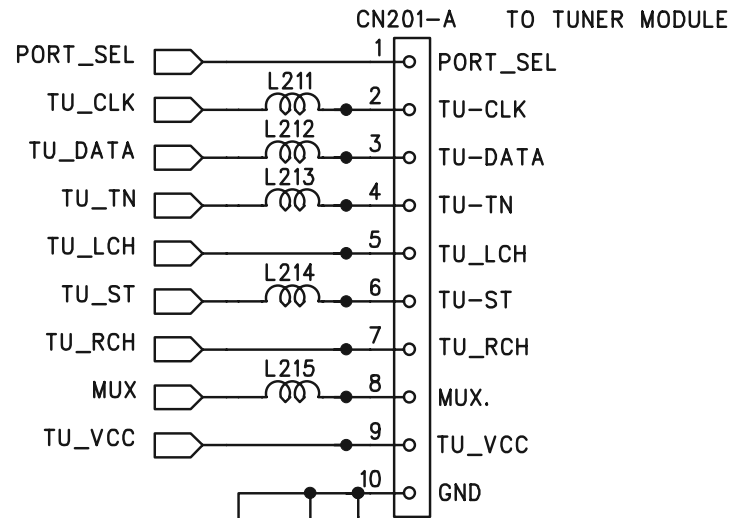
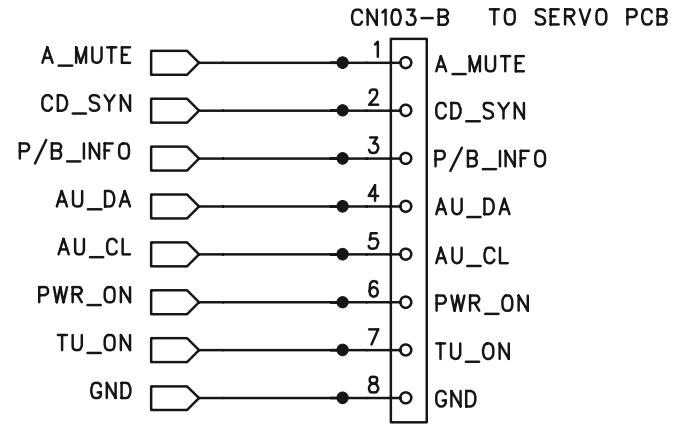
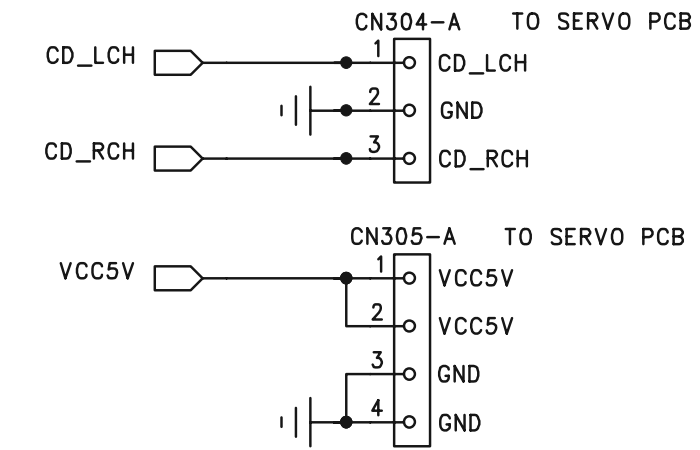

LAYOUT DIAGRAM - MAIN BOARD

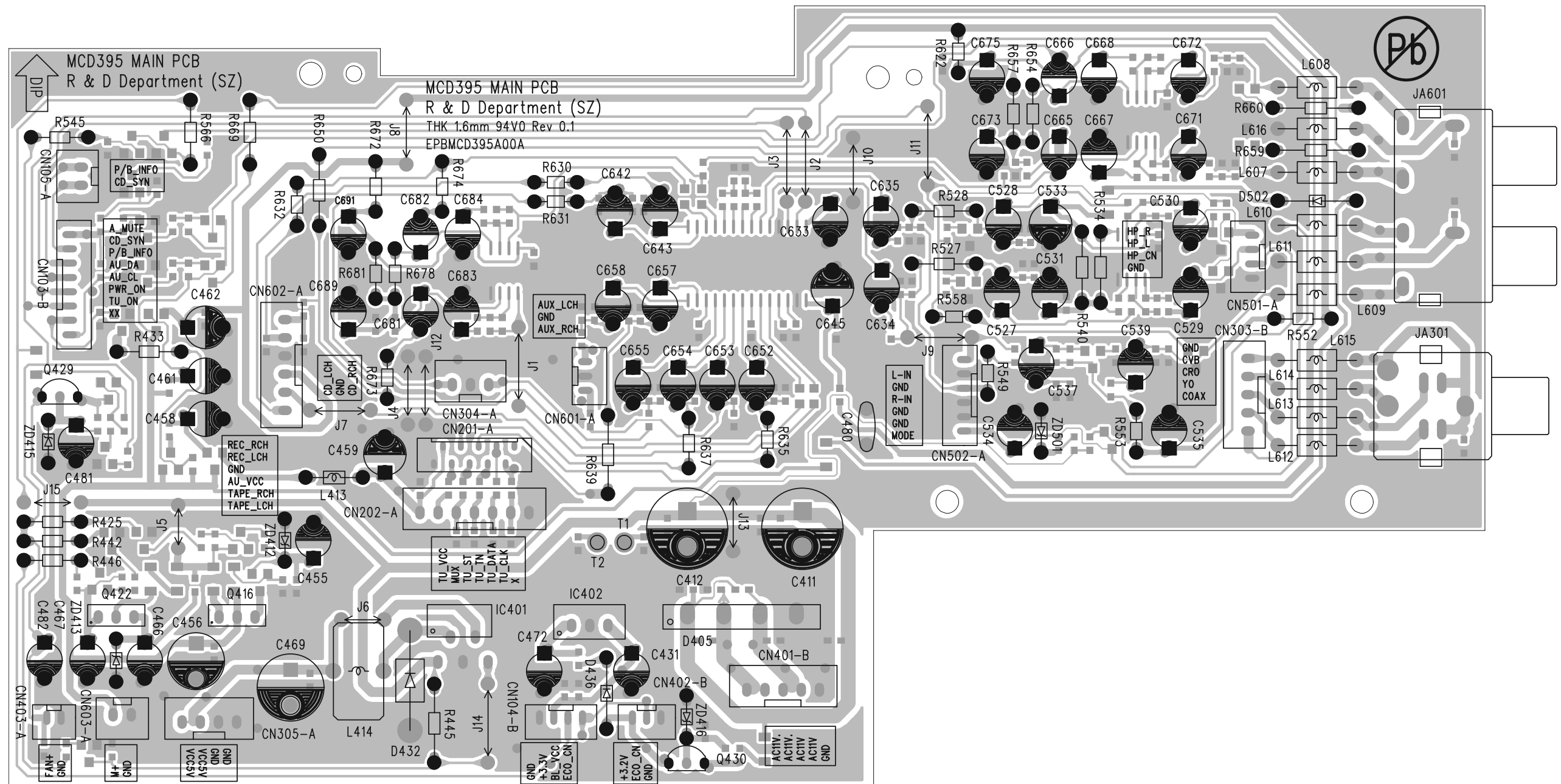

CIRCUIT DIAGRAM - HEADPHONE BOARD

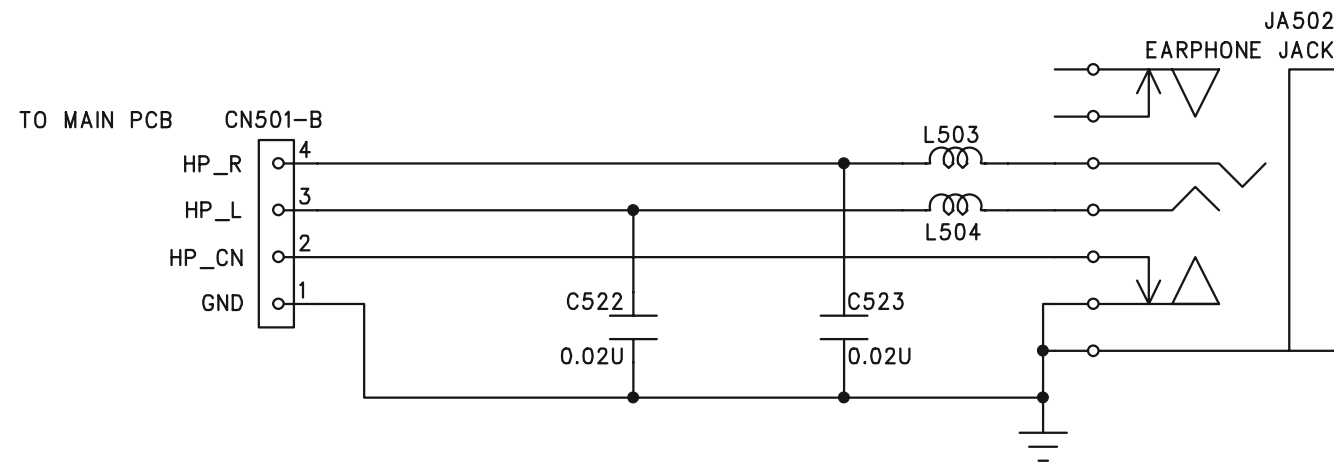

LAYOUT DIAGRAM - HEADPHONE BOARD

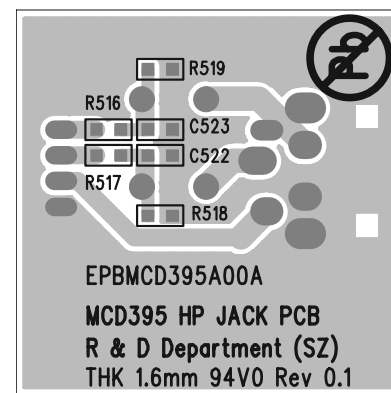
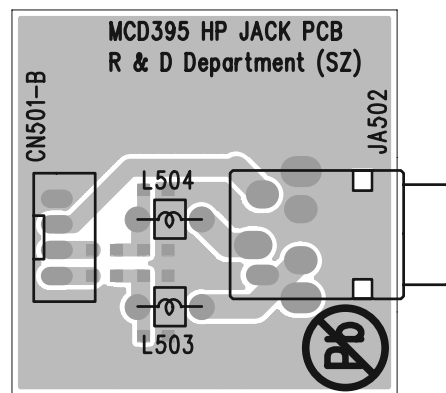

CIRCUIT DIAGRAM - AUX JACK BOARD

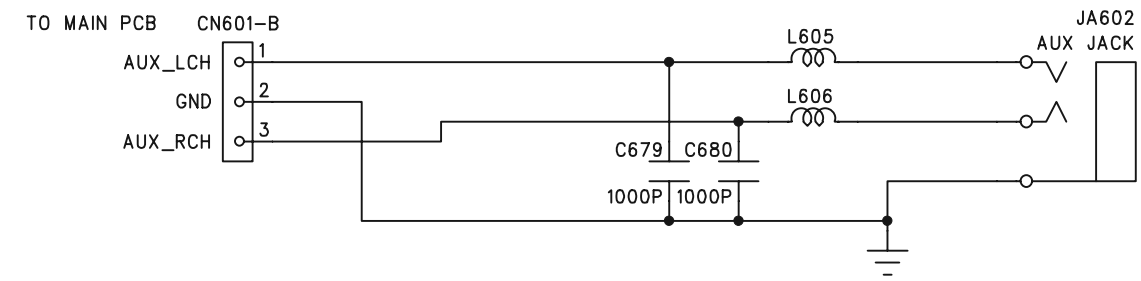

LAYOUT DIAGRAM - AUX JACK BOARD

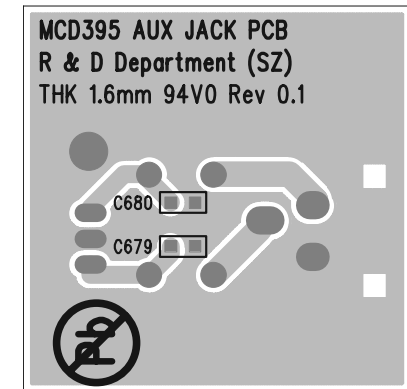
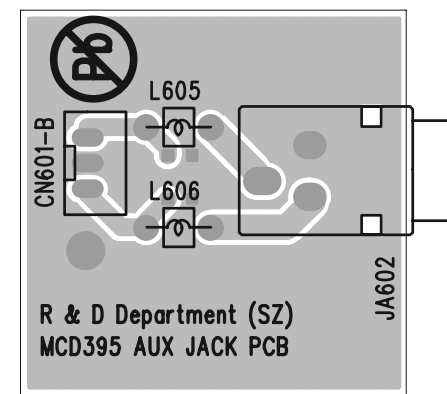

CIRCUIT DIAGRAM - USB JACK BOARD

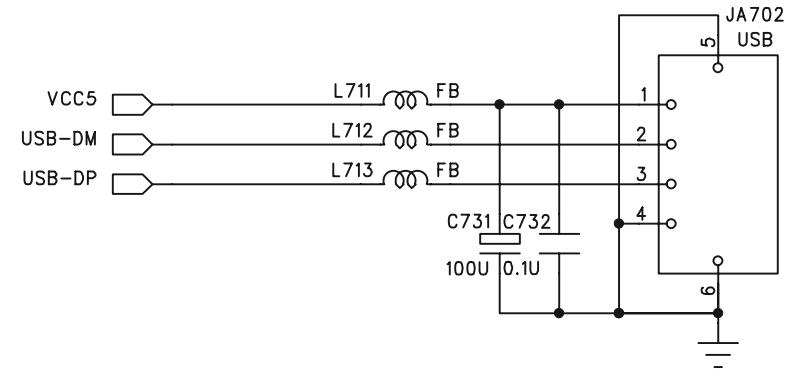
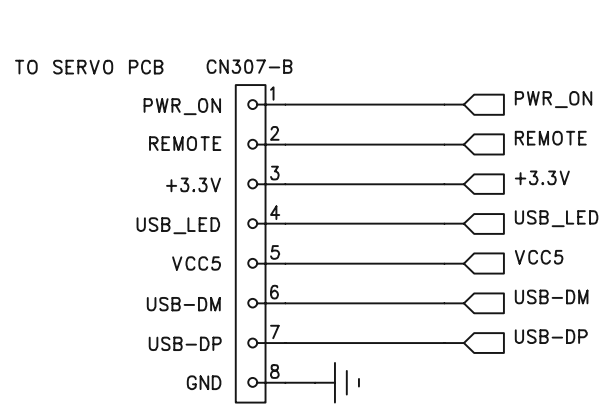

LAYOUT DIAGRAM - USB JACK BOARD

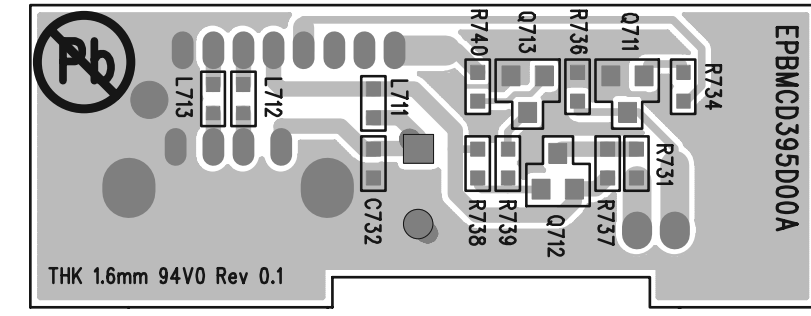
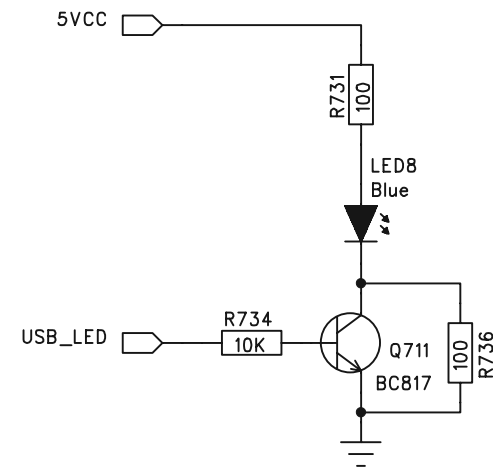
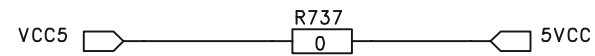
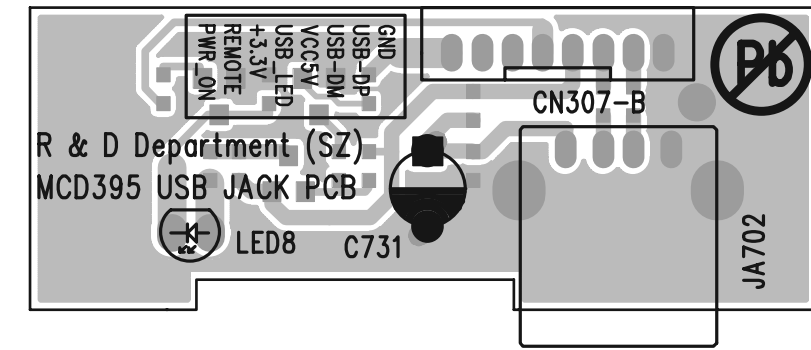

CIRCUIT DIAGRAM - DVD MPEG BOARD

MPEG is not repaired, diagram for reference only.

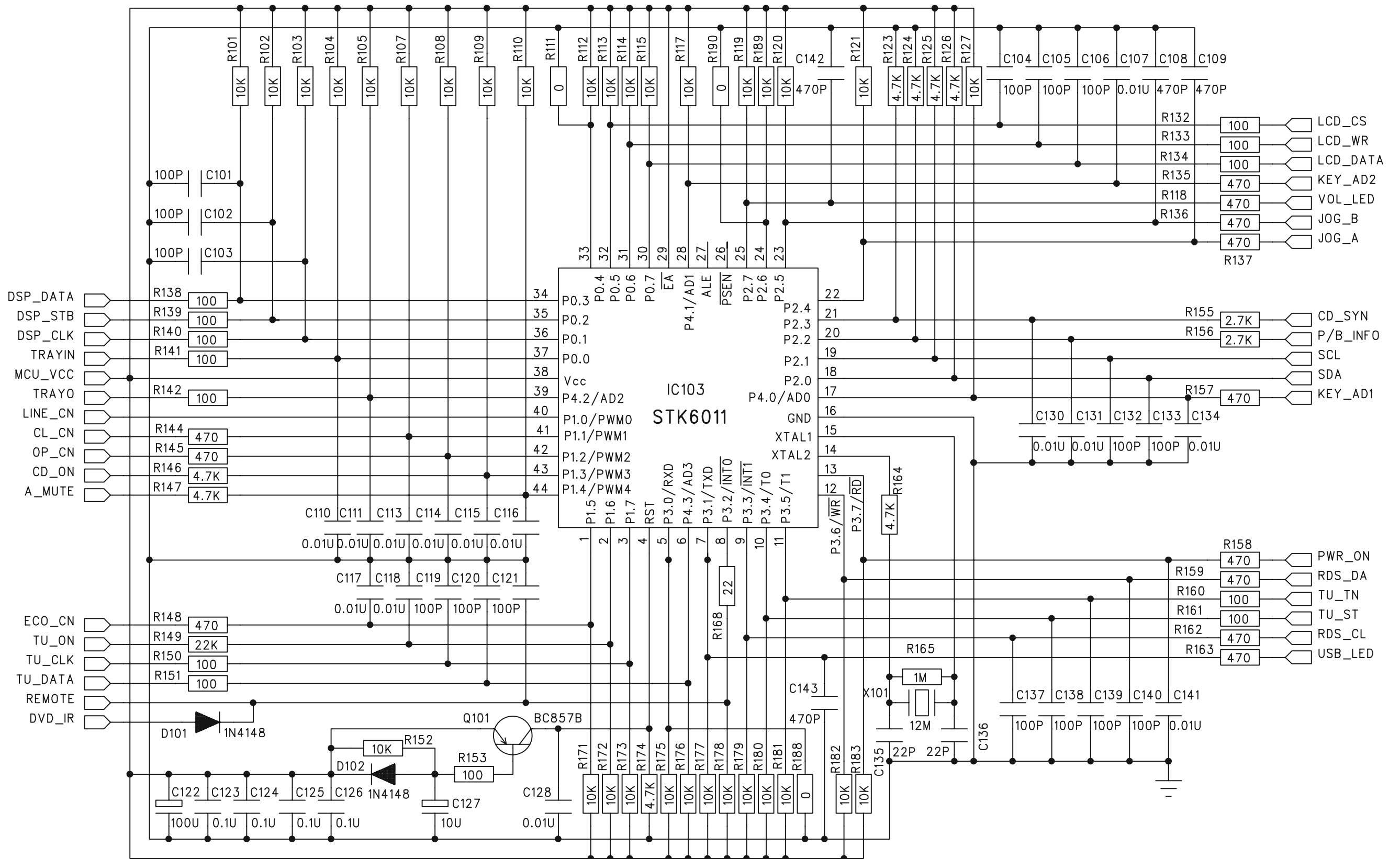

CIRCUIT DIAGRAM - DVD MPEG BOARD
MPEG is not repaired, diagram for reference only.

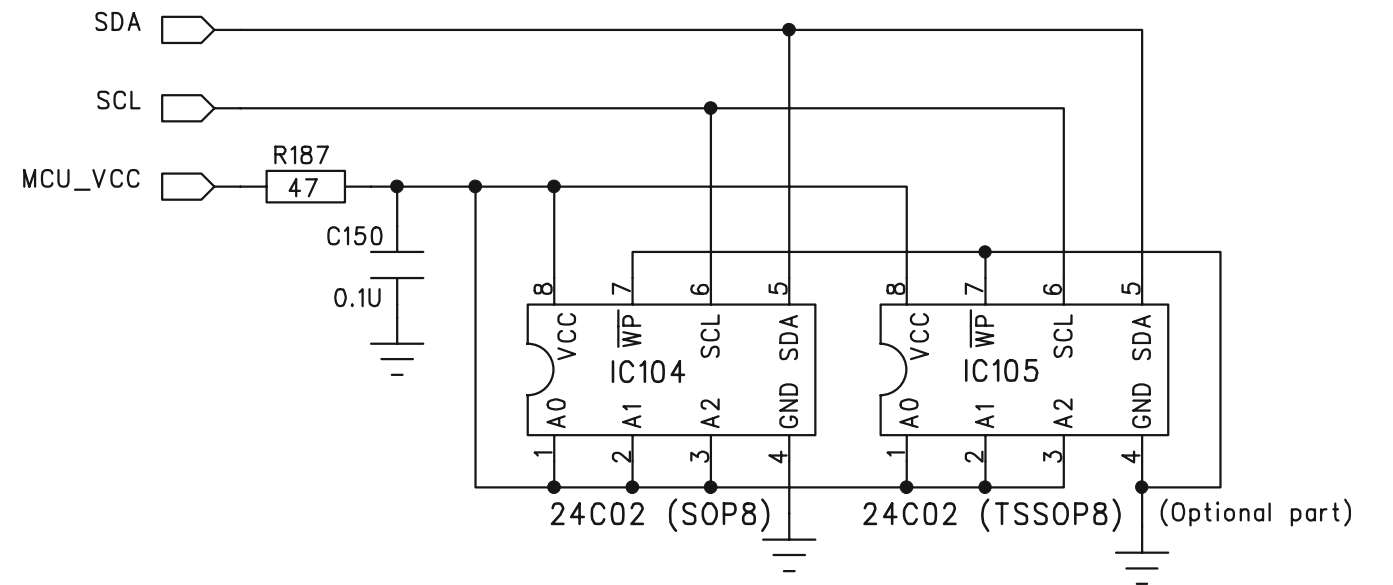
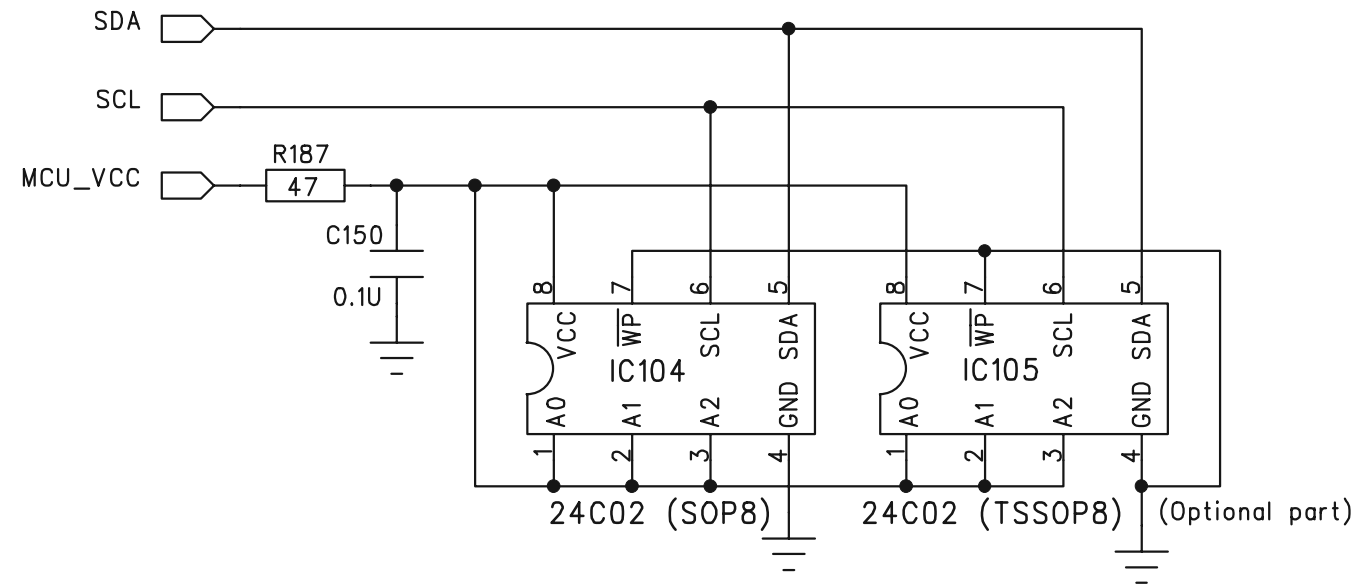
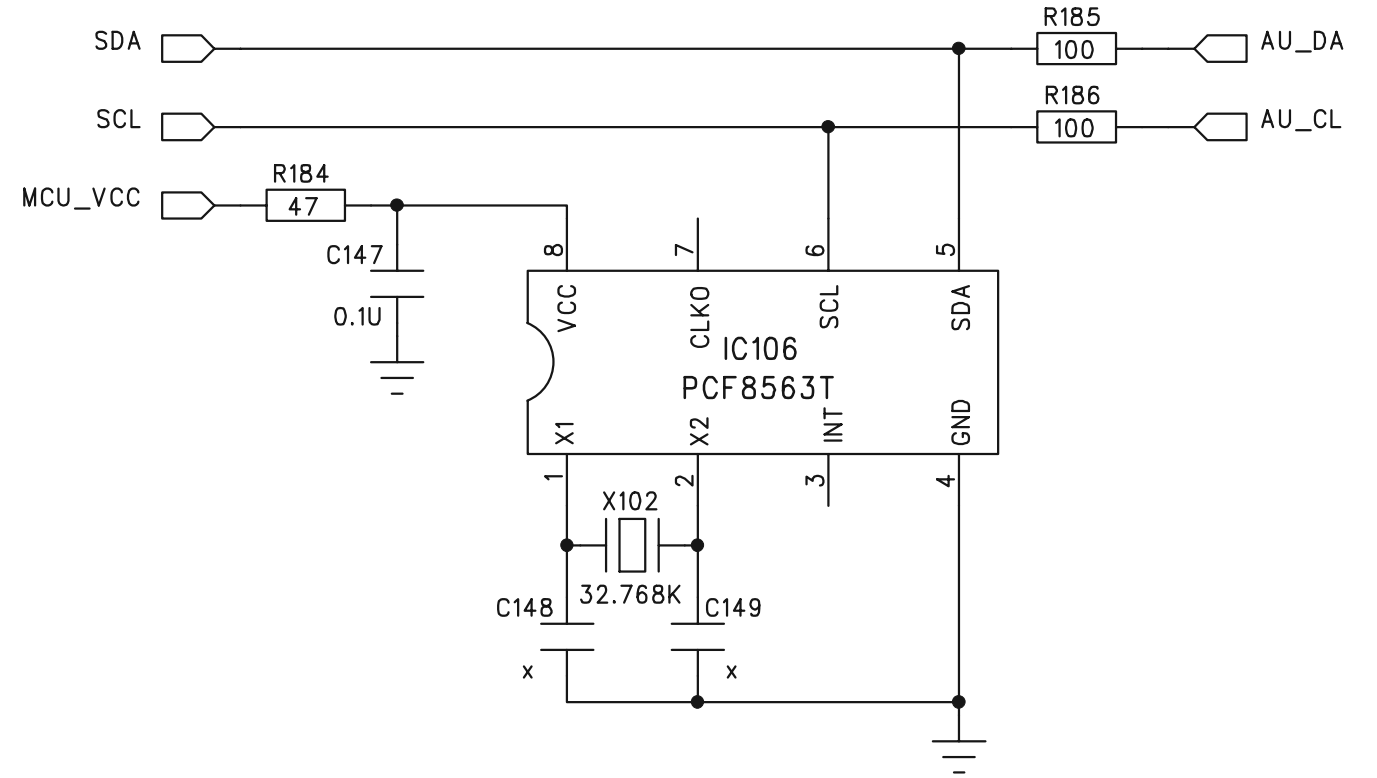
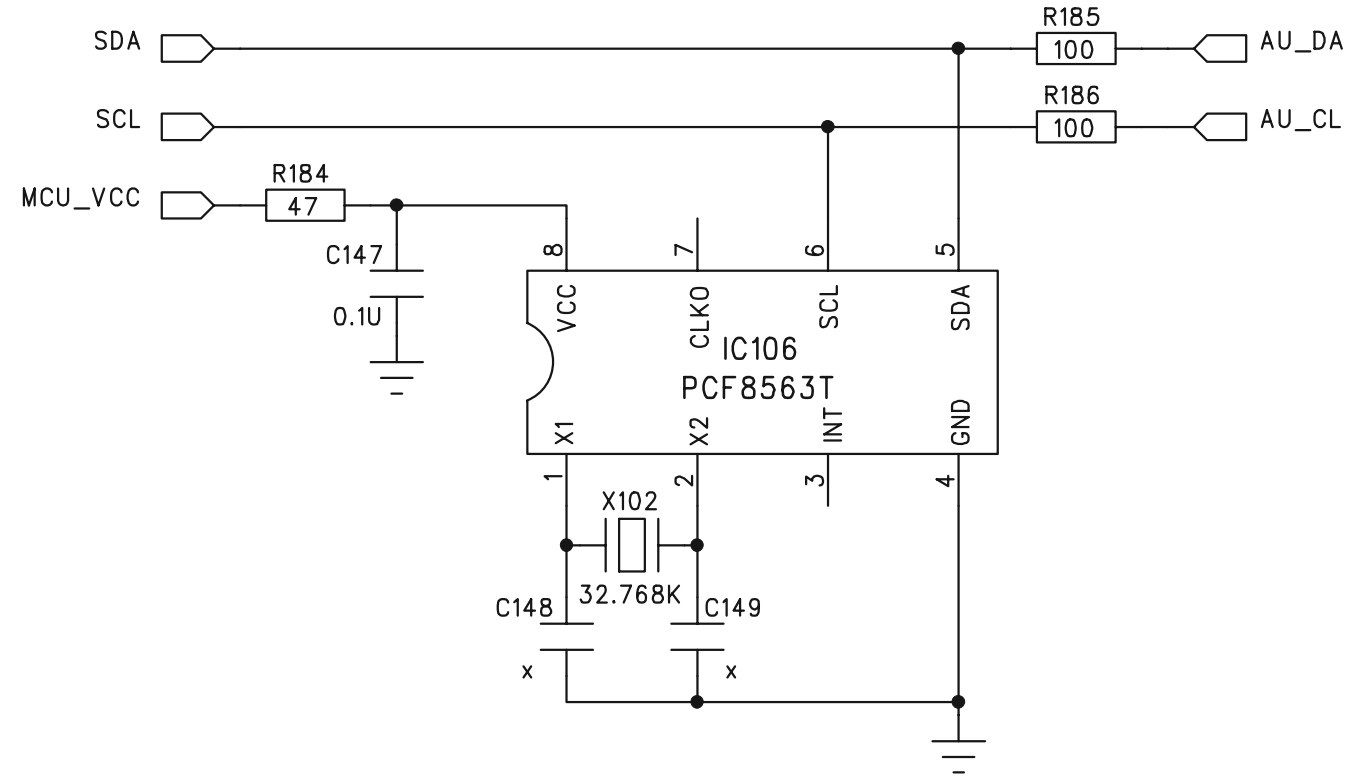

CIRCUIT DIAGRAM - DVD MPEG BOARD

MPEG is not repaired, diagram for reference only.

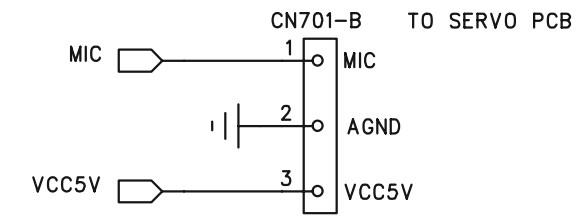
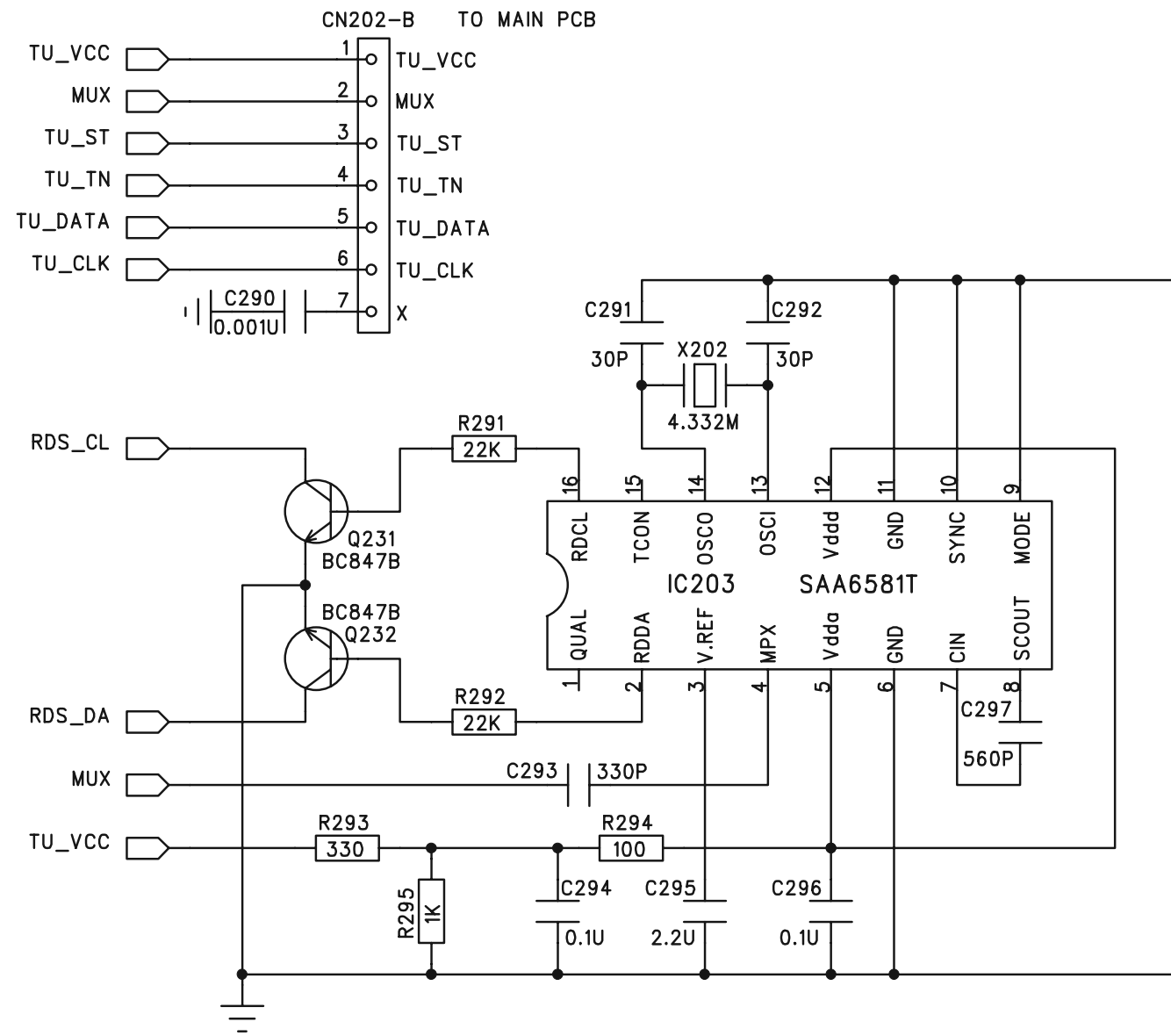

CIRCUIT DIAGRAM - DVD MPEG BOARD

MPEG is not repaired, diagram for reference only.

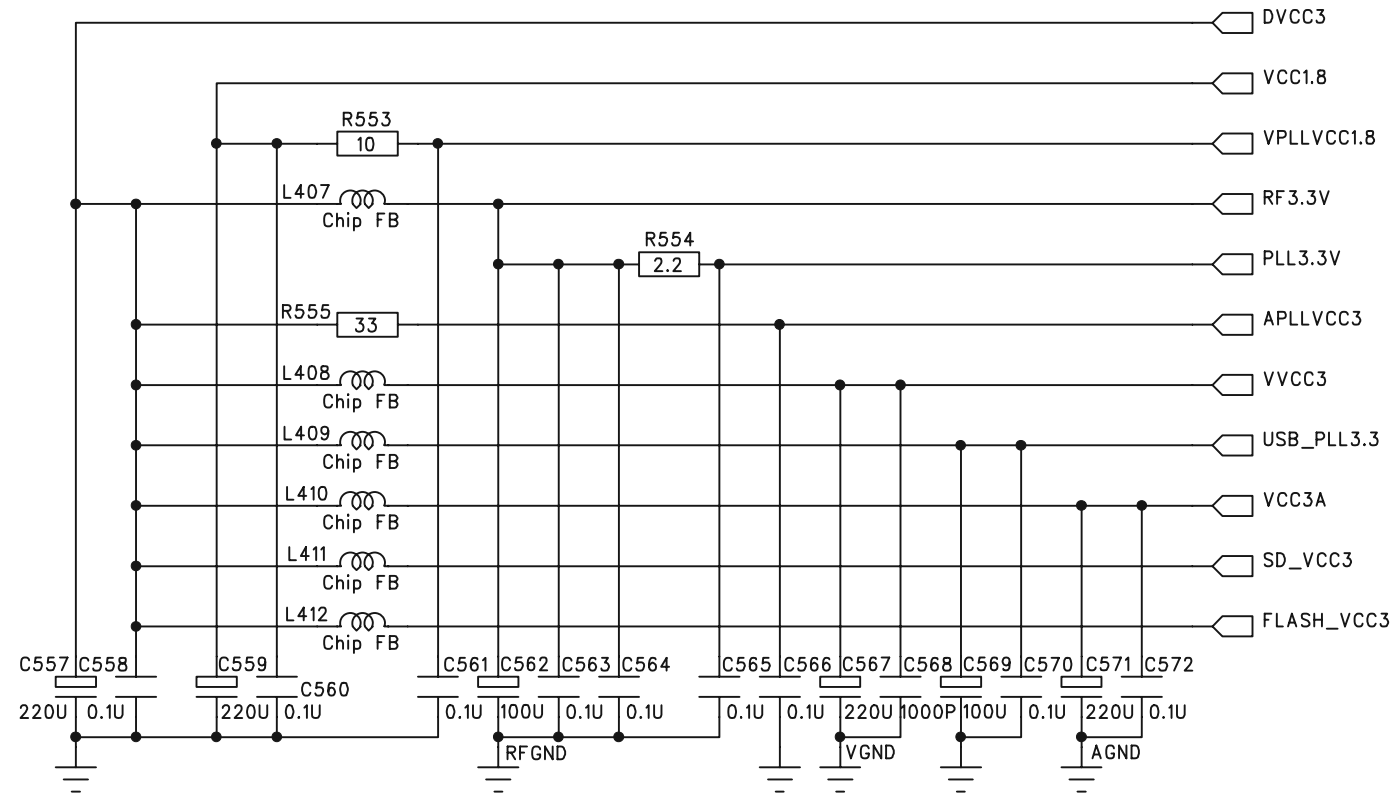
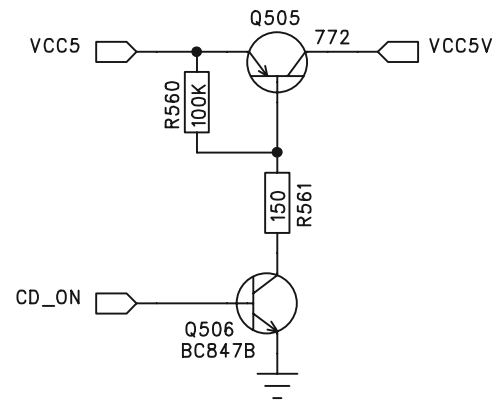
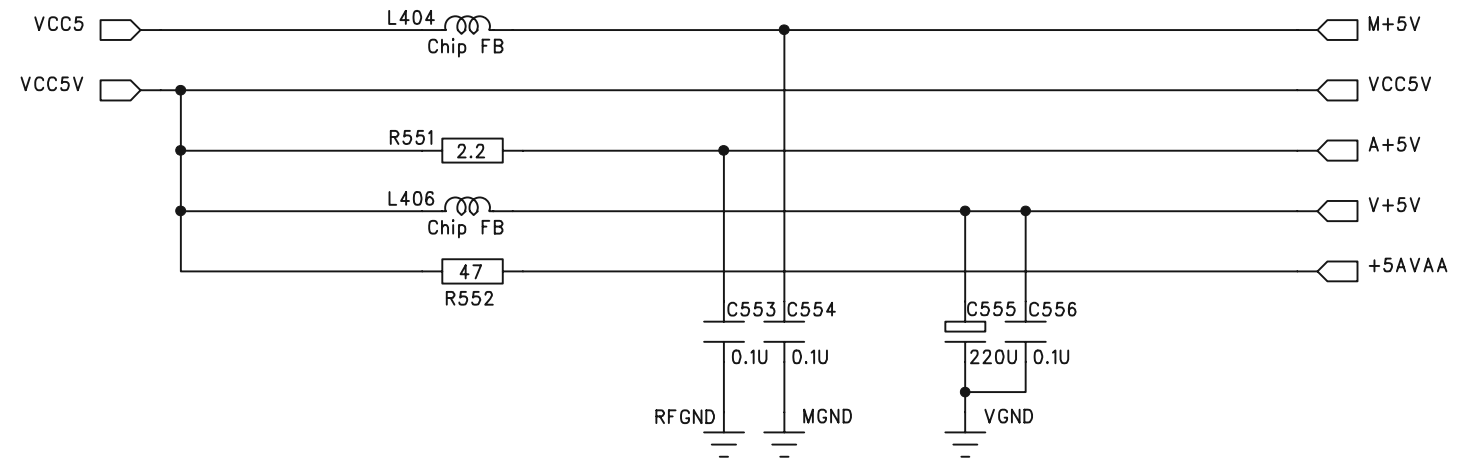
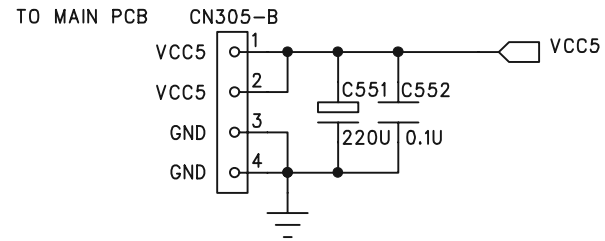

CIRCUIT DIAGRAM - DVD MPEG BOARD
 MPEG is not repaired, diagram for reference only.

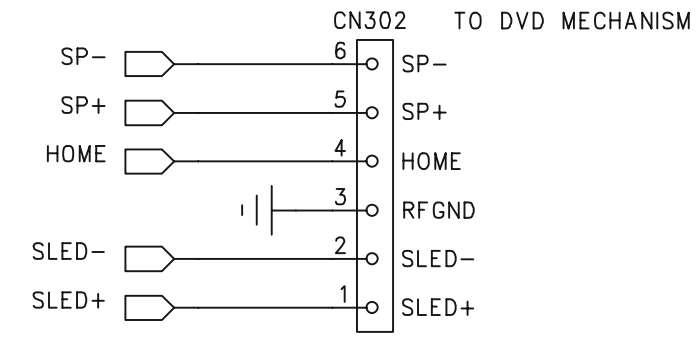
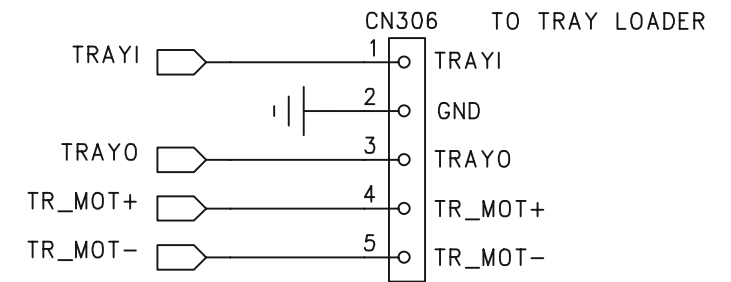
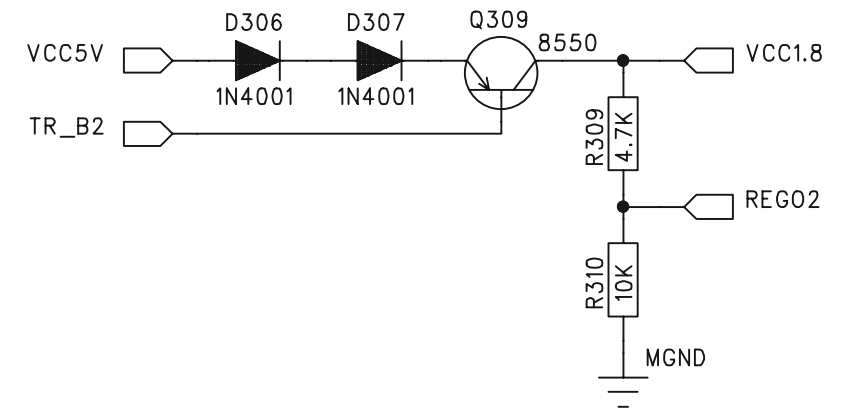
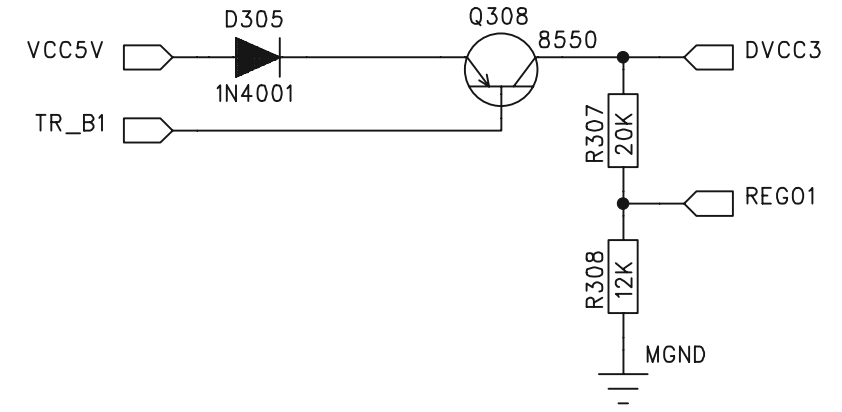
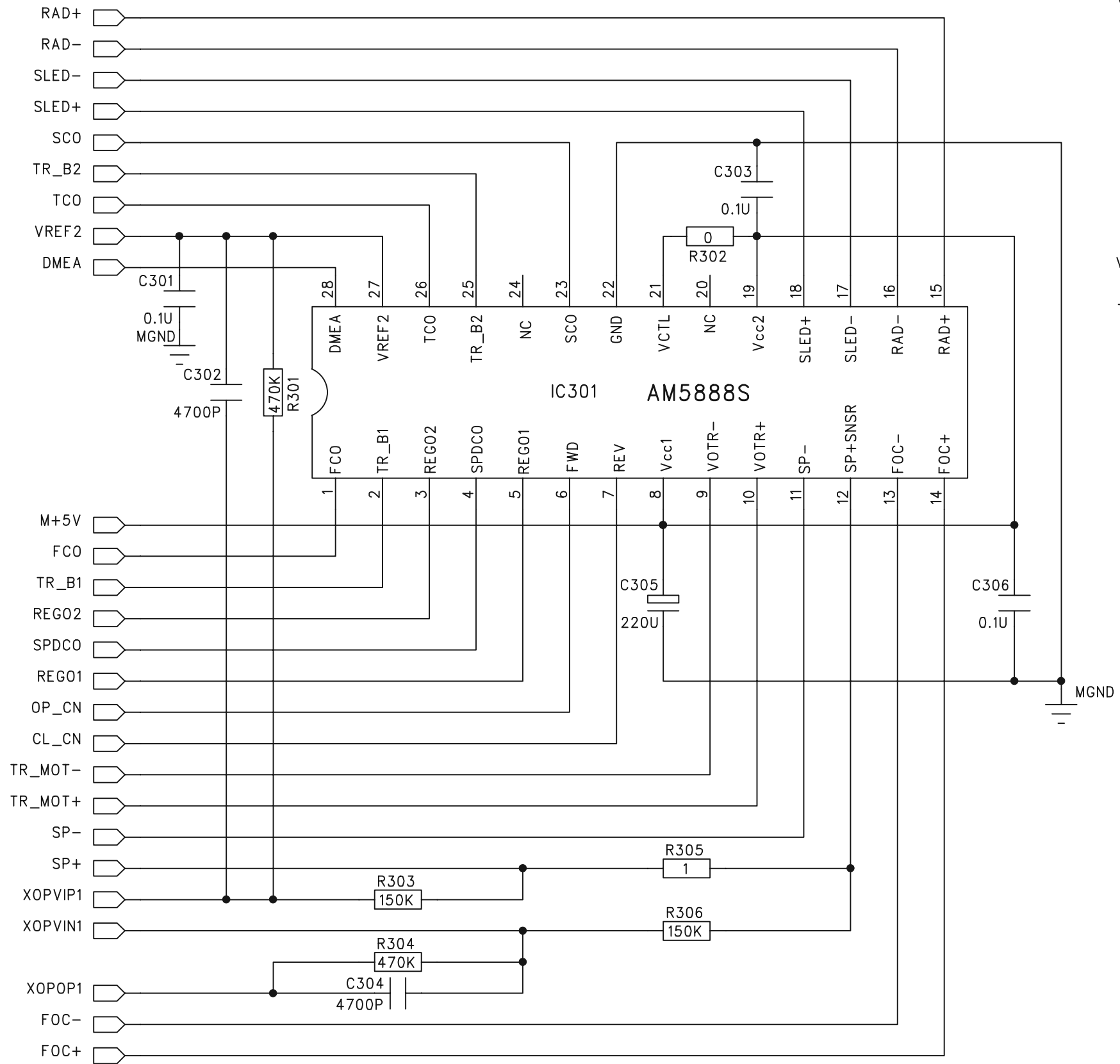

CIRCUIT DIAGRAM - DVD MPEG BOARD

MPEG is not repaired, diagram for reference only.

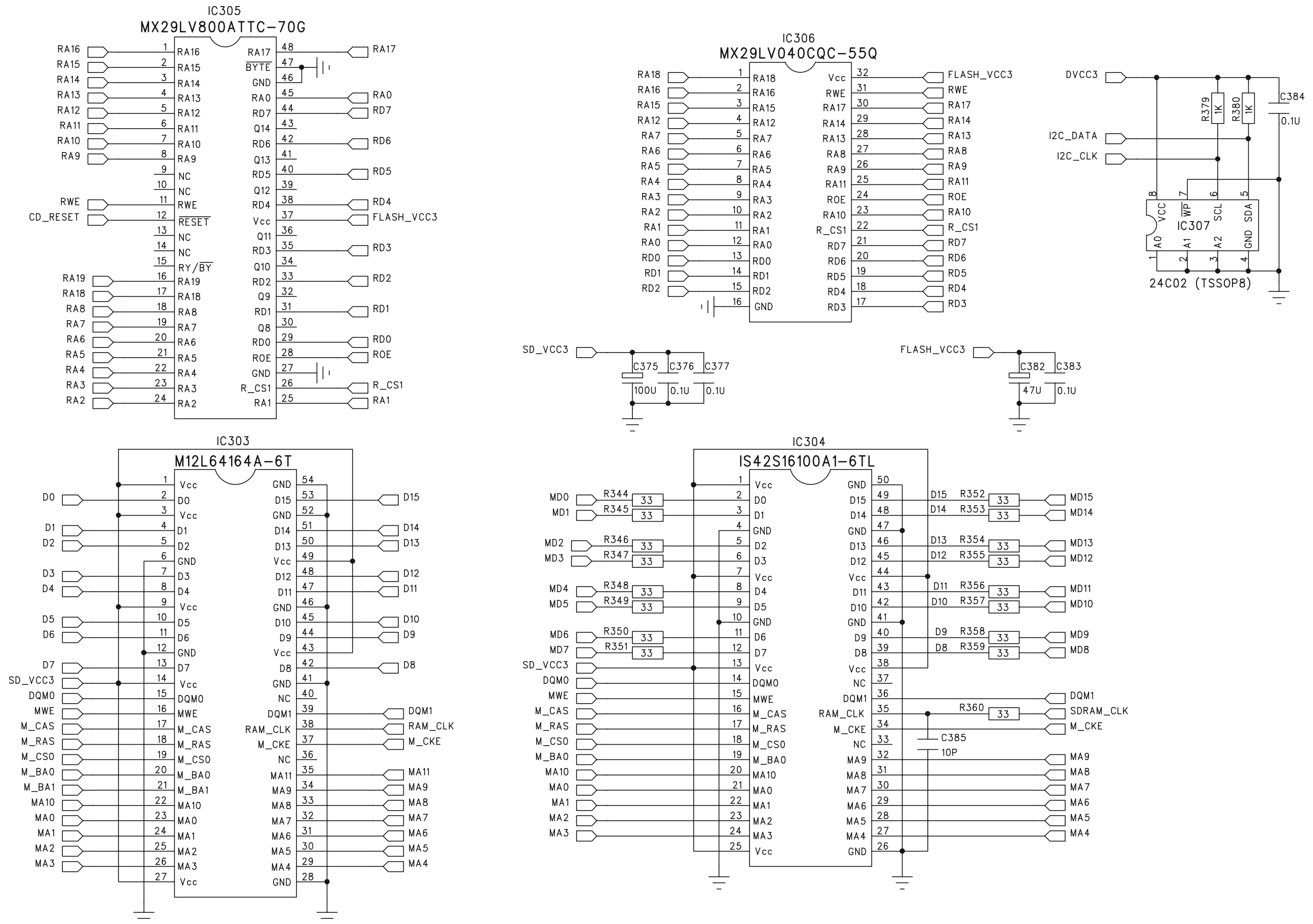

CIRCUIT DIAGRAM - DVD MPEG BOARD
 MPEG is not repaired, diagram for reference only.

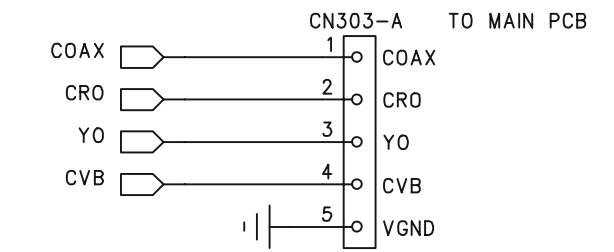
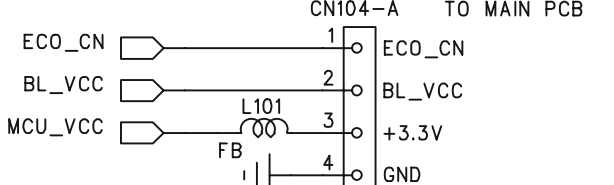
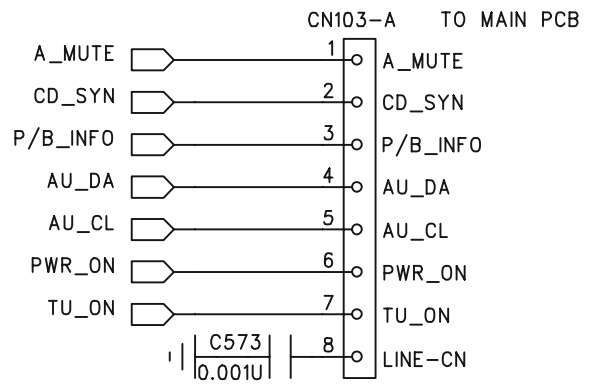
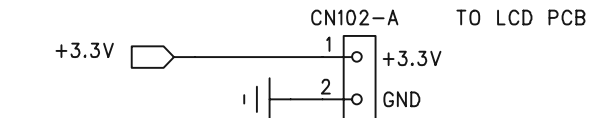
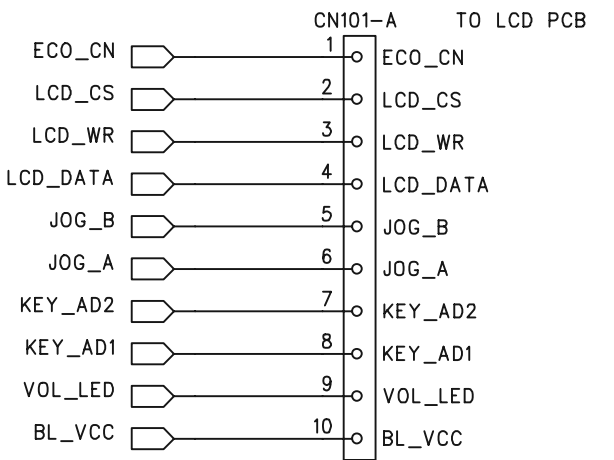
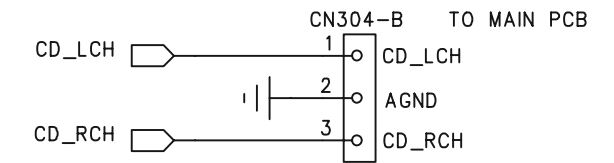
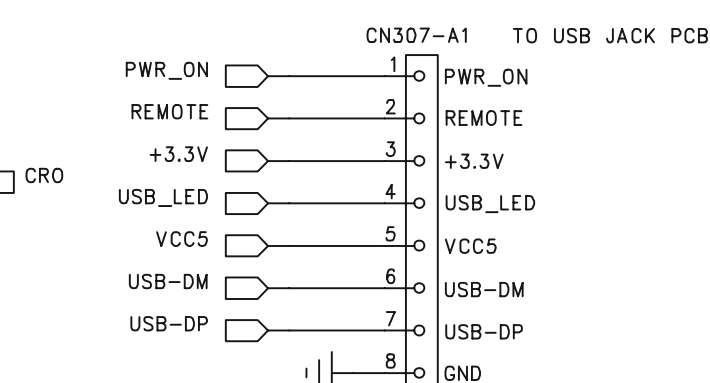
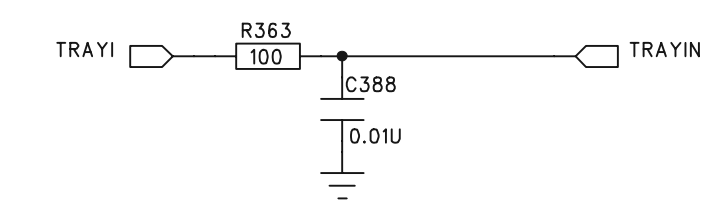
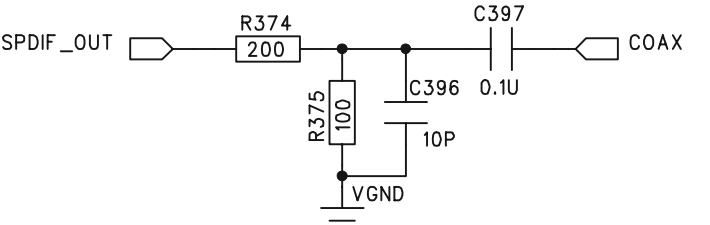
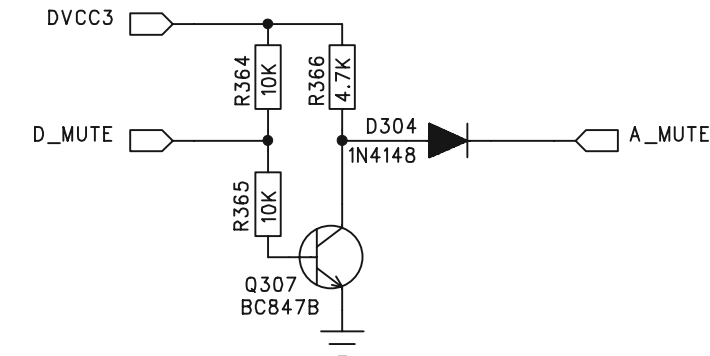
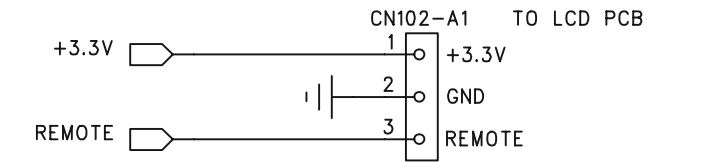
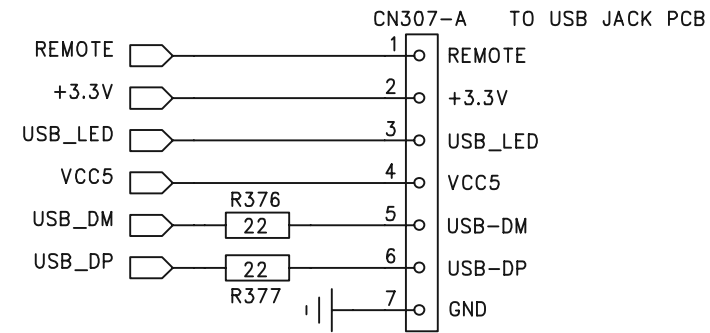
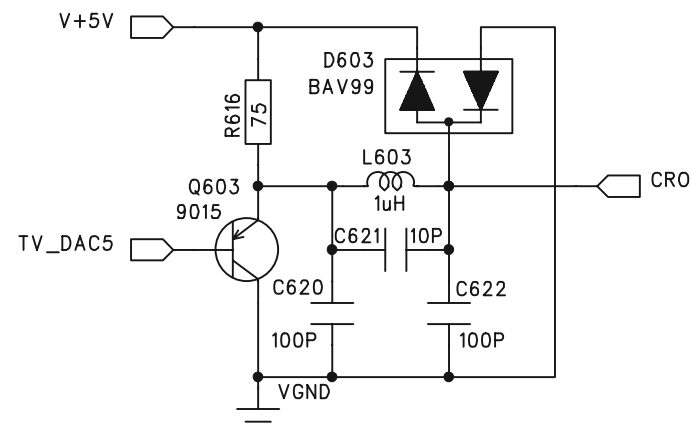
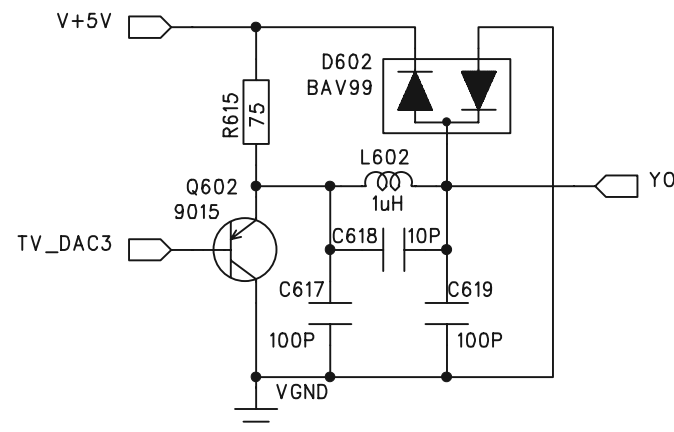
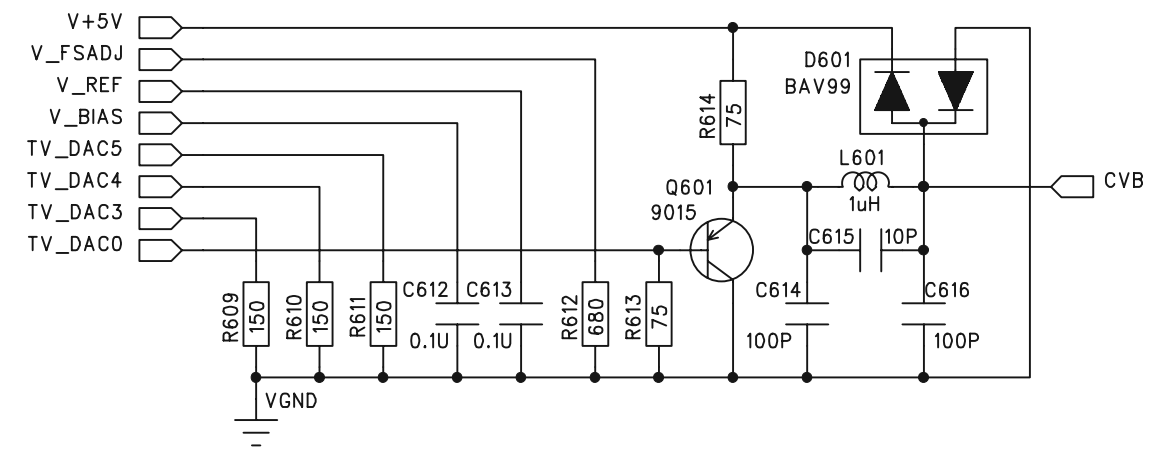
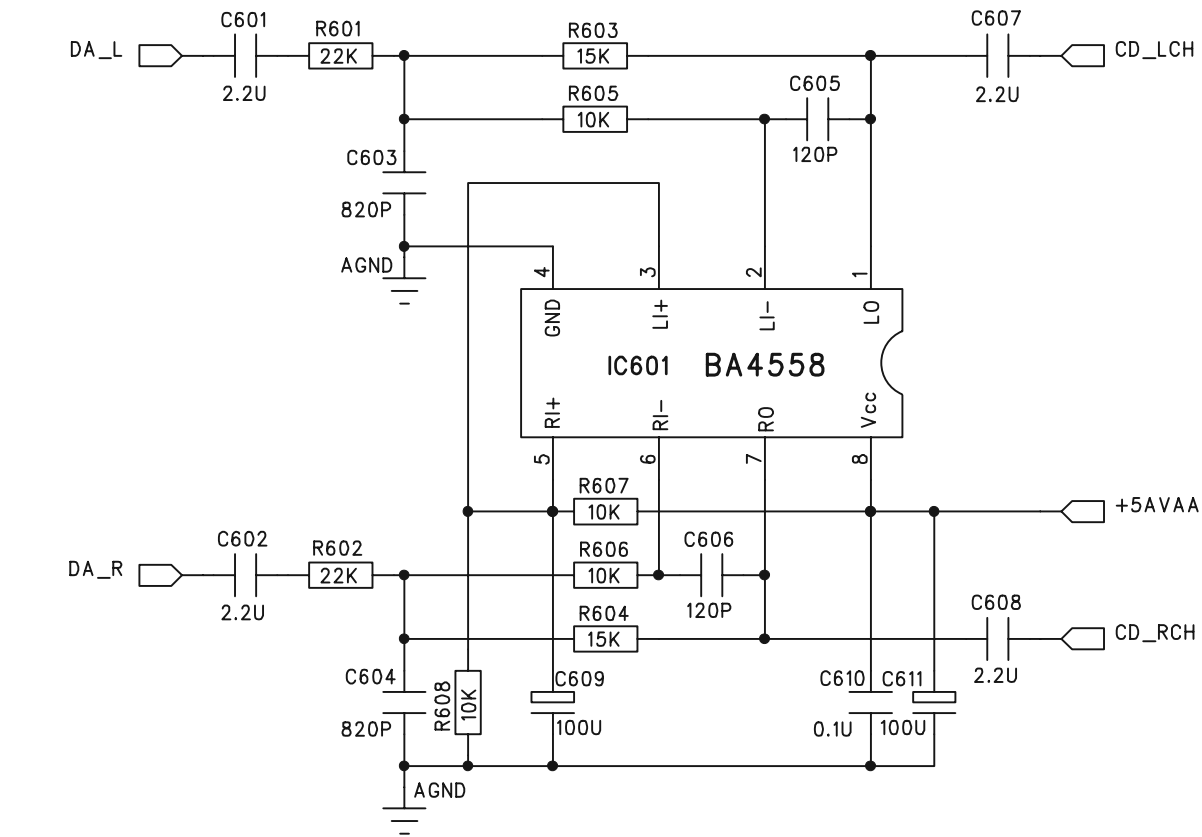

LAYOUT DIAGRAM - DVD MPEG BOARD
MPEG is not repaired, diagram for reference only.

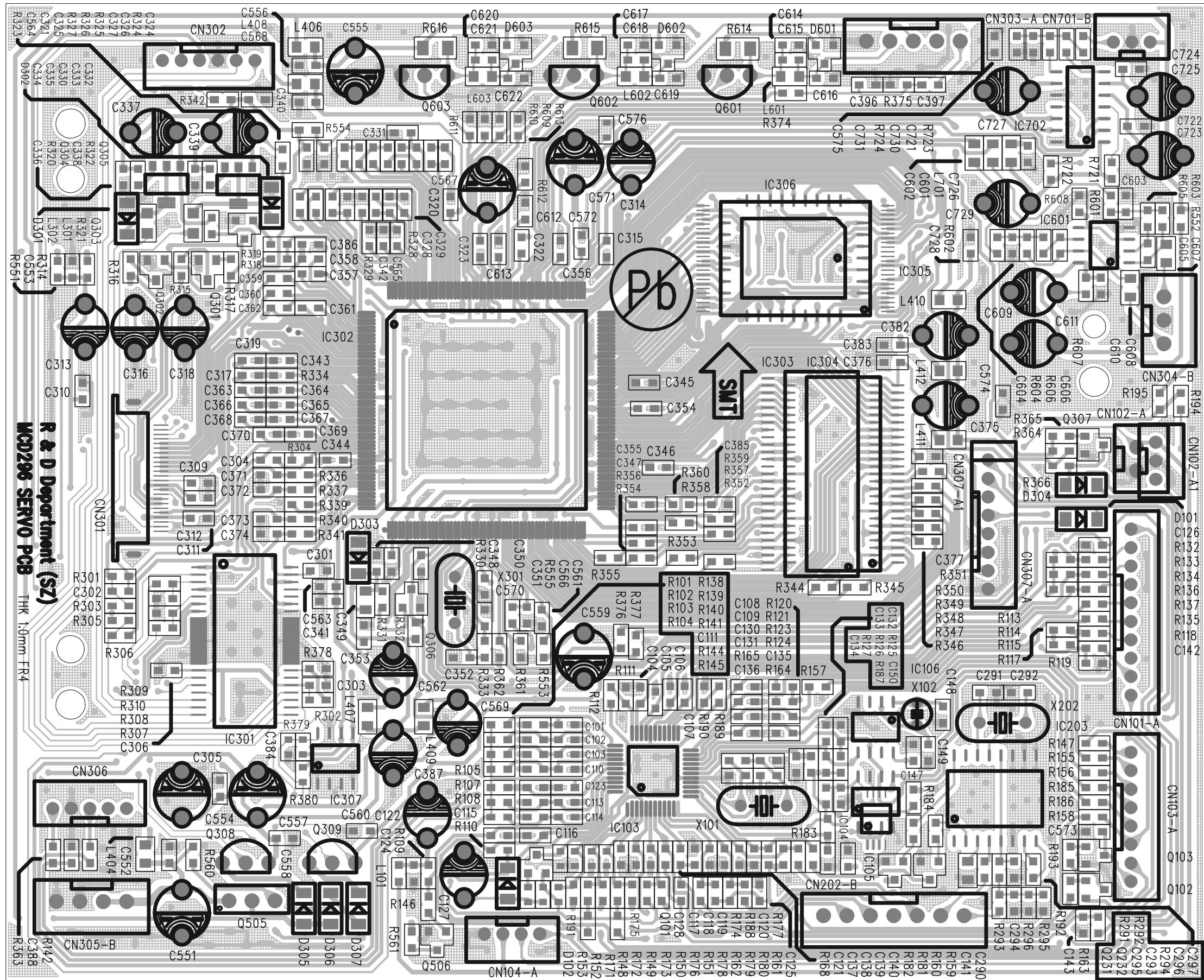

LAYOUT DIAGRAM - DVD MPEG BOARD

MPEG is not repaired, diagram for reference only.

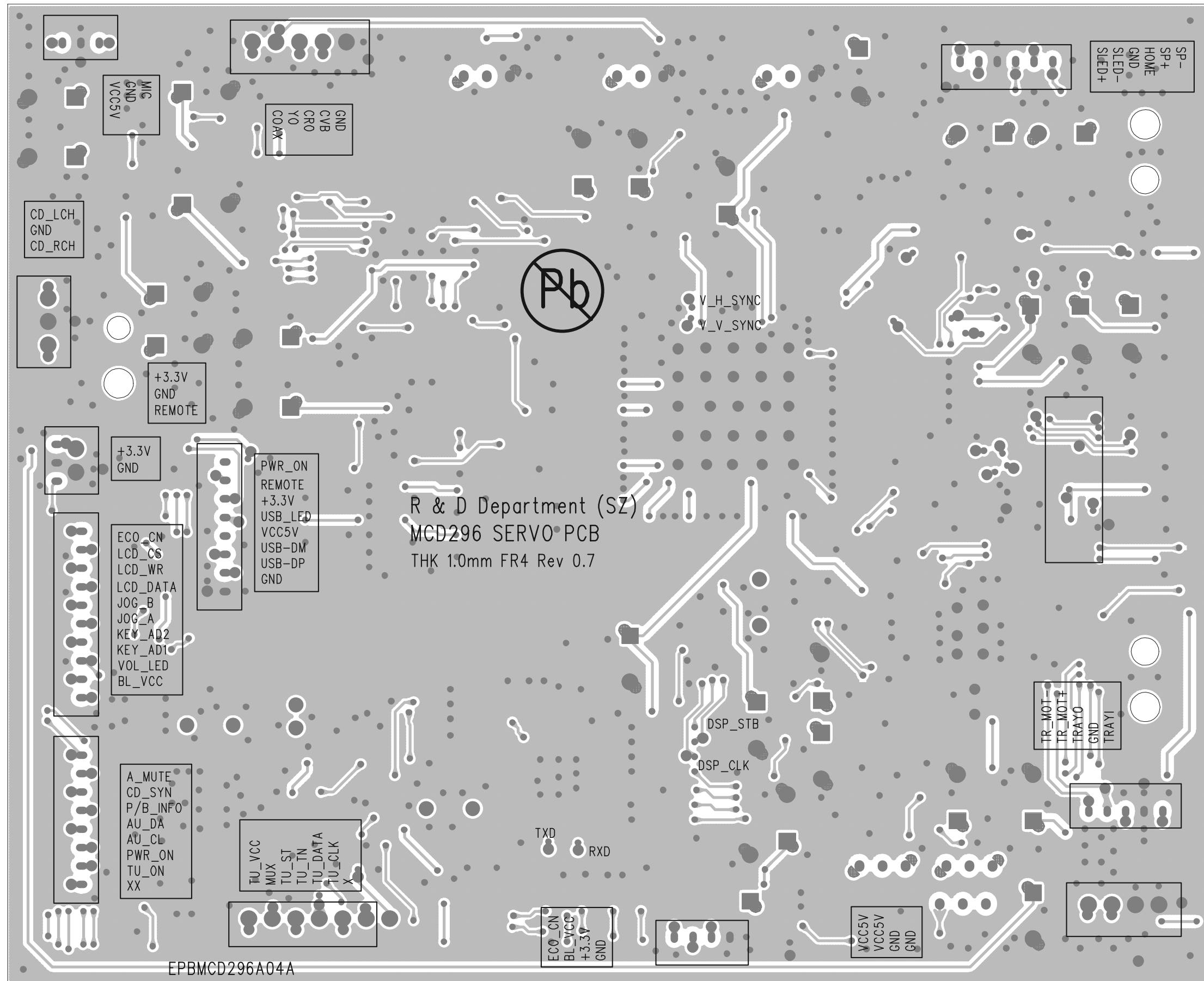

SET MECHANICAL EXPLODED VIEW

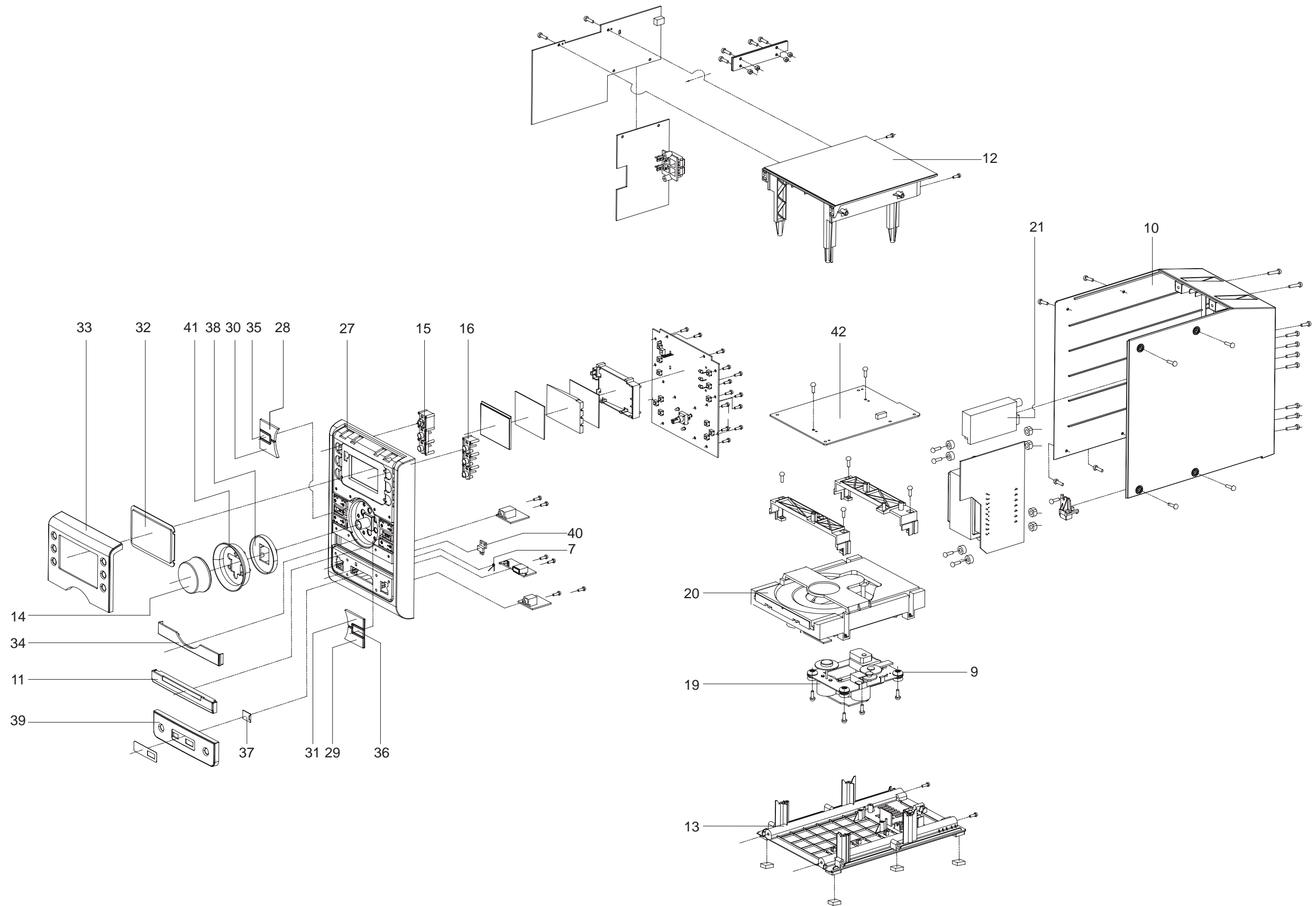

MECHANICAL & ACCESSORIES PARTS LIST

7	996510012846	USB DOOR SPRING
8	996510001074	CD SPRING DIM:0.5MM
9	996510000868	CD DAMPER PINK 658F
10	996510012847	REAR CABINET
11	996510012848	CD DOOR
12	996510012849	TOP CABINET
13	996510012850	BOTTOM CABINET
14	996510012851	VOLUME KNOB
15	996510012852	CONTROL KNOB-TOP-LEFT
16	996510012853	CONTROL KNOB-TOP-RIGHT
17	996510012854	POWER LIGHT GUIDE
18	△ 996510001450	VDE AC CORD 1.72M
19	996510001451	DVD MECHANISM SONY
20	996510001452	DVD TRAY LOADER WXD-8213
21	996510012855	FM TUNER MODULE FOR DC199A/12
22	996510001453	FFC CABLE 24P
23	996510010781	FFC CABLE 10P L=330MM
24	996510001456	RCA WIRE 1500MM BLACK WIRE
25	996510012813	REMOTE CONTROL FOR MCD395
26	996510005595	PIG TAIL ANTENNA WIRE BLACK
27	996510012814	FRONT CABINET
28	996510012815	CONTROL KNOB - FB
29	996510012816	CONTROL KNOB - FF
30	996510012817	CONTROL KNOB - PRESETS(LEFT)
31	996510012818	CONTROL KNOB - PRESETS(RIGHT)
32	996510012819	DISPLAY LENS
33	996510012820	DECORATION LENS TOP PANEL
34	996510012821	DECORATION LENS MIDDLE PANEL
35	996510012822	CONTROL KNOB - PLAY/PAUSE
36	996510012823	CONTROL KNOB - STOP
37	996510012824	USB DOOR
38	996510012825	DECORATION RING
39	996510012826	DECORATION LENS BOTTOM PANEL
40	996510012827	USB LIGHT GUIDE
41	996510012828	VOLUME KNOB LIGHT GUIDE
42	996510036681	SERVO(MPEG) BOARD ASS'Y /58
42	996510036682	SERVO(MPEG) BOARD ASS'Y /12

Note: Only these parts mentioned in the list are normal service parts.

ELECTRICAL PARTS LIST - RECTIFIER BOARD

FUSE1	△ 994000003224	FUSE 6.3A 250V
FUSE2	△ 994000003224	FUSE 6.3A 250V
FUSE3	△ 996510000389	FUSE 2.5A 250V
K401	994000001448	9V DC RELAY 10A ME-7-009-HL
L401	994000003226	AC LINE FILTER 400UH -30%
Q401	996510005008	TRANSISTOR SS8050D TO-92
T401	△ 996510012812	TRASFO EI-76 230V/50Hz
T402	△ 996510001418	TRANSFORMER STANDBY

Note: Only these parts mentioned in the list are normal service parts.

**ELECTRICAL PARTS LIST - SERVO (MPEG) BOARD
(ONLY FOR REFERENCE)**

D305	996510010756	RECTIFIER DIODE SM4001S SM-2 X102	996510012842	X'TAL 32.768KHZ 12.5PF
D306	996510010756	RECTIFIER DIODE SM4001S SM-2 X202	994000003209	X'TAL 4.332MHZ HC-49/S
D307	996510010756	RECTIFIER DIODE SM4001S SM-2 X301	996510010755	X'TAL 27MHZ 20PF +/-20PPM
D601	996510010757	SWITCHING DIODE BAV99L		
D602	996510010757	SWITCHING DIODE BAV99L		
D603	996510010757	SWITCHING DIODE BAV99L		
IC103	996510019969	IC STK6011P9-3V PROGRAMMED		
IC104	996510010763	IC AT24C02BN-SH-T		
IC106	996510010764	IC PCF8563T SO8		
IC203	994000003215	RDS IC SAA6581T		
IC301	996510010762	IC AM5888S HSOP28		
IC302	996510010761	IC MPEG SPHE8281D		
IC303	996510010760	IC SDRAM 64M M12L64164A-7TG		
IC305	996510012843	IC EN29LV800AB-70TCCP PROGRAM		
IC307	996510010763	IC AT24C02BN-SH-T		
IC601	996510001055	IC BA4558 SOP8		
L101	996510001060	FERRITE BEAN SBK160808T-601Y-S		
L601	996510012845	INDUCTOR 1uH TL201209-1R0K-LF		
L602	996510012845	INDUCTOR 1uH TL201209-1R0K-LF		
L603	996510012845	INDUCTOR 1uH TL201209-1R0K-LF		
Q301	996510010766	TRANSISTOR (MOSFET) 2SK3018		
Q302	996510010766	TRANSISTOR (MOSFET) 2SK3018		
Q304	996510010765	TRANSISTOR 2SB1132R		
Q305	996510010765	TRANSISTOR 2SB1132R		
Q308	994000003206	TRANSISTOR 8550D		
Q309	994000003206	TRANSISTOR 8550D		
Q505	996510001414	TRANSISTOR KTB772		
Q601	994000003206	TRANSISTOR 8550D		
Q602	994000003206	TRANSISTOR 8550D		
Q603	994000003206	TRANSISTOR 8550D		
X101	996510005000	X'TAL 12MHZ 49S 20PF +/-20PPM		

REVISION LIST

1.0 Manual 3141 785 32620

Initial Service Manual released.

1.1 Manual 3141 785 32621

In this version, on Page 11-2 Mechanical & Accessories Parts List updated,
and Page 12-2 Electrical Parts List updated.

42	996510019968	SERVO(MPEG) BOARD ASS'Y /12 (WAS 996520033376)
IC103	996510019969	IC STK6011P9-3V PROGRAMMED (WAS 996510012844)

1.2 Manual 3141 785 32622

In this version, on Page 11-2 Mechanical & Accessories Parts List updated,

42	996510036681	SERVO(MPEG) BOARD ASS'Y /58 (WAS 996510015794)
42	996510036682	SERVO(MPEG) BOARD ASS'Y /12 (WAS 996510019968)

Remark: 996510036681 is fully compatible with 996510015794.
996510036682 is fully compatible with 996510019968.