

NV11, 4Mx16 DDR, RGB, INTERNAL DVI-I, AGP.

PCI DEVICE ID 0X0=0X110 FOR NV11.

STRAPS: AGP4X, SIDEBAND DIS, FAST WRITE ENA, ADP BIOS, NORMAL PCIAD, 14.318MHZ
STRAP_RAM_TYPE [5:2]=1010.4MX16 DDR SDRAM

HISTORY REV. A00:

- 1) A00: Imported P0039-C00
- 2) A00: Changed FB Memory to 4Mx16 DDR Ram
- 3) A00: Added 2.5V Power Reg for DDR RAM
- 4) A00: Changed Strap resistors.

HISTORY REV. A01:

- Changed R212 to 110R value (RSET)

602-10044-0000-A01



NVIDIA

NVIDIA Corporation
3535 Monroe St
Santa Clara, CA 95051, USA

Size B	CAGE Code	DWG NO	Rev
Scale		Sheet	1 of 12

Saturday, March 09, 2002

{Item}\t{Quantity}\t{Reference}\t{Source Package}\t{Value}\t{Assembly}
{Assembly}\t{Source Package} {Value} {PN} {AVL1} {AVL2} {AVL3} {AVL4} {AVL5}

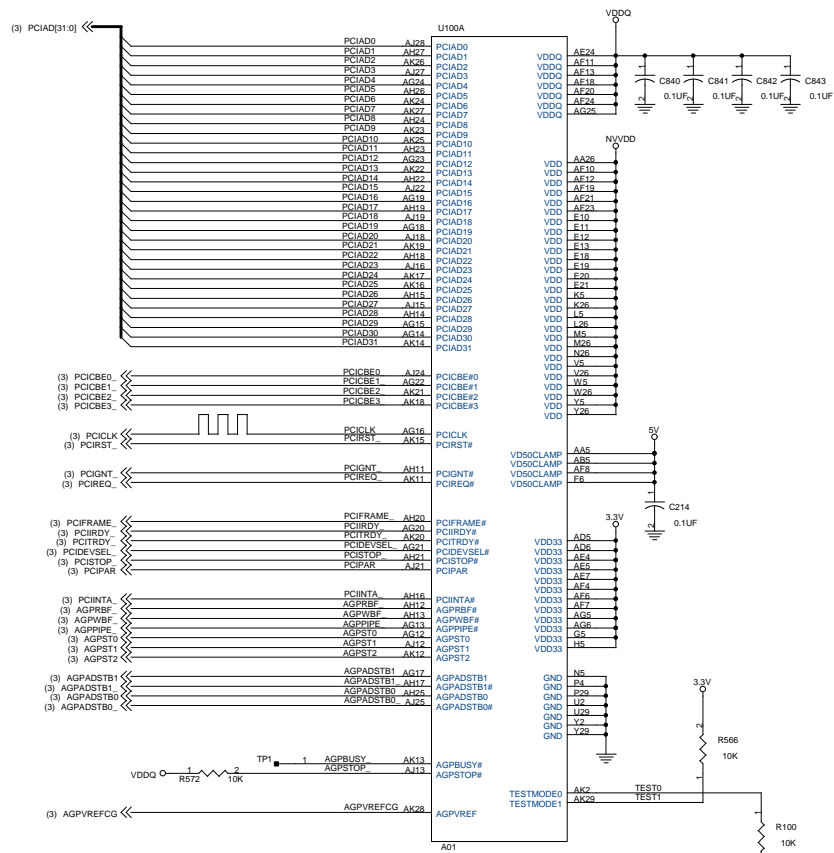

1a. NVXX HOST

	NVIDIA Corporation 3535 Monroe St Santa Clara, CA 95051, USA		
	Size	CAGE Code	DWG NO
Monday, March 11, 2002	Scale	Sheet	2 of 12

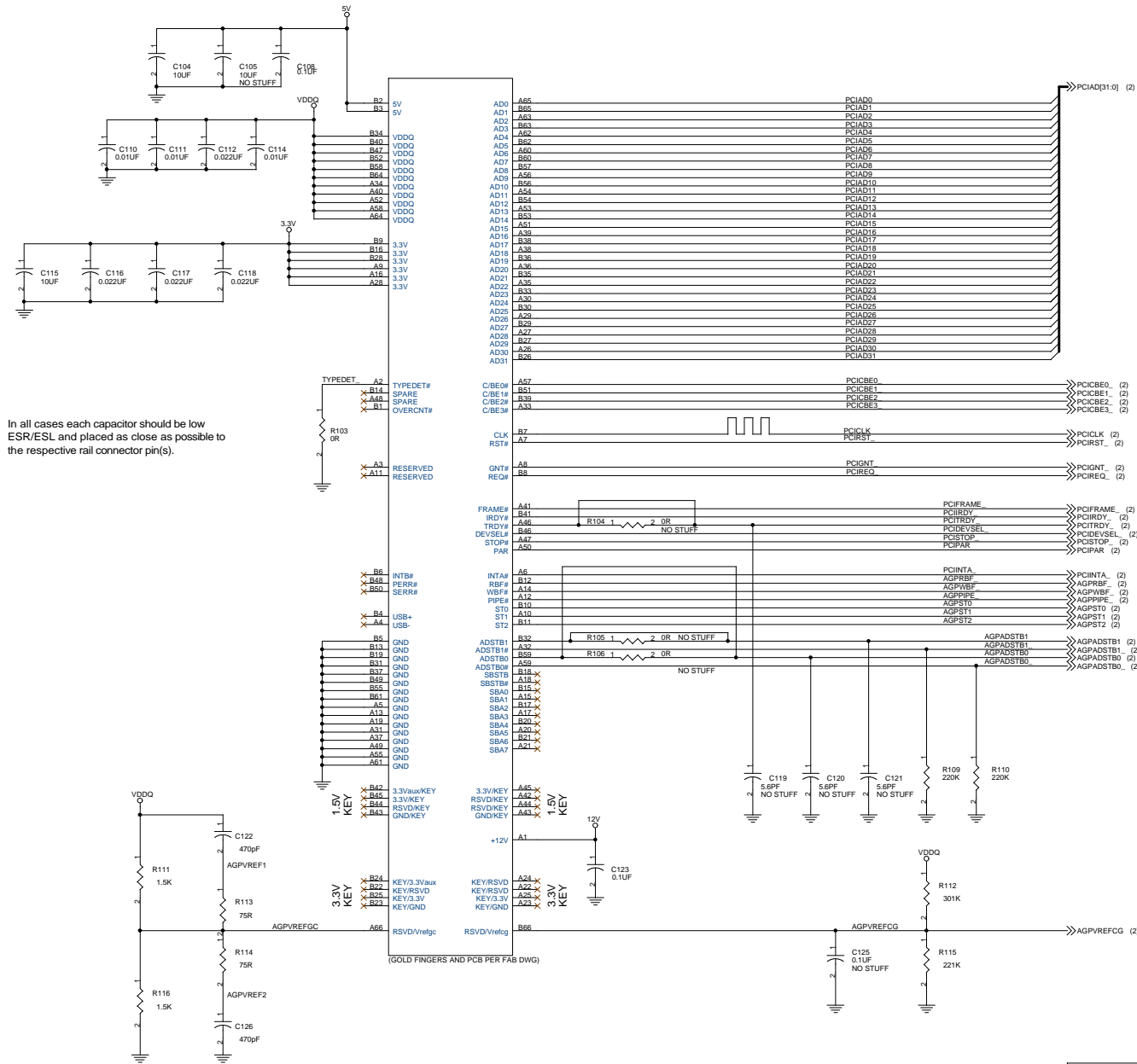

1b1. AGP I/O

		NVIDIA Corporation 3535 Monroe St Santa Clara, CA 95051, USA		
		Size C	CAGE Code	DWG NO
Monday, March 11, 2002		Scale	Sheet 3 of 12	

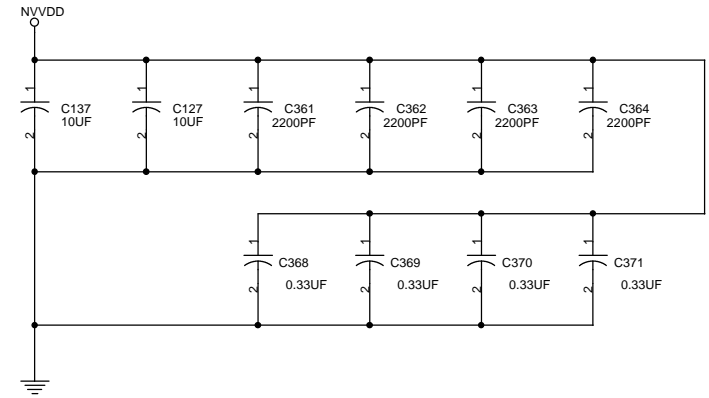
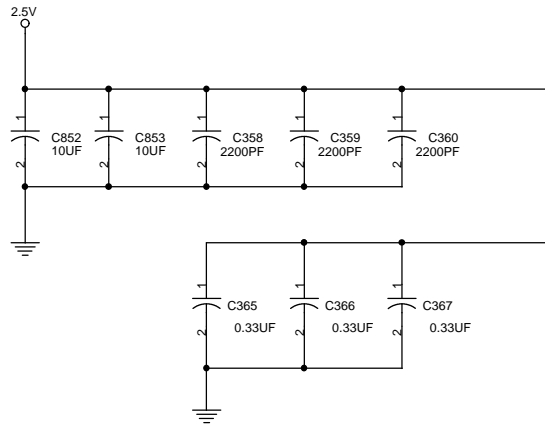
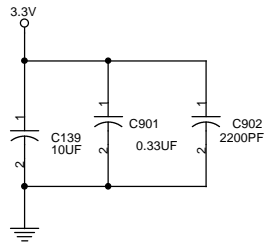

TO-263 2-pin package
NIKO-SEM L1085S3

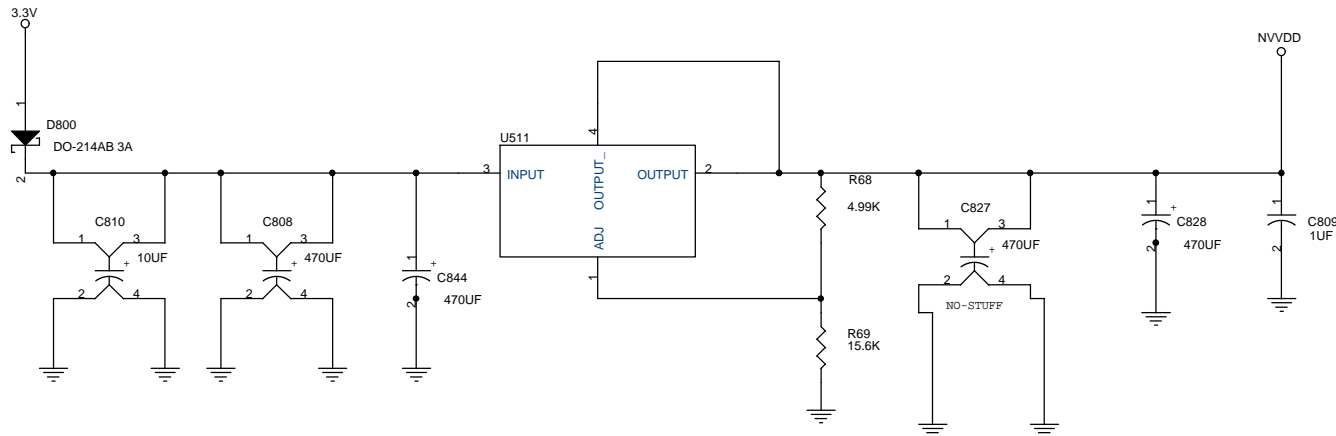

1y. NVXX DECOUPLING

 NVIDIA		NVIDIA Corporation 3535 Monroe St Santa Clara, CA 95051, USA		
		Size B	CAGE Code	DWG NO
Monday, March 11, 2002		Scale	Sheet 4 of 12	

(7,11) TVED[11:0] >>
 (7,11) VIPD[7:0] >>
 (12) DFPD[11:0] >>



1z. NVXX HOST STRAPS

 NVIDIA	NVIDIA Corporation 3535 Monroe St Santa Clara, CA 95051, USA			
	Size B	CAGE Code	DWG NO	Rev
Monday, March 11, 2002	Scale	Sheet	5 of 12	

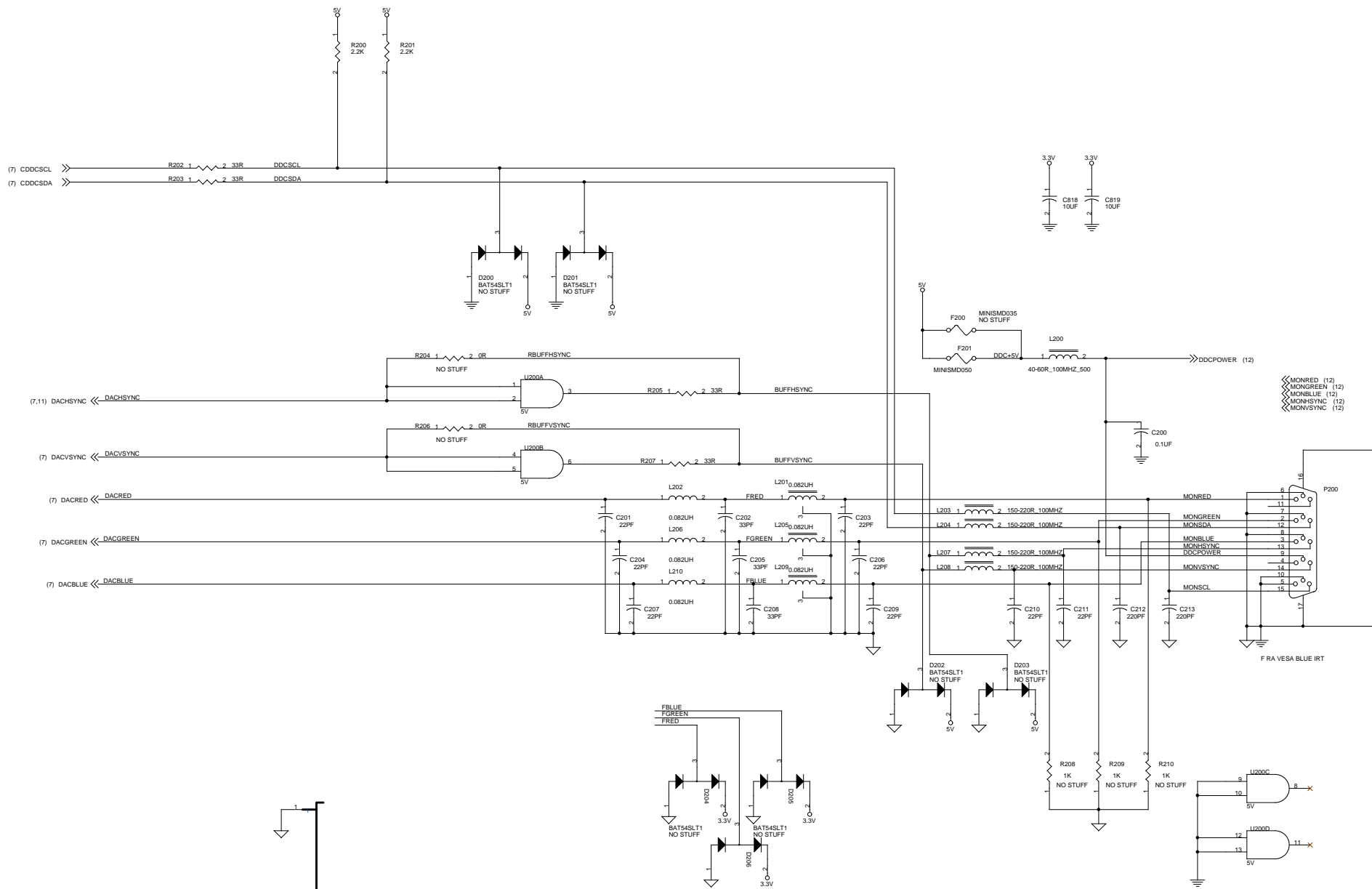

- MONRED (12)
- MONGREEN (12)
- MONBLUE (12)
- MONHSYNC (12)
- MONVSYNC (12)

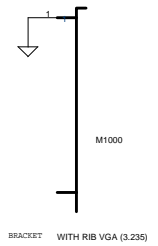

2a. DAC I/O

		NVIDIA Corporation 3535 Monroe St Santa Clara, CA 95051, USA		
		Size C	CAGE Code	DWG NO
Monday, March 11, 2002		Scale	Sheet	6 of 12

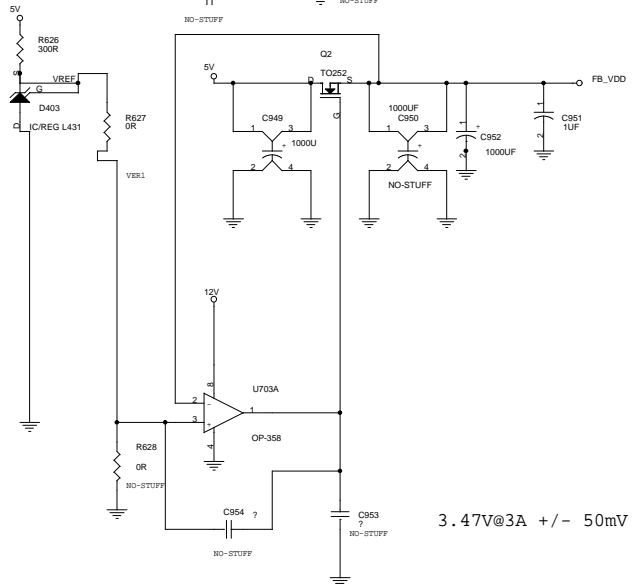
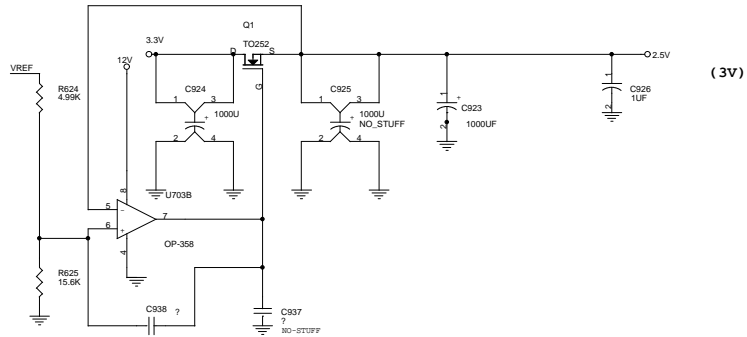
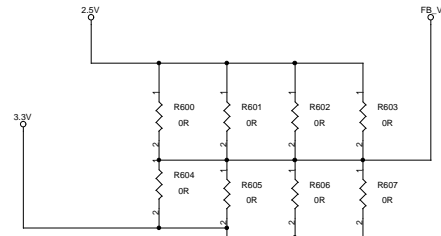
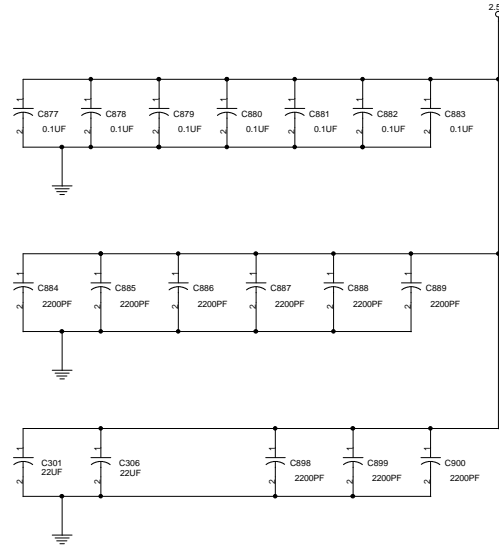
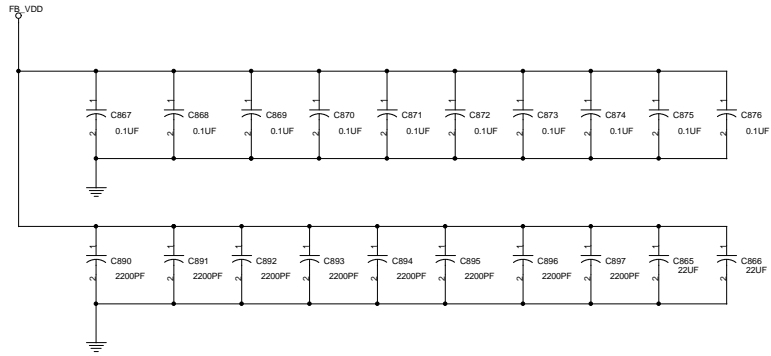

3b. FB DECOUPLING

		NVIDIA Corporation 3535 Monroe St Santa Clara, CA 95051, USA	
		Size	Rev
C	CAGE Code	DWG NO	
Monday, March 11, 2002	Scale	Sheet	9 of 12

- <<FBD[127:0] (8)
- <<CFBA0[13:0] (8)
- <<CFBAAS (8)
- <<CFBARAS (8)
- <<CFBACAS (8)
- <<CFBAWE (8)
- <<CFBACSO (8)
- <<CFBACSO_1 (8)
- <<CFBACSO_2 (8)
- <<CFBACSO_3 (8)
- <<CFBACSO_4 (8)
- <<CFBACSO_5 (8)
- <<CFBACSO_6 (8)
- <<CFBACSO_7 (8)
- <<CFBACSO_8 (8)
- <<CFBACSO_9 (8)
- <<CFBACSO_10 (8)
- <<CFBACSO_11 (8)
- <<CFBACSO_12 (8)
- <<CFBACSO_13 (8)
- <<CFBACSO_14 (8)
- <<CFBACSO_15 (8)
- <<CFBACSO_16 (8)
- <<CFBACSO_17 (8)
- <<CFBACSO_18 (8)
- <<CFBACSO_19 (8)
- <<CFBACSO_20 (8)
- <<CFBACSO_21 (8)
- <<CFBACSO_22 (8)
- <<CFBACSO_23 (8)
- <<CFBACSO_24 (8)
- <<CFBACSO_25 (8)
- <<CFBACSO_26 (8)
- <<CFBACSO_27 (8)
- <<CFBACSO_28 (8)
- <<CFBACSO_29 (8)
- <<CFBACSO_30 (8)
- <<CFBACSO_31 (8)
- <<CFBACSO_32 (8)
- <<CFBACSO_33 (8)
- <<CFBACSO_34 (8)
- <<CFBACSO_35 (8)
- <<CFBACSO_36 (8)
- <<CFBACSO_37 (8)
- <<CFBACSO_38 (8)
- <<CFBACSO_39 (8)
- <<CFBACSO_40 (8)
- <<CFBACSO_41 (8)
- <<CFBACSO_42 (8)
- <<CFBACSO_43 (8)
- <<CFBACSO_44 (8)
- <<CFBACSO_45 (8)
- <<CFBACSO_46 (8)
- <<CFBACSO_47 (8)
- <<CFBACSO_48 (8)
- <<CFBACSO_49 (8)
- <<CFBACSO_50 (8)
- <<CFBACSO_51 (8)
- <<CFBACSO_52 (8)
- <<CFBACSO_53 (8)
- <<CFBACSO_54 (8)
- <<CFBACSO_55 (8)
- <<CFBACSO_56 (8)
- <<CFBACSO_57 (8)
- <<CFBACSO_58 (8)
- <<CFBACSO_59 (8)
- <<CFBACSO_60 (8)
- <<CFBACSO_61 (8)
- <<CFBACSO_62 (8)
- <<CFBACSO_63 (8)
- <<CFBACSO_64 (8)
- <<CFBACSO_65 (8)
- <<CFBACSO_66 (8)
- <<CFBACSO_67 (8)
- <<CFBACSO_68 (8)
- <<CFBACSO_69 (8)
- <<CFBACSO_70 (8)
- <<CFBACSO_71 (8)
- <<CFBACSO_72 (8)
- <<CFBACSO_73 (8)
- <<CFBACSO_74 (8)
- <<CFBACSO_75 (8)
- <<CFBACSO_76 (8)
- <<CFBACSO_77 (8)
- <<CFBACSO_78 (8)
- <<CFBACSO_79 (8)
- <<CFBACSO_80 (8)
- <<CFBACSO_81 (8)
- <<CFBACSO_82 (8)
- <<CFBACSO_83 (8)
- <<CFBACSO_84 (8)
- <<CFBACSO_85 (8)
- <<CFBACSO_86 (8)
- <<CFBACSO_87 (8)
- <<CFBACSO_88 (8)
- <<CFBACSO_89 (8)
- <<CFBACSO_90 (8)
- <<CFBACSO_91 (8)
- <<CFBACSO_92 (8)
- <<CFBACSO_93 (8)
- <<CFBACSO_94 (8)
- <<CFBACSO_95 (8)
- <<CFBACSO_96 (8)
- <<CFBACSO_97 (8)
- <<CFBACSO_98 (8)
- <<CFBACSO_99 (8)
- <<CFBACSO_100 (8)

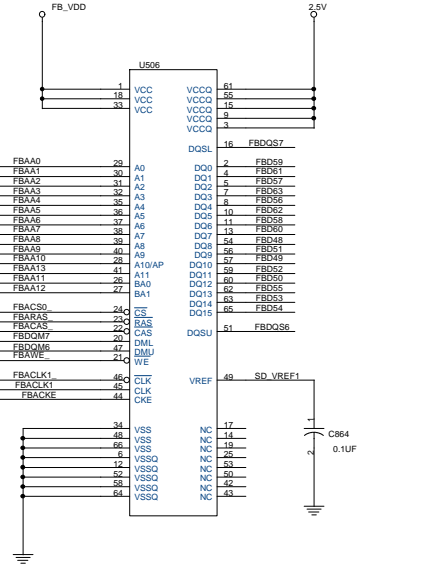
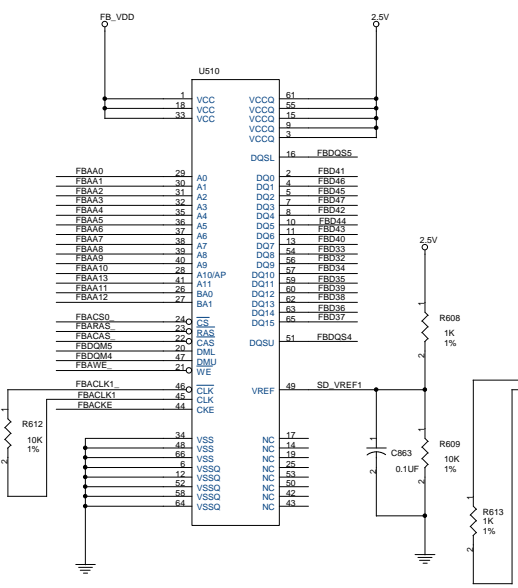
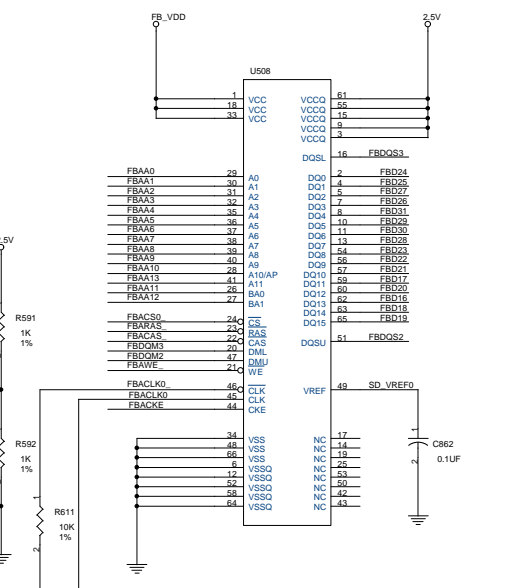
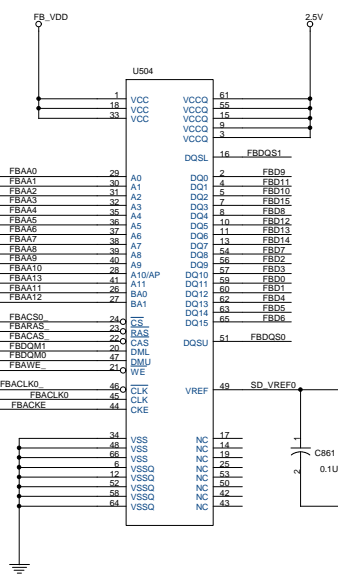
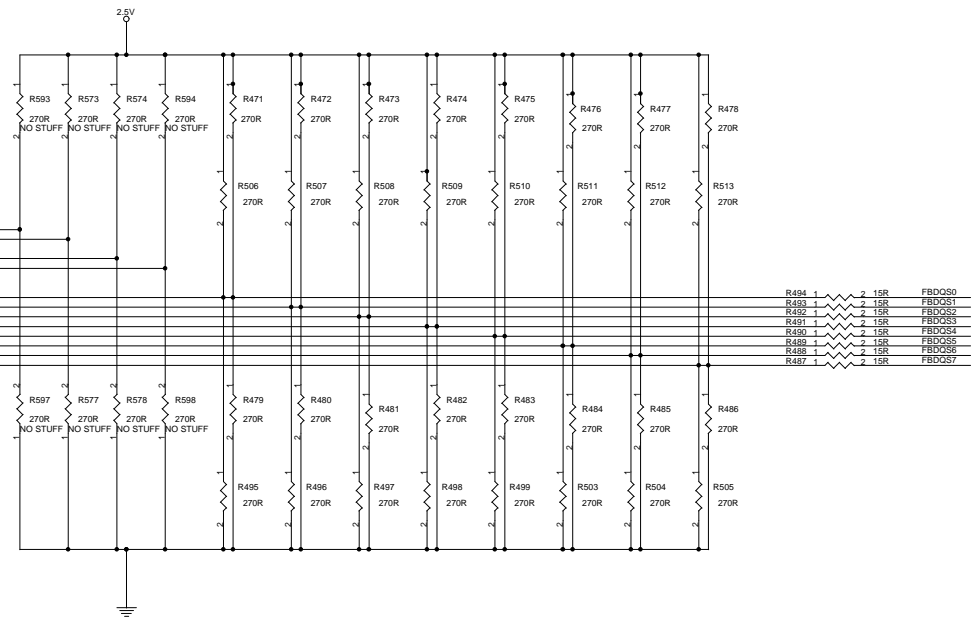
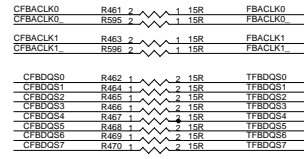
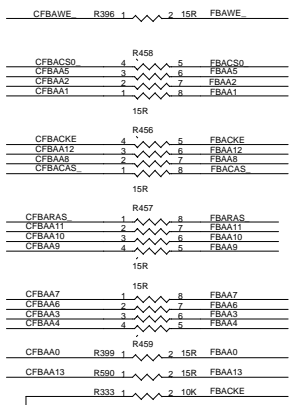

3c1. FBA 4MX16 DDR SDRAM

NVIDIA Corporation
3535 Monroe St
Santa Clara, CA 95051, USA

Size C	CAGE Code	DWG NO	Rev A
Scale		Sheet	10 of 12

Monday, March 11, 2002

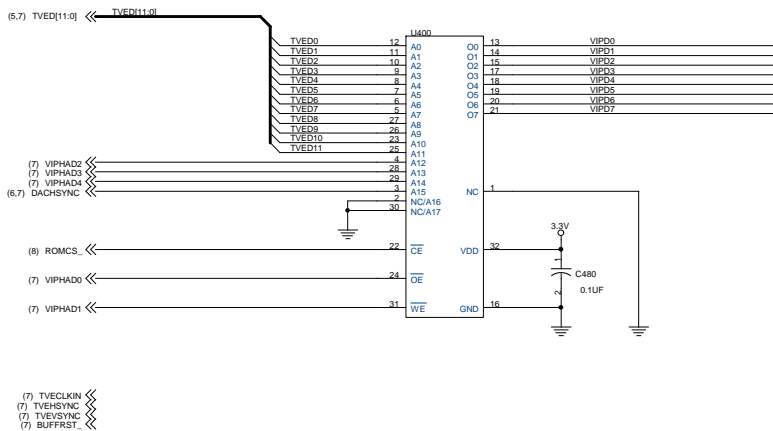
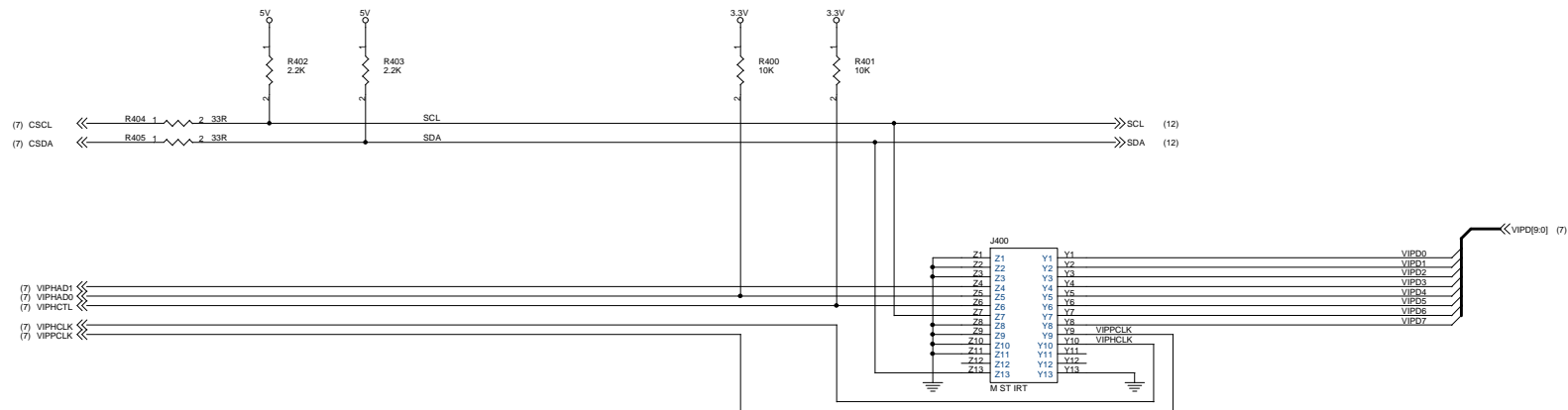

4a. ROM VIP & VIDEO IF

		NVIDIA Corporation 3535 Monroe St Santa Clara, CA 95051, USA	
		Scale	
Size C	CAGE Code	DWG NO	Rev
Monday, March 11, 2002		Sheet	11 of 12

<< TVED[1:0] (5,7,11)
 >> HMONS_ (8,11)
 << DFPCLK
 << DFPD[1:0] (5)
 << DFPVSYNC

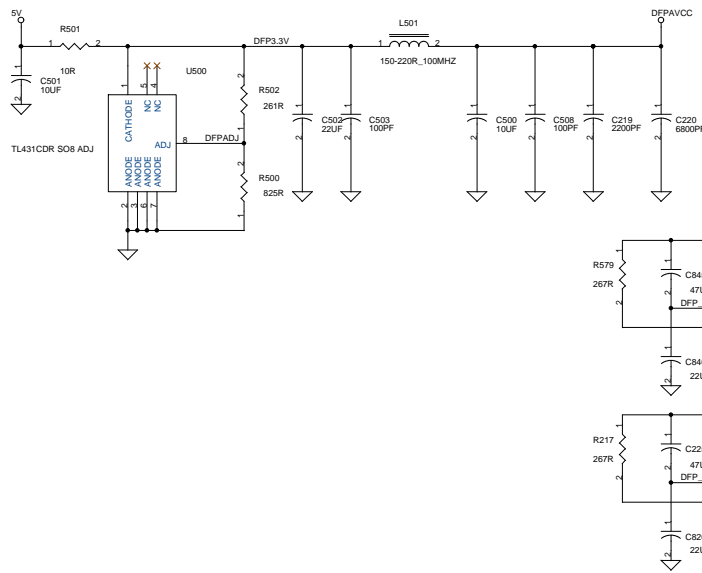
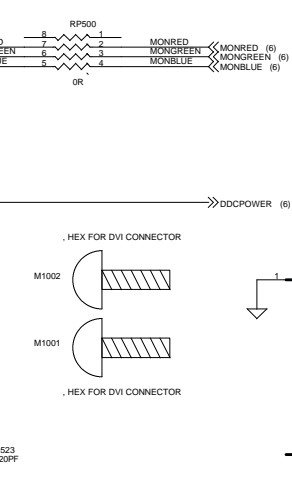
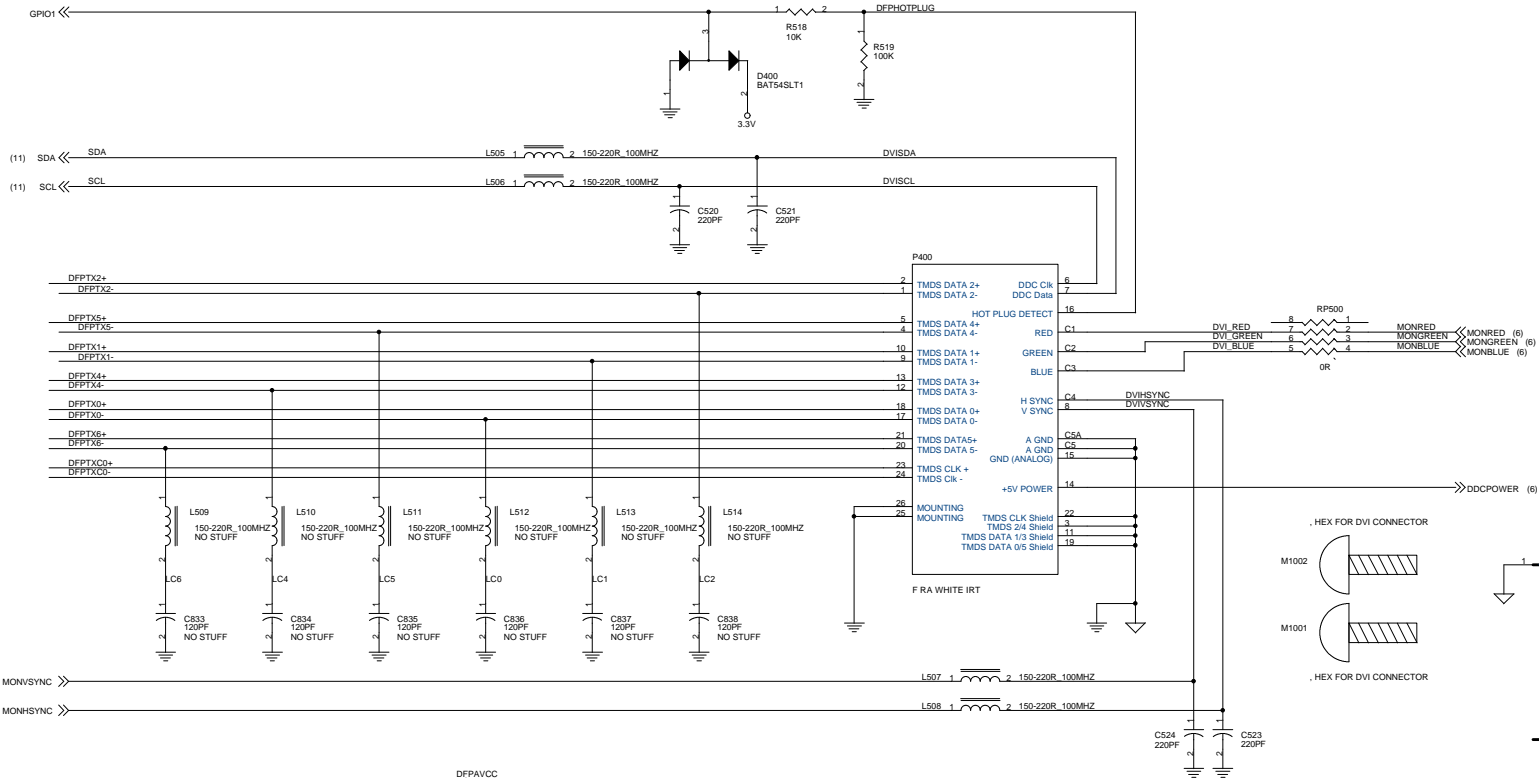

GPU Pin	GPU Label	GPU Pin	GPU Label	GPU Pin	GPU Label	GPU Pin	GPU Label
TP3	GPIO0	D9	GPIO0	IC238DA	A36	IC238DA	
GPIO0	GPIO0			IC238SCL	AK6	IC238SCL	
TP4	GPIO1	A8	GPIO1	TXD29	V1	DFPTX2-	
GPIO1	GPIO1			TXD2	V2	DFPTX2+	
TP1	GPIO2	A8	GPIO2	TXD44	V3	DFPTX4-	
GPIO2	GPIO2			TXD4	V4	DFPTX4+	
TP5	GPIO3	B9	GPIO3	TXD14	U3	DFPTX1-	
GPIO3	GPIO3			TXD1	U4	DFPTX1+	
TP6	GPIO4	D10	GPIO4	TXD38	W1	DFPTX3-	
GPIO4	GPIO4			TXD3	W2	DFPTX3+	
TP7	GPIO5	C10	GPIO5	TXD09	T3	DFPTX0-	
GPIO5	GPIO5			TXD0	T4	DFPTX0+	
				TXD5	AA1	DFPTX5-	
				TXD5F	AB1	DFPTX5+	
				TXD5			
				TXD8F	AC1	DFPTX6-	
				TXD6	AB2	DFPTX6+	
				TXD7F	AB3	DFPTX7-	
				TXD7	AB4	DFPTX7+	
				TXC0	T2	DFPTXC0+	
				TXC0F	T1	DFPTXC0-	
				TXC1	W3	DFPTX01-	
				TXC1F	W2	DFPTX01+	
				DFPD0	R3	DFPEN	DFPCLK
				DFPD1	P2		DFPCLK
				DFPD2	M3	DFPD0	
				DFPD3	L1	DFPD1	
				DFPD4	M4	DFPD2	
				DFPD5	M2	DFPD3	
				DFPD6	M1	DFPD4	
				DFPD7	N4	DFPD5	
				DFPD8	N3	DFPD6	
				DFPD9	N1	DFPD7	
				DFPD10	N2	DFPD8	
				DFPD11	P1	DFPD9	
				DFPVSYNC	R2	DFPD10	
				DFPHSYNC	R1	DFPD11	
					K1	DFPVSYNC	
					L3	DFPHSYNC	

5a. DVI-I I/O

NVIDIA Corporation
3535 Monroe St
Santa Clara, CA 95051, USA

Size C	CAGE Code	DWG NO	Rev A
Monday, March 11, 2002		Scale	Sheet 12 of 12