

FILE NO. SM-CTV-O-099

COLOR TELEVISION

SERVICE MANUAL

MODEL NO. 21C19/PF21C19

CHASSIS NO. EX-1A1

Please read this manual carefully before service

TABLE OF CONTENTS

SAFETY INSTRUCTIONS AND MAINTENANCE	1
X-RAY RADIATION PRECAUTION	1
SAFETY PRECAUTION	1
PRODUCT SAFETY NOTICE	2
SAFETY SYMBOL DESCRIPTION	2
MAINTENANCE	3
ADJUSTMENTS	4
SET-UP ADJUSTMENTS	4
CIRCUIT ADJUSTMENTS	7
STRUCTURE AND CHASSIS FUNCTION DESCRIPTION	12
STRUCTURE BLOCK DIAGRAM	12
BLOCK DIAGRAM FOR SUPPLY VOLTAGE SYSTEM	13
CHASSIS DESCRIPTION	14
SERVICE DATA	15
TECHNICAL DATA OF KEY ICS	15
WAVEFORMS OF KEY POINTS	33
SERVICE DATA OF KEY ICS	35
REPLACEMENT OF PARTS	39
APPENDIX	
1. CIRCUIT DIAGRAMS	
2. PRINTED CIRCUIT BOARD DIAGRAMS	
3. FINAL WIRING DIAGRAMS	
4. FINAL ASSEMBLY DIAGRAMS	

INSTRUCTIONS FOR SERVICE SAFETY AND MAINTENANCE

WARNING: BEFORE SERVICING THIS CHASSIS, READ THE "X-RAY RADIATION PRECAUTION", "SAFETY PRECAUTION" AND "PRODUCT SAFETY NOTICE" INSTRUCTION BELOW.

X-RAY RADIATION PRECAUTION

1. The EHT must be checked every time the TV is serviced to ensure that the CRT does not emit X-ray radiation as result of excessive EHT voltage. The maximum EHT voltage permissible in any operating circumstances must not exceed the rated value. When checking the EHT, use the High Voltage Check procedure in this manual using an accurate EHT voltmeter.
2. The only source of X-RAY radiation in this TV is the CRT. The TV minimizes X-RAY radiation, which ensures safety during normal operation. To prevent X-ray radiation, the replacement CRT must be identical to the original fitted as specified in the parts list.
3. Some components used in this TV have safety related characteristics preventing the CRT from emitting X-ray radiation. For continued safety, replacement component should be made after referring the PRODUCT SAFETY NOTICE below.
4. Service and adjustment of the TV may result in changes in the nominal EHT voltage of the CRT anode. So ensure that the maximum EHT voltage does not exceed the rated value after service and adjustment.

SAFETY PRECAUTION

WARNING: REFER SERVICING TO QUALIFIED SERVICE PERSONNEL ONLY.

1. The TV has a nominal working EHT voltage. Extreme caution should be exercised when working on the TV with the back removed.
 - 1.1 Do not attempt to service this TV if you are not conversant with the precautions and procedures for working on high voltage equipment.
 - 1.2 When handling or working on the CRT, always discharge the anode to the TV chassis before removing the anode cap in case of electric shock.
 - 1.3 The CRT, if broken, will violently expel glass fragments. Use shatterproof goggles and take extreme care while handling.
 - 1.4 Do not hold the CRT by the neck as this is a very dangerous practice.
2. It is essential that to maintain the safety of the customer all power cord forms be replaced exactly as supplied from factory.
3. Voltage exists between the hot and cold ground when the TV is in operation. Install a suitable isolating transformer of beyond rated overall power when servicing or connecting any test equipment for the sake of safety.
4. When replacing ICs, use specific tools or a static-proof electric iron with small power (below 35W).
5. Do not use a magnetized screwdriver when tightening or loosing the deflection yoke assembly to

SERVICE MANUAL

avoid electronic gun magnetized and decrement in convergence of the CRT.

6. When remounting the TV chassis, ensure that all guard devices, such as nonmetal control buttons, switch, insulating sleeve, shielding cover, isolating resistors and capacitors, are installed on the original place.
7. Replace blown fuses within the TV with the fuse specified in the parts list.
8. When replacing wires or components to terminals or tags, wind the leads around the terminal before soldering. When replacing safety components identified by the international hazard symbols on the circuit diagram and parts list, it must be the company-approved type and must be mounted as the original.
9. Keep wires away from high temperature components.

PRODUCT SAFETY NOTICE

CAUTION: FOR YOUR PROTECTION, THE FOLLOWING PRODUCT SAFETY NOTICE SHOULD BE READ CAREFULLY BEFORE OPERATING AND SERVICING THIS TV SET.

1. Many electrical and mechanical components in this chassis have special safety-related characteristics. These characteristics are often passed unnoticed by a visual inspection and the X-ray radiation protection afforded by them cannot necessarily be obtained by using replacements rated at higher voltages or wattage, etc. Components which have these special safety characteristics in this manual and its supplements are identified by the international hazard symbols on the circuit diagram and parts list. Before replacing any of these components read the parts list in this manual carefully. Substitute replacement components which do not have the same safety characteristics as specified in the parts list may create X-ray radiation.
2. Do not slap or beat the cabinet or CRT, since this may result in fire or explosion.
3. Never allow the TV sharing a plug or socket with other large-power equipment. Doing so may result in too large load, causing fire.
4. Do not allow anything to rest on or roll over the power cord. Protect the power cord from being walked on, modified, cut or pinched, particularly at plugs.
5. Do not place any objects, especially heavy objects and lightings, on top of the TV set. Do not install the TV near any heat sources such as radiators, heat registers, stove, or other apparatus that produce heat.
6. Service personnel should observe the SAFETY INSTRUCTIONS in this manual during use and servicing of this TV set. Otherwise, the resulted damage is not protected by the manufacturer.

SAFETY SYMBOL DESCRIPTION



The lightning symbol in the triangle tells you that the voltage inside this product may be strong enough to cause an electric shock. Extreme caution should be exercised when working on the TV with the back removed.

SERVICE MANUAL



This is an international hazard symbol, telling you that the components identified by the symbol have special safety-related characteristics.



FDA This symbol tells you that the critical components identified by the FDA marking have special safety-related characteristics.

UL This symbol tells you that the critical components identified by the UL marking have special safety-related characteristics.

C UL This symbol tells you that the critical components identified by the C-UL marking have been evaluated to the UL and C-UL standards and have special safety-related characteristics.

VDE This symbol tells you that the critical components identified by the VDE marking have special safety-related characteristics.

MAINTENANCE

1. Install the TV set on a stable and level surface. Do not place the set near or over a radiator or heat register, or where it is exposed to direct sunlight.
2. Do not install the TV set in a place exposed to rain, water, excessive dust, mechanical vibrations or impacts.
3. Allow enough space (at least 10cm) between the TV and wall or enclosures for proper ventilation.
4. Slots and openings in the cabinet should never be blocked by clothes or other objects.
5. Please power off the TV set and disconnect it from the wall immediately if any abnormal condition are met, such as bad smell, belching smoke, sparking, abnormal sound, no picture/sound/raster. Hold the plug firmly when disconnecting the power cord.
6. Unplug the TV set from the wall outlet before cleaning or polishing it. Use a dry soft cloth for cleaning the exterior of the TV set or CRT screen. Do not use liquid cleaners or aerosol cleaners.

ADJUSTMENTS

SET-UP ADJUSTMENTS

The following adjustments should be made when a complete realignment is required or a new picture tube is installed.

Perform the adjustments in the following order:

1. Color purity
2. Convergence
3. White balance

Notes:

The purity/convergence magnet assembly and rubber wedges need mechanical positioning.

For some picture tubes, purity/ convergence adjustments are not required.

1. **Color Purity Adjustment**

Preparation:

Before starting this adjustment, adjust the vertical sync, horizontal sync, vertical amplitude and focus.

- 1.1 Face the TV set north or south.
- 1.2 Connect the power plug into the wall outlet and turn on the main power switch of the TV set.
- 1.3 Operate the TV for at least 15 minutes.
- 1.4 Degauss the TV set using a specific degaussing coil.
- 1.5 Set the brightness and contrast to maximum.
- 1.6 Counter clockwise rotate the R/B low brightness potentiometers to the end and rotate the green low brightness potentiometer to center.
- 1.7 Receive green raster pattern signals.
- 1.8 Loosen the clamp screw holding the deflection yoke assembly and slide it forward or backward to display a vertical green zone on the screen. Rotate and spread the tabs of the purity magnet around the neck of the CRT until the green zone is located vertically at the center of the screen.
- 1.9 Slowly move the deflection yoke assembly forward or backward until a uniform green screen is obtained.
- 1.10 Tighten the clamp screw of the assembly temporarily. Check purity of the red raster and blue raster until purities of the three rasters meet the requirement.

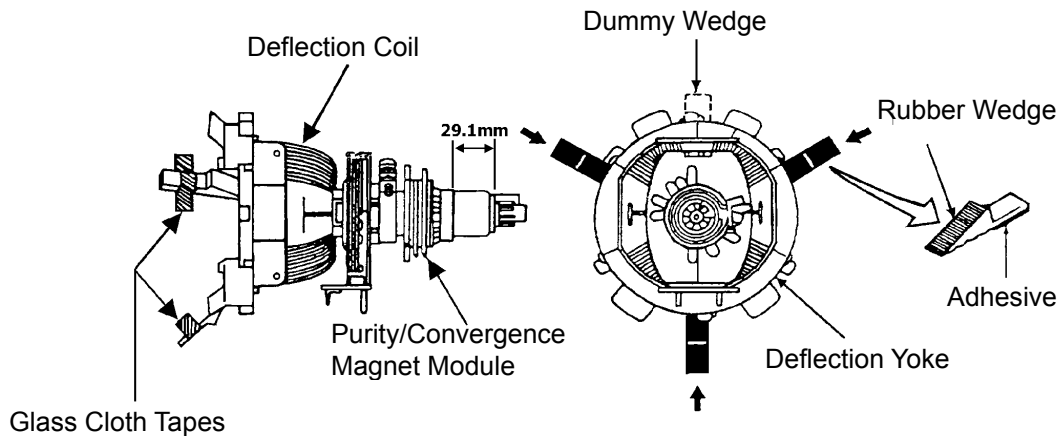

Fig. 1

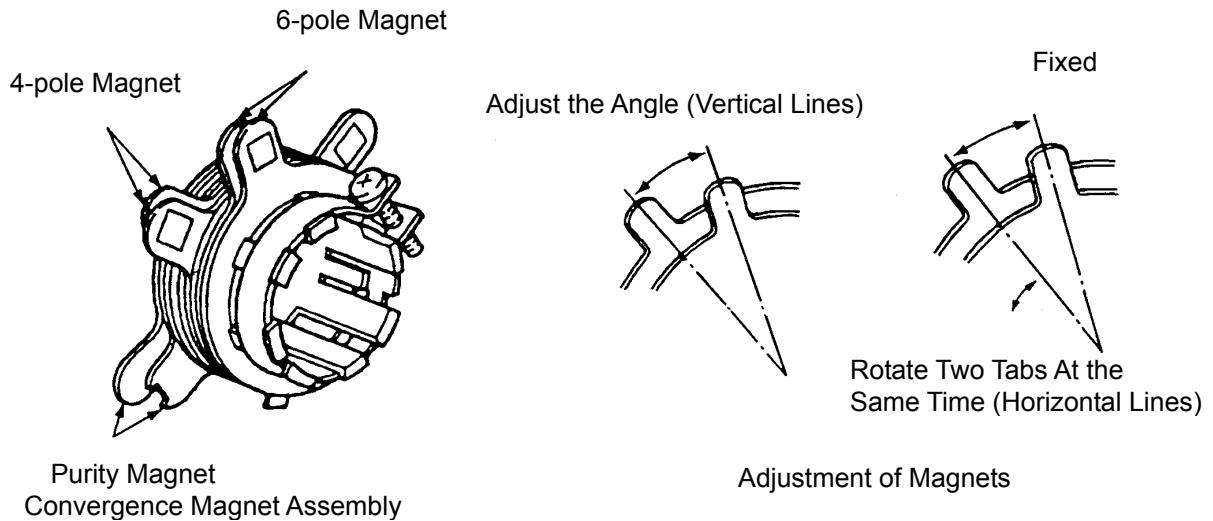

Fig. 2

2. Convergence Adjustment

Preparation:

Before attempting any convergence adjustment, the TV should be operated for at least 15 minutes.

2.1 Center convergence adjustment

- 2.1.1 Receive dot pattern.
- 2.1.2 Adjust the brightness/contrast controls to obtain a sharp picture.
- 2.1.3 Adjust two tabs of the 4-pole magnet to change the angle between them and red and blue vertical lines are superimposed each other on the center of the screen.
- 2.1.4 Turn both tabs at the same time keeping the angle constant to superimpose red and blue horizontal on the center of the screen.
- 2.1.5 Adjust two tabs of the 6-pole magnet to superimpose red/blue line and green line.
- 2.1.6 Remember red and blue movement. Repeat steps 2.1.3 ~ 2.1.5 until optimal convergence is

obtained.

2.2 Circumference convergence adjustment

- 2.2.1 Loosen the clamp screw holding the deflection yoke assembly and allow it tilting.
- 2.2.2 Temporarily put the first wedge between the picture tube and deflection yoke assembly. Move front of the deflection yoke up or down to obtain better convergence in circumference. Push the mounted wedge in to fix the yoke temporarily.
- 2.2.3 Put the second wedge into bottom.
- 2.2.4 Move front of the deflection yoke to the left or right to obtain better convergence in circumference.
- 2.2.5 Fix the deflection yoke position and put the third wedge in either upper space. Fasten the deflection yoke assembly on the picture tube.
- 2.2.6 Detach the temporarily mounted wedge and put it in either upper space. Fasten the deflection yoke assembly on the picture tube.
- 2.2.7 After fastening the three wedges, recheck overall convergence and ensure to get optimal convergence. Tighten the lamp screw holding the deflection yoke assembly.

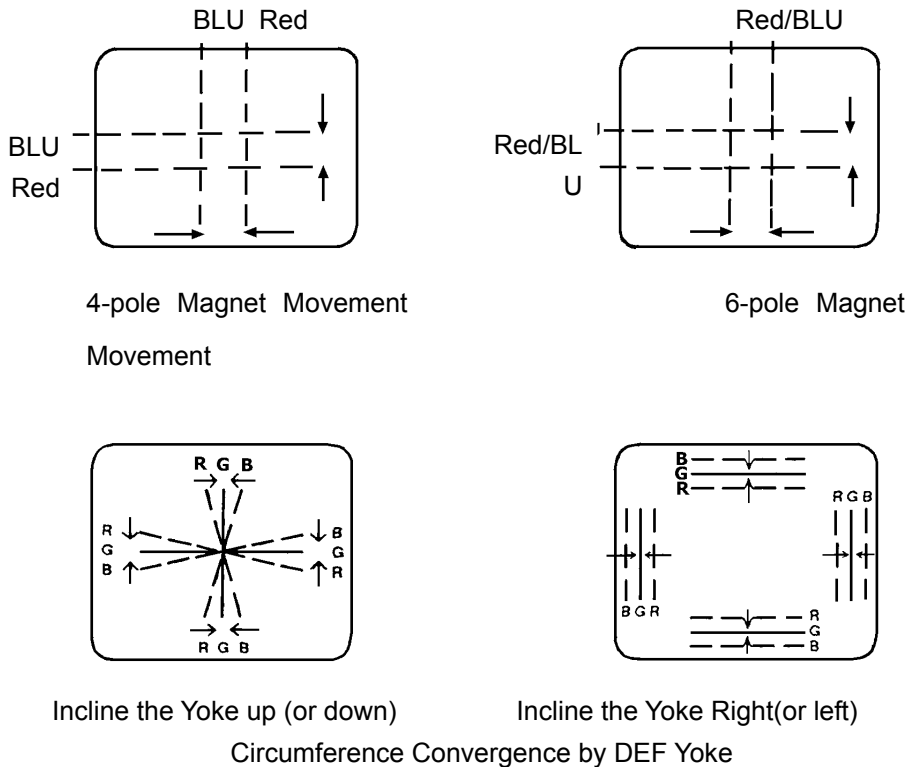

Fig. 3

3. White Balance Adjustment

Generally, white balance adjustment is made with professional equipment. It's not practical to get good white balance only through manual adjustment. For TVs with I²C bus control, change the bus data to adjust white balance.

CIRCUIT ADJUSTMENTS

Preparation:

Circuit adjustments should be made only after completion of set-up adjustments.

Circuit adjustments can be performed using the adjustable components inside the TV set. For TVs with I²C bus control, first change the bus data.

1. Degaussing

A degaussing coil is built inside the TV set. Each time the TV is powered on, the degaussing coil will automatically degauss the TV. If the TV is magnetized by external strong magnetic field, causing color spot on the screen, use a specific degausser to demagnetize the TV in the following ways. Otherwise, color distortion will be shown on the screen.

- 1.1 Power on the TV set and operate it for at least 15 minutes.
- 1.2 Receive red full-field pattern.
- 1.3 Power on the specific degausser and face it to the TV screen.
- 1.4 Turn on the degausser. Slowly move it around the screen and slowly take it away from the TV.
- 1.5 Repeat the above steps until the TV is degaussed completely.

2. Supply Voltage Adjustment

Caution: +B voltage has close relation to high voltage. To prevent X-ray radiation, set +B voltage to the rated voltage.

- 2.1 Make sure that the supply voltage is within the range of the rated value.
- 2.2 Connect a digital voltmeter to the +B voltage output terminal of the TV set. Power on the TV and set the brightness and sub-brightness to minimum.
- 2.3 Regulate voltage adjustment components on the power PCB to make the voltmeter read $115 \pm 1V$.

3. High Voltage Inspection

Caution: No high voltage adjustment components inside the chassis. Please perform high voltage inspection in the following ways.

- 3.1 Connect a precise static high voltmeter to the second anode (inside the high voltage cap) of the picture tube.
- 3.2 Plug in the supply socket (150-250V, AC, 50Hz) and turn on the TV. Set the brightness and contrast to minimum ($0 \mu A$).
- 3.3 The high voltage reading should be less than the EHT limitation.
- 3.4 Change the brightness from minimum to maximum, and ensure high voltage not beyond the limitation in any case.

Nominal EHT voltage: $27.5 \pm 1KV$ Limited EHT voltage: 30KV

4. Focus Adjustment

Caution: Dangerously high voltages are present inside the TV. Extreme caution should be exercised when working on the TV with the back removed.

- 4.1 After removing the back cover, look for the FBT on the main PCB. There should be a FCB on the FBT.
- 4.2 Power on the TV and preheat it for 15 min.

SERVICE MANUAL

4.3 Receive a normal TV signal. Rotate knob of the FCB until you get a sharp picture.

5. Safety Inspection

5.1 Inspection for insulation and voltage-resistant

Perform safety test for all naked metal of the TV. Supply high voltage of 3000V AC, 50Hz (limit current of 10mA) between all naked metal and cold ground. Test every point for 3 min. and ensure no arcing and sparking.

5.2 Requirements for insulation resistance

Measure resistance between naked metal of the TV and feed end of the power cord to be infinity with a DC-500 high resistance meter and insulation resistance between the naked metal and degaussing coil to be over 20M .

6. DESIGN/SERVICE mode

6.1 To enter the USER SERVICE mode

Caution: The user service mode adjustment can be changed only when service personnel adjust the whole set data during servicing. As the control data have dramatic effects on functions and performance of the TV, service personnel should not tell user how to enter the SERVICE mode to avoid improper data settings.

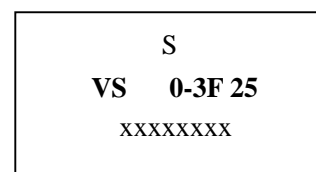

6.1.1 Set the volume to 0. Then press and hold the MUTE button on the remote control, and press the MENU button on the TV to enter the SERVICE mode. (In this case, the S mode cannot be stored in the EEPROM. To exit from the S mode, turn off the TV set.)

6.1.2 After entering the S mode, Red " S "is displayed on the upper center of the screen and MENU1 is default. Use the POS+/- buttons to highlight an adjustment and the VOL+/- buttons to adjust it. The adjusted data are immediately output and stored in the EEPROM

6.2 Bus data in the S mode

Item	Bus Data	Description	Remarks
5PAR/6PAR	1F	Parallelogram correction (for large-screen only)	
5BOW/6BOW	1F	Curve correction (for large-screen only)	
5HSH/6HSH	Set to the optimal mode	Horizontal center in the TV mode for 50Hz/60Hz For 50Hz, " 5HSH " is displayed ; for 60Hz, " 6HSH " is displayed.	*
5HSR/6HSR	Set to the optimal mode	Horizontal center in the RGB mode for 50Hz/60Hz For 50Hz, " 5HSR " is displayed ; for 60Hz, " 6HSR " is displayed.	*
5EWP/6EWP	1F	East-West parabola correction (for large-screen only)	
5EWW/6EWW	1F	East-West correction (for large-screen only)	
5UCR/6UCR	1F	Upper corner parabola correction (for large-screen only)	
5LCR/6LCR	1F	Lower corner parabola correction (for large-screen only)	
5EWT/6EWT	1F	Trapezoidal correction (for large-screen only)	

(continued)

SERVICE MANUAL

5VSL/6VSL	1F	Vertical slope (for large-screen only)	*
5VAM/6VAM	1F	Vertical amplitude; For 50Hz, " 5VAM " is displayed ; for 60Hz, " 6VAM " is displayed.	*
5SCL/6SCL	Set to the optimal mode	S correction	*
5VSH/6VSH	Set to the optimal mode	Vertical center	*
5VOF/6VOF	Set to the optimal mode	OSD vertical center	*
VX	19	Vertical zoom (for large-screen only)	
RED	20	Red gun cutoff voltage	*
GRN	20	Green gun cutoff voltage	*
WPR	1F	Red gun drive voltage	*
WPG	1F	Green gun drive voltage	*
WPB	1F	Blue gun drive voltage	*
YDFP	07	PAL brightness delay time	
YDFN	07	NTSC brightness delay time	
YDFS	0F	SECAM brightness delay time	
YDAV	0F	AV brightness delay time	
TOP	18	UOC AGC	*
VOL	21	UOC audio output amplitude	*
IFFS	03 (02)	PIF (02-38.9MHz, 03-38MHz)	
HDOL	00	Cathode drive level	
AGC	03	IF ACG speed	
VG2B	3A	VG2 brightness	*
SBRI	1F	Sub brightness	
MBRI	39	Max. brightness	
SCON	20	Sub contrast	
MCON	3F	Max. contrast	
SCOL	32	Sub color	
OP1	BF	Option set byte 1	
OP2	01	Option set byte 2	
OP3	09	Option set byte 3	
OP4	F6	Option set byte 4	
OP5	76	Option set byte 5	
OP6	3D	Option set byte 6	
INIT		EEPROM initialization	
VG2		Adjusting screen voltage with VG2	
VSD		Vertical output off	
USER_LOGO		User logo write-in (valid when OP-USER-LOGO is 1)	
STS0/1/2		System status byte	

SERVICE MANUAL

Notes:

The data marked with “ * ” have been adjusted in the MANUFACTURE mode. Take care when in service and adjustment.

To write in logo, use the / buttons to highlight an adjustment and the / buttons to adjust.

The data sheet may differ dependent on different models.

The data sheet may differ dependent on different CRTs for the same model.

6.3 Option set

With remote control system software TDA935X, all options can be set in the SERVICE mode and stored in EEPROM. Data related to picture, sound and geometric adjustment are also stored in EEPROM.

	Bit	Item	Description	Default
OP1	0	OP_HOTEL	HOTEL mode	1
	1	OP_236	100/236 programs preset	0
	2	OP_NTSC	NTSC option set	1
	3	OP_AV2	Two set of AV terminals: 1-With AV2; 0-Without AV2	1
	4	OP_SVHS	S-Video terminal	1
	5	OP_DVD	DVD	1
	6	OP_RGB	RGB: 1- RGB 0-No	0
	7	OP_OSO	Switch off in vertical overscan	0
OP2	0	OP_AVL	AVL	1
	1	OP_AUTO_SOUND	Auto sound system test	1
	2	OP_NOT_1	National Option Set (OP_NOT_3/2/1) : 1XX-Arabic , 011-Farsi , 010-Russian , 001-Ukrainian , 000-Paneuro	0
	3	OP_NOT_2		0
	4	OP_NOT_3		0
	5	OP_USER_LOGO	User logo (prior to CHANGHONG logo)	0
	6	OP_ON_BACK	Auto test background options when power-on: 0-black; 1-blue	0
	7	OP_FSL	Slicing level for vertical sync	0
OP3	0	OP_ENGLISH	English	1
	1	OP_FARSI	Farsi	1
	2	OP_ARABIC	Arabic	1
	3	OP_RUSSIAN	Russian	1
	4	OP_FRENCH	French	1

(continued)

SERVICE MANUAL

	5	OP_GERMAN	German	1
	6	OP_INDIA	Indonesian	1
	7	OP_MALAYSIA	Malay	1
OP4	0	OP_FMWS	Window selection of sound pll: small/large window	0
	1	OP_DIRECT_SWIT CH_ON	Memory power-on (If turned off by the remote control, then the TV is turned on by the remote control; if turned off by the MAIN POWER SWITCH, then turned on by the MAIN POWER SWITCH.)	1
	2	OP_HCO	EHT tracking mode	0
	3	OP_CHH_LOGO	User logo display : 1-Displayed without signal reception ; 0-No	1
	4	OP_SOUND_DK	Sound system-DK option set	1
	5	OP_SOUND_BG	Sound system-BG option set	0
	6	OP_SOUND_I	Sound system-I option set	1
	7	OP_SOUND_M	Sound system-M option set	1
OP5	0	OP_TUNER	Tuner : 1-Philips Tuner 0-Panasonic Tuner	0
	1	OP_AUTO_LANG0	Auto language option set: English - Farsi - Arabic - Russian - French - German - Indonesian - Malay	1
	2	OP_AUTO_LANG1		0
	3	OP_AUTO_LANG2		0
	4	OP_FORF	Field frequency options (OP_FORF/FORF): 00-Auto60Hz, 01-KeepLast, 10-Force60Hz, 11-Auto50Hz	0
	5	OP_FORF		0
	6	OP_AVON	If AV off, then AV on	1
	7	OP_ONPOSITION	With HOTEL mode preset, on position is fixed to POS1.	0
OP6	0	OP_AUTOTEST	Auto test when power-on	0
	1	OP_PSNS	Sensitivity	0
	2	OP_BSCREEN	Black screen when changing channels: 1-yes ; 0-No	1
	3	OP_SECAM	1: SECAM option	1
	4	OP_DFL	Disable flash protection	0
	5	OP_SIF	External input for sound IF circuit	1
	6	OP_EXT_SIF0	Sound system options for external circuit: 00-DK, 01-BG, 10-I, 11-M (Valid when OP_SIF = 1)	1
	7	OP_EXT_SIF1		0

STRUCTURE AND CHASSIS FUNCTION DESCRIPTION

1. STRUCTURE BLOCK DIAGRAM

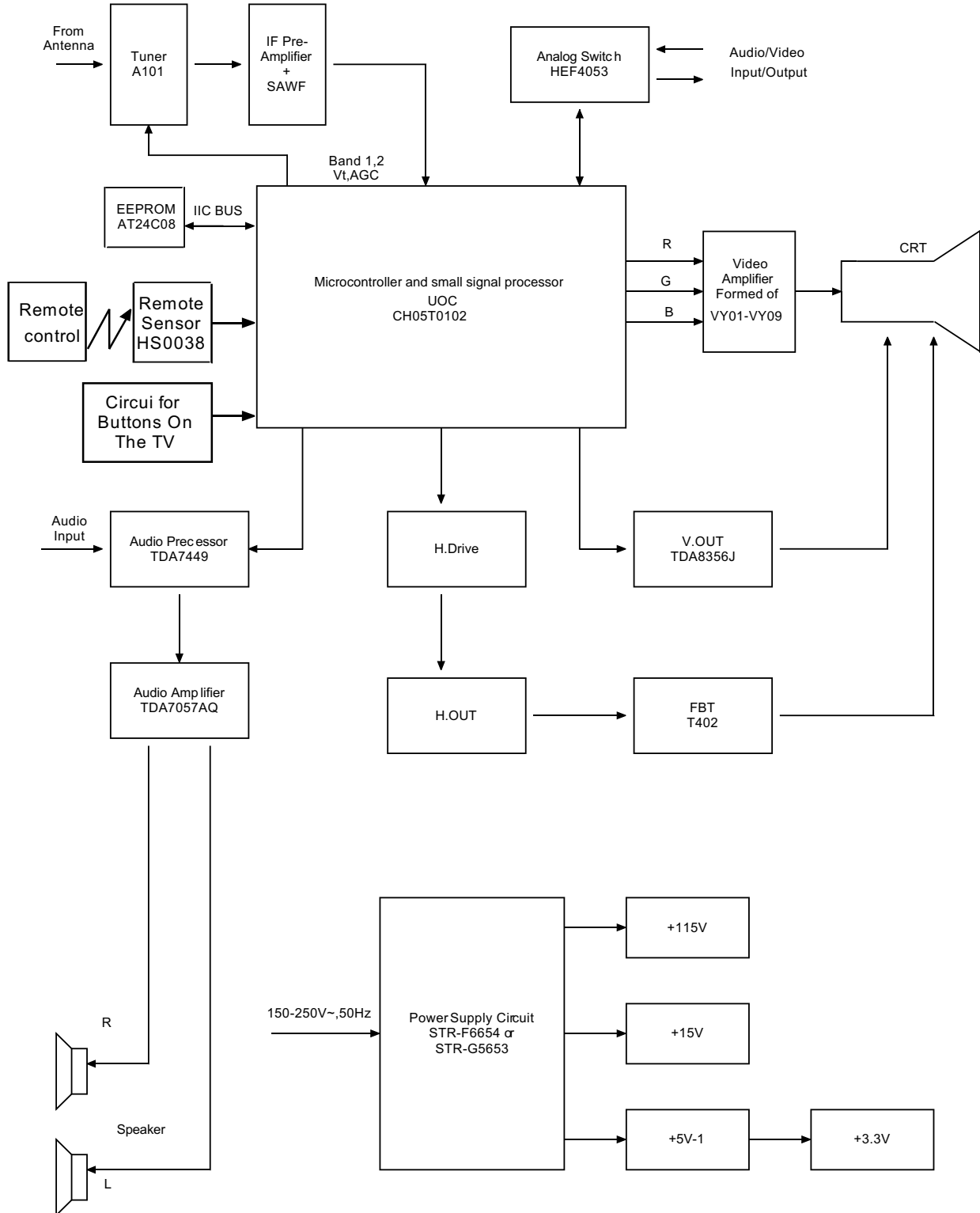

Fig.4 Structure Block Diagram for EX-1A1 Chassis Series

2. BLOCK DIAGRAM FOR SUPPLY VOLTAGE SYSTEM

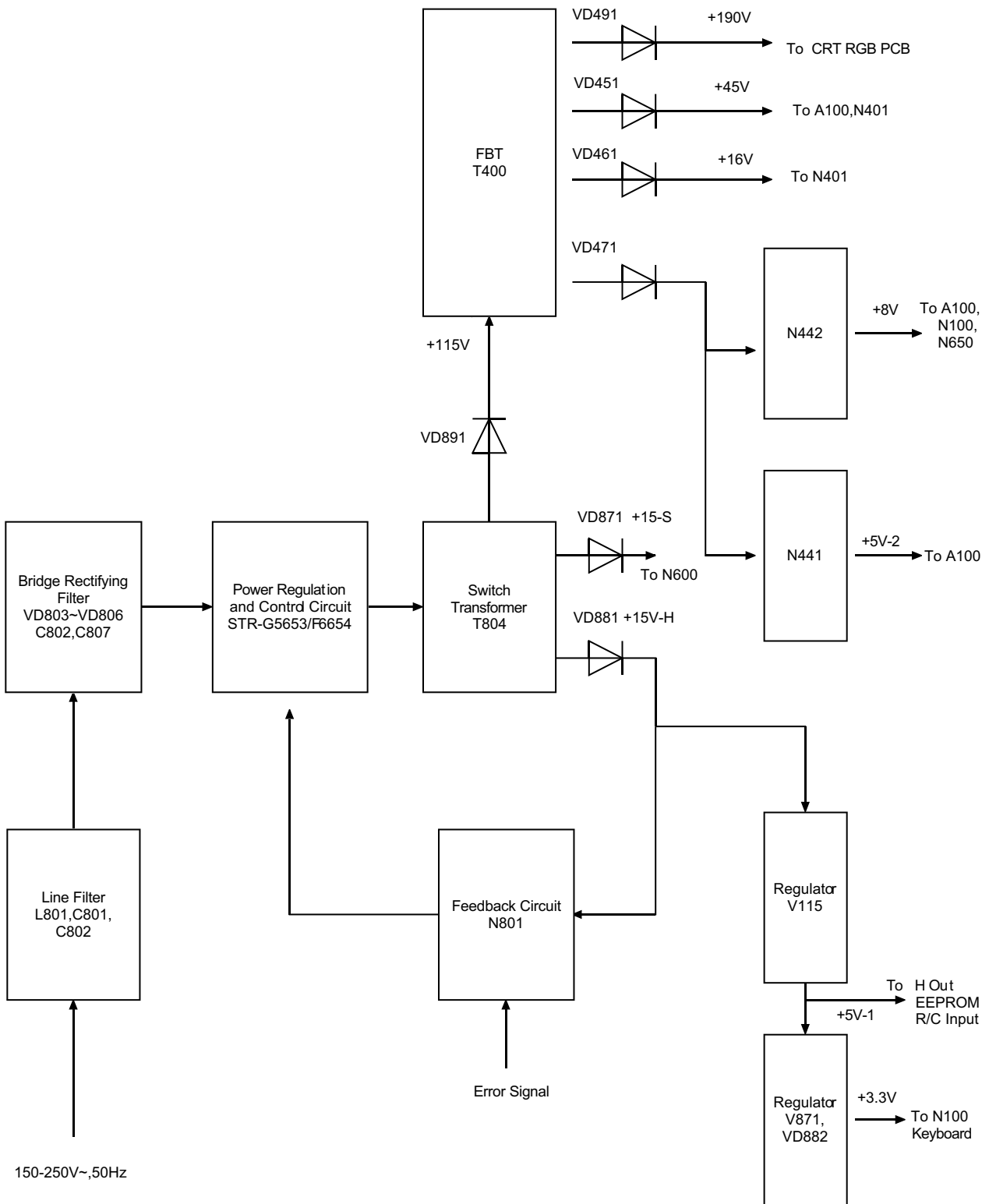

Fig.5 Block Diagram for EX-1A1 Supply Voltage System

3. CHASSIS DESCRIPTION

1). General Description

EX-1A1 chassis series are applied in 21C19/PF21C19 respectively which uses mainly Philips' advanced UOC-ultimate chip TDA935X/6X/8X and I²C-bus controlled IC. With combination of microcontroller and small signal processor, the TDA935X/6X/8X series feature high-integration, high-performance-to-price ratio and high-reliability and advanced functions with fewer external components, which provide much convenience for manufacturing and technical service.

2). The EX-1A1chassis series mainly use the following ICs and assemblies.

Table 1 Key ICs and Assemblies

Serial No.	Position	Type	Function Description
1	N100	TDA935X/6X/8X (CH05T0102)	Microcontroller and small signal processor(UOC)
2	N200	AT24C08	EEPROM
3	N650	TDA7449	Audio processor
4	N401	TDA8356/N6	Vertical scan output stage circuit
5	N600	TDA7057AQ	Sound power amplifier
6	N861	STR-G5653/F6654	Power supply circuit
7	N402	HEF4053	Analog switch
8	A100	TDQ-5B6M	Tuner

SERVICE DATA

1. KEY ICS TECHNICAL DATA

1.1 *Microcontroller and small signal processor TDA935X/6X/8X*

The super chips TDA935X/6X/8X are good in pins compatibility. Differences among them are shown as follows.

TDA9351 (48K)	PAL/NTSC/SECAM+1 PAGE TELETTEST
TDA9350 (48K)	PAL/NTSC+1 PAGE TELETTEST
TDA9361 (64K)	PAL/NTSC/SECAM+10 PAGE TELETTEST
TDA9360 (64K)	PAL/NTSC+10 PAGE TELETTEST
TDA9380 (32K)	PAL/NTSC
TDA9387 (32K)	NTSC

TDA935X/6X/8X PS/N2 series TV signal processor-Teletext decoder with embedded -Controller

1) General Description

The various versions of the TDA935X/6X/8X PS/N2 series combine the functions of a TV signal processor together with a -Controller and US Closed Caption decoder. Most versions have a Teletext decoder on board. The Teletext decoder has an internal RAM memory for 1 or 10 page text. The ICs are intended to be used in economy television receivers with 90 , and 110 , picture tubes. The ICs have supply voltages of 8 V and 3.3 V and they are mounted in S-DIP envelope with 64 pins.

The features are given in the following feature list. The differences between the various ICs are given in the table on page 4.

2) Features

TV-signal processor

Multi-standard vision IF circuit with alignment-free PLL demodulator

Internal (switchable) time-constant for the IF-AGC circuit

A choice can be made between versions with mono intercarrier sound FM demodulator and versions with QSS IF amplifier.

The mono intercarrier sound versions have a selective FM-PLL demodulator which can be switched to the different FM sound frequencies (4.5/5.5/6.0/6.5 MHz).

The quality of this system is such that the external band-pass filters can be omitted.

Source selection between 'internal' CVBS and external CVBS or Y/C signals

Integrated chrominance trap circuit

Integrated luminance delay line with adjustable delay time

Picture improvement features with peaking (with variable centre frequency and positive/negative overshoot ratio) and black stretching

Integrated chroma band-pass filter with switchable centre frequency

Only one reference (12 MHz) crystal required for the

-Controller, Teletext- and the colour decoder

PAL/NTSC or multi-standard colour decoder with automatic search system
Internal base-band delay line
RGB control circuit with 'Continuous Cathode Calibration', white point and black level offset adjustment so that the colour temperature of the dark and the light parts of the screen can be chosen independently.
Linear RGB or YUV input with fast blanking for external RGB/YUV sources. The Text/OSD signals are internally supplied from the -Controller/Teletext decoder
Contrast reduction possibility during mixed-mode of OSD and Text signals
Horizontal synchronization with two control loops and alignment-free horizontal oscillator
Vertical count-down circuit
Vertical driver optimized for DC-coupled vertical output stages
Horizontal and vertical geometry processing
Horizontal and vertical zoom function for 16 : 9 applications
Horizontal parallelogram and bow correction for large screen picture tubes
Low-power start-up of the horizontal drive circuit

TV signal processor-Teletext decoder with embedded -Controller TDA935X/6X/8X PS/N2 series -Controller

80C51 -controller core standard instruction set and timing
1 s machine cycle
16 - 128Kx8-bit late programmed ROM
3 - 12Kx8-bit DATA RAM (shared between Display, Acquisition and Auxiliary Ram)
Interrupt controller for individual enable/disable with two level priority
Two 16-bit Timer/Counter registers
One 16 bit Timer with 8-bit Pre-scaler
WatchDog timer
Auxiliary RAM page pointer
16-bit Data pointer
Stand-by, Idle and Power Down (PD) mode
14 bits PWM for Voltage Synthesis Tuning
8-bit A/D converter
4 pins which can be programmed as general I/O pin, ADC input or PWM (6-bit) output

Data Capture

Text memory for 0, 1 or 10 pages
In the 10 page versions inventory of transmitted Teletext pages stored in the Transmitted Page Table (TPT) and Subtitle Page Table (SPT)
Data Capture for US Closed Caption
Data Capture for 525/625 line WST, VPS (PDC system A) and Wide Screen Signalling (WSS) bit decoding
Automatic selection between 525 WST/625 WST
Automatic selection between 625 WST/VPS on line 16 of VBI
Real-time capture and decoding for WST Teletext in Hardware, to enable optimized -processor throughput
Automatic detection of FASTEXT transmission

3) Block Diagram

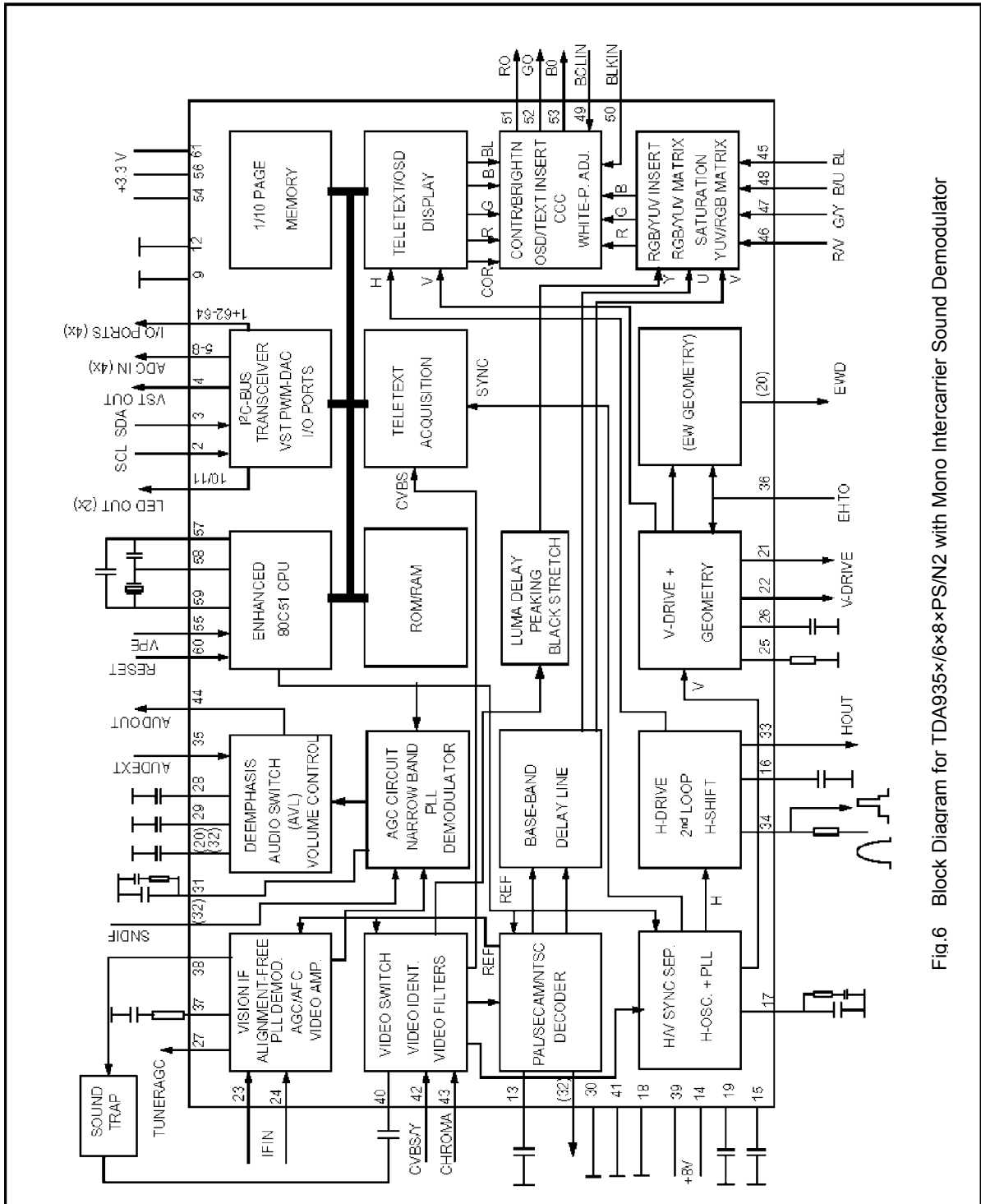

Fig.6 Block Diagram for TDA935x/6x8xPS/N2 with Mono Intercarrier Sound Demodulator

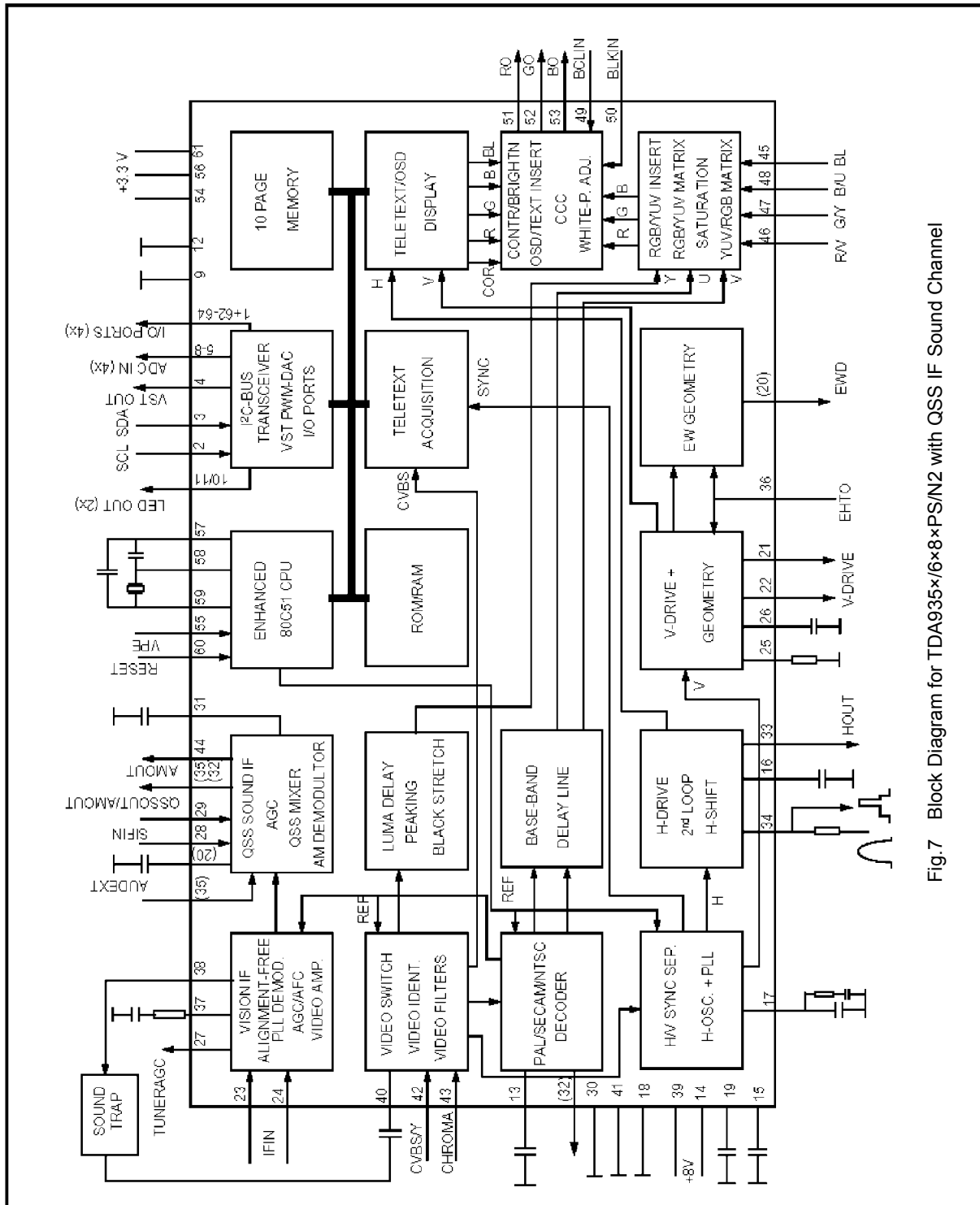

Fig.7 Block Diagram for TDA935x/6x8xPS/N2 with QSS IF Sound Channel

4) pinning

SYMBOL	PIN	DESCRIPTION
P1.3/T1	1	port 1.3 or Counter/Timer 1 input
P1.6/SCL	2	port 1.6 or I ² C-bus clock line
P1.7/SDA	3	port 1.7 or I ² C-bus data line
P2.0/TPWM	4	port 2.0 or Tuning PWM output
P3.0/ADCO/PWMO	5	port 3.0 or ADC0 input or PWM0 output
P3.1/ADC1/PWM1	6	port 3.1 or ADC1 input or PWM1 output
P3.2/ADC2/PWM2	7	port 3.2 or ADC2 input or PWM2 output
P3.3/ADC3/PWM3	8	port 3.3 or ADC3 input or PWM3 output
VSSC/P	9	digital ground for μ -Controller core and periphery
P0.5	10	port 0.5 (8mA current sinking capability for direct drive of LEDs)
P0.6	11	port 0.6 (8mA current sinking capability for direct drive of LEDs)
VSSA	12	analog ground of Teletext decoder and digital ground of TV-processor
SECPLL	13	SECAM PLL decoupling
VP2	14	2nd supply voltage TV-processor (+8V)
DECDIG	15	decoupling digital supply of TV-processor
PH2LF	16	phase-2 filter
PH1LF	17	phase-1 filter
GND3	18	ground 3 for TV-processor
DECBG	19	bandgap decoupling
AVL/EWD ⁽¹⁾	20	Automatic Volume Levelling/East-West drive output
VDRB	21	vertical drive B output
VDRA	22	vertical drive A output
IFIN1	23	IF input 1
IFIN2	24	IF input 2
IREF	25	reference current input
VSC	26	vertical sawtooth capacitor
TUNERAGC	27	tuner AGC output
AUDEEM/SIFIN1 ⁽¹⁾	28	audio deemphasis or SIF input 1
DECSDEM/SIFIN2 ⁽¹⁾	29	decoupling sound demodulator or SIF input2
GND2	30	ground 2 for TV processor
SNDPLL/SIFAGC ⁽¹⁾	31	narrow band PLL filter/AGC sound IF
AVL/SNDIF/REFO/ AMOUT ⁽¹⁾	32	Automatic Volume Levelling/sound IF input/subcarrier reference output/AM output
HOUT	33	(non controlled)
FBISO	34	horizontal output
AUDEXT/ QSSO/AMOUT ⁽¹⁾	35	flyback input/sand castle output
EHTO	36	external audio input/QSS intercarrier out/AM audio output (non controlled)
PLLIF	37	EHT/overvoltage protection input
IFVO/SVO	38	IF-PLL loop filter
VP1	39	IF video output/selected CVBS output
CVBSINT	40	main supply voltage TV-processor (+8V)
GND1	41	internal CVBS input
CVBS/Y	42	ground 1 for TV-processor
CHROMA	43	external CVBS/Y input
AUDOUT/AMOUT ⁽¹⁾	44	chrominance input (SVHS)
INSSW2	45	2nd RGB/YUV insertion input
R2/VIN	46	2nd R input/V (R-Y) input
G2/YIN	47	2nd G input/U input

SERVICE MANUAL

SYMBOL	PIN	DESCRIPTION
B2/UIN	48	2nd B input/U (B-Y) input
BCLIN	49	beam current limiter input/(V-guard input, note2)
BLKIN	50	black current input/(V-guard input, note2)
RO	51	Red output
GO	52	Green output
BO	53	Blue output
VDDA	54	analog supply of Teletext decoder and digital supply of TV-processor (3.3V)
VPE	55	OTP programming Voltage
VDDC	56	digital supply to core (3.3V)
OSCGND	57	oscillator ground supply
XTALIN	58	crystal oscillator input
XTALOUT	59	crystal oscillator output
RESET	60	reset
VDDP	61	digital supply to periphery (+3.3V)
P1.0/INT1	62	port 1.0 or external interrupt 1 input
P1.1/TO	63	port 1.1 or Counter/Timer 0 input
P1.2/INT0	64	port 1.2 or external interrupt 0 input

Notes

- 1)The function of pin 20, 28, 29, 31, 32, 35 and 44 is dependent on the IC version (mono intercarrier FM demodulator/QSS IF amplifier and East-West output or not) and on some software control bits. The valid combinations are given in table 2.
- 2)The vertical guard function can be controlled via pin 49 or pin 50. The selection is made by means of the IVG bit in subaddress 2BH.

Table 2 Pin functions for various versions

IC version	FM-PLL Version				QSS Version					
	N		Y		N			Y		
East-West Y/N										
CMB1/CM BO bits	00	01/10/11	00	01/10/11	00	01/10/11		00	01/10/11	
AM bit	-	-	-	-	-	0	1	-	0	1
Pin 20	AVL		EWD		AVL			EWD		
Pin 28	AUDEEM				SIFIN1					
Pin 29	DECSDEM				SIFIN2					
Pin 31	SNDPLL				SIFAGC					
Pin 32	SNDIR ⁽¹⁾	REFO ⁽²⁾	AVL/SNDIF ⁽¹⁾	REFO ⁽²⁾	AMOUT	REFO ⁽²⁾		AMOUT	REFO ⁽²⁾	
Pin 35	AUDEXT				AUDEXT	QSSO	AMOUT	AUDEXT	QSSO	AMOUT
Pin44	AUDOUT				Controlled AM or audio out					

Notes

- 1)When additional(external) selectivity is required for FM-PLL system pin 32 can be used as sound IF input. This function is selected by means of SIF bit in subaddress 28H.
- 2)The reference output signal is only available for the CMB1/CMBO setting of 0/1. For the other settings this pin is a switch output.

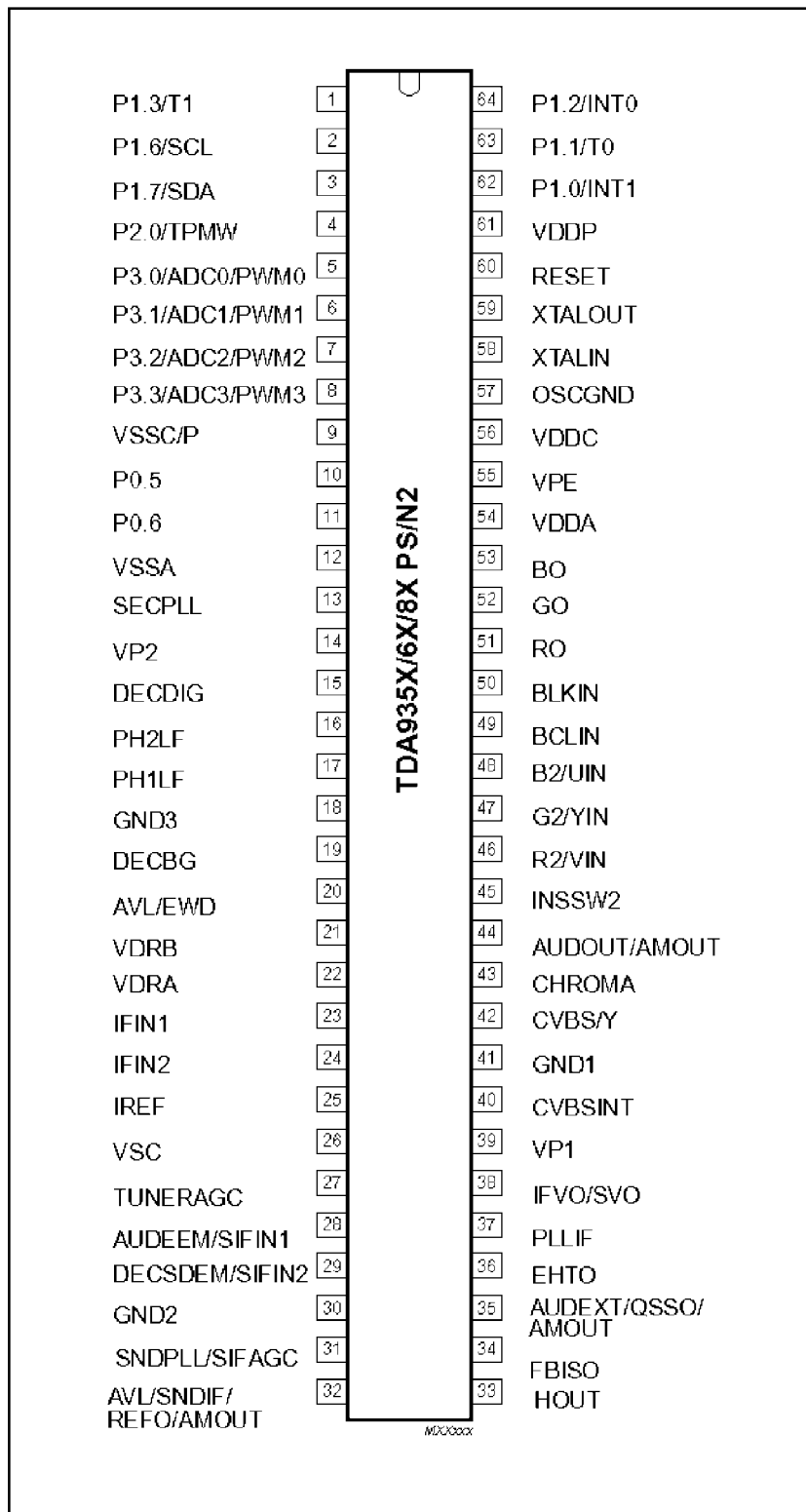

Fig.8 Pin Configuration (SDIP 64)

1.2 Electronic switch circuit HEF4053

Triple 2-channel Analog Multiplexer/Demultiplexer

1). Description

The HEF4053 is a triple 2-channel analog multiplexer/demultiplexer with a common enable input (\bar{E}). Each multiplexer/demultiplexer has two independent inputs/outputs (Y_0 and Y_1), a common input/output (Z), and select inputs (S_n). Each also contains two-bidirectional analog switches, each with one side connected to an independent input/output (Y_0 and Y_1) and the other side connected to a common input/output (Z). With (\bar{E}) LOW, one of the two switches is selected

(low impedance ON-state) by S_n . With \bar{E} HIGH, all switches are in the high impedance OFF-state, independent of S_A to S_C .

V_{DD} and V_{SS} are the supply voltage connections for the digital control inputs (S_A to S_C and \bar{E}). The V_{DD} to V_{SS} range is 3 to 15V. The analog inputs/outputs (Y_0 , Y_1 and Z) can swing between V_{DD} as a positive limit and V_{EE} as a negative limit. $V_{DD}-V_{EE}$ may not exceed 15 V. For operation as a digital multiplexer/demultiplexer, V_{EE} is connected to V_{SS} (typically ground).

2). Block Diagrams

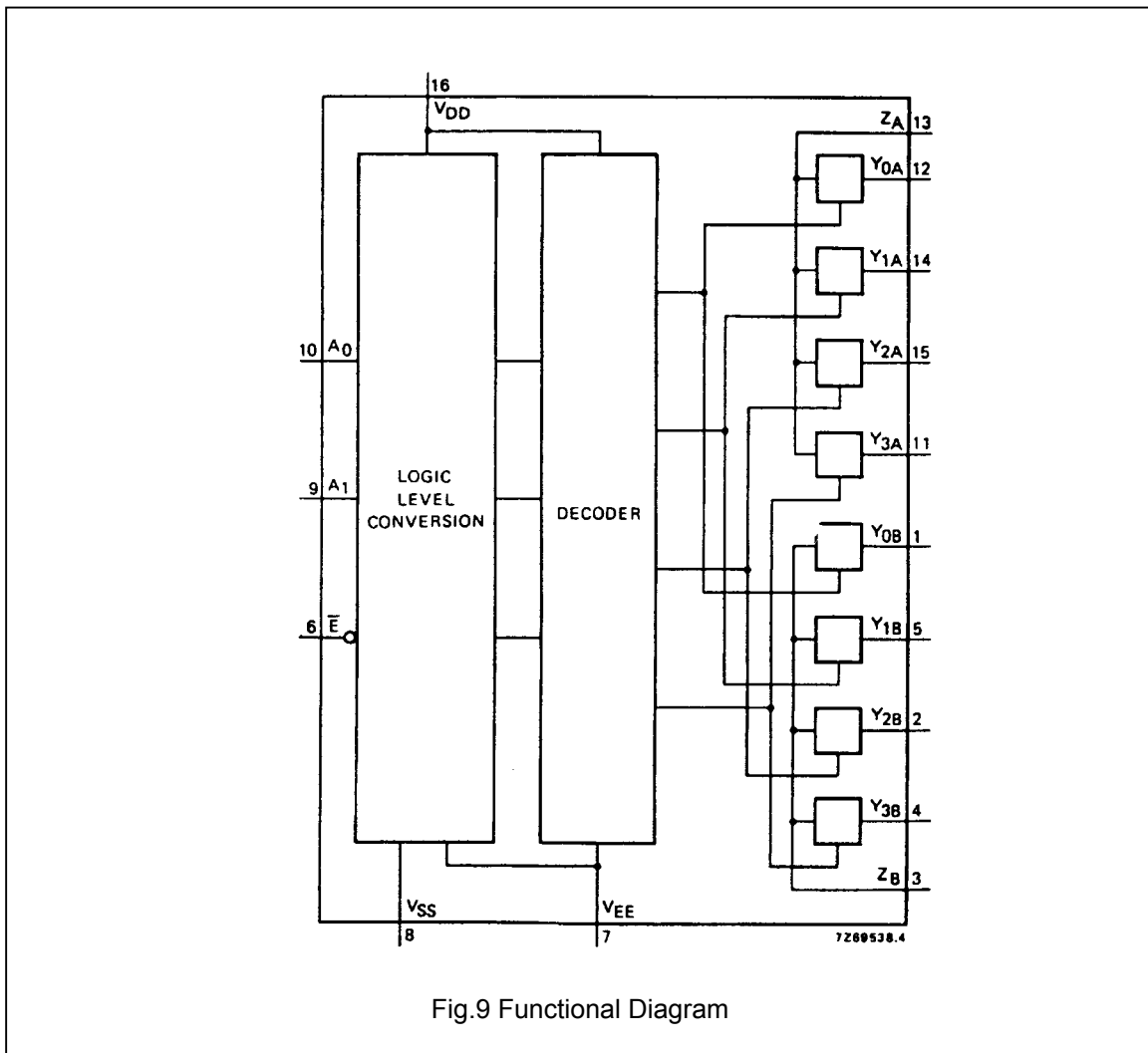

Fig.9 Functional Diagram

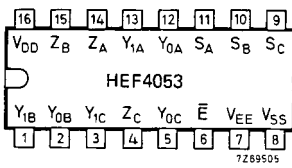

Fig. 10 Pinning Diagram

HEF4053P(N): 16-lead DIL; plastic (SOT38-1)

HEF4053D(F): 16-lead DIL; ceramic (cerdip) (SOT74)

HEF4053T(D): 16-lead S0; plastic (SOT109-1)

(): Package Designator North America

Pinning

Y_{0A} to Y_{0C}	Independent inputs/outputs
Y_{1A} to Y_{1C}	Independent inputs/outputs
S_A to S_C	Select inputs
E	Enable input (active LOW)
Z_A to Z_C	Common inputs/outputs

3. Function Table

Inputs		Channel
E	Sn	On
L	L	Y_{0n} - Z_n
L	H	Y_{1n} - Z_n
H	X	none

Notes

- H=HIGH state (the more positive voltage)
- L=LOW state (the less positive voltage)
- X=STATE is immaterial

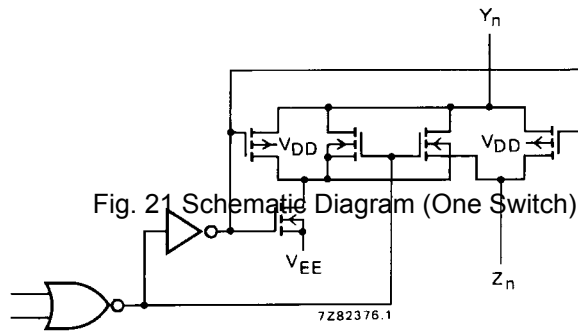

Fig 11

Ratings

Limiting values in accordance with the Absolute Maximum System (IEC 134)

Supply voltage (with reference to V_{DD}) V_{EE} -18 to +0,5 V

Note

To avoid drawing V_{DD} current out of terminal Z, when switch current flows into terminals Y, the voltage drop across the bidirectional switch must not exceed 0,4 V. If the switch current flows into terminal Z, no V_{DD} current will flow out of terminals Y, in this case there is no limit for the voltage drop across the switch, but the voltages at Y and Z may not exceed V_{DD} or V_{EE} .

1.3 Sound power amplifier TDA7057AQ

2x8W Stereo BTL Audio Output Amplifier with DC Volume Control

1). Features

- DC volume control
- Few external components
- Mute mode
- Thermal protection
- Short-circuit proof
- No switch-on and switch-off clicks
- Good overall stability
- Low power consumption
- Low HF radiation
- ESD protected on all pins.

2). General Description

The TDA7057AQ is a stereo BTL output amplifier with DC volume control. The device is designed for use in TVs and monitors, but is also suitable for battery-fed portable recorders and radios.

Missing Current Limiter (MCL)

A MCL protection circuit is built-in. The MCL circuit is activated when the difference in current between the output terminal of each amplifier exceeds 100 mA (typical 300 Ma). This level of 100 mA allows for single-ended headphone applications.

3). Block Diagram

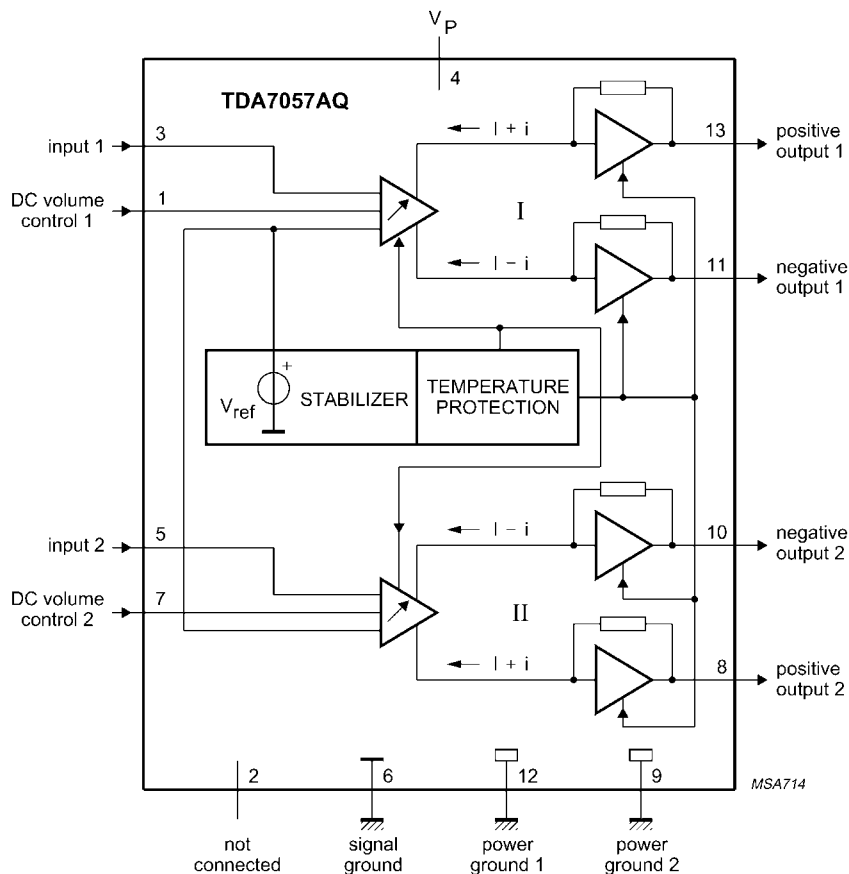

Fig.12

1.4 Vertical scan output stage circuit TDA8356/N6

DC-coupled vertical deflection circuit TDA8356

1) Features

- Few external components
- Highly efficient fully DC-coupled vertical output bridge circuit
- Vertical flyback switch
- Guard circuit
- Protection against:
 - Short-circuit of the output pins (7 and 4)
 - Short-circuit of the output pins to VP.
 - Temperature protection
 - High EMC immunity because of common mode inputs
 - A guard signal in zoom mode.

2) General Description

The TDA8356 is a power circuit for use in 90, and 110, colour deflection systems for field frequencies of 50 to 120 Hz. The circuit provides a DC driven vertical deflection output circuit, operating as a highly efficient class G system.

3) Block Diagram

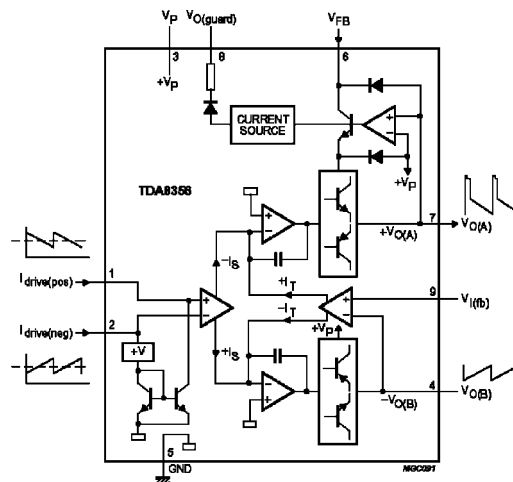

Fig.13

4) Pinning

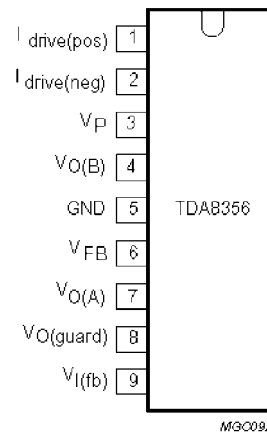

Fig.14

SYMBOL	PIN	DESCRIPTION
I drive(pos)	1	input power-stage (positive); includes I _l (sb) signal bias
I drive(neg)	2	input power-stage (negative); includes I _l (sb) signal bias
VP	3	operating supply voltage
VO(B)	4	output voltage B
GND	5	ground
VFB	6	input flyback supply voltage
VO(A)	7	output voltage A
VO(guard)	8	guard output voltage
VI(fb)	9	input feedback voltage

1.5 Audio effect processor TDA7449

TDA7449 TONE CONTROL DIGITALLY CONTROLLED AUDIO PROCESSOR INPUT MULTIPLEXER

1) Features

- 2 stereo inputs
- selectable input gain for optimal Adaptation to different sources One stereo output Treble, and bass control in 2.0db Steps Volume control in 1.0db steps Two speaker attenuators:
- two independent speaker control In 1.0db steps for balance facility
- independent mute function All function are programmable via Serial bus

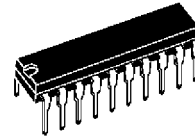

DIP20

2) description

ORDERING NUMBER: TDA7449

The tda7449 is a volume tone (bass and treble) Balance (left/right) processor for quality audio Applications in TV systems.

Selectable input gain is provided. Control of all The functions is accomplished by serial bus.

The ac signal setting is obtained by resistor networks And switches combined with operational Amplifiers.

Thanks to the used bipolar/cmotechnology, Low distortion, low noise and dc stepping are Obtained.

3) Block Diagram

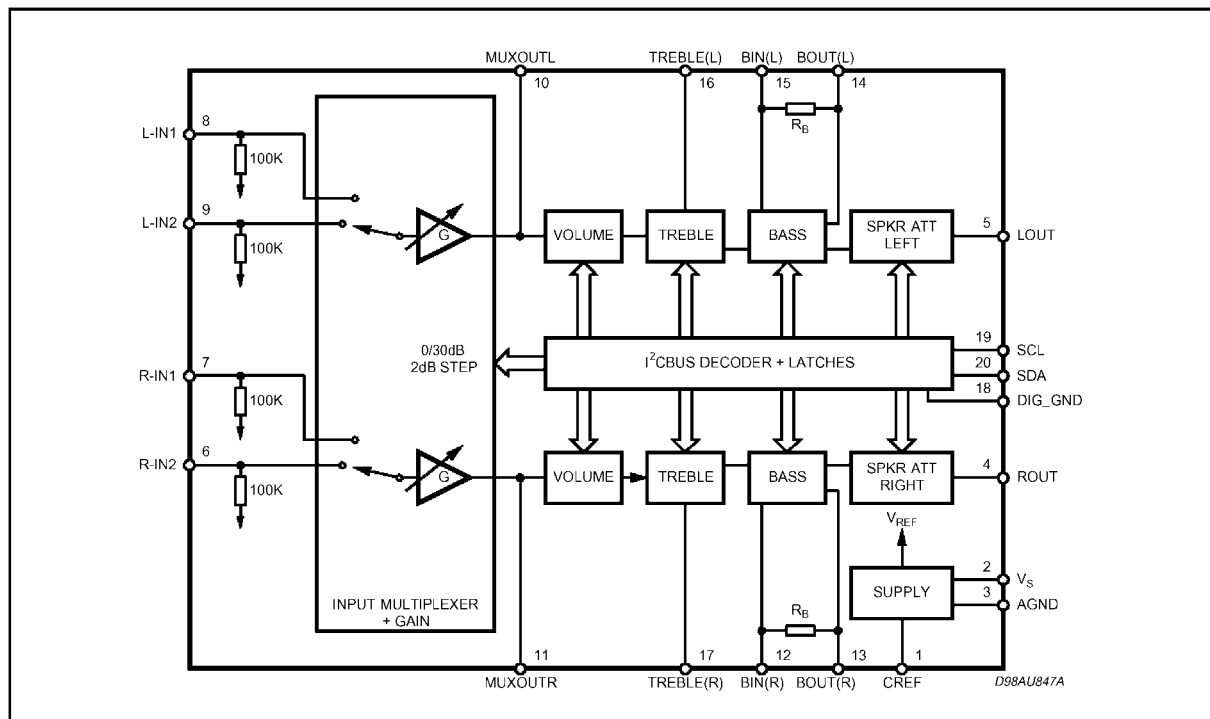

Fig.15

4) Pin Connection

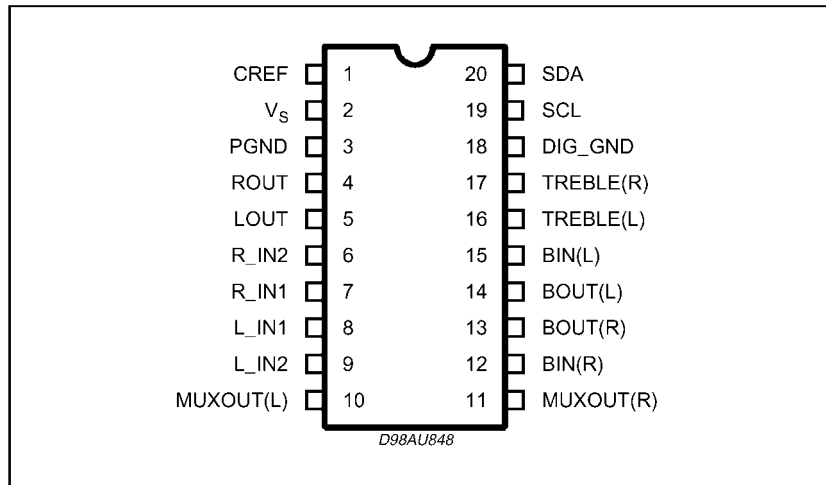

Fig.16

5) Electrical Characteristics

Symbol	Parameter	Test Condition	Min.	Typ.	Max.	Unit
AUDIO OUTPUTS						
V _{CLIP}	Clipping Level	d=0.3%	2.1	2.6		V _{RMS}
R _L	Output Load Resistance		2			K Ω
R _o	Output Impedance		10	4.0	70	Ω
V _{DC}	DC Voltage Level			3.8		V
GENERAL						
E _{NO}	Output Noise	All gains=0dB; BW=20Hz to 20KHz flat		5	15	μ V
E _t	Total Tracking Error	Av=0to-24dB		0	1	dB
		Av=-24to-47dB		0	2	dB
S/N	Signal to Noise Ratio	All gains 0dB; V _o =1V _{RMS} ;		106		dB
S _c	Channel Separation Left/Right		80	100		dB
d	Distortion	Av=0; V ₁ =1V _{RMS} ;		0.01	0.08	%
BUS INPUT						
V _{IL}	Input Low Voltage				1	V
V _{IH}	Input High Voltage		3			V
I _{IN}	Input Current	V _{IN} =0.4V	-5		5	μ V
V _o	Output Voltage SDA Acknowledge	I _o =1.6mA		0.4	0.8	V

SERVICE MANUAL

ELECTRICAL CHARACTERISTICS (refer to the test circuit Tamb = 25°C, VS = 9V, RL= 10K ,
RG = 600 , all controls flat (G = 0dB), unless otherwise specified)

Symbol	Parameter	Test Condition	Min.	Typ.	Max.	Unit
SUPPLY						
VS	Supply Voltage		6	9	10.2	V
IS	Supply Current			7		mA
SVR	Ripple Rejection		60	90		dB
INPUT STAGE						
RIN	Input Resistance			100		KΩ
VCL	Clipping Level	THD = 0.3%	2	2.5		Vrms
SIN	Input Separation	The selected input is grounded through a 2.2mF capacitor	80	100		dB
Ginmin	Minimum Input Gain		-1	0	1	dB
Ginmax	Maximum Input Gain			30		dB
Gstep	Step Resolution			2		dB
VOLUME CONTROL						
CRANGE	Control Range		45	47	49	dB
AVMAX	Max. Attenuation		45	47	49	dB
ASTEP	Step Resolution		0.5	1	1.5	dB
EA	Attenuation Set Error	AV = 0 to -24dB	-1.0	0	1.0	dB
		AV = -24 to -47dB	-1.5	0	1.5	dB
ET	Tracking Error	AV = 0 to -24dB		0	1	dB
		AV = -24 to -47dB		0	2	dB
VDC	DC Step	adjacent attenuation steps from 0dB to AV max		0 0.5	3	mv mv
Amute	Mute Attenuation		80	100		dB
BASS CONTROL (1)						
Gb	Control Range	Max. Boost/cut	±12.0	±14.0	±16.0	dB
BSTEP	Step Resolution		1	2	3	dB
RB	Internal Feedback Resistance		18.75	25	31.25	KΩ
TREBLE CONTROL (1)						
Gt	Control Range	Max. Boost/cut	±13.0	±14.0	±15.0	dB
TSTEP	Step Resolution		1	2	3	dB
SPEAKER ATTENUATORS						
CRANGE	Control Range			76		dB
SSTEP	Step Resolution		0.5	1	1.5	dB
EA	Attenuation Set Error	AV = 0 to -20dB	-1.5	0	1.5	dB
		AV = -20 to -56dB	-2	0	2	dB
VDC	DC Step	adjacent attenuation steps		0	3	mv
Amute	Mute Attenuation		80	100		dB

NOTE1:

- 1) The device is functionally good at Vs = 5V. a step down, on Vs, to 4V doesn't reset the device.
- 2) BASS and TREBLE response: The center frequency and the response quality can be chosen by the external circuitry.

1.6 EEPROM AT24C08

1) Features

- Data EEPROM internally organized as 1024/2048 bytes and 64/128 pages×16 bytes
- Page protection mode, flexible page-by-page hardware write protection
 - Additional protection EEPROM of 64/128 bits, bit per data page
 - 1-Protection setting for each data page by writing its protection bit
 - Protection management without switching WP pin
- Low power CMOS
- Vcc=2.7 to 5.5V operation
- Two wire serial interface bus, I²C-Bus compatible
- Filtered inputs for noise suppression with Schmitt trigger
- Clock frequency up to 400 kHz
- High programming flexibility
 - Internal programming voltage
 - Self timed programming cycle including erase
 - Byte-write and page-write programming, between 1 and 16 bytes
 - Typical programming time 6ms(<10ms) for up to 16 bytes
- High reliability
 - Endurance 10⁶ cycles¹⁾
 - Data retention 40 years¹⁾
 - ESD protection 4000 V on all pins
- 8 pin DIP/DSO packages
- Available for extended temperature ranges
 - Industrial: -40 to +85
 - Automotive: -40 to +125

2) Pin Configuration

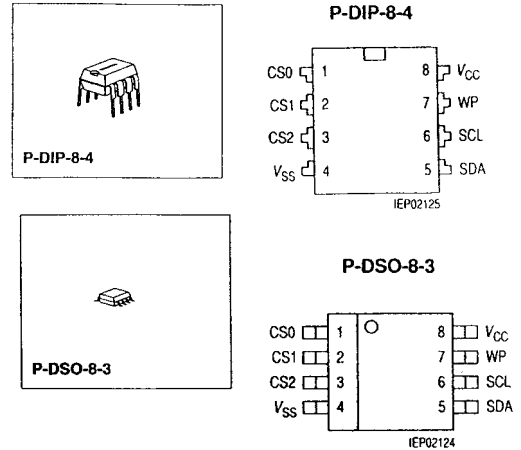

3) Block Diagram

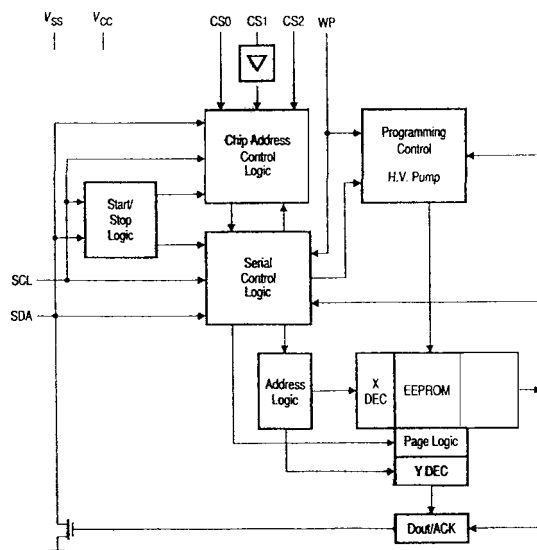

Fig. 17

1.7 Power module STR-G5653/6454R

Switch-mode Power Supply STR- G5653/F6654

The Series STR-G5653/F6654 is specifically designed to satisfy the requirements for increased integration and reliability in off-line quasi-resonant flyback converters. The series incorporates a high-precise error amplifying control and drive circuit with discrete avalanche-rated power MOSFET, featuring fewer external components, small-size and standard power supply.

Covering the power range from below 25 watts up to 300 watts for 100/115/230 VAC inputs, and up to 150 watts for 85 to 265 VAC universal input, these devices can be used in a range of applications, from battery chargers and set top boxes, to televisions, monitors, and industrial power supply units. Cycle-by-cycle current limiting, under-voltage lockout with hysteresis, over-voltage protection, and thermal shutdown protects the power supply during the normal overload and fault conditions.

Low-current startup and a low-power standby mode selected from the secondary circuit completes a comprehensive suite of features. The series is provided in a five-pin overmolded SIP style package, affording dielectric isolation without compromising thermal characteristics.

1) Features

- Flyback Operation with Quasi-Resonant Soft Switching for Low Power Dissipation and EMI
- Rugged Avalanche-Rated MOSFET
- Soft drive circuit MOSFET
- Adjustable MOSFET switching speed
- Choice of MOSFET Voltage and $r_{DS(on)}$
- Full Over-Current Protection (no blanking)
- Under-Voltage Lockout with Hysteresis
- Over-Voltage Protection
- Direct Voltage Feedback
- Low Start-up Current ($100 \mu A_{max}$)
- Low-Frequency, Low-Power Standby Operation
- Overmolded 5-Pin Package

2). Circuit Block Diagram

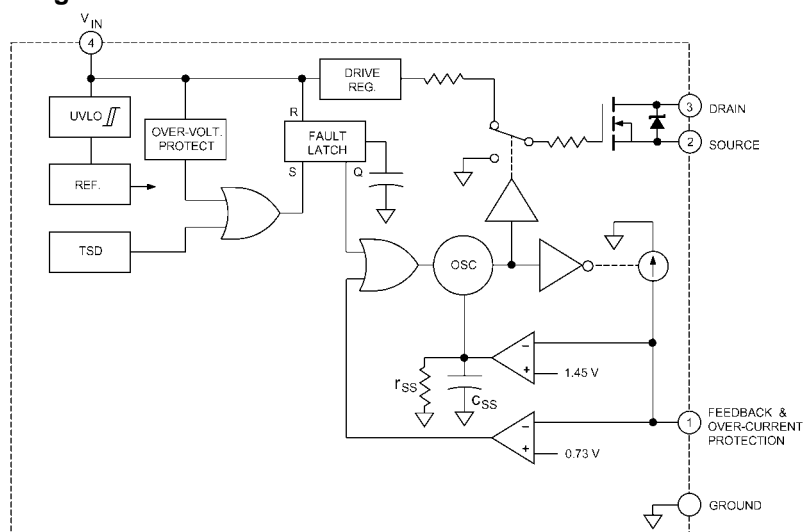

Fig.18

3). Pin Configuration and Functions

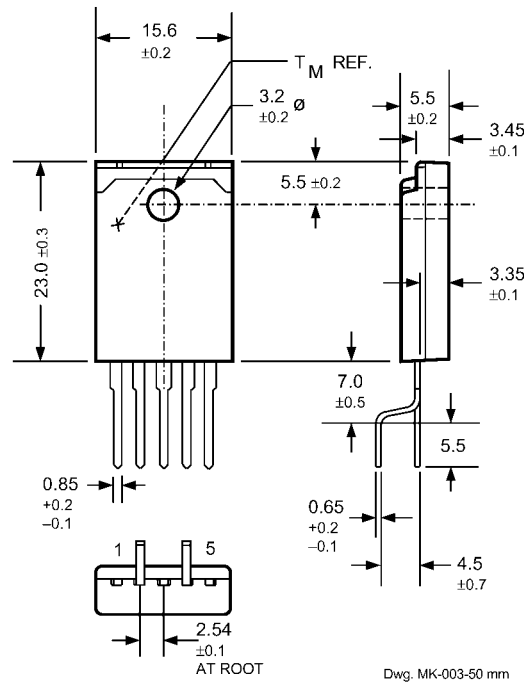

Fig.19

3.1) Pin function for STR-G5653

Pin No.	Symbol	Function Description
1	D	MOSFET drain
2	S	MOSFET source
3	GND	Ground
4	V _{IN}	Supply voltage input for control circuit
5	OCP/FB	Over-current protection detection signal/ voltage-limiting signal input

3.2) Pin function for STR-F6654

Pin No.	Symbol	Function Description
1	OCP/FB	Over-current protection detection signal/ voltage-limiting signal input
2	S	MOSFET source
3	D	MOSFET drain
4	V _{IN}	Supply voltage input for control circuit
5	GND	Ground

4). Difference between STR-G5653 and STR-F6654

- Different size: STR- F6654 is larger
- Different pin functions
- Different electric characteristics: Larger power output, switching current, avalanche-rated and internal allowable power consumption for STR-F6654
- internal allowable power consumption for STR-F6654

3. WAVEFORMS OF KEY POINTS

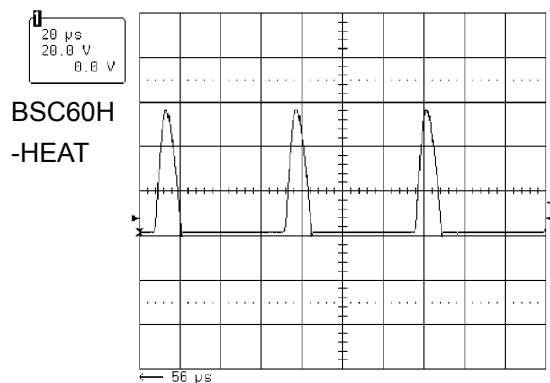
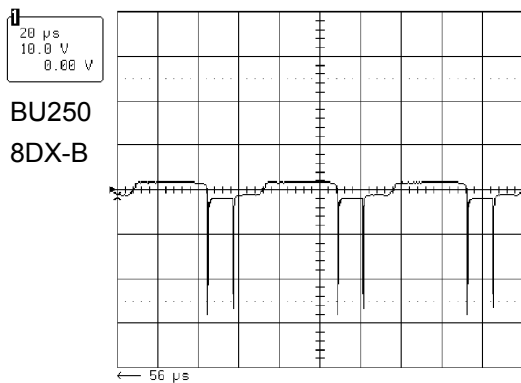
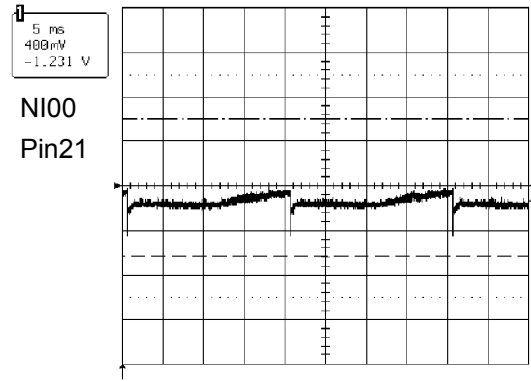
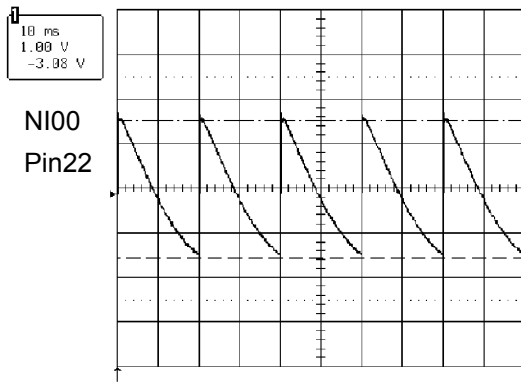
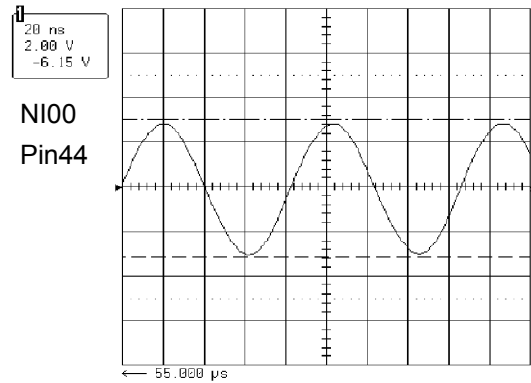
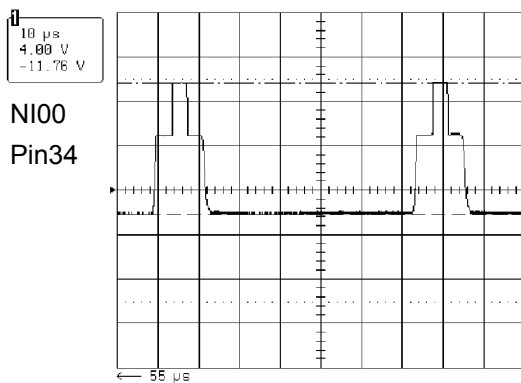
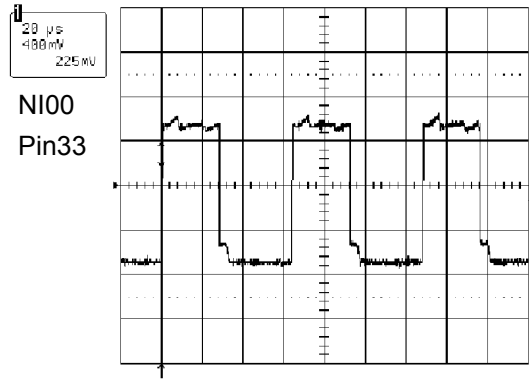
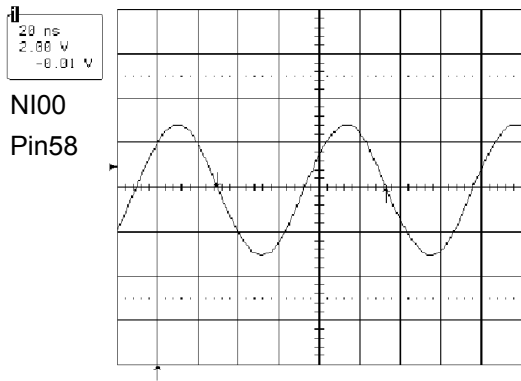

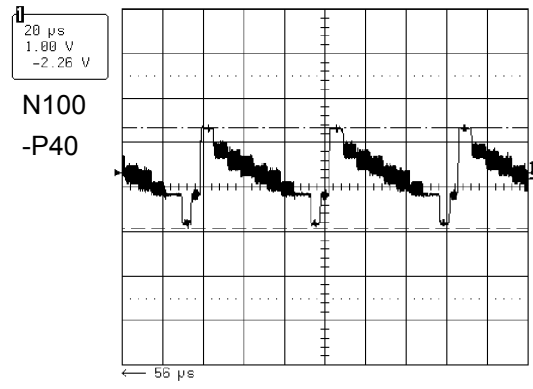
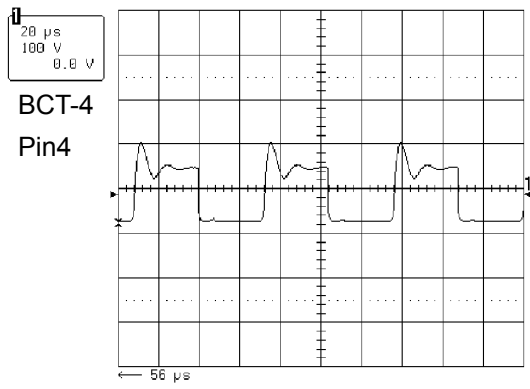

Notes:

The waveforms are only for reference.

The waveforms may differ dependent on different models.

4. KEY ICS SERVICE DATA

Table 3 Function and Service Data of TDA7057AQ (N600)'s Pins

Pin No.	Function description	Digital Multimeter : Victor DT890D		
		Reference Voltage (V)	Positive Resistance (K)	Negative Resistance (K)
1	Vertical drive input (positive)	7.5	22.6	18.6
2	Vertical drive input (negative)	0	0	0.
3	Feedback input	7.5	22.6	18.6
4	Supply voltage	7.5	22.6	18.6
5	Output 1	0	0	0
6	Not connected	7.5	22.6	18.6
7	Ground	0.8	8.7	8.8
8	Pump supply voltage input	0	0	0.
9	Output 1	2.4	54.7	23.6
10	Guard output	16.0	2.4	2.4
11	Pincushion output	2.4	55.1	23.6
12	Pincushion input (negative)	0	-	-
13	Pincushion input (positive)	0.8	9.0	8.8

Table 4 Function and Service Data of TDA8356 (N401)'s Pins

Pin No.	Symbol	Digital Multimeter : Victor DT890D		
		Reference Voltage (V)	Positive Resistance (K)	Negative Resistance (K)
1	Idrive (pos)	2.4	27.7	20.3
2	Idrive (neg)	2.4	27.7	20.4.
3	VP	15.4	26.3	13.5
4	VO (B)	7.7	6.1	6.1
5	GND	0	0	0
6	VFB	45.0	113.3	13.7
7	VO (A)	7.5	6.1	6.1
8	VO(guard)	0.2	10.0	9.7.
9	VI(fb)	7.7	6.1	6.1

Table 5 Function and Service Data of HEF4053BP (N402)'s Pins

Pin No.	Function description	Digital Multimeter : Victor DT890D		
		Reference Voltage (V)	Positive Resistance (K)	Negative Resistance (K)
1	Signal input	3.0	22.2	47.0
2	Signal input	3.9	22.2	47.0.
3	Signal input	1.3	21.2	40.0
4	Signal output	2.5	0	0
5	Signal input	2.4	-	-

(continued)

SERVICE MANUAL

6	Ground	0	0	0
7	Ground	0	0	0
8	Ground	0	0	0.
9	Control signal input	0.03	13.5	13.1
10	Control signal input	0.03	13.5	13.1
11	Control signal input	0.03	13.5	13.1
12	Signal input	3.9	22.2	47.0
13	Signal output	0.7	22.2	47.0
14	Signal input	3.9	21.9	26.0
15	Audio output	3.9	21.9	26.0
16	Supply voltage	7.8	0	0

Table 6 Function and Service Data of TDA7449 (N650)'s Pins

Pin No.	Symbol	Digital Multimeter : Victor DT890D		
		Reference Voltage (V)	Positive Resistance (K)	Negative Resistance (K)
1	CREF	4.0	28.2	21.9
2	VS	8.0	1.8	1.8
3	PGND	0	0	0
4	ROUT	3.3	9.4	9.3
5	LOUT	3.3	9.4	9.3
6	R_IN1	4.0	21.9	26.0
7	R_IN2	4.0	26.7	24.3.
8	L_IN1	4.0	26.7	24.3
9	L_IN2	4.0	21.9	26.1
10	MUXOUT(L)	4.0	24.5	22.5
11	MUXOUT(R)	4.0	24.5	22.5
12	BIN(R)	4.0	28.0	26.1
13	BOUT(R)	4.0	28.0	21.0
14	BOUT(L)	4.0	28.0	20.8
15	TREBLE(L)	4.0	28.0	26.1
16	BIN(L)	4.0	30.5	28.0
17	TREBLE(R)	4.0	30.5	28.0
18	DIG_GND	0	0	0
19	SCL	3.4	6.8	6.7
20	SDA	3.1	6.8	6.7

Table 7 Function and Service Data of TDA9351PS/N2/3I (N100)'s Pins

Pin No.	Symbol	Digital Multimeter : Victor DT890D		
		Reference Voltage (V)	Positive Resistance (K)	Negative Resistance (K)
1	P1.3/T1	3.8	9.5	9.5
2	P1.6/SCL	3.4	6.8	6.8

(continued)

SERVICE MANUAL

3	P1.7/SDA	3.0	6.8	6.8
4	P2.0/TPWM	1.8	36.2	17.9
5	P3.0/ADC0/PWM0	0.1	11.8	12.3
6	P3.1/ADC1/PWM1	0.1	5.0	5.0
7	P3.2/ADC2/PWM2	0.02	13.5	13.5
8	P3.3/ADC3/PWM3	0.7	10.7	9.3
9	VSSC/P	0	0	0
10	P0.5	0.01	13.3	13.3
11	P0.6	4.2	11.6	11.0
12	VSSA	0	0	0
13	SECPLL	2.3	27.6	21.7
14	VP2	8.0	1.8	1.8
15	DECDIG	5.0	23.1	16.1
16	PH2LF	3.2	27.5	21.0
17	PH1LF	3.9	27.9	21.2
18	GND3	0	0	0
19	DECBG	4.0	24.4	18.7
20	AVL/EWD (1)	0.01	27.6	21.2
21	VDRA	2.4	27.6	20.4
22	IFIN1	2.4	27.6	20.3
23	IFIN2	1.8	24.7	19.8
24	IREF	1.8	24.7	19.9
25	TUNERAGC	3.8	25.3	20.5
26	AUDEEM/SIFIN1(1)	3.8	27.7	21.5
27	DECSDM/SIFIN2(1)	1.6	8.4	8.4
28	GND2	3.2	27.1	20.7
29	VSSA	2.3	27.8	21.6
30	SECPLL	0	0	0
31	SNDPLL/SIFAGC(1)	2.3	27.8	21.8
32	AVL/SNDIF/REF0/AMOUT(1)	0.2	27.2	20.4
33	HOUT	0.4	5.3	5.3
34	FBISO	0.5	24.0	18.8
35	AUDEXT/QSSO/AMOUT(1)	3.7	27.8	21.5
36	AUDEXT/	1.6	18.7	16.0
37	QSSO/AMOUT(1)	2.4	27.8	21.5
38	AUDEXT/	3.3	24.0	21.1
39	QSSO/AMOUT(1)	7.7	1.8	1.8
40	AUDEXT/	3.8	27.5	21.2
41	GND1	0	0	0
42	CVBS/Y	3.3	27.5	21.2

(continued)

SERVICE MANUAL

43	CHROMA	1.4	26.8	20.9
44	AUDOUT /AMOUT(1)	3.3	27.5	21.5
45	INSSW2	1.6	1.0	1.0
46	R2/VIN	2.6	28.0	21.7
47	G2/YIN	2.6	28.0	21.7
48	B2/UIN	2.6	28.0	21.7
49	BCLIN	2.5	27.6	20.8
50	BLKIN	6.0	27.9	21.3
51	RO	2.6	1.1	1.1
52	GO	2.5	1.1	1.1
53	BO	2.4	1.1	1.1
54	VDDA	3.2	11.0	11.3
55	VPE	0	0	0
56	VDDC	3.2	11.0	11.3
57	OSCGND	0.02	-	-
58	XTALIN	-	-	-
59	XTALOUT	-	-	-
60	RESET	0	0	0
61	VDDP	3.2	11.0	11.3
62	P1.0/INT1	0	-	-
63	P1.1/T0	1.5	3.3	3.3
64	P1.2/INT0	5.0	18.2	17.5

Notes:

The data are only for reference.

The data sheet may differ dependent on different models.

4. REPLACEMENT OF PARTS

4.1 *Description*

Many electrical and mechanical components in this chassis have special safety-related characteristics. Components which have these special safety characteristics in this manual and its supplements are identified by the international hazard symbols or UL, FCC, FDA or VDE marking on the circuit diagram and parts list. When replacing any of these components, substitute the one which has the same safety characteristics as specified in the manual.

CIRCUIT DIAGRAM FOR 21C19/PF21C19

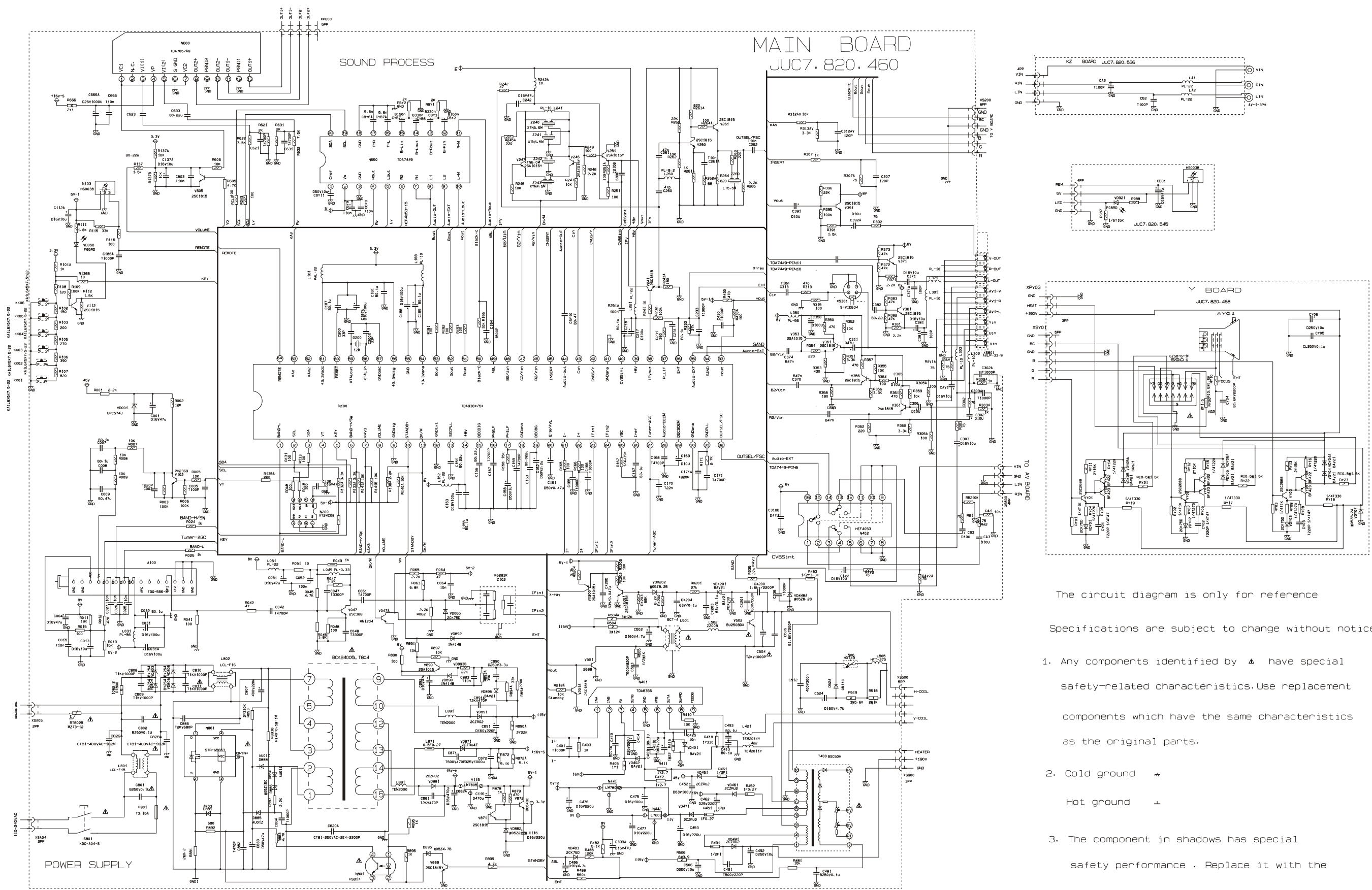

The circuit diagram is only for reference
 Specifications are subject to change without notice

1. Any components identified by ▲ have special safety-related characteristics. Use replacement components which have the same characteristics as the original parts.
2. Cold ground ≠
 Hot ground ⊥
3. The component in shadows has special safety performance. Replace it with the same specifications as the original's

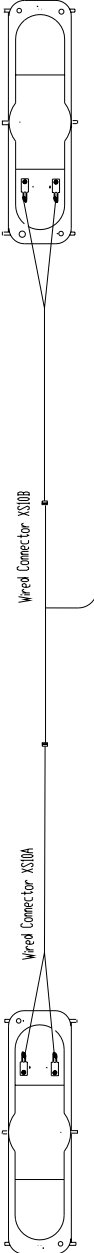
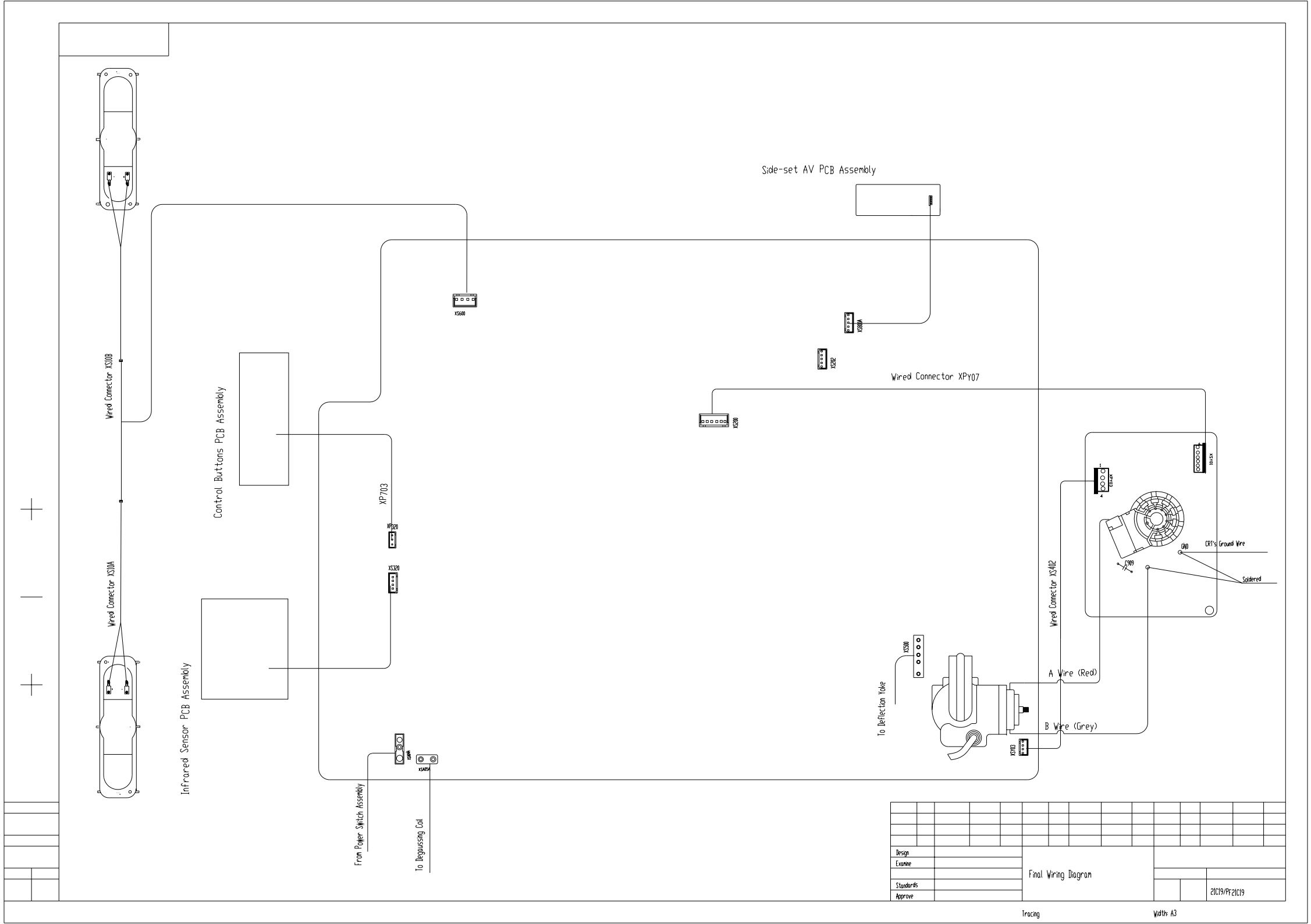

Infrared Sensor PCB Assembly

Control Buttons PCB Assembly

Side-set AV PCB Assembly

From Power Switch Assembly

To Debussing Coil

To Reflection Yoke

Design		Final Wiring Diagram		
Examine				
Standards				
Approve				
				21C19/PF21C19

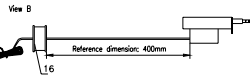
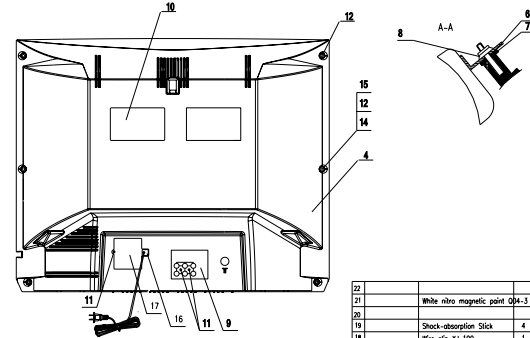
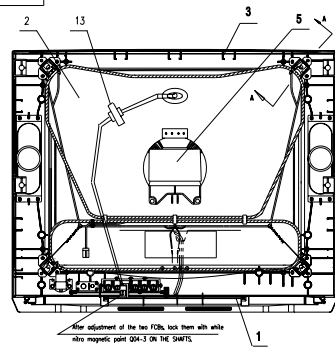

1. Install the CRT with fixing torque of 3.5--5N.m.
2. Insert the wired connector XS402, screen wire and focus wire together with the wire clip (T/U08.667.328).
Professional engineers decide the location depending on different situation.
After adjustment of the two FCBs, lock them with white nitro magnetic point Q04-3 on the shafts.
3. Connect wires according to the final wiring diagram and check if the wired connectors are connected correctly and fixedly, and the high voltage cap and CRT RGB PCB are mounted.
4. Tie the degaussing coil with the wire clip XJ-100(18) to make the wire far from high temperature components.
Reinstall the back cover after inspection and ensuring O.K.
5. Insert the wired clip A into the slot on the back cover, then install the cover board(17)
6. Check and make sure that all control buttons can work flexibly and normally.
and label plates are stuck fixedly.

22					
21					White nitro magnetic point Q04-3
20					
19					Shock-absorption Stick
18					Wire clip XJ-100
17					Cover board
16					Wire clip A
15					Flexiline
14					Seal cap
13					Distance clip
12					Tapping screw 4X200M4Ch
11					Tapping screw 3X120M4Ch
10					Rear plate
9					AV cable
8					M5 notched washer nut
7	T/U08.943.224				Washer
6	T/U08.942.249				Washer
5					CRT RGB PCB assembly
4					Back cover
3					Front cover assembly
2					CRT assembly
1					Main PCB assembly

Part No.	Code No.	Parts	Qty	Remarks

Design	Final Assembly Diagram			
Layout	Level	Mark	Weight	Protection
Process				
Standard	21C19/PF21C19			
Approve				

MAIN PCB

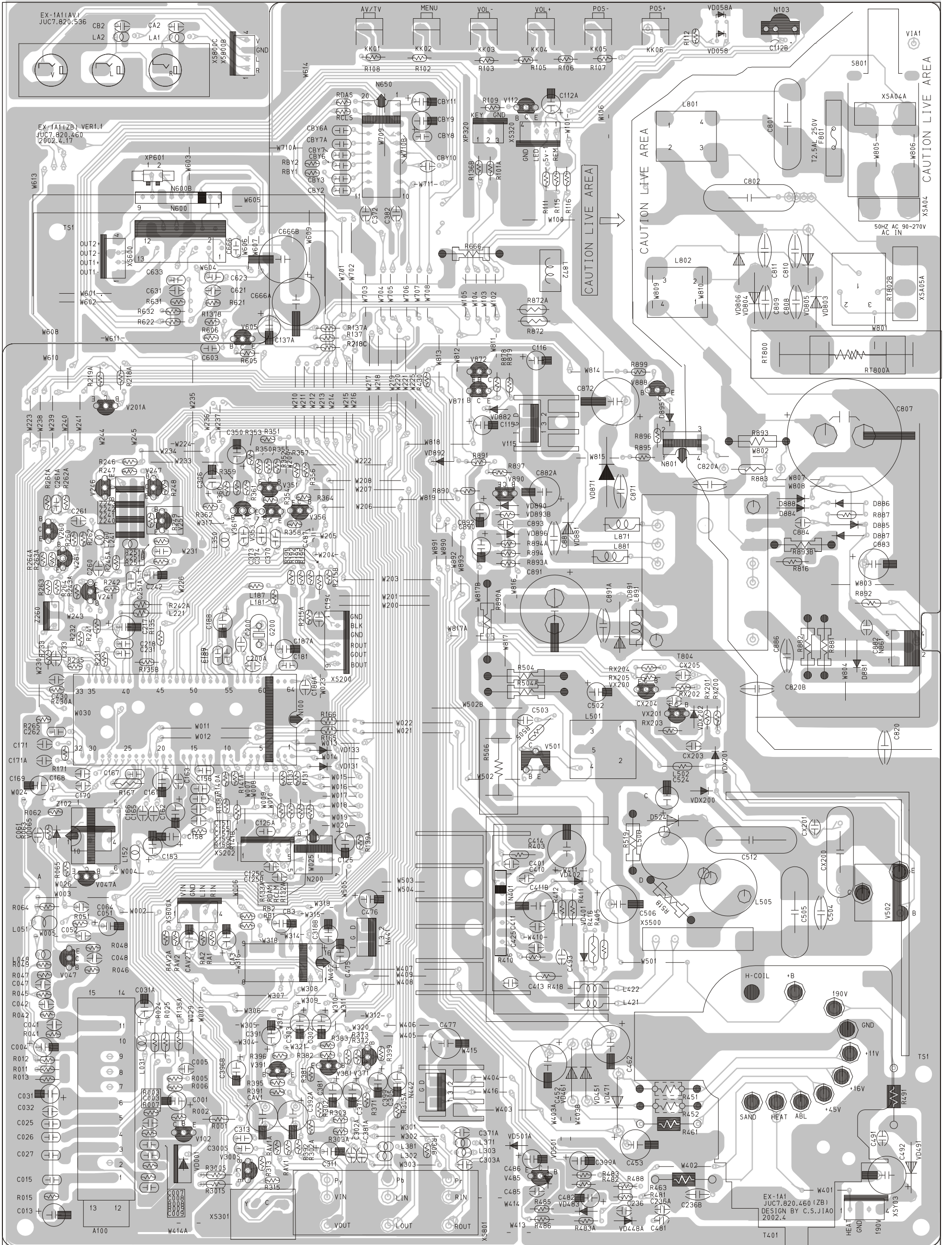

CRT RGB PCB

