

ONKYO SERVICE MANUAL

AV RECEIVER MODEL TX-SR308(B)(S)(G)

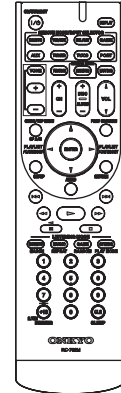
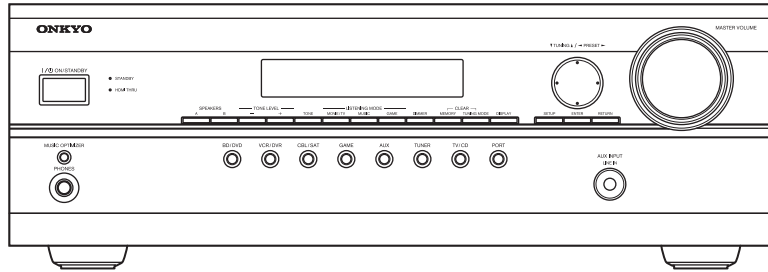

RC-762M

TX-SR308(B) : Black model

<MDC> : 120V, Canadian model

<MDD> : 120V, USA model

<MDF> : 120V, Taiwanese model

<MMO> : 220/230-240V, Saudi Arabian model

<MMQ> : 220/230-240V, Hong kong model

<MPA> : 230V, Australian model

<MPP> : 230V, CE(European) country model

TX-SR308(S) : Silver model

<MPP> : 230V, CE(European) country model

TX-SR308(G) : Golden model

<MMR> : 220/230-240V, Chinese model

SAFETY-RELATED COMPONENT WARNING!!

COMPONENTS IDENTIFIED BY MARK  ON THE SCHEMATIC DIAGRAM AND IN THE PARTS LIST ARE CRITICAL FOR RISK OF FIRE AND ELECTRIC SHOCK. REPLACE THESE COMPONENTS WITH ONKYO PARTS WHOSE PART NUMBERS APPEAR AS SHOWN IN THIS MANUAL.

MAKE LEAKAGE-CURRENT OR RESISTANCE MEASUREMENTS TO DETERMINE THAT EXPOSED PARTS ARE ACCEPTABLY INSULATED FROM THE SUPPLY CIRCUIT BEFORE RETURNING THE APPLIANCE TO THE CUSTOMER.

TROUBLE SHOOT-1 No Power

This is just for general reference and does not including every single case.

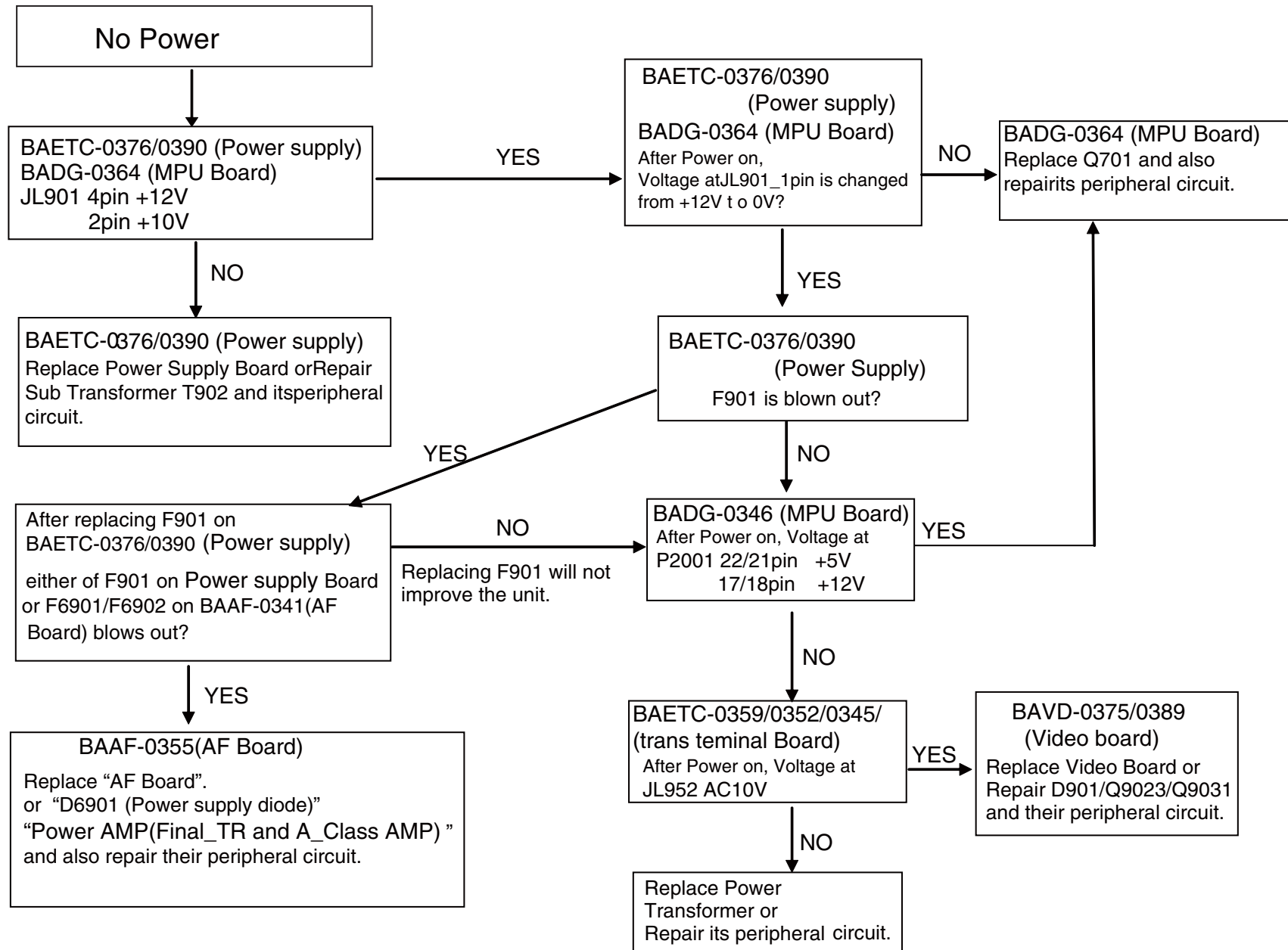

TROUBLE SHOOT- 2
No Display

This is just for general reference and does not include every single case.
The above waveforms are got by Oscilloscope of Maximum Horizontal Sensitivity: 100MHz.
The results depend on the oscilloscope.

1
2
3
4
5

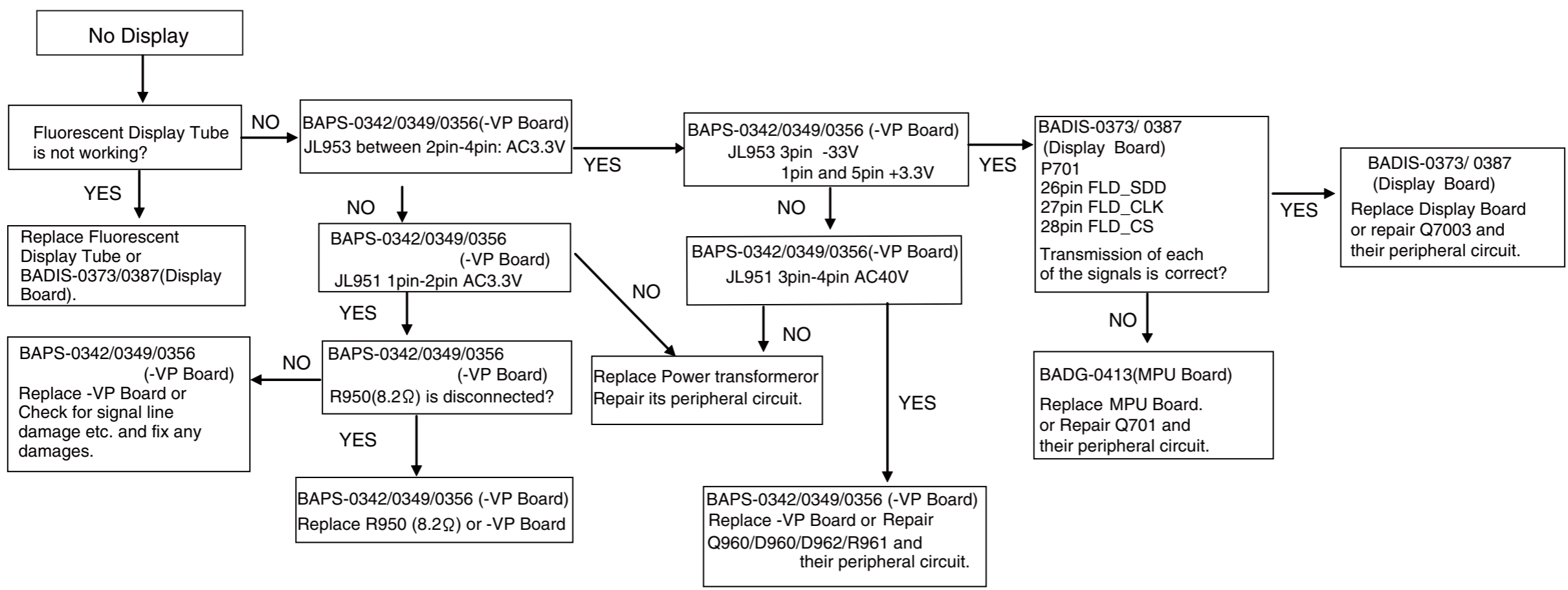

Timing of Serial Communication

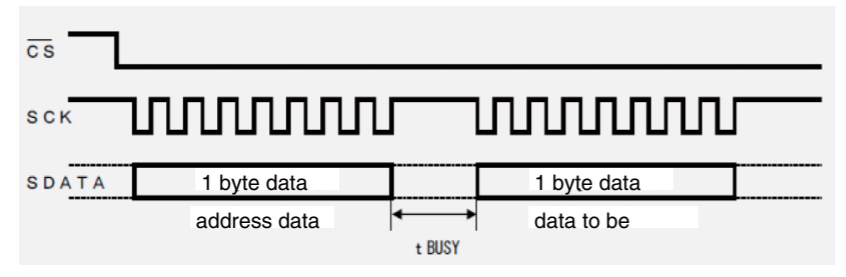

	FLD_CLK	FLD_SDD(DATA)	FLD_CS
V:1V/cm H:02Msec/cm			
V:1V/cm H:10µsec/cm			
V:1V/cm H:1µsec/cm			

TROUBLE SHOOT-3
No Sound

Note:
This is just for general reference and does not include every single case.
The above waveforms are got by Oscilloscope of Maximum Horizontal Sensitivity: 100MHz.
The results depend on the oscilloscope.

central lead wire of the resistance

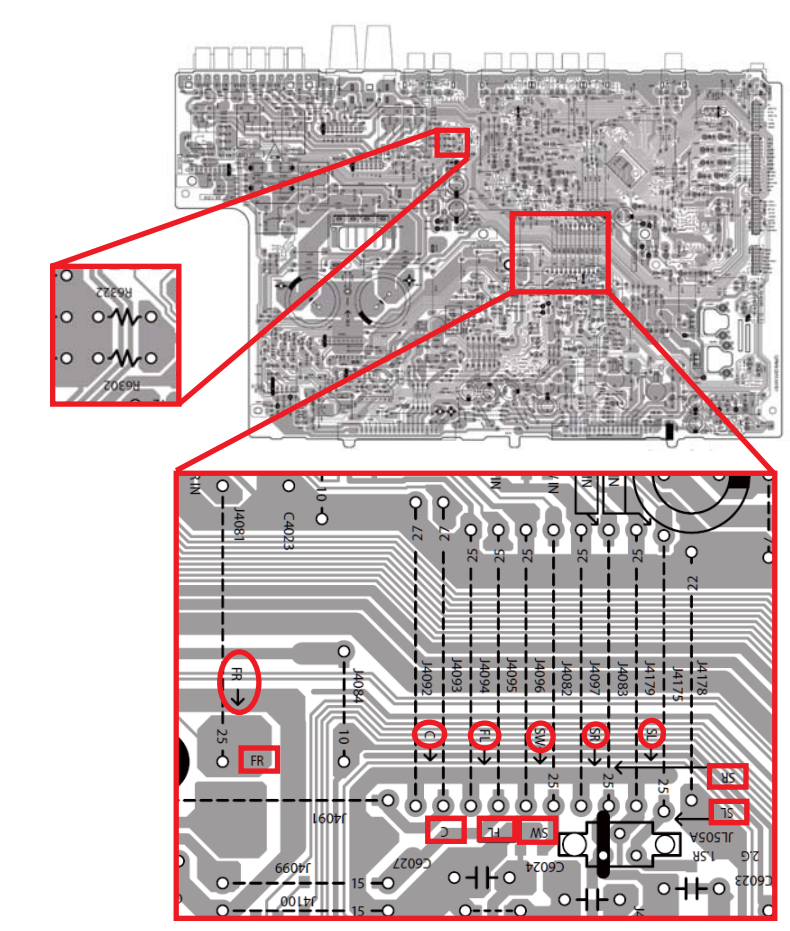
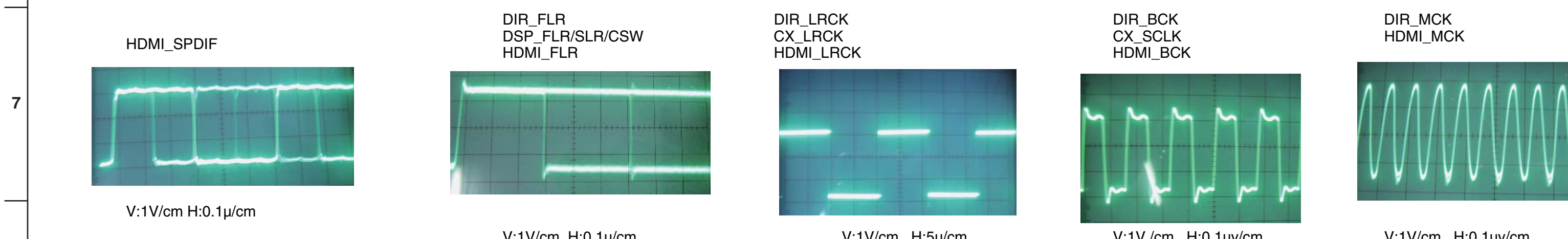
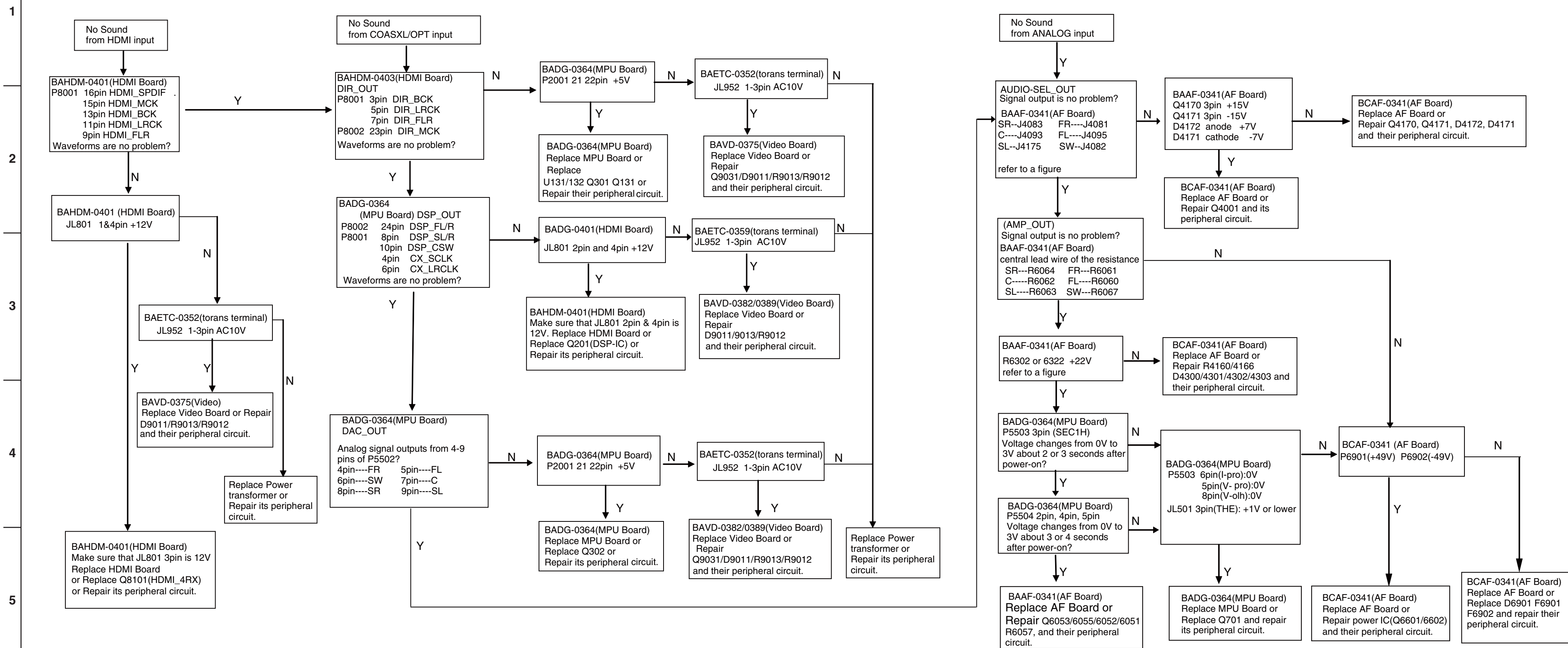

figure

TROUBLE SHOOT-4

No Pictuer

Note:

This is just for general reference and does not include every single case.

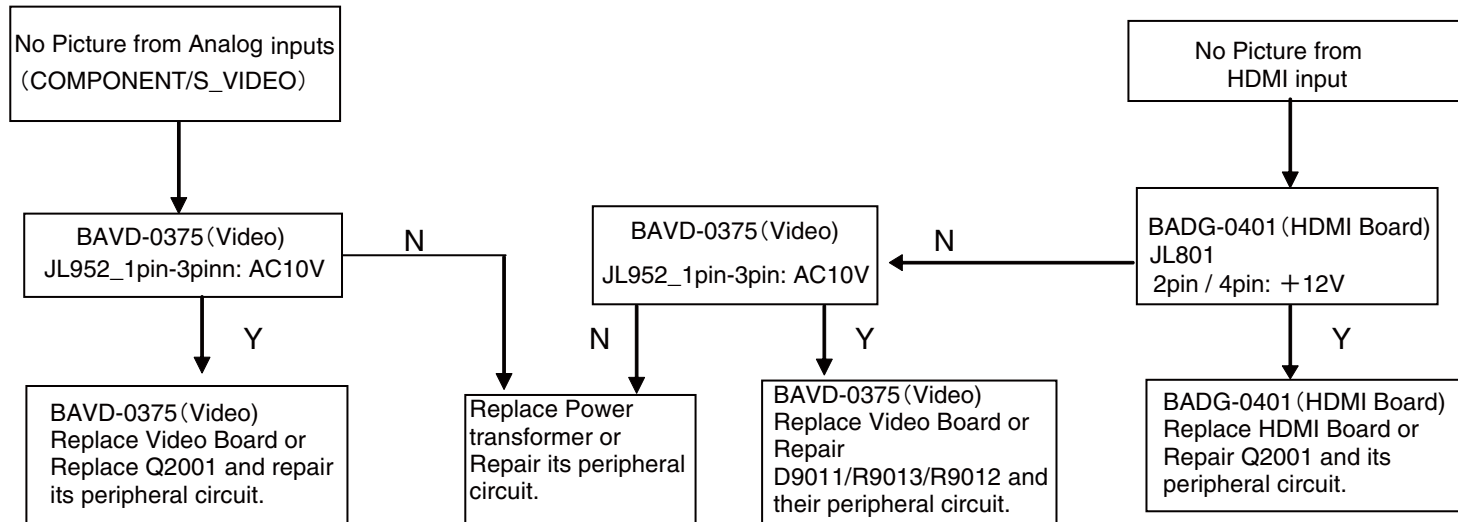

Reference materials

BLOCK DIAGRAMS (HDMI Video & Digital Audio Section)

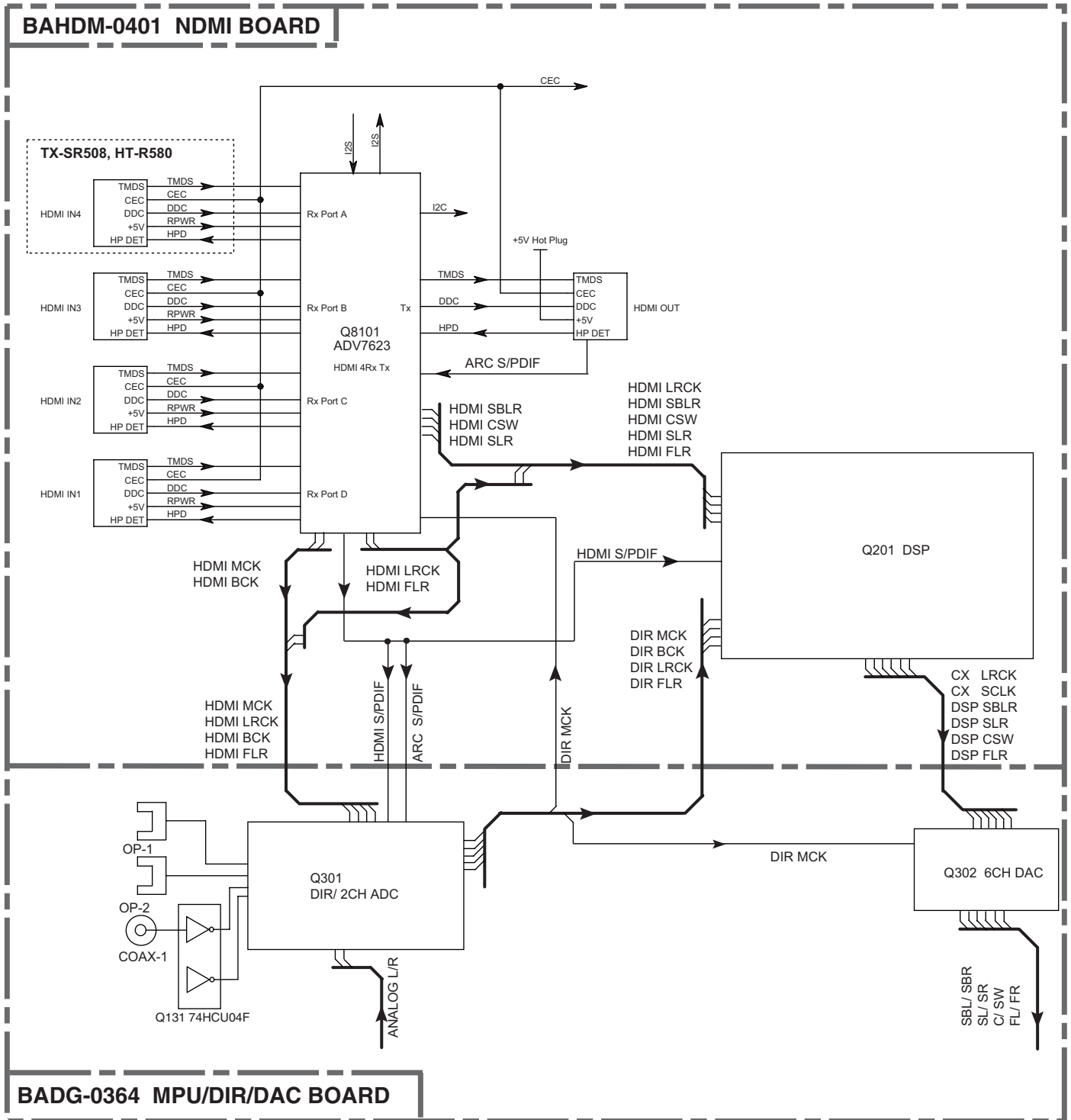

Reference materials, (protect detection)

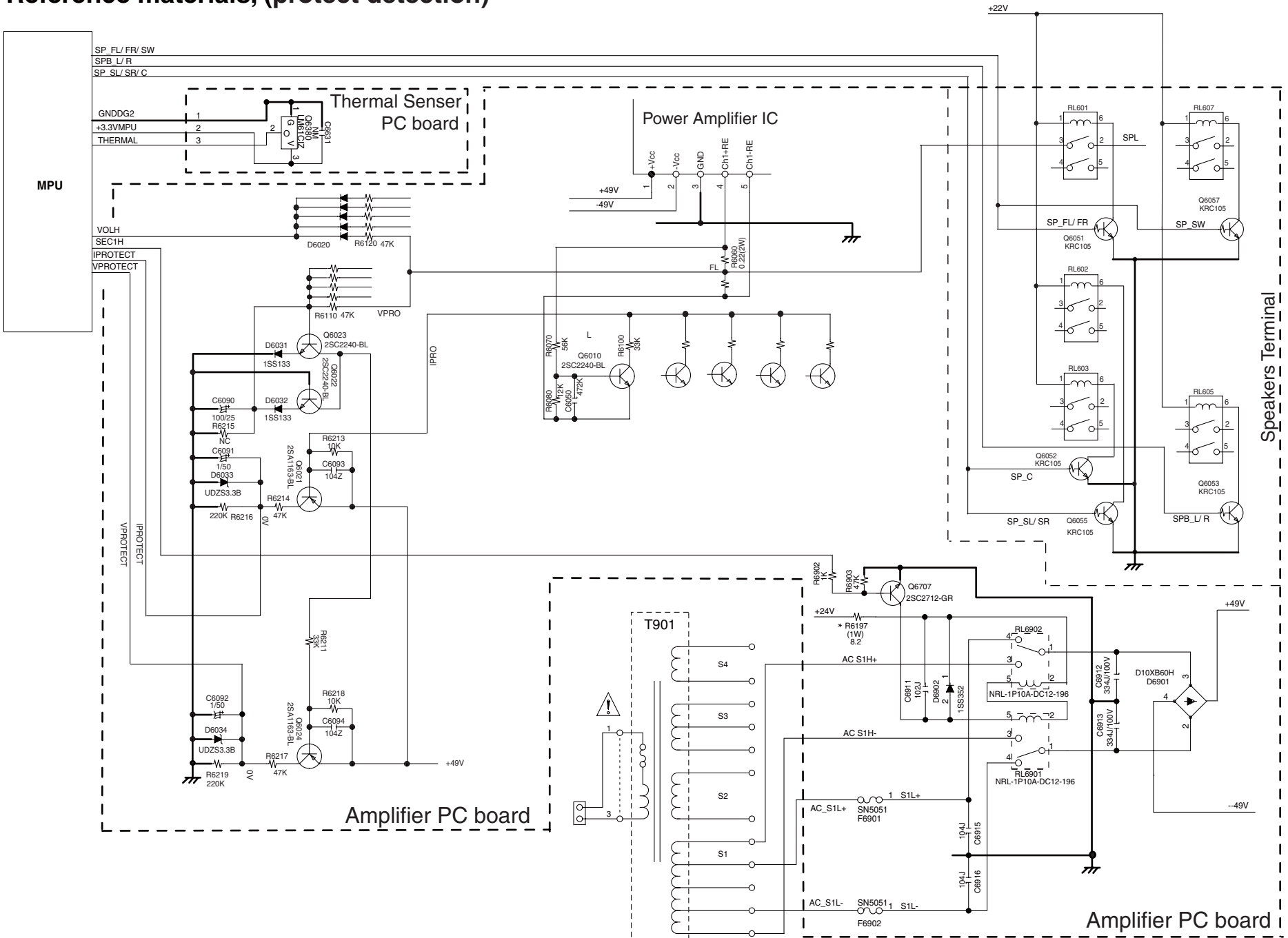

MAIN/DSP Update Procedure-1 (How to check FW Version)

[NOTE] FW version combination

- * OSD FW cannot be updated.
- * Combination of "OSD_FW and Main_FW" has limitation .
- * **Do not use combination except the list.**

FW Version Combination "As of September, 2010"

	Main	DSP	OSD	marking
1st Lot	1.04	1.00	1.00	NO
Later Lots	1.05	1.01	1.01	A
	1.06			B
	1.07			C
	1.08	1.02		D
	1.09			E

OSD menu will not appear. Before FW UPdate. check the versions of FWs.

marking is the S/N end

- * To upgrade OSD FW version,
Replace Q8105 SPI_MEMORY "EN25Q32A-100HIP" or HDMI Board.

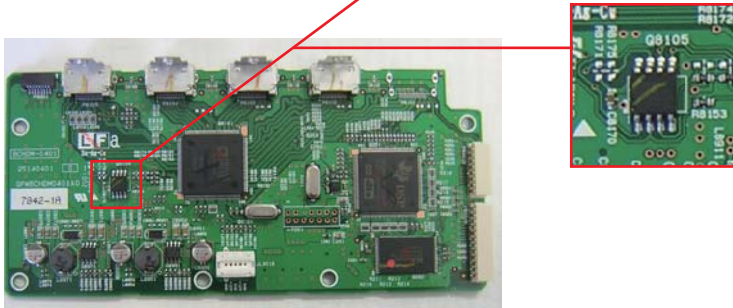

To check FW Versions on the monitor,

While the unit is on, hold down [DISPLAY] and the press [ON/STANDBY].
FW Versions of Main/DSP/OSD will be shown on the monitor like below.

Version Information	
Main:	1.07/10413AL
DSP:	1.02/10419a38
OSD:	1.01/10204A0
CHECKSUM:	27D3879D

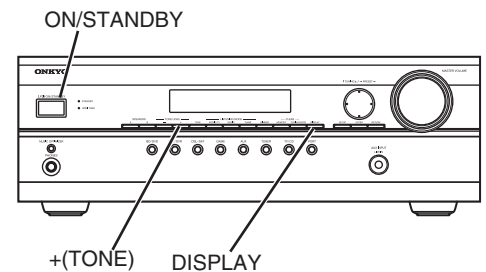

To check FW versions on Front Display,

1. While the unit is on, hold down [DISPLAY] and the press [ON/STANDBY].
Main FW Version will be shown on Front Display.
e.g. M:1.07/10413AL — * It depends on the version.
2. While Main FW Version is shown, press [+(TONE)].
DSP FW Version will be shown on Front Display.
e.g. D:1.02/10416a38 — * It depends on the version.

OSD FW Version will not be shown on Front Display.

MAIN/DSP Update Procedure-2

[NOTE: See MAIN/DSP Update Procedure-1]

*Combination of "MAIN_FW and OSD_FW" has limitation.

*OSD FW cannot be updated.

Preparation for Update

1. PC (Personal Computer) which can play back wav files and output digital audio signal under Windows XP.
2. Software: Given wav-formatted FW Store it in the PC in advance (PC Update) or burn a CD-R with it as a music disc (CD Update).
3. Connection: DIGITAL (OPTICAL/COAXIAL) ourput of PC/CD Player --> DIGITAL (OPTICAL-1/COAXIAL-1) INPUT of TX-SR608 etc.

* PC needs to be able to handle wav files and output digital audio signal.

* For wav-compatible PCs which do not output audio signal at the above specification, use a commercially-available USB-AUDIO interface unit. e.g. Onkyo-made ND-S1

* PC needs to run Windows XP. Windows Vista and Windows 7 do not work.

* Set wave Volume to Maximum including Volume Control in Control Panel.
For further information, please see Owner's manual of your PC.

Control Panel
--> Sounds and Audio Devices
--> Volume tab
--> Advanced
--> Turn all the levels to Max.

* Instead of PC, CD players with DIGITAL output terminal can be used.

Note: CD players need to output digital audio signal .

Some CD players and DVD players are not suitable for update because they process audio signal to output.

Burn a CD-R as music disc.

Connection Example

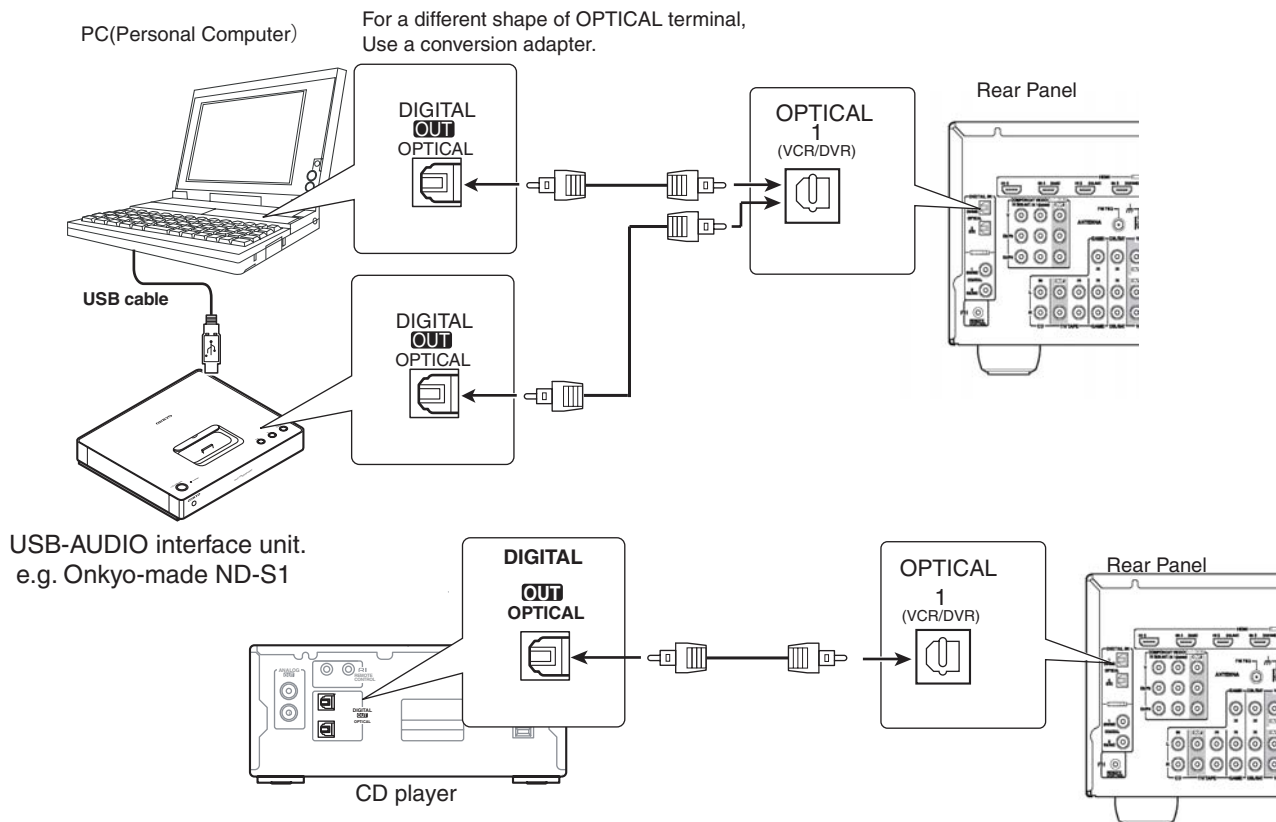

<NOTE 1>

"Writing" will not be shown even more than about 15 seconds passed after starting playback, audio signal does not output at Sampling frequency:44.1kHz. Check the connection and settings and try again. When another try results in failure again, use the other update method.

<NOTE 2>

DURING FW UPGRADE,DO NOT TURN OFF THE UNIT. DO NOT REMOVE ANY CONNECTIONS. These operation will not allow FW Upgrade any more, andthe whole board or IC will need replacing.

MAIN/DSP Update Procedure-3

Update Procedure

1. While the unit is on, hold down [DISPLAY] and then press [ON/STANDBY].
Main FW Version will be shown on Front Display.

e.g. M:1.07/10413AL — * It depends on the version.

2. While Main FW Version is shown, press [+(TONE)].
DSP FW Version will be shown on Front Display.

e.g. D:1.02/10416a38 — * It depends on the version.

3. While DSP FW Version is shown, press [RETURN].

TOTAL / AUTO

- * ◀TUNING▶ key changes "AUTO" ▶ "COAX1" ▶ "OPT1."
("AUTO" means "COAX1" or "OPT1" will be automatically detected.)
- * ▲TUNING▼ key changes "TOTAL"▼"MAIN"▼"DSP."
(TOTAL = MAIN+ DSP)

4. When MAIN and DSP FWs are upgraded at the same time, select "TOTAL / AUTO" and press "ENTER."
For separate upgrade, select "MAIN" or "DSP" and press "ENTER."

S/PDIF Update..

5. PC upgrade: Play back the stored wav file in your PC.
CD upgrade: Play back the FW CD-R with the connected CD player. It takes about 15 minutes.

[NOTE] Make sure that "PCM" is shown before starting playback.
About 15 seconds later, the message will change from **S/PDIF Update...** to **Writing...**
When "Writing..." will not be shown, the output music data is not correct.
Check the connection and settings.

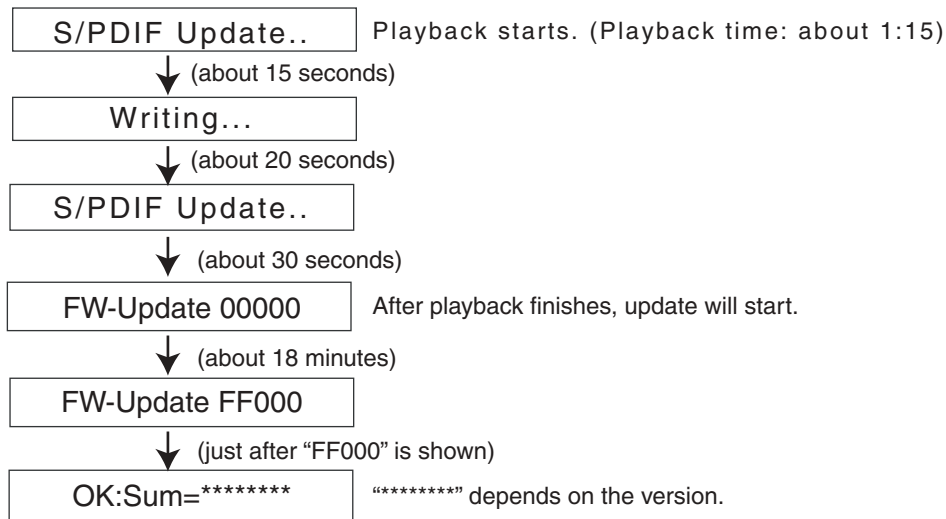

6. Unplug AC cord and plug it again. Press [ON/STANDBY].

Clear

7. Make sure that "Clear" is shown and the unit is turned into the Standby mode.
8. Make sure that the FW versions are the latest.

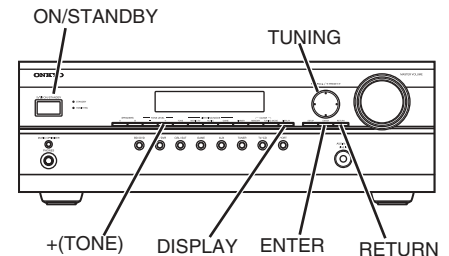

WIRING DIAGRAM

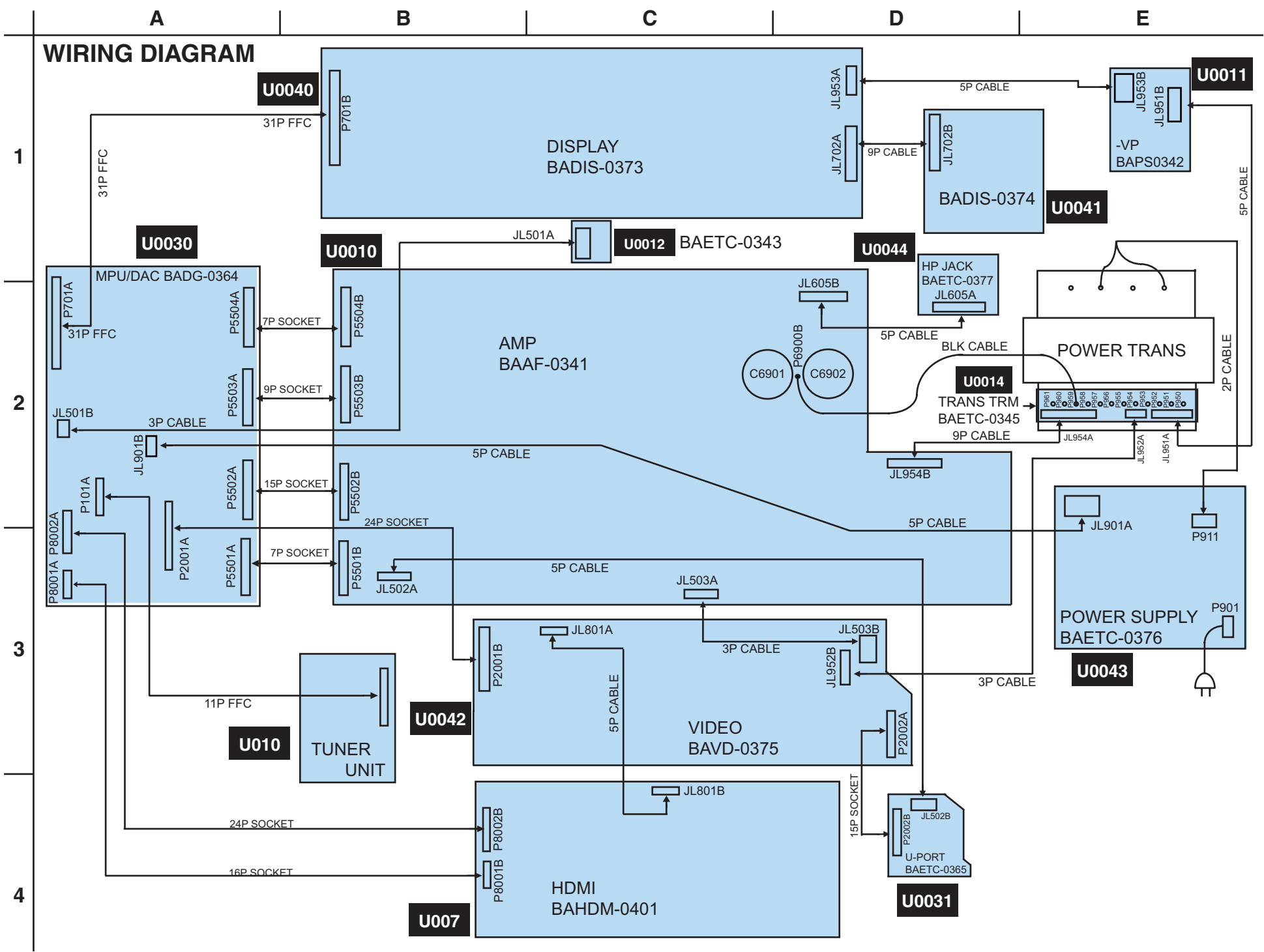

SCHEMATIC DIAGRAMS-1a
BLOCK DIAGRAM , AUDIO SECTION

AUDIO ANALOG SIGNAL(TV/CD) DIGITAL AUDIO SIGNAL(OPT-1)
FRONT L FRONT R

1
2
3
4
5
6
7
8

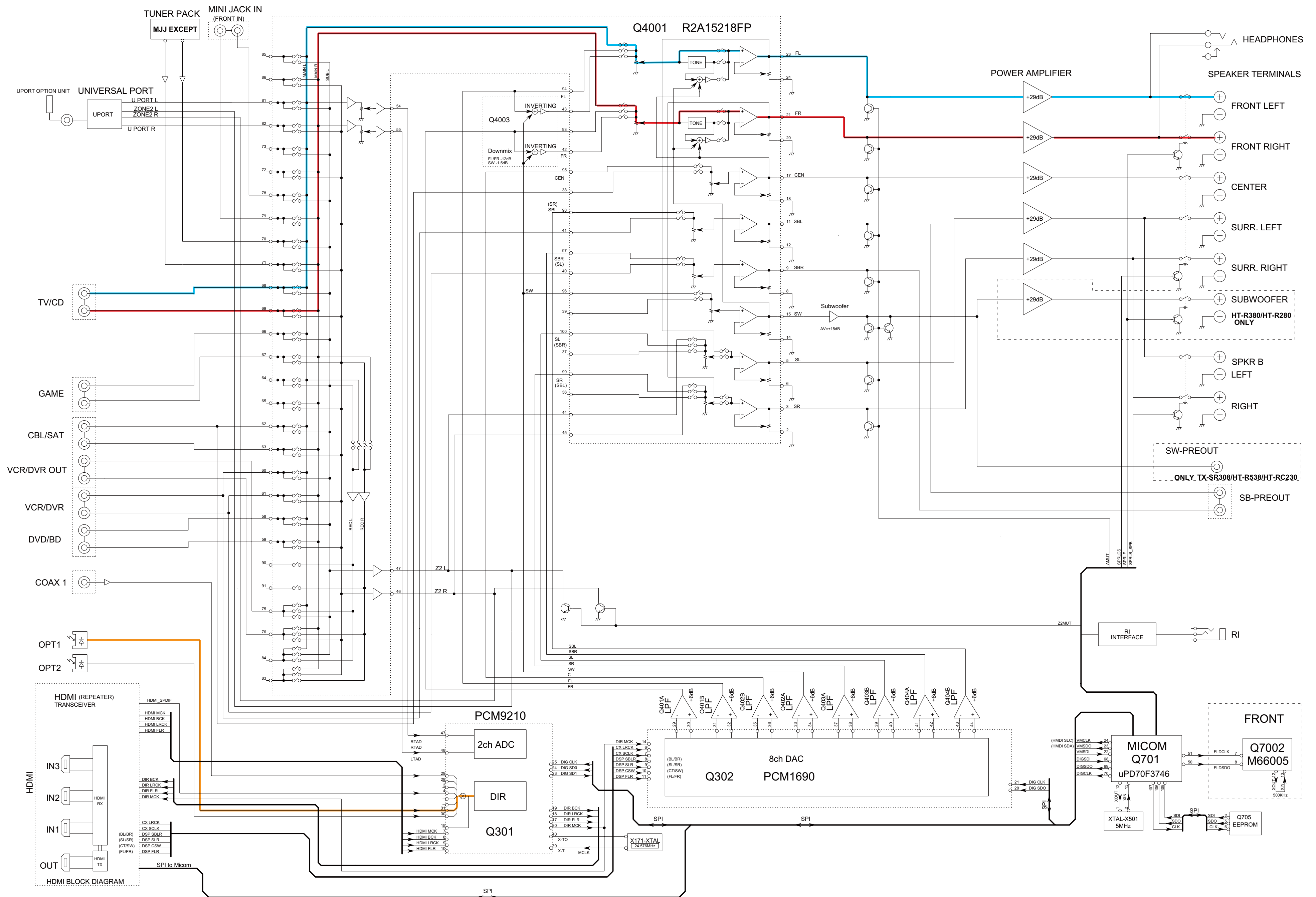

SCHEMATIC DIAGRAMS-2

Video BLK Section

1
2
3
4
5
6
7
8

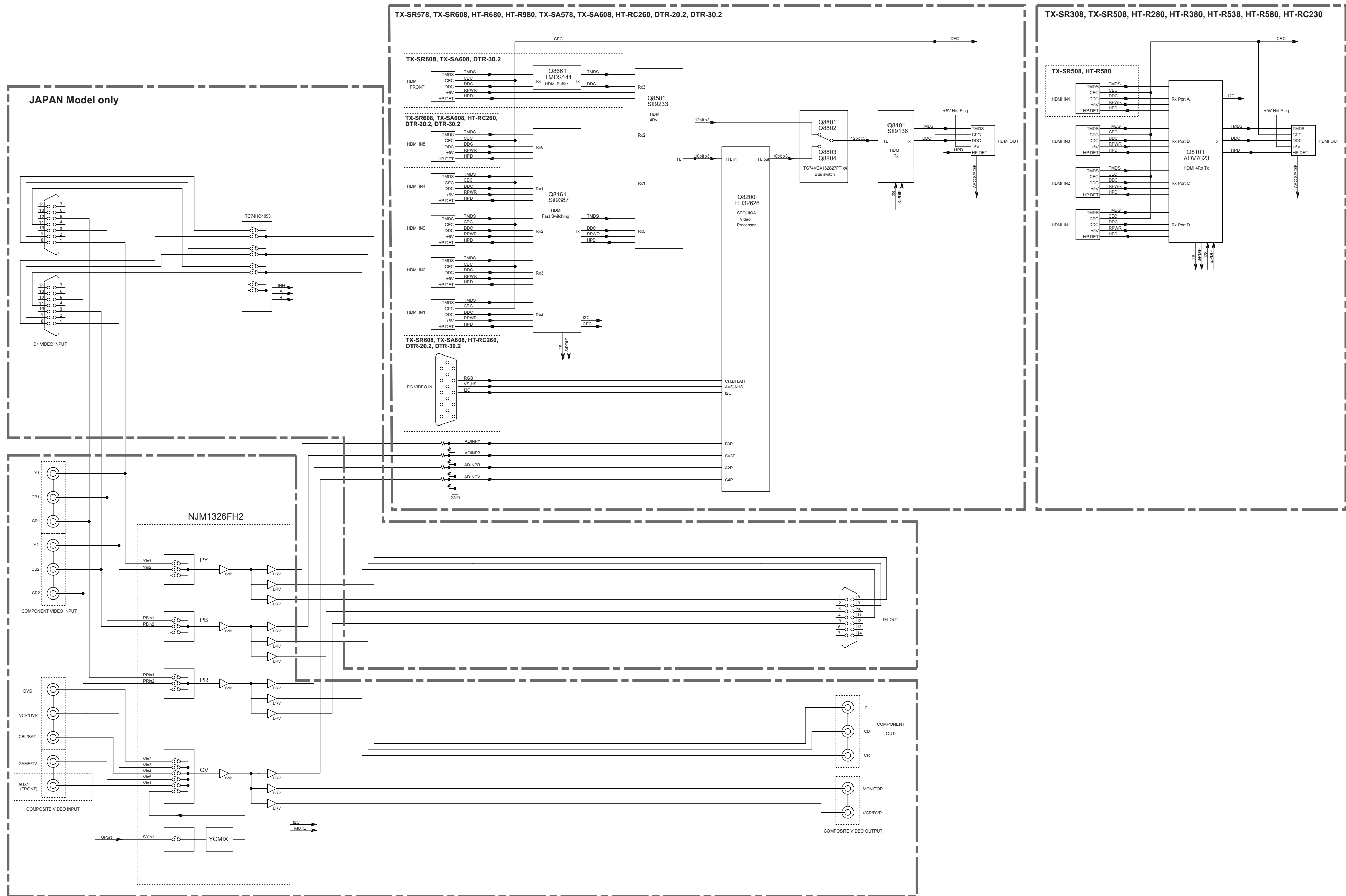

SCHEMATIC DIAGRAMS-3a

Audio INput Section

AUDIO ANALOG SIGNAL(TV/CD)

FRONT L

FRONT R

U0010 AMP (IC), ASP PC BOARD BAAF-0341

FROM SD-6 K-8 BADG-0364 (MPU SECTION) TO SD-9 A-3 BAETC-0365 (U-PORT SECTION) FROM SD-6 K-7 BADG-0364 (MPU SECTION) FROM SD-6 K-6 BADG-0364 FROM SD-6 K-6 BADG-0364 TO SD-4a K-5 BAAF-0341 (MAIN AMP) TO SD-7 K-6 BAVD-0375 (VIDEO SECCION)

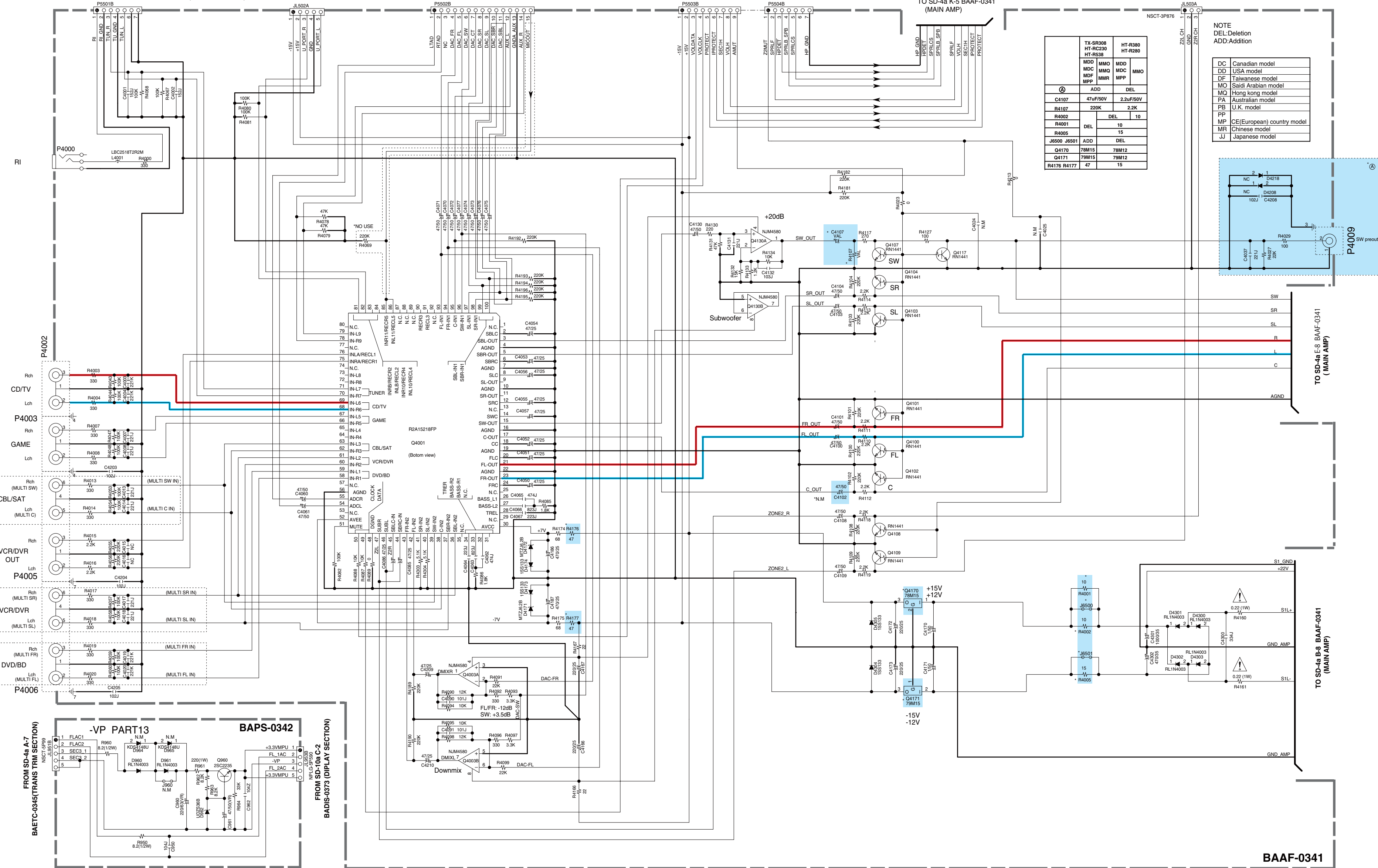
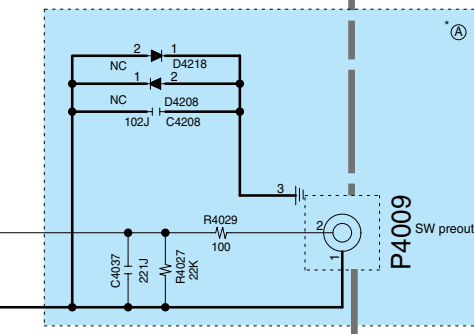

Table with 2 columns: TX-SR308 HT-R280 and HT-R380 HT-R280. Rows include MDD, MDC, MDF, MPP, ADD, DEL, and various component values.

NOTE table with columns: DEL:Deletion, ADD:Addition. Rows include DC, DD, DF, MO, MI, PA, PB, PP, MP, MF, LJ.



TO SD-4a E-8 BAAF-0341 (MAIN AMP)

TO SD-4a E-8 BAAF-0341 (MAIN AMP)

U0011 -VP PC BOARD BAPS-0342

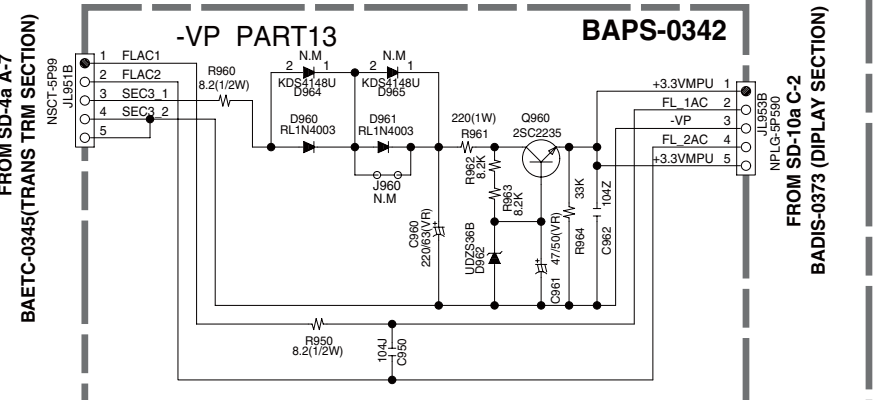

BAAF-0341

SCHEMATIC DIAGRAMS-4a

AMP(Power) Section

AUDIO ANALOG SIGNAL
FRONT L
FRONT R

BAAF-0341

U0010 AMP (IC), ASP PC BOARD BAAF-0341

THE COMPONENTS IDENTIFIED BY MARK ARE CRITICAL FOR SAFETY.
REPLACE ONLY WITH PART NUMBER SPECIFIED.
VOLTAGE(MEASURED WITH VOLTMETER) IS DC VOLTAGE
(NO INPUT SIGNAL IN HT-R340MPP)
ELECTROLYTIC CAPACITORS ARE IN uF IN uF/WV.
EX: 1000µF 300V3P 301 300V 333 0.050µF
CIRCUIT IS SUBJECT TO CHANGE FOR IMPROVEMENT.
ALL CAPACITORS ARE IN nF/50WV UNLESS OTHERWISE NOTED.

CAUTION
FOR CONTINUED PROTECTION AGAINST FIRE HAZARD, REPLACE ONLY WITH SAME TYPE AND RATING INDICATED.
ATTENTION
REPLACE ONLY WITH SAME TYPE AND RATING INDICATED.
THE SYMBOL LOCATED NEAR THE FUSE INDICATOR THAT THE FUSE USED IS IN OPERATION. THE FUSE INDICATOR WILL BE OPENED BY THE FUSE BLOWING. REFER TO THE MARKING ADJACENT TO THE SYMBOL.
CE SYMBOL INDICATES THAT THE FUSE IS IN USE. ALL FUSES FROM THE PRODUCTION PERIODS MUST BE IDENTIFIED BY THE FUSE SYMBOL. REFER TO THE MARKING ADJACENT TO THE SYMBOL.

NOTE
DEL: Deletion
ADD: Addition

Table with 2 columns: Model (e.g., DC, DD, DF) and Description (e.g., Canadian model, USA model, Taiwanese model).

Table with 3 columns: Part Number (e.g., TX-SR308, HT-R380), Model (e.g., MPP, MDC), and Description (e.g., DEL, ADD).

Table with 3 columns: Part Number (e.g., Q6002, J6477), Model (e.g., ADD, DEL), and Description (e.g., DEL, ADD).

Table with 3 columns: Part Number (e.g., C6901, C6902), Model (e.g., 8200u, 56V), and Description (e.g., 8200u, 56V).

Table with 3 columns: Part Number (e.g., F6901, F6902), Model (e.g., 8A, 125V), and Description (e.g., 8A, 125V).

Table with 3 columns: Part Number (e.g., C6080, C6081), Model (e.g., 102J, 472J), and Description (e.g., 102J, 472J).

Table with 3 columns: Part Number (e.g., R6316, J6455), Model (e.g., DEL, ADD), and Description (e.g., DEL, ADD).

Table with 2 columns: PIN NO. and Q6001/Q6002 Terminal Voltage (e.g., 1: +49V, 2: -49V).

(1)N/A for TX-SR308 (Q6002)

STK-443-530-E: TX-SR308, HT-R380, HT-R538

STK-443-530-E: HT-R380
STK-443-530-E: TX-SR308/HT-R538

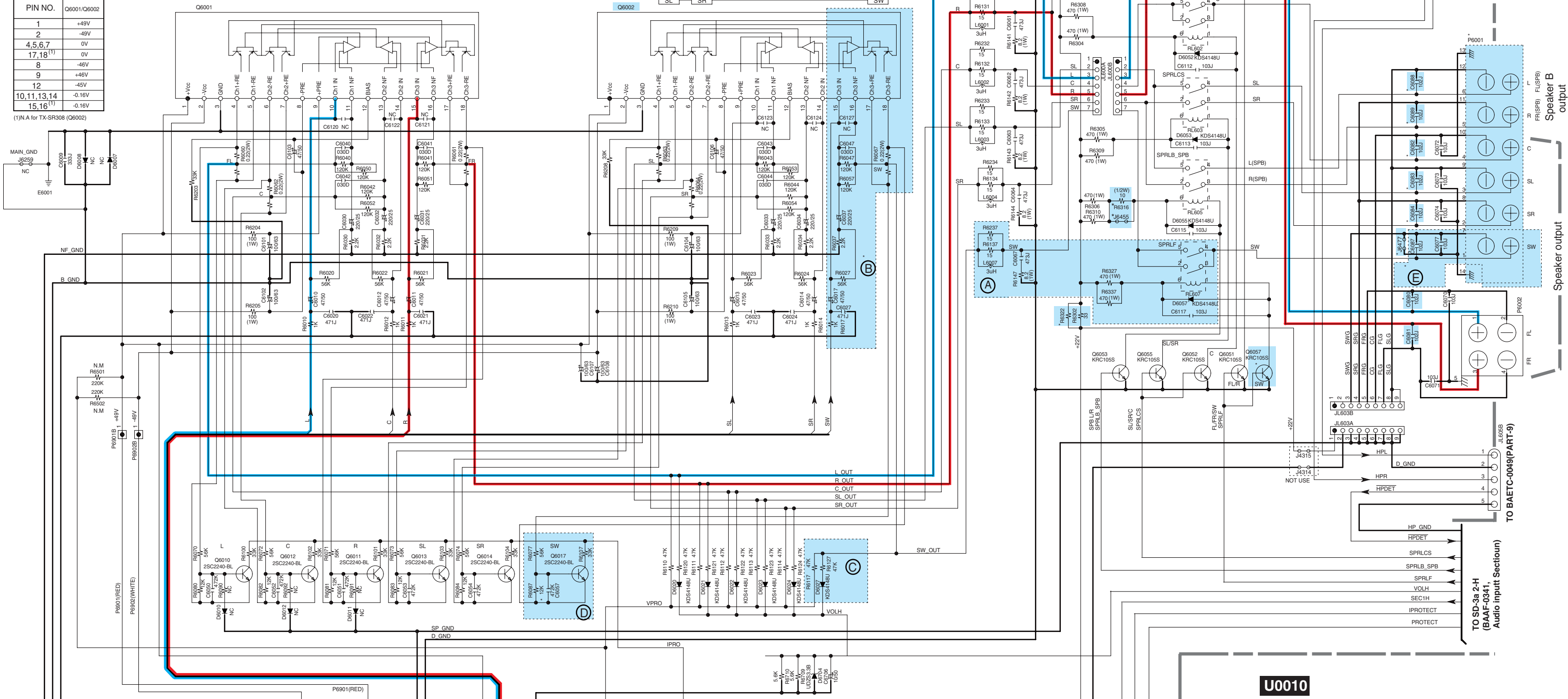

U0010
THERMAL SENSER PC BOARD
BAETC-0343

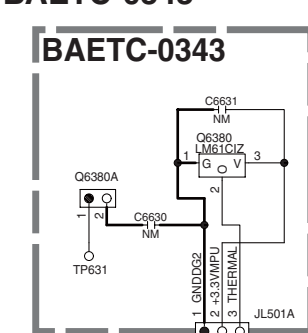

BAETC-0345

U0010
TRANS TRM PC BOARD
BAETC-0345

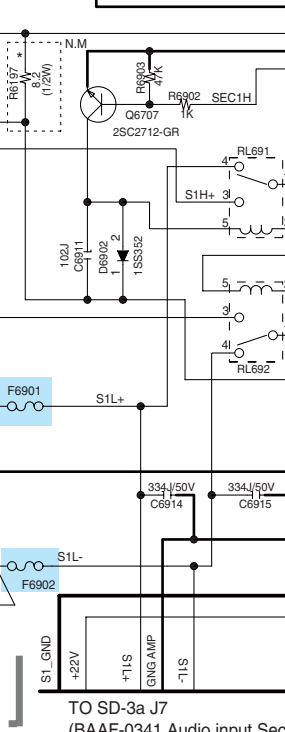

TO SD-3a J4
(BAAF-0341, Audio input Section)

TO SD-3a 2-H
(BAAF-0341, Audio input Section)

TO SD-9 K4
(BADG-0364 MPU Section)

Speaker B output

Speaker output

SCHEMATIC DIAGRAMS-6
MPU/ DIR/ DAC Section

1 **U0030**
MPU, DIR, DAC PC BOARD
BADG-0364

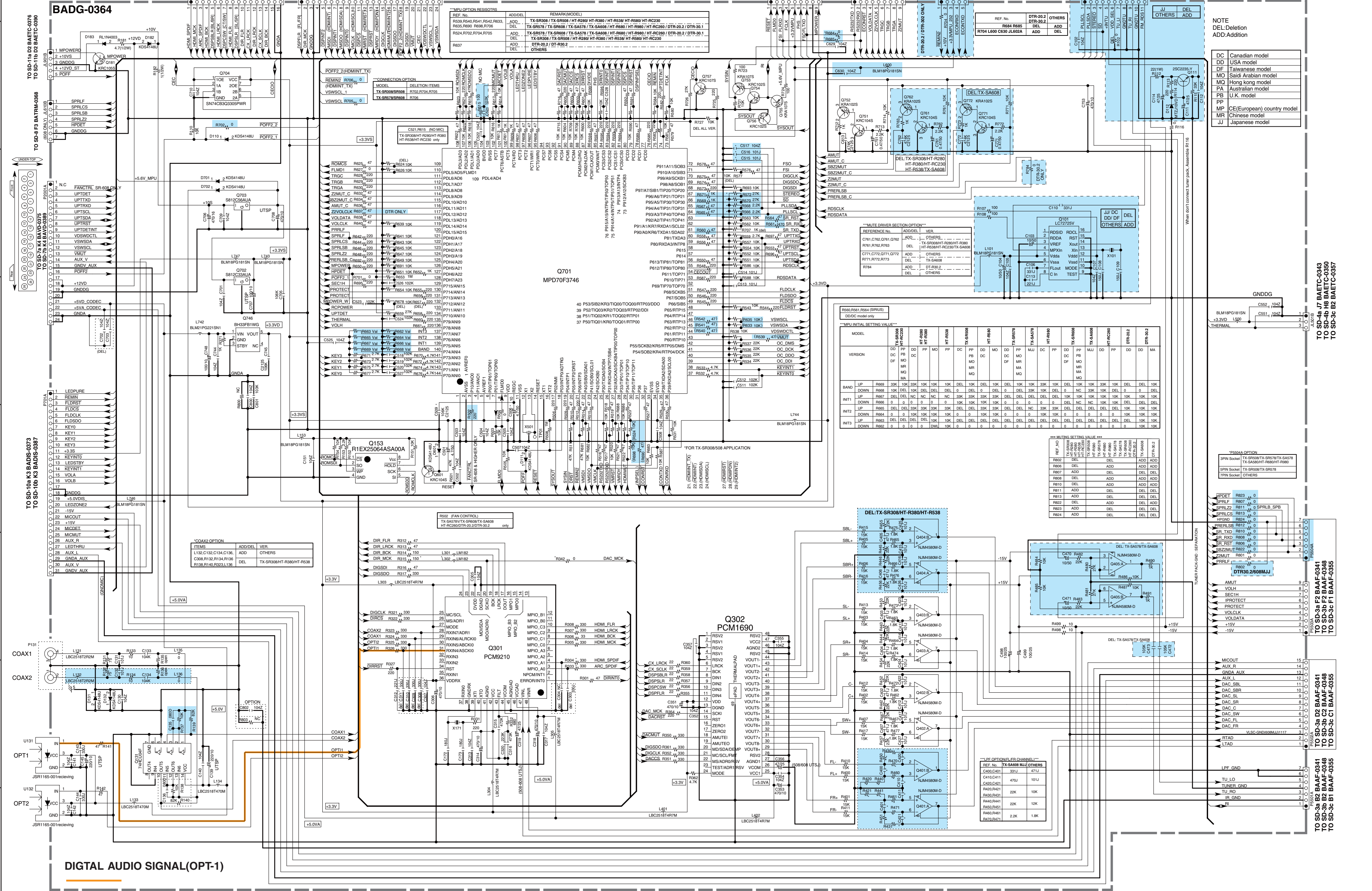

8 **DIGITAL AUDIO SIGNAL(OPT-1)**

SCHEMATIC DIAGRAMS-7

Video Section

U0042 VIDEO PC BOARD BAVD-0375
U0042 VIDEO PC BOARD BAVD-0389 (DTR-20.2/ 30.2 Only)

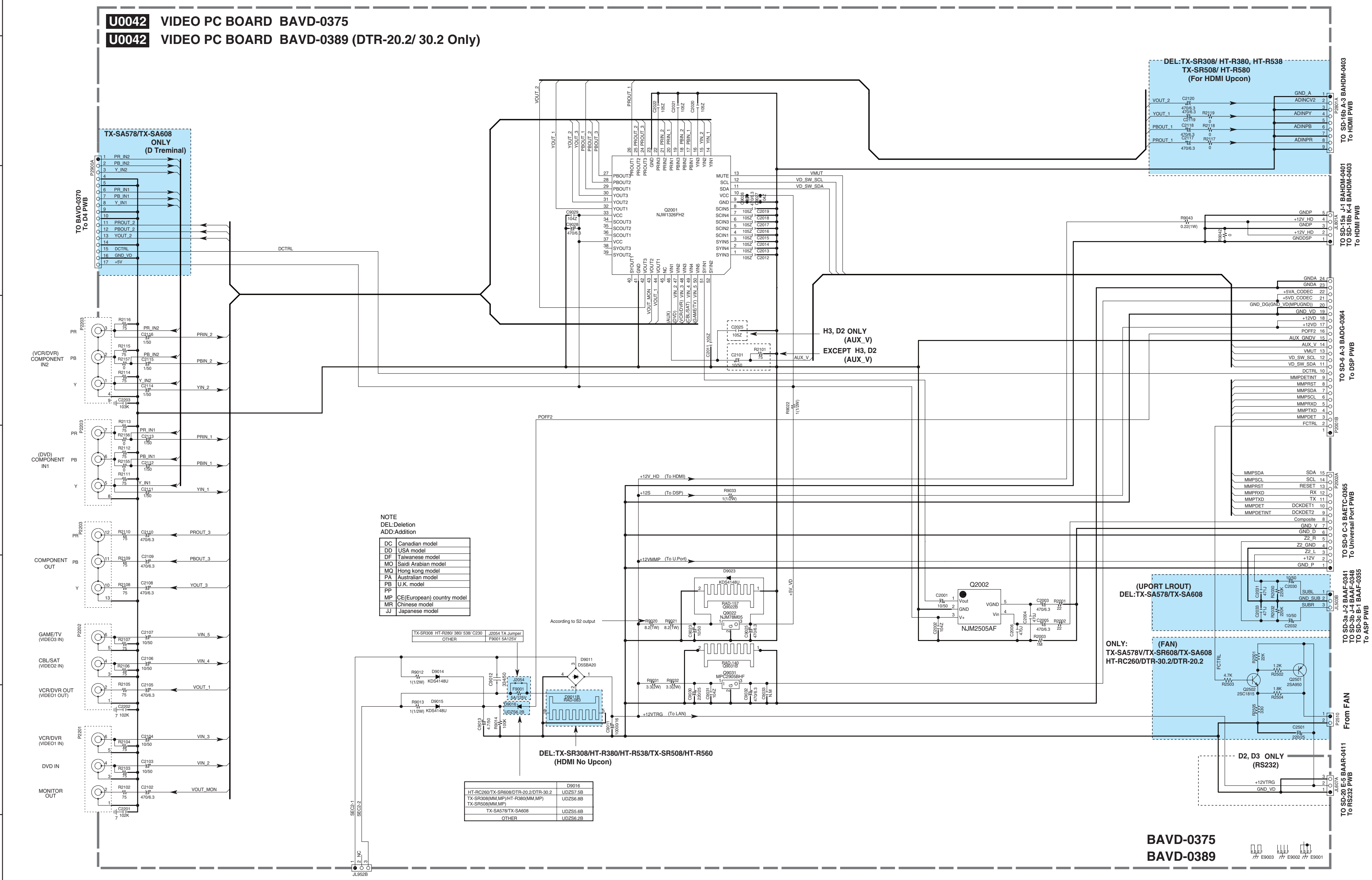

NOTE
 DEL: Deletion
 ADD: Addition

DC	Canadian model
DD	USA model
DF	Taiwanese model
MO	Saudi Arabian model
MO	Hong kong model
PA	Australian model
PB	U.K. model
PP	
MP	CE (European) country model
MR	Chinese model
JJ	Japanese model

TX-SR308/HT-R280/380/C230	J2054 TA Jumper
OTHER	F9001 SA125V

HT-RC260/TX-SR608/DTR-20.2/DTR-30.2	D9016
TX-SR308/MM-MP/HT-R380/MM-MP	UDZ57.5B
TX-SR508/MM-MP	UDZ56.8B
TX-SA578/TX-SA608	UDZ55.6B
OTHER	UDZ56.2B

TO SD-4a B-8 BAPS-0342
 TO SD-3b J-7 BAPS-0349
 TO SD-4c B-3 BAPS-0356
 TO PTRANS FIX PWB

BAVD-0375
 BAVD-0389



TO SD-16A-A-3 BAHDM-0403
 To HDMI PWB

TO SD-15a J-1 BAHDM-0401
 TO SD-18b K-4 BAHDM-0403
 To HDMI PWB

TO SD-4-A-3 BADG-0364
 To DSP PWB

TO SD-9-C-3 BAETC-0365
 To Universal Port PWB

TO SD-3b J-4 BAAF-0348
 TO SD-3c E-1 BAAF-0355
 To ASP PWB

From FAN

TO SD-20 E-5 BAAR-0411
 To RS232 PWB

A

B

C

D

E

SCHEMATIC DIAGRAMS-9

U. Port Unit Section

1

2

3

4

U0031 U. PORT PC BOARD BAETC-0365

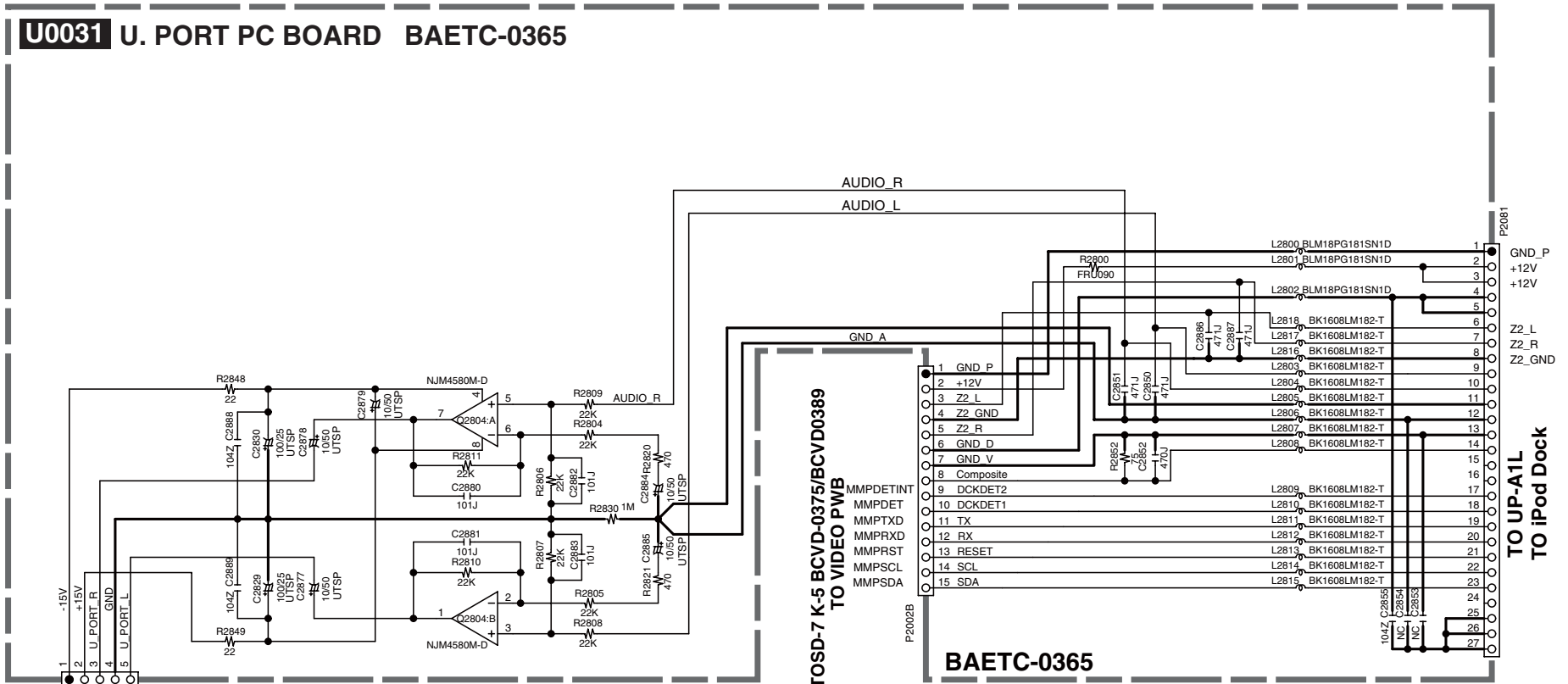

- TO SD-3a C-2 BAAF-0341
- TO SD-3b C-2 BCAF-0348
- TO SD-3c C-2 BCAF-0355
- TO Audio Input PWB

BAETC-0365

SCHEMATIC DIAGRAMS-10a

Display Section

1

U0044 HP PC BOARD BAETC-0377

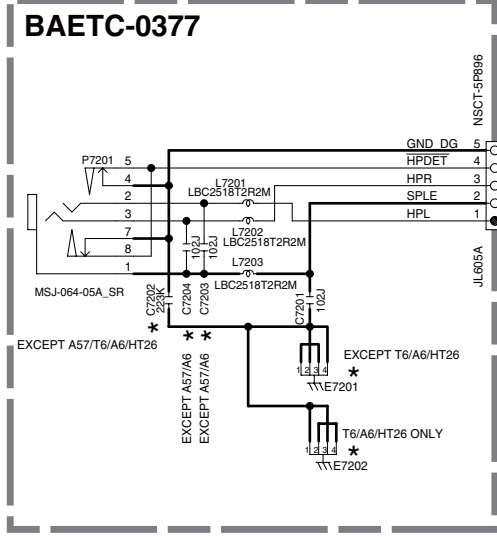

TO SD-8 B-1 BAFTRM-0368
FROM SP-OUT PWB
TO SD-4a K-4 BAAF-0341
FROM AMP PWB

TO -VP PWB

TO SD-3a C-7 BAPS-0342
TO SD-3b C-7 BAPS-0349
TO SD-3c C-7 BAPS-0356

NOTE
DEL: Deletion
ADD: Addition

DC	Canadian model
DD	USA model
DF	Taiwanese model
MO	Saudi Arabian model
MQ	Hong kong model
PA	Australian model
PB	
MB	U.K. model
PP	
MP	CE(European) country model
MR	Chinese model
JJ	Japanese model

U0040 DISPLAY PC BOARD BADIS-0373

BADIS-0373

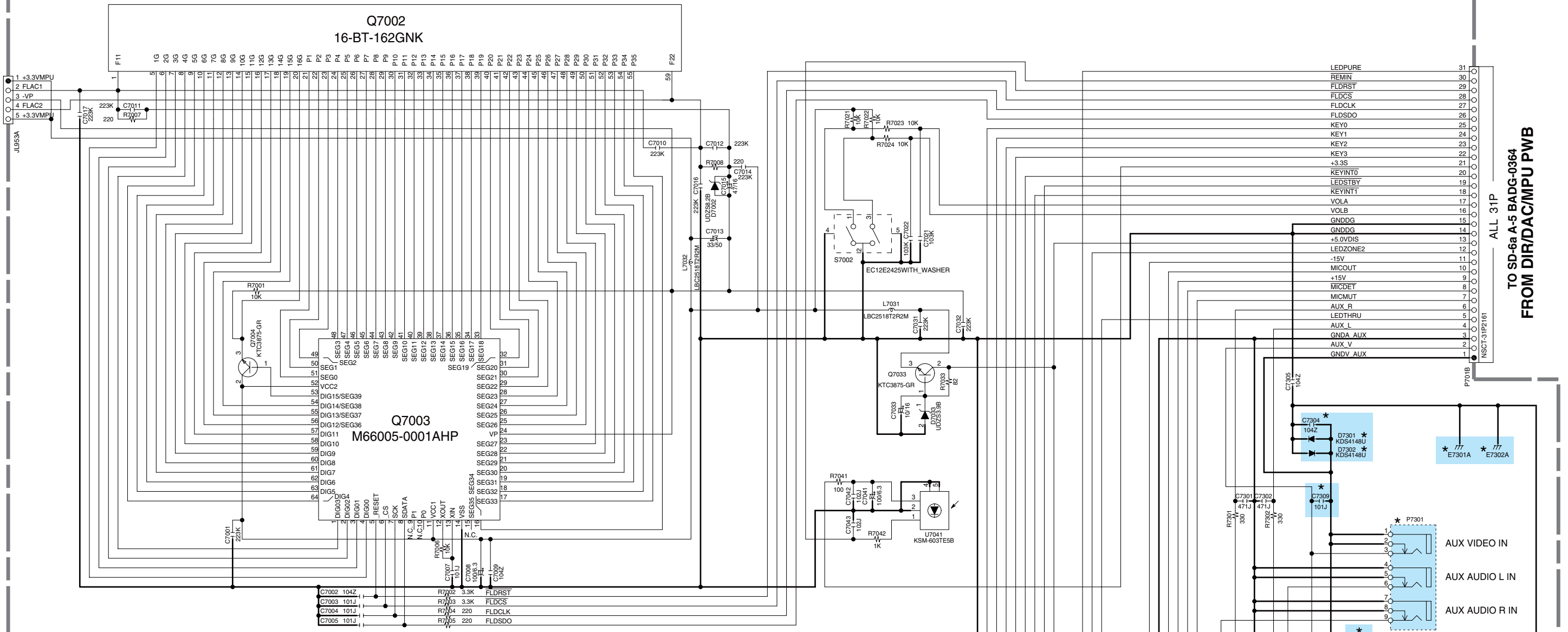

TO SD-6a A-5 BADG-0364
FROM DIR/DAC/MPU PWB

U0041 KEY SWITCH PC BOARD BADIS-0374

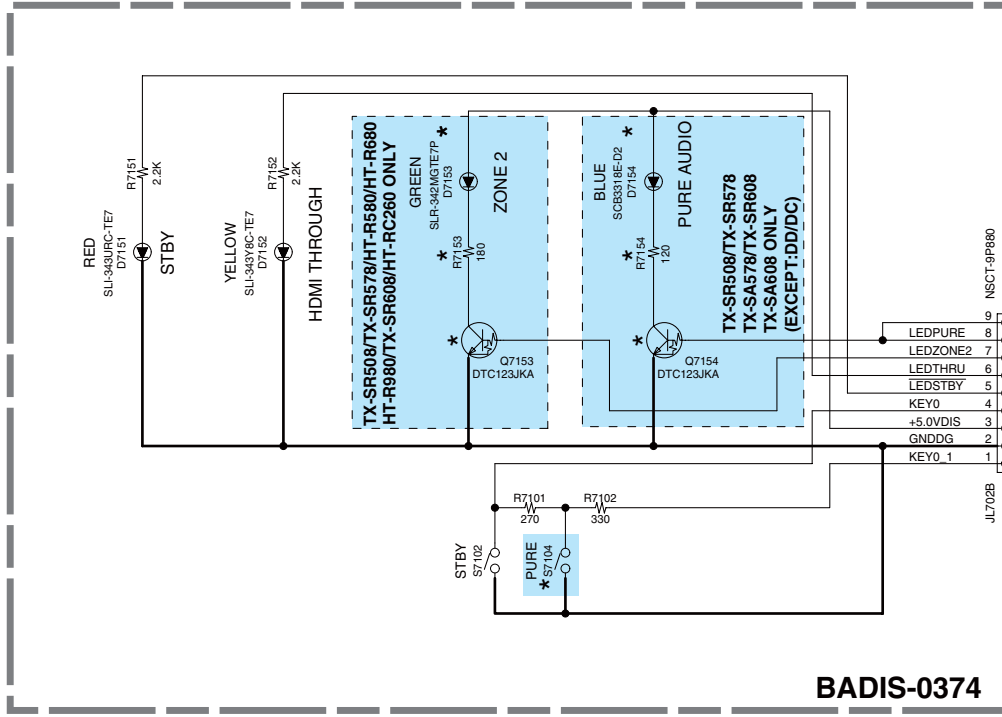

BADIS-0374

CODE	S7104
HT-R980	THX
TX-SR308/HT-R280/HT-R380/HT-R538 HT-R580/HT-R680/C230	MUSIC OPTIMIZER
TX-SR508/HT-R578/HT-R608 (EXCEPT DC-DD)	PURE AUDIO
TX-SA578/HT-SA608	DEL
TX-SR608/HT-RC260 (DC,DD)	

TX-SR308 HT-R280/380/538/C230	S7106	S7108
TX-SR508/578/608 HT-R580/680/980/C260	SP-A	SP-B
TX-SA578/578V/608	ZONE-2	ZONE-2
	RHHD	MUSIC OPTIMIZER

DEL: TX-SR608/TX-SA608/HT-RC260

ONLY: TX-SR608/TX-SA608/HT-RC260

TX-SA578/578V TX-SA608	S7134	S7132
Others	CINEMA FILTER Re-EO	LATE NIGHT LATE NIGHT
	MEMORY	TUNING

CODE	R7106	R7107	R7108	R7109	R7110	R7130
DEL-HT-RC260	270	330	470	560	820	0
ADD-HT-RC260	0	270	330	470	560	820

TX-SR608 TX-SA608 HT-RC260	TX-SR308 HT-R380 HT-R538	OTHERS
C7304 C7306 C7309 D7301 D7302	ADD	ADD
E7301A	DEL	ADD
E7301	ADD	DEL
P7312 R7305	ADD	DEL
P7311 R7304	DEL	ADD
P7302	ADD	DEL
P7301	DEL	ADD

8

A B C D E

SCHEMATIC DIAGRAMS-11



Power Supply Sectio

U0043 POWER SUPPLY PC BOARD BAETC-0376/ BAETC-0390

<NOTE>

DC	Canadian model
DD	USA model
DF	Taiwanese model
MO	Saudi Arabian model
MQ	Hong kong model
PA	Australian model
PB	
MB	U.K. model
PP	
MP	CE(European) country model
MR	Chinese model
JJ	Japanese model

- 印は火災、感電の危険に關する部品の為、必ず指定部品を使用の事。
- 電圧表示は無信号時に測定した直流電圧を示す。
(単位V、入力抵抗100KΩ/V以上の電圧計)
- 記入なきコンデンサの単位はμF/VVである。
例 030→3pF 330→33pF 331→330pF 333→0.033μF
- 本配線図は基本配線図につき性能改善等により予告なく変更する事がある。

- * THE COMPONENTS IDENTIFIED BY MARK  ARE CRITICAL FOR SAFETY. REPLACE ONLY WITH PART NUMBER SPECIFIED.
- * VOLTAGE (MEASURED WITH VOLT METER) IS DC VOLTAGE. (NO INPUT SIGNAL)
- * ELECTROLYTIC CAPACITORS () ARE IN μF/VV.
- * ALL CAPACITORS ARE IN pF/50V UNLESS OTHERWISE NOTED.
- E X) 030→3pF 330→33pF 331→330pF 333→0.033μF
- * CIRCUIT IS SUBJECT TO CHANGE FOR IMPROVEMENT.

CAUTION



FOR CONTINUED PROTECTION AGAINST FIRE HAZARD, REPLACE ONLY WITH FUSE OF SAME TYPE AND RATING INDICATED.

ATTENTION



AFIN D'ASSURER UNE PROTECTION PERMANENTE CONTRE LES RISQUES D'INCENDIE, REMPLACER UNIQUEMENT PAR UN FUSIBLE DE MEME TYPE ET CALIBRATION COMME INDIQUE.



THIS SYMBOL LOCATED NEAR THE FUSE INDICATES THAT THE FUSE USED IS SLOW OPERATING TYPE FOR CONTINUED PROTECTION AGAINST FIRE HAZARD. REPLACE WITH SAME TYPE FUSE. FOR FUSE RATING REFER TO THE MAKING ADJACENT TO THE SYMBOL.

3



CE SYMBOLE INDIQUE QUE LE FUSIBLE UTILISE EST A LENT, E POUR UNE PROTECTION PERMANENTE. N'UTILISER QUE DES FUSIBLES DE MEME TYPE. CE DERNIER EST INDIQUE LA QU LE PRESENT SYMBOLE EST APPOSE.

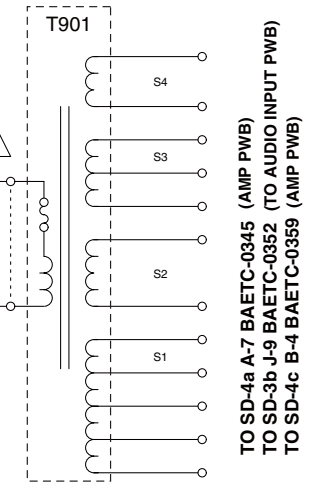
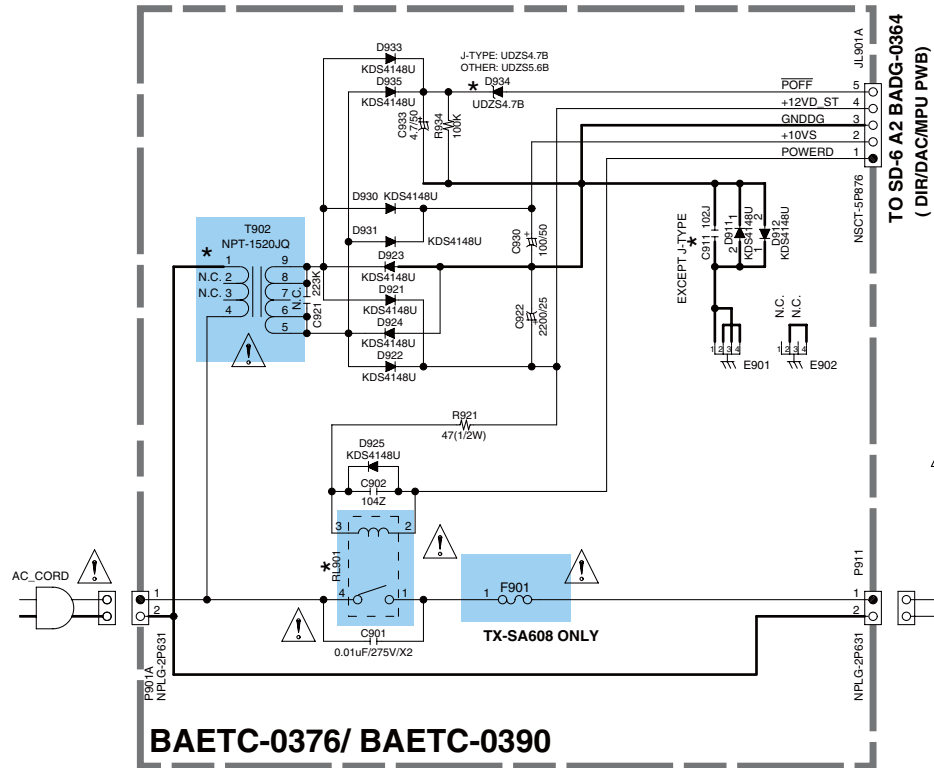

TO SD-4a A-7 BAETC-0345 (AMP PWB)
TO SD-3b J-9 BAETC-0352 (TO AUDIO INPUT PWB)
TO SD-4c B-4 BAETC-0359 (AMP PWB)

4

<T902>

TYPE	TX-SR308/HT-R380 TX-SR508/HT-R580 TX-SR578/TX-SR608 DTR-30.2	HT-R280/HT-R680 HT-R980/HT-RC230 HT-RC260/DTR20.2	HT-R538	TXSA578 TX-SA608
DC/ DD/ DF	NPT-1520JQ	NPT-1520JQ	---	---
MO/ MQ/ MR/ PA/ PP/ PB	NPT-1520GQ	---	NPT-1520GQ	---
JJ	---	---	---	NPT-1520JQ

<F901>

DC/ DD/ DF	8A 125V	8A 125V	---	---
MO/ MQ/ MR/ PA/ PP/ PB	T4A L250V	---	T4A L250V	---
JJ	---	---	---	10A 125V

<RL901>

DC/ DD/ DF	NRL-1P5A	NRL-1P5A	---	---
MO/ MQ/ MR/ PA/ PP/ PB	NRL-1P5A	---	NRL-1P5A	---
JJ	---	---	---	NRL-1P10A

<T901>

TYPE	DD/ DC/ DF	PA/ PP/ PB	MO/ MQ/ MR	JJ
TX-SR308 HT-R280 HT-R380 HT-R538 HT-RC230	NPT-1589D	NPT-1589P	NPT-1589M	---
TX-SR508 TX-SR578 TX-SA578 HT-R580 HT-R680 HT-R980	NPT-1594D	NPT-1594P	NPT-1594M	NPT-1594J
TX-SR608 HT-RC260 DTR-20.2 DTR-30.2	NPT-1592D	NPT-1592M	NPT-1592M	NPT-1592J

SCHEMATIC DIAGRAMS-15a

HDMI Section

1
2
3
4
5
6
7
8

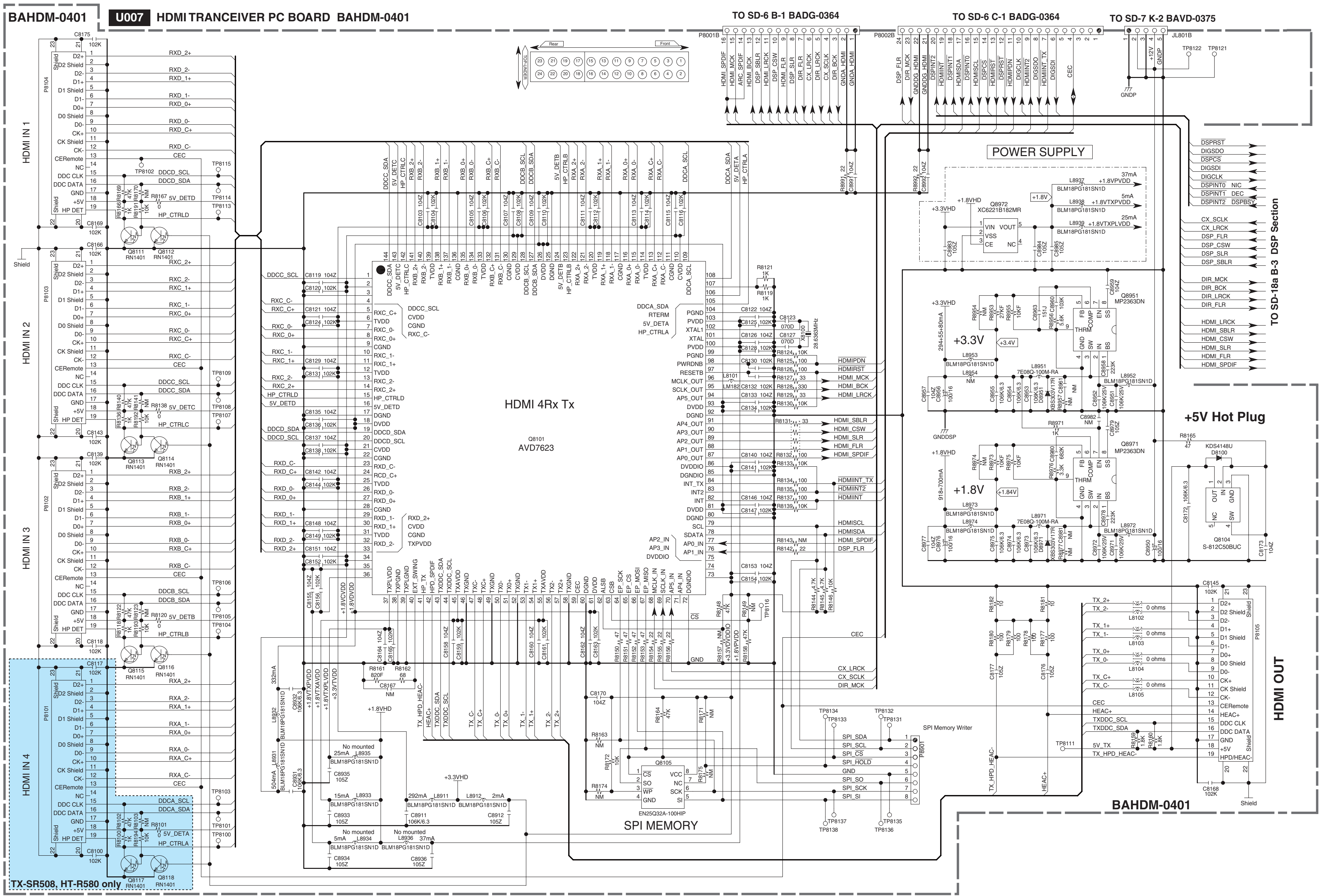

TX-SR508, HT-R580 only

SCHEMATIC DIAGRAMS-18a

DSP Section

U007 HDMI DSP (DA788) PC BOARD BAHDM-0401

BAHDM-0401

TO SD-14 J-3 BAHDM-0401 (HDMI Section)

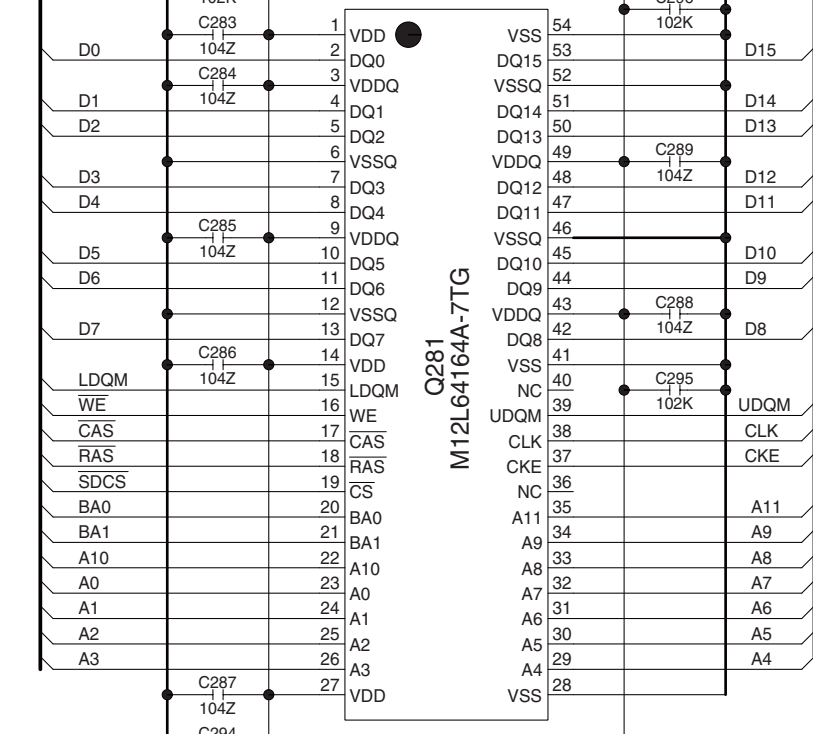
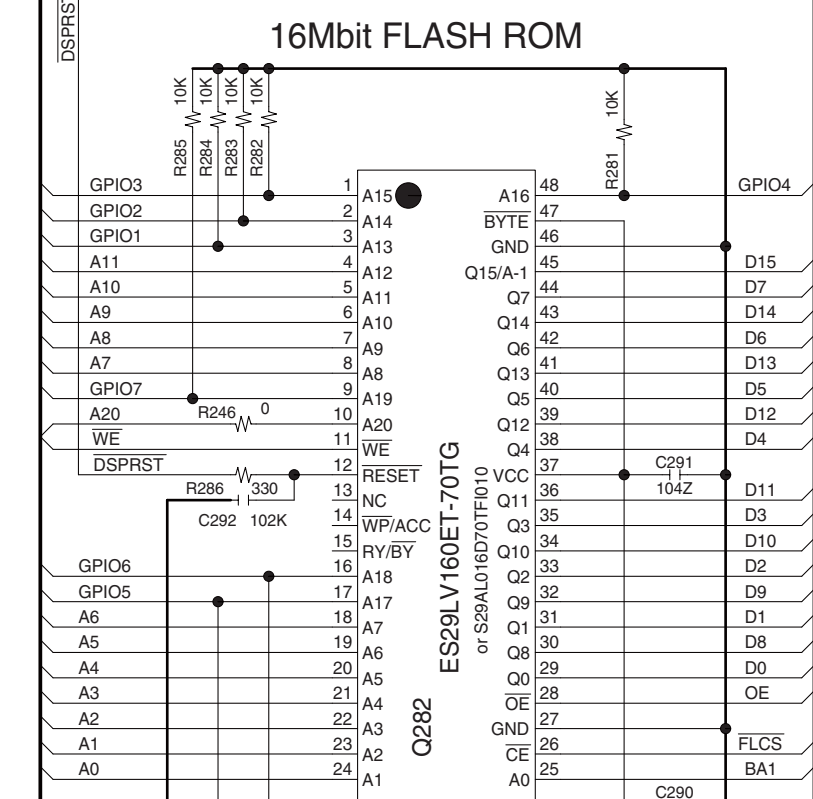
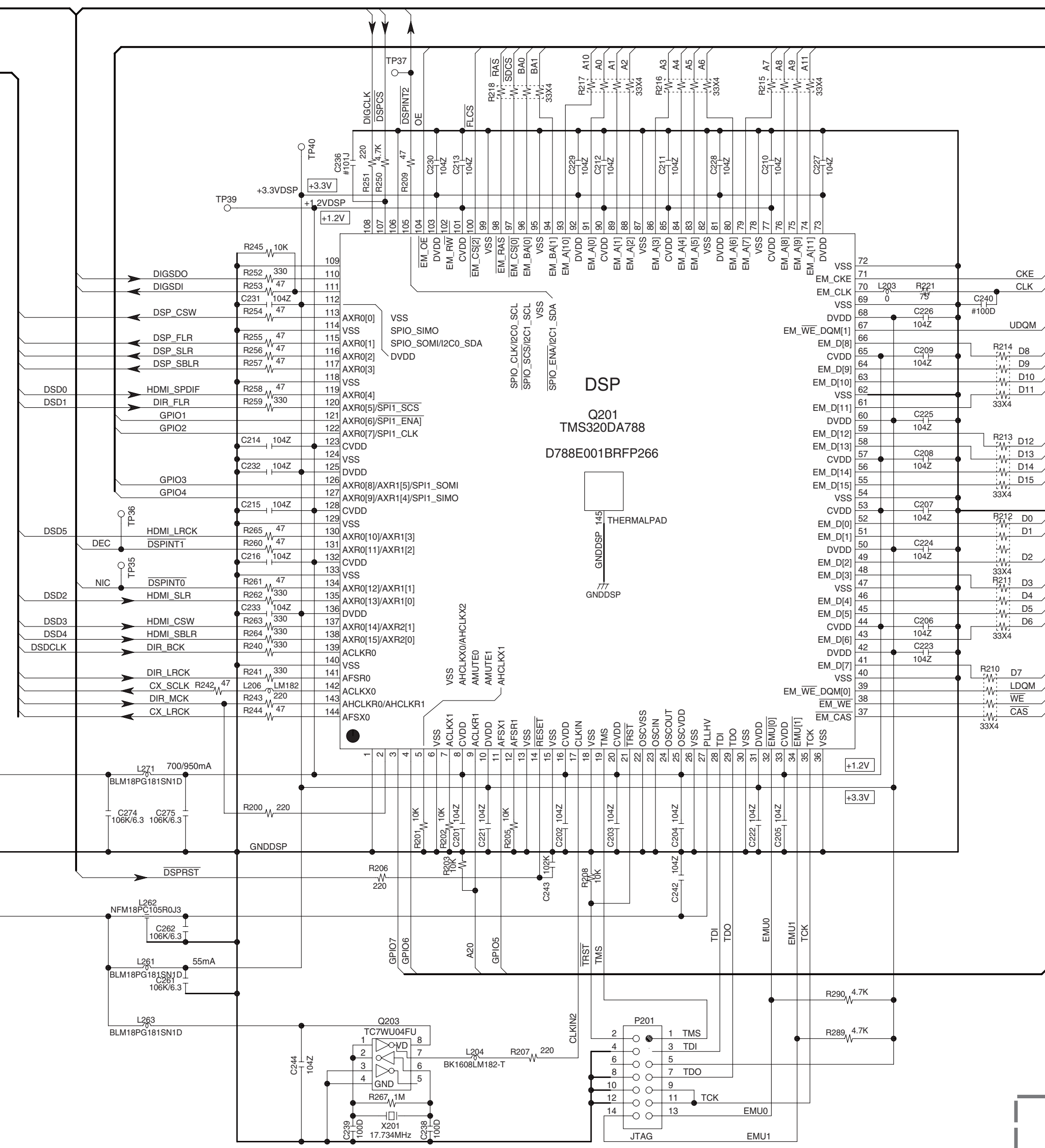
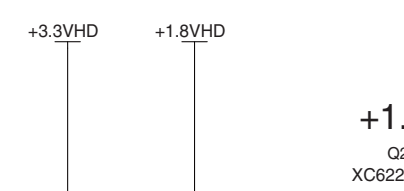
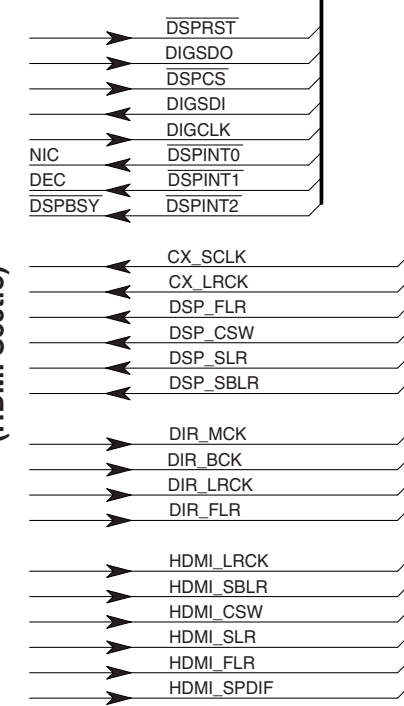

BAHDM-0401

PRINTED CIRCUIT BOARD VIEWS-1_1
AMPLIFIER SECTION

1
2
3
4
5

U0010

BAAF-0341 (AMPLIFIER PC BOARD)
A-side(Component side)

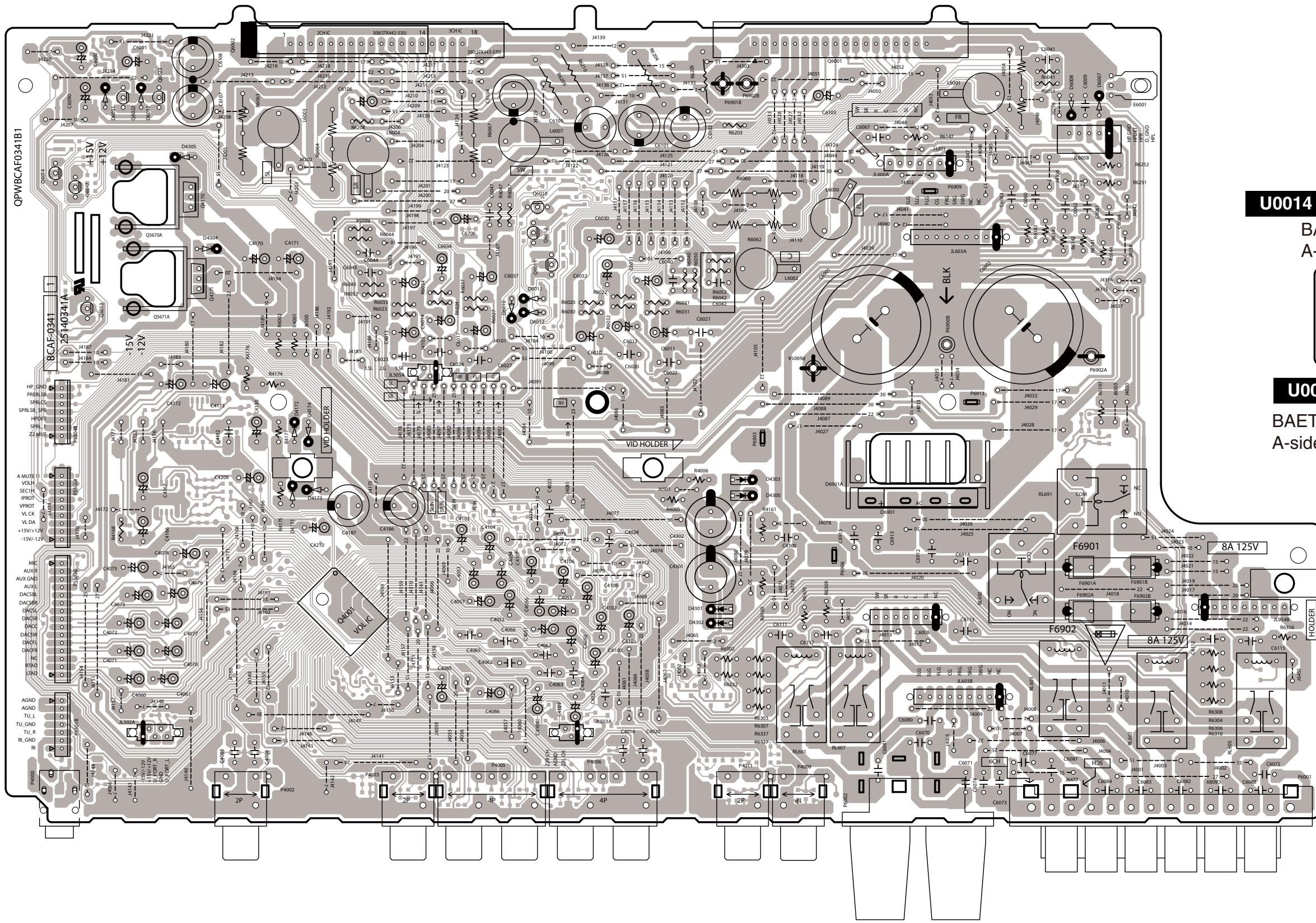

U0011

BAPS-0342 (FL TUBE -VP PC BOARD)
A-side(Component side)

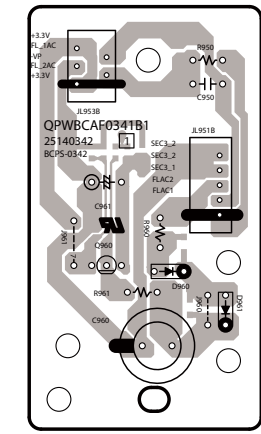

U0014

BAETC-0345 (TRANS TRM PC BOARD)
A-side(Component side)

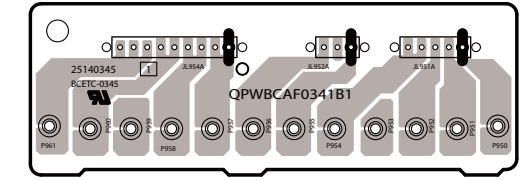

U0012

BAETC-0343 (THERMAL SEN PC BOARD)
A-side(Component side)

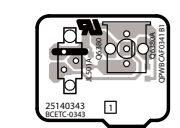

PRINTED CIRCUIT BOARD VIEWS-1_2
AMPLIFIER SECTION

1

U0011

BAPS-0342 (FL TUBE -VP PC BOARD)
B-side(Soldering side)

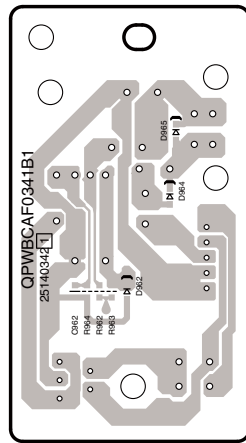

2

U0010

BAAF-0341 (AMPLIFIER PC BOARD)
B-side(Soldering side)

3

U0014

BAETC-0345 (TRANS TRM PC BOARD)
B-side(Soldering side)

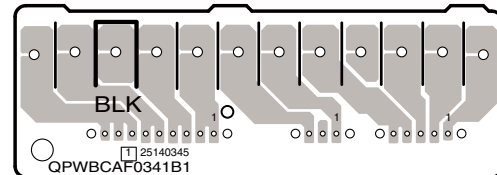

4

U0012

BAETC-0343 (THERMAL SEN PC BOARD)
B-side(Soldering side)

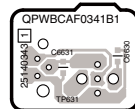

5

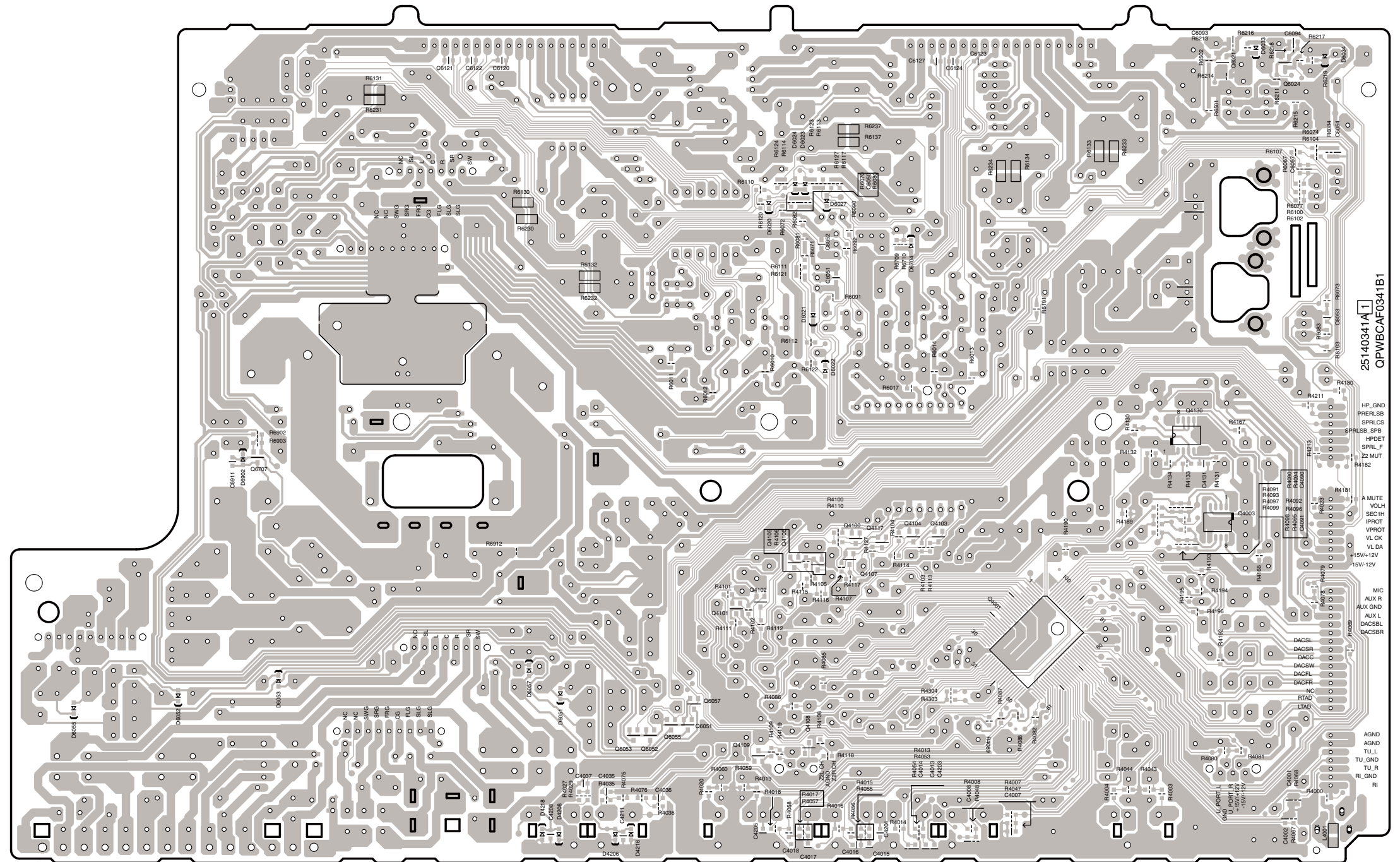

25140341A QPWBCAF0341B1
HP_GND
PRFLSB
SPRLCS
SPRLSB_SPB
HPDET
SPRL_F
I23 MUT
R4182
A MUTE
VOLH
SEC1H
IPROT
VPHOT
VL CK
VL DA
+15V+12V
-15V-12V
MIC
AUX R
AUX GND
AUX L
DACSL
DACSR
DACSW
DACFR
DACR
RTAD
LTAD
AGND
AUXND
TU_L
TU_GND
TU_R
RI_GND
RI

**PRINTED CIRCUIT BOARD VIEWS-3
DAC/ MPU SECTION**

A B C D E F G H

1

U0031
BAETC-0365 (U-PORT PC BOARD)
A-side(Component side)

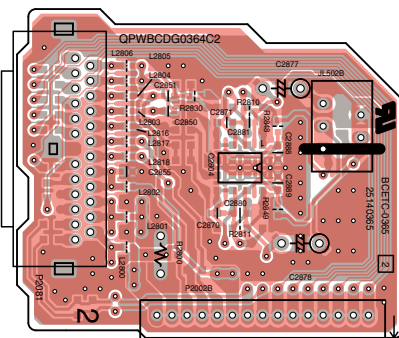

U0031
BAETC-0365 (U-PORT PC BOARD)
B-side(Soldering side)

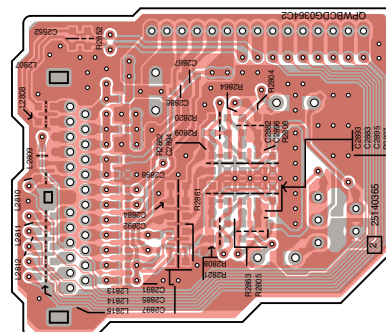

U0030 BADG-0364 (MPU/DAC PC BOARD)
A-side(Component side)

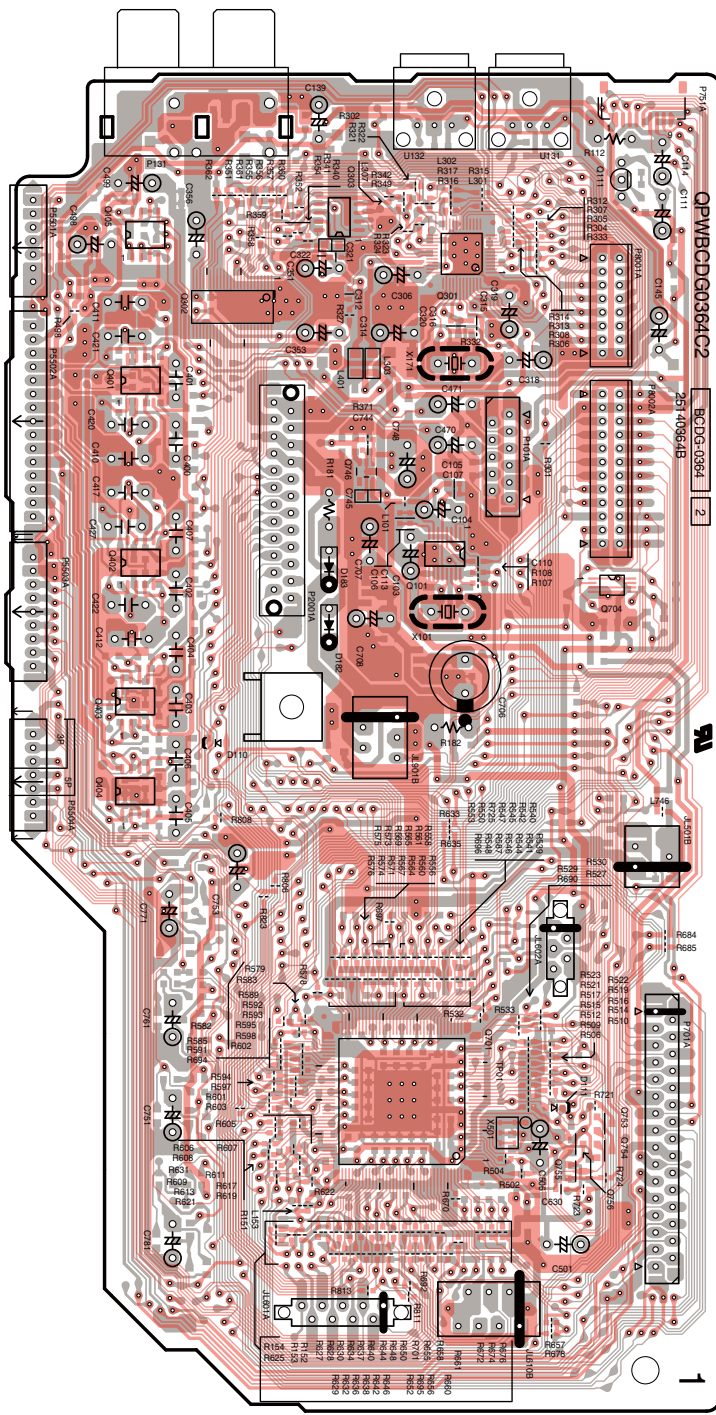

U0030 BADG-0364 (MPU/DAC PC BOARD)
B-side(Soldering side)

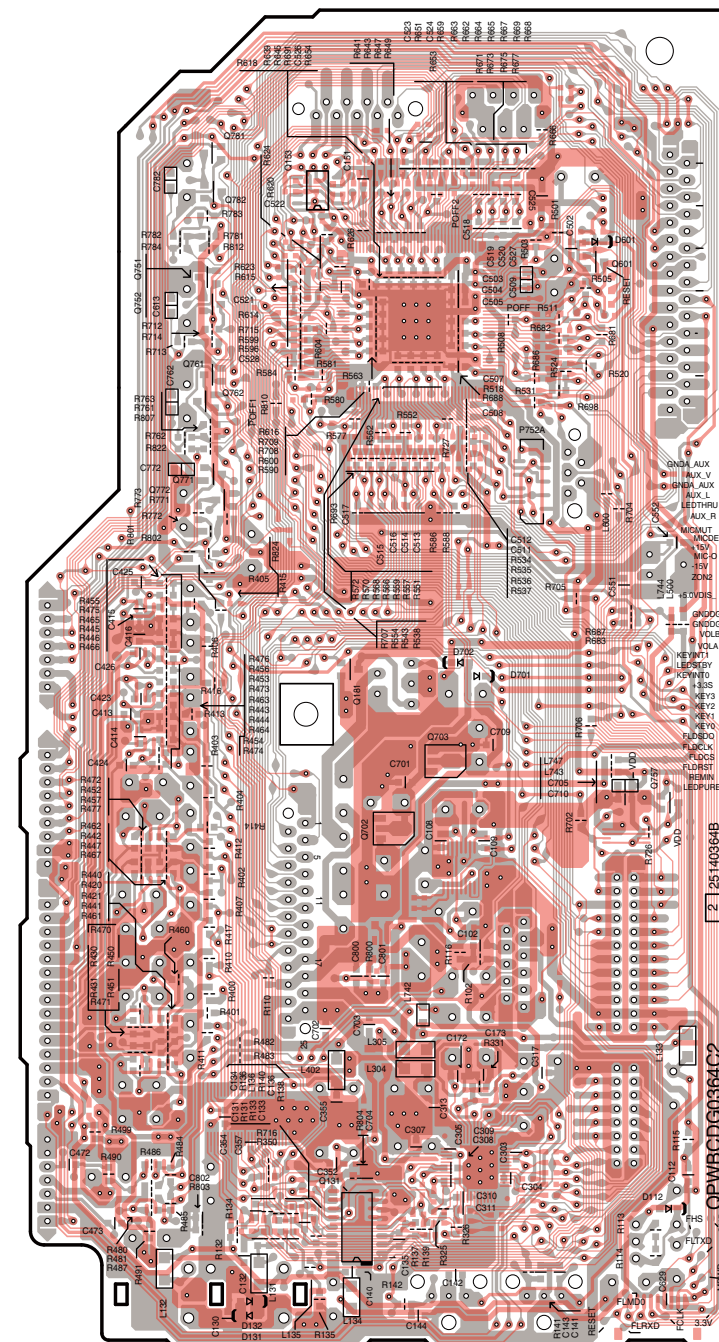

2

U0032 Japanese Model Only
BAETC-0366 (VLSC PC BOARD)
A-side(Component side)

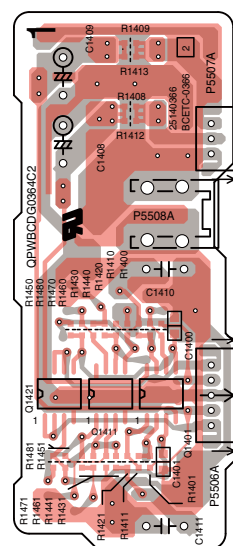

U0032 Japanese Model Only
BAETC-0366 (VLSC PC BOARD)
B-side(Soldering side)

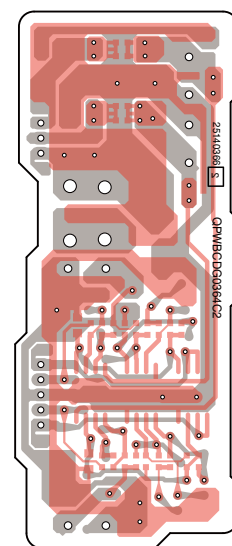

3

4

5

A B C D E F G H

**PRINTED CIRCUIT BOARD VIEW-4_1
DISPLAY SECTION**

U0040 BADIS-0373 (DISPLAY PC BOARD)
A-side(Component side)

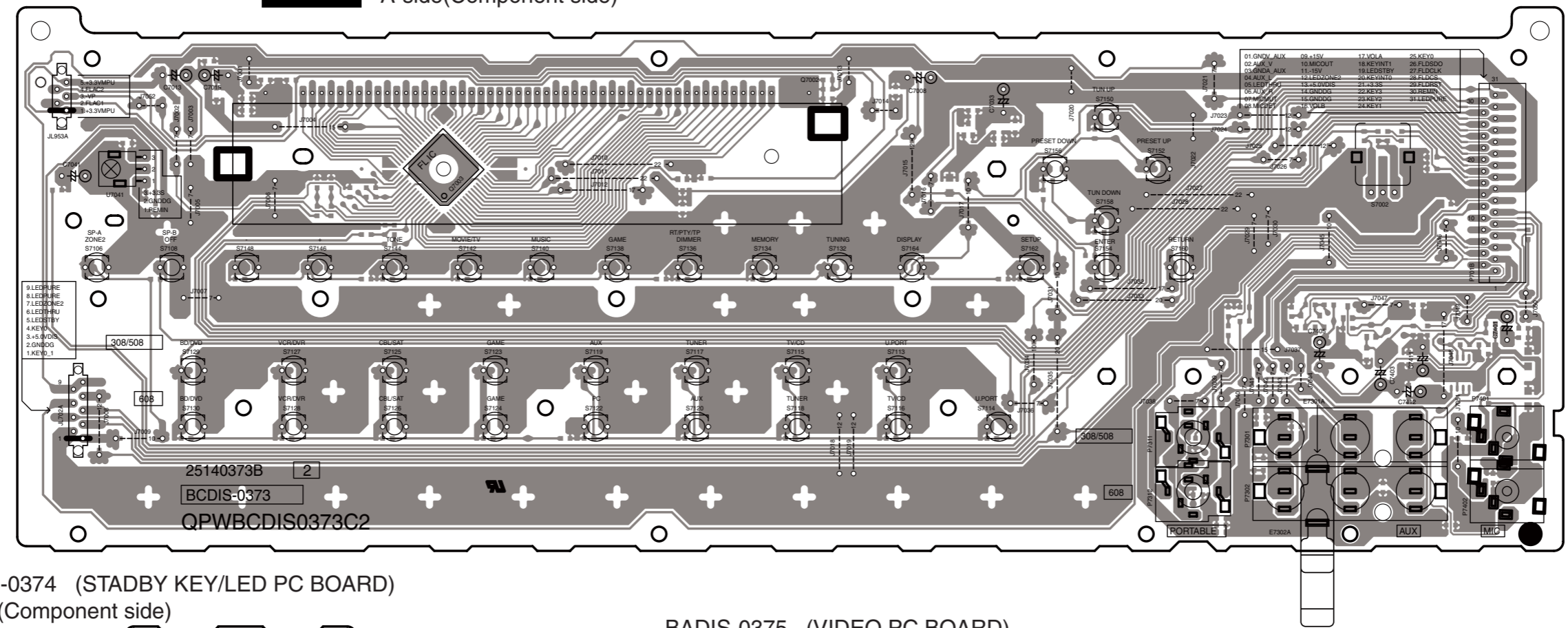

U0041 BADIS-0374 (STADBY KEY/LED PC BOARD)
A-side(Component side)

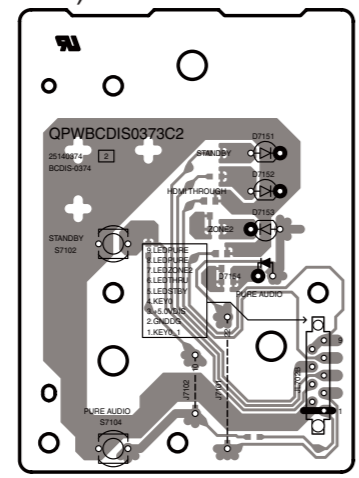

U0042 BADIS-0375 (VIDEO PC BOARD)
A-side(Component side)

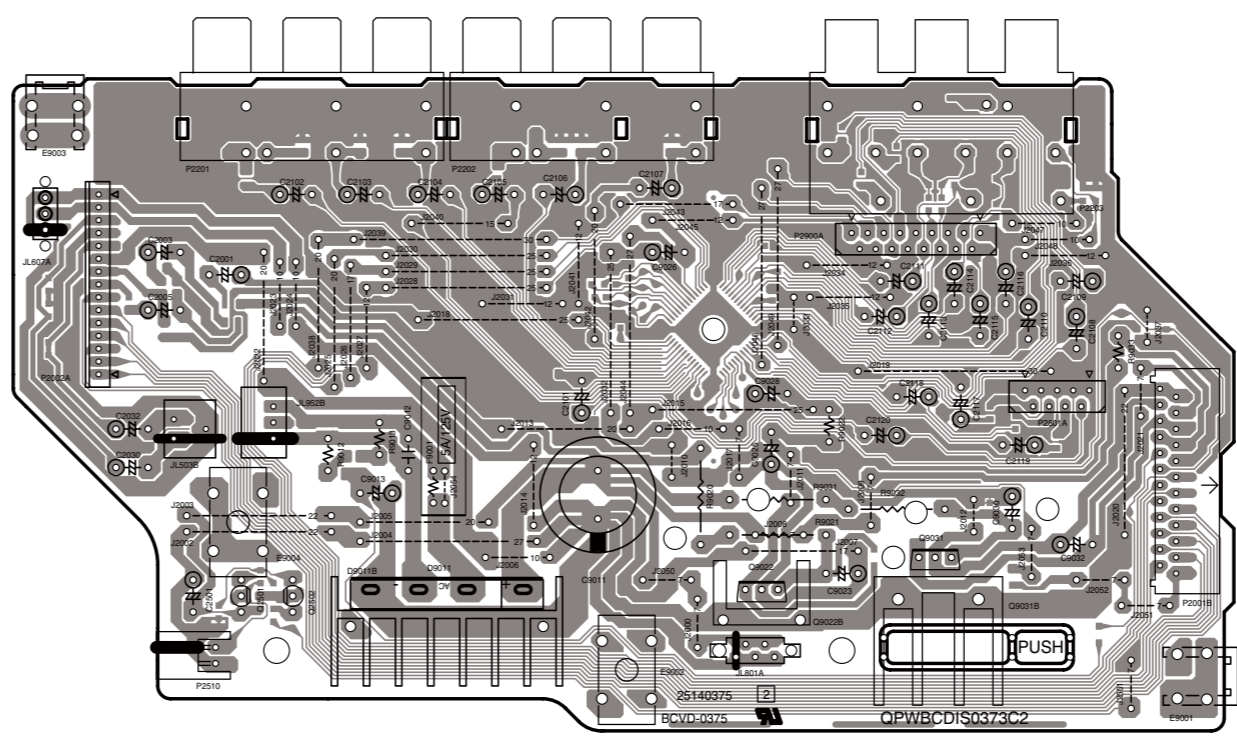

U0043 BAETC-0376 (POW SUPPLY PC BOARD)
A-side(Component side)

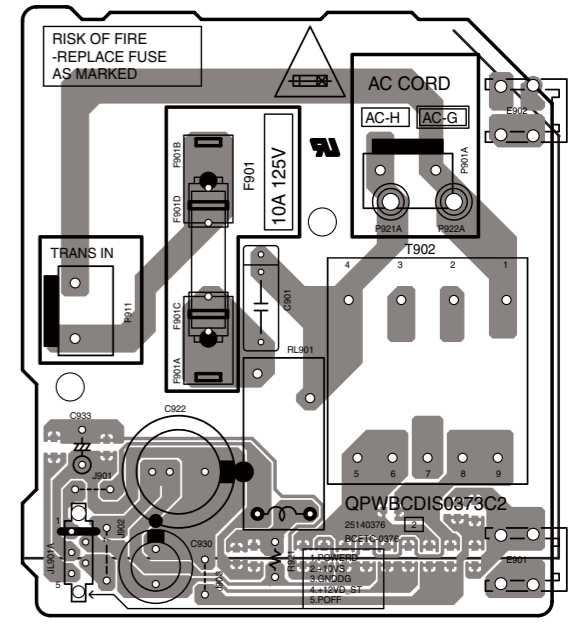

U0044 BAETC-0377 (HP JACK PC BOARD)
A-side(Component side)

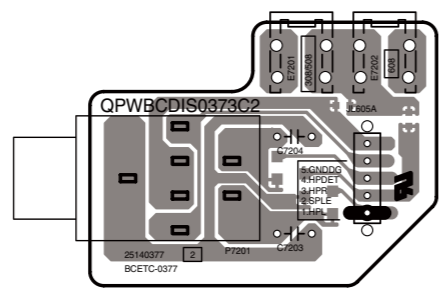

1

2

3

4

5

A B C D E F G H

PRINTED CIRCUIT BOARD VIEWS-4_2
DISPLAY SECTION

U0040 BADIS-0373 (DISPLAY PC BOARD)
B-side(Soldering side)

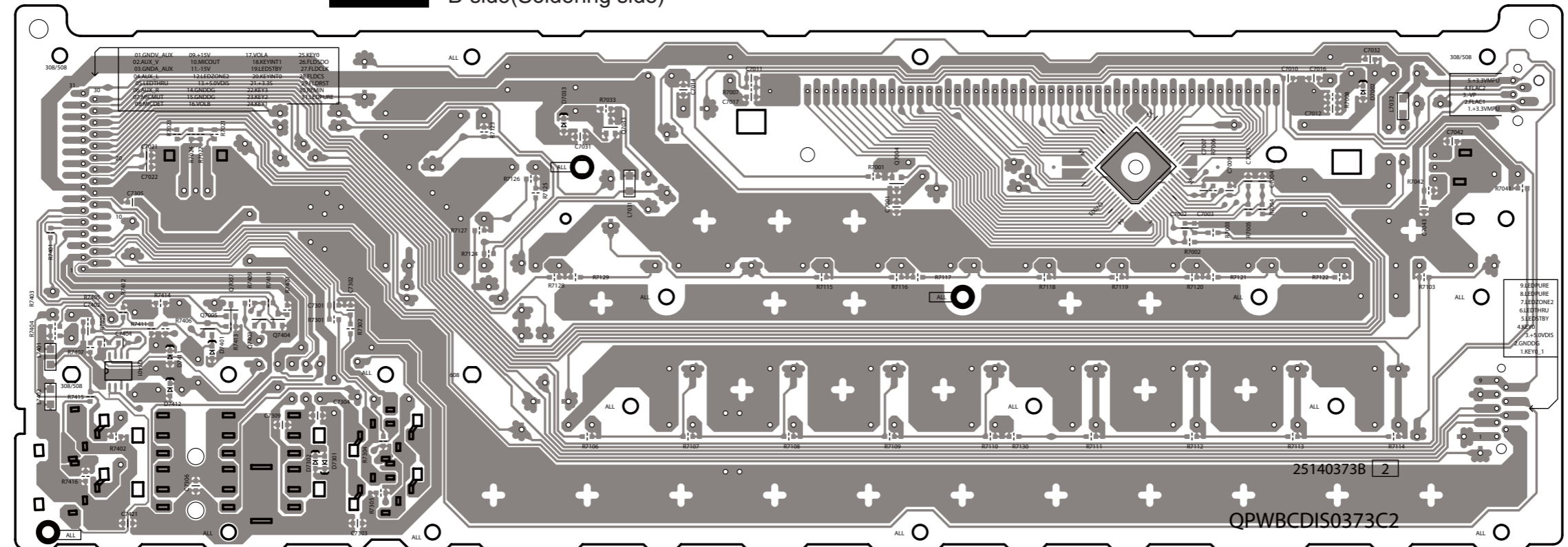

U0042 BADIS-0375 (VIDEO PC BOARD)
B-side(Soldering side)

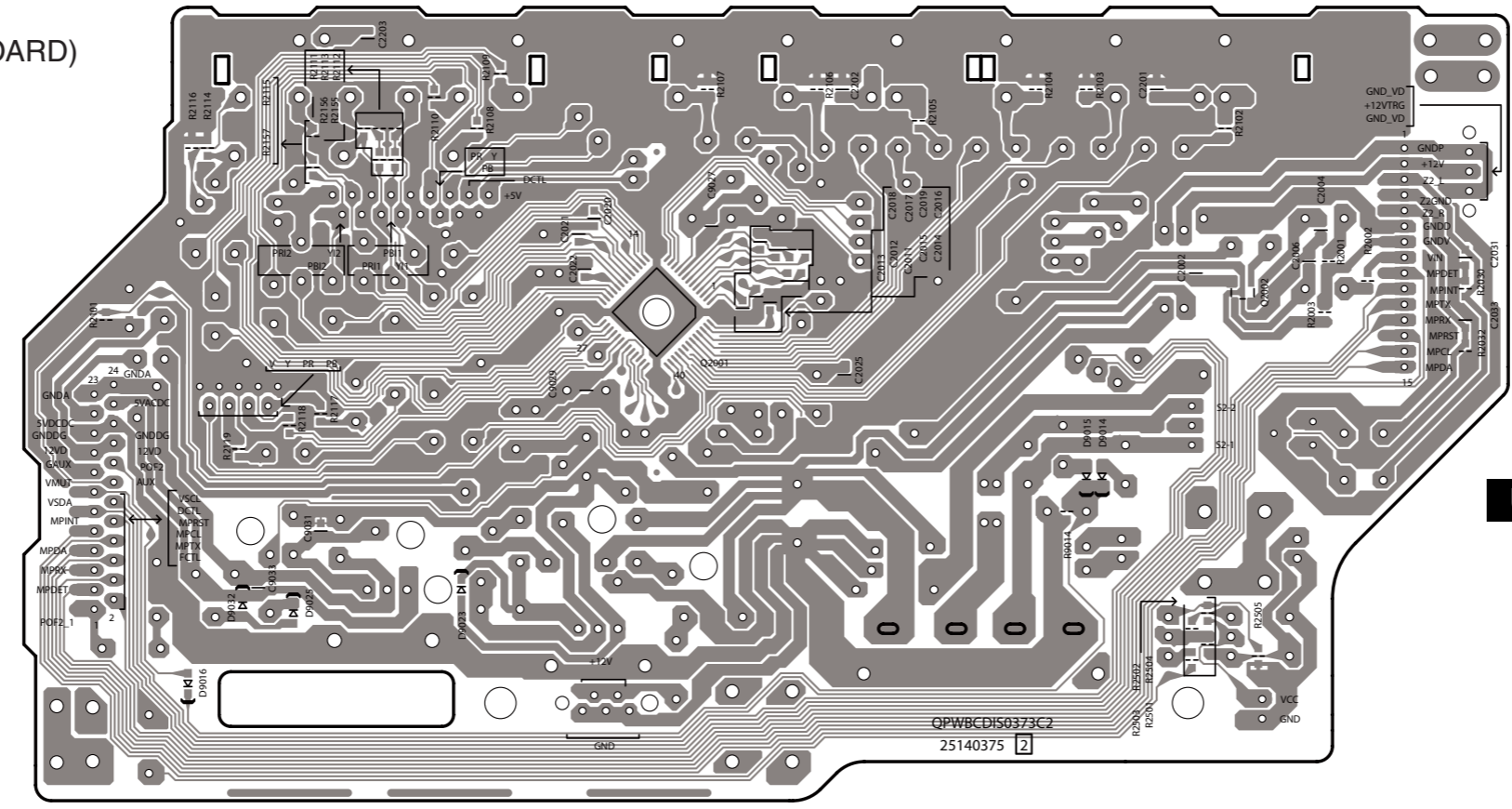

U0041 BADIS-0376 (STADBY KEY/LED PC BOARD)
B-side(Soldering side)

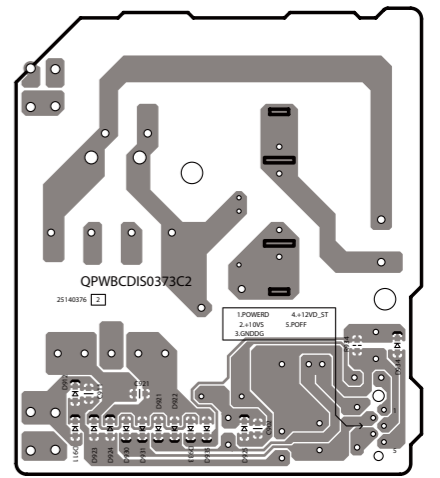

U0043 BAETC-0374 (POW SUPPLY PC BOARD)
B-side(Soldering side)

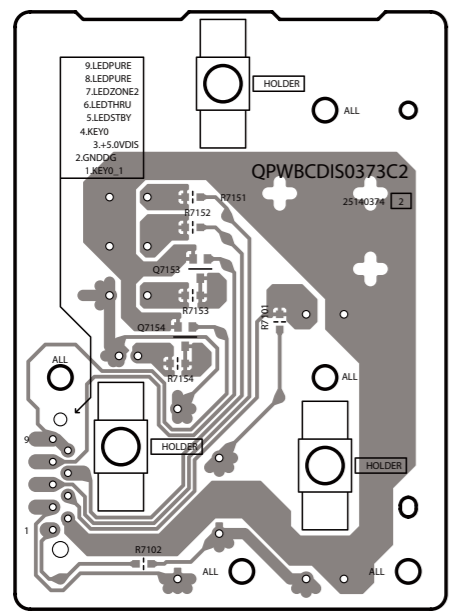

U0044 BAETC-0377 (HP JACK PC BOARD)
B-side(Soldering side)

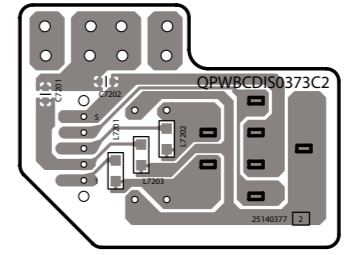

1

2

3

4

5

**PRINTED CIRCUIT BOARD VIEWS-7
HDMI SECTION**

1

U0070
BAHDM-0401 (HDMI PC BOARD)
A-side(Component side)

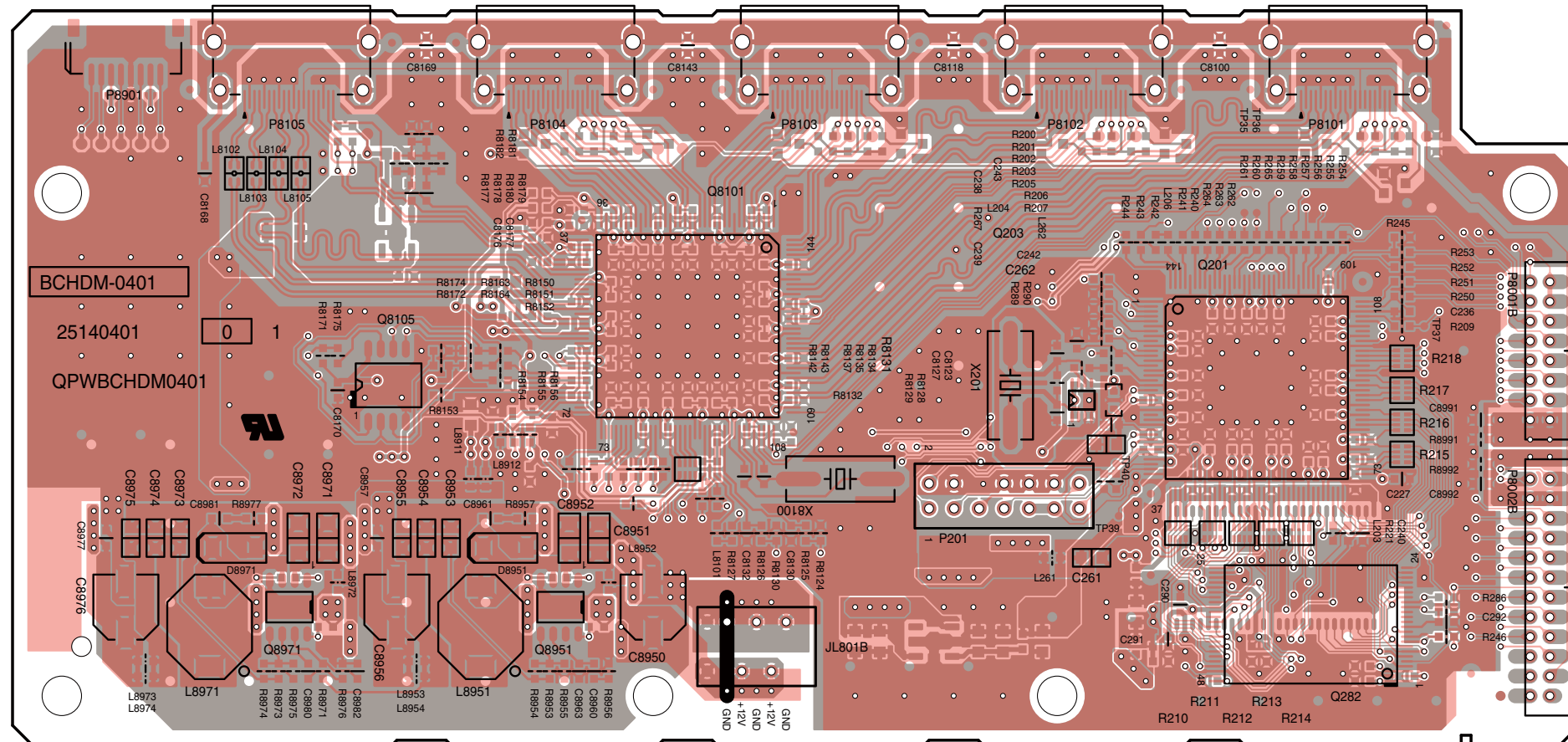

2

3

4

U0070
BAHDM-0401 (HDMI PC BOARD)
B-side(Soldering side)

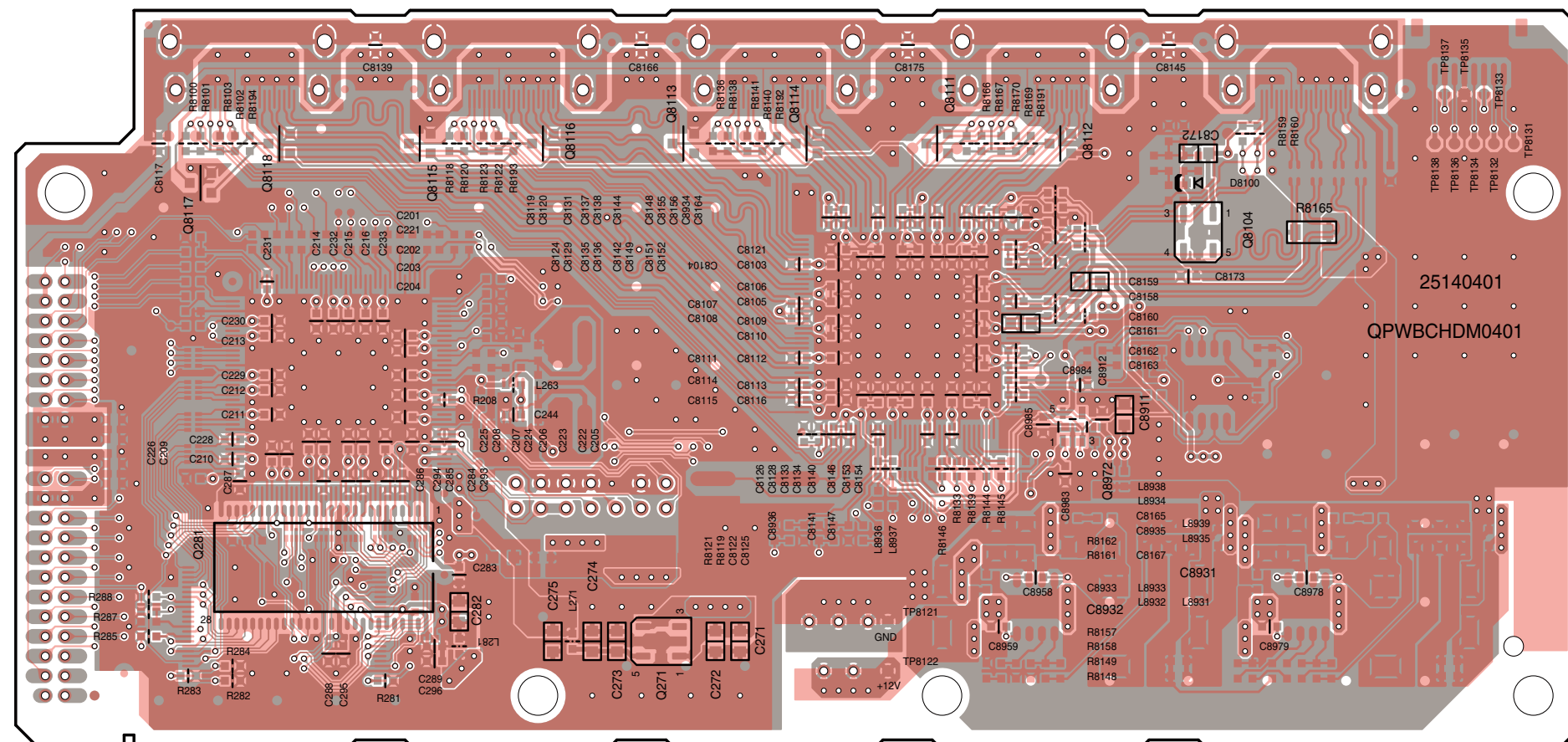

5

TX-SR308

<Note>

Parts marked by "NSP" are generally unavailable because they are not in our Master Spare Parts List.

NOTE : THE COMPONENTS IDENTIFIED BY THE MARK (!) ARE CRITICAL FOR RISK OF FIRE AND ELECTRIC SHOCK. REPLACE ONLY WITH PART NUMBER SPECIFIED.

<Notes>

(B) : Black model

(S) : Silver model

(G) : Golden model

<MDC> : 120V,Canadian model

<MDD> : 120V,USA model

<MDF> : 120V,Taiwanese model

<MMO> : 220/230-240V,Saudi Arabian model

<MMQ> : 220/230-240V,Hong kong model

<MPA> : 230V,Australian model

<MPP> : 230V,CE(European) country model

<MMR> : 220/230-240V,Chinese model

EXPLODED VIEW PARTS LIST

REF. NO.	PART NAME	DESCRIPTION	Q'TY	PART NO. (SN)	REMARKS
[TRANS COIL]					
T901	P TRANS (!)	NPT-1589D	1	2301970	N <MDC, MDD, MDF>
T901	P TRANS (!)	NPT-1589P	1	2301971	N <MPA, MPP>
T901	P TRANS (!)	NPT-1589M	1	2301972	N <MMO, MMQ , MMR>
[SEMI CONDUCTOR]					
Q6001	IC	STK-443-530-E	1	222148	
Q6002	IC	STK-442-530-E	1	222149	
[SW TRM]					
F6901	FUSE (!)	8A-T/UL-ST2	1	252261GR	!
F6902	FUSE (!)	8A-T/UL-ST2	1	252261GR	!
F901	FUSE (!)	4A-SE-EAK FUSE	1	252077GR	! <MMR MMO, MMQ, MPA, MPP>
F901	FUSE (!)	8A-UL/T-233	1	252329GR	! <MDC, MDD, MDF>
F901or	FUSE (!)	8A-T/UL-ST2	(1)	252261GR	! <MDC, MDD, MDF>
F901or	FUSE (!)	4A-SE-TL250V	(1)	252277GR	! <MMR MMO, MMQ, MPA, MPP>
P101	FFC	NCFC7-111512	1	2047111512	
P6601A	P RIVET	JB-407A-C (SP-TRM)	4	880052	<MMR MMO, MMQ, MPA, MPP>
P701	FFC	NCFC7-312012	1	2047312012	
P901	AC CORD (!)	AS-BS	1	253198LTK	! <MMQ>
P901	AC CORD (!)	AS-CEE-2	1	253306VOL	! <MMO, MPP>
P901or	AC CORD (!)	AS-CEE-2	(1)	253374YUN	! <MMO, MPP>
P901	AC CORD (!)	AS-CCC	1	253355VOL	! <MMR>
P901or	AC CORD (!)	AS-CCC	(1)	253377LTK	! <MMR>
P901	AC CORD (!)	AS-UC-2	1	253368AYUN	! <MDC, MDD>
P901or	AC CORD (!)	AS-UC-2	(1)	253368BLTK	! <MDC, MDD>
P901	AC CORD (!)	AS-SAA	1	253388LTK	! <MPA>
P901	AC CORD (!)	AS-CNS	1	253429VOL	! <MDF>
P901	AC CORD (!)	AS-CEE-2	1	253306VOL	! <MPP>

[CHASSIS SCREW]

A001	CHASSIS	TX-SR307	1			NSP	
A003	BOTTOM LEG	---	4	27175432C			
A005	CUSHION	---	4			NSP	
A007	SCREW	3TTB+8B(3CM)SR	4			NSP	
A009	HOLDER	KGLS-8RT	3			NSP	
A010	HOLDER	KGPS-8RF	1			NSP	
A011	HOLDER	KGLS-10RT	1			NSP	
A013	HOLDER	KGPS-14RF	2			NSP	
A015	HOLDER	KGPS-14RF	1			NSP	
A019	HOLDER	KGPS-16RF	1			NSP	
A021	HOLDER	KGLS-22S	2			NSP	
A025	SCREW	4TTC+8C(3BC)	4			NSP	
A030	HEAT SINK	307P-1	1			NSP	
A032	RETAINER	(HL)	1			NSP	
A034	RETAINER	(HR)	1			NSP	
A036	SCREW	3TTB+8B(3CM)SR	5			NSP	
A038	SCREW	3TTB+8B(3CM)SR	2			NSP	
A040	SCREW	3TTB+8B(3CM)SR	4			NSP	
A041	CLIP	CS-1U	1			NSP	
A042	SCREW	3TTB+8B(3CM)SR	2			NSP	
A044	HOLDER	KGLS-8RT	1			NSP	
A050	SCREW	3SMS8WSW+18B3CM	4			NSP	
A054	SCREW	3TTB+8B(3CM)SR	1			NSP	
A056	BUSHING	S-RELIEF #2271	1			NSP	
A060	WIRE TIE	BINDER(CLAMPER)UL	3			NSP	
A062	WIRE TIE	BSK-1	3			NSP	
A069	SCREW	3TTB+8B(3BC)	1			NSP	
A070	LABEL	(SP)307	1			NSP	
A101	REAR PANEL	TX-SR308DD/DC	1	27124084	N		<MDC, MDD, MDF>
A101	REAR PANEL	TX-SR308PP/PA	1	27124085	N		<MPA, MPP>
A101	REAR PANEL	TX-SR308MO	1	27124086	N		<MMO, MMQ>
A101	REAR PANEL	TX-SR308MR	1	27124087	N		<MMR>
A102	CUSHION	---	2			NSP	
A103	SCREW	3P+6FN(3BC)	4			NSP	
A105	SCREW	3TTB+8B(3BC)	25			NSP	
A105	SCREW	3TTB+8B(3BC)	26			NSP	(B)<MDF>
A109	SCREW	3P+6FN(3BC)	2			NSP	

[CABINET]

A201	F PANEL	TX-SR308(B)DD	1	27213317	N		(B) <MDC, MDD, MDF>
A201	F PANEL	TX-SR308(B)PP	1	27213318	N		(B) <MMO, MMQ, MPA, MPP>
A201	F PANEL	TX-SR308(S)PP	1	27213319	N		(S) <MPP>
A201	F PANEL	TX-SR308(G)DF	1	27213320	N		(G) <MDF>
A201	F PANEL	TX-SR308(G)MR	1	27213321	N		(G) <MMR>
A202	CLEAR PLT	(AS)308D	1	28192281	N		(B) <MDC, MDD, MDF>, (G) <MDF>
A202	CLEAR PLT	(AS)308P	1	28192282	N		(B) <MMO, MMQ, MPA, MPP>, (G) <MMR>, (S) <MPP>
A207	BADGE	BADGE	1	28135244			(B)

A207	BADGE	BADGE	1	28135245			(G)
A207	BADGE	---	1	28135298			(S)
A213	KNOB	(INP)	1	28326666			(B)(G)
A213	KNOB	(INP)	1	28326667			(S)
A215	KNOB	(SEL)	1	28326665			
A217	KNOB	(STNBY)	1	28326663A			
A219	KNOB	(CUR)	1	28326664A			
A221	IB CUSHION	W15*3t TAPE	1				NSP
A225	SCREW	2.6TTB+8B(3BC)	23				NSP
A230	RETAINER	(U)	1				NSP
A232	SCREW	2.6TTB+8B(3BC)	5				NSP
A234	RETAINER	(L)	1				NSP
A236	RETAINER	(R)	1				NSP
A238	SCREW	2.6TTB+8B(3BC)	4				NSP
A250	B PLATE	---	1				NSP (B)
A250	B PLATE	---	1				NSP (G)(S)
A254	WIRE TIE	BSK-1	8				NSP
A256	SCREW	3TTB+8B(3CM)SR	1				NSP
A258	SCREW	3TTB+8B(3CM)SR	4				NSP
A260	SCREW	3TTB+8B(3BC)	3				NSP
A262	TAPE	TAPE(CLOTH-16U)	1				NSP
A264	CUSHION	---	2				NSP
A273	HOLDER	KGLS-4S	3				NSP
A321	KNOB	(VOL)AS(B)	1	28326817			(B)
A321	KNOB	(VOL)AS(G)	1	28326819	N		(G)
A321	KNOB	(VOL)AS(S)	1	28326818			(S)
A340	COVER	(B) (Bent)	1	28210031			(B)
A340	COVER	(B) (Not Bent)	1	28210031Z			(B) < MDD MDC>
A340	COVER	(G) (Bent)	1	28210033			(G)
A340	COVER	(S) (Bent)	1	28210032			(S)
A342	SCREW	3TTB+8B(3BC)	7				NSP (B)
A344	SCREW	3TTB+8B(3CM)SR	7				NSP (S)(G)
A350	PLATE	(COVER) B	1				NSP (B) <MMQ>
A354	HOLDER	(PLATE)	6				NSP (B) <MMQ>
A360	LABEL	(COVER)	1				NSP
A362	LABEL	HOOKUP-ONKYO (COVER)	1				NSP (B) <MDC, MDD>

[TUNER UNIT]

U001	AF-AS (AMPLIFIER ASSY) (U0010/11/12/13/14/15)	BAAF-0341-1A *	1	1B247541-1A	N		<MDC, MDD, MDF>
U001	AF-AS (AMPLIFIER ASSY) (U0010/11/12/13/14/15)	BAAF-0341-1B *	1	1B247541-1B	N		<MPA, MPP>
U001	AF-AS (AMPLIFIER ASSY) (U0010/11/12/13/14/15)	BAAF-0341-1C *	1	1B247541-1C	N		<MMO, MMQ MMR>
U0010	AF-AS (AMPLIFIER)	BAAF-0341-1A	1	1B2475341-1A	N		<MDC, MDD, MDF>
U0010	AF-AS (AMPLIFIER)	BAAF-0341-1B	1	1B2475341-1B	N		<MPA, MPP>

U0010	AF-AS (AMPLIFIER)	BAAF-0341-1C	1	1B2475341-1C	N	<MMO, MMQ MMR>
U0011	PWB (FL TUB -VP)	BAPS-0342-1A	1	1B2475342-1A	N	<MDC, MDD, MDF>
U0011	PWB (FL TUB -VP)	BAPS-0342-1B	1	1B2475342-1B	N	<MPA, MPP>
U0011	PWB (FL TUB -VP)	BAPS-0342-1C	1	1B2475342-1C	N	<MMO, MMQ MMR>
U0012	PWB (TEMP-SEN)	BAETC-0343-1A	1	1B2475343-1A	N	<MDC, MDD, MDF>
U0012	PWB (TEMP-SEN)	BAETC-0343-1B	1	1B2475343-1B	N	<MPA, MPP>
U0012	PWB (TEMP-SEN)	BAETC-0343-1C	1	1B2475343-1C	N	<MMO, MMQ MMR>
U0013	PWB	BAETC-0344-1A	1		N NSP	<MDC, MDD, MDF>
U0013	PWB	BAETC-0344-1B	1		N NSP	<MPA, MPP>
U0013	PWB	BAETC-0344-1C	1		N NSP	<MMO, MMQ MMR>
U0014	PWB (TRANS-TRM)	BAETC-0345-1A	1	1B2475345-1A	N	<MDC, MDD, MDF>
U0014	PWB (TRANS-TRM)	BAETC-0345-1B	1	1B2475345-1B	N	<MPA, MPP>
U0014	PWB (TRANS-TRM)	BAETC-0345-1C	1	1B2475345-1C	N	<MMO, MMQ MMR>
U0015	PWB	BAETC-0346-1A	1		N NSP	<MDC, MDD, MDF>
U0015	PWB	BAETC-0346-1B	1		N NSP	<MPA, MPP>
U0015	PWB	BAETC-0346-1C	1		N NSP	<MMO, MMQ MMR>
U003	DG-AS (MPU/DAC ASSY) (U0030/31)	BADG-0364-1A *	1	1B247564-1A	N	<MDC, MDD, MDF>
U003	DG-AS (MPU/DAC ASSY) (U0030/32)	BADG-0364-1B *	1	1B247564-1B	N	<MMO, MMQ, MPA, MPP, MMR>
U0030	DG-AS (MPU/DAC)	BADG-0364-1A	1	1B2475364-1A	N	<MDC, MDD, MDF>
U0030	DG-AS (MPU/DAC)	BADG-0364-1B	1	1B2475364-1B	N	<MMO, MMQ, MPA, MPP, MMR>
U0031	PWB (U-PORT)	BAETC-0365-1A	1	1B2475365-1A	N	<MDC, MDD, MDF>
U0031	PWB (U-PORT)	BAETC-0365-1B	1	1B2475365-1B	N	<MMO, MMQ, MPA, MPP, MMR>
U004	DIS-AS (DISPLAY ASSY) (U0040/41/42/43/44)	BADIS-0373-1A *	1	1B247573-1A	N	<MDC, MDD, MDF>
U004	DIS-AS (DISPLAY ASSY) (U0040/41/42/43/44)	BADIS-0373-1B *	1	1B247573-1B	N	<MMO, MMQ, MPA, MPP, MMR>
U0040	DIS-AS (DISPLAY)	BADIS-0373-1A	1	1B2475373-1A	N	<MDC, MDD, MDF>
U0040	DIS-AS (DISPLAY)	BADIS-0373-1B	1	1B2475373-1B	N	<MMO, MMQ, MPA, MPP, MMR>
U0041	PWB (STANDBY_KEY/LED)	BADIS-0374-1A	1	Included in "REF, NO, U0041"	N	<MDC, MDD, MDF>
U0041	PWB (STANDBY_KEY/LED)	BADIS-0374-1B	1	Included in "REF, NO, U0041"	N	<MMO, MMQ, MPA, MPP, MMR>
U0042	PWB (VIDEO)	BAVD-0375-1A	1	1B2475375-1A	N	<MDC, MDD, MDF>
U0042	PWB (VIDEO)	BAVD-0375-1B	1	1B2475375-1B	N	<MMO, MMQ, MPA, MPP, MMR>
U0043	PWB (POW-SUPPLY)	BAETC-0376-1A	1	1B2475376-1A	N	<MDC, MDD, MDF>
U0043	PWB (POW-SUPPLY)	BAETC-0376-1B	1	1B2475376-1B	N	<MMO, MMQ, MPA, MPP, MMR>
U0044	PWB (HP-JACK)	BAETC-0377-1A	1	1B2475377-1A	N	<MDC, MDD, MDF>
U0044	PWB (HP-JACK)	BAETC-0377-1B	1	1B2475377-1B	N	<MMO, MMQ, MPA, MPP, MMR>
U007	HDM-AS (HDMI ASSY)	BAHDM-0401-1A *	1	1B247501-1A	N	
U010	TUNER UNIT	FAEH06-E01EX	1	240165		<MMO, MMQ, MPA, MPP, MMR>
U010	TUNER UNIT	FAEH06-A01US	1	240166		<MDC, MDD, MDF>

TX-SR308

PACKING PARTS LIST

[PACKING]

A601	PAD	(AS)307	1	29092452A		
A605	POLY BAG	w850xd650	1	29100245		

A606	TAPE	(SEROHAN)NITTO NO.29	1	29110149		
A608	SHEET	---	1	29095906		<MDC, MDD, MDF, MMO, MPA, MPP, MMR>
A608	SHEET	T0.5x600x500	1	29096097		<MMQ>
A611	TAPE	(SEROHAN)NITTO NO.29	1	29110149		
A701	CARTON	308DD	1	29055092	N	<MDC, MDD, MDF>
A701	CARTON	308	1	29055093	N	<MMO, MMQ, MPA, MPP, MMR>
A704A	UPC LABEL	308BMDD	{ 1 }	29391043	N	(B) <MDD>
A704A	UPC LABEL	308BMDC	{ 1 }	29391044	N	(B) <MDC>
A704A	EAN LABEL	308BMPP	{ 1 }	29391045A	N	(B) <MPP>
A704A	EAN LABEL	308BMPA	{ 1 }	29391047	N	(B) <MPA>
A704A	EAN LABEL	308BMMO	{ 1 }	29391048A	N	(B) <MMO>
A704A	EAN LABEL	308BMDF	{ 1 }	29391049	N	(B) <MDF>
A704A	LABEL	308BMMQ	{ 1 }	29391162	N	(B) <MMQ>
A704A	EAN LABEL	308BMDF	{ 1 }	29391049	N	(G) <MDF>
A704A	EAN LABEL	308GMMR	{ 1 }	29391050	N	(G) <MMR>
A704A	EAN LABEL	308SMPP	{ 1 }	29391046A	N	(S) <MPP>
A707	LABEL	(CHINA)	1	29390370		<MMR>
A751	LABEL	(TWN)TXSR308B	2	29391133		(B) <MDF>
A755	LABEL	(CCC)	1	29364396		<MMR>
A760	PP TAPE	W50 SBT-70	1	29110200		
[ACCESSARY]						
A672	POLY BAG	w250xd350	1	29100250A		<MMO, MMQ, MPA, MPP>
A674	POLY BAG	D250xd300xW300(t0.04)	1	29100256A		
A676	TAPE	(SEROHAN)NITTO NO.29	1	29110149		
A801	INS MANUAL	En(TX-SR308)	1	29400195		
A802	INS MANUAL	U2FrEs(TX-SR308)	1	29400196		<MDC, MPP>
A803	INS MANUAL	U2ItDe(TX-SR308)	1	29400197		<MPP>
A804	INS MANUAL	U2NISv(TX-SR308)	1	29400198		<MPP>
A805	INS MANUAL	Ct(TX-SR308)	1	29400199	N	<MDF, MMQ>
A806	INS MANUAL	Cs(TX-SR308)	1	29400200	N	<MMR>
A807	INS MANUAL	Ar(TX-SR308)	1	29400201	N	<MMQ>
A808	INS MANUAL	Ar(QC ImportantSheet)	1	29344373		<MMQ>
A809	INS MANUAL	En(QSS TX-SR308)	1	29400202		
A812	INS MANUAL	Cs(QSS TX-SR308)	1	29400203	N	<MMR>
A825	INST SHEET	Ct(CHUISI MDF)	1	29355781		<MDF>
A826	INST SHEET	En(2010E_RIHD)	1	29355782		
A830	INST SHEET	WEEE	1	29355537A		<MPP>
A835	HANDBILL	(UP-A1)US	1	29380155		<MDC, MDD, MPP>
A855	REMO CON	RC-762M	1	24140762	N	
A858	ANT COIL	NMA-3057	1	232140		
A859	FM ANT AS	Type W	1	292191		
A860	LABEL	(SPCABLE)2009	1	29390881		
A861	BATTERY	R6/AA(UM-3)	2	3010194		
A861or	BATTERY	R6/AA(UM-3)	(2)	3010054		
A880	INST SHEET	CHINA ROHS	1	29355616A		<MMR>
A883	WRNTY CARD	(ONKYO-CH)	1	29365098B		<MMR>
A884	WRNTY CARD	MGQ	1	29365099A		<MMQ>
A885	WRNTY CARD	(ONKYO)	1	29365135		<MDC, MDD>
A888	LABEL	(APV)	1	29390190		<MMR>

TX-SR308

PC BOARD PARTS LIST

U001	AF-AS (AMPLIFIER ASSY) (U0010/11/12/13/14/15)	BAAF-0341-1A *	1	1B247541-1A	N	<MDC, MDD, MDF>
U001	AF-AS (AMPLIFIER ASSY) (U0010/11/12/13/14/15)	BAAF-0341-1B *	1	1B247541-1B	N	<MPA, MPP>
U001	AF-AS (AMPLIFIER ASSY) (U0010/11/12/13/14/15)	BAAF-0341-1C *	1	1B247541-1C	N	<MMO, MMQ MMR>
U0010	AF-AS (AMPLIFIER)	BAAF-0341-1A	1	1B2475341-1A	N	<MDC, MDD, MDF>
U0010	AF-AS (AMPLIFIER)	BAAF-0341-1B	1	1B2475341-1B	N	<MPA, MPP>
U0010	AF-AS (AMPLIFIER)	BAAF-0341-1C	1	1B2475341-1C	N	<MMO, MMQ MMR>
U0011	PWB (FL TUB -VP)	BAPS-0342-1A	1	1B2475342-1A	N	<MDC, MDD, MDF>
U0011	PWB (FL TUB -VP)	BAPS-0342-1B	1	1B2475342-1B	N	<MPA, MPP>
U0011	PWB (FL TUB -VP)	BAPS-0342-1C	1	1B2475342-1C	N	<MMO, MMQ MMR>
U0012	PWB (TEMP-SEN)	BAETC-0343-1A	1	1B2475343-1A	N	<MDC, MDD, MDF>
U0012	PWB (TEMP-SEN)	BAETC-0343-1B	1	1B2475343-1B	N	<MPA, MPP>
U0012	PWB (TEMP-SEN)	BAETC-0343-1C	1	1B2475343-1C	N	<MMO, MMQ MMR>
U0013	PWB	BAETC-0344-1A	1		N NSP	<MDC, MDD, MDF>
U0013	PWB	BAETC-0344-1B	1		N NSP	<MPA, MPP>
U0013	PWB	BAETC-0344-1C	1		N NSP	<MMO, MMQ MMR>
U0014	PWB (TRANS-TRM)	BAETC-0345-1A	1	1B2475345-1A	N	<MDC, MDD, MDF>
U0014	PWB (TRANS-TRM)	BAETC-0345-1B	1	1B2475345-1B	N	<MPA, MPP>
U0014	PWB (TRANS-TRM)	BAETC-0345-1C	1	1B2475345-1C	N	<MMO, MMQ MMR>
U0015	PWB	BAETC-0346-1A	1		N NSP	<MDC, MDD, MDF>
U0015	PWB	BAETC-0346-1B	1		N NSP	<MPA, MPP>
U0015	PWB	BAETC-0346-1C	1		N NSP	<MMO, MMQ MMR>

CIRCUIT. N°	PART NAME	DESCRIPTION	Q'TY	PART NO. (SN)	REMARKS
[SEMI CONDUCTOR]					
D4171	ZENER D	MTZJ6.2B	1	224470622T	
D4172	ZENER D	MTZJ6.2B	1	224470622T	
D4173	DIODE	1SS133	1	223163T	
D4174	DIODE	1SS133	1	223163T	
D4300	DIODE	RL1N4003	1	22380260T	
D4300 or	DIODE	GP104003E	(1)	22380035T	
D4301	DIODE	RL1N4003	1	22380260T	
D4301 or	DIODE	GP104003E	(1)	22380035T	
D4302	DIODE	RL1N4003	1	22380260T	
D4302 or	DIODE	GP104003E	(1)	22380035T	
D4303	DIODE	RL1N4003	1	22380260T	

D4303 or	DIODE	GP104003E	(1)	22380035T		
D4304	DIODE	1SS133	1	223163T		
D4305	DIODE	1SS133	1	223163T		
D6020	C-DIODE	KDS4148U	1			NSP
D6020 or	C-DIODE	1SS352	(1)			NSP
D6020 or	C-DIODE	MA2J111	(1)			NSP
D6021	C-DIODE	KDS4148U	1			NSP
D6021 or	C-DIODE	1SS352	(1)			NSP
D6021 or	C-DIODE	MA2J111	(1)			NSP
D6022	C-DIODE	KDS4148U	1			NSP
D6022 or	C-DIODE	1SS352	(1)			NSP
D6022 or	C-DIODE	MA2J111	(1)			NSP
D6023	C-DIODE	KDS4148U	1			NSP
D6023 or	C-DIODE	1SS352	(1)			NSP
D6023 or	C-DIODE	MA2J111	(1)			NSP
D6024	C-DIODE	KDS4148U	1			NSP
D6024 or	C-DIODE	1SS352	(1)			NSP
D6024 or	C-DIODE	MA2J111	(1)			NSP
D6031	DIODE	1SS133	1	223163T		
D6032	DIODE	1SS133	1	223163T		
D6033	ZENER D	UDZS3.3B	1	224550330R2		
D6034	ZENER D	UDZS3.3B	1	224550330R2		
D6051	C-DIODE	KDS4148U	1			NSP
D6051 or	C-DIODE	1SS352	(1)			NSP
D6051 or	C-DIODE	MA2J111	(1)			NSP
D6052	C-DIODE	KDS4148U	1			NSP
D6052 or	C-DIODE	1SS352	(1)			NSP
D6052 or	C-DIODE	MA2J111	(1)			NSP
D6053	C-DIODE	KDS4148U	1			NSP
D6053 or	C-DIODE	1SS352	(1)			NSP
D6053 or	C-DIODE	MA2J111	(1)			NSP
D6055	C-DIODE	KDS4148U	1			NSP
D6055 or	C-DIODE	1SS352	(1)			NSP
D6055 or	C-DIODE	MA2J111	(1)			NSP
D6704	ZENER D	UDZS3.3B	1	224550330R2		
D6901	DIODE	D5SBA20	1	22380130		
D6901A	HEAT SINK	RAD-083	1			NSP
D6901C	SCREW	3P+10FN(3BC)	1			NSP
D6902	C-DIODE	KDS4148U	1			NSP
D6902 or	C-DIODE	1SS352	(1)			NSP
D6902 or	C-DIODE	MA2J111	(1)			NSP

D960	DIODE	RL1N4003	1	22380260T			
D961	DIODE	RL1N4003	1	22380260T			
D962	ZENER D	UDZS36B	1	224553600R2			
Q4001	IC	R2A15218FP	1	22242605R3			
Q4003	IC	NJM4580M-D	1	22241448R2			
Q4100	TR	RN1441	1	2215410R2			
Q4101	TR	RN1441	1	2215410R2			
Q4102	TR	RN1441	1	2215410R2			
Q4103	TR	RN1441	1	2215410R2			
Q4104	TR	RN1441	1	2215410R2			
Q4107	TR	RN1441	1	2215410R2			
Q4117	TR	RN1441	1	2215410R2			
Q4130	IC	NJM4580M-D	1	22241448R2			
Q4170	IC	78M12HF(NJM78M12FA)	1	222780125JRC			<MMO, MMQ MMR>
Q4170	IC	78M15HF(NJM78M15FA)	1	222780155JRC			<MDC, MDD, MDF, MPA, MPP>
Q4170 or	IC	78M12(AN78M12F)	(1)	222780125MAT			<MMO, MMQ MMR>
Q4170 or	IC	MPC78M12AHF-AZ	(1)	222780125NEC			<MMO, MMQ MMR>
Q4170 or	IC	UPC78M15AHF-AZ	(1)	222780155NEC			<MDC, MDD, MDF, MPA, MPP>
Q4171	IC	79M12HF(NJM79M12FA)	1	222790125JRC			<MMO, MMQ MMR>
Q4171	IC	79M15HF(NJM79M15FA)	1	222790155JRC			<MDC, MDD, MDF, MPA, MPP>
Q4171 or	IC	79M12F(AN79M12F)	(1)	222790125MAT			<MMO, MMQ MMR>
Q4171 or	IC	79M12HF(MPC79M12HF)	(1)	222790125NEC			<MMO, MMQ MMR>
Q4171 or	IC	UPC79M15HF-AZ	(1)	222790155NEC			<MDC, MDD, MDF, MPA, MPP>
Q6001	IC	STK-443-530-E	1	222148			
Q6002	IC	STK-442-530-E	1	222149			
Q6010	TR	2SC2240-BL(TPE2_F)	1	2211406T			
Q6011	TR	2SC2240-BL(TPE2_F)	1	2211406T			
Q6012	TR	2SC2240-BL(TPE2_F)	1	2211406T			
Q6013	TR	2SC2240-BL(TPE2_F)	1	2211406T			
Q6014	TR	2SC2240-BL(TPE2_F)	1	2211406T			
Q6021	TR	2SA1163-BL(TE85L_F)	1	2216756R2			
Q6022	TR	2SC2240-BL(TPE2_F)	1	2211406T			
Q6023	TR	2SC2240-BL(TPE2_F)	1	2211406T			
Q6024	TR	2SA1163-BL(TE85L_F)	1	2216756R2			
Q6051	TR	KRC105S	1	2217290R2			
Q6051 or	TR	RN1405	(1)	2214500R2			
Q6051 or	TR	DTC123JKA	(1)	2216690R2			
Q6052	TR	KRC105S	1	2217290R2			
Q6052 or	TR	RN1405	(1)	2214500R2			
Q6052 or	TR	DTC123JKA	(1)	2216690R2			
Q6053	TR	KRC105S	1	2217290R2			

Q6053 or	TR	RN1405	(1)	2214500R2			
Q6053 or	TR	DTC123JKA	(1)	2216690R2			
Q6055	TR	KRC105S	1	2217290R2			
Q6055 or	TR	RN1405	(1)	2214500R2			
Q6055 or	TR	DTC123JKA	(1)	2216690R2			
Q6380	IC	LM61CIZ	1	22242212			
Q6380A	RETAINER	(PTH)	1	27141884-1			
Q6707	TR	KTC3875-GR	1	2216175R2			
Q6707 or	TR	2SC2712-GR	(1)	2213145R2			
Q960	TR	2SC2235-Y(TPE6_F)	1	2211654T			
Q960 or	TR	2SC2235-O(TPE6_F)	(1)	2211653T			
[TRANS COIL]							
L4001	CHOKE COIL	LBC2518T2R2M	1	231364M022R2			
L6000	S COIL	SC-0.8X6.0X29.5T-4RV-C	1	231394AS			
L6000 or	S COIL	PB9510	(1)	231361			
L6001	S COIL	SC-0.8X6.0X29.5T-4RV-C	1	231394AS			
L6001 or	S COIL	PB9510	(1)	231361			
L6002	S COIL	SC-0.8X6.0X29.5T-4RV-C	1	231394S			
L6002 or	S COIL	PB9510	(1)	231361			
L6003	S COIL	SC-0.8X6.0X29.5T-4RV-C	1	231394AS			
L6003 or	S COIL	PB9510	(1)	231361			
L6004	S COIL	SC-0.8X6.0X29.5T-4RV-C	1	231394AS			
L6004 or	S COIL	PB9510	(1)	231361			
[CAPACITOR]							
C4001	C-CERA C	CC725CH1H-152J1	1			NSP	
C4002	C-CERA C	CC725CH1H-152J1	1			NSP	
C4003	UPZ C	2AUPZTF221JE	1	376332214T			
C4004	UPZ C	2AUPZTF221JE	1	376332214T			
C4007	C-CERA C	CC725CH1H-221J1	1			NSP	
C4008	C-CERA C	CC725CH1H-221J1	1			NSP	
C4013	C-CERA C	CC725CH1H-221J1	1			NSP	
C4014	C-CERA C	CC725CH1H-221J1	1			NSP	
C4017	C-CERA C	CC725CH1H-221J1	1			NSP	
C4018	C-CERA C	CC725CH1H-221J1	1			NSP	
C4019	UPZ C	2AUPZTF221JE	1	376332214T			
C4020	UPZ C	2AUPZTF221JE	1	376332214T			
C4037	C-CERA C	CC725CH1H-221J1	1			NSP	
C4050	UTSP C	CE04W25V-47M(UTSP)	1	397554707T			
C4051	UTSP C	CE04W25V-47M(UTSP)	1	397554707T			
C4052	UTSP C	CE04W25V-47M(UTSP)	1	397554707T			
C4053	UTSP C	CE04W25V-47M(UTSP)	1	397554707T			

C4054	UTSP C	CE04W25V-47M(UTSP)	1	397554707T		
C4057	UTSP C	CE04W25V-47M(UTSP)	1	397554707T		
C4060	UTSP C	CE04W50V 47M(UTSP)	1	397584707T		
C4061	UTSP C	CE04W50V 47M(UTSP)	1	397584707T		
C4062	TF C	ECQ-V50V-474J	1	374724744T		
C4063	TF C	ECQ-V50V-823J	1	374728234T		
C4064	TF C	ECQ-V50V-223J	1	374722234T		
C4065	TF C	ECQ-V50V-474J	1	374724744T		
C4066	TF C	ECQ-V50V-823J	1	374728234T		
C4067	TF C	ECQ-V50V-223J	1	374722234T		
C4070	UTSP C	CE04W50V 47M(UTSP)	1	397584707T		
C4071	UTSP C	CE04W50V 47M(UTSP)	1	397584707T		
C4072	UTSP C	CE04W50V 47M(UTSP)	1	397584707T		
C4073	UTSP C	CE04W50V 47M(UTSP)	1	397584707T		
C4074	UTSP C	CE04W50V 47M(UTSP)	1	397584707T		
C4077	UTSP C	CE04W50V 47M(UTSP)	1	397584707T		
C4085	UTSP C	CE04W25V-47M(UTSP)	1	397554707T		
C4086	UTSP C	CE04W25V-47M(UTSP)	1	397554707T		
C4090	C-CERA C	CC725CH1H-101J1	1			NSP
C4091	C-CERA C	CC725CH1H-101J1	1			NSP
C4100	UTSP C	CE04W50V 47M(UTSP)	1	397584707T		
C4101	UTSP C	CE04W50V 47M(UTSP)	1	397584707T		
C4102	UTSP C	CE04W50V 47M(UTSP)	1	397584707T		
C4103	UTSP C	CE04W50V 47M(UTSP)	1	397584707T		
C4104	UTSP C	CE04W50V 47M(UTSP)	1	397584707T		
C4107	UTSP C	CE04W50V 47M(UTSP)	1	397584707T		
C4130	UTSP C	CE04W50V 47M(UTSP)	1	397584707T		
C4131	C-CERA C	CC725CH1H-221J1	1	342102214R1		NSP
C4132	TF C	ECQ-V50V-103J	1	374721034T		
C4166	UTSP C	CE04W25V-220M(UTSP)	1	397552217T		
C4167	UTSP C	CE04W25V-220M(UTSP)	1	397552217T		
C4170	UTSP C	CE04W50V-1M(UTSP)	1	397580107T		
C4171	UTSP C	CE04W50V-1M(UTSP)	1	397580107T		
C4172	UTSP C	CE04W25V-220M(UTSP)	1	397552217T		
C4173	UTSP C	CE04W25V-220M(UTSP)	1	397552217T		
C4186	UTSP C	CE04W16V-470M(UTSP)	1	397544717T		
C4187	UTSP C	CE04W16V-470M(UTSP)	1	397544717T		
C4203	C-CERA C	CC725CH1H-102J1	1			NSP
C4204	C-CERA C	CC725CH1H-102J1	1			NSP
C4205	C-CERA C	CC725CH1H-102J1	1			NSP
C4208	C-CERA C	CC725CH1H-102J1	1			NSP

C4209	UTSP C	CE04W25V-47M(UTSP)	1	397554707T			
C4210	UTSP C	CE04W25V-47M(UTSP)	1	397554707T			
C4300	TF C	ECQ-V50V-334J	1	374723344T			
C4301	VR C	CE04W35V-1000M(VR)	1	394661027S			
C4302	VR C	CE04W35V-470M(VR)	1	394664717T			
C6009	TF C	ECQ-V50V-333J	1	374723334T			
C6010	UTSP C	CE04W50V 47M(UTSP)	1	397584707T			
C6011	UTSP C	CE04W50V 47M(UTSP)	1	397584707T			
C6012	UTSP C	CE04W50V 47M(UTSP)	1	397584707T			
C6013	UTSP C	CE04W50V 47M(UTSP)	1	397584707T			
C6014	UTSP C	CE04W50V 47M(UTSP)	1	397584707T			
C6020	UPZ C	2AUPZTF471JE	1	376334714T			
C6021	UPZ C	2AUPZTF471JE	1	376334714T			
C6022	UPZ C	2AUPZTF471JE	1	376334714T			
C6023	UPZ C	2AUPZTF471JE	1	376334714T			
C6024	UPZ C	2AUPZTF471JE	1	376334714T			
C6030	UTSP C	CE04W25V-220M(UTSP)	1	397552217T			
C6031	UTSP C	CE04W25V-220M(UTSP)	1	397552217T			
C6032	UTSP C	CE04W25V-220M(UTSP)	1	397552217T			
C6033	UTSP C	CE04W25V-220M(UTSP)	1	397552217T			
C6034	UTSP C	CE04W25V-220M(UTSP)	1	397552217T			
C6040	CERA C	CC45CH50V-030D	1				NSP
C6041	CERA C	CC45CH50V-030D	1				NSP
C6042	CERA C	CC45CH50V-030D	1				NSP
C6043	CERA C	CC45CH50V-030D	1				NSP
C6044	CERA C	CC45CH50V-030D	1				NSP
C6050	C-CERA C	CK725B1H-472K1	1				NSP
C6051	C-CERA C	CK725B1H-472K1	1				NSP
C6052	C-CERA C	CK725B1H-472K1	1				NSP
C6053	C-CERA C	CK725B1H-472K1	1				NSP
C6054	C-CERA C	CK725B1H-472K1	1				NSP
C6060	TF C	ECQ-V50V-473J	1	374724734T			
C6061	TF C	ECQ-V50V-473J	1	374724734T			
C6062	TF C	ECQ-V50V-473J	1	374724734T			
C6063	TF C	ECQ-V50V-473J	1	374724734T			
C6064	TF C	ECQ-V50V-473J	1	374724734T			
C6070	TF C	ECQ-V50V-103J	1	374721034T			
C6071	TF C	ECQ-V50V-103J	1	374721034T			
C6072	TF C	ECQ-V50V-103J	1	374721034T			
C6073	TF C	ECQ-V50V-103J	1	374721034T			
C6074	TF C	ECQ-V50V-103J	1	374721034T			

C6080	MKT C	B32529C0102J289	1	376491024T		<MDC, MDD, MDF>
C6080	MKT C	B32529C0472J289	1	376494724T		<MPAS, MPP, MMO, MMQ, MMR >
C6080	MKT C	B32529C0472J289	1	376494724T		<MPAS, MPP, MMO, MMQ, MMR >
C6081	MKT C	B32529C0102J289	1	376491024T		<MDC, MDD, MDF>
C6081	MKT C	B32529C0472J289	1	376494724T		<MPAS, MPP, MMO, MMQ, MMR >
C6081	MKT C	B32529C0472J289	1	376494724T		<MPAS, MPP, MMO, MMQ, MMR >
C6082	MKT C	B32529C0102J289	1	376491024T		<MDC, MDD, MDF>
C6082	MKT C	B32529C0472J289	1	376494724T		<MPAS, MPP, MMO, MMQ, MMR >
C6082	MKT C	B32529C0472J289	1	376494724T		<MPAS, MPP, MMO, MMQ, MMR >
C6083	MKT C	B32529C0102J289	1	376491024T		<MDC, MDD, MDF>
C6083	MKT C	B32529C0472J289	1	376494724T		<MPAS, MPP, MMO, MMQ, MMR >
C6083	MKT C	B32529C0472J289	1	376494724T		<MPAS, MPP, MMO, MMQ, MMR >
C6084	MKT C	B32529C0102J289	1	376491024T		<MDC, MDD, MDF>
C6084	MKT C	B32529C0472J289	1	376494724T		<MPAS, MPP, MMO, MMQ, MMR >
C6084	MKT C	B32529C0472J289	1	376494724T		<MPAS, MPP, MMO, MMQ, MMR >
C6088	MKT C	B32529C0102J289	1	376491024T		<MDC, MDD, MDF>
C6088	MKT C	B32529C0472J289	1	376494724T		<MPAS, MPP, MMO, MMQ, MMR >
C6088	MKT C	B32529C0472J289	1	376494724T		<MPAS, MPP, MMO, MMQ, MMR >
C6089	MKT C	B32529C0102J289	1	376491024T		<MDC, MDD, MDF>
C6089	MKT C	B32529C0472J289	1	376494724T		<MPAS, MPP, MMO, MMQ, MMR >
C6089	MKT C	B32529C0472J289	1	376494724T		<MPAS, MPP, MMO, MMQ, MMR >
C6090	UTSP C	CE04W25V-100M(UTSP)	1	397551017T		
C6091	UTSP C	CE04W50V-1M(UTSP)	1	397580107T		
C6092	UTSP C	CE04W50V-1M(UTSP)	1	397580107T		
C6093	C-CERA C	CK725F1E-104Z1	1			NSP
C6094	C-CERA C	CK725F1E-104Z1	1			NSP
C6101	UTSP C	CE04W63V-100M(UTSP)	1	397571017T		
C6102	UTSP C	CE04W63V-100M(UTSP)	1	397571017T		
C6103	UTSP C	CE04W50V 47M(UTSP)	1	397584707T		
C6104	UTSP C	CE04W63V-100M(UTSP)	1	397571017T		
C6105	UTSP C	CE04W63V-100M(UTSP)	1	397571017T		
C6106	UTSP C	CE04W50V 47M(UTSP)	1	397584707T		
C6107	UTSP C	CE04W63V-100M(UTSP)	1	397571017T		
C6108	UTSP C	CE04W63V-100M(UTSP)	1	397571017T		
C6111	TF C	ECQ-V50V-103J	1	374721034T		
C6112	TF C	ECQ-V50V-103J	1	374721034T		
C6113	TF C	ECQ-V50V-103J	1	374721034T		
C6115	TF C	ECQ-V50V-103J	1	374721034T		
C6706	UTSP C	CE04W50V-10M(UTSP)	1	397581007T		
C6901	ELECT C	CE69W56V-8200MB	1	3504416		<MDC, MDD, MDF, MPA, MPP>
C6901	ELECT C	CE69W63V-8200MB	1	3504420		<MMO, MMQ, MMR>

C6902	ELECT C	CE69W56V-8200MB	1	3504416		<MDC, MDD, MDF, MPA, MPP>
C6902	ELECT C	CE69W63V-8200MB	1	3504420		<MMO, MMQ, MMR>
C6911	C-CERA C	CC725CH1H-102J1	1	342101024R1		
C6912	TF C	ECQ-V50V-334J	1	374723344T		
C6913	TF C	ECQ-V50V-334J	1	374723344T		
C950	TF C	ECQ-V50V-104J	1	374721044T		
C960	VR C	CE04W63V-220M(VR)	1	394672217T		
C961	VR C	CE04W50V-47M(VR)	1	394684707T		
C962	C-CERA C	CK725F1E-104Z1	1	332161040R1		
[RESISTOR]						
R4000	C-CARBON R	RN72K1J-331JE	1			NSP
R4001	METAL O R	RS1WBJ-10	1	443621004T		<MMO, MMQ, MMR>
R4003	C-CARBON R	RN72K1J-331JE	1			NSP
R4004	C-CARBON R	RN72K1J-331JE	1			NSP
R4005	METAL O R	RS1WBJ-15	1	443621504T		<MMO, MMQ, MMR>
R4007	C-CARBON R	RN72K1J-331JE	1			NSP
R4008	C-CARBON R	RN72K1J-331JE	1			NSP
R4013	C-CARBON R	RN72K1J-331JE	1			NSP
R4014	C-CARBON R	RN72K1J-331JE	1			NSP
R4015	C-CARBON R	RN72K1J-222JE	1			NSP
R4016	C-CARBON R	RN72K1J-222JE	1			NSP
R4017	C-CARBON R	RN72K1J-331JE	1			NSP
R4018	C-CARBON R	RN72K1J-331JE	1			NSP
R4019	C-CARBON R	RN72K1J-331JE	1			NSP
R4020	C-CARBON R	RN72K1J-331JE	1			NSP
R4023	C-CARBON R	RN72K1J-000JE	1			NSP
R4027	C-CARBON R	RN72K1J-223JE	1			NSP
R4029	C-CARBON R	RN72K1J-101JE	1			NSP
R4043	C-CARBON R	RN72K1J-104JE	1			NSP
R4044	C-CARBON R	RN72K1J-104JE	1			NSP
R4047	C-CARBON R	RN72K1J-104JE	1			NSP
R4048	C-CARBON R	RN72K1J-104JE	1			NSP
R4053	C-CARBON R	RN72K1J-104JE	1			NSP
R4054	C-CARBON R	RN72K1J-104JE	1			NSP
R4055	C-CARBON R	RN72K1J-224JE	1			NSP
R4056	C-CARBON R	RN72K1J-224JE	1			NSP
R4057	C-CARBON R	RN72K1J-104JE	1			NSP
R4058	C-CARBON R	RN72K1J-104JE	1			NSP
R4059	C-CARBON R	RN72K1J-104JE	1			NSP
R4060	C-CARBON R	RN72K1J-104JE	1			NSP
R4067	C-CARBON R	RN72K1J-104JE	1			NSP

R4068	C-CARBON R	RN72K1J-104JE	1			NSP	
R4078	C-CARBON R	RN72K1J-473JE	1			NSP	
R4079	C-CARBON R	RN72K1J-473JE	1			NSP	
R4080	C-CARBON R	RN72K1J-104JE	1			NSP	
R4081	C-CARBON R	RN72K1J-104JE	1			NSP	
R4082	C-CARBON R	RN72K1J-104JE	1			NSP	
R4085	C-CARBON R	RN72K1J-182JE	1			NSP	
R4086	C-CARBON R	RN72K1J-182JE	1			NSP	
R4087	C-CARBON R	RN72K1J-103JE	1			NSP	
R4088	C-CARBON R	RN72K1J-103JE	1			NSP	
R4089	C-CARBON R	RN72K1J-000JE	1			NSP	
R4090	C-CARBON R	RN72K1J-123JE	1			NSP	
R4091	C-CARBON R	RN72K1J-223JE	1			NSP	
R4092	C-CARBON R	RN72K1J-331JE	1			NSP	
R4093	C-CARBON R	RN72K1J-332JE	1			NSP	
R4094	C-CARBON R	RN72K1J-103JE	1			NSP	
R4095	C-CARBON R	RN72K1J-103JE	1			NSP	
R4096	C-CARBON R	RN72K1J-331JE	1			NSP	
R4097	C-CARBON R	RN72K1J-332JE	1			NSP	
R4098	C-CARBON R	RN72K1J-123JE	1			NSP	
R4099	C-CARBON R	RN72K1J-223JE	1			NSP	
R4100	C-CARBON R	RN72K1J-224JE	1			NSP	
R4101	C-CARBON R	RN72K1J-224JE	1			NSP	
R4102	C-CARBON R	RN72K1J-224JE	1			NSP	
R4103	C-CARBON R	RN72K1J-224JE	1			NSP	
R4104	C-CARBON R	RN72K1J-224JE	1			NSP	
R4107	C-CARBON R	RN72K1J-224JE	1			NSP	<G MDF>, , <G MMR>
R4110	C-CARBON R	RN72K1J-222JE	1			NSP	
R4111	C-CARBON R	RN72K1J-222JE	1			NSP	
R4112	C-CARBON R	RN72K1J-222JE	1			NSP	
R4113	C-CARBON R	RN72K1J-222JE	1			NSP	
R4114	C-CARBON R	RN72K1J-222JE	1			NSP	
R4117	C-CARBON R	RN72K1J-271JE	1			NSP	
R4127	C-CARBON R	RN72K1J-101JE	1			NSP	
R4130	C-CARBON R	RN72K1J-221JE	1			NSP	
R4131	C-CARBON R	RN72K1J-473JE	1			NSP	
R4132	C-CARBON R	RN72K1J-153JE	1			NSP	
R4133	C-CARBON R	RN72K1J-122JE	1			NSP	
R4134	C-CARBON R	RN72K1J-103JE	1			NSP	
R4160	METAL R (!)	RNU1WCJ-0.22	1	453632294T			
R4161	METAL R (!)	RNU1WCJ-0.22	1	453632294T			

R4166	C-CARBON R	RN72K1J-220JE	1			NSP	
R4167	C-CARBON R	RN72K1J-220JE	1			NSP	
R4174	METAL O R	RS1WBJ-68	1	443626804T			
R4175	METAL O R	RS1WBJ-68	1	443626804T			
R4176	METAL O R	RS1WBJ-15	1	443621504T			<MMO, MMQ, MMR>
R4176	METAL O R	RS1WBJ-47	1	443624704T			<MDC, MDD, MDF, MPA, MPP>
R4177	METAL O R	RS1WBJ-15	1	443621504T			<MMO, MMQ, MMR>
R4177	METAL O R	RS1WBJ-47	1	443624704T			<MDC, MDD, MDF, MPA, MPP>
R4181	C-CARBON R	RN72K1J-224JE	1			NSP	
R4189	C-CARBON R	RN72K1J-224JE	1			NSP	
R4190	C-CARBON R	RN72K1J-224JE	1			NSP	
R4192	C-CARBON R	RN72K1J-224JE	1			NSP	
R4193	C-CARBON R	RN72K1J-224JE	1			NSP	
R4194	C-CARBON R	RN72K1J-224JE	1			NSP	
R4303	C-CARBON R	RN72K1J-512JE	1			NSP	
R4304	C-CARBON R	RN72K1J-512JE	1			NSP	
R6010	C-CARBON R	RN72K1J-102JE	1			NSP	
R6011	C-CARBON R	RN72K1J-102JE	1			NSP	
R6012	C-CARBON R	RN72K1J-102JE	1			NSP	
R6013	C-CARBON R	RN72K1J-102JE	1			NSP	
R6014	C-CARBON R	RN72K1J-102JE	1			NSP	
R6020	CARBON R	R16J-56K	1			NSP	
R6021	CARBON R	R16J-56K	1			NSP	
R6022	CARBON R	R16J-56K	1			NSP	
R6023	CARBON R	R16J-56K	1			NSP	
R6024	CARBON R	R16J-56K	1			NSP	
R6030	CARBON R	R16J-2.2K	1			NSP	
R6031	CARBON R	R16J-2.2K	1			NSP	
R6032	CARBON R	R16J-2.2K	1			NSP	
R6033	CARBON R	R16J-2.2K	1			NSP	
R6034	CARBON R	R16J-2.2K	1			NSP	
R6040	CARBON R	R16J-120K	1			NSP	
R6041	CARBON R	R16J-120K	1			NSP	
R6042	CARBON R	R16J-120K	1			NSP	
R6043	CARBON R	R16J-120K	1			NSP	
R6044	CARBON R	R16J-120K	1			NSP	
R6050	CARBON R	R16J-120K	1			NSP	
R6051	CARBON R	R16J-120K	1			NSP	
R6052	CARBON R	R16J-120K	1			NSP	
R6053	CARBON R	R16J-120K	1			NSP	
R6054	CARBON R	R16J-120K	1			NSP	

R6060	METAL PR	MPR2W+2W 0R22	1	4000234		
R6061	METAL PR	MPR2W+2W 0R22	1	4000234		
R6062	METAL PR	MPR2W+2W 0R22	1	4000234		
R6063	METAL PR	MPR2W+2W 0R22	1	4000234		
R6064	METAL PR	MPR2W+2W 0R22	1	4000234		
R6070	C-CARBON R	RN72K1J-563JE	1			NSP
R6071	C-CARBON R	RN72K1J-563JE	1			NSP
R6072	C-CARBON R	RN72K1J-563JE	1			NSP
R6073	C-CARBON R	RN72K1J-563JE	1			NSP
R6074	C-CARBON R	RN72K1J-563JE	1			NSP
R6080	C-CARBON R	RN72K1J-123JE	1			NSP
R6081	C-CARBON R	RN72K1J-123JE	1			NSP
R6082	C-CARBON R	RN72K1J-123JE	1			NSP
R6083	C-CARBON R	RN72K1J-123JE	1			NSP
R6084	C-CARBON R	RN72K1J-123JE	1			NSP
R6100	C-CARBON R	RN72K1J-333JE	1			NSP
R6101	C-CARBON R	RN72K1J-333JE	1			NSP
R6102	C-CARBON R	RN72K1J-333JE	1			NSP
R6103	C-CARBON R	RN72K1J-333JE	1			NSP
R6104	C-CARBON R	RN72K1J-333JE	1			NSP
R6110	C-CARBON R	RN72K1J-473JE	1			NSP
R6111	C-CARBON R	RN72K1J-473JE	1			NSP
R6112	C-CARBON R	RN72K1J-473JE	1			NSP
R6113	C-CARBON R	RN72K1J-473JE	1			NSP
R6114	C-CARBON R	RN72K1J-473JE	1			NSP
R6120	C-CARBON R	RN72K1J-473JE	1			NSP
R6121	C-CARBON R	RN72K1J-473JE	1			NSP
R6122	C-CARBON R	RN72K1J-473JE	1			NSP
R6123	C-CARBON R	RN72K1J-473JE	1			NSP
R6124	C-CARBON R	RN72K1J-473JE	1			NSP
R6130	C-CARBON R	RN72K2E-150JE	1			NSP
R6131	C-CARBON R	RN72K2E-150JE	1			NSP
R6132	C-CARBON R	RN72K2E-150JE	1			NSP
R6133	C-CARBON R	RN72K2E-150JE	1			NSP
R6134	C-CARBON R	RN72K2E-150JE	1			NSP
R6140	METAL R	RNU1WCJ-8.2	1	453630824T		
R6141	METAL R	RNU1WCJ-8.2	1	453630824T		
R6142	METAL R	RNU1WCJ-8.2	1	453630824T		
R6143	METAL R	RNU1WCJ-8.2	1	453630824T		
R6144	METAL R	RNU1WCJ-8.2	1	453630824T		
R6203	CARBON R	R16J-33K	1			NSP

R6204	METAL O R	RS1WBJ-100	1	441621014F		
R6205	METAL O R	RS1WBJ-100	1	441621014F		
R6208	CARBON R	R16J-33K	1			NSP
R6209	METAL O R	RS1WBJ-100	1	441621014F		
R6210	METAL O R	RS1WBJ-100	1	441621014F		
R6211	C-CARBON R	RN72K1J-333JE	1			NSP
R6213	C-CARBON R	RN72K1J-103JE	1			NSP
R6214	C-CARBON R	RN72K1J-473JE	1			NSP
R6216	C-CARBON R	RN72K1J-224JE	1			NSP
R6217	C-CARBON R	RN72K1J-473JE	1			NSP
R6218	C-CARBON R	RN72K1J-103JE	1			NSP
R6219	C-CARBON R	RN72K1J-224JE	1			NSP
R6230	C-CARBON R	RN72K2E-150JE	1			NSP
R6231	C-CARBON R	RN72K2E-150JE	1			NSP
R6232	C-CARBON R	RN72K2E-150JE	1			NSP
R6233	C-CARBON R	RN72K2E-150JE	1			NSP
R6234	C-CARBON R	RN72K2E-150JE	1			NSP
R6251	METAL O R	RS1/2WBJ-390	1	443523914T		
R6252	METAL O R	RS1/2WBJ-390	1	443523914T		
R6302	METAL O R	RS1WBJ-33	1	443623304T		
R6303	METAL O R	RS1WBJ-470	1	443624714T		
R6304	METAL O R	RS1WBJ-470	1	443624714T		
R6305	METAL O R	RS1WBJ-470	1	443624714T		
R6306	METAL O R	RS1WBJ-470	1	443624714T		
R6307	METAL O R	RS1WBJ-470	1	443624714T		
R6308	METAL O R	RS1WBJ-470	1	443624714T		
R6309	METAL O R	RS1WBJ-470	1	443624714T		
R6310	METAL O R	RS1WBJ-470	1	443624714T		
R6322	METAL O R	RS1WBJ-47	1	443624704T		
R6709	C-CARBON R	RN72K1J-562JE	1			NSP
R6710	C-CARBON R	RN72K1J-562JE	1			NSP
R6902	C-CARBON R	RN72K1J-102JE	1			NSP
R6903	C-CARBON R	RN72K1J-473JE	1			NSP
R6912	C-CARBON R	RN72K1J-000JE	1			NSP
R950	METAL O R	RSWBJ-10	1	443621004T		
R960	METAL R	RNU1/2WCJ-8.2	1	453530824T		
R961	METAL O R	RUN1/2WBJ-3.3	1	453530334T		
R962	C-CARBON R	RN72K1J-822JE	1			NSP
R963	C-CARBON R	RN72K1J-822JE	1			NSP
R964	C-CARBON R	RN72K1J-333JE	1			NSP

[SW TRM]

E6001	RETAINER	MET37-0002	1	27142009T			
F6901A	FUSE HOL	NSCT-1P2031	1	25052133T			
F6901B	FUSE HOL	NSCT-1P2031	1	25052133T			
F6902A	FUSE HOL	NSCT-1P2031	1	25052133T			
F6902B	FUSE HOL	NSCT-1P2031	1	25052133T			
JL501A	WIRE HOL	NSCT-3P874	1	25051087			
JL502A	WIRE HOL	NSCT-5P876	1	25051089			
JL600A	WIRE HOL	NSCT-7P898	1	25051111			
JL600B	WIRE HOL	NSCT-7P898	1	25051111			
JL603A	WIRE HOL	NSCT-9P900	1	25051113			
JL603B	WIRE HOL	NSCT-9P900	1	25051113			
JL605B	SOCKET	NSCT-5P97	1	25050269			
JL951A	WIRE HOL	NSCT-5P896	1	25051109			
JL951B	SOCKET	NSCT-5P97	1	25050269			
JL952A	WIRE HOL	NSCT-3P894	1	25051107			
JL953B	WIRE TRAP	NPLG-5P588	1	25055626			
JL954A	WIRE HOL	NSCT-9P900	1	25051113			
JL954B	WIRE HOL	NSCT-9P900	1	25051113			
P4000	ST JACK	MSJ-035-22	1	25045887			
P4000 or	JACK	YKB21-5130	(1)	25045387			
P4002	PIN JACK	NPJ-2PDWR595	1	25045815			
P4003	PIN JACK	NPJ-2PDWR558	1	25045776			
P4003 or	PIN JACK	NPJ-2PDBL185	(1)	25045333			
P4005	PIN JACK	NPJ-4PDWWRR624	1	25045845			
P4005 or	PIN JACK	NPJ-4PDBL162	(1)	25045303			
P4006	PIN JACK	NPJ-4PDWWRR624	1	25045845			
P4006 or	PIN JACK	NPJ-4PDBL162	(1)	25045303			
P4009	PIN JACK	NPJ-1PDP555	1	25045773			
P5501B	PLUG	NPLG-7P0962	1	25056012			
P5502B	PLUG	NPLG-15P0970	1	25056020			
P5503B	PLUG	NPLG-9P0964	1	25056014			
P5504B	PLUG	NPLG-7P0962	1	25056012			
P6001	TRM	NTM-10PDML363	1	25060434			
P6001 or	TRM	NTM-10PDML354	(1)	25060425			
P6002	TRM	NTM-4PDMNRR420	1	25060492			
P6900	CRIMP AS	CRIMP AS	1	20799162UL			
P6901	CRIMP AS	CRIMP AS	1	2069925162UL			
P6902	CRIMP AS	CRIMP AS	1	2069925149UL			
P6903	WS CLAMP	CB-71683(L=50)	1	260261			
P6906	WS CLAMP	CB-71683(L=50)	1	260261			
P6909	WS CLAMP	CB-71683(L=50)	1	260261			

P6913	WS CLAMP	CB-71683(L=50)	1	260261			
RL601	RELAY	NRL-2P5A-DC12-192	1	25065702			
RL602	RELAY	NRL-2P5A-DC12-192	1	25065702			
RL603	RELAY	NRL-2P5A-DC12-192	1	25065702			
RL605	RELAY	NRL-2P5A-DC12-192	1	25065702			
RL691	RELAY	NRL-1P10A-DC12-196	1	25065707			
RL691 or	RELAY	NRL-1P10A-DC12-197	(1)	25065708			
RL691 or	RELAY	NRL-1P10A-DC12-198	(1)	25065709			
RL692	RELAY	NRL-1P10A-DC12-196	1	25065707			
RL692 or	RELAY	NRL-1P10A-DC12-197	(1)	25065708			
RL692 or	RELAY	NRL-1P10A-DC12-198	(1)	25065709			
[CHASSIS SCREW]							
Q4170A	HEAT-SINK	HEAT-SINK(RAD-68)	1			NSP	
Q4170B	SCREW	3P+10FN(3BC)	1			NSP	
Q4171A	HEAT-SINK	HEAT-SINK(RAD-68)	1			NSP	
Q4171B	SCREW	3P+10FN(3BC)	1			NSP	

				TX-SR308			
PC BOARD PARTS LIST							

U003	DG-AS (MPU/DAC ASSY) (U0030/31)	BADG-0364-1A *	1	1B247564-1A	N	<MDC, MDD, MDF>
U003	DG-AS (MPU/DAC ASSY) (U0030/31)	BADG-0364-1B *	1	1B247564-1B	N	<MMO, MMQ, MPA, MPP, MMR>
U0030	DG-AS (MPU/DAC)	BADG-0364-1A	1	1B2475364-1A	N	<MDC, MDD, MDF>
U0030	DG-AS (MPU/DAC)	BADG-0364-1B	1	1B2475364-1B	N	<MMO, MMQ, MPA, MPP, MMR>
U0031	PWB (U-PORT)	BAETC-0365-1A	1	1B2475365-1A	N	<MDC, MDD, MDF>
U0031	PWB (U-PORT)	BAETC-0365-1B	1	1B2475365-1B	N	<MMO, MMQ, MPA, MPP, MMR>

CIRCUIT. N	PART NAME	DESCRIPTION	Q'TY	PART NO. (SN)	REMARKS
-------------------	------------------	--------------------	-------------	----------------------	----------------

[TUNER UNIT]							
U131	PHT CP	JSR1165-001recieving	1	24120143			
U132	PHT CP	JSR1165-001recieving	1	24120143			

[SEMI CONDUCTOR]							
-------------------------	--	--	--	--	--	--	--

D110	C-DIODE	KDS4148U	1			NSP	
D110 or	C-DIODE	1SS352	(1)			NSP	
D110 or	C-DIODE	MA2J111	(1)			NSP	
D111	C-DIODE	KDS4148U	1			NSP	
D111 or	C-DIODE	1SS352	(1)			NSP	
D111 or	C-DIODE	MA2J111	(1)			NSP	
D112	ZENER D	UDZS10B	1	224551000R2			
D131	C-DIODE	KDS4148U	1			NSP	

D131 or	C-DIODE	1SS352	(1)			NSP	
D131 or	C-DIODE	MA2J111	(1)			NSP	
D132	C-DIODE	KDS4148U	1			NSP	
D132 or	C-DIODE	1SS352	(1)			NSP	
D132 or	C-DIODE	MA2J111	(1)			NSP	
D182	DIODE	RL1N4003	1	22380260T			
D183	DIODE	RL1N4003	1	22380260T			
D601	C-DIODE	KDS4148U	1			NSP	
D601 or	C-DIODE	1SS352	(1)			NSP	
D601 or	C-DIODE	MA2J111	(1)			NSP	
D701	C-DIODE	KDS4148U	1			NSP	
D701 or	C-DIODE	1SS352	(1)			NSP	
D701 or	C-DIODE	MA2J111	(1)			NSP	
D702	C-DIODE	KDS4148U	1			NSP	
D702 or	C-DIODE	1SS352	(1)			NSP	
D702 or	C-DIODE	MA2J111	(1)			NSP	
Q101	IC	LC72725KV-TLM-E	1	22242584R2			<MMO, MMQ,MPA,MPP, MMR>
Q111	TR	2SC2235-Y(TPE6_F)	1	2211654T			
Q131	IC	TC74HCU04AF	1	222740046R2TO			
Q131 or	IC	74HCU04F	(1)	222740046R2			
Q153	IC	R1EX25064ASA00A	1	22242581R2			
Q153 or	IC	M95640-WMN6TP	(1)	22242643R2		N	
Q181	TR	KRC105S	1	2217290R2			
Q181 or	TR	RN1405	(1)	2214500R2			
Q2804	IC	NJM4580M-D	1	22241448R2			
Q301	IC	PCM9210PTR	1	22242629R2		N	
Q302	IC	PCM1690DCAR	1	22242599R2			
Q401	IC	NJM4580M-D	1	22241448R2			
Q402	IC	NJM4580M-D	1	22241448R2			
Q403	IC	NJM4580M-D	1	22241448R2			
Q405	IC	NJM4580M-D	1	22241448R2			
Q601	TR	KRC104S	1	2216210R2			
Q601 or	TR	RN1404	(1)	2214490R2			
Q701	IC (MMPU)	MPD70F3746GJ-GAE-AX(0345)	1	222W0079R303450			
Q702	IC	S-812C33AUA-C2N	1	22242222R2			
Q703	IC	S-812C56AUA-C3K	1	22242207R2			
Q704	IC	SN74CB3Q3305PWR	1	22242258R2			
Q746	IC	XC6221B332MR	1	22242633R2			
Q751	TR	KRC104S	1	2216210R2			
Q751 or	TR	RN1404	(1)	2214490R2			
Q752	TR	KRA102S	1	2216220R2			

Q752 or	TR	RN2402	(1)	2214530R2			
Q753	TR	KRA107S	1	2216350R2			
Q753 or	TR	RN2407(TE85L_F)	(1)	2216360R2			
Q754	TR	KRC102S	1	2216190R2			
Q754 or	TR	RN1402	(1)	2214470R2			
Q755	TR	KRA107S	1	2216350R2			
Q755 or	TR	RN2407(TE85L_F)	(1)	2216360R2			
Q756	TR	KRC102S	1	2216190R2			
Q756 or	TR	RN1402	(1)	2214470R2			
Q757	TR	KRC107S	1	2216340R2			
Q757 or	TR	RN1407	(1)	2216260R2			
Q771	TR	KRC104S	1	2216210R2			
Q771 or	TR	RN1404	(1)	2214490R2			
Q772	TR	KRA102S	1	2216220R2			
Q772 or	TR	RN2402	(1)	2214530R2			
[TRANS COIL]							
L101	CORE	BLM18PG181SN1D	1	2350005R1			<MMO, MMQ, MPA, MPP, MMR>
L131	CHOKE COIL	LBC2518T2R2M	1	231364M022R2			
L133	CHOKE COIL	LBC2518T470M	1	231364M470R2			
L134	CHOKE COIL	LBC2518T470M	1	231364M470R2			
L135	C-CARBON R	RN72K1J-000JE	1	435030004R1			
L153	CORE	BLM18PG181SN1D	1	2350005R1			
L2800	CORE	BLM18PG181SN1D	1	2350005R1			
L2801	CORE	BLM18PG181SN1D	1	2350005R1			
L2802	CORE	BLM18PG181SN1D	1	2350005R1			
L2803	EMIFIL	BK1608LM182-T	1	230958R1			
L2804	EMIFIL	BK1608LM182-T	1	230958R1			
L2805	EMIFIL	BK1608LM182-T	1	230958R1			
L2806	EMIFIL	BK1608LM182-T	1	230958R1			
L2807	EMIFIL	BK1608LM182-T	1	230958R1			
L2808	EMIFIL	BK1608LM182-T	1	230958R1			
L2809	EMIFIL	BK1608LM182-T	1	230958R1			
L2810	EMIFIL	BK1608LM182-T	1	230958R1			
L2811	EMIFIL	BK1608LM182-T	1	230958R1			
L2812	EMIFIL	BK1608LM182-T	1	230958R1			
L2813	EMIFIL	BK1608LM182-T	1	230958R1			
L2814	EMIFIL	BK1608LM182-T	1	230958R1			
L2815	EMIFIL	BK1608LM182-T	1	230958R1			
L2816	EMIFIL	BK1608LM182-T	1	230958R1			
L2817	EMIFIL	BK1608LM182-T	1	230958R1			
L2818	EMIFIL	BK1608LM182-T	1	230958R1			

L301	EMIFIL	BK1608LM182-T	1	230958R1			
L302	EMIFIL	BK1608LM182-T	1	230958R1			
L303	CHOKE COIL	LBC2518T4R7M	1	231364M047R2			
L304	CHOKE COIL	LBC2518T4R7M	1	231364M047R2			
L305	CHOKE COIL	LBC2518T4R7M	1	231364M047R2			
L307	C-CARBON R	RN72K1J-000JE	1	435030004R1			
L401	CHOKE COIL	LBC2518T4R7M	1	231364M047R2			
L402	CHOKE COIL	LBC2518T4R7M	1	231364M047R2			
L500	CORE	BLM18PG181SN1D	1	2350005R1			
L742	CHOKE COIL	BLM21PG221SN1	1	230949R2			
L743	CORE	BLM18PG181SN1D	1	2350005R1			
L744	CORE	BLM18PG181SN1D	1	2350005R1			
L746	CORE	BLM18PG181SN1D	1	2350005R1			
L747	CORE	BLM18PG181SN1D	1	2350005R1			
X101	CRYSTAL	HC-49S 4.332MHz	1	3010469T			<MMO, MMQ, MPA, MPP, MMR>
X171	CRYSTAL	HC-49US24.576MHz	1	3010490T	N		
X171A	CUSHION	(BUTYL)	1	28141748			
X501	CERA LOCK	CSTCR5M00G53-B0	1	3010356R2			
[CAPACITOR]							
C102	C-CERA C	CK725F1E-104Z1	1			NSP	
C103	UTSP C	CE04W50V-10M(UTSP)	1	397581007T			<MMO, MMQ, MPA, MPP, MMR>
C104	UTSP C	CE04W50V-10M(UTSP)	1	397581007T			<MMO, MMQ, MPA, MPP, MMR>
C105	C-CERA C	CK725F1E-104Z1	1			NSP	<MMO, MMQ, MPA, MPP, MMR>
C106	C-CERA C	CC725CH1H-331J1	1			NSP	<MMO, MMQ, MPA, MPP, MMR>
C107	C-CERA C	CK725F1E-104Z1	1			NSP	<MMO, MMQ, MPA, MPP, MMR>
C108	C-CERA C	CC725CH1H-150J1	1			NSP	<MMO, MMQ, MPA, MPP, MMR>
C109	C-CERA C	CC725CH1H-150J1	1			NSP	<MMO, MMQ, MPA, MPP, MMR>
C110	C-CERA C	CC725CH1H-331J1	1			NSP	<MMO, MMQ, MPA, MPP, MMR>
C111	UTSP C	CE04W25V-47M(UTSP)	1	397554707T			
C112	C-CERA C	CK725F1E-104Z1	1	332161040R1			
C113	C-CERA C	CC725CH1H-221J1	1			NSP	<MMO, MMQ, MPA, MPP, MMR>
C114	UTSP C	CE04W25V-47M(UTSP)	1			NSP	
C130	C-CERA C	CK725F1E-104Z1	1	332161040R1			
C131	C-CERA C	CC725CH1H-101J1	1			NSP	
C133	C-CERA C	CK725B1C-104K1	1			NSP	
C135	C-CERA C	CC725CH1H-080D1	1			NSP	
C139	UTSP C	CE04W10V-220M(UTSP)	1			NSP	
C140	C-CERA C	CK725F1E-104Z1	1	332161040R1			
C141	C-CERA C	CK725F1E-104Z1	1			NSP	
C142	C-CERA C	CK725F1E-104Z1	1			NSP	
C143	C-CERA C	CC725CH1H-330J1	1			NSP	

C144	C-CERA C	CC725CH1H-330J1	1			NSP
C145	UTSP C	GE04W10V-220M(UTSP)	1	397532217T		
C151	C-CERA C	CK725F1E-104Z1	1			NSP
C172	C-CERA C	CC725CH1H-180J1	1			NSP
C173	C-CERA C	CC725CH1H-180J1	1			NSP
C2850	C-CERA C	CC725CH1H-471J1	1			NSP
C2851	C-CERA C	CC725CH1H-471J1	1			NSP
C2852	C-CERA C	CC725CH1H-470J1	1			NSP
C2855	C-CERA C	CK725F1E-104Z1	1			NSP
C2870	C-CERA C	CC725CH1H-101J1	1			NSP
C2871	C-CERA C	CC725CH1H-101J1	1			NSP
C2877	UTSP C	GE04W50V-10M(UTSP)	1	397581007T		
C2878	UTSP C	GE04W50V-10M(UTSP)	1	397581007T		
C2880	C-CERA C	CC725CH1H-101J1	1			NSP
C2881	C-CERA C	CC725CH1H-101J1	1			NSP
C2882	C-CERA C	CC725CH1H-101J1	1			NSP
C2883	C-CERA C	CC725CH1H-101J1	1			NSP
C2884	C-CERA C	CK732B1A-105K	1			NSP
C2885	C-CERA C	CK732B1A-105K	1			NSP
C2886	C-CERA C	CC725CH1H-471J1	1			NSP
C2887	C-CERA C	CC725CH1H-471J1	1			NSP
C2888	C-CERA C	CK725F1E-104Z1	1			NSP
C2889	C-CERA C	CK725F1E-104Z1	1			NSP
C2891	C-CERA C	CK732B1A-105K	1			NSP
C2892	C-CERA C	CK732B1A-105K	1			NSP
C2893	C-CERA C	CC725CH1H-471J1	1			NSP
C2894	C-CERA C	CC725CH1H-471J1	1			NSP
C2895	C-CERA C	CC725CH1H-471J1	1			NSP
C2896	C-CERA C	CC725CH1H-471J1	1			NSP
C2897	C-CERA C	CK732B1A-105K	1			NSP
C2898	C-CERA C	CK732B1A-105K	1			NSP
C305	C-CERA C	CK725F1E-104Z1	1			NSP
C306	UTSP C	GE04W10V-470M(UTSP)	1	397534717T		
C307	C-CERA C	CK725F1E-104Z1	1			NSP
C312	C-CERA C	CC725CH1H-221J1	1			NSP
C313	C-CERA C	CK725F1E-104Z1	1			NSP
C314	UTSP C	GE04W10V-470M(UTSP)	1	397534717T		
C315	C-CERA C	CK725B1H-472K1	1			NSP
C316	C-CERA C	CK725B1H-473K1	1			NSP
C317	C-CERA C	CK725F1E-104Z1	1			NSP
C318	UTSP C	GE04W10V-470M(UTSP)	1	397534717T		

C319	UTSP C	CE04W25V-47M(UTSP)	1	397554707T		
C320	C-CERA C	CK725B1H-223K1	1		NSP	
C351	UTSP C	CE04W10V-470M(UTSP)	1	397534717T		
C352	C-CERA C	CK725F1E-104Z1	1		NSP	
C353	UTSP C	CE04W10V-470M(UTSP)	1	397534717T		
C354	C-CERA C	CK725F1E-104Z1	1		NSP	
C355	C-CERA C	CK725F1E-104Z1	1		NSP	
C356	UTSP C	CE04W25V-47M(UTSP)	1	397554707T		
C357	C-CERA C	CK725F1E-104Z1	1		NSP	
C400	UPZ C	2AUPZTF471JE	1	376334714T		
C401	UPZ C	2AUPZTF471JE	1	376334714T		
C402	UPZ C	2AUPZTF471JE	1	376334714T		
C403	UPZ C	2AUPZTF471JE	1	376334714T		
C404	UPZ C	2AUPZTF471JE	1	376334714T		
C407	UPZ C	2AUPZTF471JE	1	376334714T		
C410	UPZ C	2AUPZTF101JE	1	376331014T		
C411	UPZ C	2AUPZTF101JE	1	376331014T		
C412	UPZ C	2AUPZTF101JE	1	376331014T		
C413	C-CERA C	CC725CH1H-101J1	1		NSP	
C414	C-CERA C	CC725CH1H-101J1	1		NSP	
C417	UPZ C	2AUPZTF101JE	1	376331014T		
C420	UPZ C	2AUPZTF101JE	1	376331014T		
C421	UPZ C	2AUPZTF101JE	1	376331014T		
C422	UPZ C	2AUPZTF101JE	1	376331014T		
C423	C-CERA C	CC725CH1H-101J1	1		NSP	
C424	C-CERA C	CC725CH1H-101J1	1		NSP	
C427	UPZ C	2AUPZTF101JE	1	376331014T		
C470	UTSP C	CE04W50V-10M(UTSP)	1	397581007T		
C471	UTSP C	CE04W50V-10M(UTSP)	1	397581007T		
C498	UTSP C	CE04W50V-10M(UTSP)	1	397581007T		
C499	UTSP C	CE04W50V-10M(UTSP)	1	397581007T		
C501	UTSP C	CE04W50V-4.7M(UTSP)	1	397580477T		
C502	C-CERA C	CK725F1E-104Z1	1		NSP	
C503	C-CERA C	CK725F1E-104Z1	1		NSP	
C504	C-CERA C	CK725F1E-104Z1	1		NSP	
C505	C-CERA C	CK725F1E-104Z1	1		NSP	
C507	C-CERA C	CK725F1E-104Z1	1		NSP	
C508	C-CERA C	CK725F1E-104Z1	1		NSP	
C509	C-CERA C	CK725B0J-106K	1		NSP	
C511	C-CERA C	CK725B1H-102K1	1		NSP	
C512	C-CERA C	CK725B1H-102K1	1		NSP	

C513	C-CERA C	CC725CH1H-101J1	1		NSP	
C514	C-CERA C	CC725CH1H-101J1	1		NSP	
C515	C-CERA C	CC725CH1H-101J1	1		NSP	
C516	C-CERA C	CC725CH1H-101J1	1		NSP	
C517	C-CERA C	CK725F1E-104Z1	1		NSP	
C518	C-CERA C	CK725B1H-102K1	1		NSP	
C519	C-CERA C	CK725B1H-102K1	1		NSP	
C520	C-CERA C	CK725B1H-102K1	1		NSP	
C521	C-CERA C	CK725B1H-102K1	1		NSP	
C522	C-CERA C	CK725F1E-104Z1	1		NSP	
C523	C-CERA C	CK725B1H-102K1	1		NSP	
C524	C-CERA C	CK725B1H-102K1	1		NSP	
C525	C-CERA C	CK725F1E-104Z1	1		NSP	
C526	C-CERA C	CK725B1H-102K1	1		NSP	
C527	C-CERA C	CK725B1H-102K1	1		NSP	
C528	C-CERA C	CK725F1E-104Z1	1		NSP	
C551	C-CERA C	CK725F1E-104Z1	1		NSP	
C552	C-CERA C	CK725F1E-104Z1	1		NSP	
C613	C-CERA C	CK732B1C-474K	1		NSP	
C629	C-CERA C	CK725F1E-104Z1	1		NSP	
C701	C-CERA C	CK725F1E-104Z1	1		NSP	
C705	C-CERA C	CK725B0J-106K	1		NSP	
C706	UTSP C	CE04W16V-470M(UTSP)	1	397544717T		
C707	UTSP C	CE04W10V-100M(UTSP)	1	397531017T		
C708	UTSP C	CE04W10V-470M(UTSP)	1	397534717T		
C709	C-CERA C	CK725F1E-104Z1	1		NSP	
C710	C-CERA C	CK725F1E-104Z1	1		NSP	
C744	C-CERA C	CK725F1E-104Z1	1		NSP	
C745	C-CERA C	CK725B0J-106K	1		NSP	
C748	UTSP C	CE04W10V-100M(UTSP)	1	397531017T		
C751	UTSP C	CE04W50V-0.47M(UTSP)	1	397584797T		
C753	UTSP C	CE04W10V-470M(UTSP)	1	397534717T		
C771	UTSP C	CE04W50V-0.47M(UTSP)	1	397584797T		
C772	C-CERA C	CK732B1C-474K	1		NSP	
C800	C-CERA C	CK725F1E-104Z1	1		NSP	
C801	C-CERA C	CK725B1H-103K1	1		NSP	
C802	C-CERA C	CK725F1E-104Z1	1		NSP	
[RESISTOR]						
R107	C-CARBON R	RN72K1J-101JE	1		NSP	<MMO, MMQ, MPA, MPP, MMR>
R108	C-CARBON R	RN72K1J-101JE	1		NSP	<MMO, MMQ, MPA, MPP, MMR>
R110	C-CARBON R	RN72K1J-103JE	1		NSP	

R112	METAL O R	RS1WBJ-22	1	443622204T		
R113	C-CARBON R	RN72K1J-221JE	1			NSP
R114	C-CARBON R	RN72K1J-221JE	1			NSP
R115	C-CARBON R	RN72K1J-333JE	1			NSP
R131	C-CARBON R	RN72K1J-750JE	1			NSP
R133	C-CARBON R	RN72K1J-100JE	1			NSP
R137	C-CARBON R	RN72K1J-103JE	1			NSP
R139	C-CARBON R	RN72K1J-823JE	1			NSP
R141	C-CARBON R	RN72K1J-470JE	1			NSP
R142	C-CARBON R	RN72K1J-470JE	1			NSP
R151	C-CARBON R	RN72K1J-103JE	1			NSP
R152	C-CARBON R	RN72K1J-103JE	1			NSP
R153	C-CARBON R	RN72K1J-222JE	1			NSP
R154	C-CARBON R	RN72K1J-103JE	1			NSP
R181	METAL R	RNU1/2WCJ-4.7	1	453530474T		
R182	METAL R	RNU1/2WCJ-1	1	453530104T		
R2800	THERMISTOR	FUSB090F	1	4000252T		
R2804	C-CARBON R	RN72K1J-123JE	1			NSP
R2805	C-CARBON R	RN72K1J-123JE	1			NSP
R2806	C-CARBON R	RN72K1J-223JE	1			NSP
R2807	C-CARBON R	RN72K1J-223JE	1			NSP
R2808	C-CARBON R	RN72K1J-123JE	1			NSP
R2809	C-CARBON R	RN72K1J-123JE	1			NSP
R2810	C-CARBON R	RN72K1J-223JE	1			NSP
R2811	C-CARBON R	RN72K1J-223JE	1			NSP
R2820	C-CARBON R	RN72K1J-471JE	1			NSP
R2821	C-CARBON R	RN72K1J-471JE	1			NSP
R2830	C-CARBON R	RN72K1J-105JE	1			NSP
R2848	C-CARBON R	RN72K1J-000JE	1			NSP
R2849	C-CARBON R	RN72K1J-000JE	1			NSP
R2852	C-CARBON R	RN72K1J-750JE	1			NSP
R2861	C-CARBON R	RN72K1J-103JE	1			NSP
R2862	C-CARBON R	RN72K1J-103JE	1			NSP
R2863	C-CARBON R	RN72K1J-103JE	1			NSP
R2864	C-CARBON R	RN72K1J-103JE	1			NSP
R301	C-CARBON R	RN72K1J-470JE	1			NSP
R302	C-CARBON R	RN72K1J-000JE	1			NSP
R304	C-CARBON R	RN72K1J-221JE	1			NSP
R305	C-CARBON R	RN72K1J-221JE	1			NSP
R306	C-CARBON R	RN72K1J-330JE	1			NSP
R307	C-CARBON R	RN72K1J-331JE	1			NSP

R308	C-CARBON R	RN72K1J-331JE	1		NSP
R312	C-CARBON R	RN72K1J-470JE	1		NSP
R313	C-CARBON R	RN72K1J-470JE	1		NSP
R314	C-CARBON R	RN72K1J-151JE	1		NSP
R315	C-CARBON R	RN72K1J-151JE	1		NSP
R316	C-CARBON R	RN72K1J-470JE	1		NSP
R317	C-CARBON R	RN72K1J-331JE	1		NSP
R321	C-CARBON R	RN72K1J-331JE	1		NSP
R322	C-CARBON R	RN72K1J-331JE	1		NSP
R324	C-CARBON R	RN72K1J-331JE	1		NSP
R325	C-CARBON R	RN72K1J-331JE	1		NSP
R326	C-CARBON R	RN72K1J-331JE	1		NSP
R327	C-CARBON R	RN72K1J-221JE	1		NSP
R331	C-CARBON R	RN72K1J-221JE	1		NSP
R332	C-CARBON R	RN72K1J-681JE	1		NSP
R333	C-CARBON R	RN72K1J-221JE	1		NSP
R341	C-CARBON R	RN72K1J-000JE	1		NSP
R350	C-CARBON R	RN72K1J-331JE	1		NSP
R351	C-CARBON R	RN72K1J-331JE	1		NSP
R352	C-CARBON R	RN72K1J-331JE	1		NSP
R354	C-CARBON R	RN72K1J-221JE	1		NSP
R355	C-CARBON R	RN72K1J-220JE	1		NSP
R356	C-CARBON R	RN72K1J-220JE	1		NSP
R357	C-CARBON R	RN72K1J-220JE	1		NSP
R358	C-CARBON R	RN72K1J-220JE	1		NSP
R359	C-CARBON R	RN72K1J-220JE	1		NSP
R360	C-CARBON R	RN72K1J-220JE	1		NSP
R361	C-CARBON R	RN72K1J-331JE	1		NSP
R362	C-CARBON R	RN72K1J-472JE	1		NSP
R371	C-CARBON R	RN72K1J-102JE	1		NSP
R400	C-CARBON R	RN72K1J-153JE	1		NSP
R401	C-CARBON R	RN72K1J-153JE	1		NSP
R402	C-CARBON R	RN72K1J-153JE	1		NSP
R403	C-CARBON R	RN72K1J-153JE	1		NSP
R404	C-CARBON R	RN72K1J-153JE	1		NSP
R407	C-CARBON R	RN72K1J-153JE	1		NSP
R410	C-CARBON R	RN72K1J-153JE	1		NSP
R411	C-CARBON R	RN72K1J-153JE	1		NSP
R412	C-CARBON R	RN72K1J-153JE	1		NSP
R413	C-CARBON R	RN72K1J-153JE	1		NSP
R414	C-CARBON R	RN72K1J-153JE	1		NSP

R417	C-CARBON R	RN72K1J-153JE	1		NSP
R420	C-CARBON R	RN72K1J-103JE	1		NSP
R421	C-CARBON R	RN72K1J-103JE	1		NSP
R430	C-CARBON R	RN72K1J-103JE	1		NSP
R431	C-CARBON R	RN72K1J-103JE	1		NSP
R440	C-CARBON R	RN72K1J-123JE	1		NSP
R441	C-CARBON R	RN72K1J-123JE	1		NSP
R442	C-CARBON R	RN72K1J-223JE	1		NSP
R443	C-CARBON R	RN72K1J-223JE	1		NSP
R444	C-CARBON R	RN72K1J-223JE	1		NSP
R447	C-CARBON R	RN72K1J-223JE	1		NSP
R450	C-CARBON R	RN72K1J-123JE	1		NSP
R451	C-CARBON R	RN72K1J-123JE	1		NSP
R452	C-CARBON R	RN72K1J-223JE	1		NSP
R453	C-CARBON R	RN72K1J-223JE	1		NSP
R454	C-CARBON R	RN72K1J-223JE	1		NSP
R457	C-CARBON R	RN72K1J-223JE	1		NSP
R460	C-CARBON R	RN72K1J-182JE	1		NSP
R461	C-CARBON R	RN72K1J-182JE	1		NSP
R462	C-CARBON R	RN72K1J-182JE	1		NSP
R463	C-CARBON R	RN72K1J-182JE	1		NSP
R464	C-CARBON R	RN72K1J-182JE	1		NSP
R467	C-CARBON R	RN72K1J-182JE	1		NSP
R470	C-CARBON R	RN72K1J-182JE	1		NSP
R471	C-CARBON R	RN72K1J-182JE	1		NSP
R472	C-CARBON R	RN72K1J-182JE	1		NSP
R473	C-CARBON R	RN72K1J-182JE	1		NSP
R474	C-CARBON R	RN72K1J-182JE	1		NSP
R477	C-CARBON R	RN72K1J-182JE	1		NSP
R480	C-CARBON R	RN72K1J-273JE	1		NSP
R481	C-CARBON R	RN72K1J-273JE	1		NSP
R482	C-CARBON R	RN72K1J-223JE	1		NSP
R483	C-CARBON R	RN72K1J-223JE	1		NSP
R484	C-CARBON R	RN72K1J-103JE	1		NSP
R485	C-CARBON R	RN72K1J-103JE	1		NSP
R486	C-CARBON R	RN72K1J-103JE	1		NSP
R487	C-CARBON R	RN72K1J-103JE	1		NSP
R490	C-CARBON R	RN72K1J-102JE	1		NSP
R491	C-CARBON R	RN72K1J-102JE	1		NSP
R498	C-CARBON R	RN72K1J-100JE	1		NSP
R499	C-CARBON R	RN72K1J-100JE	1		NSP

R501	C-CARBON R	RN72K1J-473JE	1		NSP
R503	C-CARBON R	RN72K1J-103JE	1		NSP
R504	C-CARBON R	RN72K1J-000JE	1		NSP
R505	C-CARBON R	RN72K1J-103JE	1		NSP
R506	C-CARBON R	RN72K1J-221JE	1		NSP
R508	C-CARBON R	RN72K1J-105JE	1		NSP
R509	C-CARBON R	RN72K1J-221JE	1		NSP
R510	C-CARBON R	RN72K1J-470JE	1		NSP
R511	C-CARBON R	RN72K1J-473JE	1		NSP
R512	C-CARBON R	RN72K1J-221JE	1		NSP
R514	C-CARBON R	RN72K1J-470JE	1		NSP
R515	C-CARBON R	RN72K1J-470JE	1		NSP
R516	C-CARBON R	RN72K1J-470JE	1		NSP
R517	C-CARBON R	RN72K1J-470JE	1		NSP
R518	C-CARBON R	RN72K1J-103JE	1		NSP
R519	C-CARBON R	RN72K1J-470JE	1		NSP
R520	C-CARBON R	RN72K1J-103JE	1		NSP
R521	C-CARBON R	RN72K1J-470JE	1		NSP
R522	C-CARBON R	RN72K1J-470JE	1		NSP
R523	C-CARBON R	RN72K1J-470JE	1		NSP
R527	C-CARBON R	RN72K1J-470JE	1		NSP
R529	C-CARBON R	RN72K1J-470JE	1		NSP
R530	C-CARBON R	RN72K1J-470JE	1		NSP
R531	C-CARBON R	RN72K1J-103JE	1		NSP
R532	C-CARBON R	RN72K1J-472JE	1		NSP
R533	C-CARBON R	RN72K1J-472JE	1		NSP
R534	C-CARBON R	RN72K1J-223JE	1		NSP
R535	C-CARBON R	RN72K1J-223JE	1		NSP
R536	C-CARBON R	RN72K1J-223JE	1		NSP
R537	C-CARBON R	RN72K1J-223JE	1		NSP
R538	C-CARBON R	RN72K1J-103JE	1		NSP
R539	C-CARBON R	RN72K1J-470JE	1		NSP
R540	C-CARBON R	RN72K1J-470JE	1		NSP
R541	C-CARBON R	RN72K1J-470JE	1		NSP
R542	C-CARBON R	RN72K1J-470JE	1		NSP
R543	C-CARBON R	RN72K1J-103JE	1		NSP
R544	C-CARBON R	RN72K1J-221JE	1		NSP
R545	C-CARBON R	RN72K1J-221JE	1		NSP
R546	C-CARBON R	RN72K1J-221JE	1		NSP
R547	C-CARBON R	RN72K1J-221JE	1		NSP
R548	C-CARBON R	RN72K1J-221JE	1		NSP

R550	C-CARBON R	RN72K1J-470JE	1		NSP
R551	C-CARBON R	RN72K1J-103JE	1		NSP
R552	C-CARBON R	RN72K1J-103JE	1		NSP
R553	C-CARBON R	RN72K1J-470JE	1		NSP
R554	C-CARBON R	RN72K1J-103JE	1		NSP
R556	C-CARBON R	RN72K1J-470JE	1		NSP
R557	C-CARBON R	RN72K1J-103JE	1		NSP
R558	C-CARBON R	RN72K1J-470JE	1		NSP
R559	C-CARBON R	RN72K1J-272JE	1		NSP
R562	C-CARBON R	RN72K1J-103JE	1		NSP
R563	C-CARBON R	RN72K1J-103JE	1		NSP
R565	C-CARBON R	RN72K1J-470JE	1		NSP
R566	C-CARBON R	RN72K1J-222JE	1		NSP
R567	C-CARBON R	RN72K1J-470JE	1		NSP
R568	C-CARBON R	RN72K1J-222JE	1		NSP
R569	C-CARBON R	RN72K1J-102JE	1		NSP
R570	C-CARBON R	RN72K1J-273JE	1		NSP
R571	C-CARBON R	RN72K1J-102JE	1		NSP
R572	C-CARBON R	RN72K1J-273JE	1		NSP
R573	C-CARBON R	RN72K1J-221JE	1		NSP
R574	C-CARBON R	RN72K1J-470JE	1		NSP
R575	C-CARBON R	RN72K1J-470JE	1		NSP
R576	C-CARBON R	RN72K1J-470JE	1		NSP
R578	C-CARBON R	RN72K1J-470JE	1		NSP
R579	C-CARBON R	RN72K1J-470JE	1		NSP
R580	C-CARBON R	RN72K1J-103JE	1		NSP
R581	C-CARBON R	RN72K1J-103JE	1		NSP
R582	C-CARBON R	RN72K1J-221JE	1		NSP
R583	C-CARBON R	RN72K1J-221JE	1		NSP
R584	C-CARBON R	RN72K1J-103JE	1		NSP
R585	C-CARBON R	RN72K1J-221JE	1		NSP
R586	C-CARBON R	RN72K1J-103JE	1		NSP
R587	C-CARBON R	RN72K1J-221JE	1		NSP
R588	C-CARBON R	RN72K1J-103JE	1		NSP
R589	C-CARBON R	RN72K1J-470JE	1		NSP
R590	C-CARBON R	RN72K1J-103JE	1		NSP
R591	C-CARBON R	RN72K1J-470JE	1		NSP
R592	C-CARBON R	RN72K1J-470JE	1		NSP
R593	C-CARBON R	RN72K1J-221JE	1		NSP
R594	C-CARBON R	RN72K1J-221JE	1		NSP
R595	C-CARBON R	RN72K1J-221JE	1		NSP

R596	C-CARBON R	RN72K1J-103JE	1		NSP
R597	C-CARBON R	RN72K1J-470JE	1		NSP
R598	C-CARBON R	RN72K1J-221JE	1		NSP
R599	C-CARBON R	RN72K1J-103JE	1		NSP
R600	C-CARBON R	RN72K1J-103JE	1		NSP
R601	C-CARBON R	RN72K1J-470JE	1		NSP
R602	C-CARBON R	RN72K1J-470JE	1		NSP
R603	C-CARBON R	RN72K1J-470JE	1		NSP
R604	C-CARBON R	RN72K1J-103JE	1		NSP
R605	C-CARBON R	RN72K1J-221JE	1		NSP
R606	C-CARBON R	RN72K1J-470JE	1		NSP
R607	C-CARBON R	RN72K1J-470JE	1		NSP
R608	C-CARBON R	RN72K1J-470JE	1		NSP
R609	C-CARBON R	RN72K1J-102JE	1		NSP
R611	C-CARBON R	RN72K1J-102JE	1		NSP
R613	C-CARBON R	RN72K1J-102JE	1		NSP
R614	C-CARBON R	RN72K1J-103JE	1		NSP
R615	C-CARBON R	RN72K1J-101JE	1		NSP
R616	C-CARBON R	RN72K1J-103JE	1		NSP
R617	C-CARBON R	RN72K1J-221JE	1		NSP
R618	C-CARBON R	RN72K1J-103JE	1		NSP
R619	C-CARBON R	RN72K1J-470JE	1		NSP
R620	C-CARBON R	RN72K1J-103JE	1		NSP
R621	C-CARBON R	RN72K1J-221JE	1		NSP
R622	C-CARBON R	RN72K1J-470JE	1		NSP
R623	C-CARBON R	RN72K1J-103JE	1		NSP
R625	C-CARBON R	RN72K1J-470JE	1		NSP
R626	C-CARBON R	RN72K1J-103JE	1		NSP
R627	C-CARBON R	RN72K1J-000JE	1		NSP
R628	C-CARBON R	RN72K1J-221JE	1		NSP
R629	C-CARBON R	RN72K1J-221JE	1		NSP
R630	C-CARBON R	RN72K1J-221JE	1		NSP
R631	C-CARBON R	RN72K1J-470JE	1		NSP
R632	C-CARBON R	RN72K1J-470JE	1		NSP
R633	C-CARBON R	RN72K1J-103JE	1		NSP
R634	C-CARBON R	RN72K1J-470JE	1		NSP
R635	C-CARBON R	RN72K1J-103JE	1		NSP
R636	C-CARBON R	RN72K1J-470JE	1		NSP
R638	C-CARBON R	RN72K1J-470JE	1		NSP
R639	C-CARBON R	RN72K1J-103JE	1		NSP
R640	C-CARBON R	RN72K1J-470JE	1		NSP

R641	C-CARBON R	RN72K1J-103JE	1		NSP	
R642	C-CARBON R	RN72K1J-221JE	1		NSP	
R643	C-CARBON R	RN72K1J-103JE	1		NSP	
R644	C-CARBON R	RN72K1J-221JE	1		NSP	
R645	C-CARBON R	RN72K1J-103JE	1		NSP	
R646	C-CARBON R	RN72K1J-221JE	1		NSP	
R647	C-CARBON R	RN72K1J-103JE	1		NSP	
R648	C-CARBON R	RN72K1J-221JE	1		NSP	
R650	C-CARBON R	RN72K1J-221JE	1		NSP	
R651	C-CARBON R	RN72K1J-103JE	1		NSP	
R652	C-CARBON R	RN72K1J-102JE	1		NSP	
R653	C-CARBON R	RN72K1J-105JE	1		NSP	
R654	C-CARBON R	RN72K1J-103JE	1		NSP	
R655	C-CARBON R	RN72K1J-221JE	1		NSP	
R656	C-CARBON R	RN72K1J-221JE	1		NSP	
R658	C-CARBON R	RN72K1J-221JE	1		NSP	
R659	C-CARBON R	RN72K1J-273JE	1		NSP	
R660	C-CARBON R	RN72K1J-221JE	1		NSP	
R661	C-CARBON R	RN72K1J-221JE	1		NSP	
R662	C-CARBON R	RN72K1J-000JE	1		NSP	
R664	C-CARBON R	RN72K1J-000JE	1		NSP	
R666	C-CARBON R	RN72K1J-000JE	1		NSP	
R668	C-CARBON R	RN72K1J-103JE	1		NSP	<MDC, MDD, MDF>
R669	C-CARBON R	RN72K1J-103JE	1		NSP	<MMO, MMQ, MPA, MPP, MMR>
R669	C-CARBON R	RN72K1J-333JE	1		NSP	<MDC, MDD, MDF>
R670	C-CARBON R	RN72K1J-472JE	1		NSP	
R671	C-CARBON R	RN72K1J-272JE	1		NSP	
R672	C-CARBON R	RN72K1J-472JE	1		NSP	
R673	C-CARBON R	RN72K1J-272JE	1		NSP	
R674	C-CARBON R	RN72K1J-472JE	1		NSP	
R675	C-CARBON R	RN72K1J-272JE	1		NSP	
R676	C-CARBON R	RN72K1J-472JE	1		NSP	
R677	C-CARBON R	RN72K1J-272JE	1		NSP	
R681	C-CARBON R	RN72K1J-473JE	1		NSP	
R682	C-CARBON R	RN72K1J-103JE	1		NSP	
R683	C-CARBON R	RN72K1J-103JE	1		NSP	
R684	C-CARBON R	RN72K1J-000JE	1		NSP	
R685	C-CARBON R	RN72K1J-000JE	1		NSP	
R686	C-CARBON R	RN72K1J-103JE	1		NSP	
R687	C-CARBON R	RN72K1J-103JE	1		NSP	
R688	C-CARBON R	RN72K1J-103JE	1		NSP	

R691	C-CARBON R	RN72K1J-103JE	1			NSP	
R693	C-CARBON R	RN72K1J-103JE	1			NSP	
R694	C-CARBON R	RN72K1J-221JE	1			NSP	
R695	C-CARBON R	RN72K1J-221JE	1			NSP	
R696	C-CARBON R	RN72K1J-470JE	1			NSP	
R697	C-CARBON R	RN72K1J-470JE	1			NSP	
R698	C-CARBON R	RN72K1J-103JE	1			NSP	
R701	C-CARBON R	RN72K1J-000JE	1			NSP	
R706	C-CARBON R	RN72K1J-000JE	1			NSP	
R708	C-CARBON R	RN72K1J-103JE	1			NSP	
R709	C-CARBON R	RN72K1J-103JE	1			NSP	
R712	C-CARBON R	RN72K1J-102JE	1			NSP	
R713	C-CARBON R	RN72K1J-222JE	1			NSP	
R714	C-CARBON R	RN72K1J-103JE	1			NSP	
R715	C-CARBON R	RN72K1J-103JE	1			NSP	
R716	C-CARBON R	RN72K1J-470JE	1			NSP	
R721	C-CARBON R	RN72K1J-103JE	1			NSP	
R723	C-CARBON R	RN72K1J-101JE	1			NSP	
R724	C-CARBON R	RN72K1J-101JE	1			NSP	
R725	C-CARBON R	RN72K1J-221JE	1			NSP	
R726	C-CARBON R	RN72K1J-273JE	1			NSP	
R771	C-CARBON R	RN72K1J-103JE	1			NSP	
R772	C-CARBON R	RN72K1J-222JE	1			NSP	
R773	C-CARBON R	RN72K1J-102JE	1			NSP	
R801	C-CARBON R	RN72K1J-000JE	1			NSP	
R807	C-CARBON R	RN72K1J-000JE	1			NSP	
R811	C-CARBON R	RN72K1J-000JE	1			NSP	
R813	C-CARBON R	RN72K1J-000JE	1			NSP	
R823	C-CARBON R	RN72K1J-000JE	1			NSP	
R824	C-CARBON R	RN72K1J-000JE	1			NSP	
[SW TRM]							
JL501B	WIRE TRAP	NPLG-3P586	1	25055624			
JL502B	WIRE TRAP	NPLG-5P588	1	25055626			
JL901B	WIRE TRAP	NPLG-5P588	1	25055626			
P101A	SOCKET	NSCT-11P2104	1	25052207			
P131	PIN JACK	NPJ-1PDO554	1	25045772			
P2001A	SOCKET	IMSA-9142S-24A	1	25053234			
P2002B	SOCKET	NSCT-15P2195	1	25052298			
P2081	SOCKET	NNA1-01-006	1	25053357			
P5501A	SOCKET	NSCT-7P2187	1	25052290			
P5502A	SOCKET	NSCT-15P2195	1	25052298			

P5503A	SOCKET	NSCT-9P2189	1	25052292			
P5504A	SOCKET	NSCT-7P2187	1	25052290			
P701A	SOCKET	NSCT-31P2124	1	25052227			
P751A	SOCKET	IMSA-9618S-09A	1	25053334R2			
P8001A	PLUG	IMSA-9111B-16	1	25056620			
P8002A	PLUG	IMSA-9111B-24	1	25056625			

TX-SR308

PC BOARD PARTS LIST

U004	DIS-AS (DISPLAY ASSY) (U0040/41/42/43/44)	BADIS-0373-1A *	1	1B247573-1A	N	<MDC, MDD, MDF>
U004	DIS-AS (DISPLAY ASSY) (U0040/41/42/43/44)	BADIS-0373-1B *	1	1B247573-1B	N	<MMO, MMQ, MPA, MPP, MMR>
U0040	DIS-AS (DISPLAY)	BADIS-0373-1A	1	1B2475373-1A	N	<MDC, MDD, MDF>
U0040	DIS-AS (DISPLAY)	BADIS-0373-1B	1	1B2475373-1B	N	<MMO, MMQ, MPA, MPP, MMR>
U0041	PWB (STANDBY/LED)	BADIS-0374-1A	1	Included in "REF, NO, U0040"	N	<MDC, MDD, MDF>
U0041	PWB (STANDBY/LED)	BADIS-0374-1B	1	Included in "REF, NO, U0040"	N	<MMO, MMQ, MPA, MPP, MMR>
U0042	PWB (VIDEO)	BAVD-0375-1A	1	1B2475375-1A	N	<MDC, MDD, MDF>
U0042	PWB (VIDEO)	BAVD-0375-1B	1	1B2475375-1B	N	<MMO, MMQ, MPA, MPP, MMR>
U0043	PWB (POW-SUPPLY)	BAETC-0376-1A	1	1B2475376-1A	N	<MDC, MDD, MDF>
U0043	PWB (POW-SUPPLY)	BAETC-0376-1B	1	1B2475376-1B	N	<MMO, MMQ, MPA, MPP, MMR>
U0044	PWB (HP-JACK)	BAETC-0377-1A	1	1B2475377-1A	N	<MDC, MDD, MDF>
U0044	PWB (HP-JACK)	BAETC-0377-1B	1	1B2475377-1B	N	<MMO, MMQ, MPA, MPP, MMR>

CIRCUIT. N (PART NAME) DESCRIPTION Q'TY PART NO. (SN) REMARKS

[TUNER UNIT]

U7041	REMO SENS	KSM-603TE5B	1	24130019		
[SEMI CONDUCTOR]						
D7002	ZENER D	UDZS8.2B	1	224550820R2		
D7033	ZENER D	UDZS3.9B	1	224550390R2		
D7151	LED	SLI-343URC-TE7	1	225449T		
D7152	LED	SLI-343Y8C-TE7	1	225490T	N	
D9011	DIODE	D5SBA20	1	22380130F		
D9014	C-DIODE	KDS4148U	1			NSP
D9014 or	C-DIODE	1SS352	(1)			NSP
D9014 or	C-DIODE	MA2J111	(1)			NSP
D9015	C-DIODE	KDS4148U	1			NSP
D9015 or	C-DIODE	1SS352	(1)			NSP
D9015 or	C-DIODE	MA2J111	(1)			NSP
D9016	ZENER D	UDZS6.2B	1	224550620R2		
D9023	C-DIODE	KDS4148U	1			NSP

D9023 or	C-DIODE	1SS352	(1)		NSP	
D9023 or	C-DIODE	MA2J111	(1)		NSP	
D9025	C-DIODE	KDS4148U	1		NSP	
D9025 or	C-DIODE	1SS352	(1)		NSP	
D9025 or	C-DIODE	MA2J111	(1)		NSP	
D9032	C-DIODE	KDS4148U	1		NSP	
D9032 or	C-DIODE	1SS352	(1)		NSP	
D9032 or	C-DIODE	MA2J111	(1)		NSP	
D911	C-DIODE	KDS4148U	1		NSP	
D911 or	C-DIODE	1SS352	(1)		NSP	
D911 or	C-DIODE	MA2J111	(1)		NSP	
D912	C-DIODE	KDS4148U	1		NSP	
D912 or	C-DIODE	1SS352	(1)		NSP	
D912 or	C-DIODE	MA2J111	(1)		NSP	
D921	C-DIODE	KDS4148U	1		NSP	
D921 or	C-DIODE	1SS352	(1)		NSP	
D921 or	C-DIODE	MA2J111	(1)		NSP	
D922	C-DIODE	KDS4148U	1		NSP	
D922 or	C-DIODE	1SS352	(1)		NSP	
D922 or	C-DIODE	MA2J111	(1)		NSP	
D923	C-DIODE	KDS4148U	1		NSP	
D923 or	C-DIODE	1SS352	(1)		NSP	
D923 or	C-DIODE	MA2J111	(1)		NSP	
D924	C-DIODE	KDS4148U	1		NSP	
D924 or	C-DIODE	1SS352	(1)		NSP	
D924 or	C-DIODE	MA2J111	(1)		NSP	
D925	C-DIODE	KDS4148U	1		NSP	
D925 or	C-DIODE	1SS352	(1)		NSP	
D925 or	C-DIODE	MA2J111	(1)		NSP	
D930	C-DIODE	KDS4148U	1		NSP	
D930 or	C-DIODE	1SS352	(1)		NSP	
D930 or	C-DIODE	MA2J111	(1)		NSP	
D931	C-DIODE	KDS4148U	1		NSP	
D931 or	C-DIODE	1SS352	(1)		NSP	
D931 or	C-DIODE	MA2J111	(1)		NSP	
D933	C-DIODE	KDS4148U	1		NSP	
D933 or	C-DIODE	1SS352	(1)		NSP	
D933 or	C-DIODE	MA2J111	(1)		NSP	
D934	ZENER D	UDZS5.6B	1	224550560R2		<MMO,MMQ, MPA, MPP, MMR>
D934	ZENER D	UDZS5.1B	1	224550510R2		<MDC,MDF,MDF>
D935	C-DIODE	KDS4148U	1		NSP	

D935 or	C-DIODE	1SS352	(1)			NSP	
D935 or	C-DIODE	MA2J111	(1)			NSP	
Q2001	IC	NJW1326FH2	1	22242583R3			
Q2002	IC	NJM2505AF	1	22242490R2			
Q2002 or	IC	BH7673G	(1)	22242661R2		N	
Q7002	FL TUBE	16-BT-162GNK	1	212273			
Q7002A	HOLDER	(FL)	1	27191222C			
Q7003	IC	M66005-0001AHP	1	22242208R3			
Q7004	TR	KTC3875-GR	1	2216175R2			
Q7033	TR	KTC3875-GR	1	2216175R2			
Q9022	IC	78M05(NJM78M05FA)	1	222780055JRC			
Q9022 or	IC	78M05AHF(MPC78M05AHF)	(1)	222780055NEC			
Q9022A	SCREW	3P+10FN(3BC)	1			NSP	
Q9022B	HEAT SINK	RAD-157	1			NSP	
Q9031	IC	MPC2905BHF	1	22278005DBNE			
Q9031A	SCREW	3P+10FN(3BC)	1			NSP	
Q9031B	HEAT SINK	RAD-140	1			NSP	
[TRANS COIL]							
L7031	CHOKE COIL	LBC2518T2R2M	1	231364M022R2			
L7032	CHOKE COIL	LBC2518T2R2M	1	231364M022R2			
L7201	CHOKE COIL	LBC2518T2R2M	1	231364M022R2			
L7202	CHOKE COIL	LBC2518T2R2M	1	231364M022R2			
L7203	CHOKE COIL	LBC2518T2R2M	1	231364M022R2			
T902	P TRANS	(!) NPT-1520JQ	1	2301812A			<MDC, MDD,MDF>
T902	P TRANS	(!) NPT-1520GQ	1	2301813A			<MMO, MMQ, MPA, MPP, MMR>
[CAPACITOR]							
C2001	VR C	CE04W50V-10M(VR)	1	394681007T			
C2002	C-CERA C	CK725F1E-104Z1	1			NSP	
C2003	VR C	CE04W6.3V-470M(VR)	1	394624717T			
C2004	C-CERA C	CC725CH1H-470J1	1			NSP	
C2005	VR C	CE04W6.3V-470M(VR)	1	394624717T			
C2006	C-CERA C	CC725CH1H-470J1	1			NSP	
C2011	C-CERA C	CK725F1A-105Z1	1			NSP	
C2012	C-CERA C	CK725F1A-105Z1	1			NSP	
C2013	C-CERA C	CK725F1A-105Z1	1			NSP	
C2014	C-CERA C	CK725F1A-105Z1	1			NSP	
C2015	C-CERA C	CK725F1A-105Z1	1			NSP	
C2016	C-CERA C	CK725F1A-105Z1	1			NSP	
C2017	C-CERA C	CK725F1A-105Z1	1			NSP	
C2018	C-CERA C	CK725F1A-105Z1	1			NSP	
C2019	C-CERA C	CK725F1A-105Z1	1			NSP	

C2020	C-CERA C	CK725F1A-105Z1	1		NSP
C2021	C-CERA C	CK725F1A-105Z1	1		NSP
C2022	C-CERA C	CK725F1A-105Z1	1		NSP
C2101	VR C	CE04W50V-10M(VR)	1	394681007T	
C2102	VR C	CE04W6.3V-470M(VR)	1	394624717T	
C2103	VR C	CE04W50V-10M(VR)	1	394681007T	
C2104	VR C	CE04W50V-10M(VR)	1	394681007T	
C2105	VR C	CE04W6.3V-470M(VR)	1	394624717T	
C2106	VR C	CE04W50V-10M(VR)	1	394681007T	
C2107	VR C	CE04W50V-10M(VR)	1	394681007T	
C2108	VR C	CE04W6.3V-470M(VR)	1	394624717T	
C2109	VR C	CE04W6.3V-470M(VR)	1	394624717T	
C2110	VR C	CE04W6.3V-470M(VR)	1	394624717T	
C2111	VR C	CE04W50V-1M(VR)	1	394680107T	
C2112	VR C	CE04W50V-1M(VR)	1	394680107T	
C2113	VR C	CE04W50V-1M(VR)	1	394680107T	
C2114	VR C	CE04W50V-1M(VR)	1	394680107T	
C2115	VR C	CE04W50V-1M(VR)	1	394680107T	
C2116	VR C	CE04W50V-1M(VR)	1	394680107T	
C2201	C-CERA C	CK725B1H-102K1	1		NSP
C2202	C-CERA C	CK725B1H-102K1	1		NSP
C2203	C-CERA C	CK725B1H-103K1	1		NSP
C7001	C-CERA C	CK725B1H-223K1	1		NSP
C7002	C-CERA C	CK725F1E-104Z1	1		NSP
C7003	C-CERA C	CC725CH1H-101J1	1		NSP
C7004	C-CERA C	CC725CH1H-101J1	1		NSP
C7005	C-CERA C	CC725CH1H-101J1	1		NSP
C7007	C-CERA C	CC725CH1H-101J1	1		NSP
C7008	ELECT C	CE04W6.3V-100M	1	355721019T	
C7009	C-CERA C	CK725F1E-104Z1	1		NSP
C7010	C-CERA C	CK725B1H-223K1	1		NSP
C7011	C-CERA C	CK725B1H-223K1	1		NSP
C7012	C-CERA C	CK725B1H-223K1	1		NSP
C7013	ELECT C	CE04W50V-33M	1	355783309T	
C7014	C-CERA C	CK725B1H-223K1	1		NSP
C7015	ELECT C	CE04W16V-47M(S)	1	353744709T	
C7016	C-CERA C	CK725B1H-223K1	1		NSP
C7017	C-CERA C	CK725B1H-223K1	1		NSP
C7021	C-CERA C	CK725B1H-103K1	1		NSP
C7022	C-CERA C	CK725B1H-103K1	1		NSP
C7031	C-CERA C	CK725B1H-223K1	1		NSP

C7032	C-CERA C	CK725B1H-223K1	1			NSP	
C7033	ELECT C	CE04W16V-10M(S)	1	353741009T			
C7041	ELECT C	CE04W6.3V-100M(S)	1	353721019T			
C7042	C-CERA C	CC725CH1H-102J1	1			NSP	
C7043	C-CERA C	CC725CH1H-102J1	1			NSP	
C7201	C-CERA C	CC725CH1H-102J1	1			NSP	
C7202	C-CERA C	CK725B1H-223K1	1			NSP	
C7203	MKT C	B32529C0102J289	1	376491024T			
C7204	MKT C	B32529C0102J289	1	376491024T			
C7301	C-CERA C	CC725CH1H-471J1	1			NSP	
C7302	C-CERA C	CC725CH1H-471J1	1			NSP	
C7303	C-CERA C	CK725F1E-104Z1	1			NSP	
C7305	C-CERA C	CK725F1E-104Z1	1			NSP	
C901	IS C	LE103-C3.5	1	3800042S			
C901 or	IS C	ECQU2A103MLC	(1)	3800039S			
C9011	VR C	CE04W16V-10000M(VR)	1	394641037S			
C9012	TF C	ECQ-V50V-334J	1	374723344T			
C9013	VR C	CE04W50V-4.7M(VR)	1	394680477T			
C902	C-CERA C	CK725F1E-104Z1	1			NSP	
C9023	VR C	CE04W50V-10M(VR)	1	394681007T			
C9025	VR C	CE04W6.3V-470M(VR)	1	394624717T			
C9026	VR C	CE04W6.3V-470M(VR)	1	394624717T			
C9027	C-CERA C	CK725F1E-104Z1	1			NSP	
C9028	VR C	CE04W6.3V-470M(VR)	1	394624717T			
C9029	C-CERA C	CK725F1E-104Z1	1			NSP	
C9030	VR C	CE04W25V-220M(VR)	1	394652217T			
C9031	C-CERA C	CK725F1E-104Z1	1			NSP	
C9032	VR C	CE04W6.3V-470M(VR)	1	394624717T			
C911	C-CERA C	CC725CH1H-102J1	1			NSP	
C921	C-CERA C	CK725B1H-223K1	1			NSP	
C922	VR C	CE04W25V-2200M(VR)	1	394652227S			
C930	UTSP C	CE04W50V-100M(UTSP)	1	397581017T			
C933	UTSP C	CE04W50V-4.7M(UTSP)	1	397580477T			
[RESISTOR]							
R2001	C-CARBON R	RN72K1J-220JE	1			NSP	
R2002	C-CARBON R	RN72K1J-220JE	1			NSP	
R2003	C-CARBON R	RN72K1J-105JE	1			NSP	
R2101	C-CARBON R	RN72K1J-750JE	1			NSP	
R2102	C-CARBON R	RN72K1J-750JE	1			NSP	
R2103	C-CARBON R	RN72K1J-750JE	1			NSP	
R2104	C-CARBON R	RN72K1J-750JE	1			NSP	

R2105	C-CARBON R	RN72K1J-750JE	1		NSP
R2106	C-CARBON R	RN72K1J-750JE	1		NSP
R2107	C-CARBON R	RN72K1J-750JE	1		NSP
R2108	C-CARBON R	RN72K1J-750JE	1		NSP
R2109	C-CARBON R	RN72K1J-750JE	1		NSP
R2110	C-CARBON R	RN72K1J-750JE	1		NSP
R2111	C-CARBON R	RN72K1J-750JE	1		NSP
R2112	C-CARBON R	RN72K1J-750JE	1		NSP
R2113	C-CARBON R	RN72K1J-750JE	1		NSP
R2114	C-CARBON R	RN72K1J-750JE	1		NSP
R2115	C-CARBON R	RN72K1J-750JE	1		NSP
R2116	C-CARBON R	RN72K1J-750JE	1		NSP
R2155	C-CARBON R	RN72K1J-000JE	1		NSP
R2156	C-CARBON R	RN72K1J-000JE	1		NSP
R2157	C-CARBON R	RN72K1J-000JE	1		NSP
R7001	C-CARBON R	RN72K1J-103JE	1		NSP
R7002	C-CARBON R	RN72K1J-332JE	1		NSP
R7003	C-CARBON R	RN72K1J-332JE	1		NSP
R7004	C-CARBON R	RN72K1J-221JE	1		NSP
R7005	C-CARBON R	RN72K1J-221JE	1		NSP
R7006	C-CARBON R	RN72K1J-103JE	1		NSP
R7007	C-CARBON R	RN72K1J-221JE	1		NSP
R7008	C-CARBON R	RN72K1J-221JE	1		NSP
R7021	C-CARBON R	RN72K1J-103JE	1		NSP
R7022	C-CARBON R	RN72K1J-103JE	1		NSP
R7023	C-CARBON R	RN72K1J-103JE	1		NSP
R7024	C-CARBON R	RN72K1J-103JE	1		NSP
R7033	C-CARBON R	RN72K1J-820JE	1		NSP
R7041	C-CARBON R	RN72K1J-101JE	1		NSP
R7042	C-CARBON R	RN72K1J-102JE	1		NSP
R7101	C-CARBON R	RN72K1J-271JE	1		NSP
R7102	C-CARBON R	RN72K1J-331JE	1		NSP
R7103	C-CARBON R	RN72K1J-471JE	1		NSP
R7106	C-CARBON R	RN72K1J-271JE	1		NSP
R7107	C-CARBON R	RN72K1J-331JE	1		NSP
R7108	C-CARBON R	RN72K1J-471JE	1		NSP
R7109	C-CARBON R	RN72K1J-561JE	1		NSP
R7110	C-CARBON R	RN72K1J-821JE	1		NSP
R7111	C-CARBON R	RN72K1J-122JE	1		NSP
R7112	C-CARBON R	RN72K1J-222JE	1		NSP
R7113	C-CARBON R	RN72K1J-392JE	1		NSP

R7114	C-CARBON R	RN72K1J-123JE	1			NSP
R7115	C-CARBON R	RN72K1J-271JE	1			NSP
R7116	C-CARBON R	RN72K1J-331JE	1			NSP
R7117	C-CARBON R	RN72K1J-471JE	1			NSP
R7118	C-CARBON R	RN72K1J-561JE	1			NSP
R7119	C-CARBON R	RN72K1J-821JE	1			NSP
R7120	C-CARBON R	RN72K1J-122JE	1			NSP
R7121	C-CARBON R	RN72K1J-222JE	1			NSP
R7122	C-CARBON R	RN72K1J-392JE	1			NSP
R7123	C-CARBON R	RN72K1J-271JE	1			NSP
R7124	C-CARBON R	RN72K1J-331JE	1			NSP
R7125	C-CARBON R	RN72K1J-471JE	1			NSP
R7126	C-CARBON R	RN72K1J-561JE	1			NSP
R7127	C-CARBON R	RN72K1J-821JE	1			NSP
R7128	C-CARBON R	RN72K1J-122JE	1			NSP
R7129	C-CARBON R	RN72K1J-222JE	1			NSP
R7130	C-CARBON R	RN72K1J-000JE	1			NSP
R7151	C-CARBON R	RN72K1J-222JE	1			NSP
R7152	C-CARBON R	RN72K1J-222JE	1			NSP
R7301	C-CARBON R	RN72K1J-331JE	1			NSP
R7302	C-CARBON R	RN72K1J-331JE	1			NSP
R7304	C-CARBON R	RN72K1J-000JE	1			NSP
R9012	METAL R	RNU1/2WCJ-1	1	453530104T		
R9013	METAL R	RNU1/2WCJ-1	1	453530104T		
R9014	C-CARBON R	RN72K1J-104JE	1			NSP
R9020	METAL O R	RS1WBJ-8.2	1	441620824F		
R9021	METAL O R	RS1WBJ-8.2	1	441620824F		
R9022	METAL R	RNU1/2WCJ-1	1	453530104T		
R9031	METAL R	RNU2WCJ-3.3	1	452730334F		
R9032	METAL R	RNU2WCJ-3.3	1	452730334F		
R9033	METAL R	RNU1/2WCJ-1	1	453530104T		
R921	METAL O R	RS1/2WBJ-47	1	443524704T		
R934	C-CARBON R	RN72K1J-104JE	1			NSP
[SW TRM]						
E7201	TRM-423(SCREW)	NEJITANSI ST3	1	25060495		
E7301A	RETAINER	(EARTH)	1	27142136A		
E9001	TRM-423(SCREW)	NEJITANSI ST3	1	25060495		
E9003	TRM-423(SCREW)	NEJITANSI ST3	1	25060495		
E901	TRM-423(SCREW)	NEJITANSI ST3	1	25060495		
E902	TRM-423(SCREW)	NEJITANSI ST3	1	25060495		
F901C	FUSE HOL	NSCT-1P2031	1	25052133T		

F901D	FUSE HOL	NSCT-1P2031	1	25052133T			
F901E	LABEL	LABEL	1	29360842			<MDC, MDD, MDF>
F901E	LABEL	T4AL250V	1	29361732A			<MMO, MMQ, MPA, MPP, MMR>
JL503B	WIRE TRAP	NPLG-3P586	1	25055624			
JL605A	WIRE HOL	NSCT-5P896	1	25051109			
JL702A	WIRE HOL	NSCT-9P880	1	25051093			
JL702B	WIRE HOL	NSCT-9P880	1	25051093			
JL801A	WIRE HOL	NSCT-5P876	1	25051089			
JL901A	WIRE HOL	NSCT-5P876	1	25051089			
JL952B	SOCKET	NSCT-3P95	1	25050267			
JL953A	WIRE HOL	NSCT-5P876	1	25051089			
P2001B	PLUG	IMSA-9142B-24A	1	25056602			
P2002A	PLUG	NPLG-15P0970	1	25056020			
P2201	PIN JACK	NPJ-3PDYYY560	1	25045778			
P2202	PIN JACK	NPJ-3PDYYY560	1	25045778			
P2203	PIN JACK	NPJ-9PDGLRGLRGLR563	1	25045781			
P2203 or	PIN JACK	NPJ-9PDGLR519	(1)	25045731			
P701B	SOCKET	NSCT-31P2161	1	25052264			
P7201	ST JACK	MSJ-064-05A SR	1	25045783			
P7201 or	ST JACK	YKB21-5005	(1)	25045724			
P7311	ST JACK	MSJ-035-05A BAG SR LF	1	25045927			
P901A	PLUG	NPLG-2P631	1	25055675			
P901Aor	PLUG	1-1123724-2	(1)	25056402			
P911	PLUG	NPLG-2P631	1	25055675			
P911 or	PLUG	1-1123724-2	(1)	25056402			
RL901	RELAY (!)	NRL-1P5A-DC9-179	1	25065669			
S7002	R ENCODE	EC12E2425WITH WASHER	1	25065655W			
S7102	PUSH SW	NPS-111-S681	1	25035718T			
S7104	PUSH SW	NPS-111-S681	1	25035718T			
S7106	PUSH SW	NPS-111-S681	1	25035718T			
S7108	PUSH SW	NPS-111-S681	1	25035718T			
S7113	PUSH SW	NPS-111-S681	1	25035718T			
S7115	PUSH SW	NPS-111-S681	1	25035718T			
S7117	PUSH SW	NPS-111-S681	1	25035718T			
S7119	PUSH SW	NPS-111-S681	1	25035718T			
S7123	PUSH SW	NPS-111-S681	1	25035718T			
S7125	PUSH SW	NPS-111-S681	1	25035718T			
S7127	PUSH SW	NPS-111-S681	1	25035718T			
S7129	PUSH SW	NPS-111-S681	1	25035718T			
S7132	PUSH SW	NPS-111-S681	1	25035718T			
S7134	PUSH SW	NPS-111-S681	1	25035718T			

S7136	PUSH SW	NPS-111-S681	1	25035718T			
S7138	PUSH SW	NPS-111-S681	1	25035718T			
S7140	PUSH SW	NPS-111-S681	1	25035718T			
S7142	PUSH SW	NPS-111-S681	1	25035718T			
S7144	PUSH SW	NPS-111-S681	1	25035718T			
S7146	PUSH SW	NPS-111-S681	1	25035718T			
S7148	PUSH SW	NPS-111-S681	1	25035718T			
S7150	PUSH SW	NPS-111-S681	1	25035718T			
S7152	PUSH SW	NPS-111-S681	1	25035718T			
S7154	PUSH SW	NPS-111-S681	1	25035718T			
S7156	PUSH SW	NPS-111-S681	1	25035718T			
S7158	PUSH SW	NPS-111-S681	1	25035718T			
S7160	PUSH SW	NPS-111-S681	1	25035718T			
S7162	PUSH SW	NPS-111-S681	1	25035718T			
S7164	PUSH SW	NPS-111-S681	1	25035718T			

TX-SR308

PC BOARD PARTS LIST

U007	HDM-AS (HDMI ASSY)	BAHDM-0401-1A *	1	1B247501-1A	N		
-------------	--------------------	-----------------	---	-------------	---	--	--

CIRCUIT. N°	PART NAME	DESCRIPTION	Q'TY	PART NO. (SN)		REMARKS
[SEMI CONDUCTOR]						
D8100	C-DIODE	KDS4148U	1			NSP
D8100 or	C-DIODE	1SS352	(1)			NSP
D8100 or	C-DIODE	1SS355	(1)			NSP
D8100 or	C-DIODE	MA2J111	(1)			NSP
D8951	DIODE	XBS303V17R	1	22380365R2		
D8971	DIODE	XBS303V17R	1	22380365R2		
Q201	IC	D788E001BRFP266Z	1	22242502R3		
Q203	IC	TC7WU04FU(TE12L_F)	1	22240935R2		
Q203 or	IC	TC7WZU04FU(TE12L_F)	(1)	22242078R2TO		
Q271	IC	XC6220B121PR	1	22242626R2	N	
Q281	IC	K4S641632N-LC60	1	22242603R2		
Q281 or	IC	EM638165TS-7G	(1)	22242607R2		
Q282	IC (DSP, Flash memory)	ES29LV160ET-70TG(0372)	1	222W0069R303726		
Q282 or	IC (DSP, Flash memory)	S29AL016J70TFI010(0372)	(1)	222W0100R303726		
Q282 or	IC (DSP, Flash memory)	ES29LV160FT-70T(0372)	(1)	222W0101R303726		
Q282 or	IC (DSP, Flash memory)	MX29LV160DTT1-7(0372)	(1)	222W0104R303726		
Q8101	IC	ADV7623	1	22242625R3	N	
Q8104	IC	S-812C50BUC-C5ET2G	1	22242407R2		
Q8105	IC (OSD, Flash memory)	EN25Q32A-100HIP(0378)	1	222W0112R203785		

Q8111	TR	RN1401(TE85L_F)	1	2214460R2			
Q8111 or	TR	KRC101S	(1)	2216330R2			
Q8112	TR	RN1401(TE85L_F)	1	2214460R2			
Q8112 or	TR	KRC101S	(1)	2216330R2			
Q8113	TR	RN1401(TE85L_F)	1	2214460R2			
Q8113 or	TR	KRC101S	(1)	2216330R2			
Q8114	TR	RN1401(TE85L_F)	1	2214460R2			
Q8114 or	TR	KRC101S	(1)	2216330R2			
Q8115	TR	RN1401(TE85L_F)	1	2214460R2			
Q8115 or	TR	KRC101S	(1)	2216330R2			
Q8116	TR	RN1401(TE85L_F)	1	2214460R2			
Q8116 or	TR	KRC101S	(1)	2216330R2			
Q8951	IC	MP2363DN-LF-Z	1	22242627R2		N	
Q8971	IC	MP2363DN-LF-Z	1	22242627R2		N	
Q8972	IC	XC6221B182MR	1	22242632R2			
[TRANS COIL]							
L203	C-CARBON R	RN72K1J-000JE	1			NSP	
L204	EMIFIL	BK1608LM182-T	1	230958R1			
L206	EMIFIL	BK1608LM182-T	1	230958R1			
L261	CORE	BLM18PG181SN1D	1	2350005R1			
L262	CORE	NFM18PC105R0J3D	1	2350014R1		N	
L263	CORE	BLM18PG181SN1D	1	2350005R1			
L271	CORE	BLM18PG181SN1D	1	2350005R1			
L281	CORE	BLM18PG181SN1D	1	2350005R1			
L8101	EMIFIL	BK1608LM182-T	1	230958R1			
L8102	C-R NET	MNR12E0APJ000	1			NSP	
L8103	C-R NET	MNR12E0APJ000	1			NSP	
L8104	C-R NET	MNR12E0APJ000	1			NSP	
L8105	C-R NET	MNR12E0APJ000	1			NSP	
L8911	CORE	BLM18PG181SN1D	1	2350005R1			
L8912	CORE	BLM18PG181SN1D	1	2350005R1			
L8931	CORE	BLM18PG181SN1D	1	2350005R1			
L8932	CORE	BLM18PG181SN1D	1	2350005R1			
L8933	CORE	BLM18PG181SN1D	1	2350005R1			
L8937	CORE	BLM18PG181SN1D	1	2350005R1			
L8938	CORE	BLM18PG181SN1D	1	2350005R1			
L8939	CORE	BLM18PG181SN1D	1	2350005R1			
L8951	CHOKE COIL	0182-7E08Q-100M-RA	1	231396M100R2			
L8952	CORE	BLM18PG181SN1D	1	2350005R1			
L8953	CORE	BLM18PG181SN1D	1	2350005R1			
L8971	CHOKE COIL	0182-7E08Q-100M-RA	1	231396M100R2			

L8972	CORE	BLM18PG181SN1D	1	2350005R1		
L8973	CORE	BLM18PG181SN1D	1	2350005R1		
L8974	CORE	BLM18PG181SN1D	1	2350005R1		
X201	CRYSTAL	HC-49USMD17.734MHz	1	3010488R2		
X8100	CRYSTAL	HC-49USMD28.6363MHz	1	3010491R2	N	
[CAPACITOR]						
C201	C-CERA C	CK725F1E-104Z1	1			NSP
C202	C-CERA C	CK725F1E-104Z1	1			NSP
C203	C-CERA C	CK725F1E-104Z1	1			NSP
C204	C-CERA C	CK725F1E-104Z1	1			NSP
C205	C-CERA C	CK725F1E-104Z1	1			NSP
C206	C-CERA C	CK725F1E-104Z1	1			NSP
C207	C-CERA C	CK725F1E-104Z1	1			NSP
C208	C-CERA C	CK725F1E-104Z1	1			NSP
C209	C-CERA C	CK725F1E-104Z1	1			NSP
C210	C-CERA C	CK725F1E-104Z1	1			NSP
C211	C-CERA C	CK725F1E-104Z1	1			NSP
C212	C-CERA C	CK725F1E-104Z1	1			NSP
C213	C-CERA C	CK725F1E-104Z1	1			NSP
C214	C-CERA C	CK725F1E-104Z1	1			NSP
C215	C-CERA C	CK725F1E-104Z1	1			NSP
C216	C-CERA C	CK725F1E-104Z1	1			NSP
C221	C-CERA C	CK725F1E-104Z1	1			NSP
C222	C-CERA C	CK725F1E-104Z1	1			NSP
C223	C-CERA C	CK725F1E-104Z1	1			NSP
C224	C-CERA C	CK725F1E-104Z1	1			NSP
C225	C-CERA C	CK725F1E-104Z1	1			NSP
C226	C-CERA C	CK725F1E-104Z1	1			NSP
C227	C-CERA C	CK725F1E-104Z1	1			NSP
C228	C-CERA C	CK725F1E-104Z1	1			NSP
C229	C-CERA C	CK725F1E-104Z1	1			NSP
C230	C-CERA C	CK725F1E-104Z1	1			NSP
C231	C-CERA C	CK725F1E-104Z1	1			NSP
C232	C-CERA C	CK725F1E-104Z1	1			NSP
C233	C-CERA C	CK725F1E-104Z1	1			NSP
C236	C-CERA C	CC725CH1H-101J1	1			NSP
C238	C-CERA C	CC725CH1H-100D1	1			NSP
C239	C-CERA C	CC725CH1H-100D1	1			NSP
C240	C-CERA C	CC725CH1H-100D1	1			NSP
C242	C-CERA C	CK725F1E-104Z1	1			NSP
C243	C-CERA C	CK725B1H-102K1	1			NSP

C244	C-CERA C	CK725F1E-104Z1	1		NSP
C261	C-CERA C	CK725B0J-106K	1		NSP
C262	C-CERA C	CK725B0J-106K	1		NSP
C271	C-CERA C	CK725B0J-106K	1		NSP
C272	C-CERA C	CK725B0J-106K	1		NSP
C273	C-CERA C	CK725B0J-106K	1		NSP
C274	C-CERA C	CK725B0J-106K	1		NSP
C275	C-CERA C	CK725B0J-106K	1		NSP
C282	C-CERA C	CK725B0J-106K	1		NSP
C283	C-CERA C	CK725F1E-104Z1	1		NSP
C284	C-CERA C	CK725F1E-104Z1	1		NSP
C285	C-CERA C	CK725F1E-104Z1	1		NSP
C286	C-CERA C	CK725F1E-104Z1	1		NSP
C287	C-CERA C	CK725F1E-104Z1	1		NSP
C288	C-CERA C	CK725F1E-104Z1	1		NSP
C289	C-CERA C	CK725F1E-104Z1	1		NSP
C290	C-CERA C	CK725F1E-104Z1	1		NSP
C291	C-CERA C	CK725F1E-104Z1	1		NSP
C292	C-CERA C	CK725B1H-102K1	1		NSP
C293	C-CERA C	CK725B1H-102K1	1		NSP
C294	C-CERA C	CK725B1H-102K1	1		NSP
C295	C-CERA C	CK725B1H-102K1	1		NSP
C296	C-CERA C	CK725B1H-102K1	1		NSP
C8103	C-CERA C	CK725F1E-104Z1	1		NSP
C8104	C-CERA C	CK725B1H-102K1	1		NSP
C8105	C-CERA C	CK725F1E-104Z1	1		NSP
C8106	C-CERA C	CK725B1H-102K1	1		NSP
C8107	C-CERA C	CK725F1E-104Z1	1		NSP
C8108	C-CERA C	CK725B1H-102K1	1		NSP
C8109	C-CERA C	CK725F1E-104Z1	1		NSP
C8110	C-CERA C	CK725B1H-102K1	1		NSP
C8111	C-CERA C	CK725F1E-104Z1	1		NSP
C8112	C-CERA C	CK725B1H-102K1	1		NSP
C8113	C-CERA C	CK725F1E-104Z1	1		NSP
C8114	C-CERA C	CK725B1H-102K1	1		NSP
C8115	C-CERA C	CK725F1E-104Z1	1		NSP
C8116	C-CERA C	CK725B1H-102K1	1		NSP
C8118	C-CERA C	CK725B1H-102K1	1		NSP
C8119	C-CERA C	CK725F1E-104Z1	1		NSP
C8120	C-CERA C	CK725B1H-102K1	1		NSP
C8121	C-CERA C	CK725F1E-104Z1	1		NSP

C8122	C-CERA C	CK725F1E-104Z1	1		NSP
C8123	C-CERA C	CC725CH1H-070D1	1		NSP
C8124	C-CERA C	CK725B1H-102K1	1		NSP
C8125	C-CERA C	CK725B1H-102K1	1		NSP
C8126	C-CERA C	CK725F1E-104Z1	1		NSP
C8127	C-CERA C	CC725CH1H-070D1	1		NSP
C8128	C-CERA C	CK725B1H-102K1	1		NSP
C8129	C-CERA C	CK725F1E-104Z1	1		NSP
C8130	C-CERA C	CK725B1H-102K1	1		NSP
C8131	C-CERA C	CK725B1H-102K1	1		NSP
C8132	C-CERA C	CK725B1H-102K1	1		NSP
C8133	C-CERA C	CK725F1E-104Z1	1		NSP
C8134	C-CERA C	CK725B1H-102K1	1		NSP
C8135	C-CERA C	CK725F1E-104Z1	1		NSP
C8136	C-CERA C	CK725B1H-102K1	1		NSP
C8137	C-CERA C	CK725F1E-104Z1	1		NSP
C8138	C-CERA C	CK725B1H-102K1	1		NSP
C8139	C-CERA C	CK725B1H-102K1	1		NSP
C8140	C-CERA C	CK725F1E-104Z1	1		NSP
C8141	C-CERA C	CK725B1H-102K1	1		NSP
C8142	C-CERA C	CK725F1E-104Z1	1		NSP
C8143	C-CERA C	CK725B1H-102K1	1		NSP
C8144	C-CERA C	CK725B1H-102K1	1		NSP
C8145	C-CERA C	CK725B1H-102K1	1		NSP
C8146	C-CERA C	CK725F1E-104Z1	1		NSP
C8147	C-CERA C	CK725B1H-102K1	1		NSP
C8148	C-CERA C	CK725F1E-104Z1	1		NSP
C8149	C-CERA C	CK725B1H-102K1	1		NSP
C8151	C-CERA C	CK725F1E-104Z1	1		NSP
C8152	C-CERA C	CK725B1H-102K1	1		NSP
C8153	C-CERA C	CK725F1E-104Z1	1		NSP
C8154	C-CERA C	CK725B1H-102K1	1		NSP
C8155	C-CERA C	CK725F1E-104Z1	1		NSP
C8156	C-CERA C	CK725B1H-102K1	1		NSP
C8158	C-CERA C	CK725F1E-104Z1	1		NSP
C8159	C-CERA C	CK725B1H-102K1	1		NSP
C8160	C-CERA C	CK725F1E-104Z1	1		NSP
C8161	C-CERA C	CK725B1H-102K1	1		NSP
C8162	C-CERA C	CK725F1E-104Z1	1		NSP
C8163	C-CERA C	CK725B1H-102K1	1		NSP
C8164	C-CERA C	CK725F1E-104Z1	1		NSP

C8165	C-CERA C	CK725B1H-102K1	1			NSP
C8166	C-CERA C	CK725B1H-102K1	1			NSP
C8168	C-CERA C	CK725B1H-102K1	1			NSP
C8169	C-CERA C	CK725B1H-102K1	1			NSP
C8170	C-CERA C	CK725F1E-104Z1	1			NSP
C8172	C-CERA C	CK725B0J-106K	1			NSP
C8173	C-CERA C	CK725F1E-104Z1	1			NSP
C8175	C-CERA C	CK725B1H-102K1	1			NSP
C8176	C-CERA C	CK725F1A-105Z1	1			NSP
C8177	C-CERA C	CK725F1A-105Z1	1			NSP
C8911	C-CERA C	CK725B0J-106K	1			NSP
C8912	C-CERA C	CK725F1A-105Z1	1			NSP
C8931	C-CERA C	CK725B0J-106K	1			NSP
C8932	C-CERA C	CK725B0J-106K	1			NSP
C8933	C-CERA C	CK725F1A-105Z1	1			NSP
C8934	C-CERA C	CK725F1A-105Z1	1			NSP
C8935	C-CERA C	CK725F1A-105Z1	1			NSP
C8936	C-CERA C	CK725F1A-105Z1	1			NSP
C8950	CHIP ELECT C	CEWX16V-100M	1	398141017R2		
C8951	C-CERA C	CK725B1E-106K	1			N NSP
C8952	C-CERA C	CK725B1E-106K	1			N NSP
C8953	C-CERA C	CK725B0J-106K	1			NSP
C8954	C-CERA C	CK725B0J-106K	1			NSP
C8955	C-CERA C	CK725B0J-106K	1			NSP
C8956	CHIP ELECT C	CEWX16V-100M	1	398141017R2		
C8957	C-CERA C	CK725F1E-104Z1	1			NSP
C8958	C-CERA C	CK725B1H-223K1	1			NSP
C8959	C-CERA C	CK725F1E-104Z1	1			NSP
C8960	C-CERA C	CK725B1H-103K1	1			NSP
C8963	C-CERA C	CC725CH1H-151J1	1			NSP
C8971	C-CERA C	CK725B1E-106K	1			N NSP
C8972	C-CERA C	CK725B1E-106K	1			N NSP
C8973	C-CERA C	CK725B0J-106K	1			NSP
C8974	C-CERA C	CK725B0J-106K	1			NSP
C8975	C-CERA C	CK725B0J-106K	1			NSP
C8976	CHIP ELECT C	CEWX16V-100M	1	398141017R2		
C8977	C-CERA C	CK725F1E-104Z1	1			NSP
C8978	C-CERA C	CK725B1H-223K1	1			NSP
C8979	C-CERA C	CK725F1A-105Z1	1			NSP
C8980	C-CERA C	CK725B1H-682K1	1			NSP
C8983	C-CERA C	CK725F1A-105Z1	1			NSP

C8984	C-CERA C	CK725F1A-105Z1	1		NSP
C8985	C-CERA C	CK725F1A-105Z1	1		NSP
C8991	C-CERA C	CK725F1E-104Z1	1		NSP
C8992	C-CERA C	CK725F1E-104Z1	1		NSP
[RESISTOR]					
R200	C-CARBON R	RN72K1J-221JE	1		NSP
R201	C-CARBON R	RN72K1J-103JE	1		NSP
R202	C-CARBON R	RN72K1J-103JE	1		NSP
R203	C-CARBON R	RN72K1J-103JE	1		NSP
R205	C-CARBON R	RN72K1J-103JE	1		NSP
R206	C-CARBON R	RN72K1J-221JE	1		NSP
R207	C-CARBON R	RN72K1J-221JE	1		NSP
R208	C-CARBON R	RN72K1J-103JE	1		NSP
R209	C-CARBON R	RN72K1J-470JE	1		NSP
R210	C-R NET	RM7LJ330X04	1		NSP
R211	C-R NET	RM7LJ330X04	1		NSP
R212	C-R NET	RM7LJ330X04	1		NSP
R213	C-R NET	RM7LJ330X04	1		NSP
R214	C-R NET	RM7LJ330X04	1		NSP
R215	C-R NET	RM7LJ330X04	1		NSP
R216	C-R NET	RM7LJ330X04	1		NSP
R217	C-R NET	RM7LJ330X04	1		NSP
R218	C-R NET	RM7LJ330X04	1		NSP
R221	C-CARBON R	RN72K1J-750JE	1		NSP
R240	C-CARBON R	RN72K1J-331JE	1		NSP
R241	C-CARBON R	RN72K1J-331JE	1		NSP
R242	C-CARBON R	RN72K1J-470JE	1		NSP
R243	C-CARBON R	RN72K1J-221JE	1		NSP
R244	C-CARBON R	RN72K1J-470JE	1		NSP
R245	C-CARBON R	RN72K1J-103JE	1		NSP
R246	C-CARBON R	RN72K1J-000JE	1		NSP
R250	C-CARBON R	RN72K1J-472JE	1		NSP
R251	C-CARBON R	RN72K1J-221JE	1		NSP
R252	C-CARBON R	RN72K1J-331JE	1		NSP
R253	C-CARBON R	RN72K1J-470JE	1		NSP
R254	C-CARBON R	RN72K1J-470JE	1		NSP
R255	C-CARBON R	RN72K1J-470JE	1		NSP
R256	C-CARBON R	RN72K1J-470JE	1		NSP
R257	C-CARBON R	RN72K1J-470JE	1		NSP
R258	C-CARBON R	RN72K1J-470JE	1		NSP
R259	C-CARBON R	RN72K1J-331JE	1		NSP

R260	C-CARBON R	RN72K1J-470JE	1		NSP
R261	C-CARBON R	RN72K1J-470JE	1		NSP
R262	C-CARBON R	RN72K1J-331JE	1		NSP
R263	C-CARBON R	RN72K1J-331JE	1		NSP
R264	C-CARBON R	RN72K1J-331JE	1		NSP
R265	C-CARBON R	RN72K1J-470JE	1		NSP
R267	C-CARBON R	RN72K1J-105JE	1		NSP
R281	C-CARBON R	RN72K1J-103JE	1		NSP
R282	C-CARBON R	RN72K1J-103JE	1		NSP
R283	C-CARBON R	RN72K1J-103JE	1		NSP
R284	C-CARBON R	RN72K1J-103JE	1		NSP
R285	C-CARBON R	RN72K1J-103JE	1		NSP
R286	C-CARBON R	RN72K1J-331JE	1		NSP
R287	C-CARBON R	RN72K1J-103JE	1		NSP
R288	C-CARBON R	RN72K1J-103JE	1		NSP
R289	C-CARBON R	RN72K1J-472JE	1		NSP
R290	C-CARBON R	RN72K1J-472JE	1		NSP
R8118	C-CARBON R	RN72K1J-102JE	1		NSP
R8119	C-CARBON R	RN72K1J-102JE	1		NSP
R8120	C-CARBON R	RN72K1J-000JE	1		NSP
R8121	C-CARBON R	RN72K1J-102JE	1		NSP
R8122	C-CARBON R	RN72K1J-473JE	1		NSP
R8124	C-CARBON R	RN72K1J-103JE	1		NSP
R8125	C-CARBON R	RN72K1J-101JE	1		NSP
R8126	C-CARBON R	RN72K1J-101JE	1		NSP
R8127	C-CARBON R	RN72K1J-330JE	1		NSP
R8128	C-CARBON R	RN72K1J-331JE	1		NSP
R8129	C-CARBON R	RN72K1J-330JE	1		NSP
R8130	C-CARBON R	RN72K1J-103JE	1		NSP
R8131	C-R NET	RM7LJ330X04	1		NSP
R8132	C-CARBON R	RN72K1J-101JE	1		NSP
R8133	C-CARBON R	RN72K1J-103JE	1		NSP
R8134	C-CARBON R	RN72K1J-101JE	1		NSP
R8135	C-CARBON R	RN72K1J-101JE	1		NSP
R8136	C-CARBON R	RN72K1J-102JE	1		NSP
R8137	C-CARBON R	RN72K1J-101JE	1		NSP
R8138	C-CARBON R	RN72K1J-000JE	1		NSP
R8139	C-CARBON R	RN72K1J-103JE	1		NSP
R8140	C-CARBON R	RN72K1J-473JE	1		NSP
R8142	C-CARBON R	RN72K1J-220JE	1		NSP
R8144	C-CARBON R	RN72K1J-472JE	1		NSP

R8145	C-CARBON R	RN72K1J-472JE	1		NSP
R8146	C-CARBON R	RN72K1J-103JE	1		NSP
R8148	C-CARBON R	RN72K1J-473JE	1		NSP
R8150	C-CARBON R	RN72K1J-470JE	1		NSP
R8151	C-CARBON R	RN72K1J-470JE	1		NSP
R8152	C-CARBON R	RN72K1J-470JE	1		NSP
R8153	C-CARBON R	RN72K1J-470JE	1		NSP
R8154	C-CARBON R	RN72K1J-220JE	1		NSP
R8155	C-CARBON R	RN72K1J-220JE	1		NSP
R8156	C-CARBON R	RN72K1J-220JE	1		NSP
R8158	C-CARBON R	RN72K1J-473JE	1		NSP
R8159	C-CARBON R	RN72K1J-182JE	1		NSP
R8160	C-CARBON R	RN72K1J-182JE	1		NSP
R8161	C-CARBON R	RN72K1J-821FE	1		NSP
R8162	C-CARBON R	RN72K1J-680JE	1		NSP
R8164	C-CARBON R	RN72K1J-473JE	1		NSP
R8165	C-CARBON R	RN72K2E-470JE	1		NSP
R8166	C-CARBON R	RN72K1J-102JE	1		NSP
R8167	C-CARBON R	RN72K1J-000JE	1		NSP
R8169	C-CARBON R	RN72K1J-473JE	1		NSP
R8172	C-CARBON R	RN72K1J-103JE	1		NSP
R8177	C-CARBON R	RN72K1J-101JE	1		NSP
R8178	C-CARBON R	RN72K1J-101JE	1		NSP
R8179	C-CARBON R	RN72K1J-101JE	1		NSP
R8180	C-CARBON R	RN72K1J-101JE	1		NSP
R8181	C-CARBON R	RN72K1J-100JE	1		NSP
R8182	C-CARBON R	RN72K1J-100JE	1		NSP
R8191	C-CARBON R	RN72K1J-103JE	1		NSP
R8192	C-CARBON R	RN72K1J-103JE	1		NSP
R8193	C-CARBON R	RN72K1J-103JE	1		NSP
R8953	C-CARBON R	RN72K1J-273FE	1		NSP
R8955	C-CARBON R	RN72K1J-103FE	1		NSP
R8956	C-CARBON R	RN72K1J-562JE	1		NSP
R8971	C-CARBON R	RN72K1J-102JE	1		NSP
R8973	C-CARBON R	RN72K1J-103FE	1		NSP
R8975	C-CARBON R	RN72K1J-103FE	1		NSP
R8976	C-CARBON R	RN72K1J-332JE	1		NSP
R8991	C-CARBON R	RN72K1J-220JE	1		NSP
R8992	C-CARBON R	RN72K1J-220JE	1		NSP
[SW TRM]					
JL801B	WIRE TRAP	NPLG-5P588	1		NSP

P201	PLUG	IMSA-9204B-2-13Z122-GF	1	25056542			
P8001B	SOCKET	IMSA-9111S-24L	1	25053259			
P8002B	SOCKET	IMSA-9111S-16L	1	25053258			
P8102	SOCKET	YKF45-7037V	1	25053253R3			
P8103	SOCKET	YKF45-7037V	1	25053253R3			
P8104	SOCKET	YKF45-7037V	1	25053253R3			
P8105	SOCKET	YKF45-7037V	1	25053253R3			
P8901	SOCKET	IMSA-9618S-08A	1	25053333R2	N		

ONKYO CORPORATION

Service Dept. Technical Support : 2-1, Nisshin-cho, Neyagawa-shi, OSAKA 572-8540, JAPAN
Tel: 072-831-8023 Fax: 072-831-8163

ONKYO U.S.A. CORPORATION

18 Park Way, Upper Saddle River, N.J. 07458, U.S.A.
Tel: 800-229-1687, 201-785-2600 Fax: 201-785-2650 <http://www.us.onkyo.com/>

ONKYO EUROPE ELECTRONICS GmbH

Liegnitzerstrasse 6, 82194 Groebenzell, GERMANY
Tel: +49-8142-4401-0 Fax: +49-8142-4401-555 <http://www.eu.onkyo.com/>

ONKYO EUROPE ELECTRONICS GmbH (UK BRANCH)

The Coach House 81A High Street, Marlow, Buckinghamshire, SL7 1AB, UK
Tel: +44-(0)1628-473-350 Fax: +44-(0)1628-401-700

ONKYO CHINA LIMITED

Unit 1&12, 9/F, Ever Gain Plaza Tower 1, 88, Container Port Road, Kwai Chung,
N.T., Hong Kong. Tel: 852-2429-3118 Fax: 852-2428-9039
<http://www.ch.onkyo.com/>

