



**LG**

North/Latin America  
Europe/Africa  
Asia/Oceania

Internal Use Only

<http://aic.lgservice.com>  
<http://eic.lgservice.com>  
<http://biz.lgservice.com>

# PLASMA TV

# SERVICE MANUAL

CHASSIS : PP78C

**MODEL : 32PC50**

**32PC50-ZB**

## CAUTION

BEFORE SERVICING THE CHASSIS,  
READ THE SAFETY PRECAUTIONS IN THIS MANUAL.

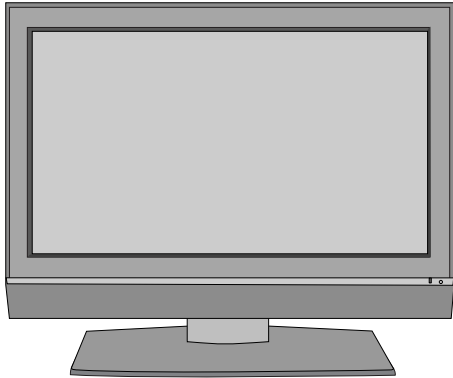

# CONTENTS

<b>CONTENTS .....</b>	<b>2</b>
<b>SAFETY PRECAUTIONS .....</b>	<b>3</b>
<b>SPECIFICATION .....</b>	<b>4</b>
<b>ADJUSTMENT INSTRUCTION .....</b>	<b>6</b>
<b>TROUBLE SHOOTING .....</b>	<b>13</b>
<b>BLOCK DIAGRAM.....</b>	<b>20</b>
<b>EXPLODED VIEW .....</b>	<b>21</b>
<b>SVC. SHEET .....</b>	
<b>PRINTED CIRCUIT DIAGRAM .....</b>	

# SAFETY PRECAUTIONS

## IMPORTANT SAFETY NOTICE

Many electrical and mechanical parts in this chassis have special safety-related characteristics. These parts are identified by  $\triangle$  in the Schematic Diagram and Exploded View.

It is essential that these special safety parts should be replaced with the same components as recommended in this manual to prevent X-RADIATION, Shock, Fire, or other Hazards.

Do not modify the original design without permission of manufacturer.

### General Guidance

An **isolation Transformer should always be used** during the servicing of a receiver whose chassis is not isolated from the AC power line. Use a transformer of adequate power rating as this protects the technician from accidents resulting in personal injury from electrical shocks.

It will also protect the receiver and its components from being damaged by accidental shorts of the circuitry that may be inadvertently introduced during the service operation.

If any fuse (or Fusible Resistor) in this monitor is blown, replace it with the specified.

When replacing a high wattage resistor (Oxide Metal Film Resistor, over 1W), keep the resistor 10mm away from PCB.

Keep wires away from high voltage or high temperature parts.

Due to high vacuum and large surface area of picture tube, extreme care should be used in **handling the Picture Tube**. Do not lift the Picture tube by its Neck.

### Leakage Current Cold Check(Antenna Cold Check)

With the instrument AC plug removed from AC source, connect an electrical jumper across the two AC plug prongs. Place the AC switch in the on position, connect one lead of ohm-meter to the AC plug prongs tied together and touch other ohm-meter lead in turn to each exposed metallic parts such as antenna terminals, phone jacks, etc.

If the exposed metallic part has a return path to the chassis, the measured resistance should be between  $1M\Omega$  and  $5.2M\Omega$ .

When the exposed metal has no return path to the chassis the reading must be infinite.

An other abnormality exists that must be corrected before the receiver is returned to the customer.

### Leakage Current Hot Check (See below Figure)

Plug the AC cord directly into the AC outlet.

**Do not use a line Isolation Transformer during this check.**

Connect 1.5K/10watt resistor in parallel with a 0.15uF capacitor between a known good earth ground (Water Pipe, Conduit, etc.) and the exposed metallic parts.

Measure the AC voltage across the resistor using AC voltmeter with 1000 ohms/volt or more sensitivity.

Reverse plug the AC cord into the AC outlet and repeat AC voltage measurements for each exposed metallic part. Any voltage measured must not exceed 0.75 volt RMS which corresponds to 0.5mA.

In case any measurement is out of the limits specified, there is possibility of shock hazard and the set must be checked and repaired before it is returned to the customer.

### Leakage Current Hot Check circuit

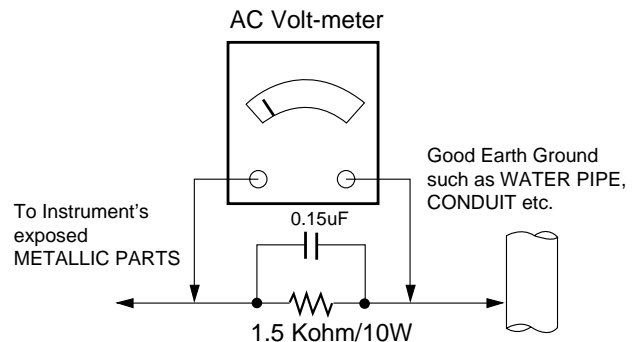

# SPECIFICATIONS

**NOTE :** Specifications and others are subject to change without notice for improvement.

√ **Application Range**

This spec is applied to the 32" PLASMA TV used PP78C Chassis.

Chassis	Model Name	Market	Brand	Remark
PP78C	32PC51-ZB 32PC50-ZB	EU	LG	

√ **Specification**

Each part is tested as below without special appointment.

- 1) Temperature : 25±5°C (77±9°F), CST : 40±5
- 2) Relative Humidity: 65±10%
- 3) Power Voltage: Standard Input voltage (100-240V~, 50/60Hz)  
\* Standard Voltage of each product is marked by models.
- 4) Specification and performance of each parts are followed each drawing and specification by part number in accordance with SBOM.
- 5) The receiver must be operated for about 20 minutes prior to the adjustment.

√ **Test Method**

- 1) Performance : LGE TV test method followed.
- 2) Demanded other specification  
Safety : CE, IEC specification  
EMC : CE, IEC

Model	Market	Appliance	Remark
32PC51-ZB 32PC50-ZB	EU	Safety : IEC/EN60065, EMI : EN55013, EMS : EN55020	TEST

√ **General Specification ( 32" WVGA )**

No	Item	Specification	Remark
1	Display Screen Device	32" Wide Color Display Module	Plasma Display Panel
2	Aspect Ratio	16:9	
3	PDP Module	PDP32F1, RGB Closed Type	Glass Filter
4	Operating Environment	1)Temp. : 0~40deg 2)Humidity : 0~85%	LGE SPEC.
5	Storage Environment	3)Temp. : -20~60deg 4)Humidity : 0~85%	
6	Input Voltage	100-240V~, 50/60Hz	Maker : LG

√ **General Specification2**

No	Item	Specification			Remark
1	Market	EU			
2	Broadcasting system	PAL-BG/I/DK, SECAM			
3	Available Channel	BAND	PAL	NTSC	
		VHF/UHF	C1~C69	2~83	
		CATV	S1~S47	1~71	
4	Receiving system	Upper Heterodyne			
5	SCART Jack(2EA)	PAL, SECAM, NTSC			Full SCART, Half SCART
6	Component Input (1EA)	Y/Cb/Cr, Y/Pb/Pr			
7	RGB Input(1EA)	RGB-PC			
8	HDMI Input(1EA)	HDMI-DTV			HDMI PC spec out
9	Audio Input (4EA)	PC Audio, Component(1EA),			L/R Input
10	Audio variable out(1EA)				

√ **Module Specification ( PDP32F1 )**

No	Item	Min	Typ	Max	Unit	Remark
1	Display area	708.0.1(H) x 398.4(V) ± 0.5mm			mm	
2	Outline dimension	790(H) x 466.5(V) x 59.1(D) ± 1mm			mm	
3	Number of Pixels	852(H) x 480(V)				1Pixel=3RGB Cells
4	Cell pitch	831um(H) x 830um(V)			um	1Pixel=3RGB Cells
5	Pixel type	RGB closed type				
6	Weight(net)	7.55	8.05	8.55	Kg	
7	Weight(gross)	118.5	123.5	128.5	Kg	12 1Box
8	Operation Environment	Temperature	0 ~ 40		deg	Altitude : 0 to 2000M
		Humidity	20 ~ 80		%	
		Pressure	800 ~ 1100		hPa	
9	Storage Environment	Temperature	-20 ~ 60		deg	Altitude : 0 to 3000M
		Humidity	10 ~ 90		%	
		Pressure	700 ~ 1100		hPa	
10	Image stick minimization mode	Start time	4.5	5	5.5	min
		Low Brightness	14	15	16	min
		Arrival Time				

# ADJUSTMENT INSTRUCTION

## 1. Application Object

These instructions are applied all of the 32" PLASMA TV, PP78C Chassis.

## 2. Note

- (1) Because this is not a hot chassis, it is not necessary to use an isolation transformer. However, the use of isolation transformer will help protect test instrument.
- (2) Adjustment must be done in the correct order.
- (3) The adjustment must be performed in the circumstance of  $25 \pm 5^\circ\text{C}$  of temperature and  $65 \pm 10\%$  of relative humidity if there is no specific designation.
- (4) The input voltage of the receiver must keep 100-220V~, 50/60Hz.
- (5) Before adjustment, execute Heat Run for 30 minutes.

## 3. Adjustment items

### 3.1. PCB assembly adjustment items

- (1) Download the VCTP main software (IC500,VCT\_Pro)
- (2) Color carrier Adjustment

### 3.2. SET assembly adjustment items

- (1) DDC Data input.
- (2) Adjustment of White Balance.
- (3) Factoring Option Data input.

## 4. PCB assembly adjustment method (Using VCTP Download program)

### 4-1. Download program installation

- (1) Extract a Zip file.



- (2) Visual I2C & LPT Driver Installation.



Install the LPT Driver  
Install the Visual I2C

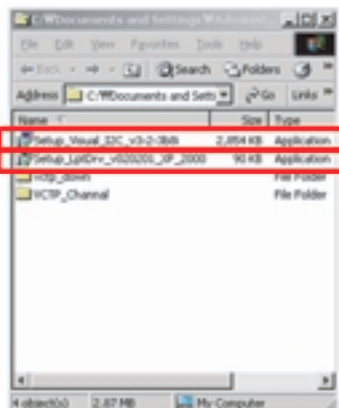

LPT Port Driver (LptDrv) Setups : Program Files > Micronas > Visual I2C > Port\_Driver

\*Use for Windows 95/98 : Setup\_LptDrv\_v0104\_9x.exe

\*Use for Windows 2000/XP : Setup\_LptDrv\_v0202\_XP\_2000.exe

\*Use for Windows NT : Setup\_LptDrv\_v0104\_NT.exe

- (3) Verification.(Start > Programs > Micronas > Visual I2C or LptDrv)

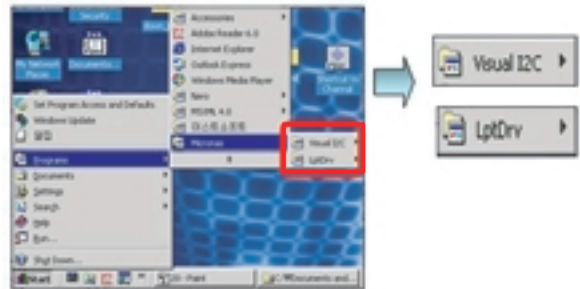

- (4) LPT delay setting.(File > Preference > LPT preferences)

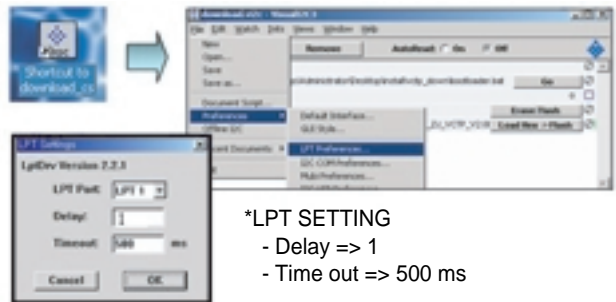

- (5) Exchange the "bootloader.bat" file.



Double click the Red area

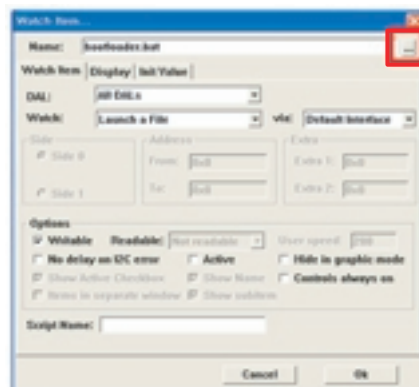

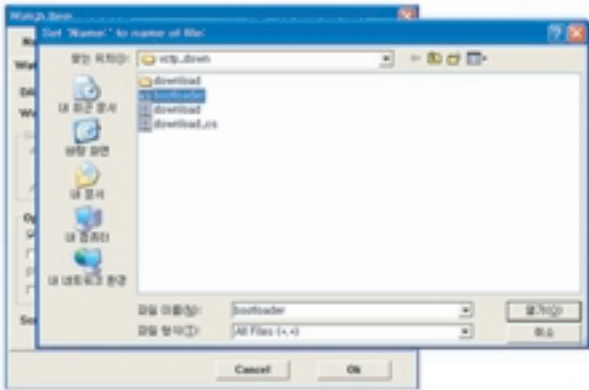

- Select the "Bootloader.bat" file.  
(install > VCTP\_download > Bootloader)
- Push "OK".

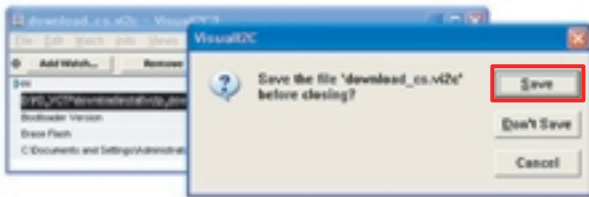

- Finish the program, after saving the file "download\_cs.vi2c".  
(if you click [X], the message appears automatically)

## 5. S/W program download

### 5-1. Download method 1 (PCB Ass'y)



- (1) Connect the download jig to D-sub jack.
- (2) Execute 'Download.vi2c' program in PC, then a main window will be opened.



Double click



- (3) Double click the blue box and confirm "Bootloader Version" as 42.



- (4) Click the "Erase Flash" button.

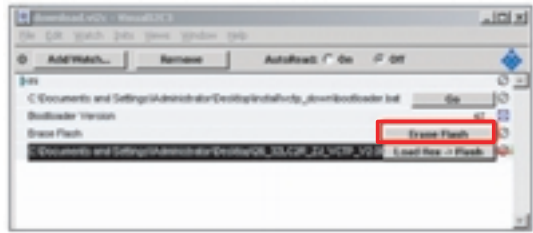

- (5) Double click the download file low, then "edit" window will be opened.

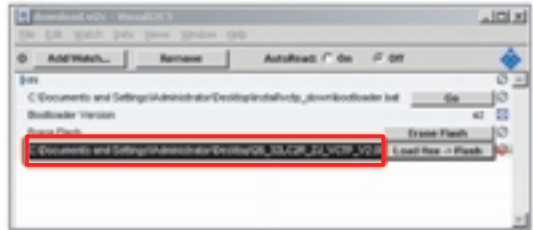

- (6) Click the choice button in the "edit window", then "file choice window" will be opened.

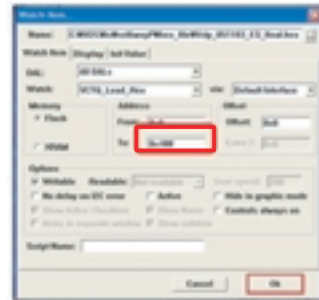

- (7) Choose the Hex file in folder and execute downloading with click " open" button.

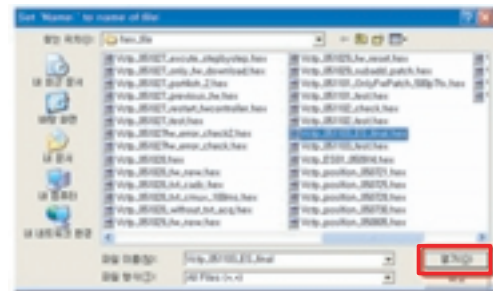

- (8) Click OK button at the "edit window".
- (9) Under Downloading process.



- (10) If download is failed, for example "No acknowledge from slave". Execute download again from(1).

## 5-2.Download method 2 (Set)

(1) Push the "Tilt" button in an Adjust Remocon Then the PLASMA TV will change a "slave mode".



(2) Connect Zig to TV using a D-sub cable.



(3) Execute 'Download\_CS.vi2c' program in PC, then a main window will be opened.



Double click



(4) Click "GO" button.



If you don't push the "go", the Hex file would not be downloaded although the download proceeds normally at first glance.

(5) Double click the blue box and confirm "Bootloader Version" as 42.



(6) Click the "Erase Flash" button.

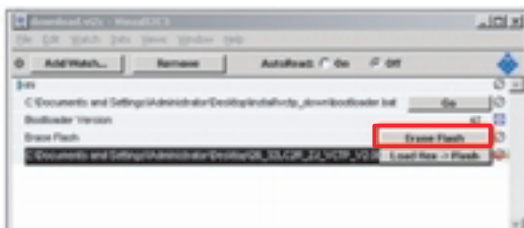

(7) Double click the download file low then, "edit" window will be opened.

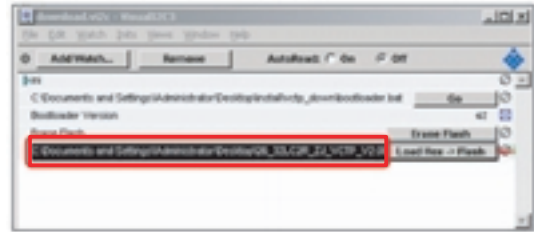

(8) Chck the choice button I n the "edit window", then "file choice window' will be opened.

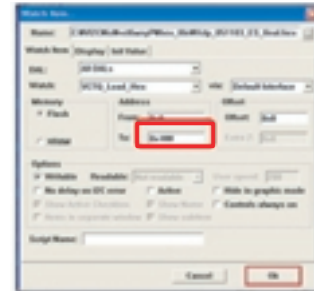

(9) Click the "load > flash" button.

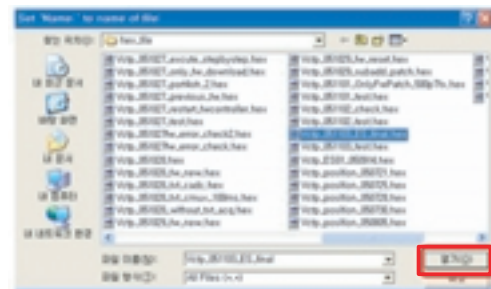

(10) Click OK button at the "edit window".

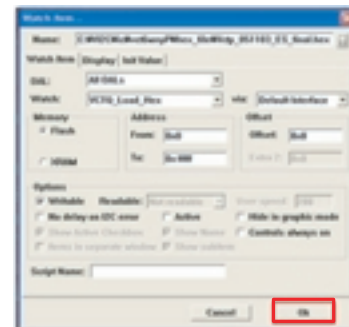

(11) Under Downloading progress.

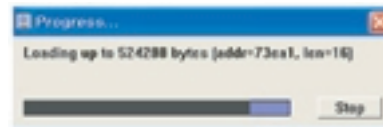

(12) If download is failed, for example "No acknowledge from slave", execute download again from (1).

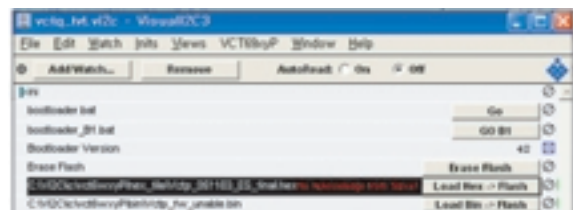



## 6. Tool Option Area Option Change

### 6-1. Adjustment method

Before PCB check, have to change the Tool option and Area option.  
Option values are below.  
(If on changed the option, the input menu can differ the model spec.)  
The input methods are same as other chassises.(Use adj Key on the Adjust Remocon)

Tool Option	ZB	TB/TD
32(VGA)	04164	
Area Option	Depend on PR	

## 7. Color carrier Adjustment (Inspection process)

- (1) tuning the RF signal  
ZB, TB/TD : PAL Philips Pattern (with Color Bar)



- (2) push the "adj" key in the adjustment remocon.

## 8. EDID(The Extended Display Identification Data) /DDC(Display Data Channel) download

- Use the proper signal cable for EDID Download.
- Never connect HDMI & D-SUB Cable at the same time.
- Use the proper cables below for EDID Writ.

For RGB EDID	For HDMI EDID	
		

### 8-1. EDID Data

No	Item	Condition	Hex Data
1	Manufacturer ID	GSM	1E6D
2	Version	Digital : 1	01
3	Revision	Digital : 2	03

<EDID Data Analog Set : 128Bytes >

Addr	00	01	02	03	04	05	06	07	08	09	0A	0B	0C	0D	0E	0F
0000	00	FF	FF	FF	FF	FF	FF	00	1E	6D	1				2	
0010		3	01	03	08	46	27	78	0A	D9	B0	A3	57	49	9C	25
0020	11	49	4B	A1	08	00	31	40	01	01	01	01	01	45	40	01
0030	61	40	01	01	01	01	05	09	80	A0	20	E0	2D	10	08	60
0040	22	00	98	06	32	08	08	18	64	19	00	40	41	00	26	30
0050	18	88	36	00	98	06	32	00	00	18	00	00	00	FD	00	3A
0060	3F	1F	32	09	00	0A	20	20	20	20	20	20			4	
0070															00	5

<EDID Data HDMI1 Set : 256Bytes >

Addr	00	01	02	03	04	05	06	07	08	09	0A	0B	0C	0D	0E	0F
0000	00	FF	FF	FF	FF	FF	FF	00	1E	6D	1				2	
0010		3	01	03	80	46	27	78	EA	D9	B0	A3	57	49	9C	25
0020	11	49	4B	81	08	00	01	01	01	01	01	01	45	40	01	01
0030	61	40	01	01	01	01	05	09	80	A0	20	E0	2D	10	08	60
0040	22	00	98	06	32	08	08	18	64	19	00	40	41	00	26	30
0050	18	88	36	00	98	06	32	00	00	18	00	00	00	FC	00	4C
0060	47	20	54	56	0A	20	20	20	20	20	20	20			4	
0070															01	5
0080	02	03	20	F1	40	01	06	07	15	16	02	03	11	12	13	04
0090	14	85	23	09	07	07	83	01	00	00	85	03	0C	00	20	00
00A0	01	1D	00	80	51	D0	1C	20	40	80	35	00	8C	88	21	00
00B0	00	1E	9C	0A	D0	8A	20	E0	20	10	10	3E	96	00	13	9E
00C0	21	00	00	18	01	1D	80	18	71	1C	16	20	58	2C	25	00
00D0	C4	8E	21	00	00	9E	00	00	00	00	00	00	00	00	00	00
00E0	00	00	00	00	00	00	00	00	00	00	00	00	00	00	00	00
00F0	00	00	00	00	00	00	00	00	00	00	00	00	00	00	00	5

<EDID Data HDMI2 Set : 256Bytes >

Addr	00	01	02	03	04	05	06	07	08	09	0A	0B	0C	0D	0E	0F
0000	00	FF	FF	FF	FF	FF	FF	00	1E	6D	1				2	
0010		3	01	03	80	46	27	78	EA	D9	B0	A3	57	49	9C	25
0020	11	49	4B	81	08	00	01	01	01	01	01	01	45	40	01	01
0030	61	40	01	01	01	01	05	09	80	A0	20	E0	2D	10	08	60
0040	22	00	98	06	32	08	08	18	64	19	00	40	41	00	26	30
0050	18	88	36	00	98	06	32	00	00	18	00	00	00	FC	00	4C
0060	47	20	54	56	0A	20	20	20	20	20	20	20			4	
0070															01	5
0080	02	03	20	F1	40	01	06	07	15	16	02	03	11	12	13	04
0090	14	85	23	09	07	07	83	01	00	00	85	03	0C	00	20	00
00A0	01	1D	00	80	51	D0	1C	20	40	80	35	00	8C	88	21	00
00B0	00	1E	9C	0A	D0	8A	20	E0	20	10	10	3E	96	00	13	9E
00C0	21	00	00	18	01	1D	80	18	71	1C	16	20	58	2C	25	00
00D0	C4	8E	21	00	00	9E	00	00	00	00	00	00	00	00	00	00
00E0	00	00	00	00	00	00	00	00	00	00	00	00	00	00	00	00
00F0	00	00	00	00	00	00	00	00	00	00	00	00	00	00	00	5

=> Detail EDID Options are below([1],[2],[3],[4],[5])

#### 1. [1]-Product ID

Model Name	Product ID		
	DEC	HEX	EDID table
32PC5R	30168(A)	75D8	D875
	30169(D)	75D9	D975
32PC51	30176(A)	75E0	E075
	30177(D)	75E1	E175

- [2]-Serial No : Controlled on production line
- [3]-Month, Year : Controlled on production line  
ex) Monthly: '03' => '03'  
Year: '2005' => '0F'
- [4]-Model Name : model name -> LG TV  
- LG TV

Model Name	Model Name(HEX)															
32PC5R	00	00	00	FD	00	3A	3F	1F	32	09	00	0A	20	20	20	20

- [5]-Checksum (7EH) -> Changeable by total EDID data.

## 8-2. Required Test Equipment

- (1) Adjusting PC with S/W for writing EDID Data.  
(S/W : EDID TESTER Ver.2.5)
- (2) A Jig for EDID Download.
- (3) Cable : Serial(9Pin or USB) to D-sub 15Pin cable, D-sub 15Pin cable, DVI to HDMI cable.



(Fig. 2) Connection Diagram of DDC download

## 8-3. Preparation for Adjustment

- (1) As above (Fig. 2), Connect the Set, EDID Download Jig, PC & Cable.
- (2) Turn on the PC & EDID Download Jig. And Execute the S/W : **EDID TESTER Ver 2.5.**
- (3) Set up S/W option.

**Repeat Number : 5**  
**Device Address : A0**  
**PageByte : 8**



- (4) Power on the Set.

## 8-4. Sequence of Adjustment

- (1) DDC data of Analog-RGB
  - 1) Init the data.



- 2) Load the EDID data.(Open File).

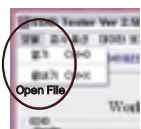

[ Analog-RGB : PP78C\_RGB.ANA ]  
 [ Digital-HDMI1 : PP78C\_HDMI1.DVI ]  
 [ Digital-HDMI2 : PP78C\_HDMI2.DVI ]

- 3) Set the S/W as below.

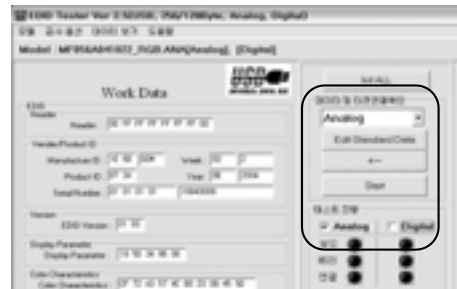

- 4) Push the "Write Data & Verify" button. And confirm "Yes".

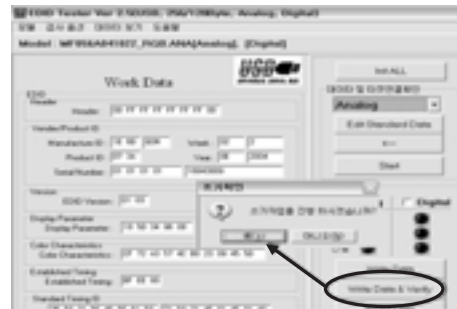

- 5) If the writing is finished, you will see the "OK" message.



## 9. Adjustment of White Balance

### 9-1. Purpose and Principle for adjustment of the color temperature

- (1) Purpose : Adjust the color temperature to reduce the deviation of the module color temperature.
- (2) Principle : To adjust the white balance without the saturation, Fix the one of R/G/B gain to 80 and decrease the others.

### 9-2. Adjustment mode

: Two modes of Cool and Warm.(Medium data is automatically calibrated by the cool data)

### 9-3. Required Equipment

- (1) Remote control for adjustment.
- (2) Color Analyzer : CA-100+, CA210 or same product.  
- Plasma TV(ch : 10)
- (3) Auto W/B adjustment instrument.(only for Auto adjustment)

### 9-4. Connecting diagram of equipment for measuring (For Automatic Adjustment)

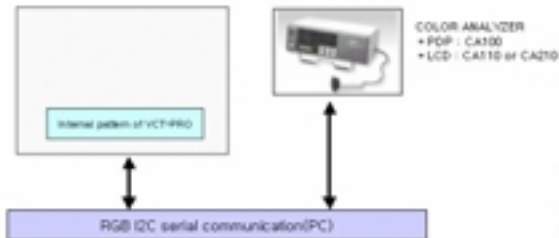

- (1) Enter the DDC adjust mode.
  - Enter the white balance adjustment mode at the same time heat-run mode when pushing the power on by power only key.
  - Maintain the white balance adjustment mode with same condition of Heat-run.
  - > Maintain after AC off/on in status of Heat-run pattern display.
- (2) Release the DDC adjust mode.
  - Release the adjust mode after AC off/on or std-by off/on in status of finishing the Hear-run mode.
  - Release the Adjust mode when receiving the aging off command(F3 00 00) from adjustment equipment.
  - Need to transmit the aging off command to TV set after finishing the adjustment.

\* Standard color coordinate and temperature when using the CA-100+ or CA210 equipment.

Mode	Color Coordinate		Temp	Δuv
	x	y		
COOL	0.276±0.003	0.283±0.003	11,000K	0.000
MEDIUM	0.283±0.003	0.295±0.003	9,300K	0.000
WARM	0.313±0.003	0.329±0.003	6,500K	0.003

\* Synchronization relation between PSM and CSM.

PSM	CSM	Remark
Dynamic	Cool	
Standard	Normal	
Mild	Warm	

(3) DDC adjustment support command set.

Adjustment	CMD(HEX)	ADR	VALUE	Detail
Aging On/Off	F3	00	FF/00	00 : OFF 01 : ON FF : WB Ready
Input select	F4	00		0x10 : TV 0x20 : AV1 0x21 : AV2 0x23 : AV3 0x40 : Component1 0x50 : RGB DTV 0x60 : RGB PC 0x90 : HDMI1 DTV
R GAIN	16	00	00 - FE	GAIN adjustment
G GAIN	18		00 - FE	CSM COOL
B GAIN	1A		00 - FE	
R GAIN	16	01	00 - FE	GAIN adjustment
G GAIN	18		00 - FE	CSM NORMAL
B GAIN	1A		00 - FE	
R GAIN	16	02	00 - FE	GAIN adjustment
G GAIN	18		00 - FE	CSM WARM
B GAIN	1A		00 - FE	

\* R/G/B GAIN max value : 80

### 9-5. Adjustment of White Balance (For Manual adjustment)

- Adjustment mode : Two modes of Cool (Dynamic) and Warm(Mild).  
(Medium data is automatically calibrated by the cool data)
- Color analyzer(CA110, CA210) should be used in the calibrated ch by CS-1000.(PDP : CH10)
- Operate the zero-calibration of the CA-110 or CA-210, then stick sensor to the module when adjusting.
- For manual adjustment, it is also possible by the following sequence.
  - (1) Select RF no signal by pressing "POWER ON" key on remote control for adjustment then operate heat run more than 15 minutes.  
(If not executed this step, the condition for W/B will be differ.)
  - (2) Changing to the av mode by pushing the input or front av key.(av mode : av1 or av2 or av3)
  - (3) Display the internal pattern of the VCT-Pro IC by pushing the IN-START.
  - (4) Stick sensor to center of the screen and select each items (Red/Green/Blue Gain and Offset) using D/E (CH+/-) key on R/C.
  - (5) Adjust R Gain / B Gain using F / G (VOL+/-) key on R/C.
  - (6) Adjust two modes of Cool(Dynamic) and Warm(Mild) as below figure.  
(Fix the one of R/G/B and change the others)
    1. Push the one time the in-start key : Dynamic(Cool)
    2. Push the two more the in-start key : Mild(Warm)

Mode	Color Coordinate		Temp	Δuv
	x	y		
COOL	0.276±0.003	0.283±0.003	11,000K	0.000
MEDIUM	0.283±0.003	0.295±0.003	9,300K	0.000
WARM	0.313±0.003	0.329±0.003	6,500K	0.003

\* Refer to the below case to know what value is fixed.

**\* CASE**

- First adjust the coordinate much away from the target value(x, y).

- 1) x, y > target
  - (1) Decrease the R, G.
  - 2) x, y < target
    - (1) First decrease the B gain.
    - (2) Decrease the one of the others.
      - In case of decreasing the x, decreasing the R : fix G
      - In case of decreasing the y , decreasing the G : fix R
- 3) x > target , y < target
  - (1) First decrease B, so make y a little more than the target.
  - (2) Adjust x value by decreasing the R.
- 4) x < target , y > target
  - (1) First decrease B, so make x a little more than the target.
  - (2) Adjust x value by decreasing the G.

(7) When adjustment is completed, Exit adjustment mode using EXIT key on R/C.

## 10. Default Value in Adjustment mode

(Default values maybe modified the module condition)

### 10-1. White Balance

White Balance		
RED	Gain	80
Green	Gain	80
Blue	Gain	80
Red	Offset	80
Green	Offset	80
Blue	Offset	80

<Default Value on OSD>

## 11. Internal press test

Item	Value	Unit	Remark
Dielectric Voltage (AC <-> FG)	1.5	kV	At 100mA for 1sec (Line)
	1.5		At 100mA for 1min (OQC)
Dielectric Voltage (Without FG)	3	kV	At 100mA for 1sec (Line)
	3		At 100mA for 1min (OQC)

## 12. Sound spec.

Item	Min	Typ	Max	Unit	Remark
Audio Practical Max Output, L(Mono)/R	9	10	12	W	

Each PCB assembly must be checked by check JIG set.  
(Because power PCB Assembly damages to PDP Module, especially be careful)

## 13. POWER PCB Assy Voltage Adjustments

(Va, Vs Voltage adjustments)

### 13-1. Profile

: To supply the Va, Vs voltage that the module want.

### 13-2. Required Test Equipment

- (1) Stick for adjustment.
- (2) DMM.

### 13-3. Connection Diagram for Measuring

: refer to (Fig. 1)

### 13-4. Adjustment Method

#### (1) Va Adjustment

- 1) After receiving 100% Full White Pattern, HEAT RUN.
- 2) Connect + terminal of D. M.M. to Va pin of P812, connect -terminal to GND pin of P812.
- 3) After turning VR901, voltage of D.M.M adjustment as same as Va voltage which on label of panel right/top. (deviation; ±0.5V)

#### (2) Vs Adjustment

- 1) Connect + terminal of D. M.M. to Vs pin of P812, connect -terminal to GND pin of P812.
- 2) After turning VR851, voltage of D.M.M adjustment as same as Vs voltage which on label of panel right/top. (deviation ; ±0.5V)

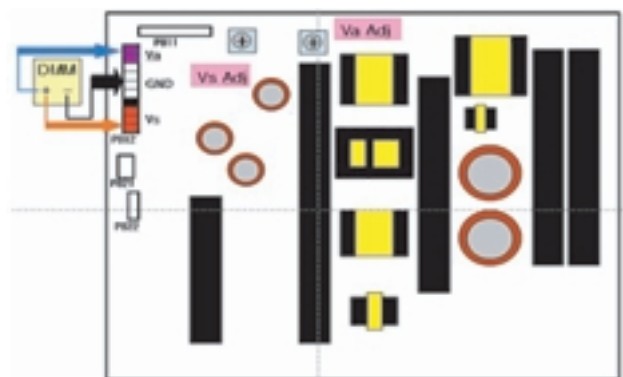

(Fig. 1) Connection Diagram of power adjustment for measuring.

## 14. Input the Shipping Option Data

- (1) Push the ADJ key in a Adjust Remote control.
- (2) Input the Option Number that was specified in the BOM, into the Shipping area.
- (3) The work is finished, Push A Key.

# TROUBLESHOOTING

## 1. No power

### (1) Symptom

- 1) Minute discharge does not occur at module.
- 2) Front LED does not activate.

### (2) Press check

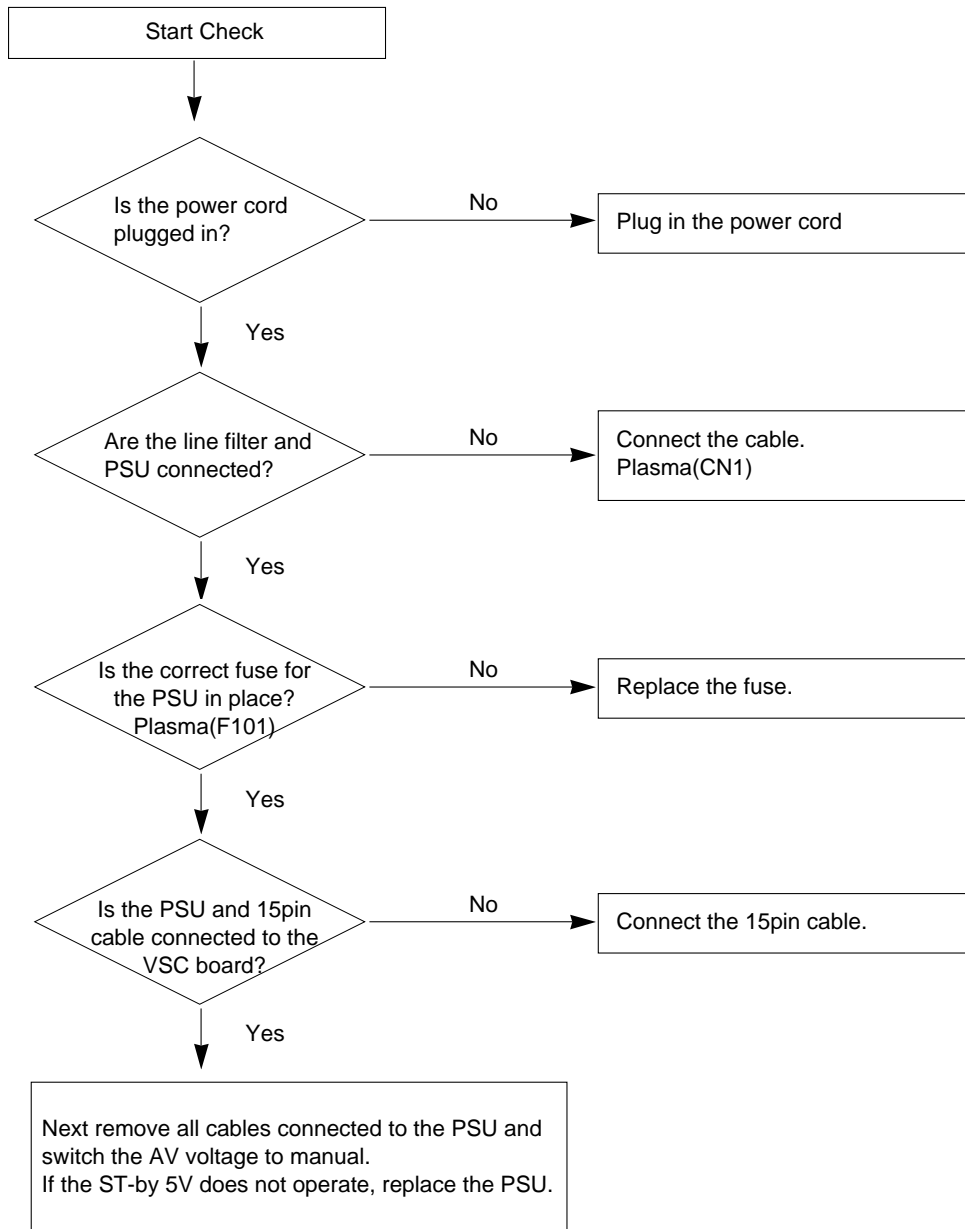
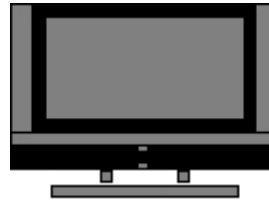

## 2. Protect mode

### (1) Symptom

- 1) After lighting once it does not discharge minutely from the module.
- 2) The relay falls.(there is an audible "Click".)
- 3) The color of the front LED turns from green to red.

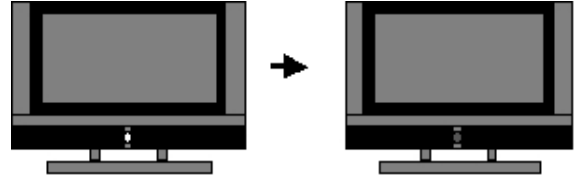

### (2) Follow check

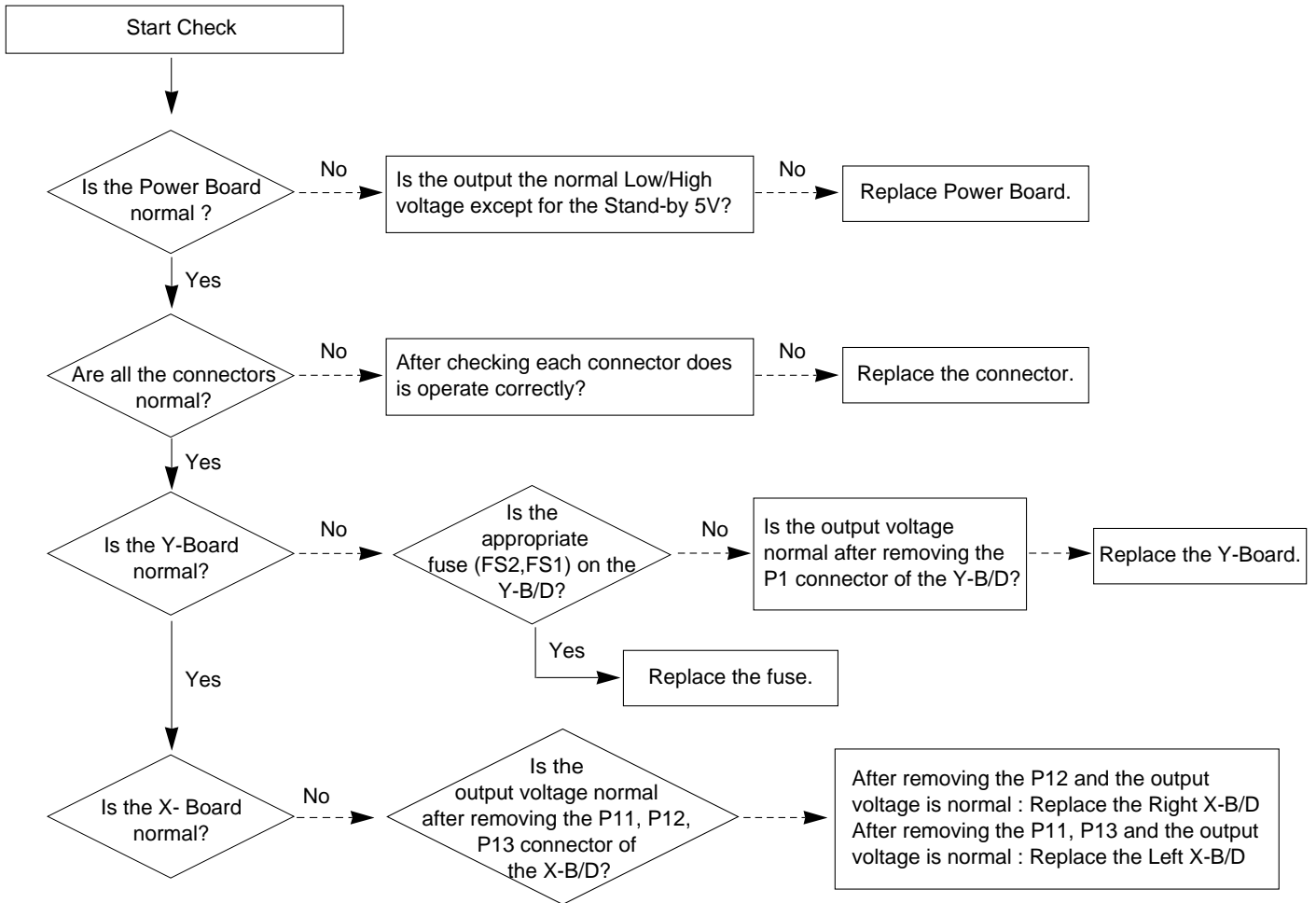

### 3. No Raster



**(1) Symptom**

- 1) No OSD or image are displayed on the screen.
- 2) The front LED remains green.

**(2) Follow check**

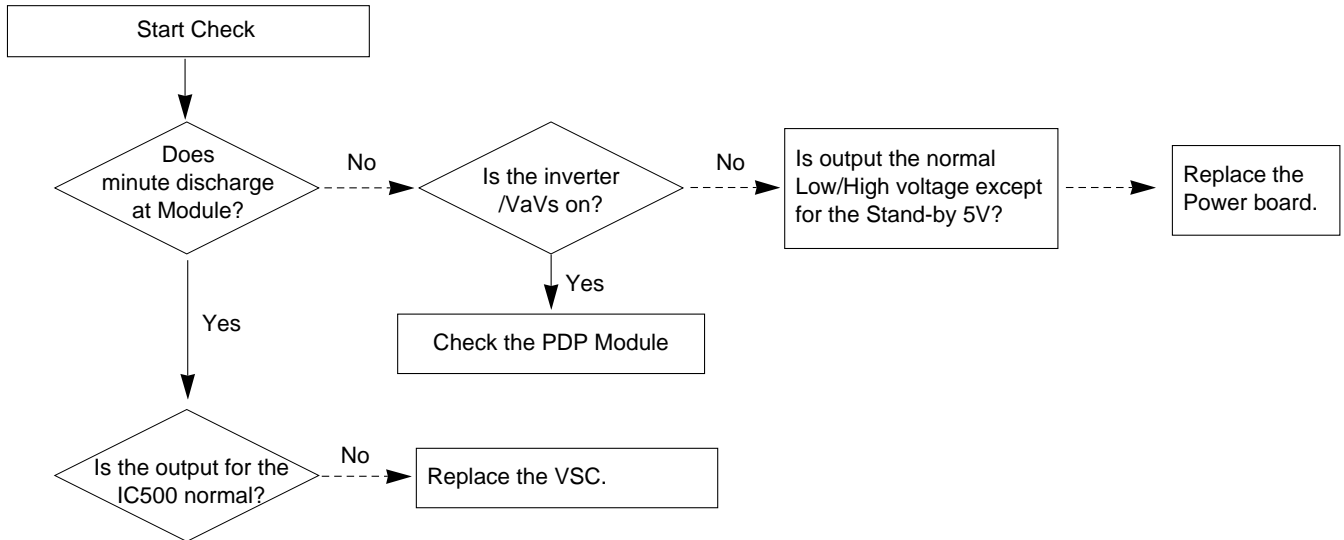

### 4. In the case an unusual display in RF mode.

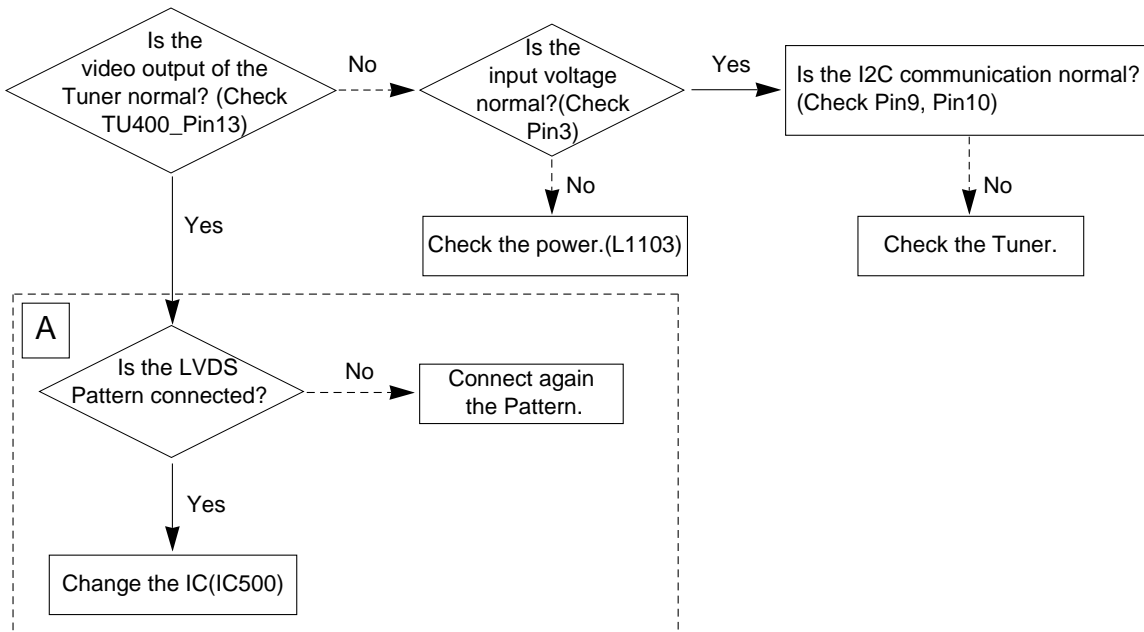

**5. In the case of an unusual display in rear AV mode.**

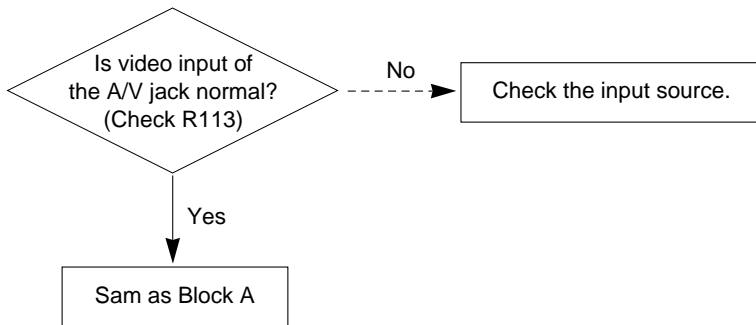

**8. In the case of an unusual display in SCART 1 mode.**

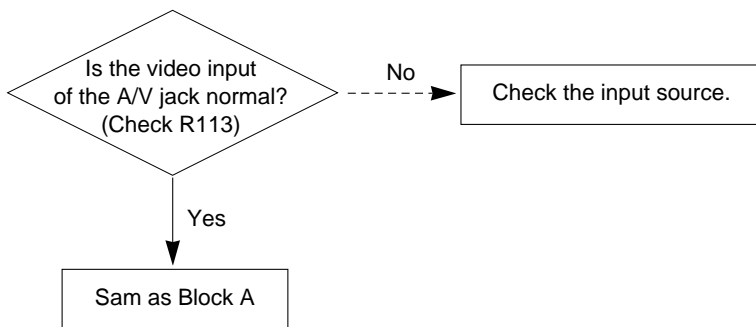

**9. In the case of an unusual display in SCART 1\_RGB mode.**

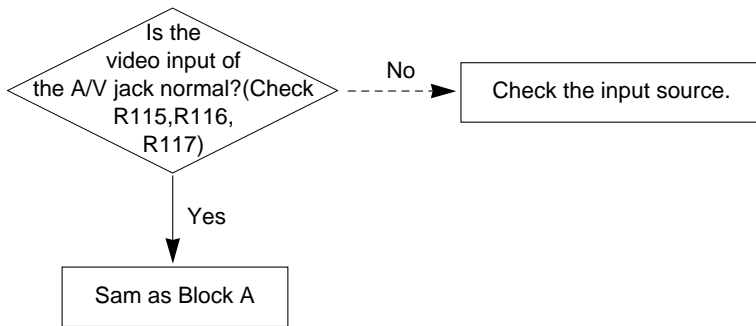

**10. In the case of an unusual display in SCART 2 mode.**

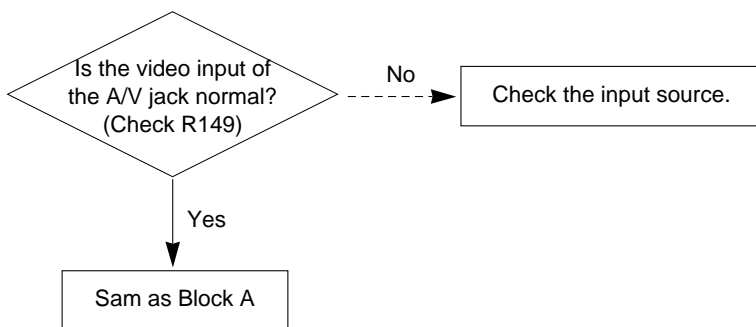



### 11. In the case of an unusual display in component 1 mode.

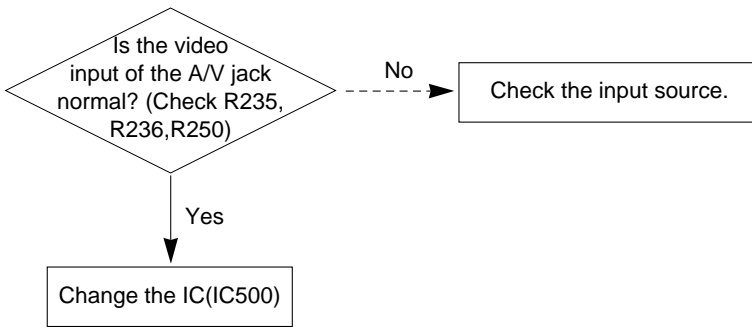

### 12. In the case of an unusual display in component 2 mode.

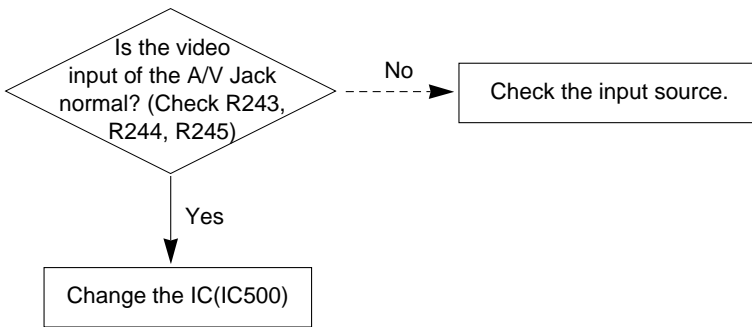

### 13. In the case of an unusual display in RGB mode.

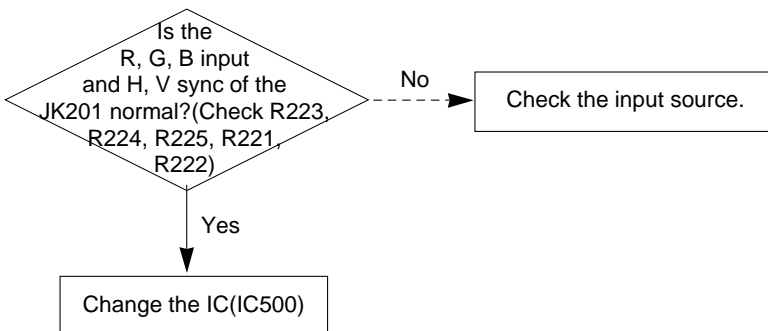

# 14. No Sound

## (1) Symptom

- 1) LED is green.
- 2) There is a picture but no sound.

## (2) Follow check

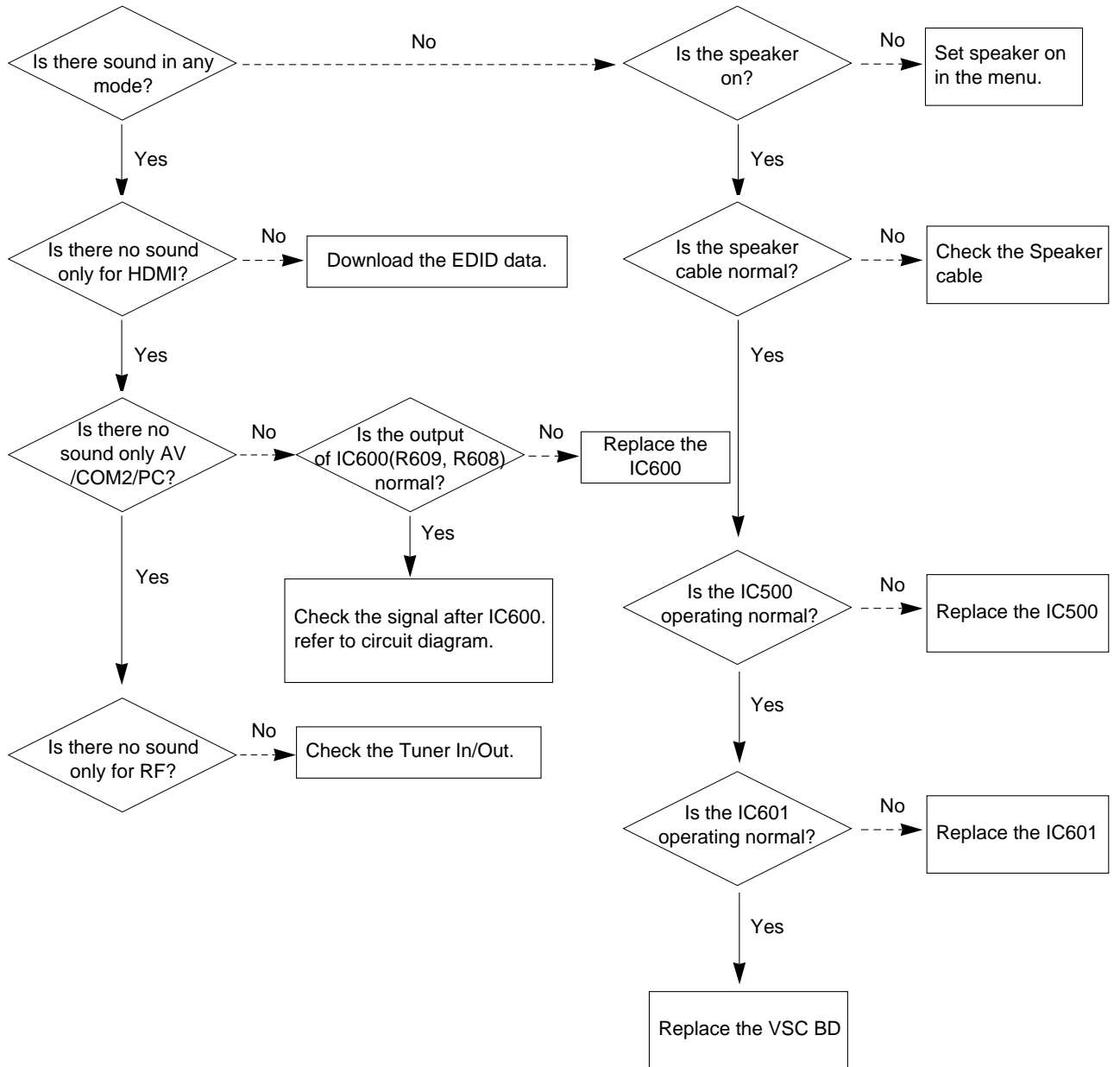

# 15. HDMI mode

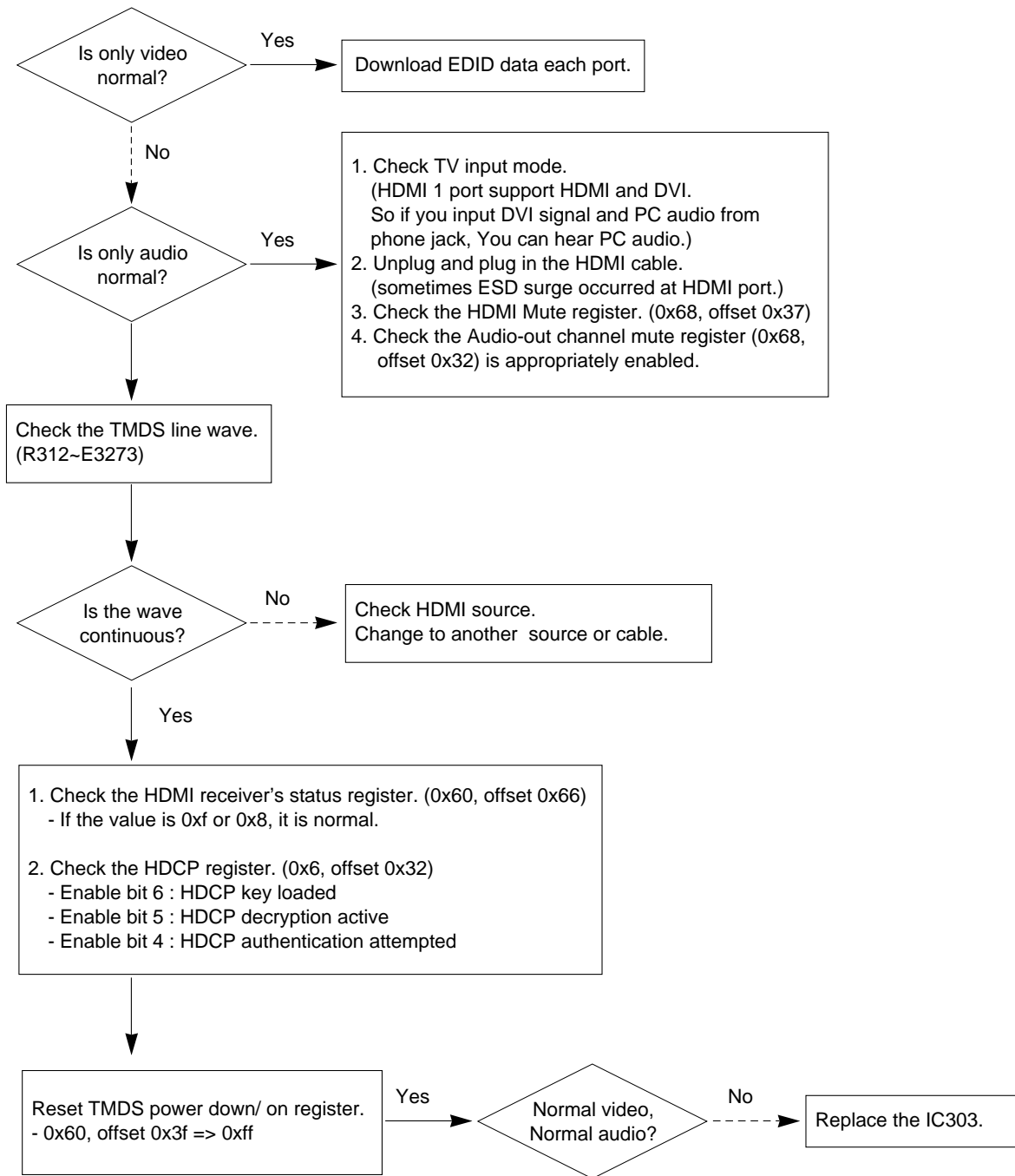

# BLOCK DIAGRAM

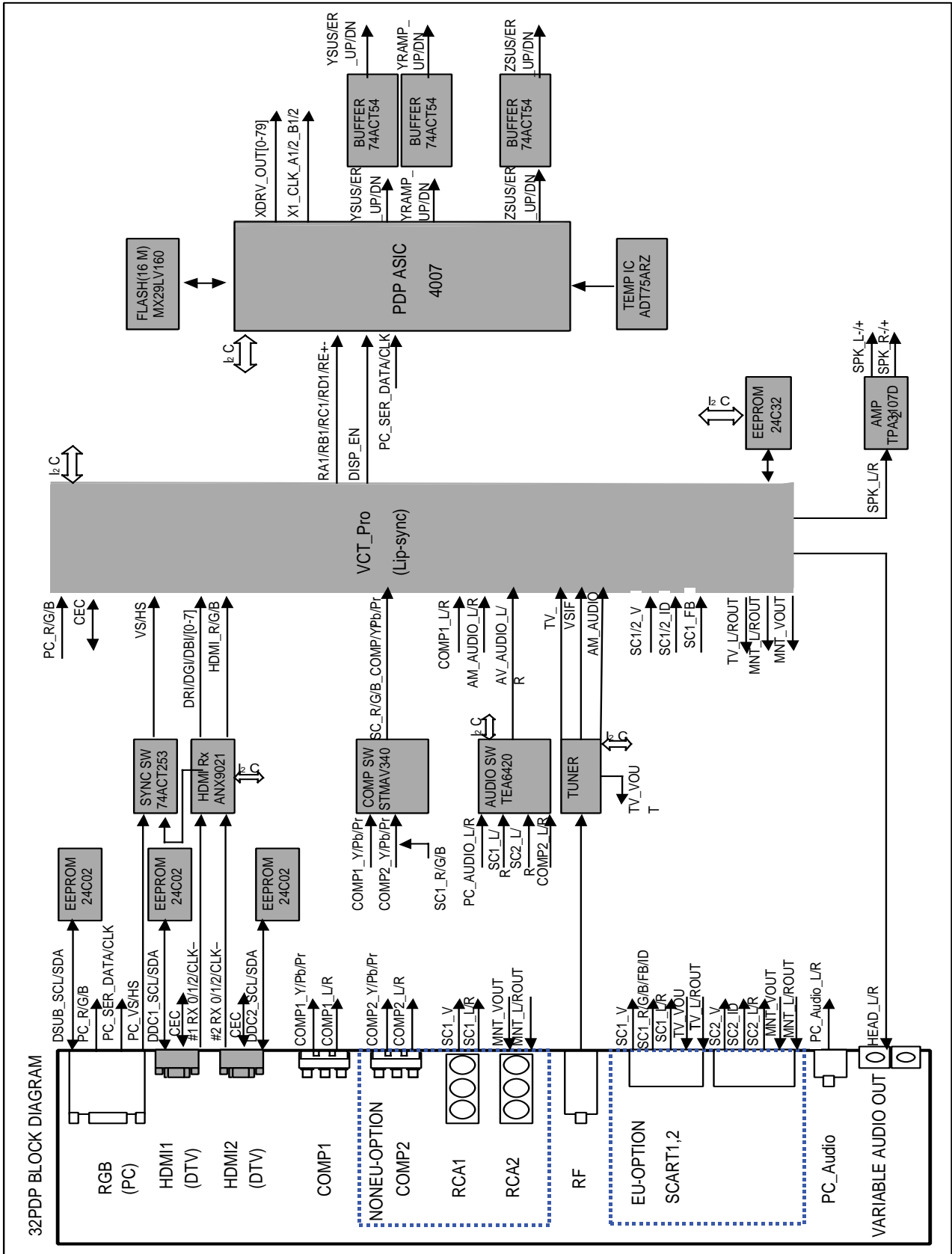

# EXPLODED VIEW

## IMPORTANT SAFETY NOTICE

Many electrical and mechanical parts in this chassis have special safety-related characteristics. These parts are identified by  $\Delta$  in the Schematic Diagram and EXPLODED VIEW. It is essential that these special safety parts should be replaced with the same components as recommended in this manual to prevent X-RADIATION, Shock, Fire, or other Hazards. Do not modify the original design without permission of manufacturer.

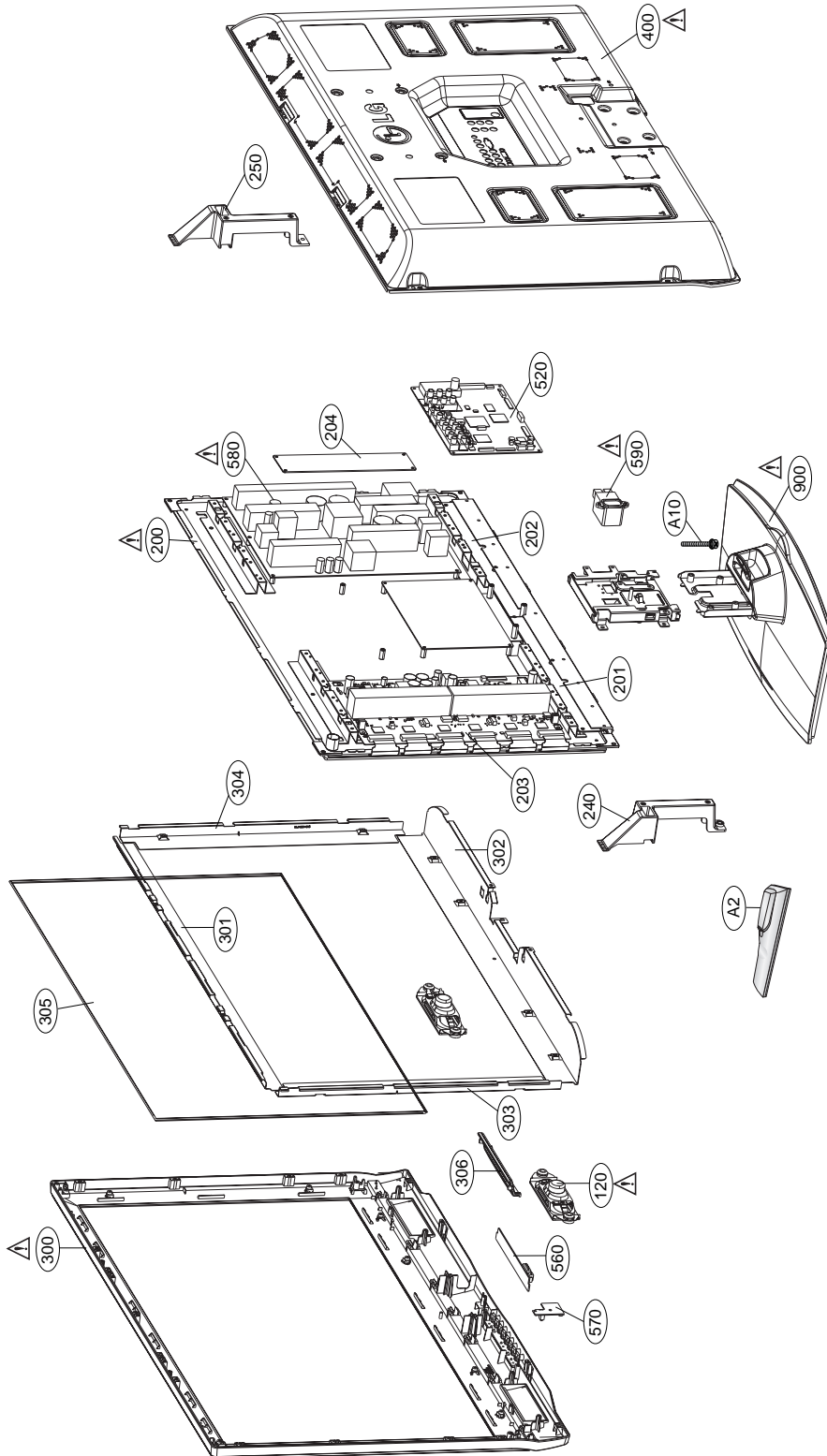

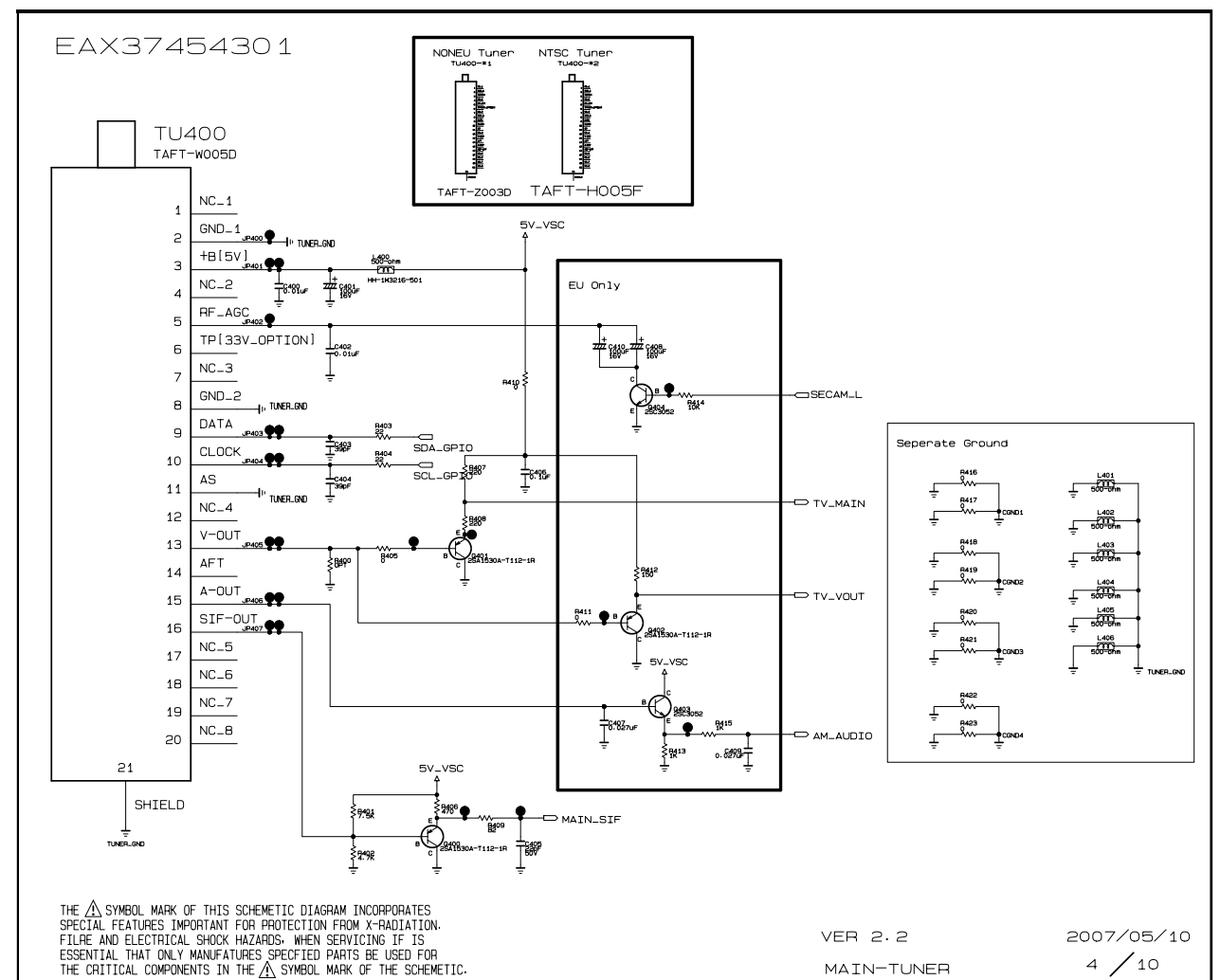
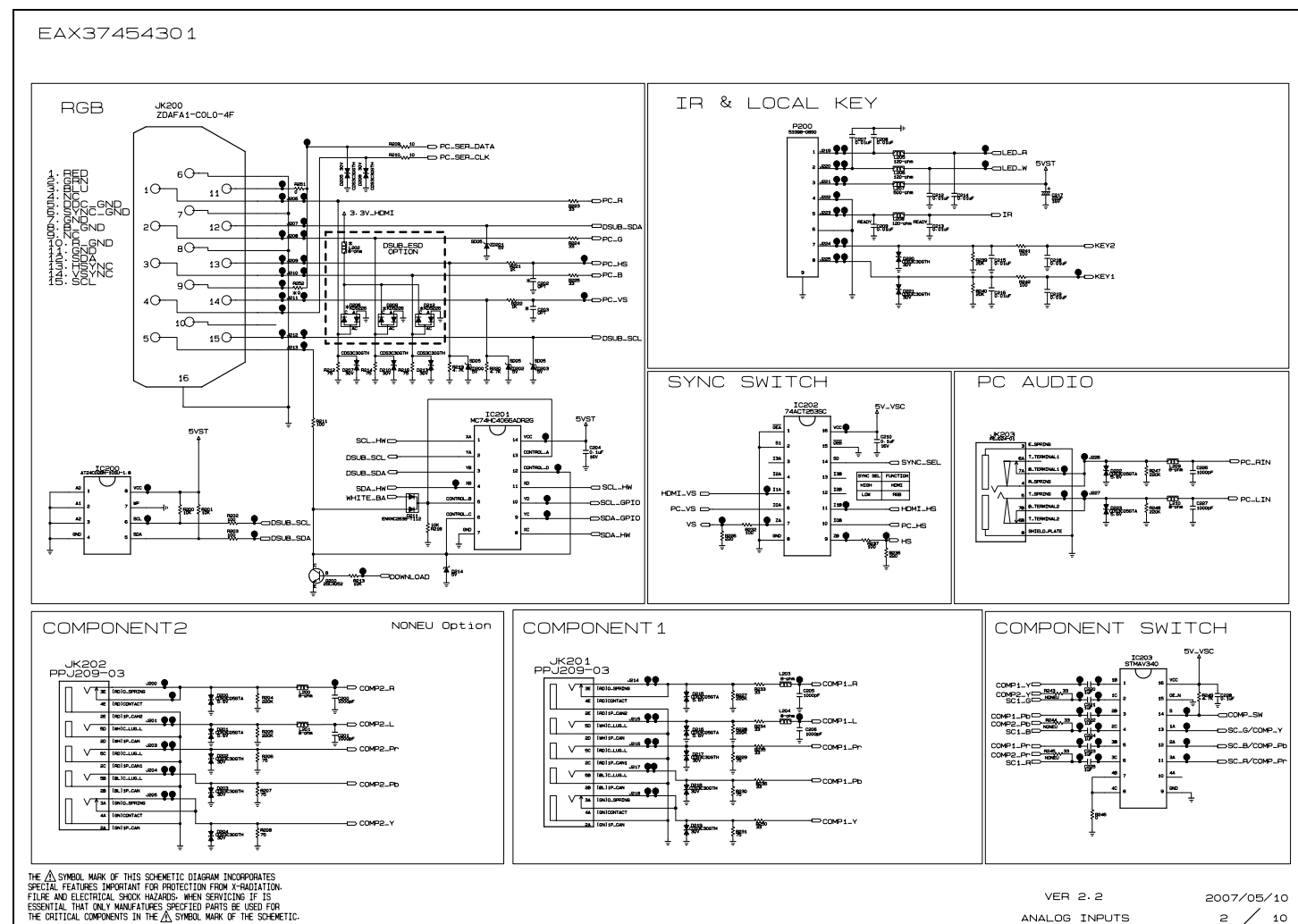
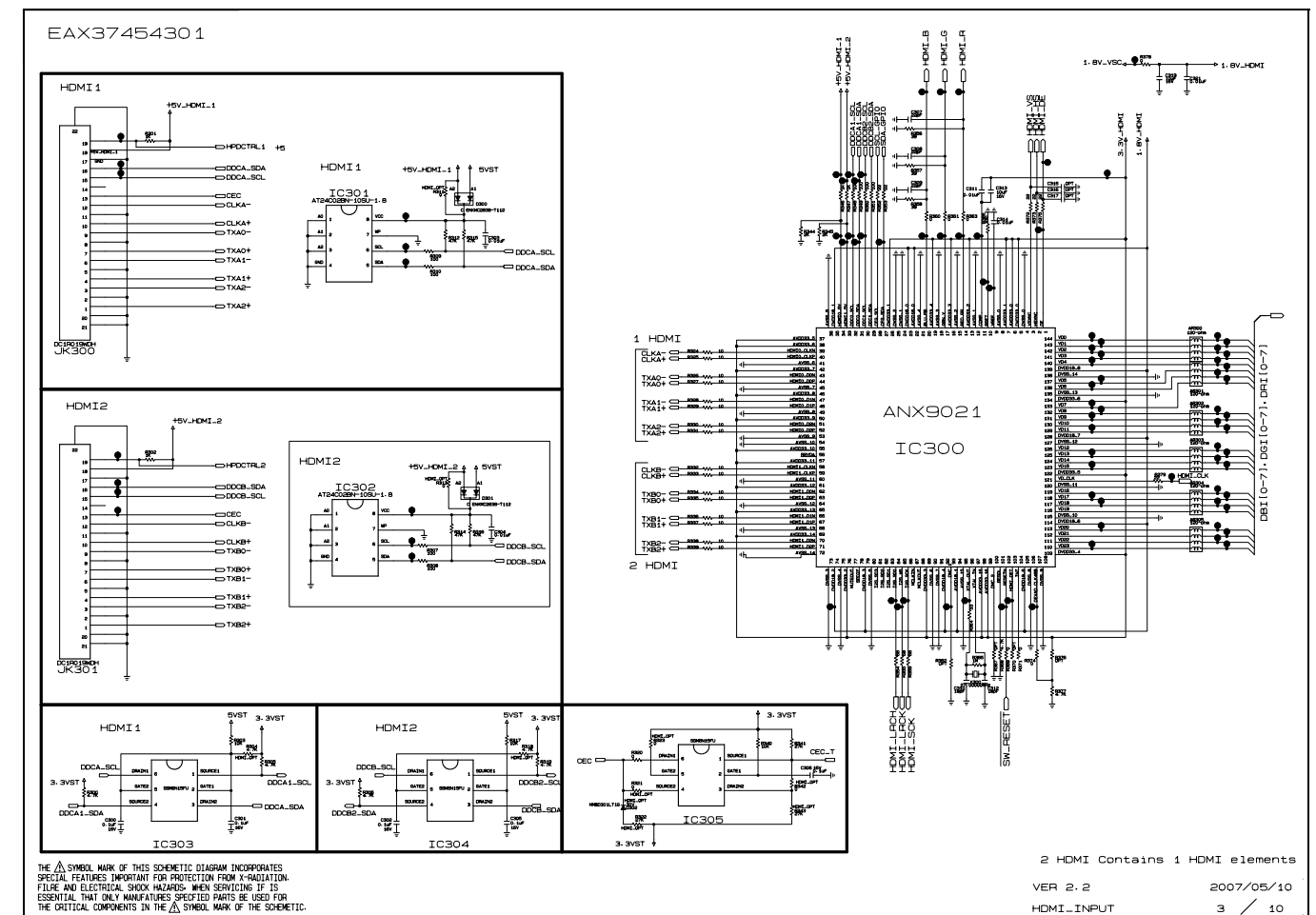
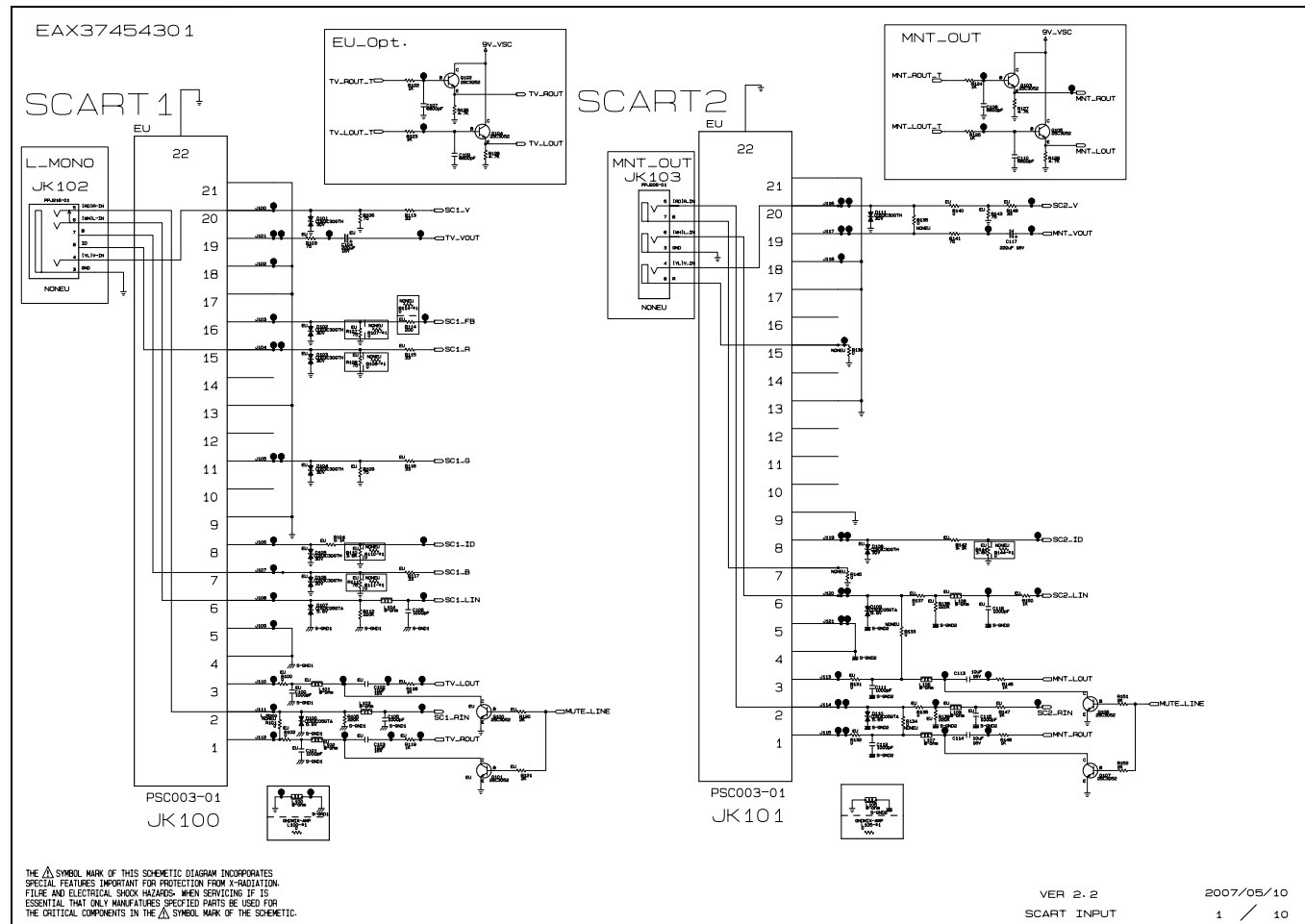

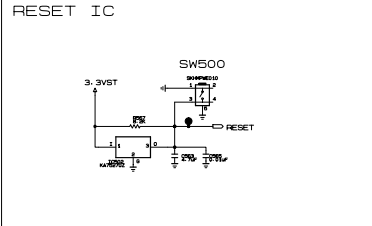
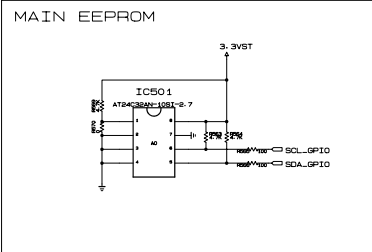
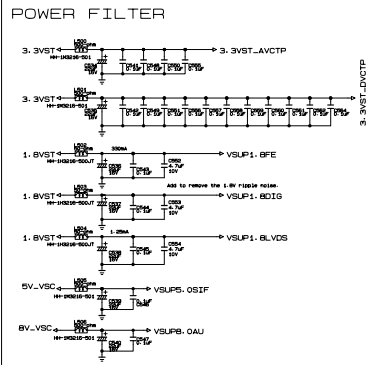
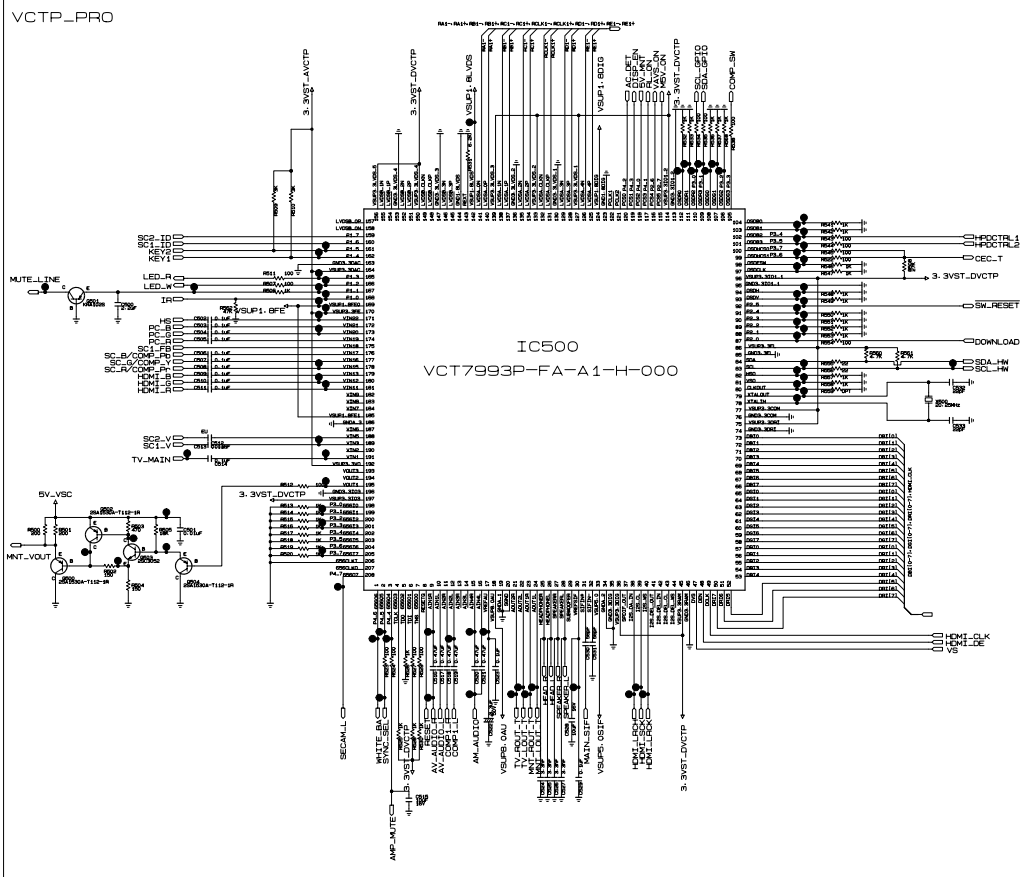

THE  $\Delta$  SYMBOL MARK OF THIS SCHEMATIC DIAGRAM INCORPORATES SPECIAL FEATURES IMPORTANT FOR PROTECTION FROM X-RADIATION, FILTRATION AND ELECTRICAL SHOCK HAZARDS. WHEN SERVICING IT IS ESSENTIAL THAT ONLY MANUFACTURER SPECIFIED PARTS BE USED FOR THE CRITICAL COMPONENTS IN THE  $\Delta$  SYMBOL MARK OF THE SCHEMATIC.

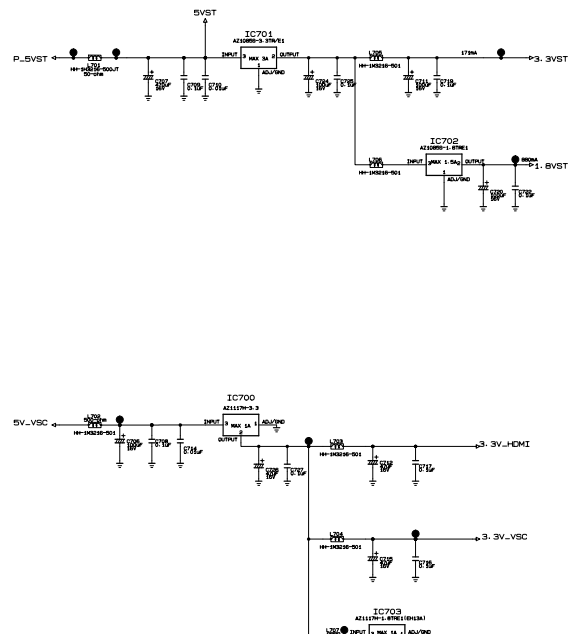
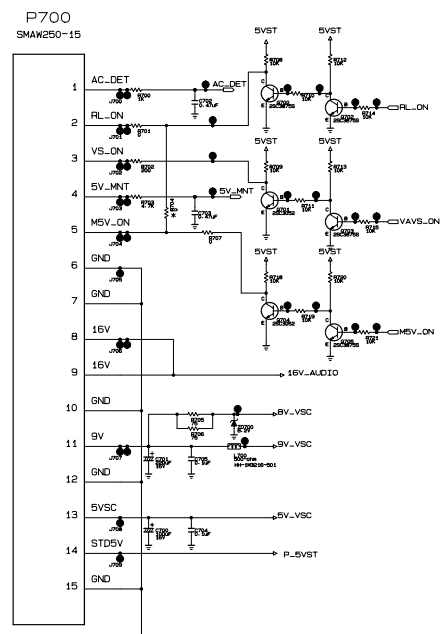

THE  $\Delta$  SYMBOL MARK OF THIS SCHEMATIC DIAGRAM INCORPORATES SPECIAL FEATURES IMPORTANT FOR PROTECTION FROM X-RADIATION, FILTRATION AND ELECTRICAL SHOCK HAZARDS. WHEN SERVICING IT IS ESSENTIAL THAT ONLY MANUFACTURER SPECIFIED PARTS BE USED FOR THE CRITICAL COMPONENTS IN THE  $\Delta$  SYMBOL MARK OF THE SCHEMATIC.

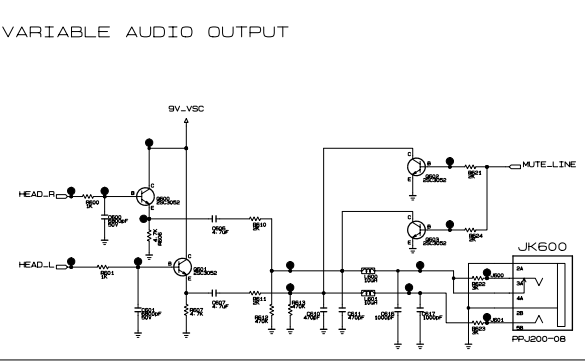
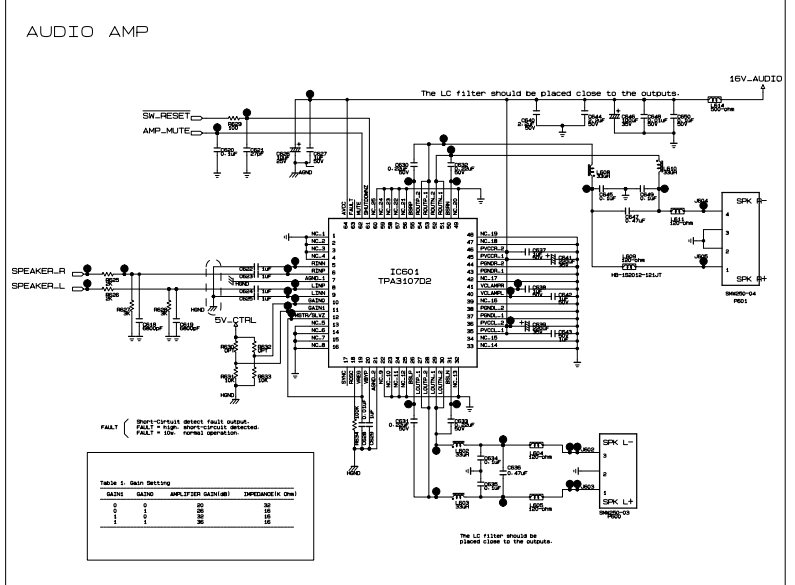
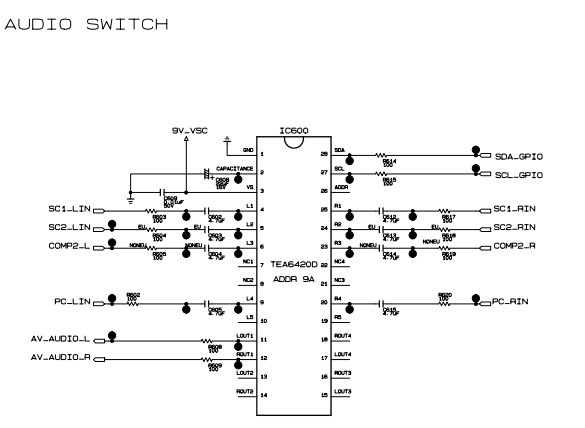

THE  $\Delta$  SYMBOL MARK OF THIS SCHEMATIC DIAGRAM INCORPORATES SPECIAL FEATURES IMPORTANT FOR PROTECTION FROM X-RADIATION, FILTRATION AND ELECTRICAL SHOCK HAZARDS. WHEN SERVICING IT IS ESSENTIAL THAT ONLY MANUFACTURER SPECIFIED PARTS BE USED FOR THE CRITICAL COMPONENTS IN THE  $\Delta$  SYMBOL MARK OF THE SCHEMATIC.

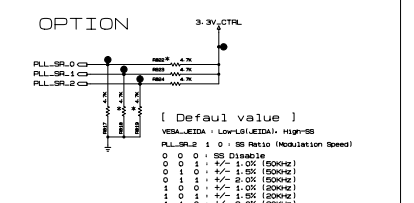
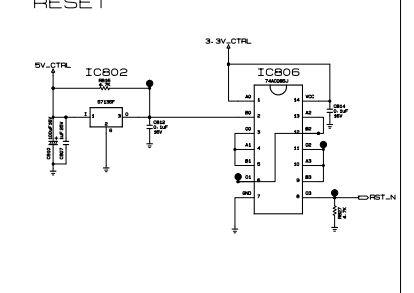
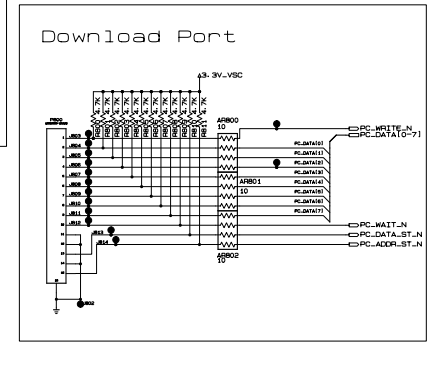
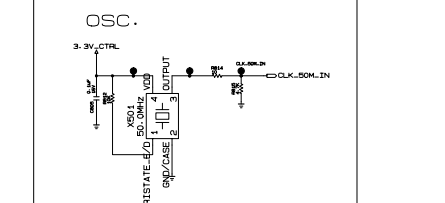
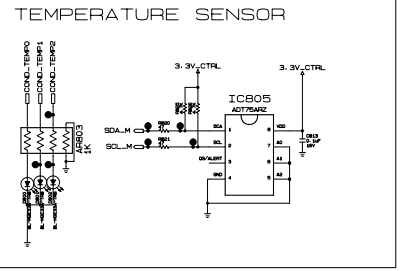
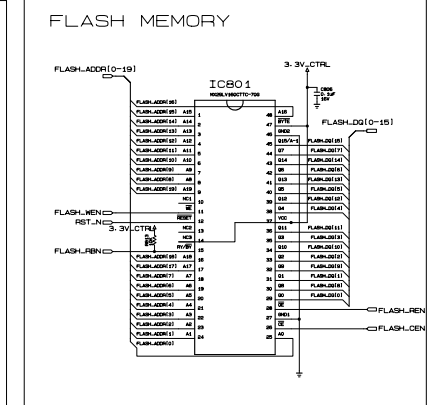
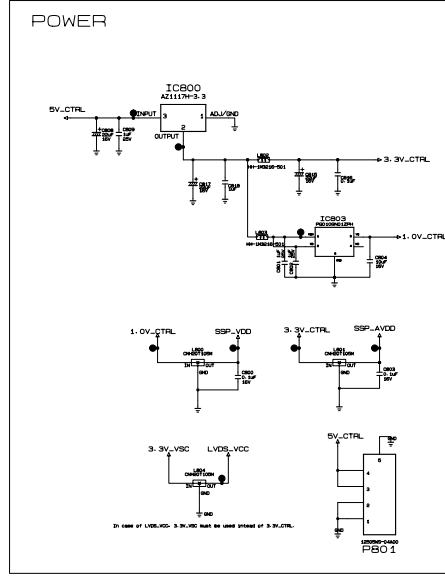

THE  $\Delta$  SYMBOL MARK OF THIS SCHEMATIC DIAGRAM INCORPORATES SPECIAL FEATURES IMPORTANT FOR PROTECTION FROM X-RADIATION, FILTRATION AND ELECTRICAL SHOCK HAZARDS. WHEN SERVICING IT IS ESSENTIAL THAT ONLY MANUFACTURER SPECIFIED PARTS BE USED FOR THE CRITICAL COMPONENTS IN THE  $\Delta$  SYMBOL MARK OF THE SCHEMATIC.









P/NO : MFL40431018

Oct., 2008  
Printed in Korea

