

4.2 DISASSEMBLY PROCEDURES

[TOP](#) [PREVIOUS](#) [NEXT](#)

Flow-Chart for Disassembly Procedure

No.	Item / Part	Fig.	Removal (Screw,Connector,Flex. & Other)
1	MF / Hood Unit	Fig. D2	Open the Flash 1-Screw (A), 1-Screw (B), 1-Screw (C) MF/Hood Unit
2	Side Case (R) Unit / LCD Unit	Fig. D3	2-Screws (D)
		Fig. D4	2-Screws (E)
		Fig. D5	Open the LCD, Tilt up the EVF 2-Screws (F), 1-Screw (G), 1-Screw (H), 1-Screw (I), 1-Screw (J)
		Fig. D6	1-Screw (K) 2-Connectors FP3401, FP6503 Side Case (R) Unit / LCD Unit
3	Lens Unit	Fig. D7	1-Screw (L) 2-Connectors FS201, FP701 Lens Unit
4	Front Unit	Fig. D8	2-Screws (M), 1-Screw (N) 2-Connectors FP4002, FP6005 Front Unit
5	EVF Unit, Sub C.B.A.	Fig. D9	1-Screw (O) 2-Connectors FP603, FP3402 EVF Unit, Sub C.B.A.
6	Rear Operation Unit	Fig. D10	Open the Rear Jack Cover 1-Screw (P), 1-Screw (Q), 1-Screw (R)
		Fig. D11	2-Connectors FP1001, FP6502 Rear Operation Unit
7	Main C.B.A.	Fig. D12	1-Screw (S) 7-Connectors FP2201, FP2202, FP2203, FP2204, FP5001, FP6501, FP6504 4-Tabs Main C.B.A.
8	Mecha. Unit	Fig. D13	Open the Cassette Cover 3-Screws (T) Mecha. Unit, Side Case (L) Unit
9	Jack C.B.A.	Fig. D14	2-Screws (U), 1-Screw (V) Jack C.B.A.
10	Front C.B.A.	Fig. D15	2-Screws (W) 1-Connector FP6402 Jack Barrier, Front C.B.A.
11	Monitor C.B.A.	Fig. D16	3-Screws (X), 1-Screw (Y), 1-Screw (Z) Rear Cover
		Fig. D17	Turning the LCD Unit 1-Screw (a), 1-Screw (b) LCD Unit, Camera Operation Flex.
		Fig. D18	2-Screws (c), 2-Screws (d) 6-Tabs LCD Case (Upper) Unit 2-Connectors FP901, FP902 1-Screw (e) 3-Tabs 2-Soldering Portions LCD Hinge Unit, Monitor C.B.A.
12	EVF C.B.A.	Fig. D19	2-Screws (f) 1-Tab EVF Unit, EVF View ADJ. Unit

<p>Fig. D20</p>	<p>Remove a,b,c,d department (remove a,b department previously). EVF Case (Upper) Remove e,f department. EVF Case (Lower)</p>
<p>Fig. D21</p>	<p>2-Tabs 2-Connectors FP801, FP802 EVF C.B.A.</p>

Fig. D1

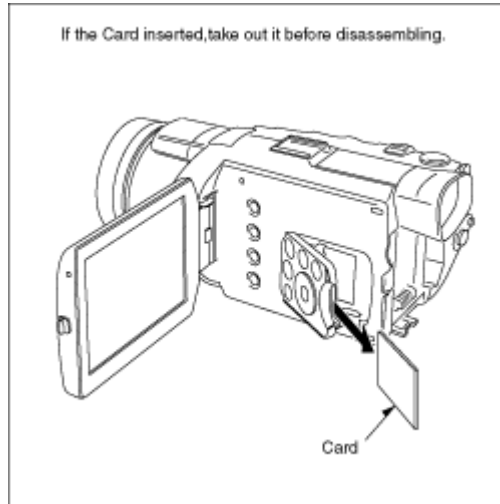

Fig. D2

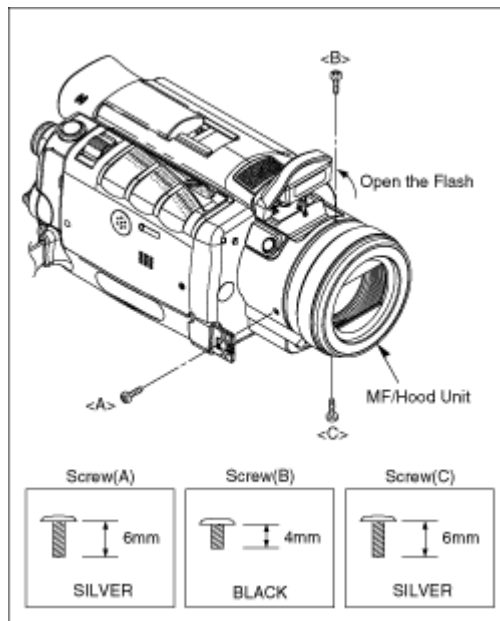

Fig. D3

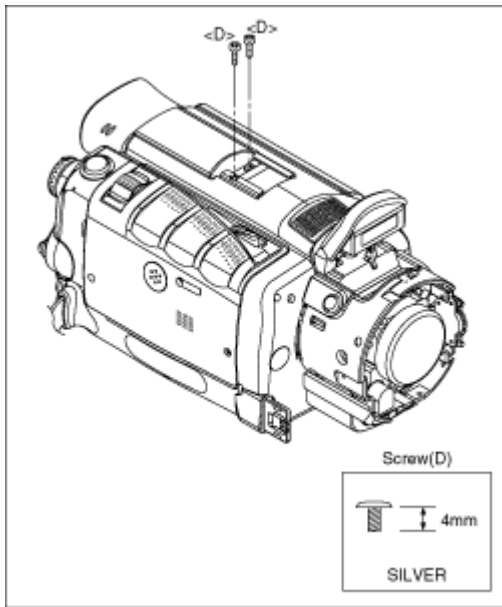

Fig. D4

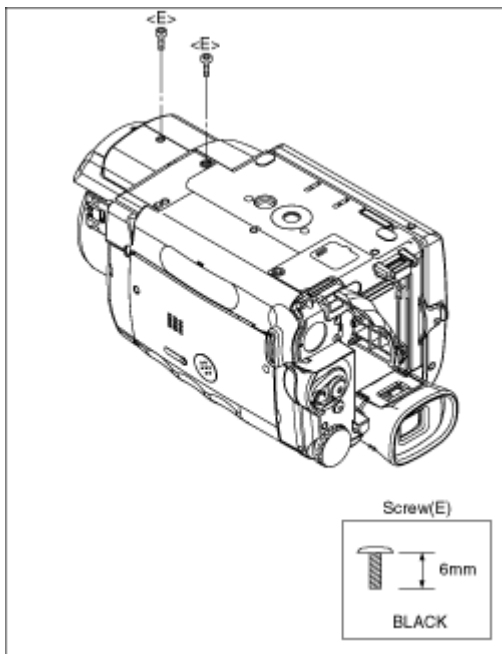

Fig. D5

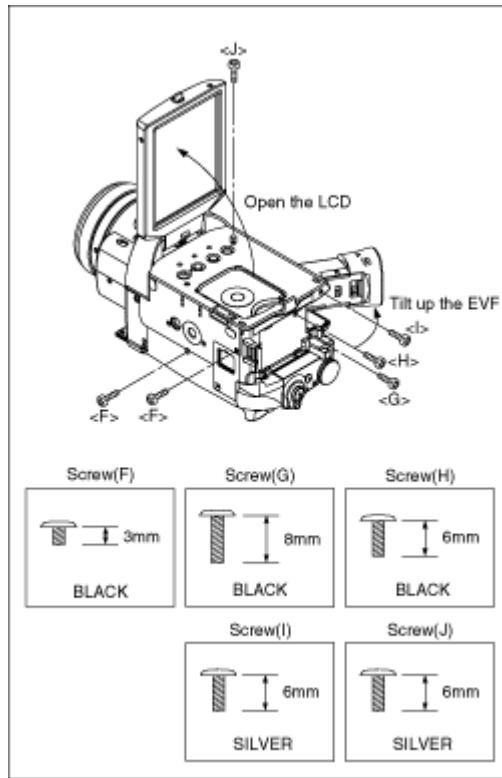

Fig. D6

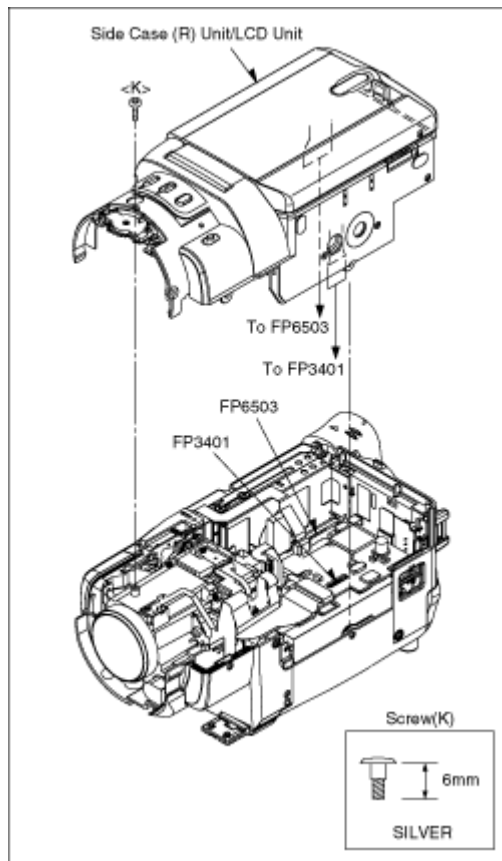

Fig. D7

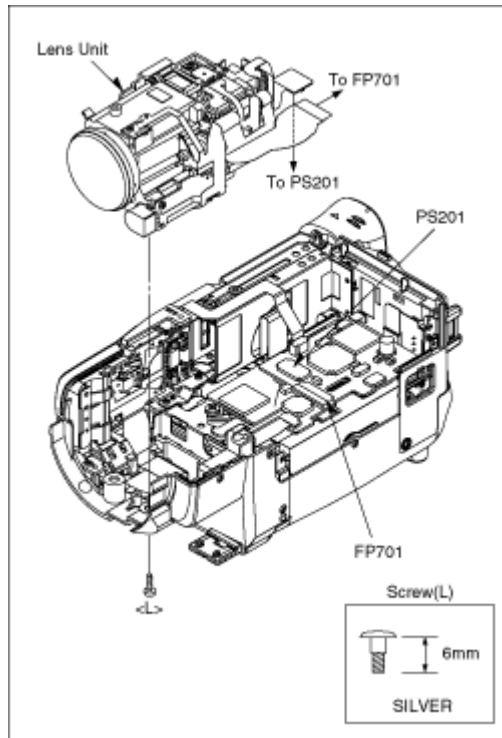

Fig. D8

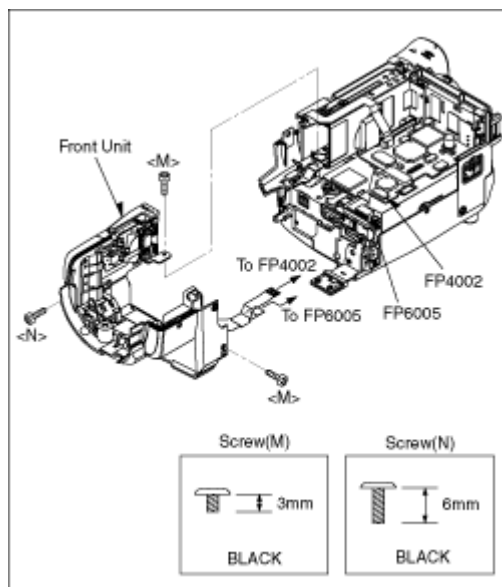

Fig. D9

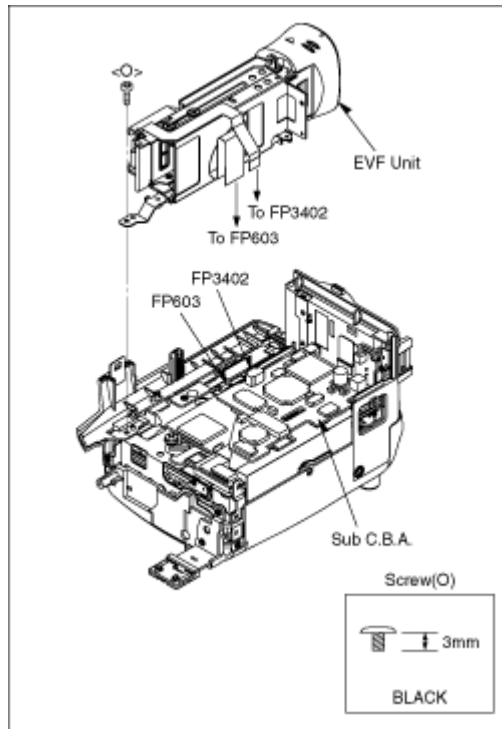

Fig. D10

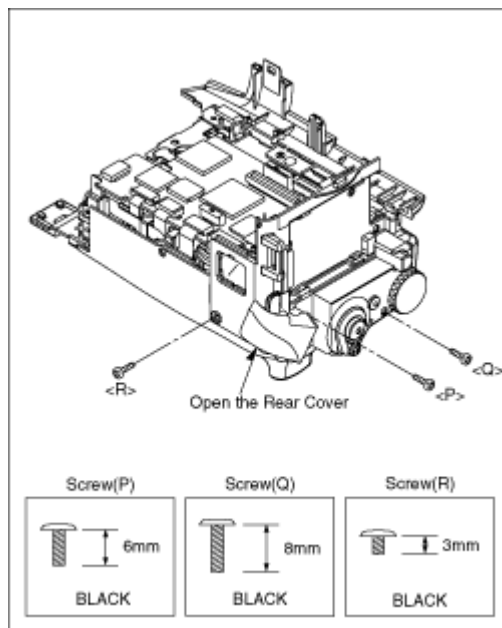

Fig. D11

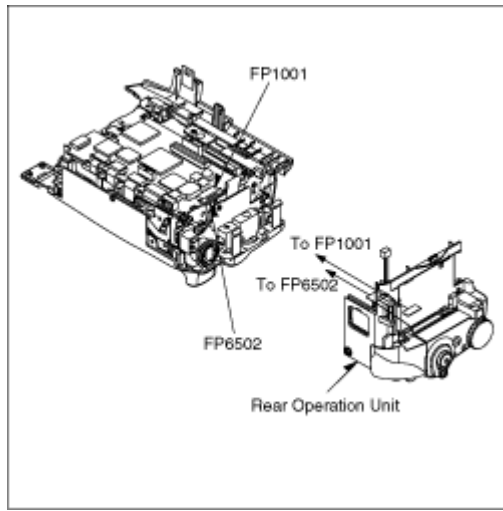

Fig. D12

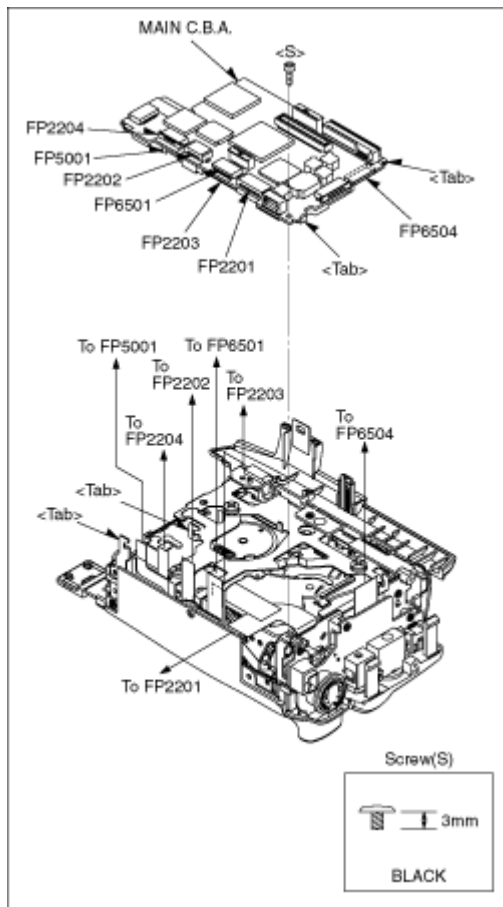

Fig. D13

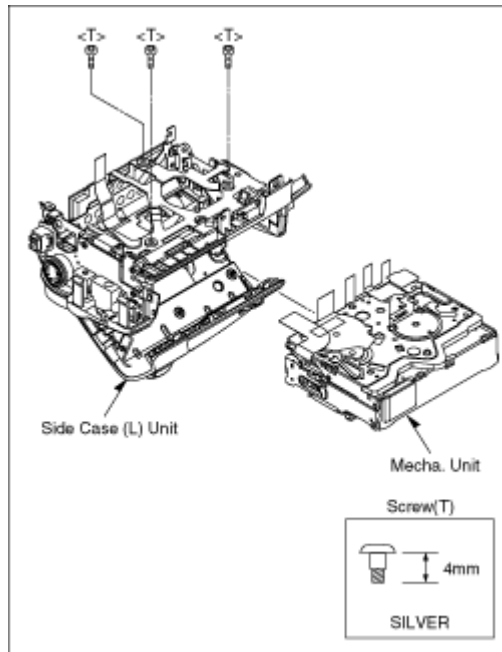

Fig. D14

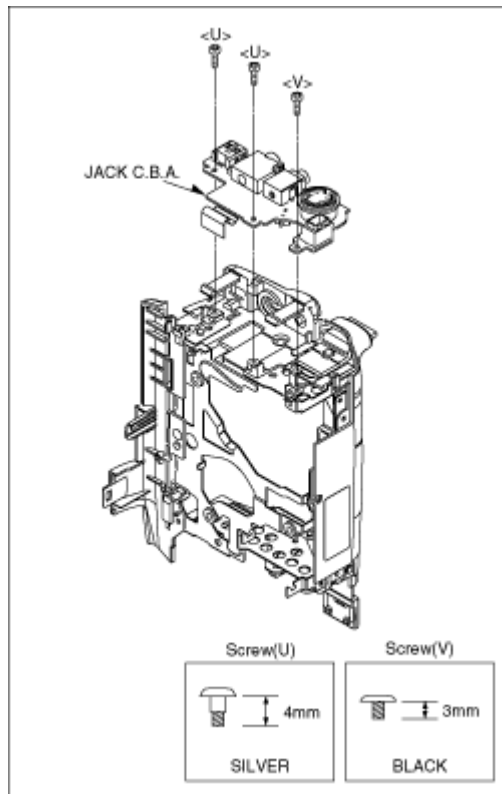

Fig. D15

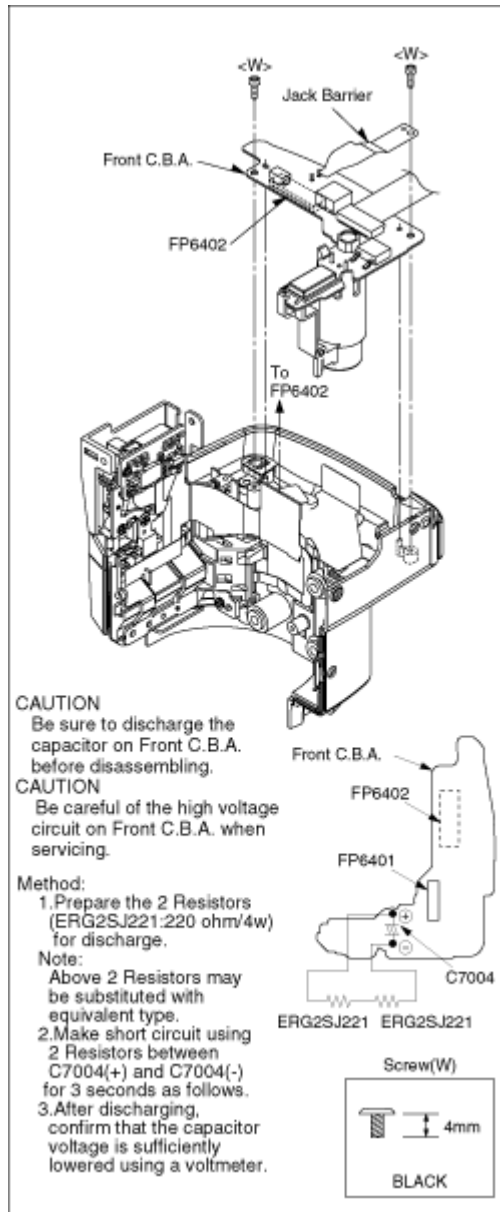

Fig. D16

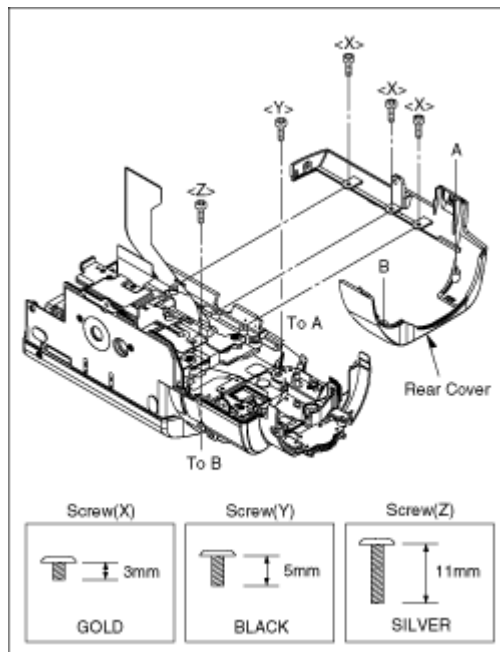

Fig. D17

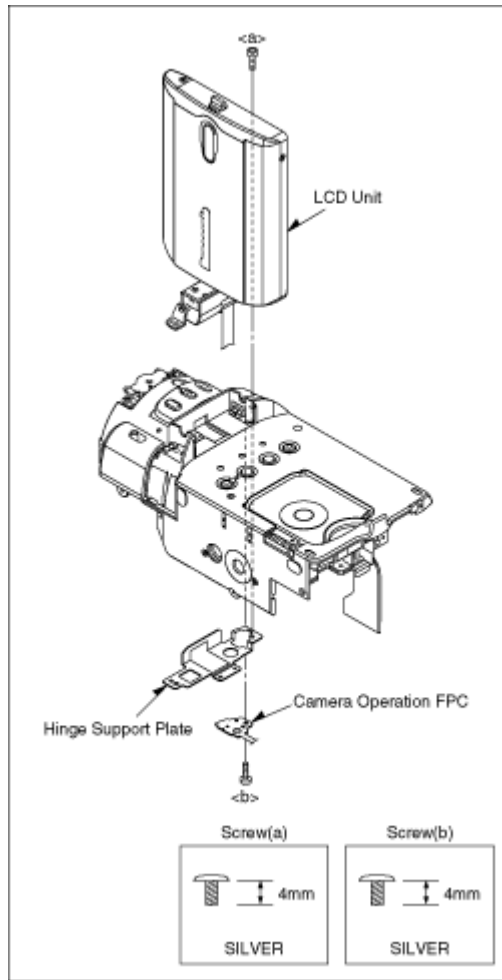

Fig. D18

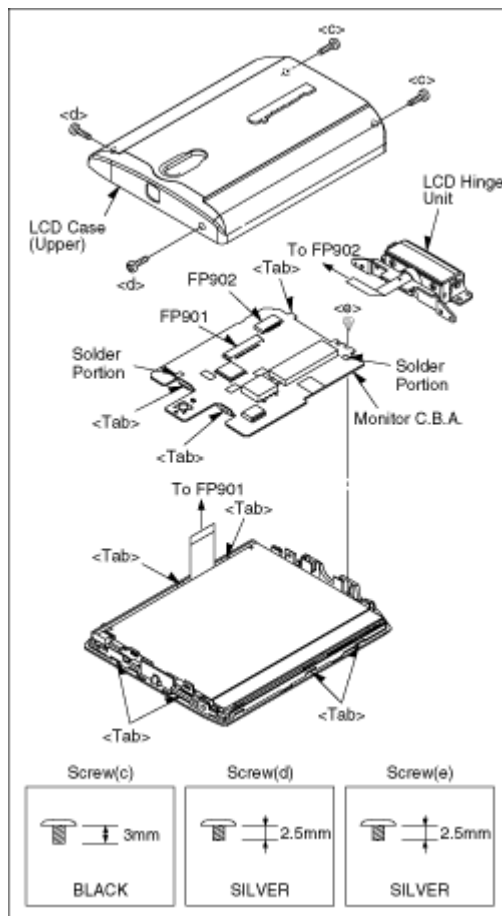

Fig. D19

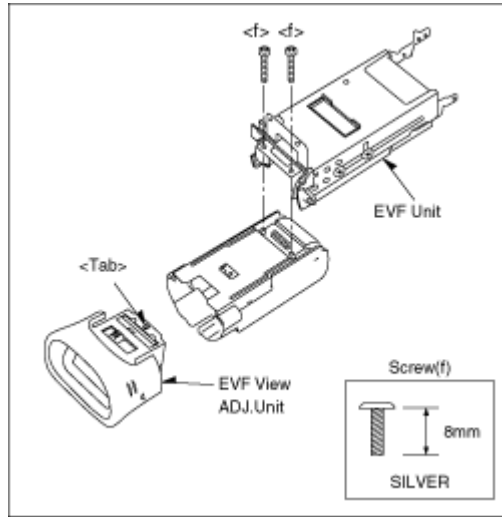

Fig. D20

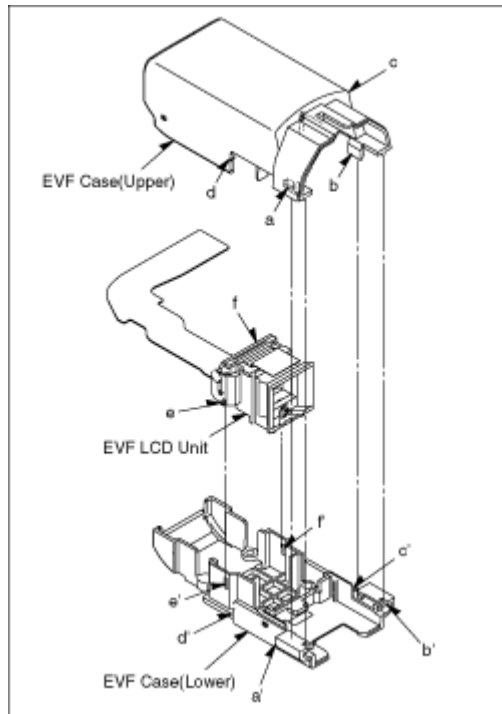
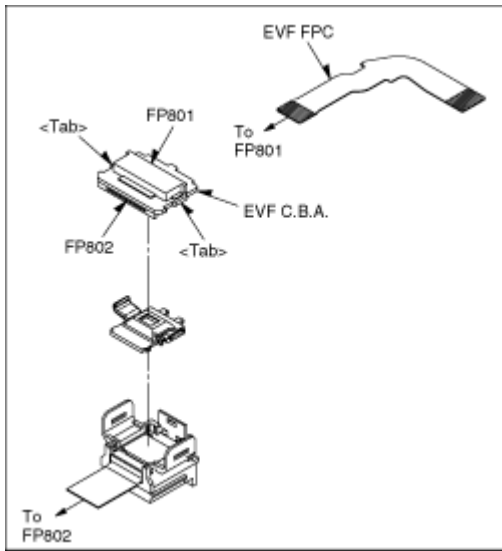

Fig. D21



[TOP](#) [PREVIOUS](#) [NEXT](#)