

Service Manual

ViewSonic VA1912W/Wb

Model No. VS10866

19" Color TFT LCD Display

(VA1912W/Wb_SM Rev. 1a Oct. 2005)

I. Copyright

Copyright © 2005 by ViewSonic Corporation. All rights reserved. No part of this publication may be reproduced, transmitted, transcribed, stored in a retrieval system, or translated into any language or computer language, in any form or by any means, electronic, mechanical, magnetic, optical, chemical, manual or otherwise, without the prior written permission of ViewSonic Corporation.

Disclaimer

ViewSonic makes no representations or warranties, either expressed or implied, with respect to the contents hereof and specifically disclaims any warranty of merchantability or fitness for any particular purpose. Further, ViewSonic reserves the right to revise this publication and to make changes from time to time in the contents hereof without obligation of ViewSonic to notify any person of such revision or changes.

Trademarks

Optiquest is a registered trademark of ViewSonic Corporation.

ViewSonic is a registered trademark of ViewSonic Corporation.

All other trademarks used within this document are the property of their respective owners.

Revision History

Revision	SM Editing Date	ECR Number	Description of Changes	Editor
1a	10/25/05		Initial Release	G. Han

TABLE OF CONTENTS

1. Precautions and Safety Notices	1
2. Specification	5
3. Front Panel Function Control Description	9
4. Circuit Description	15
5. Adjustment Procedure	17
6. Troubleshooting Flow Chart	40
7. Recommended Spare Parts List	48
8. Exploded Diagram and Exploded Parts List	53
9. Block Diagram	55
10. Schematic Diagrams	56
11. PCB Layout Diagrams	66

1. Precautions and Safety Notices

1. Appropriate Operation

- (1) Turn off the product before cleaning.
- (2) Use only a dry soft cloth when cleaning the LCD panel surface.
- (3) Use a soft cloth soaked with mild detergent to clean the display housing.
- (4) Use only a high quality, safety approved AC/DC power cord.
- (5) Disconnect the power plug from the AC outlet if the product will not be used for a long period of time.
- (6) If smoke, abnormal noise, or strange odor is present, immediately switch the LCD display off.
- (7) Do not touch the LCD panel surface with sharp or hard objects.
- (8) Do not place heavy objects on the LCD display, video cable, or power cord.
- (9) Do not use abrasive cleaners, waxes or solvents for your cleaning.
- (10) Do not operate the product under the following conditions:
 - Extremely hot, cold or humid environment.
 - Areas containing excessive dust and dirt.
 - Near any appliance generating a strong magnetic field.
 - In direct sunlight.

2. Caution

No modification of any circuit should be attempted. Service work should only be performed after you are thoroughly familiar with all of the following safety checks and servicing guidelines.

3. Safety Check









Care should be taken while servicing this LCD display. Because of the high voltage used in the inverter circuit, the voltage is exposed in such areas as the associated transformer circuits.

4. LCD Module Handling Precautions

4.1 Handling Precautions

- (1) Since front polarizer is easily damaged, pay attention not to scratch it.
- (2) Be sure to turn off power supply when connecting or disconnecting input connector.
- (3) Wipe off water drops immediately. Long contact with water may cause discoloration or spots.
- (4) When the panel surface is soiled, wipe it with absorbent cotton or other soft cloth.
- (5) Since the panel is made of glass, it may break or crack if dropped or bumped on hard surface.
- (6) Since CMOS LSI is used in this module, take care of static electricity and ensure human earth when handling.
- (7) Do not open or modify the Module Assembly.
- (8) Do not press the reflector sheet at the back of the module in any direction.
- (9) In the event that a Module must be put back into the packing container slot after it was taken out of the container, do not press the center of the CCFL Reflector edge. Instead, press at the far ends of the CFL Reflector edge softly. Otherwise the TFT Module may be damaged.
- (10) At the insertion or removal of the Signal Interface Connector, be sure not to rotate or tilt the Interface Connector of the TFT Module.

- (11) After installation of the TFT Module into an enclosure (LCD monitor housing, for example), do not twist or bend the TFT Module even momentarily. When designing the enclosure, it should be taken into consideration that no bending/twisting forces may be applied to the TFT Module from outside. Otherwise the TFT Module may be damaged.
- (12) The cold cathode fluorescent lamp in the LCD contains a small amount of mercury. Please follow local ordinances or regulations for disposal.
- (13) The LCD module contains a small amount of materials having no flammability grade. The LCD module should be supplied with power that complies with the requirements of Limited Power Source (IEC60950 or UL1950), or an exemption should be applied for.
- (14) The LCD module is designed so that the CCFL in it is supplied by a Limited Current Circuit (IEC60950 or UL1950). Do not connect the CCFL to a Hazardous Voltage Circuit

Correct methods :	Incorrect Methods :
<p>Only touch the metal-frame of the panel or the front cover of the monitor. Do not touch the surface of the polarizer .</p>	<p>Surface of the panel is pressed by fingers & this may cause “MURA”</p>
	
	
<p>Take out the monitor with cushion</p>	<p>Take out the monitor by grasping the LCD panel. That may cause “MURA”.</p>
	
<p>Place the monitor on a clean & soft foam pad .</p>	<p>Place the monitor on foreign objects . That could scratch the surface of panel</p>
	

2. Specification

2.1 INTRODUCTION

	FEATURES	VA1912w / VA1912wb
TFTLCD PANEL	Size	19" wide
	Luminance (Typ, cd/m ²)	280 cd/m ²
	Contrast Ratio (Typ)	500:1
	Colors (6 bit + 2 bit FRC)	16.2 M colors
	Response Time (Typ)	8 ms
	Viewing Angle (H/V)	150 ° / 130 °
	Recommend resolution	1440 x 900@60Hz
Input Signal	Analog (75ohms, 0.7/1.0 Vp-p)	Yes
	Digital	Yes
Sync Compatibility	Separate Sync	Yes
	Composite Sync	No
	Sync on Green	No
Compatibility	PC	Yes
	Power Mac	Yes
	TV Box (NextVision 6)	Yes
Power Voltage	AC 100-240V, 50/60Hz	Yes
Power Consumption	On Mode(Max / Typ)	36W(max) / 32W(typ)
	Active Off Mode (Max)	<1W
Audio	Amplifier/Speaker	1.5W/2.5W x2
Ergonomics	Tilt (20 ° to -5 °)	Yes
	Swivel	No
	Pivot	No
	Height Adjust	No
OSD Control	[X] [1] [▼] [▲] [2] [U]	Yes
Dimension	Physical (W x H x D mm)	451 x 391 x 197 (mm) 17.8 x 15.4 x 7.8 (in)
	Package (W x H x D mm)	538 x 470 x 158 (mm) 21.2 x 18.5 x 6.2 (in)
Weight	Physical (Net kg/lb)	4.5kg (9.9lb)
	Package (Gross Kg/lb)	5.7kg (12.5lb)
Operating Condition	Temperature (/)	41 -95 /+5 -+35
	Humidity (%)	20 % - 80 %
Storage Condition	Temperature (/)	-4 -131 /-20 -55
	Humidity (%)	20 % - 85 %
Regulation	CB / TCO99 / UL/cUL / FCC-B / ICES 003 / Argentina-TUV/S / NOM / EPA Energy Star / TUV/Ergo / ISO13406-2 / TUV/GS / CE / GOST-R / SASO / BSMI / PSB / C-Tick / Korea (MIC) / CCC	

2.2 GENERAL specification

Test Resolution & Frequency	1440 x 900 @ 60Hz
Test Image Size	Full Size
Contrast and Brightness Controls	Factory Default: Contrast = 70%, Brightness = 100%

2.3 VIDEO INTERFACE

Analog Input Connector	DB-15 (Analog), refer the appendix A
Digital Input Connector	N/A
Default Input Connector	Defaults to the first detected input
Video Cable Strain Relief	Equal to twice the weight of the monitor for five minutes
Video Cable Connector DB-15 Pin out	Compliant DDC 2B
Video Signals	1. Video RGB (Analog) 2. DVI (Digital) Separate
Video Impedance	75 Ohms (Analog)
Maximum PC Video Signal	950 mV with no damage to monitor
Maximum Mac Video Signal	1250 mV with no damage to monitor
Sync Signals	TTL
DDC 2B	Compliant with Revision 1.3
Sync Compatibility	Separate Sync
Video Compatibility	Shall be compatible with all PC type computers, Macintosh computers, and after market video cards
Resolution Compatibility	640 x 350*, 640 x 480, 720 x 400* (640 x 400*), 800 x 600, 832 x 624, 1024 x 768, 1152 x 864, 1280 x 768, 1280 x 960, 1280 x 1024, 1440 x 900 * The image vertical size might not be full screen. But the image vertical position should be at the center.
Exclusions	Not compatible with interlaced video

2.4 POWER SUPPLY

Power Supply (power build-in)	CMO Part Number: 27-D003247
Input Voltage Range	100 TO 240 VAC
Input Frequency Range	50 TO 60 HERTZ
Short Circuit Protection	Output can be shorted without damage
Over Current Protection	FUSE 3.15 A typical at 250 VAC
Leakage Current	75 mA (Max) at 240VAC / 50Hz
EFFICIENCY	80 % typical at 100VAC @ 60 Hert
Fuse	Internal and not user replaceable
Power Dissipation	<1 Watts
Max Input AC Current	1.6 Arms @ nominal range
INRUSH CURRENT (COLD START)	80 A @ 240VAC , 50Hz
Power Supply Cold Start	Shall start and function properly when under full load, with all combinations of input voltage, input frequency, and operating temperature
Power Supply Transient Immunity	Shall be able to withstand an EN61000-4-4 ±2KV transient test with no damage
Power Supply Line Surge Immunity	Shall be able to withstand ±2KV (L-L) and ±2.3KV (L-PE) with no damage
Power Supply Missing Cycle Immunity	Shall be able to function properly, without reset or visible screen artifacts, when ½ cycle of AC power is randomly missing at nominal input
Power Supply Acoustics	The power supply shall not produce audible noise that would be detectable by the user. Audible shall defined to be in compliance with ISO 7779 (DIN EN27779:1991) Noise measurements of machines acoustics. Power Switch noise shall not be considered

US Type Power Cable	Separate 3-prong NEMA 5-15P type plug. Length = 1.8m. Connects to display. Color = Black
European Type Power Cable	Schuko CEE7-7 type plug. Length = 1.8m, Connects to display. Color = Black
CCC Type Power Cable	Separate 3-prong type plug. Length = 1.8m. Connects to display. Color = Black
PSE Type Power Cable	Separate 2-prong NEMA 1-15P type plug. Length = 1.8m. Connects to display. Color = Black
Power Saving Operation(Method)	VESA DPMS Signaling
Power Consumption	ON Mode < 36 W (max) / 32 W (typ) ACTIVE OFF < 1 W
Recovery Time	ON MODE = N/A, ACTIVE OFF < 5 SEC

2.5 ELECTRICAL REQUIREMENT

Horizontal / Vertical Frequency

Horizontal Frequency	30 – 82 KHZ
Vertical Refresh Rate	50 – 85* HZ.
Maximum Pixel Clock	135 MHz (EDID file is 140MHz)
Sync Polarity	Independent of sync polarity.

Timing Table

Item	Timing	Analog	Digital
1	640 x 350 @ 70Hz, 31.5kHz	Yes	Yes
2	640 x 400 @ 60Hz, 31.5kHz	Yes*	Yes
3	640 x 400 @ 70Hz, 31.5kHz	Yes	Yes
4	640 x 480 @ 60Hz, 31.5kHz	Yes	Yes
5	640 x 480 @ 67Hz, 35.0kHz	Yes	Yes
6	640 x 480 @ 72Hz, 37.9kHz	Yes	Yes
7	640 x 480 @ 75Hz, 37.5kHz	Yes	Yes
8	640 x 480 @ 85Hz, 43.27kHz	Yes	Yes
9	720 x 400 @ 70Hz, 31.5kHz	Yes	Yes
10	800 x 600 @ 56Hz, 35.1kHz	Yes	Yes
11	800 x 600 @ 60Hz, 37.9kHz	Yes	Yes
12	800 x 600 @ 75Hz, 46.9kHz	Yes	Yes
13	800 x 600 @ 72Hz, 48.1kHz	Yes	Yes
14	800 x 600 @ 85Hz, 53.7kHz	Yes	Yes
15	832 x 624 @ 75Hz, 49.7kHz	Yes	Yes
16	1024 x 768 @ 60Hz, 48.4kHz	Yes	Yes
17	1024 x 768 @ 70Hz, 56.5kHz	Yes	Yes
18	1024 x 768 @ 72Hz, 58.1kHz	Yes	Yes
19	1024 x 768 @ 75Hz, 60.0kHz	Yes	Yes
20	1024 x 768 @ 85Hz, 68.67kHz	Yes	Yes
21	1152 x 864 @ 75Hz, 67.5kHz	Yes	Yes
22	1280 x 1024 @ 60Hz, 63.4kHz	Yes	Yes
23	1280 x 1024 @ 75Hz, 79.97kHz	Yes	No
24	1280x 768 @ 60Hz, 47.78kHz	Yes	Yes
25	1280 x 960 @ 60Hz, 60kHz	Yes	Yes
26	1440 x 900 @ 60Hz, 55.96kHz	Yes	Yes

*: The vertical image size might not be full screen.

2.6 FRONT PANEL CONTROLS AND INDICATORS

Front Panel Hardware Controls

Power Switch (Front Head)	Power Control, soft Power Switch.
Power LED (Front Head)	Green – ON Orange – Active Off Dark = Soft Power Switch OFF
Front Panel Controls (Head) [X] [1] [▼] [▲] [2] [⏻]	[⏻] Power [1] Button 1 [2] Button 2 [▲] Up arrow button [▼] Down arrow button [X] AUDIO MUTE ON/OFF Note: Power Button, Button 1 and Button 2 and Mute Button must be one-shot logic operation. (i.e. there should be no cycling)
Reaction Time	OSD must fully appear within 0.5s after pushing Button 1

Short Cuts Function from the button(s)

[1]	Main Menu
[2]	Input toggle (Analog or Digital)
[▼] or [▲]	To immediately activate Contrast menu. It should be change to Brightness OSD by push button [2]
[▼] + [▲]	Recall both of Contrast and Brightness to default
[1] + [2]	Toggle 720x400 and 640x400 mode when input 720x400 or 640x400 mode
[1] + [▼] + [▲]	White Balance. (Not shown on user's guide)
[1] + [▼]	Power Lock
[1] + [▲]	OSD Lock
[X]	Audio Mute on /off
Remark : All the short cuts function are only available while OSD off	

Function descriptions

OSD Lock short cuts function for the buttons

The OSD lock will be activated by pressing the front panel control buttons "(1), & (▲)" for 10 seconds. If the user then tries to access the OSD by pressing any of the buttons "1", "▼", "▲", "2" a message will appear on the screen for 3 seconds showing "OSD Locked". The OSD lock will be deactivated by pressing the front panel control buttons "(1), & (▲)" again for 10 seconds.

Note1: When the OSD is locked will lock all functions, including "Volume" and "Mute"

Note 2: Status bar indicating OSD Lock or Unlock is in progress and when complete it will indicate "OSD Locked"

Note 3: OSD Lock should not lock Power Button and Power Lock function

Power Lock short cuts function for the buttons

The power button lock will be activated by pressing the front panel control buttons "(1), & (▼)" for 10 seconds. Locking the power button means that the user won't be able to turn off the LCD while the power button is locked. If the user presses the power button while it is locked, a message will appear on the screen for 3 seconds showing "Power Button Locked". It also means that with the power button locked, the LCD would automatically turn back "On" when power is restored after a power failure. If the power button is not in the locked mode, then power should return to it's previous state when power is restored after a power failure. The power button lock will be deactivated by pressing the front panel control buttons "(1), & (▼)" again for 10 seconds.

Note 1: Status bar indicating Power Button lock or unlock is in progress and when complete it will indicate "Power Button Locked"

Note 2: Power should only be lockable in the "On State"

<p>Memory Recall Actions</p> <p>Memory Recall action on the analog and digital mode as below</p> <ol style="list-style-type: none"> 1. Set the factory defaults as shown in Section 4-8 2. Clean all the mode setting buffer 3. Execute Auto Image Adjust <p>Note: Memory Recall should have no effect for Language, Power Lock, User Color Settings or Input Priority</p>
<p>Resolution Notice Actions</p> <ol style="list-style-type: none"> 1. Resolution Notice OSD should show on screen after changing to non-native mode for 30 sec 2. The OSD should disappear after 10 sec or by pushing button [1] or [2] <p>Resolution Notice function should be disabled when push button [2] under Resolution Notice OSD</p>
<p>0-Touch™ Function Actions</p> <ol style="list-style-type: none"> 1. Execute Auto Image Adjust when new mode detected, and save the settings to buffer for further use 2. It should be reset by Memory Recall function (Should not reset by power off, power unplug and others)
<p>OSD Auto Save</p> <p>The OSD shall save new settings when it is turned off by the user or when it times out. There shall not be a separate save</p>

2.7 AUDIO INTERFACE (SPEAKER SPECIFICATION)

Line input connection	3.5 mm stereo jack
Line input signal	1 Vrms
Line input impedance	20kohms
Maximum power output (Electric)	1.5W/CH
Signal to Noise Ratio	72db
Frequency response	300 to 20kHz
Distortion	8%@1kHz
Vibration	There should be no audible vibration with volume at 100%. (Input signal within 1 Vrms)
Screen image	There should be no affect on the screen image stability under any conditions
Connector PC99 requirement Audio in	Lime Green pantone # 577C
Cable type / length	3.5mm stereo cable / 1.8m length
Audio DPMS	Note: There is no guarantee <1 W power consumption in Active Off mode, when the Audio Cable is connected

3. Front Panel Function Control Description

Adjusting the Screen Image

Use the buttons on the front control panel to display and adjust the OSD controls which display on the screen. The OSD controls are explained at the top of the next page and are defined in “Main Menu Controls” on page 10.

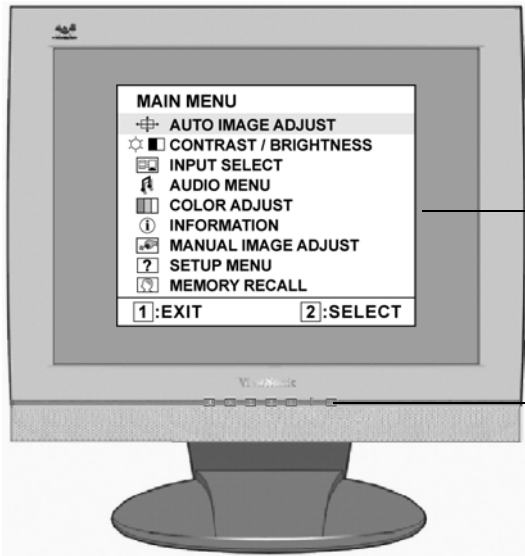

Main Menu
with OSD controls

Front Control Panel
shown below in detail

Displays the Main Menu or exits the control screen and saves adjustments.

Scrolls through menu options and adjusts the displayed control.
Also a shortcut to display the Contrast adjustment control screen.

Displays the control screen for the highlighted control.
Also toggles between two controls on some screens.
Also a shortcut to toggle analog and digital connection.

Audio Mute button turns the sound off

Power light
Green = ON
Orange = Power Saving

Standby Power On/Off

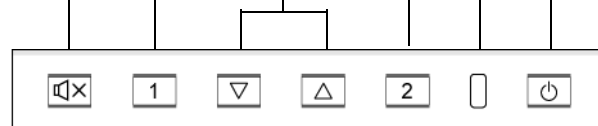

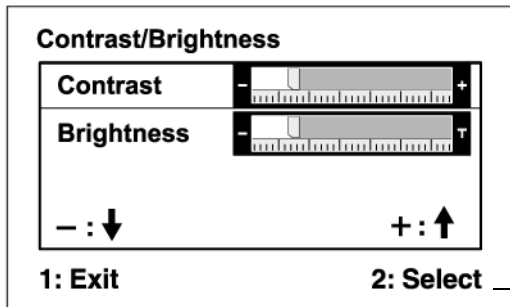
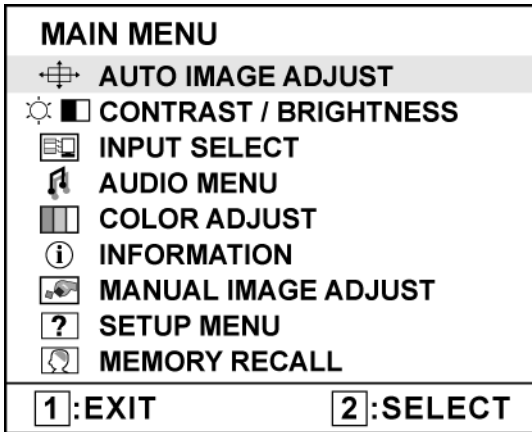







The command line at the bottom of the control screen tells what to do next from this screen. You can toggle between control screens, adjust the selected option, or exit the screen.

_____ (The black border around the edge of the screen should barely touch the illuminated “active area” of the LCD display.)

Main Menu Controls

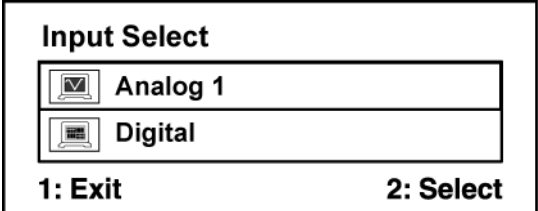
Adjust the menu items shown below by using the up ▲ and down ▼ buttons.

Control	Explanation
	Auto Image Adjust sizes and centers the screen image automatically.
	Contrast adjusts the difference between the image background (black level) and the foreground (white level).
	Brightness adjusts background black level of the screen image.
	Input Select toggles between inputs if you have more than one computer connected to the VA1912w/VA1912wb.
	
	Audio Adjust Volume increases the volume, decreases the volume, and mutes the audio. Mute temporarily silences audio output.
	Color Adjust provides several color adjustment modes, including preset color temperatures and a User Color mode which allows independent adjustment of red (R), green (G), and blue (B). The factory setting for this product is 6500K (6500 Kelvin).

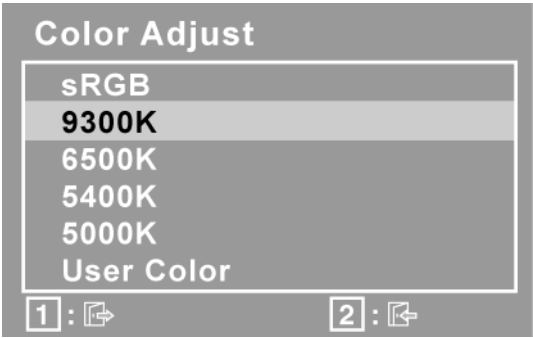

9300K-Adds blue to the screen image for cooler white (used in most office settings with fluorescent lighting).

6500K-Adds red to the screen image for warmer white and richer red.

5400K-Adds green to the screen image for a darker color.

Control	Explanation
---------	-------------



Fine Tune sharpens the focus by aligning text and/or graphics with pixel boundaries.

NOTE: Try Auto Image Adjust first.



Sharpness adjusts the clarity and focus of the screen image.



Setup Menu displays the menu shown below:

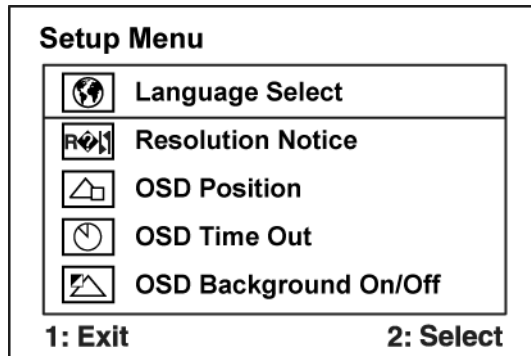

Language Select allows the user to choose the language used in the menus and control screens.



Resolution Notice allows the user to enable or disable this notice.

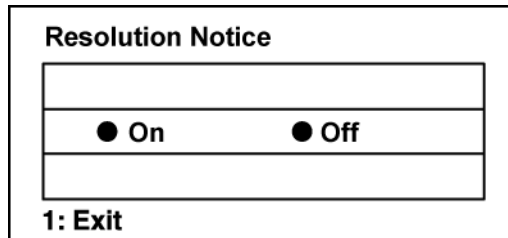

If you enable the Resolution Notice shown above and your computer is set at a resolution other than 1440 x 900, the following screen appears.

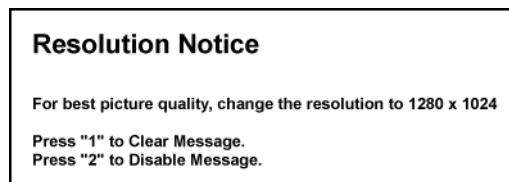

OSD Position allows the user to move the OSD menus and control screens.



OSD Timeout sets the length of time the OSD screen is displayed. For example, with a “30 second” setting, if a control is not pushed within 30 seconds, the display screen disappears.

Control	Explanation
---------	-------------



OSD Background allows the user to turn the OSD background On or Off.



Memory Recall returns the adjustments back to factory settings if the display is operating in a factory Preset Timing Mode listed in the Specifications of this manual.

4. Circuit Description

1. LCD Integrated Power System (LIPS)

The LCD Integrated Power System (LIPS) is a power module combined adaptor and CCFL inverter. It accepts 100~240Vac and supply 12Vdc and 5Vdc to main board and TFT-LCD panel. About CCFL dimming and on/off function is controlled by micro-controller.

2. Scaler

The TSU56AK is total solution graphics processing IC for LCD monitors with panel resolutions up to SXGA. It is configured with a high-speed integrated triple-ADC/PLL, an integrated DVI receiver, a high quality display processing engine, and an integrated output display interface that can support LVDS panel interface format. To further reduce system costs, the TSU56AK also integrates intelligent power management control capability for green-mode requirements and spread-spectrum support for EMI management. The TSU56AK incorporates the world's first coherent oversampled RGB graphics ADC in a monitor controller system. The oversampling ADC samples the input RGB signals at a frequency that is much higher than the signal source pixel rate. This can preserve details in the video signal that ordinarily would be lost due to input signal jitter or bandwidth limitations in non-oversampled systems. The TSU56AK also incorporates a new Dynamic Frame Rate (DFR) generator for the digital output video to the display panel that preserves the advantages of a fixed output clock rate, while eliminating the output end of frame short-line.

Block Diagram

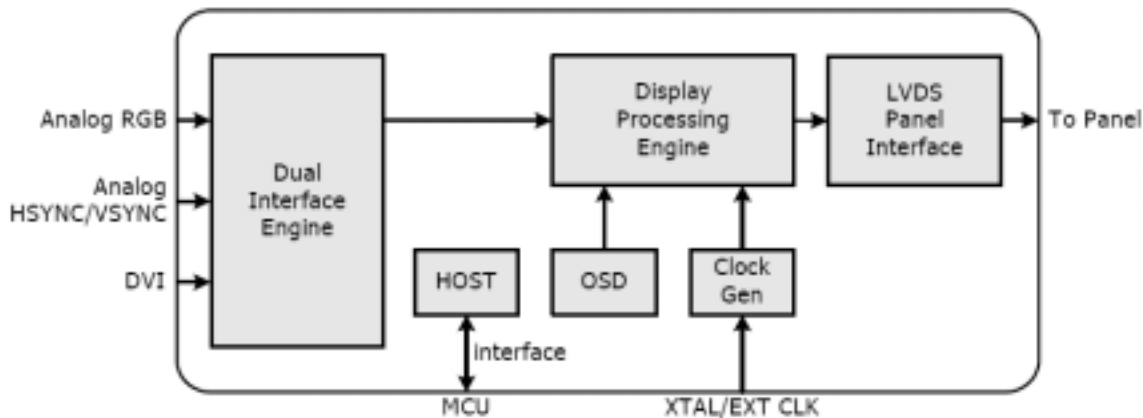

3. Timing Controller

The CM2706B is a timing controller LSI for Office Application. It receives LVDS RGB data and synchronizes signal from external video graphic adapter and then outputs RSDS (Reduced Swing Differential Signal) data and TTL control signals to TFT LCD drivers.

Block Diagram

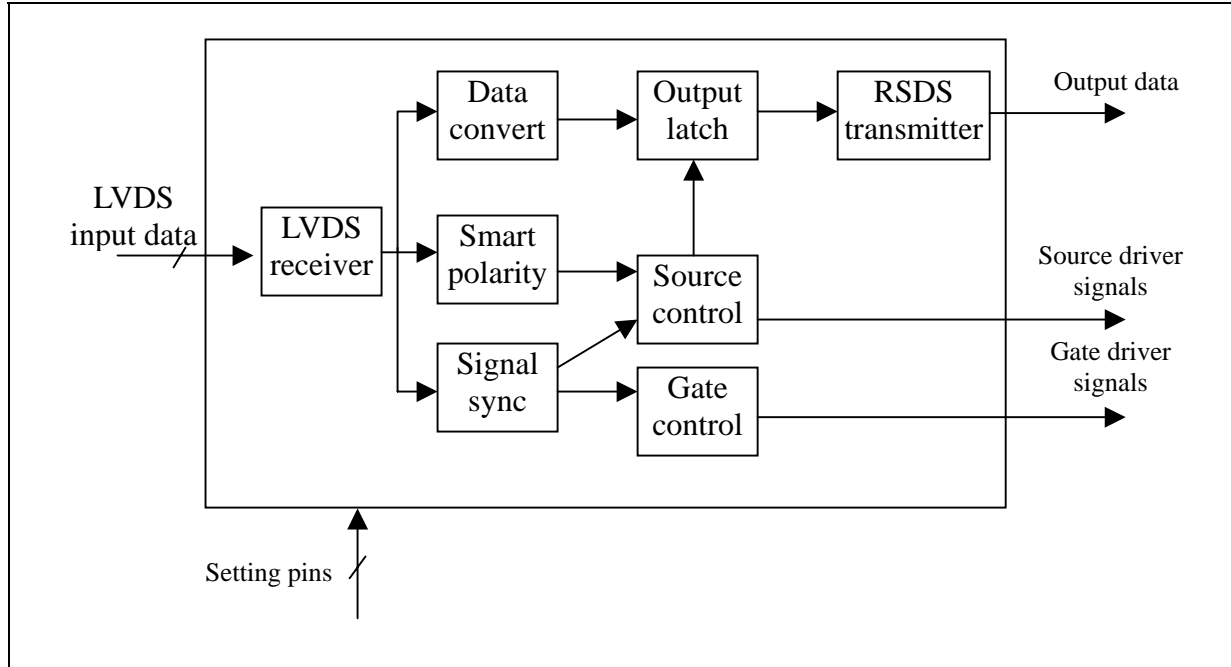

5. Adjusting Procedure

A. Function Test and Alignment Procedure

1. All Modes Reset

You should do “All Model Reset” (Refer to Chap 3. Hot Keys for Function Controls) first. This action will allow you to erase all end-user’s settings and restore the factory defaults.

2. Auto Image Adjust

The Auto Adjust is aimed to offer a best screen quality by built-in ASIC. For optimum screen quality, the user has to adjust each function manually.

A. Turn the computer and LCD monitor on.

B. Press the ‘Auto’ button on monitor keypad to Auto Adjust.

C. The LCD monitor will start the Auto Adjust process automatically and run for 10 consecutive seconds, during which time you will notice the image change.

3. Firmware

Test Patten: Burn in Model (Refer to Chap3. Hot Keys for Function Control)

-Make sure the F/W is the latest version.

4. DCC

Test Patten: EDID program

-Make sure it can pass test program.

5 Window Shut Down

Test Signal: 1280*1024@60Hz

Test Pattern:



Checked Pattern Every One Pixel (50%Green & 50%Blue)

Inspection Item: Flicker, Mura

6 Window BG

Test Signal: 1280*1024@60Hz

Test Pattern:



Window standard pattern

Inspection Item: Line Defect, Function Defect & Mura

7 25 Gray

Test Signal: 1280*1024@60Hz

Test Pattern:



Full Screen 25% White (Gray)

Inspection Item: Particle, Line Defect & Mura

8 50 Gray

Test Signal: 1280*1024@60Hz

Test Pattern:



Full Screen 50% White (Gray)

Inspection Item: Bright Dot, Particle, Line Defect & Mura

9 White Box

Test Signal: 1280*1024@60Hz

Test Pattern:

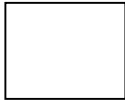

Window standard pattern

Inspection Item: Particle, Line Defect, Power, Image Remain & Mura

10 Black Box

Test Signal: 1280*1024@60Hz

Test Pattern:



Window standard pattern

Inspection Item: Bright Dot, Line Defect & Power

11 RED

Test Signal: 1280*1024@60Hz

Test Pattern:



Full Screen Red

Inspection Item: Bright Dot, Partial & Line Defect

12 Green

Test Signal: 1280*1024@60Hz

Test Pattern:



Full Screen Green

Inspection Item: Bright Dot, Partial & Line Defect

13 Blue

Test Signal: 1280*1024@60Hz

Test Pattern:



Full Screen Green

Inspection Item: Bright Dot, Partial & Line Defect

14 Gray_Scale_0-100_V256

Test Signal: 1280*1024@60Hz

Test Pattern:

Vertical 64 (256) Gray Scale (Right Left , From 0 to 100% White)



Inspection Item: Line Defect & Function Defect

15 Gray_Scale_0-100_H256

Test Signal: 1280*1024@60Hz

Test Pattern:



Horizontal 64(256) Gray Scale (Up Down , From 0 to 100% White)

Inspection Item: Line Defect & Function Defect

16 Block Window

Test Signal: 1280*1024@60Hz

Test Pattern:

Black block at the center



Inspection Item: Cross Talk & Optical Character

17 Black_Tile

Test Signal: 1280*1024@60Hz

Test Pattern:

Black tile under white background



Inspection Item: Function Defect & Image Remain

15. Function Test Display pattern

Item	Pattern	Description	Remark
1	Gray_Scale_0-100_V	Vertical 64 (256) Gray Scale (右 左 , From 0 to 100% White)	Figure 1
2	Gray_Scale_0-100_H	Horizontal 64 (256) Gray Scale (上 下 , From 0 to 100% White)	Figure 2
3	Black	Full Screen Black	Figure 3
4	Red	Full Screen 50% Red	Figure 4
5	Green	Full Screen 50% Green	Figure 5
6	Blue	Full Screen 50% Blue	Figure6
7	White	Full Screen White	Figure7
8	Black_Tile	Black Tile Under White Background	Figure 8

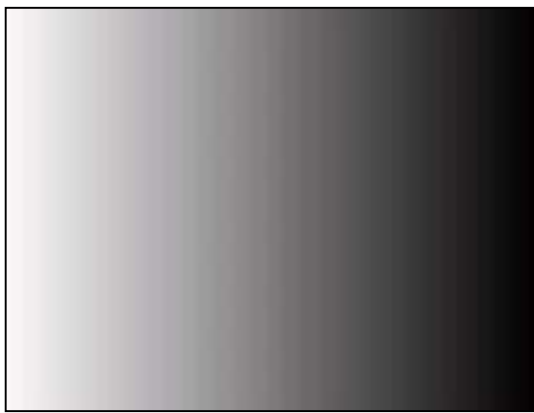

Figure 1



Figure 2

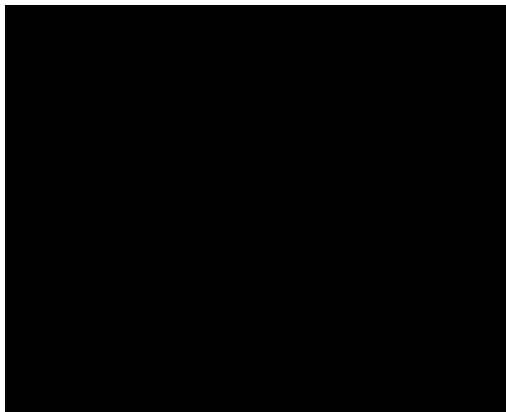

Figure 3

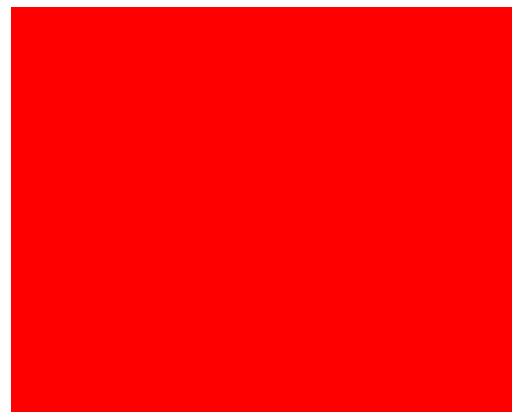

Figure 4

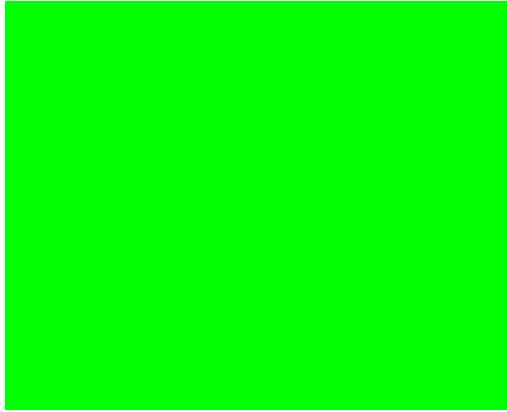

Figure 5

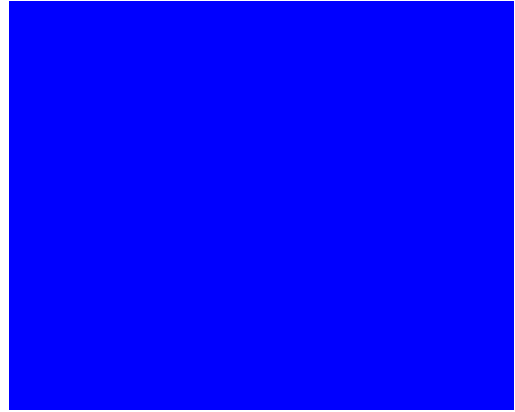

Figure 6



Figure 7

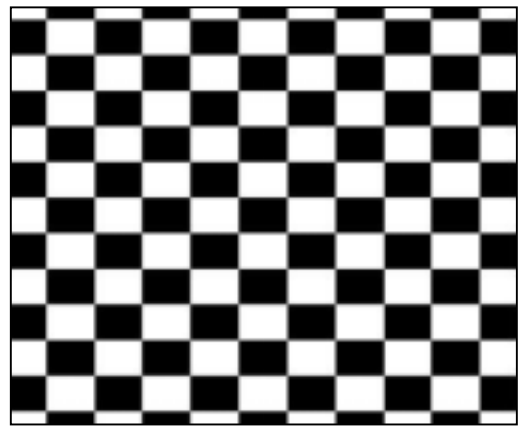

Figure 8

B. BIOS update procedure

BIOS Update User Guide

FOR VIEWSONIC

BIOS Update Flow for Genesis

1.1 Program :

1.1.1. Software

a. Please download the file “ M-Star” from CMO E-Sir system. There are ISP & BIOS two files, kindly see as below.

a) ISPACK.EXE: Main program



Port95nt.exe

b) Ancillary .ISPACK.EXE : Description program



Setup.exe

1.1.2. Hardwar

- D_Sub cable (15Pin)
- Point plug [24Pin]

Point plug



D_Sub cable



OR



Without to affect

1.1.3 Join VGA Cable, PC BASE, see the example picture as below.



1.2 Installation :

A. Please install the programs respectively as below.



B. ISP & BIOS software file to be about to produce the next. (If the file existence already, needn't to set up.



C. repeat.) This system is applied to Win 95/98/NT/2000.

1.3 ISP Execution

1. Settings:



Double Click

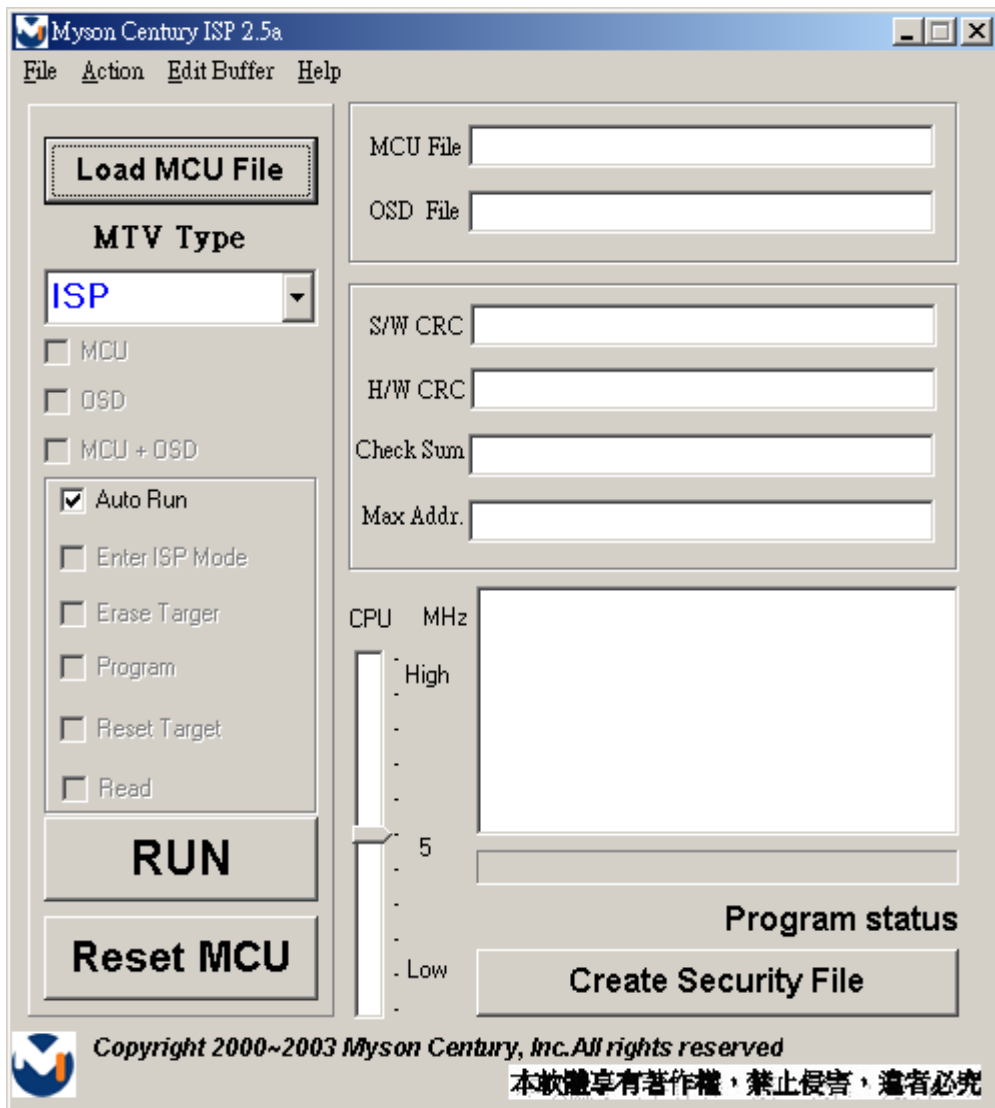
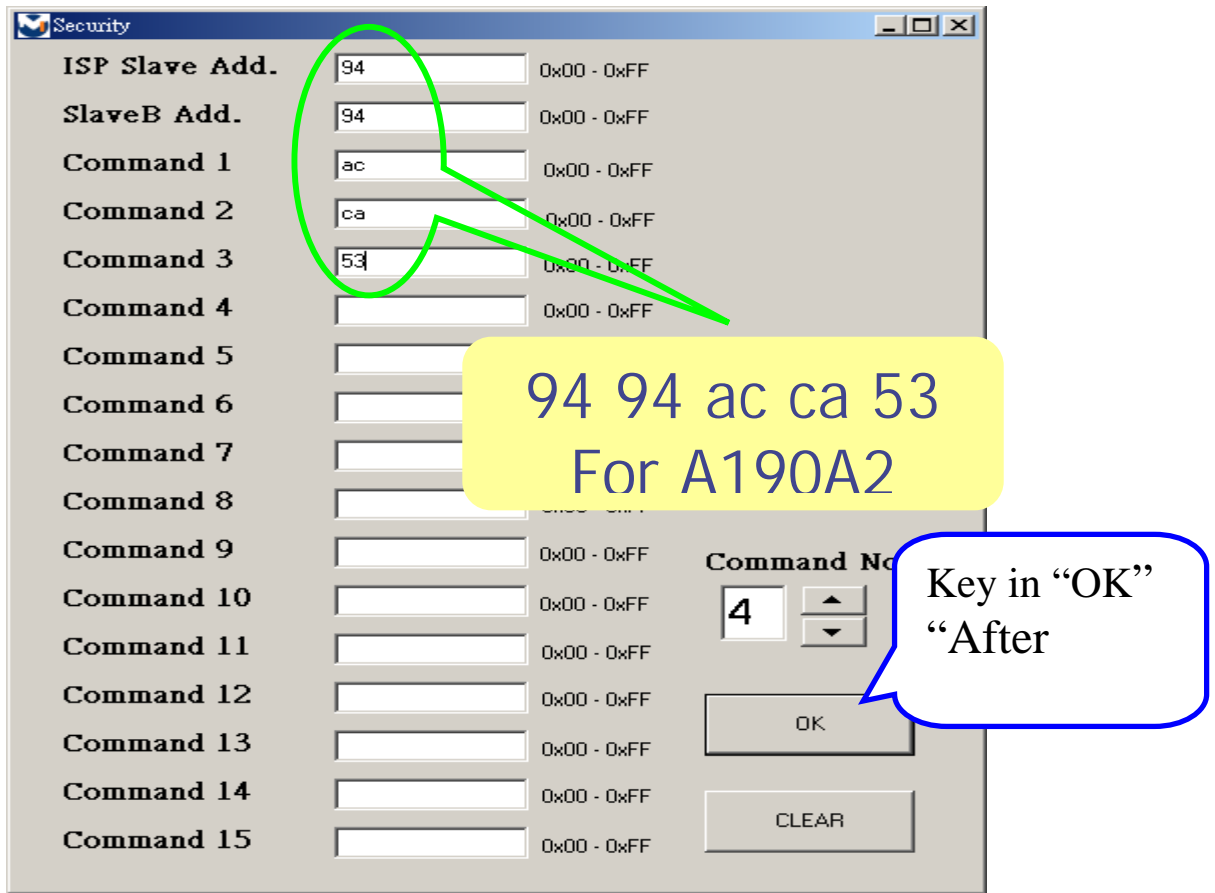
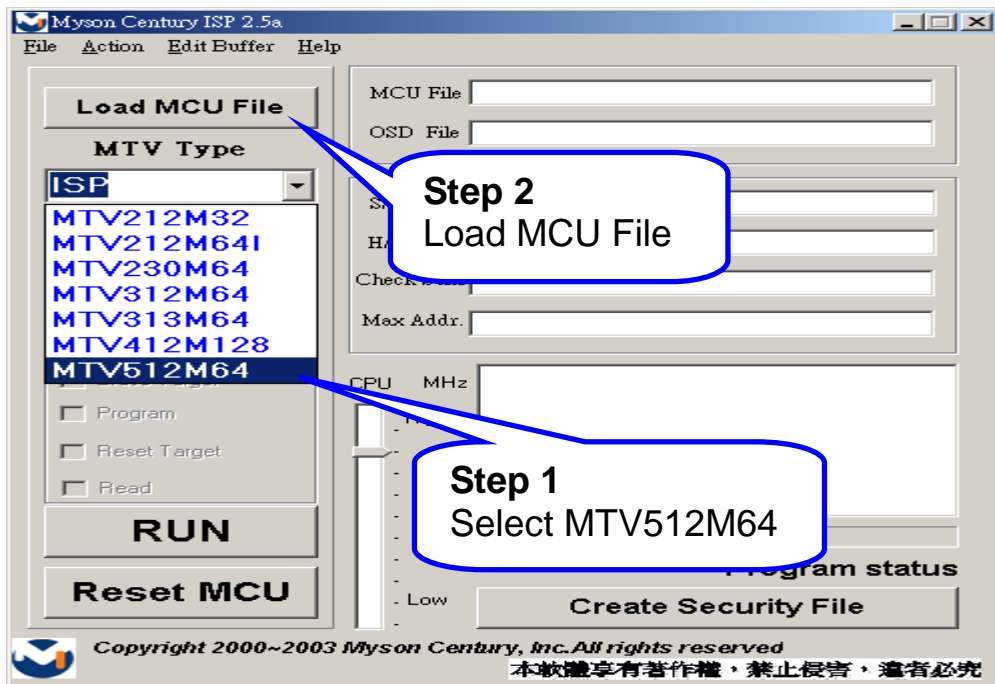

Fig.1: ISP Tool Main Menu

2. When *ISP Tool* executing at the first time, it is required to enter *Security* Data Please press **Creat Security File**, then input related information as Fig.2.



3. Select correct *Micro Controller* as Fig.3.



4. Installation software, Select want download correct file

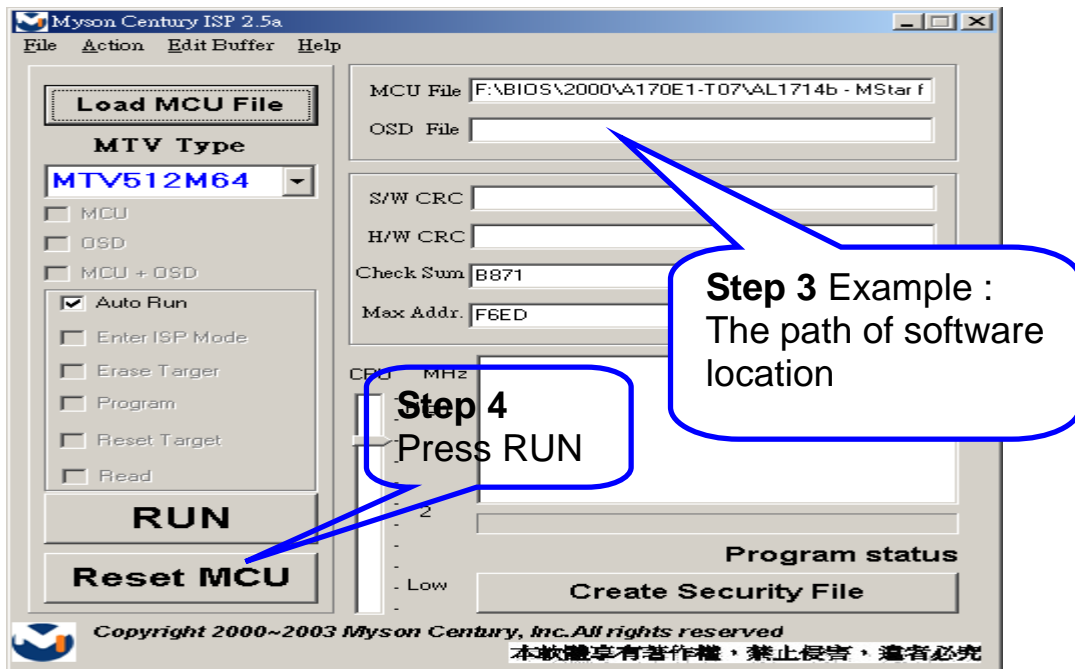
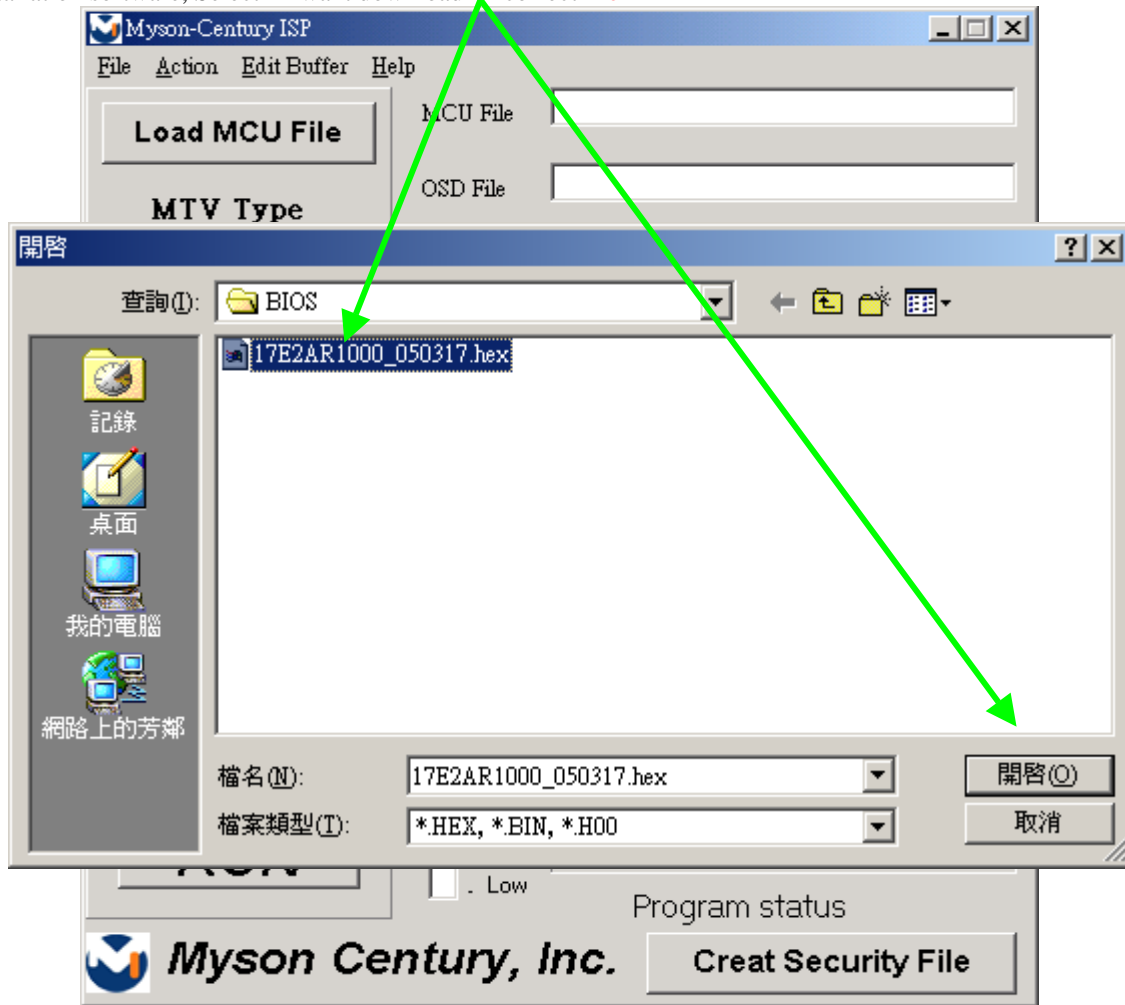

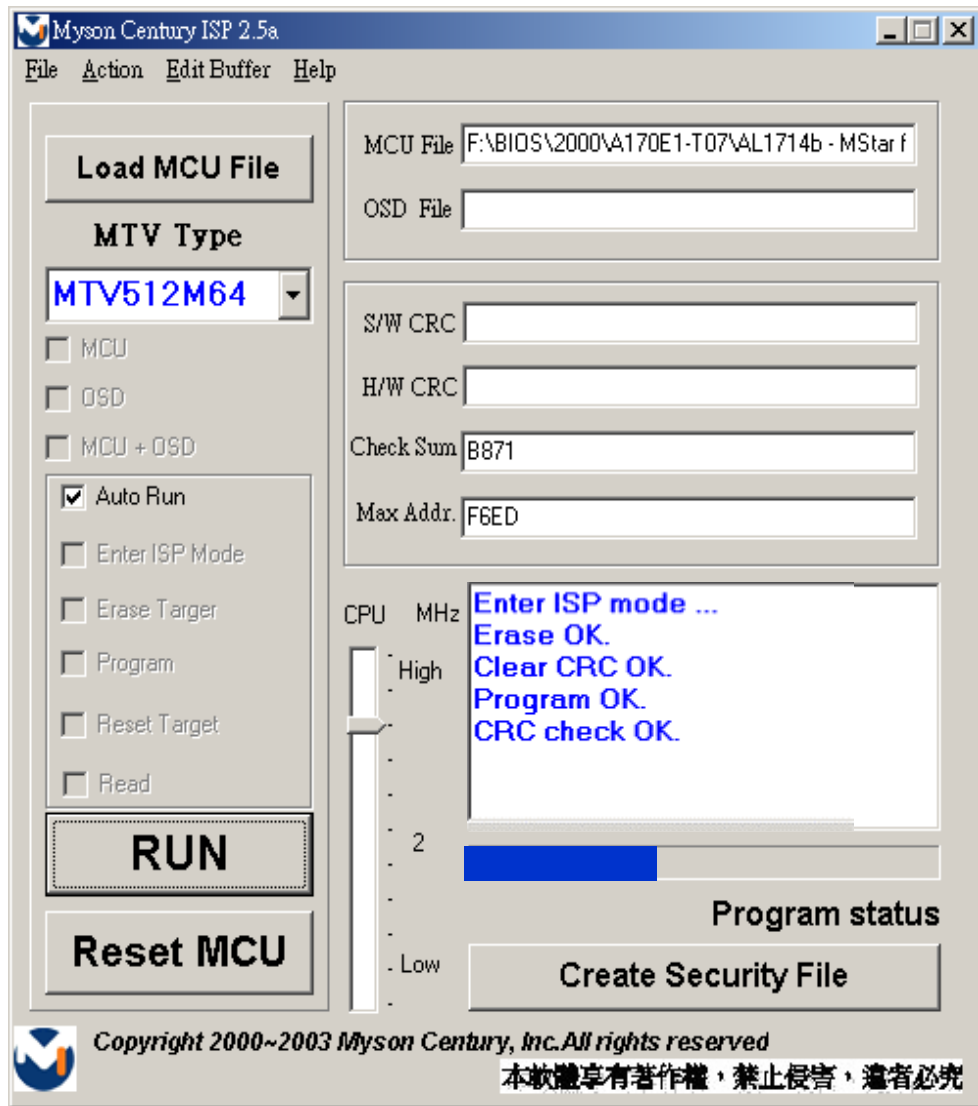

1.4.Verification BIOS Update whether success

1. When everything is done. Please turn off the power and restart it again.
Check Factory Mode and make sure it already be updated.



C. Monitor Assembly and Disassembly

1 Separate Stand Assy

1.1 Remove Stand Cover

Step 1 :
Take out Stand Assy

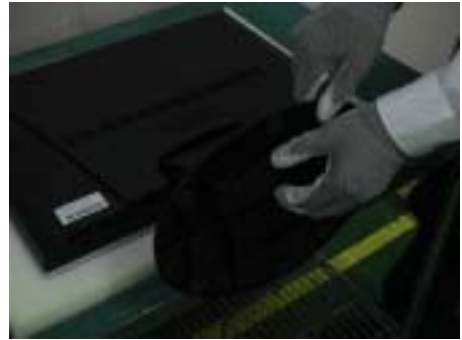

Step 2 :
Remove Cover Hinge



Step 3 :
Loose and Remove 4 screws

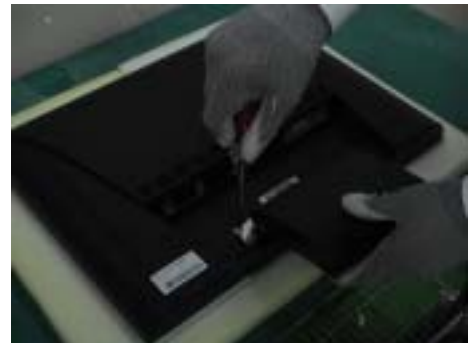

Step 4:
Remove Stand Assy



2 Separate Rear Cover (Rear Case Assy)

Separate Bezel hooks to take Bezel and Rear Cover apart.

Step 1 :

Loose and remove 2 screws.

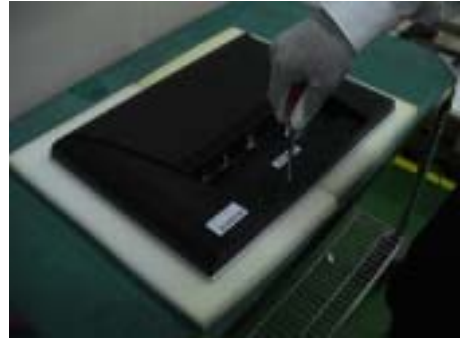

Step 2 :

Separate Bezel hooks to take Bezel and Rear Cover apart.



Step 3 :

Remove Rear Cover.



Step 4 :

Completed.



3 Remove Power Board

3.1 Remove Metal Cover

Step 1 :

Remove 2 pieces of Backlight wires.



Step 2 :

Loose and remove 4 screws



Step 3 :

Loose and remove 2 screws of power socket.



Step 4 :

Loose and remove 2 screws of Digital socket.



Step 5 :
Loose and remove 2 screws of Analog Socket.



Step 6 :
Remove the Metal Cover.

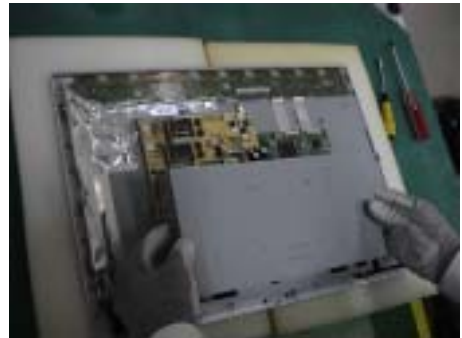

Step 7 :
Completed.



3.2 Remove Power Board

Step 1 :
Remove 2 pieces of Backlight wires.



Step 2 :
Loose and remove 2 screws.



Step 3 :
Remove Power Board.



Step 4 :
Completed.



4 Change New Power Board

Step 1 :
Insert New Power Board.



Step 2 :
Fasten 2 fixed screws
of Power Board.



Step 3 :
Insert 2 pieces of Backlight wires.



Step 4 :
Completed



5. Remove AD PCBA

Step 1 :
Remove 2 FFC from X Board.



Step 2 :
Remove FFC from OSD Board.



Step 3 :
Loose and remove 4 screws.



Step 4 :
Remove AD PCBA.



Step 4 :
Completed.



6. Change New AD PCBA

Step 1 :
Place New AD PCBA.



Step 2 :
Fasten 4 fixed screws of AD PCBA.



Step 3 :
Insert 2 FFC from X Board.



Step 4 :
Insert FFC from OSD Board.



Step 5 :
Completed.



7. Remove OSD Board

Step 1 :
Remove FFC.



Step 2 :
Separate both Audio Cable.



Step 3 :
Take OSD Board apart.



Step 4 :
Completed.



8. Change New OSD Board

Step 1 :
Place New OSD Board.



Step 2 :
Insert Audio cable to connectors of
New OSD Board.



Step 3 :
Insert FFC to OSD Board.



Step 4 :
Completed.



9. Add Cover to AD PCB Heatsink

Step 1 :
Join the cover hooks of X-PCB.



Step 2 :
Fasten 2 fixed screws of Analog
Socket.



Step 3 :
Fasten 2 fixed screws of Digital Socket.



Step 4 :
Fasten 2 fixed screws of Power Socket.



Step 5 :
Fasten 4 fixed screws.



Step 6 :
Insert 2 pieces of Backlight wires.



Step 7 :
Completed.



10. Rear Assy Assembly

Step 1 :
Join the Bazel assy .



Step 2 :
Fasten 4 fixed screws.



Step 3 :
Place Rear Cover.



Step 4 :
Fasten 2 fixed screws.

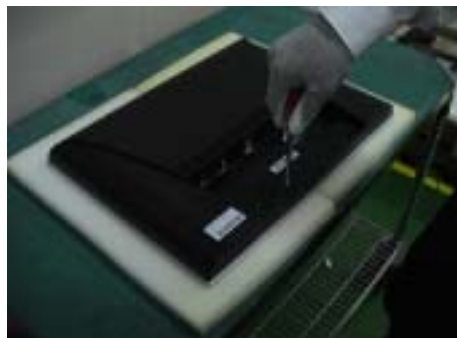

Step 5 :
Completed.



11. Stand Assy Assembly

Step 1 :
Place Stand Assy.



Step 2 :
Fasten 4 screws to fixed Stand Assy.

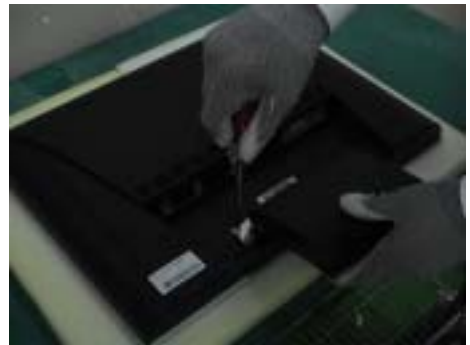

Step 3 :
Insert Cover Hinge.



Step 4 :
Insert Seat Assy.

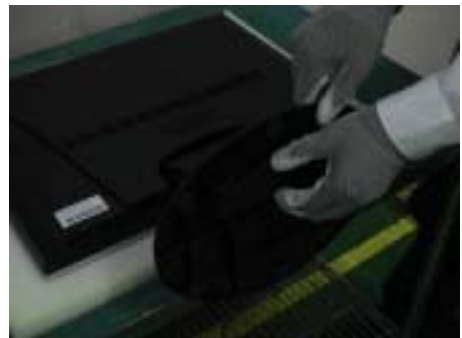

6. Trouble Shooting Analysis

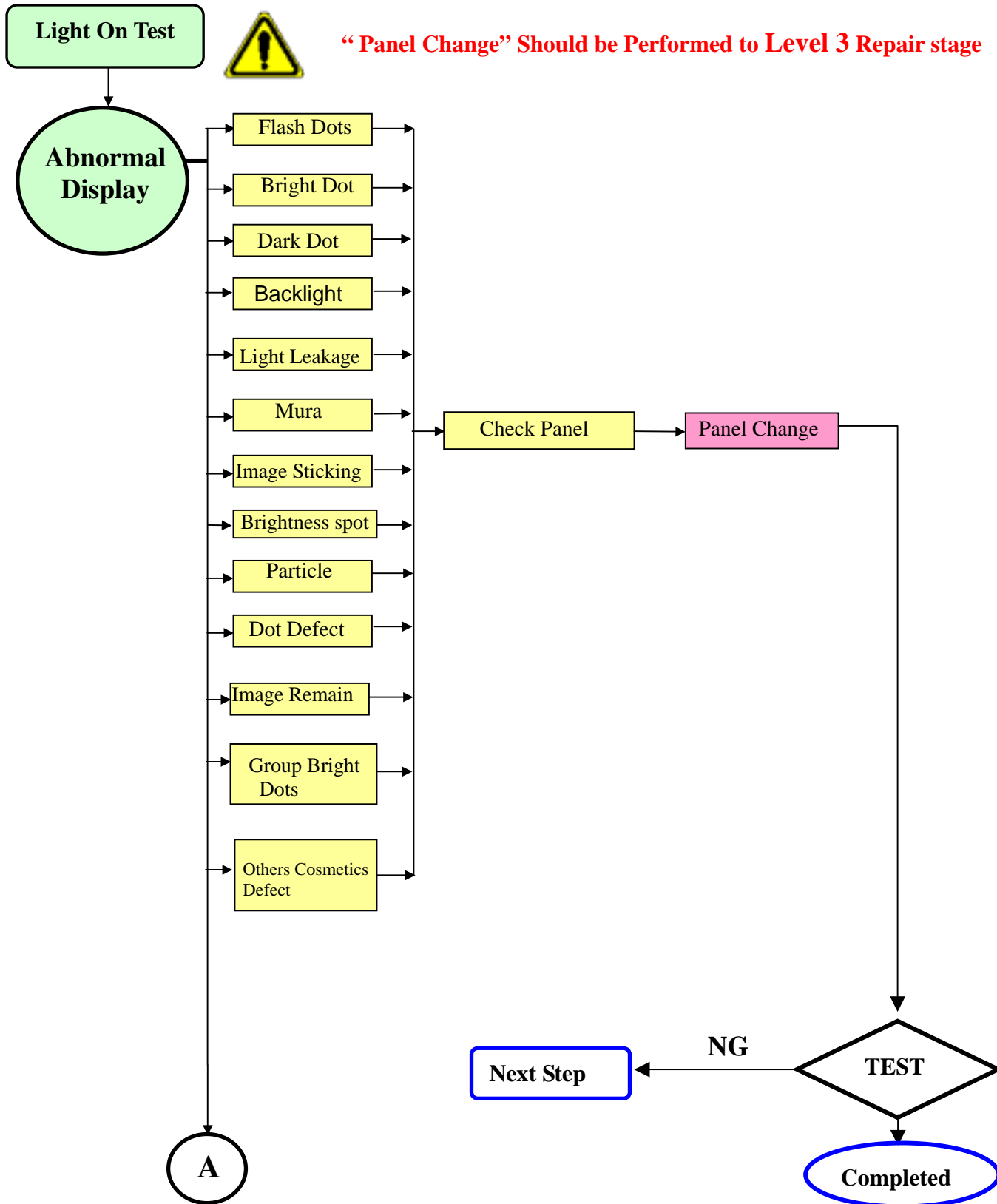



“ Panel Change” Should be Performed to Level 3 Repair stage

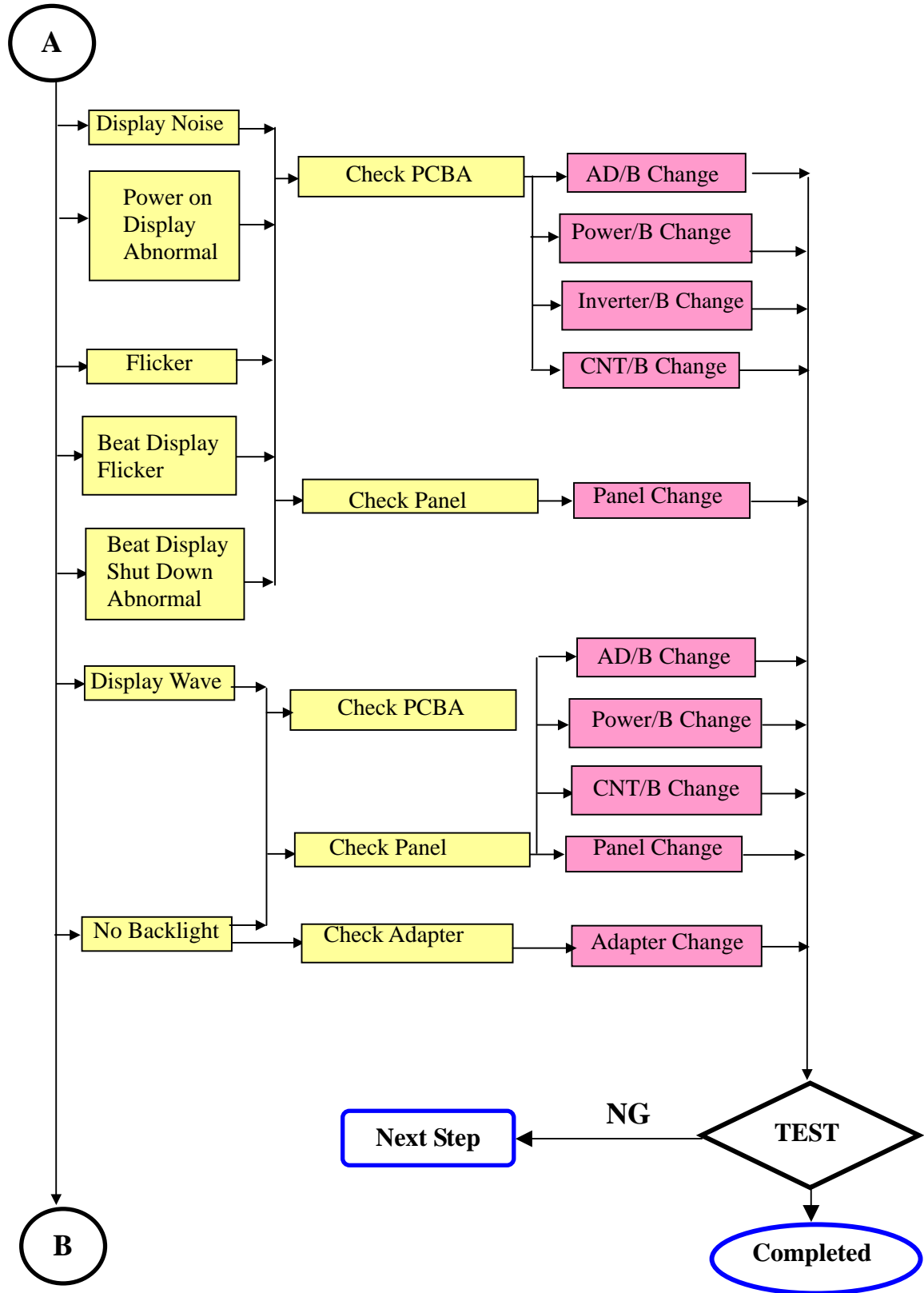



“Panel Change” Should be Performed to Level 3 Repair stage

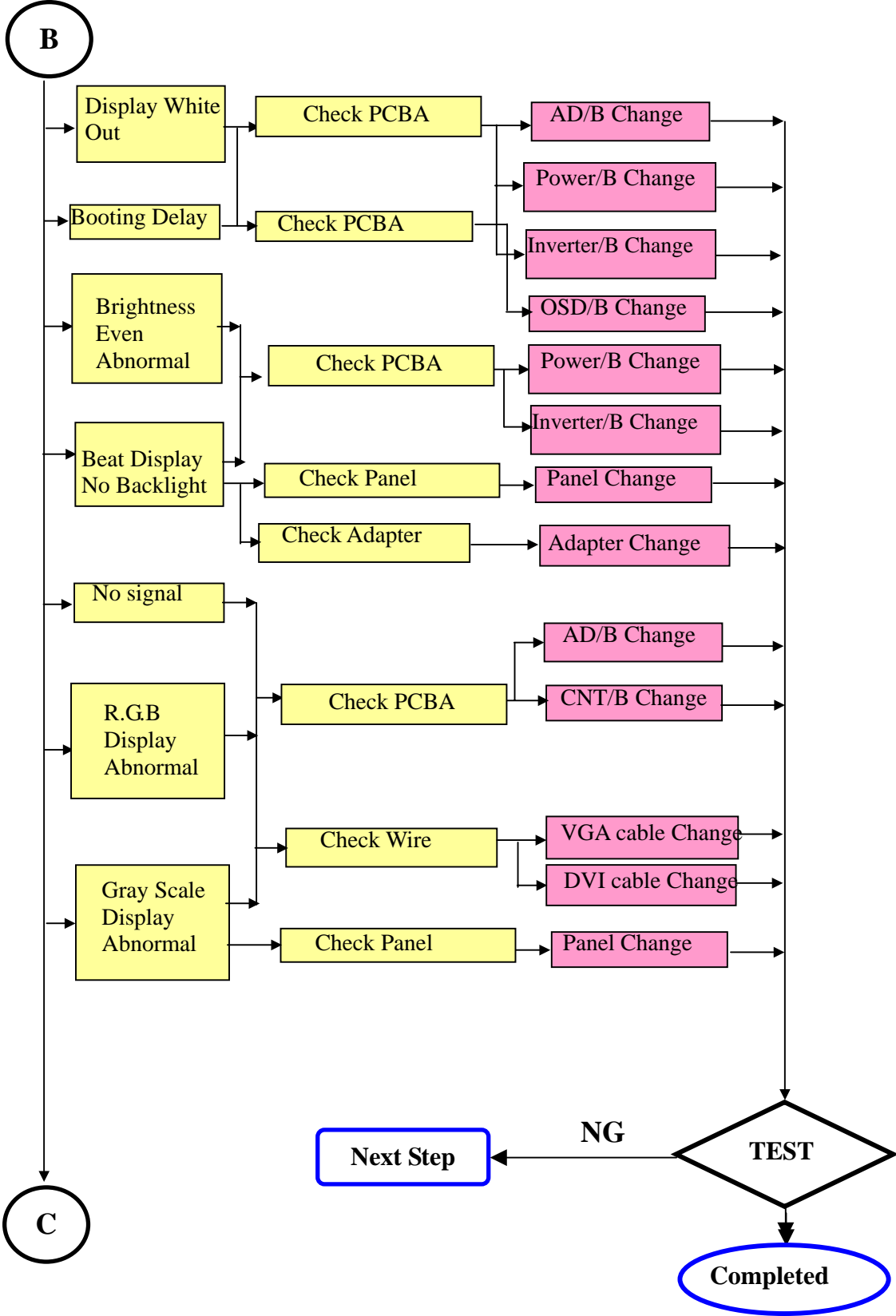



“ Panel Change” Should be Performed to Level 3 Repair stage

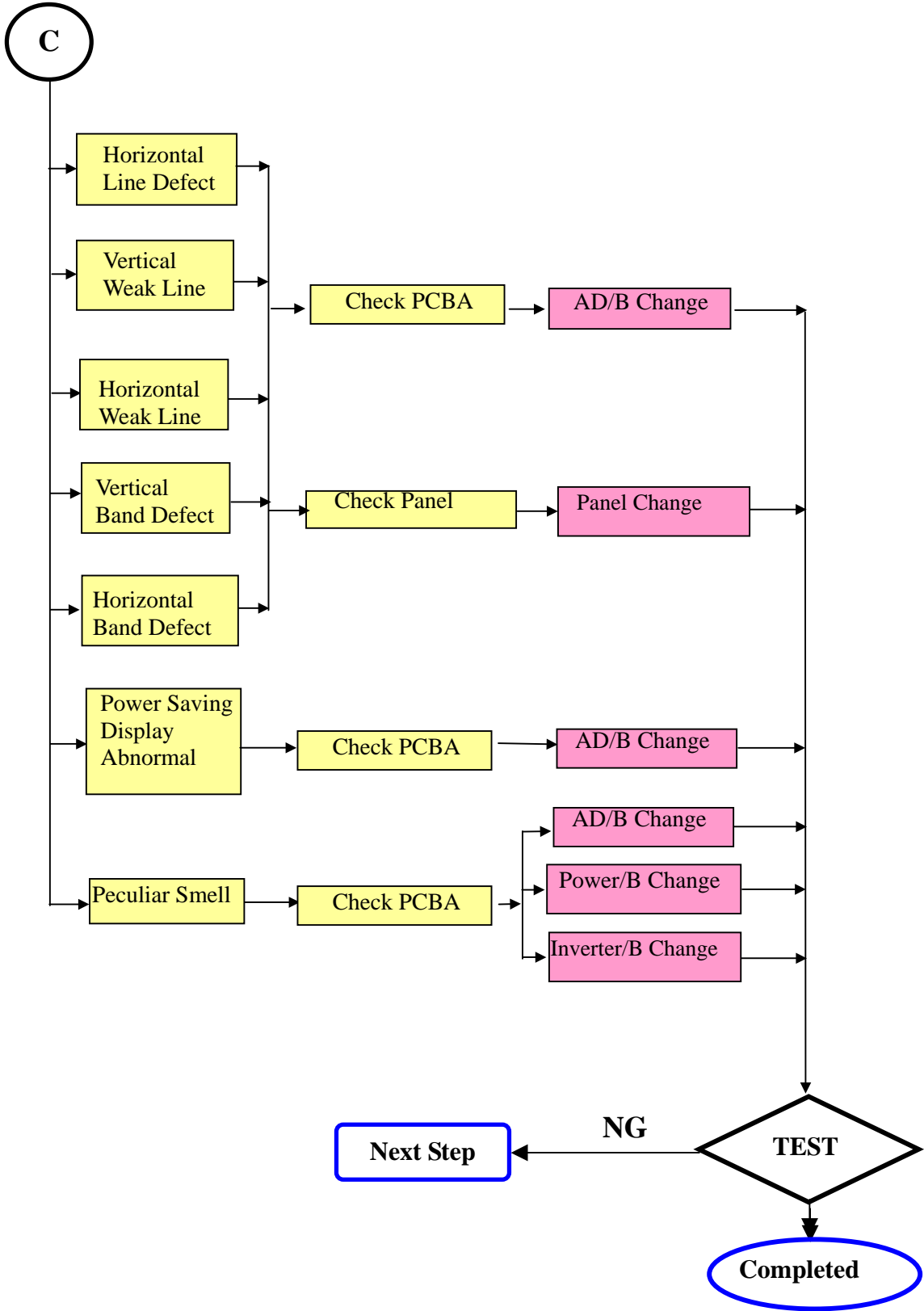



“Panel Change” Should be Performed to Level 3 Repair stage

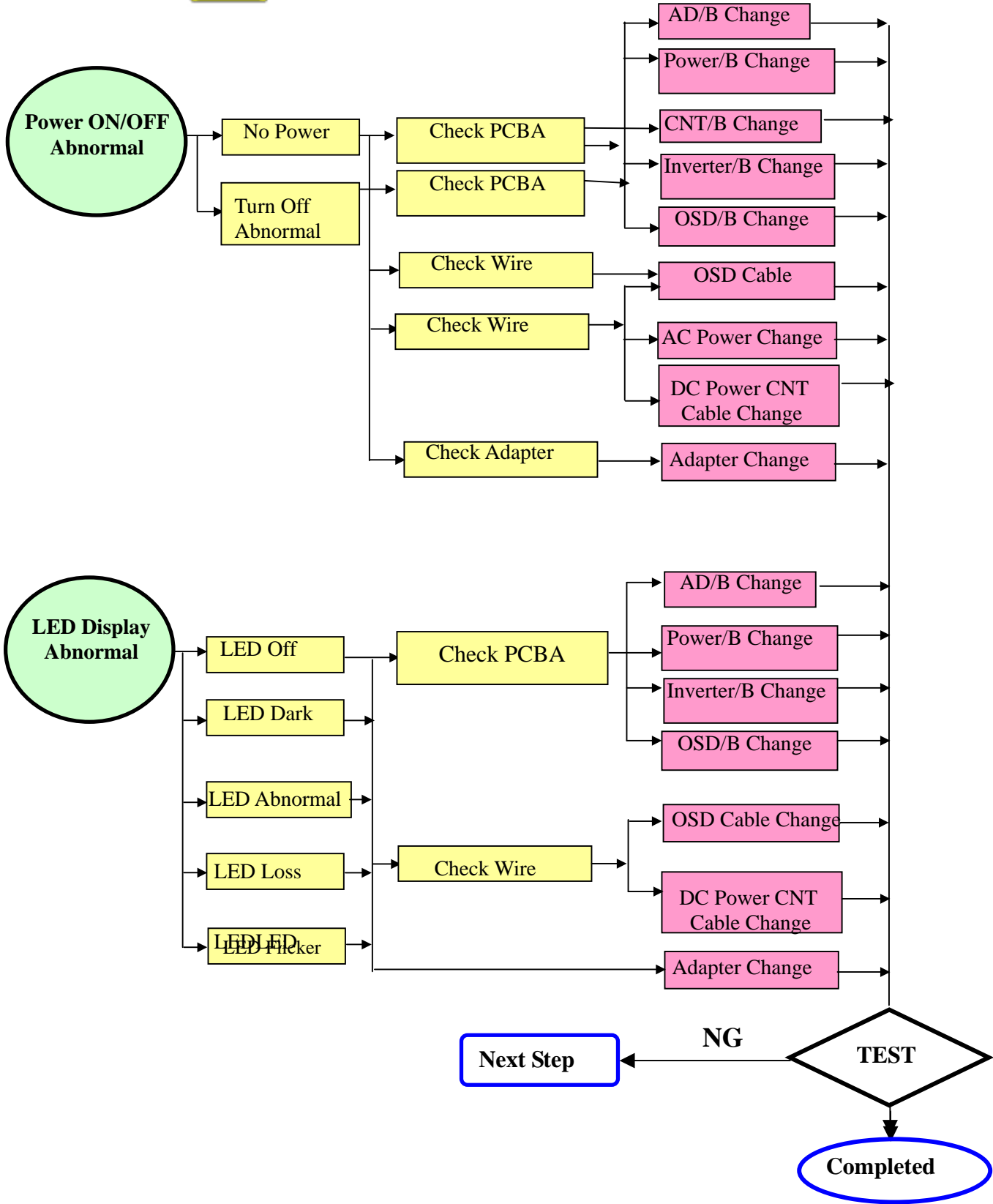



“Panel Change” Should be Performed to Level 3 Repair stage

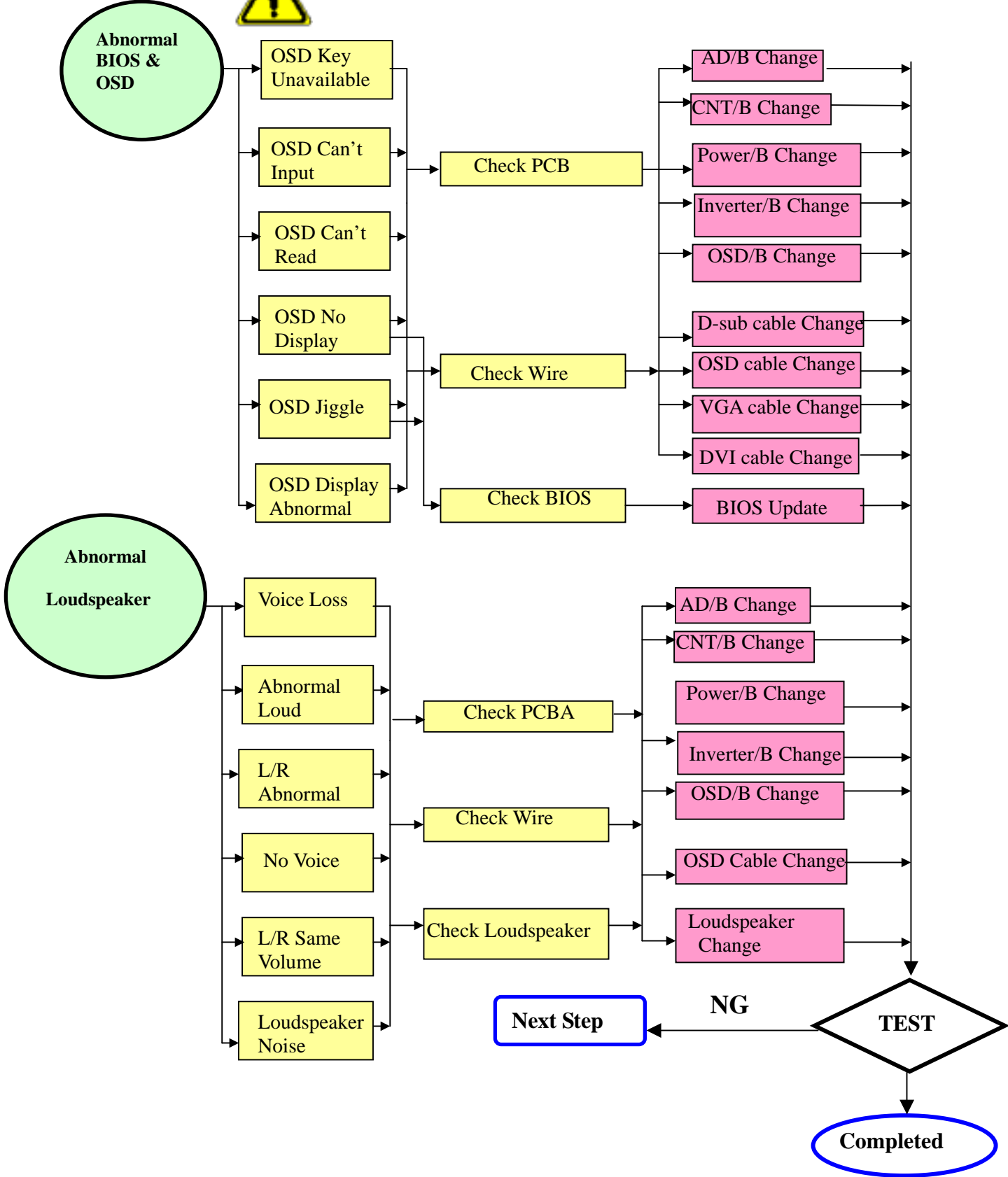



“ Panel Change” Should be Performed to Level 3 Repair stage

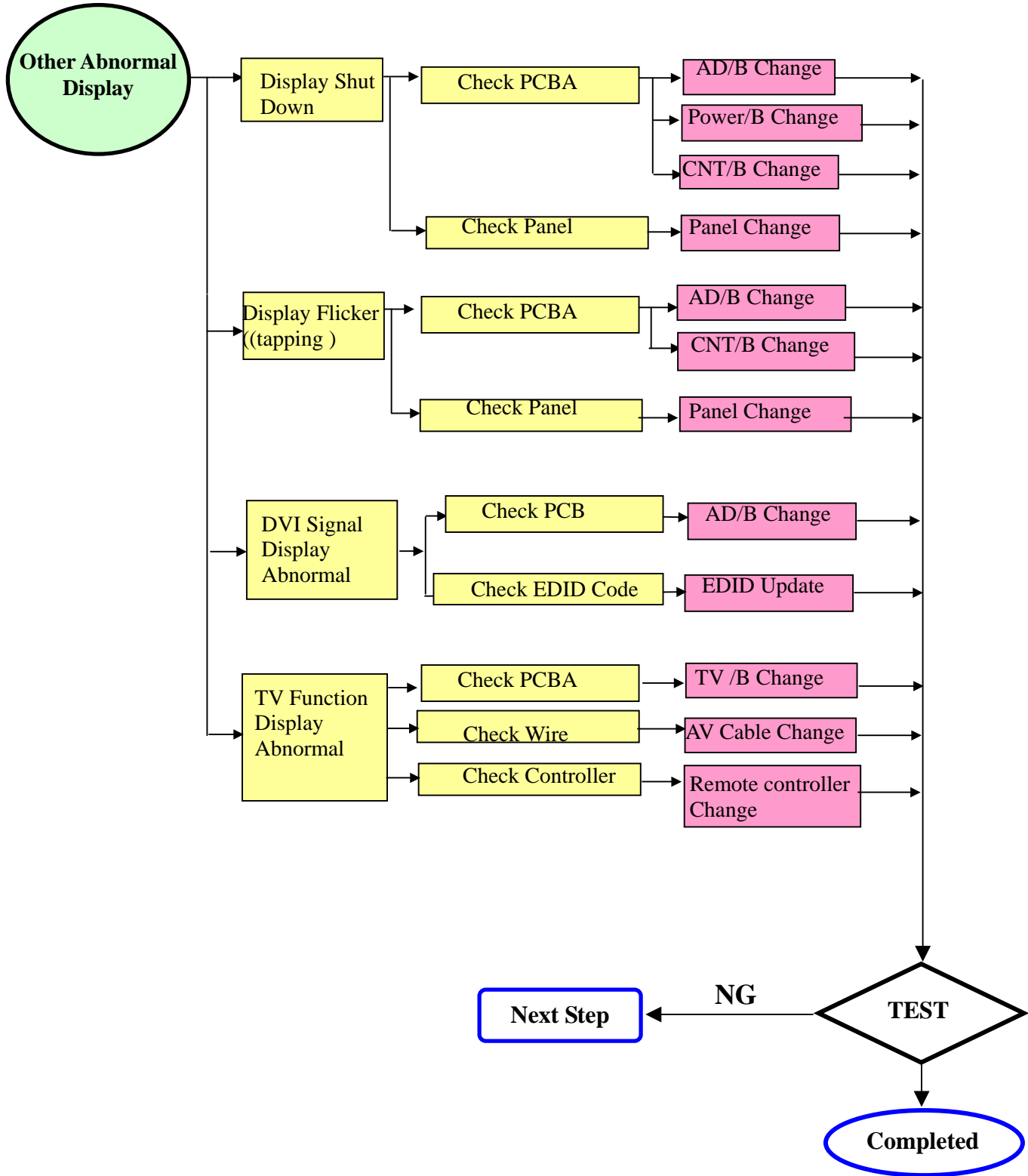

Trouble Shooting Analysis

Check the information in this section to see if the problems can be solved before requesting repair.

Note : The consumers are only allowed to solve the problems described as below. Any unauthorized product modification, or failure to follow instructions supplied with the product will end the warranty immediately.

- **No image**
 - ◆ Make sure power button is ON.
 - ◆ Check whether the LCD monitor and computer power cords are plugged and whether there is a supply of power.
- **No Signal Input**
 - ◆ Check the signal connection between the computer and LCD monitor.
- **“Out of Range”**
 - ◆ Check the computer image output resolution and frequency and compare the value with the preset values (Please refer to [Appendix-Display Mode]).
- **Fuzzy Image**
 - ◆ Adjust Phase.
- **Image too bright**
 - ◆ Adjust brightness and contrast by OSD.
- **Image too dark**
 - ◆ Adjust brightness and contrast by OSD.
- **Irregular image**
 - ◆ Check the signal connection between the computer and LCD monitor.
 - ◆ Perform Auto Adjust.
- **Distorted image**
 - ◆ Reset the LCD monitor
 - ◆ Take off extra accessories (such as signal extension cord).
- **Image is not centered**
 - ◆ Use OSD Image Menu to adjust H_Position and V_Position.
 - ◆ Check image size setting.
 - ◆ Perform Auto Adjust.
- **Size is not appropriate**
 - ◆ Use OSD Image Menu to adjust H_Position and V_Position.
 - ◆ Check image size setting.
 - ◆ Perform Auto Adjust.
- **Uneven color**
 - ◆ Use OSD Color Menu to adjust color setting.
- **Color too dark**
 - ◆ Use OSD Color Menu to adjust color setting.
- **Dark area distorted**
 - ◆ Use OSD Color Menu to adjust color setting.
- **White color is not white**
 - ◆ Use OSD Color Menu to adjust color setting.

7. Recommended Spare Parts List

RECOMMENDED SPARE PARTS LIST (VA1912w-1)

ViewSonic Model Number: VS10866-1W

Rev: 1a

Serial No. Prefix: PXD

Item	Description	ECR/ECN	ViewSonic P/N	Ref. P/N	Location	Universal number#	Q'ty
1	Accessories: Adapter, Lips With Audio, DAC-12M030 A, Ver:0F, 5 V/3 A, 12 V/0.7 A, L TYPE, 5 mA, 2470 V		A-00004273	27-D003247			1
2	Power Code, UL, SVT#18/3C, 75 , LP-30B+LS-13, L=1830+/-50mm, Black, Linetek, 18AWG, No Bag		CB-00000544	32E1818015 (AJ0A2H1A15/25)			1
3	Power Cord, CCC, 300/500V, 0.75mm2, 3C, PC-323+COC-01, L=1830+/-50mm, Black, Linetek, 18AWG, No Bag		A-00000458	32E1818013 (AJ0A2H1C15/25)			1
4	Power Code, CEE, SP-023+IS-14, H05VV-F, 3G, 0.75mm2, CT-12, L=1800+/-50mm, I-SHENG, 18AWG, Black, No Bag		A-00002058	32E1818018 (AJ0A2H1E15/25) (AJ0A2H1K15/25)			1
5	Power Cord, BSI, H05VV-F, 0.75mm2, 3C, LP-60L+LS-60, L=1830+/-50mm, Black, 18AWG, PSB Mark, Linetek, No Bag		A-00002059	32E1818060 (AJ0A2H1K15/25)			1
6	Power Cord, VCTF 3G 0.75mm^2 CNS CT-08, Black, BSMI, 1800 mm, I Sheng		A-00002057	32-D001922 (AJ0A2H1W15/25)			1
7	Board Assembly: PCBA for , A190A2-H, A190A2-H-S1, 106-03, Rev.03		B-00004274	35-D003166			1
8	PCBA for , A190A2-H, A190A2-H-K3-01, 106-01,		B-00004275	35-D004528			1
9	Cabinets: Bezel Assy, A190A2-H05, ABS PA757N, Silver(Pantone877C), Fuking		C-00004281	40-D004255 (AJ0A2H1A.C.E.K.W25)			1
10	Rear Assy, A190A2-H05, ABS PA757N, Black(J91A11B5), Fuking		C-00004282	40-D004257 (AJ0A2H1A.C.E.K.W25)			1
11	Stand Assy, A190A2-H05, ABS PA757N, Black(J91A11B5), Hontech Precision		C-00004283	40-D004252 (AJ0A2H1A.C.E.K.W25)			1
12	Cover Hinge, A190A2-H05, ABS PA757N, Black(J91A11B5), Fuking		C-00004284	40-D004250 (AJ0A2H1A.C.E.K.W25)			1
13	Seat Assy, A190A2-H05, ABS PA757N, Black(J91A11B5), Hontech Precision		C-00004285	40-D004259 (AJ0A2H1A.C.E.K.W25)			1
14	Cables: FFC, FFCX816, 36 Pins, Tenssure, package AL_Foil		CB-00004286	32-D002888			2
15	Accessory Cable, D-Sub, BLACK, Johnson Components & Equipments, A150X2		CB-00004287	32F3018003			1
16	Audio Cable, A150X2, 18AWG, 180cm, Black, JCE		CB-00000547	32F2818004			1
17	FFC, A190A2-H05, 15 Pins, Tenssure, L=108.5		CB-00004288	32-D004533			1
18	Documentation Safety Label for , A190A2-H05, 120 mmx50 mm, Chang Huang, VSC_VA1912W		DC-00004289	77-D004406 (AJ0A2H1A.C.E.K.W15)			1
19	Label, Bar-Code Labe, 55*13mm		DC-00004291	77A1519181			1
20	Carton Label for , A190A2-H05, 76.2 mmx76.2 mm, Chang Huang, VSC_VA1912W		DC-00002073	77-D004411 (AJ0A2H1A.C.E.K.W15)			1
21	MENU for A190A2-H05, Complex, 1C, Yi-Ching Special Printing, VSC_VA1912W+Caution Card		DC-00004293	76-D004408 (AJ0A2H1A15/25)			1
22	Hardware: Screw, M3*P0.5*4, f 5.5*2		HW-00004295	42A9930008			2000
23	SCREW, M4, P=0.7 mm, L=8 mm, Round Head, Phillips Cross Recess, plate Ni, Screw_with_Washer, SHYE CHING SCREW, head D8		HW-00000553	42-D000649			2000
24	Stand-Off 4 # -40*11.8		HW-00004042	42A9940007			2000
25	Screw, M3*P1.27*12, f 5.5*2		M-00000559	42A9990005			2000
26	Screw, M4*P0.7*15, f 7*2.6, +SW+W		HW-00000556	42A9930013			2000
27	Screw, M3*P0.5*6		HW-00000590	42A9930014			2000
28	Miscellaneous: Tape, Security Tape, OPP, L900xW50x0.045mm, VSC		HW-00000555	7345511002			1
29	Packing Material: PE Foam Bag, Protector, 570*600*0.13, A190E1-H01, white		M-00000560	7841919921			1
30	Cushion, A190A2-T05, EPS, WHITE, 450 mmx160 mmx145 mm, Sing Home, PS FOAM (TOP)		P-00000595	78-D004392			1
31	Cushion, A190A2-T05, EPS, WHITE, 450 mmx160 mmx145 mm, Sing Home, PS FOAM (BOTTOM)		P-00004296	78-D004388			1
32	Carton, A190A2-H05, 538 mmx158 mmx470 mm, Chen Ti Paper, VSC_VA1912W		P-00004297	78-D004412 (AJ0A2H1A.C.E.K.W15)			1

RECOMMENDED SPARE PARTS LIST (VA1912wb-1)

ViewSonic Model Number: VS10866-1W

Rev: 1a

Serial No. Prefix: PW6

Item	Description	ECR/ECN	ViewSonic P/N	Ref. P/N	Location	Universal number#	Q'ty
1	Accessories: Adapter, Lips With Audio, DAC-12M030 A, Ver:0F, 5 V/3 A, 12 V/0.7 A, L TYPE, 5 mA, 2470 V		A-00004273	27-D003247			1
2	Power Code, UL, SVT#18/3C, 75 , LP-30B+LS-13, L=1830+/-50mm, Black, Linetek, 18AWG, No Bag		CB-00000544	32E1818015 (AJ0A2H1A15/25)			1
3	Power Cord, CCC, 300/500V, 0.75mm2, 3C, PC-323+COC-01, L=1830+/-50mm, Black, Linetek, 18AWG, No Bag		A-00000458	32E1818013 (AJ0A2H1C15/25)			1
4	Power Code, CEE, SP-023+IS-14, H05VV-F, 3G, 0.75mm2, CT-12, L=1800+/-50mm, I-SHENG, 18AWG, Black, No Bag		A-00002058	32E1818018 (AJ0A2H1E15/25) (AJ0A2H1K15/25)			1
5	Power Cord, BSI, H05VV-F, 0.75mm2, 3C, LP-60L+LS-60, L=1830+/-50mm, Black, 18AWG, PSB Mark, Linetek, No Bag		A-00002059	32E1818060 (AJ0A2H1K15/25)			1
6	Power Cord, VCTF 3G 0.75mm^2 CNS CT-08, Black, BSML, 1800 mm, I Sheng		A-00002057	32-D001922 (AJ0A2H1W15/25)			1
7	Board Assembly: PCBA for , A190A2-H, A190A2-H-S1, 106-03, Rev.03		B-00004274	35-D003166			1
8	PCBA for , A190A2-H, A190A2-H-K3-01, 106-01, Rev.01		B-00004275	35-D004528			1
9	Cabinets: Bezel Assy, A190A2-H05, ABS PA757N, Midnight(H93828B5), Fuking		C-00004276	40-D004254 (AJ0A2H1A.C.E.K.W15)	40-D004254		1
10	Rear Assy, A190A2-H05, ABS PA757N, Midnight(H93828B5), Fuking		C-00004277	40-D004253 (AJ0A2H1A.C.E.K.W15)	40-D004253		1
11	Stand Assy, A190A2-H05, ABS PA757N, Midnight(H93828B5), Hontech Precision		C-00004278	40-D004251 (AJ0A2H1A.C.E.K.W15)	40-D004251		1
12	Cover Hinge, A190A2-H05, ABS PA757N, Midnight Gray(H93828B5), Fuking		C-00004279	40-D004258 (AJ0A2H1A.C.E.K.W15)			1
13	Seat Assy, A190A2-H05, ABS PA757N, Midnight(H93828B5), Hontech Precision		C-00004280	40-D004256 (AJ0A2H1A.C.E.K.W15)	40-D004258		1
14	Cables: FFC, FFCX816, 36 Pins, Tenssure, package AL_Foil		CB-00004286	32-D002888			2
15	Accessory Cable, D-Sub, BLACK, Johnson Components & Equipments, A150X2		CB-00004287	32F3018003			1
16	Audio Cable, A150X2, 18AWG, 180cm, Black, JCE		CB-00000547	32F2818004			1
17	FFC, A190A2-H05, 15 Pins, Tenssure,		CB-00004288	32-D004533			1
18	Documentation Safety Label for , A190E3-H0F, 120 mmx50 mm, Chang Huang, VSC_VA912-3		DC-00004290	77-D004413 (AJ0A2H1A.C.E.K.W25)	77-D004406		1
19	Label, Bar-Code Labe, 55*13mm		DC-00004291	7741519181			1
20	Carton Label for , A190A2-H05, 76.2 mmx76.2 mm, Chang Huang,		DC-00004292	77-D004409 (AJ0A2H1A.C.E.K.W25)	77-D004411		1
21	MENU for VSC_VA912-3+Caution Card, Paper, 1C, Yi-Ching Special Printing, A190E3-H0F		DC-00004294	76-D004438 (AJ0A2H1C.E.K.W15/25)	76-D004408		1
22	Hardware: Screw, M3*P0.5*4, f 5.5*2		HW-00004295	42A9930008			2000
23	SCREW, M4, P=0.7 mm, L=8 mm, Round Head, Phillips Cross Recess, plate Ni, Screw_with_Washer, SHYE CHING SCREW, head D8		HW-00000553	42-D000649			2000
24	Stand-Off 4 #-40*11.8		HW-00004042	42A9940007			2000
25	Screw, M3*P1.27*12, f 5.5*2		M-00000559	42A9990005			2000
26	Screw, M4*P0.7*15, f 7*2.6, +SW+W		HW-00000556	42A9930013			2000
27	Screw, M3*P0.5*6		HW-00000590	42A9930014			2000
28	Miscellaneous: Tape, Security Tape, OPP, L900xW50x0.045mm, VSC		HW-00000555	7345511002			1
29	Packing Material: PE Foam Bag, Protector, 570*600*0.13, A190E1-H01, white		M-00000560	7841919921			1
30	Cushion, A190A2-T05, EPS, WHITE, 450 mmx160 mmx145 mm, Sing Home, PS FOAM (TOP)		P-00000595	78-D004392			1
31	Cushion, A190A2-T05, EPS, WHITE, 450 mmx160 mmx145 mm, Sing Home, PS FOAM (BOTTOM)		P-00004296	78-D004388			1
32	Carton, A190A2-H05, 538 mmx158 mmx470 mm, Chen Ti Paper, VSC_VA1912Wb		P-00004298	78-D004405 (AJ0A2H1A.C.E.K.W25)	78-D004412		1

BOM LIST (VA1912w-1 & VA1912wb-1)

ViewSonic Model Number: VS10866-1W

Rev: 1a

Serial No. Prefix: PXD / PW6

Item	ViewSonic P/N	Ref. P/N	Description	Location	Universal number#	Q'ty
1	#N/A	MJ0A10AK01	19" Wide Semi Product,A190A2,1440X900,TN			1
2	#N/A	L3J009XXXX	19" Wide PS TN Asahi 0.7mm glass Cr BM 8ms Fast LC (Panel base)	common		1
3	#N/A	74-D000461	Polarizer,CF,Degree 135,415.84 mmx262.15 mmx0.215 mm, LPT-HL56T-12AGA1SU,M190A1,Optimax	common	74-D002213/3612	1
4	#N/A	74-D000462	Polarizer,TFT,Degree 135,414 mmx259.7 mmx0.215 mm, LPT-HL56T-12SU,M190A1,Optimax	common	74-D002212/3613	1
5	#N/A	36X8636401	Driver IC,Scan,HX8636APD400(TSMC),300Channel,HIMAX,RoHS	common		3
6	#N/A	36-D002378	Driver IC,COF,Data,M190A1-L01,HX8018-A050CBAK,Reel,6 bit,432Channel ,HIMAX,RoHS	common		10
7	#N/A	73-C000047	ACF,COG,AC-8405Z-23 1.5mmX100M,100000 mmx1.5 mm, Hitachi Chemical,COG-ACF	common	7344191016	0.0017
8	#N/A	7344191017	ACF,AC-4251FY-16,100M/RL	common		0.0044
9	#N/A	73-D002676	ACF,PCB,AC-9825R-35,100000 mmx1.5 mm,Hitachi Chemical,PCB-ACF	common	7344191004/011	0.0044
10	#N/A	7349951002	Silicone,TORAY/-9187L,white,330g	common		0.4
11	#N/A	35-D003085	PCBA/USI/ USI /Centron Electronics ,ODM,RoHS	common		1
12	#N/A	PJ0AFH0Q00	Olympic,19" Wide,Function BOM,D-sub+DVI+Audio,Morning Star,TN			1
13	#N/A	44-D003584	Backlight Unit,A190A2,Forhouse	common		1
14	#N/A	41-D000643	Metal Frame Front,M190A1-L01,SECC 0.6t,Wai-Gin,18.95"	common		1
15	M-00000559	42A9940007	Stand-Off 4 #-40*11.8	common		4
16	CB-00004286	32-D002888	FFC,FFCX816,36 Pins,Tennsure,package AL_Foil	common		2
17	#N/A	41-D002955	Cover AD Assy,A190A2,secc,JIIN MING Industry	common		1
18	HW-00000553	42A9930008	Screw,M3*P0.5*4,f 5.5*2,Steel	common		16
19	HW-00004042	42-D000649	SCREW,M4,P=0.7 mm,L=8 mm,Round Head,Phillips Cross Recess,plate color Zn, Screw_with_Washer,Shye Ching,head D8	common		1
20	A-00004273	27-D003247	Lips With Audio,DAC-12M030 A,Ver:0F,5 V/3 A,12 V/0.7 A,L TYPE,5 mA,2470 V ,Delta Dong Guan/Delta Jiang Su,RoHS	common		1
21	#N/A	73-D002886	Conductive Tape,PET+Adhesive,409 mmx58.55 mmx0.05 mm,Mylar_Cover_PcbaX_a190a2	common		1
22	B-00004274	35-D003166	PCBA for ,A190A2-H,A190A2-H-S1,106-03,Rev.03,ITC/USI,ODM,RoHS	common		1
23	#N/A	PJ0EAAS000(A15.A25) PJ0EACS000(C15.C25) PJ0EAET000(E15.E25) PJ0EAKU000(K15.K25) PJ0EAW5000(W15.W25)	Olympic,19",Accessory BOM,D-sub+Audio,USA 3 pin,Black,Power built-in;RoHS Olympic,19",Accessory BOM,D-sub+Audio,China 3 pin,Black,Power built-in;RoHS Olympic,19",Accessory BOM,D-sub+Audio,European / Korea 2 pin,Black ,Power built-in;RoHS Olympic,19",Accessory BOM,D-sub+Audio,None,Black,Two power cords of UK & EU for VSC,Power built-in;RoHS Olympic,19",Accessory BOM,D-sub+Audio,Taiwan 3 pin,Black,Power built-in;RoHS			1
24	CB-00000547	32F3018003	Accessory Cable,D-Sub,BLACK,Johnson Components & Equipments,A150X2	common		1
25	CB-00000544	32F2818004	Audio Cable,A150X2,18AWG,180cm,Black,JCE	common		1
26	A-00000458	32E1818015	Power Code,UL,SVT#18/3C,75C,LP-30B+LS-13,L=1830+/-50mm,Black,Linetek,18AWG ,No Bag	A15.25	32E1818019	1
27	A-00002058	32E1818013	Power Cord,CCC,300/500V,0.75mm2,3C,PC-323+COC-01,L=1830+/-50mm, Black,Linetek,18AWG,No Bag	C15.25	32E1818021	1
28	A-00002059	32E1818018	Power Code,CEE,SP-023+IS-14,H05VV-F,3G,0.75mm2,CT-12,L=1800+/-50mm, I-SHENG,18AWG,Black,No Bag	E.K15.25	32E1818016	1
29	A-00002057	32E1818060	Power Cord,BSI,H05VV-F,0.75mm2,3C,LP-60L+LS-60,L=1830+/-50mm, Black,18AWG,PSB Mark,Linetek,No Bag	K15.25	32E1818020	1
30	CB-00004287	32-D001922	Power Cord,VCTF 3G 0.75mm^2 CNS CT-08,Black,BSMI,1800 mm,I Sheng	W15.25		1

Item	ViewSonic P/N	Ref. P/N	Description	Location	Universal number#	Q'ty
31	#N/A	PJ0AI15200(A15) PJ0AI25200(A25) PJ0AI15203(C15) PJ0AI25203(C25) PJ0AI15201(E15) PJ0AI25201(E25) PJ0AI15202(K15) PJ0AI25202(K25) PJ0AI15204(W15) PJ0AI25204(W25)	Olympic,A190A2,ID BOM,D-sub+DVI+Audio,USA,Black,VSC, Olympic,A190A2,ID BOM,D-sub+DVI+Audio,USA,Silver Black,VSC, Olympic,A190A2,ID BOM,D-sub+DVI+Audio,China,Black,VSC, Olympic,A190A2,ID BOM,D-sub+DVI+Audio,China,Silver Black,VSC, Olympic,A190A2,ID BOM,D- sub+DVI+Audio,European,Black,VSC, Olympic,A190A2,ID BOM,D-sub+DVI+Audio,European,Silver Black,VSC, Olympic,A190A2,ID BOM,D-sub+DVI+Audio,UK,Black,VSC, Olympic,A190A2,ID BOM,D-sub+DVI+Audio,UK,Silver Black,VSC, Olympic,A190A2,ID BOM,D-sub+DVI+Audio,TWN,Black,VSC,			1
32	C-00004276	40-D004254	Bezel Assy,A190A2-H05,ABS PA757N,Midnight(H93828B5),Fuking	A.C.E.K.W15		1
33	C-00004281	40-D004255	Bezel Assy,A190A2-H05,ABS PA757N,Silver(Pantone877C),Fuking	A.C.E.K.W25		1
34	C-00004277	40-D004253	Rear Assy,A190A2-H05,ABS PA757N,Midnight(H93828B5),Fuking	A.C.E.K.W15		1
35	C-00004282	40-D004257	Rear Assy,A190A2-H05,ABS PA757N,Black(J91A11B5),Fuking	A.C.E.K.W25		1
36	C-00004278	40-D004251	Stand Assy,A190A2-H05,ABS PA757N,Midnight(H93828B5),Hontech Precision	A.C.E.K.W15		1
37	C-00004283	40-D004252	Stand Assy,A190A2-H05,ABS PA757N,Black(J91A11B5),Hontech Precision	A.C.E.K.W25		1
38	C-00004279	40-D004258	Cover Hinge,A190A2-H05,ABS PA757N,Midnight Gray(H93828B5),Fuking	A.C.E.K.W15		1
39	C-00004284	40-D004250	Cover Hinge,A190A2-H05,ABS PA757N,Black(J91A11B5),Fuking	A.C.E.K.W25		1
40	C-00004280	40-D004256	Seat Assy,A190A2-H05,ABS PA757N,Midnight(H93828B5),Hontech Precision	A.C.E.K.W15		
41	C-00004285	40-D004259	Seat Assy,A190A2-H05,ABS PA757N,Black(J91A11B5),Hontech Precision	A.C.E.K.W25		
42	B-00004275	35-D004528	PCBA for ,A190A2-H,A190A2-H-K3-01,106- 01_Rev.01,USI/ITC,ODM,RoHS	common		1
43	CB-00004288	32-D004533	FFC,A190A2-H05,15 Pins,Tennsure,L=108.5	common	32-D004534	1
44	HW-00000590	42A9930013	Screw,M4*P0.7*15,f 7*2.6,Steel,+SW+W	common		4
45	HW-00000555	42A9930014	Screw,M3*P0.5*6,Steel	common		4
46	HW-00000556	42A9990005	Screw,M3*P1.27*12,f 5.5*2,Steel	common		2
47	#N/A	10-D004477	Software (BIOS),A190A2,Ver.NR19A2LS2000,ViewSonic,Checksum(xxxx),L VDS,All in one	common		
48	#N/A	10-D004475	Software (EDID_D- SUB),A190A2,Ver.NRVSC711CA00,ViewSonic,Checksum(xx),VA 1912w,Analog port	common		
49	#N/A	10-D004474	Software (EDID_DVI),A190A2,Ver.NRVSC711CD00,ViewSonic, Checksum(xx),VA1912w,DVI port	common		
50	#N/A	7345511002	Tape,Security Tape,OPP,L900xW50x0.045mm,VSC	common		0.058
51	DC-00004289	77-D004406	Safety Label for ,A190A2-H05,120 mmx50 mm,Chang Huang,VSC_VA1912W	A.C.E.K.W15		1
52	DC-00004290	77-D004413	Safety Label for ,A190A2-H05,120 mmx50 mm,Chang Huang,VSC_VA1912Wb	A.C.E.K.W25		1
53	#N/A	77-D004407	SN Label for ,A190A2-H05,50 mmx25 mm,Chang Huang,VSC_VA1912W	A.E.K.W15		1
54	#N/A	77-D004415	SN Label for ,A190A2-H05,50 mmx25 mm,Chang Huang,VSC_VA1912Wb	A.E.K.W25		1
55	#N/A	77-D004404	SN Label for ,A190A2-H05,50 mmx25 mm,Chang Huang,VSC_VA1912W_for China	C15		1
56	#N/A	77-D004417	SN Label for ,A190A2-H05,50 mmx25 mm,Chang Huang,VSC_VA1912Wb_for China	C25		1
57	#N/A	77-D000114	Customer Label,A170E1-H0G,180 mm,100 mm	C15.25		1
58	#N/A	77-D000118	Customer Label,A170E1-H0G,130 mm,80 mm	C15.25		1
59	#N/A	77-D001323	Customer Label for ,A170E1-H0G,15 mmx15 mm,Chang Huang,QC Pass Label_VSC_for China	C15.25		1
60	#N/A	7741513161	Label,Pallet Barcode Label,75*40,A150X1-T02	common		0.021
61	#N/A	7741519181	Label,Bar-Code Labe,55*13mm	common		1
62	DC-00004291	77-D004411	Carton Label for ,A190A2-H05,76.2 mmx76.2 mm,Chang Huang,VSC_VA1912W	A.C.E.K.W15		1
63	DC-00004292	77-D004409	Carton Label for ,A190A2-H05,76.2 mmx76.2 mm,Chang Huang,VSC_VA1912Wb	A.C.E.K.W25		1
64	P-00004297	78-D004412	Carton,A190A2-H05,538 mmx158 mmx470 mm,Chen Ti Paper,VSC_VA1912W	A.C.E.K.W15		1

Item	ViewSonic P/N	Ref. P/N	Description	Location	Universal number#	Q'ty
65	P-00004298	78-D004405	Carton,A190A2-H05,538 mmx158 mmx470 mm,Chen Ti Paper,VSC_VA1912Wb	A.C.E.K.W25		1
66	HW-00004295	78-D004392	Cushion,A190A2-T05,EPS,WHITE,450 mmx160 mmx145 mm,Sing Home,PS FOAM (TOP)	common		1
67	P-00004296	78-D004388	Cushion,A190A2-T05,EPS,WHITE,450 mmx160 mmx145 mm,Sing Home,PS FOAM (BOTTOM)	common		1
68	#N/A	7841919921	PE Foam Bag,Protector,570*600*0.13,A190E1-H01,white	common		1
69	#N/A	7841595111	Corner Protector,50 mmx50 mmx1850 mm	common		0.083
70	#N/A	7841995111	Separator, 1130x955x11,A190E1-H01	common		0.021
71	#N/A	78-D000801	Pallet,N150X6,Wooden,Fumigation,1200 mmx1000 mmx135 mm,Hua Sun Paper	common		0.021
72	DC-00004293	76-D004408	MENU for A190A2-H05,Complex,1C,Yi-Ching Special Printing,VSC_VA1912W+Caution Card	A15.25		1
73	DC-00004294	76-D004438	MENU for A190A2-H05,Complex,1C,Yi-Ching Special Printing,VSC_VA1912W CD_Rom	C.E15, K.W15/25		1
74	#N/A	76-D004437	MENU for A190A2-H05,Complex,1C,Yi-Ching Special Printing,VSC_VA1912Wb CD_Rom	C.E25		1
75	#N/A	79-D004425	Shipping Package Information for ,A190A2-H05,ViewSonic	common		1
76	#N/A	78-D000275	Warranty Card,A170E1-H0G,143 mmx210 mm,VSC_VA712	C15.25		1

8. Exploded Diagram and Exploded Parts List

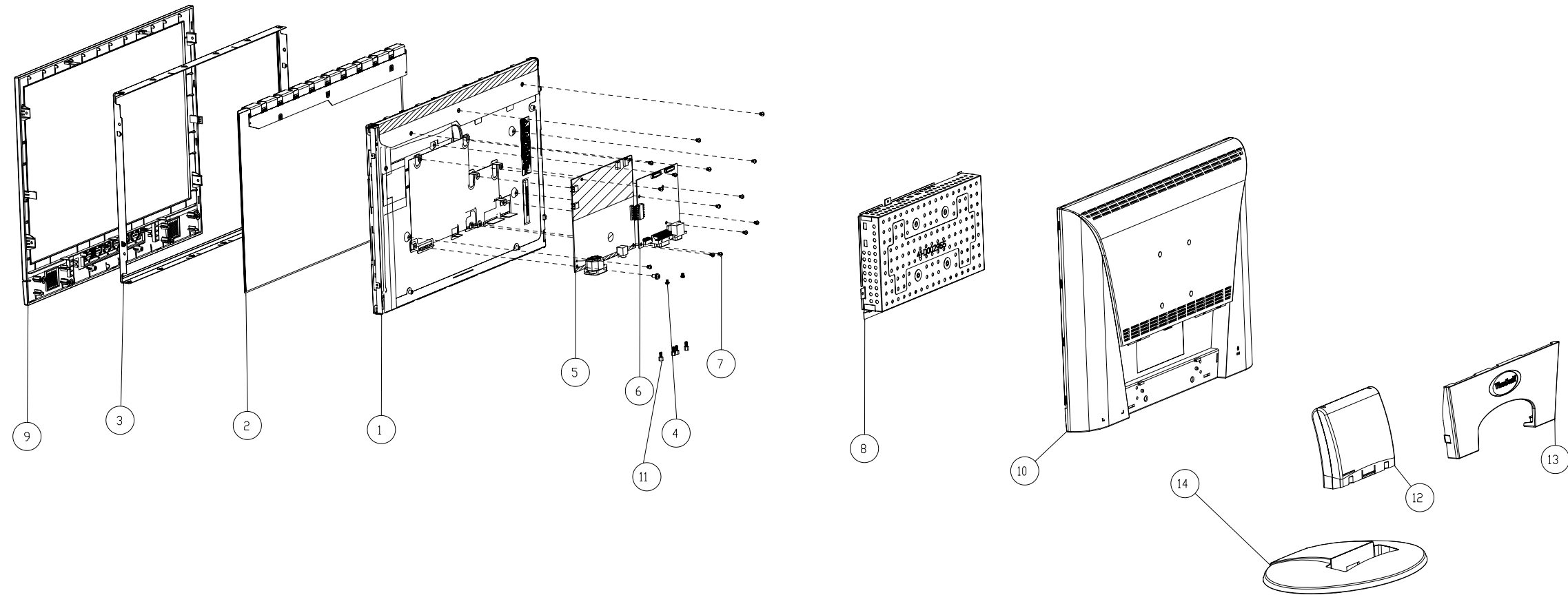

ViewSonic Corporation	
Model	
Title	
Date	Rev:

EXPLODED PARTS LIST (VA1912w-1 & VA1912wb-1)

ViewSonic Model Number: VS10866-1W

Rev: 1a

Serial No. Prefix: PXD / PW6

Item	ViewSonic P/N	Ref. P/N	Description
1	#N/A	44-D003584	Backlight Unit,A190A2,Forhouse
2	#N/A	L3J009XXXX	19" Wide PS TN Asahi 0.7mm glass Cr BM 8ms Fast LC (Panel base)
3	#N/A	41-D000643	Metal Frame Front,M190A1-L01,SECC 0.6t,Wai-Gin,18.95"
4	HW-00000555	42A9930014	Screw,M3*P0.5*6,f 5.3*2.3,Steel
5	A-00004273	27-D003247	Lips With Audio,DAC-12M030 A,Ver:0F,5 V/3 A,12 V/0.7 A,L TYPE,5 mA,2470 V, Delta Dong Guan/Delta Jiang Su,RoHS
6	B-00004274	35-D003166	PCBA for ,A190A2-H,A190A2-H-S1,106-03,Rev.03,ITC/USI,ODM,RoHS
7	HW-00000555	42A9930014	Screw,M3*P0.5*6,f 5.3*2.3,Steel
8	#N/A	41-D002955	Cover AD Assy,A190A2,secc,JIIN MING Industry
9	C-00004276	40-D004254	Bezel Assy,A190A2-H05,ABS PA757N,Midnight(H93828B5),Fuking
	C-00004281	40-D004255	Bezel Assy,A190A2-H05,ABS PA757N,Silver(Pantone877C),Fuking
10	C-00004277	40-D004253	Rear Assy,A190A2-H05,ABS PA757N,Midnight(H93828B5),Fuking
	C-00004282	40-D004257	Rear Assy,A190A2-H05,ABS PA757N,Black(J91A11B5),Fuking
11	HW-00000557	42A9930017	Screw,f 3*P1.27*8,f 5.5*2,Steel
12	C-00004278	40-D004251	Stand Assy,A190A2-H05,ABS PA757N,Midnight(H93828B5),Hontech
	C-00004283	40-D004252	Stand Assy,A190A2-H05,ABS PA757N,Black(J91A11B5),Hontech Precision
13	C-00004279	40-D004258	Cover Hinge,A190A2-H05,ABS PA757N,Midnight Gray(H93828B5),Fuking
	C-00004284	40-D004250	Cover Hinge,A190A2-H05,ABS PA757N,Black(J91A11B5),Fuking
14	C-00004280	40-D004256	Seat Assy,A190A2-H05,ABS PA757N,Midnight(H93828B5),Hontech Precision
	C-00004285	40-D004259	Seat Assy,A190A2-H05,ABS PA757N,Black(J91A11B5),Hontech Precision

9. Block Diagram

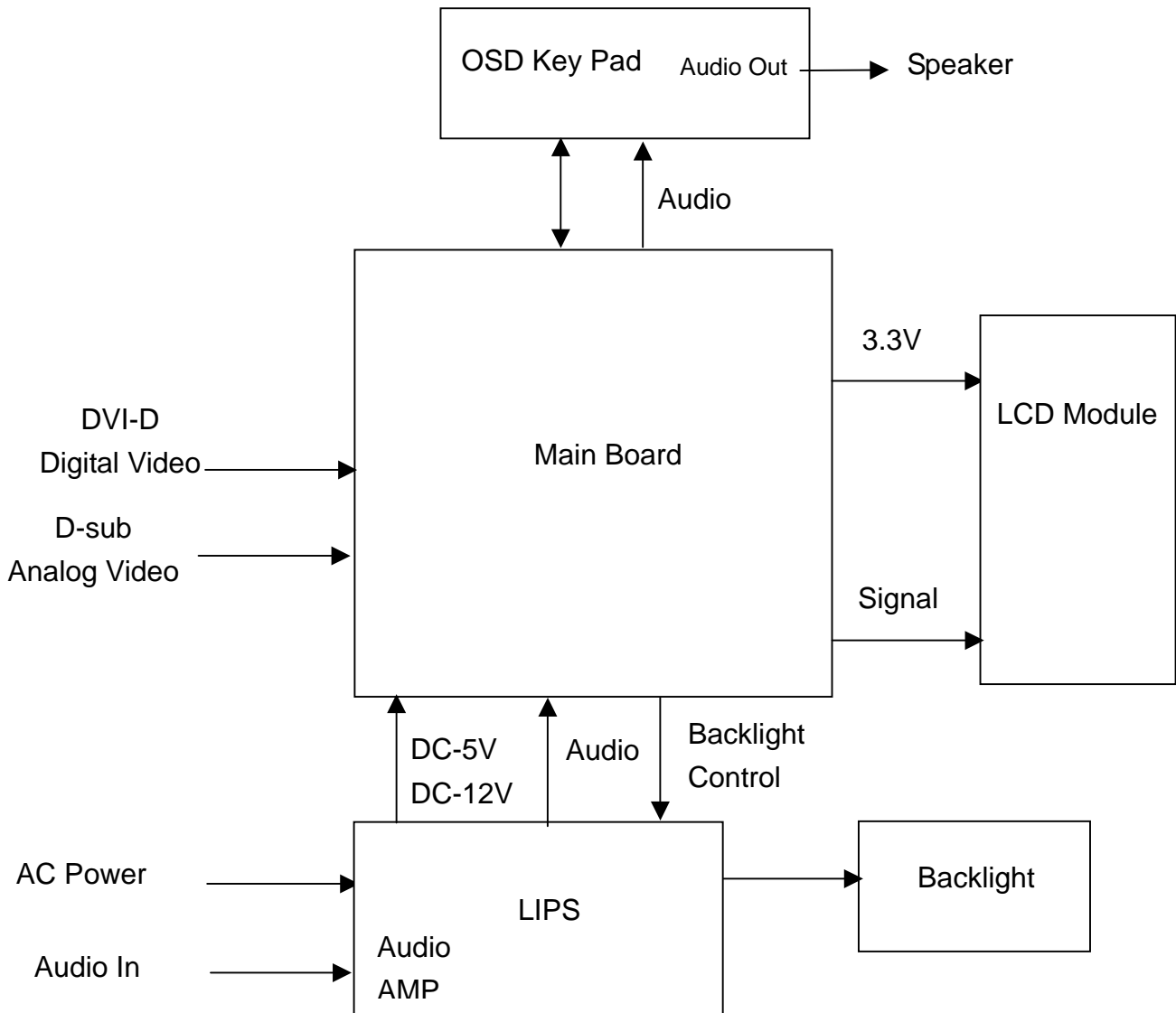

10. Schematic Diagrams

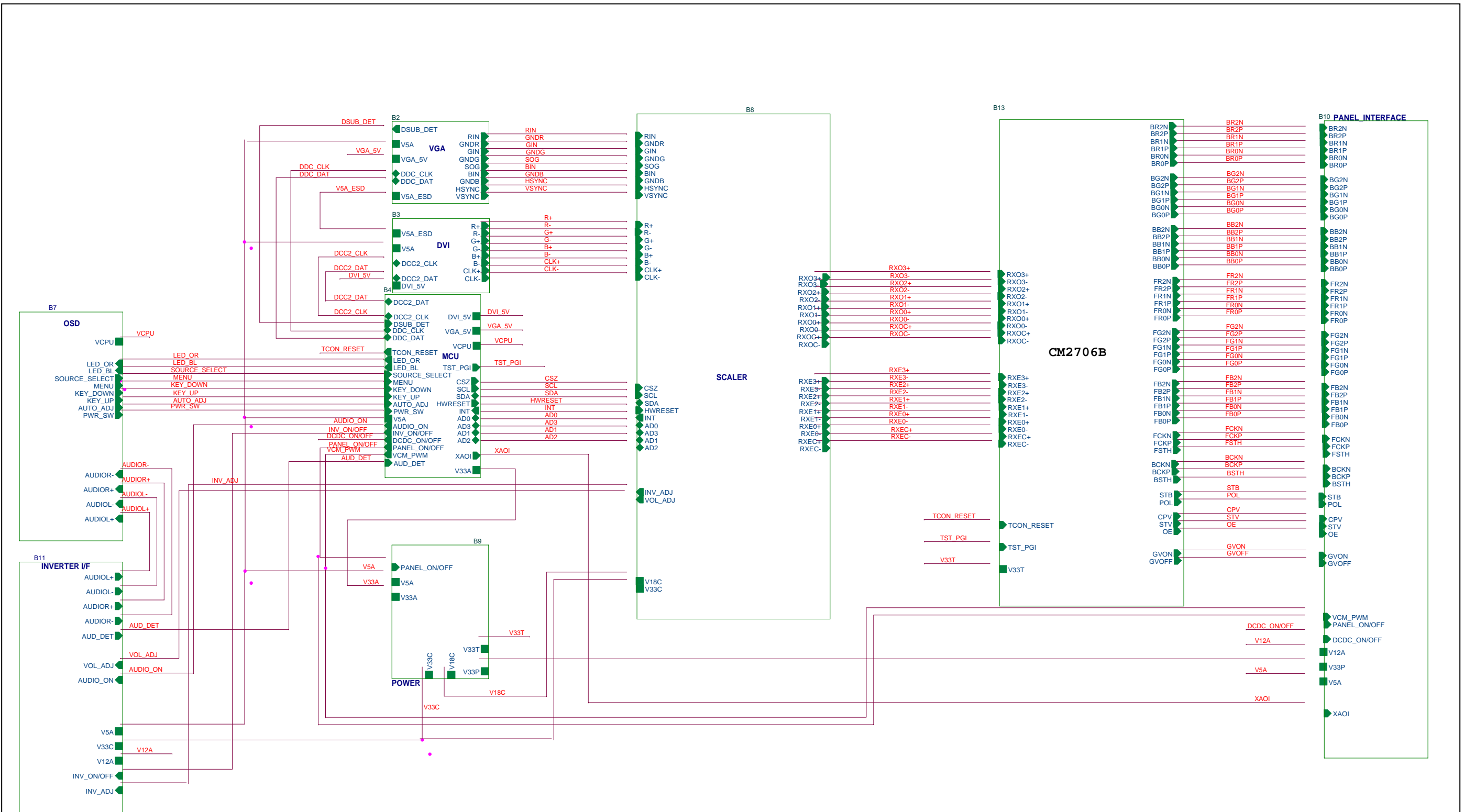

ViewSonic Corporation	
Model	TOP
Title	
Date	Rev:

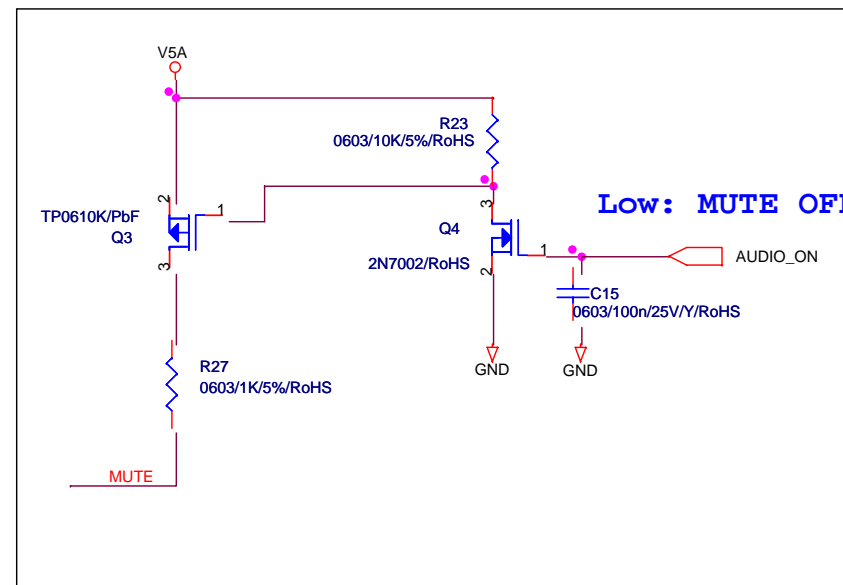
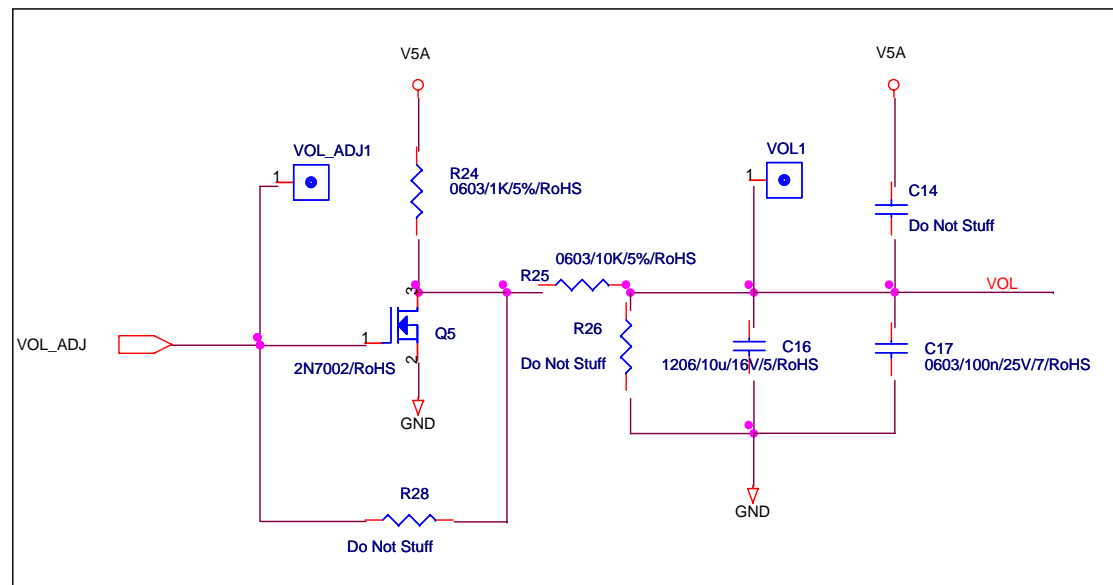
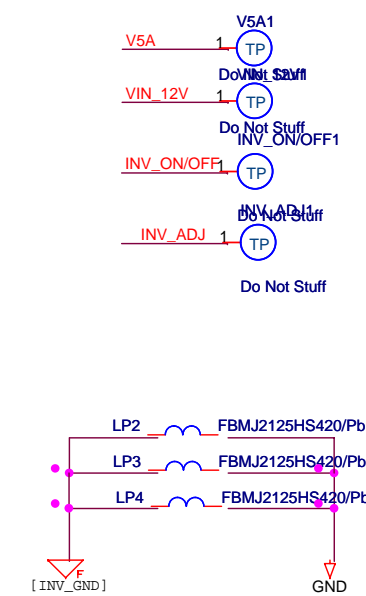
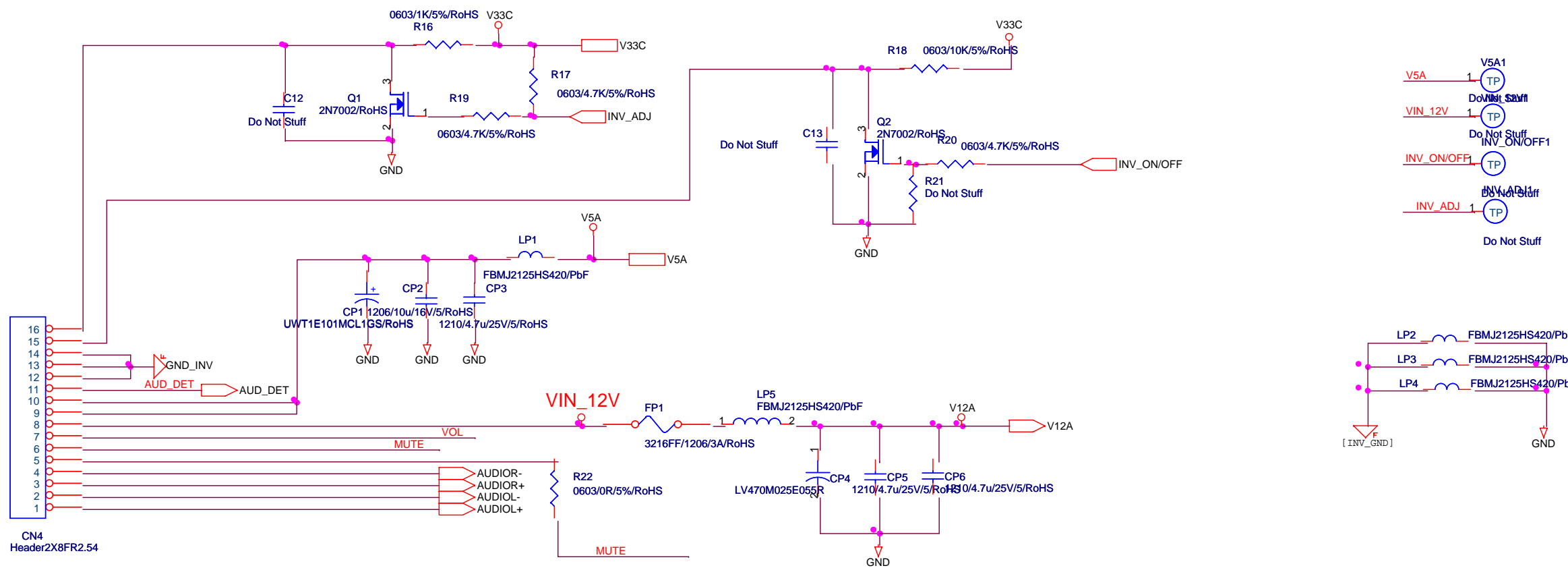

ViewSonic Corporation	
Model	INVERTER I/F
Title	
Date	Rev:

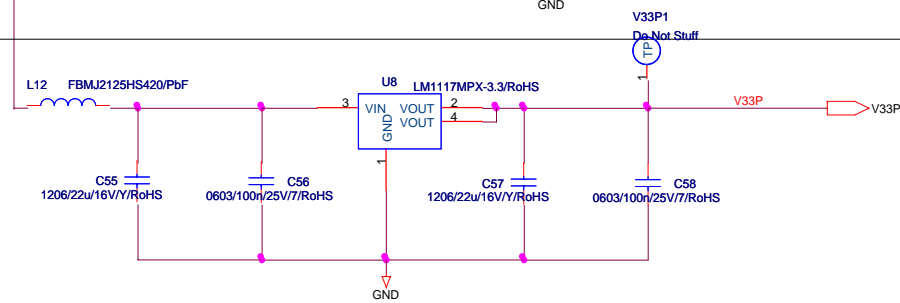
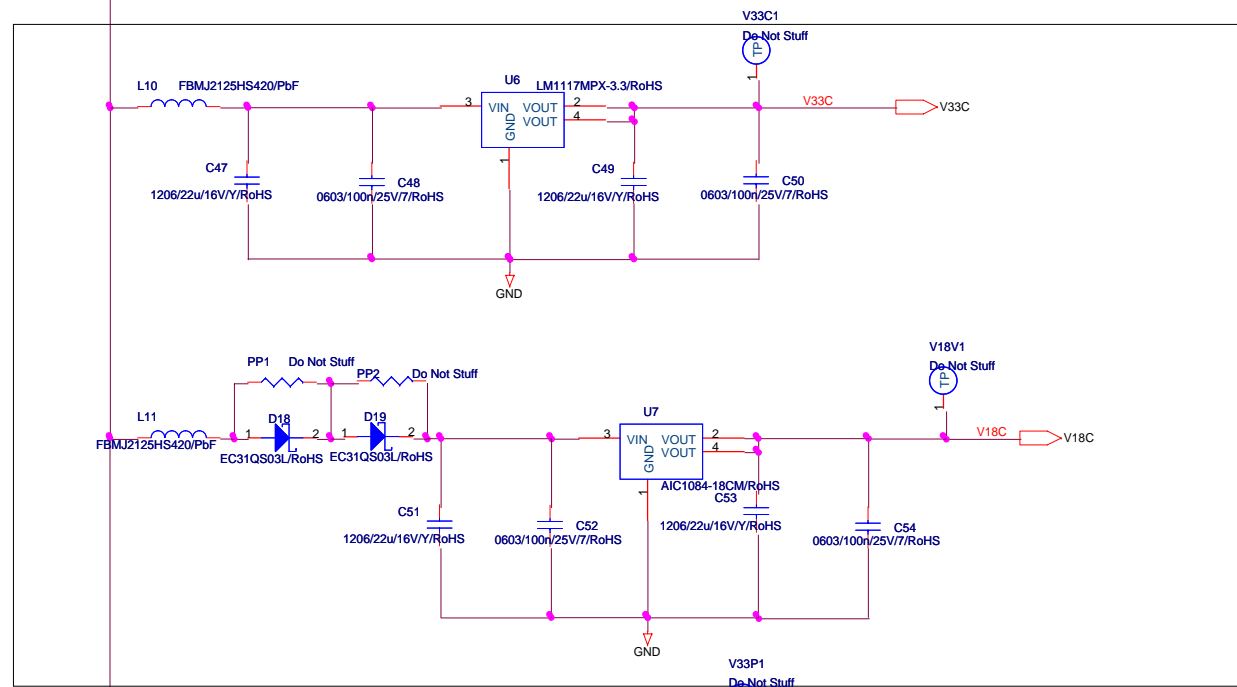
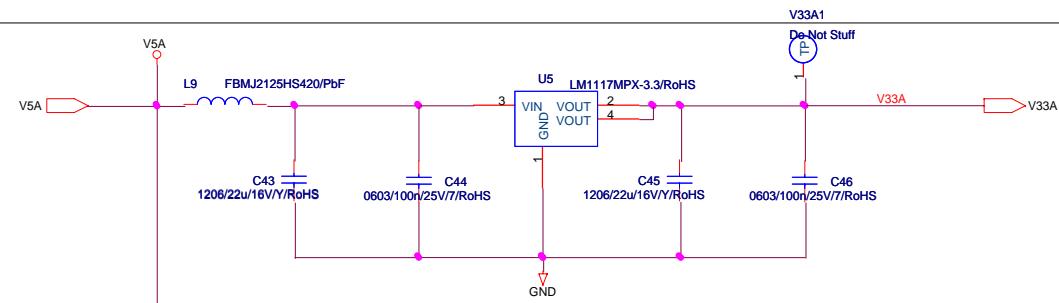
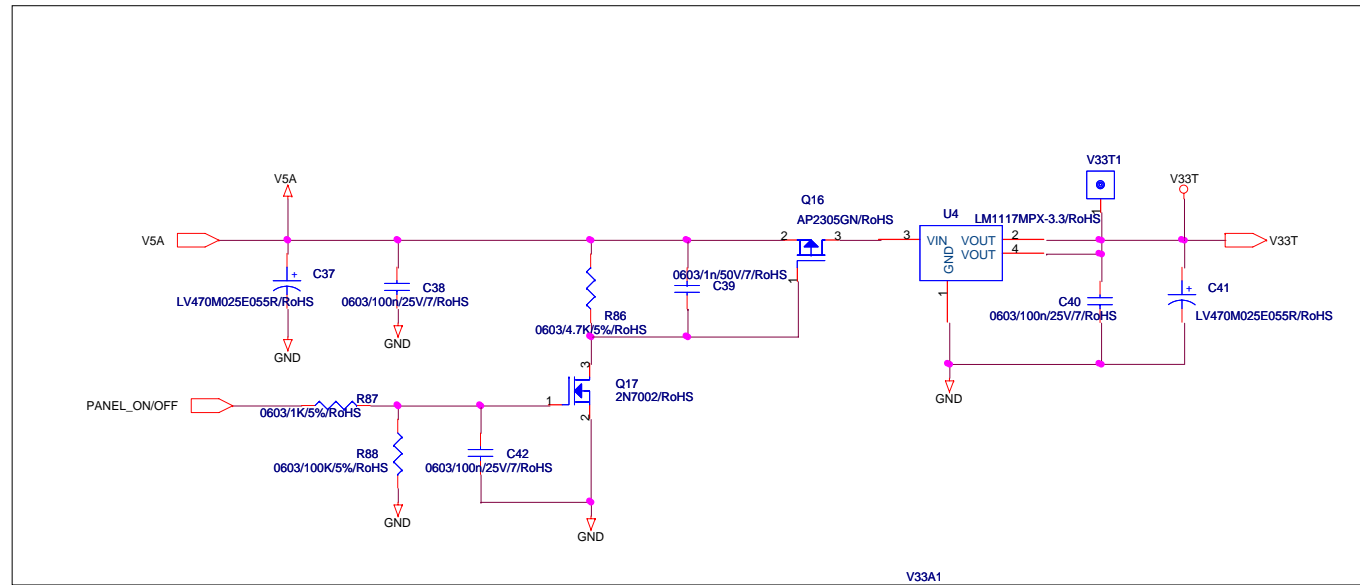

ViewSonic Corporation	
Model	POWER
Title	
Date	Rev:

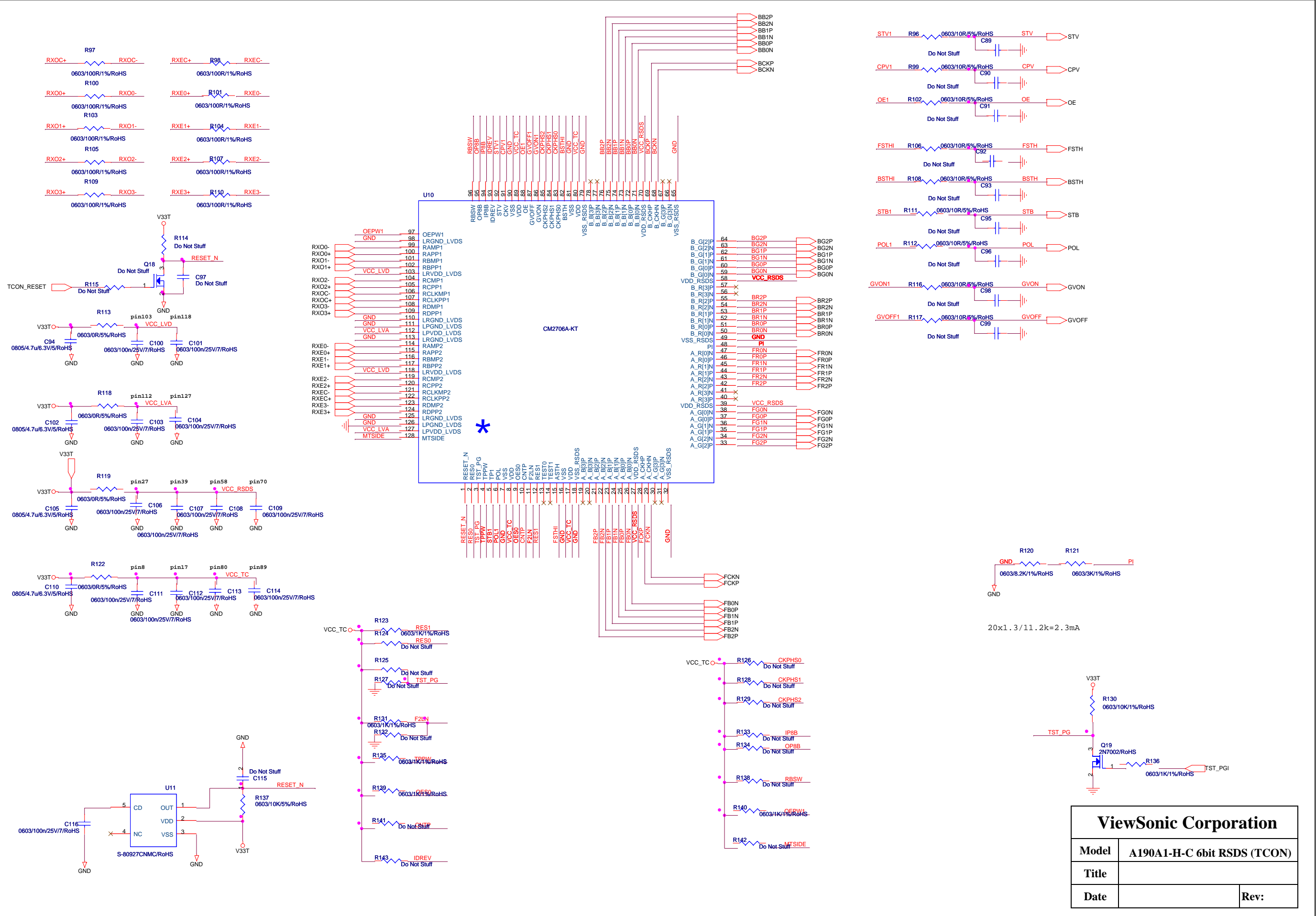

ViewSonic Corporation	
Model	A190A1-H-C 6bit RSDS (TCON)
Title	
Date	Rev:

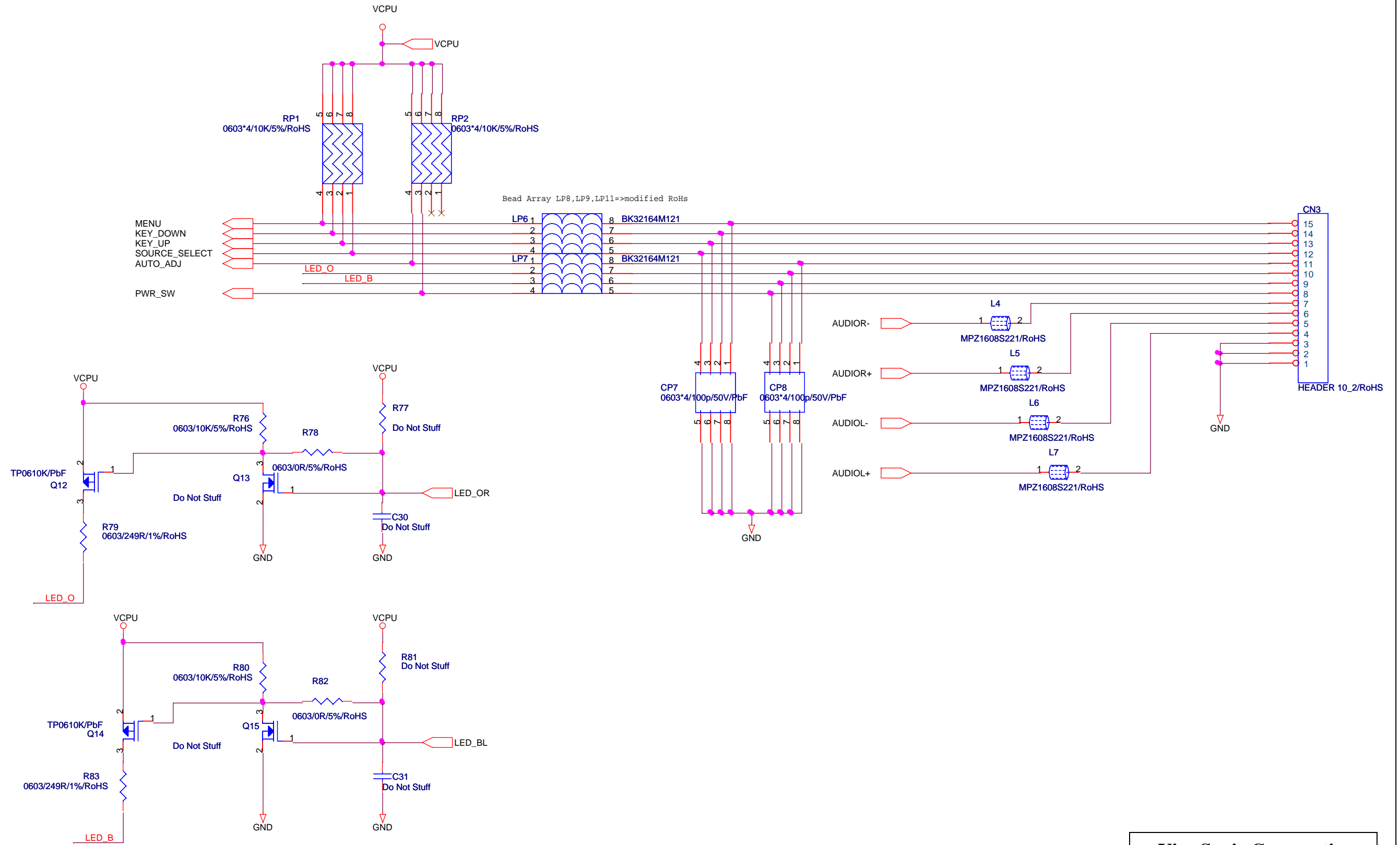

ViewSonic Corporation	
Model	OSD & AUDIO
Title	
Date	Rev:

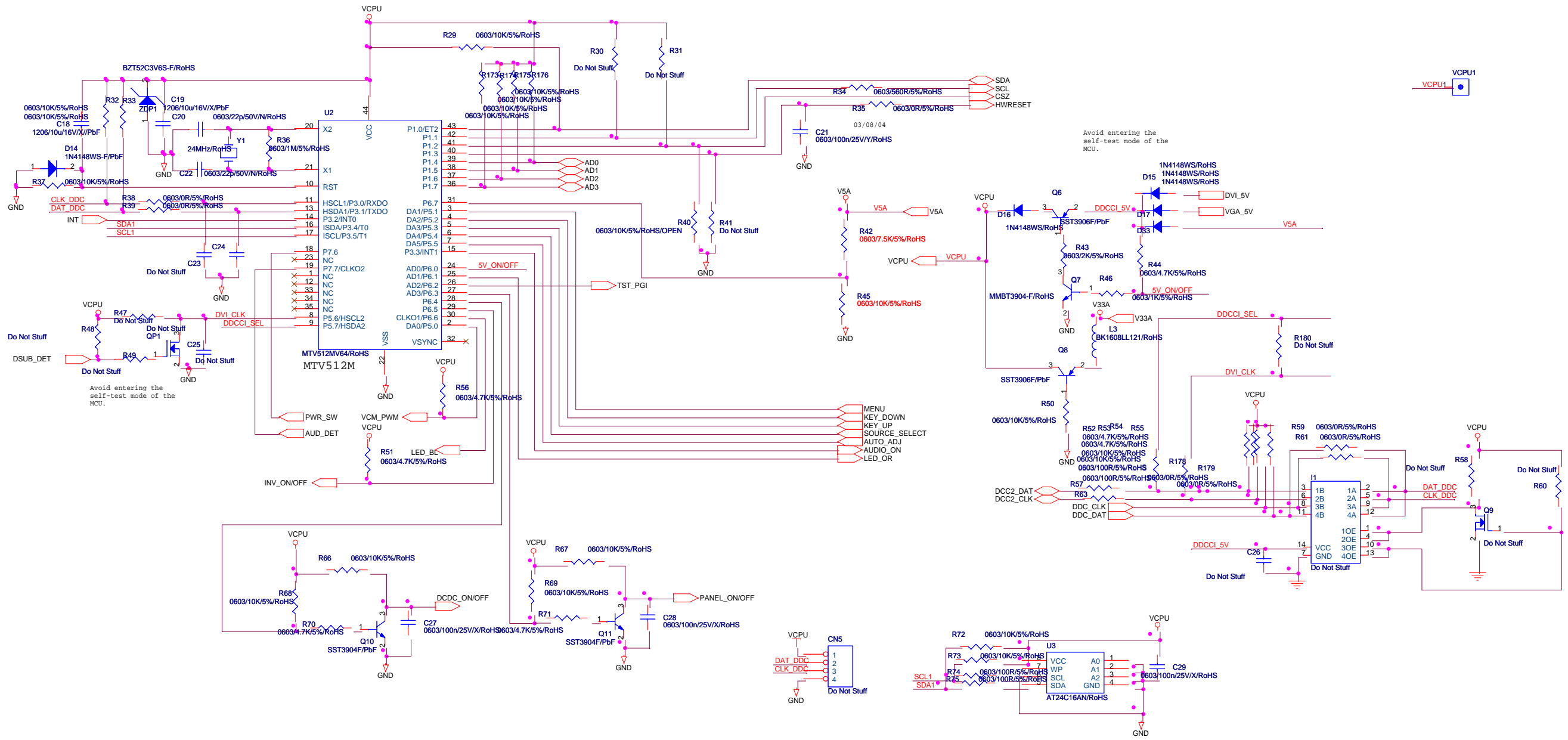

ViewSonic Corporation	
Model	MCU
Title	
Date	Rev:

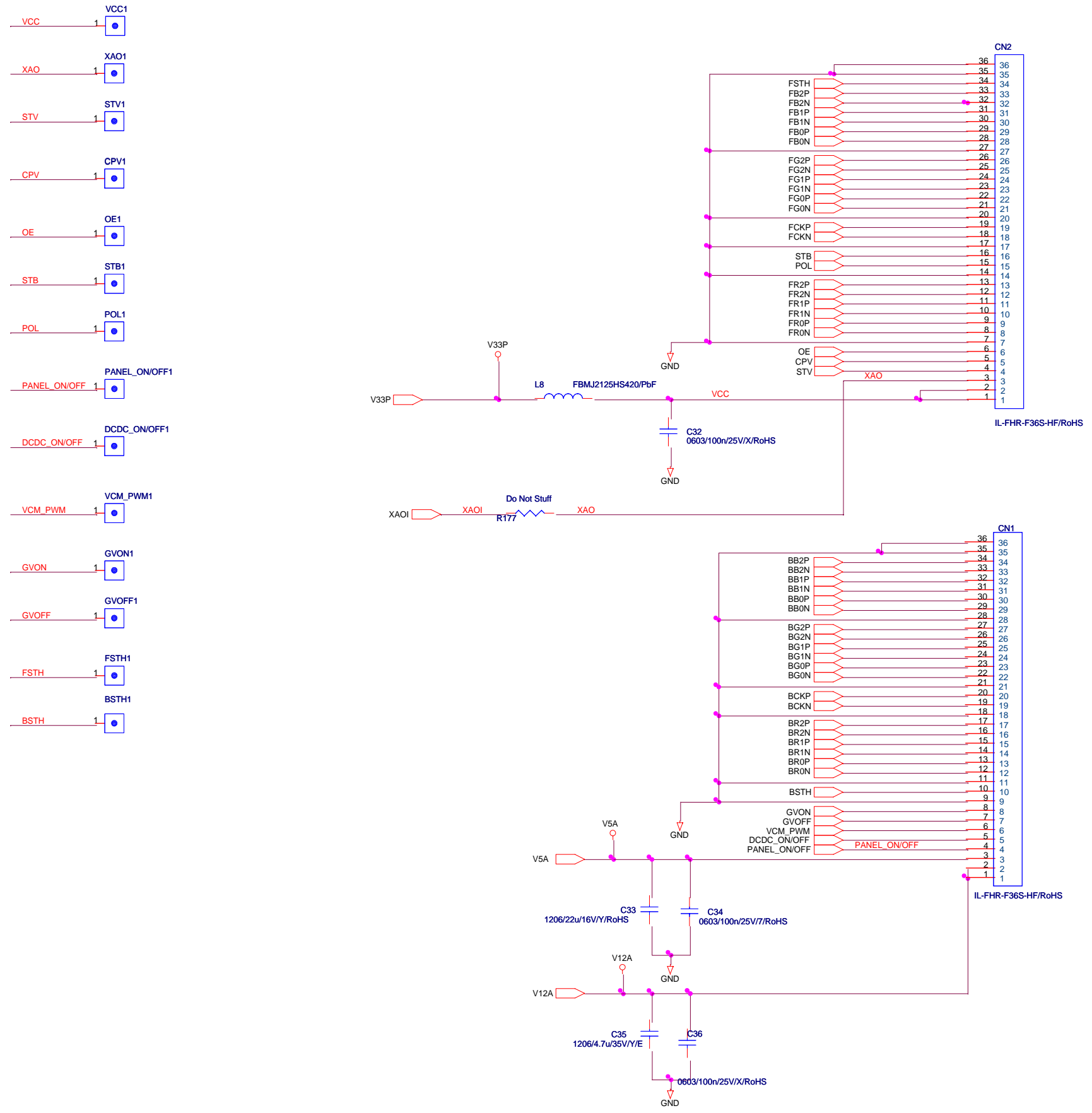

ViewSonic Corporation	
Model	PANEL I/F
Title	
Date	Rev:

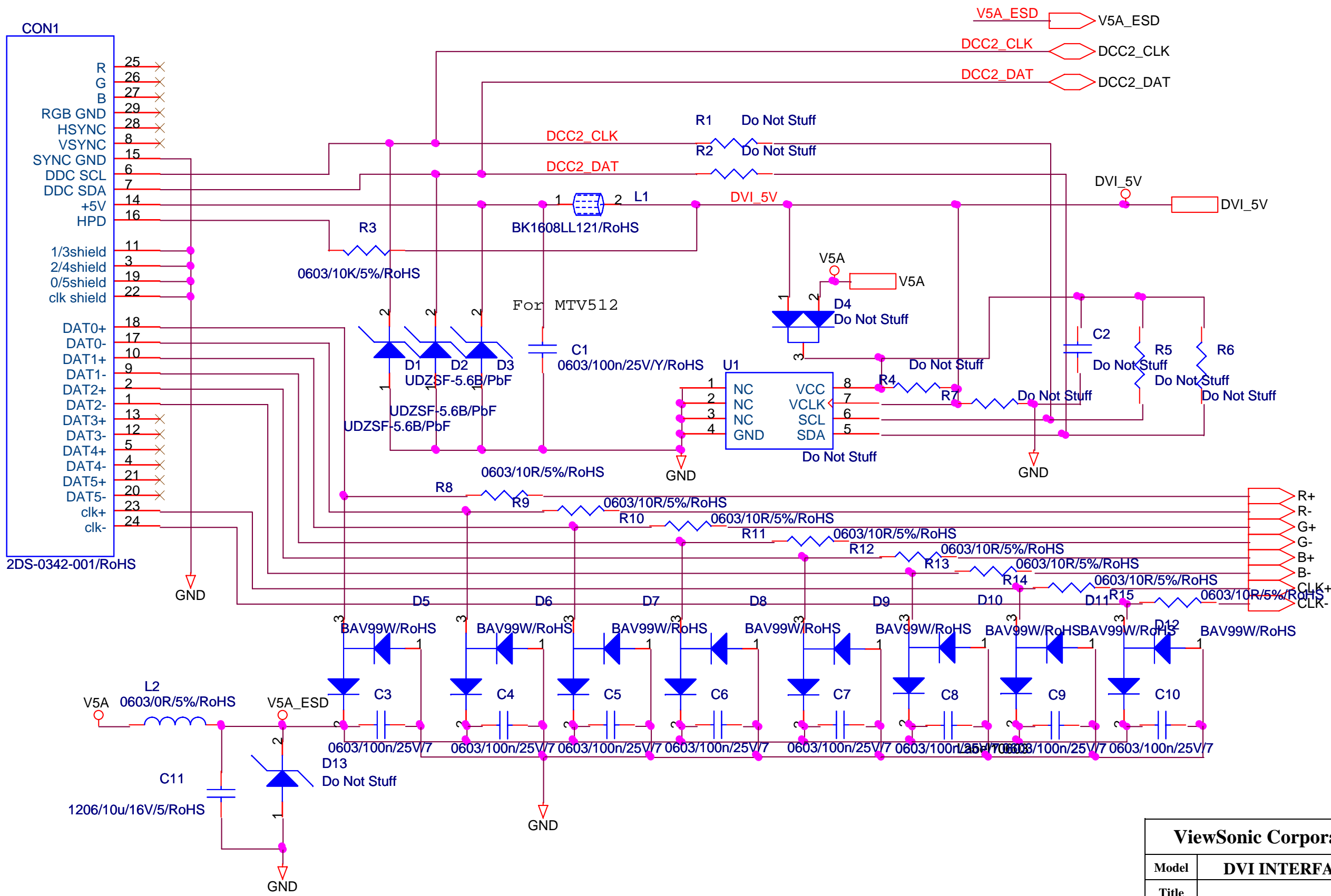

ViewSonic Corporation	
Model	DVI INTERFACE
Title	
Date	Rev:

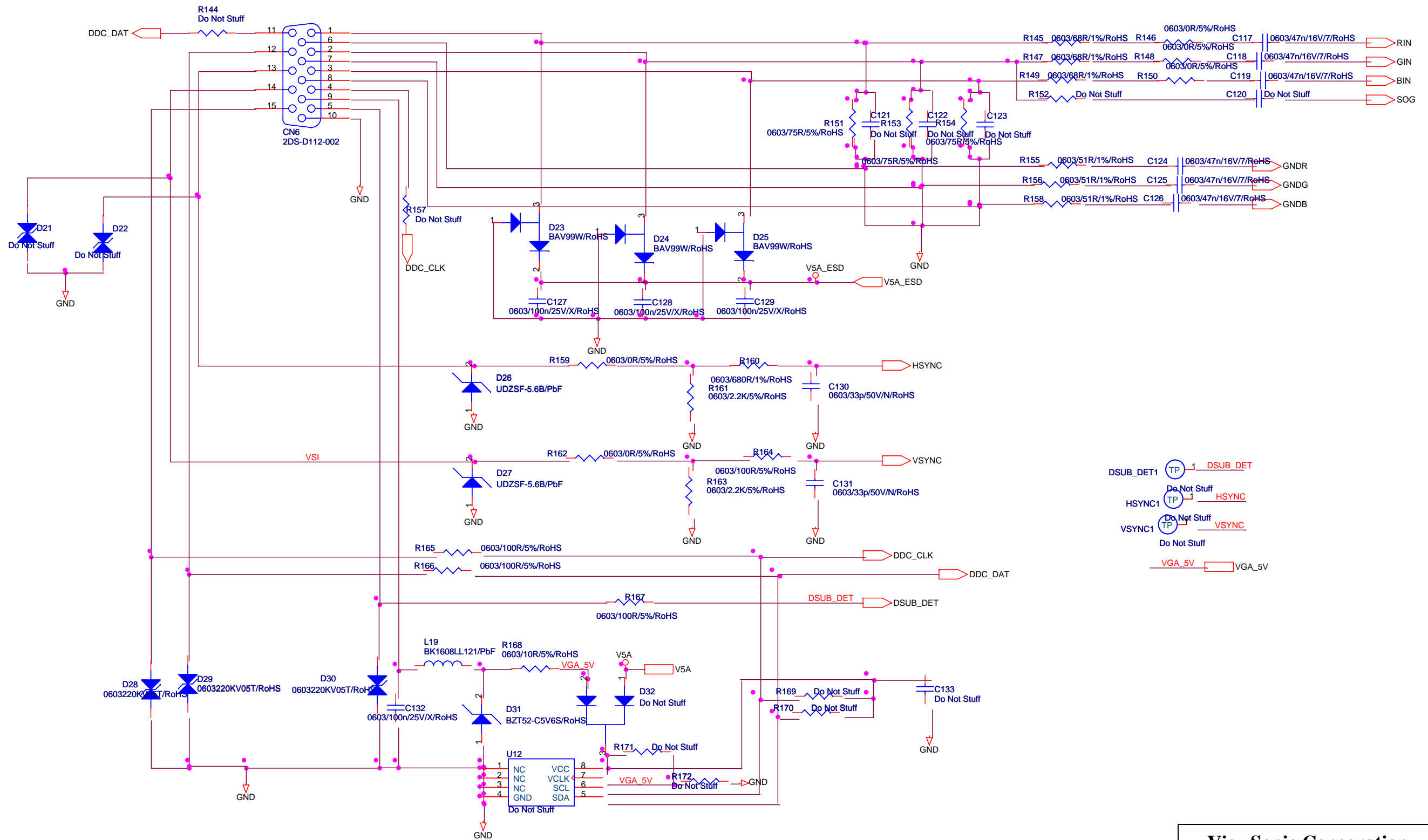

ViewSonic Corporation	
Model	VGA
Title	
Date	Rev:

11. PCB Layout Diagrams

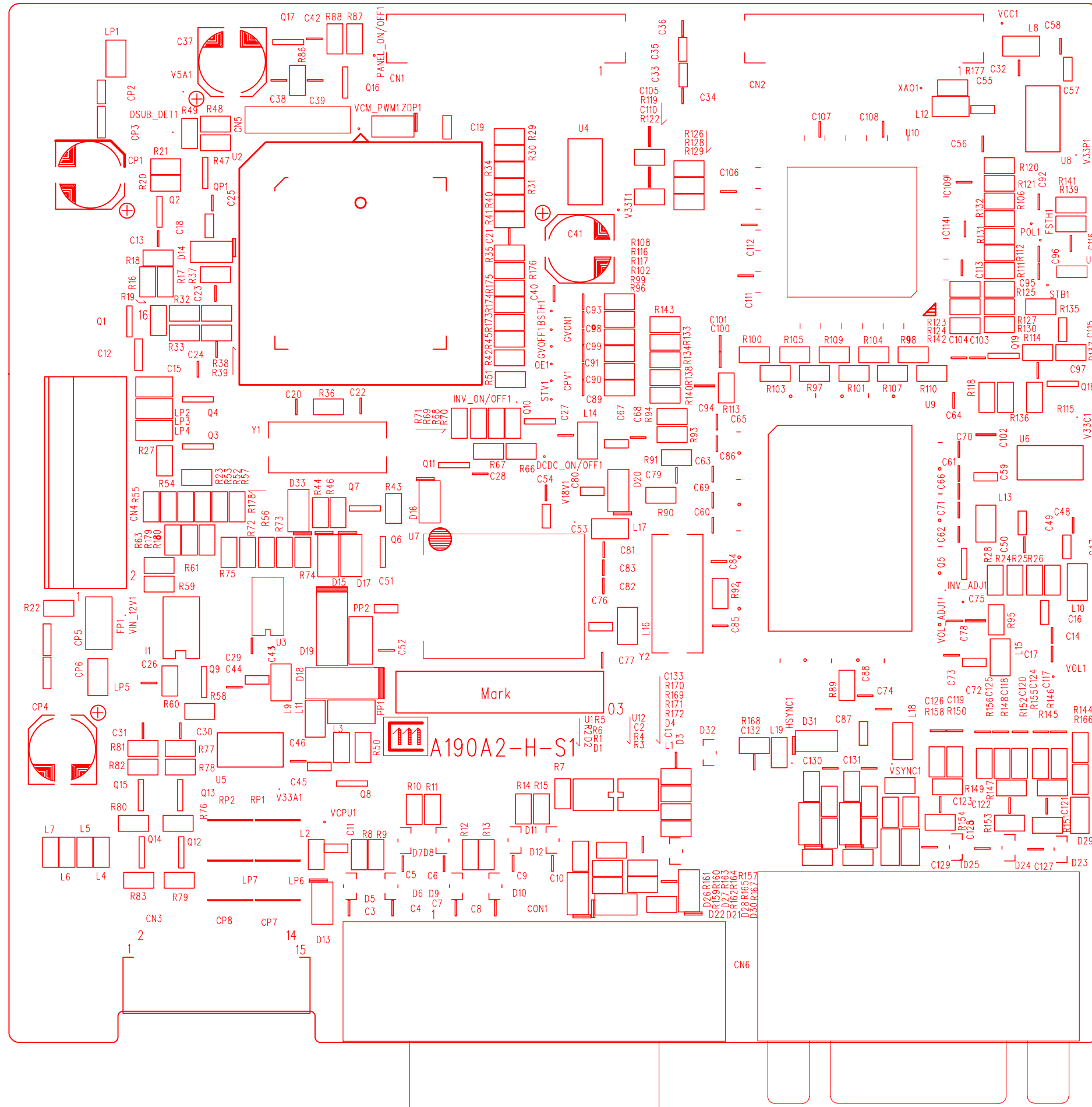

* *Reader's Response* *

Dear Readers:

Thank you in advance for your feedback on our Service Manual, which allows continuous improvement of our products. We would appreciate your completion of the Assessment Matrix below, for return to ViewSonic Corporation.

Assessment

A. What do you think about the content of this Service Manual?

<i>Unit</i>	<i>Excellent</i>	<i>Good</i>	<i>Fair</i>	<i>Bad</i>
1. Precautions and Safety Notices				
2. Specification				
3. Front Panel Function Control Description				
4. Circuit Description				
5. Adjustment Procedure				
6. Troubleshooting Flow Chart				
7. Recommended Spare Parts List				
8. Exploded Diagram and Exploded Parts List				
9. Block Diagrams				
10. Schematic Diagrams				
11. PCB Layout Diagrams				

B. Are you satisfied with this Service Manual?

<i>Item</i>	<i>Excellent</i>	<i>Good</i>	<i>Fair</i>	<i>Bad</i>
1. Service Manual Content				
2. Service Manual Layout				
3. The form and listing				

C. Do you have any other opinions or suggestions regarding this service manual?

Reader's basic data:

Name:		Title:	
Company:			
Add:			
Tel:		Fax:	
E-mail:			

After completing this form, please return it to ViewSonic Quality Assurance in the USA at facsimile 1-909-839-7943. You may also e-mail any suggestions to the Director, Quality Systems & Processes (marc.maupin@viewsonic.com)