

SERVICE MANUAL



Ver. 1.2 2011.06

AEP Model
E Model
HBD-DZ840K/DZ940K
Russian Model
HBD-DZ340M/DZ640M/DZ840M



(Photo: HBD-DZ940K)

- HBD-DZ340M/DZ640M/DZ840K/DZ840M/DZ940K are the amplifier, DVD/CD and tuner section in DAV-DZ340M/DZ640M/DZ840K/DZ840M/DZ940K.

This system incorporates with Dolby* Digital and Dolby Pro Logic adaptive matrix surround decoder and the DTS** Digital Surround System.

* Manufactured under license from Dolby Laboratories. Dolby, Pro Logic, and the double-D symbol are trademarks of Dolby Laboratories.

** Manufactured under license under U.S. Patent #'s: 5,451,942; 5,956,674; 5,974,380; 5,978,762; 6,487,535 & other U.S. and worldwide patents issued & pending. DTS and DTS Digital Surround are registered trademarks and the DTS logos and Symbol are trademarks of DTS, Inc. © 1996-2008 DTS, Inc. All Rights Reserved.

Model Name Using Similar Mechanism	HBD-DZ340/DZ340K/ DZ640K/DZ740
Mechanism Type	CDM85MB-DVBU102
Optical Pick-up Name	KHM-313CAA

SPECIFICATIONS

Amplifier Section

(DAV-DZ340M/DZ640M/DZ840M)

POWER OUTPUT (rated): Front L/Front R/Center/
Surround L/Surround R:
108 W (per channel at 3
ohms, 1 kHz, 1% THD)

POWER OUTPUT (reference):
Front L/Front R/Center/
Surround L/Surround R:
167 W (per channel at 3
ohms, 1 kHz)
Subwoofer: 165 W
(at 3 ohms, 80 Hz)

Inputs (Analog)
TV (AUDIO IN) Sensitivity: 450/250 mV
MIC Sensitivity: 1 mV
Inputs (Digital)
TV (Audio Return Channel/OPTICAL IN)
Input Stream: Dolby
Digital 5.1ch/DTS 5.1ch/
Linear PCM 2ch
(Sampling Frequency: less
than 48 kHz)

Amplifier Section (DAV-DZ840K/DZ940K)

Brazilian models:
POWER OUTPUT: Front L/Front R/Center/
Surround L/Surround R:
142 W (per channel at 3
ohms, 1 kHz, 10% THD*,
127 V)
Subwoofer: 140 W
(at 3 ohms, 80 Hz, 10%
THD*, 127 V)
* Total harmonic distortion

Other models:
POWER OUTPUT (rated): Front L/Front R/Center/
Surround L/Surround R:
108 W (per channel at 3
ohms, 1 kHz, 1% THD)

POWER OUTPUT (reference):
Front L/Front R/Center/
Surround L/Surround R:
167 W (per channel at 3
ohms, 1 kHz)
Subwoofer: 165 W (at 3
ohms, 80 Hz)

Inputs (Analog)
TV (AUDIO IN) Sensitivity: 450/250 mV
AUDIO IN Sensitivity: 250/125 mV
MIC Sensitivity: 1 mV
Inputs (Digital)
TV (Audio Return Channel/OPTICAL IN)
Input Stream: Dolby
Digital 5.1ch/DTS 5.1ch/
Linear PCM 2ch
(Sampling Frequency: less
than 48 kHz)

CD/DVD System

Laser Diode Properties
Emission Duration:
Continuous
Laser Output: Less than
44.6 μW

* This output is the value measurement at a distance
of 200 mm from the objective lens surface on the
Optical Pick-up Block with 7 mm aperture.

Signal format system
Latin American models: NTSC
Other models: NTSC/PAL

– Continued on next page –

USB Section

⚡ (USB) port:
Maximum current: 500 mA

Tuner Section

System PLL quartz-locked digital synthesizer

Tuning range

Brazilian models 87.5 MHz - 108.0 MHz
(100 kHz step)

Other models 87.5 MHz - 108.0 MHz
(50 kHz step)

Antenna (aerial) FM wire antenna (aerial)

Antenna (aerial) terminals 75 ohms, unbalanced

Video Section**Outputs**

DAV-DZ340M: VIDEO: 1 Vp-p 75 ohms
HDMI OUT: Type A (19 pin)

DAV-DZ640M/DZ840K/DZ840M/DZ940K:

VIDEO: 1 Vp-p 75 ohms

COMPONENT:

Y: 1 Vp-p 75 ohms

PB, PR: 0.7 Vp-p 75 ohms

HDMI OUT: Type A (19 pin)

General**Power requirements**

Latin American models: 110 V - 240 V AC, 50/60 Hz

Saudi Arabian models: 127 V - 240 V AC, 50/60 Hz

Other models: 220 V - 240 V AC, 50/60 Hz

Power consumption On: 160 W

Standby: 0.3 W*

* Valid when the system is in the following status:

- "DEMO" is set to "OFF."

- [CONTROL FOR HDMI] is set to [OFF].

Dimensions (approx.) 430 mm × 55 mm × 350 mm (w/h/d) incl.
projecting parts

Mass (approx.) 3.5 kg

Supported file format**MP3 (MPEG 1 Audio Layer-3)**

File Extension: mp3

Bitrate: 32 kbps - 320 kbps

Sampling frequencies: 32/44.1/48 kHz

WMA (USB device only)

File Extension: wma

Bitrate: 48 kbps - 192 kbps

Sampling frequencies: 44.1 kHz

AAC (USB device only)

File Extension: m4a

Bitrate: 48 kbps - 320 kbps

Sampling frequencies: 44.1 kHz

Xvid

File Extension: avi

Video codec: Xvid video

Bitrate: 4.854 Mbps (MAX)

Resolution/Frame rate: 720 × 480 30 fps

720 × 576 25 fps

Audio codec: MP3

MPEG4

File format: MP4 File Format

File Extension: mp4/m4v

Video codec: MPEG4 Simple Profile
(AVC is not compatible.)

Bitrate: 4 Mbps

Frame rate: 30 fps

Resolution: 720 × 576

Audio codec: AAC-LC (HE-AAC is not compatible.)

DRM: Not compatible

Design and specifications are subject to change without notice.

**SAFETY-RELATED COMPONENT WARNING!**

COMPONENTS IDENTIFIED BY MARK \triangle OR DOTTED LINE WITH MARK \triangle ON THE SCHEMATIC DIAGRAMS AND IN THE PARTS LIST ARE CRITICAL TO SAFE OPERATION. REPLACE THESE COMPONENTS WITH SONY PARTS WHOSE PART NUMBERS APPEAR AS SHOWN IN THIS MANUAL OR IN SUPPLEMENTS PUBLISHED BY SONY.

SPECIAL COMPONENT NOTICE

The components identified by mark \square contain confidential information. Strictly follow the instructions whenever the components are repaired and/or replaced.

Laser component in this product is capable of emitting radiation exceeding the limit for Class 1.

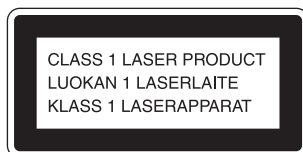

This appliance is classified as a CLASS 1 LASER product. This marking is located on the rear or bottom exterior.

CAUTION

Use of controls or adjustments or performance of procedures other than those specified herein may result in hazardous radiation exposure.

NOTES ON CHIP COMPONENT REPLACEMENT

- Never reuse a disconnected chip component.
- Notice that the minus side of a tantalum capacitor may be damaged by heat.

FLEXIBLE CIRCUIT BOARD REPAIRING

- Keep the temperature of soldering iron around 270 °C during repairing.
- Do not touch the soldering iron on the same conductor of the circuit board (within 3 times).
- Be careful not to apply force on the conductor when soldering or unsoldering.

UNLEADED SOLDER

Boards requiring use of unleaded solder are printed with the lead-free mark (LF) indicating the solder contains no lead.

(Caution: Some printed circuit boards may not come printed with the lead free mark due to their particular size)



LF : LEAD FREE MARK

Unleaded solder has the following characteristics.

- Unleaded solder melts at a temperature about 40 °C higher than ordinary solder.
Ordinary soldering irons can be used but the iron tip has to be applied to the solder joint for a slightly longer time.
Soldering irons using a temperature regulator should be set to about 350 °C.
Caution: The printed pattern (copper foil) may peel away if the heated tip is applied for too long, so be careful!
- Strong viscosity
Unleaded solder is more viscous (sticky, less prone to flow) than ordinary solder so use caution not to let solder bridges occur such as on IC pins, etc.
- Usable with ordinary solder
It is best to use only unleaded solder but unleaded solder may also be added to ordinary solder.

Self-diagnosis Function

(When letters/numbers appear in the display)

When the self-diagnosis function is activated to prevent the system from malfunctioning, a 5-character service number (e.g., C 13 50) with a combination of a letter and 4 digits appears on the TV screen or front panel display. In this case, check the following table.

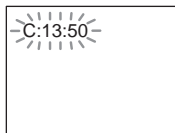

First 3 characters of the service number	Cause and/or corrective action
C 13	The disc is dirty. ➔Clean the disc with a soft cloth.
E XX (XX is a number)	To prevent a malfunction, the system has performed the self-diagnosis function. ➔Contact your nearest Sony dealer or local authorized Sony service facility and give the 5-character service number. Example: E 61 10

When the version number appears on the TV screen

When you turn on the system, the version number [VER.X.XX] (X is a number) may appear on the TV screen. Although this is not a malfunction and for Sony service use only, normal system operation will not be possible. Turn off the system, and then turn on the system again to operate.



MODEL IDENTIFICATION

– Back Panel –

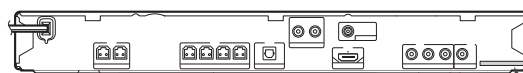

Parts No.

Model	Part No.
DZ840K: E3	4-267-102-5□
DZ840K: E15	4-267-102-6□
DZ940K: E3	4-267-102-7□
DZ940K: E15	4-267-102-8□
DZ840K: E12	4-267-103-7□
DZ840K: EA	4-267-103-8□
DZ840K: SP	4-267-103-9□
DZ340M: RU	4-267-104-0□
DZ640M: RU	4-267-104-1□
DZ840M: RU	4-267-104-2□
DZ640M: TH	4-267-105-0□
DZ840M: TH	4-267-105-2□
DZ940K: EA	4-267-105-3□
DZ940K: SP	4-267-105-4□
DZ840K: PH	4-267-105-6□
DZ840K: AEP	4-267-105-8□
DZ940K: AEP	4-267-105-9□

- Abbreviation
 - E3 : 240V AC area in E model
 - E12 : 220 – 240V AC area in E model
 - E15 : Iranian model
 - EA : Saudi Arabia model
 - PH : Philippines model
 - RU : Russian model
 - SP : Singapore model
 - TH : Thai model

TABLE OF CONTENTS

1. SERVICING NOTES	6	5-9. Schematic Diagram –MAIN Section (2/9)–	32
2. DISASSEMBLY		5-10. Schematic Diagram –MAIN Section (3/9)–	33
2-1. Case	9	5-11. Schematic Diagram –MAIN Section (4/9)–	34
2-2. Loading Panel	10	5-12. Schematic Diagram –MAIN Section (5/9)–	35
2-3. Front Panel Section	10	5-13. Schematic Diagram –MAIN Section (6/9)–	36
2-4. KEY Board, POWER KEY Board, LED Board	11	5-14. Schematic Diagram –MAIN Section (7/9)–	37
2-5. PANEL Board, USB Board.....	11	5-15. Schematic Diagram –MAIN Section (8/9)–	38
2-6. ALC Board (DZ340M/DZ640M/DZ840M)	12	5-16. Schematic Diagram –MAIN Section (9/9)–	39
2-7. Back Panel Section	12	5-17. Printed Wiring Board –IO Section–	40
2-8. MAIN Board	13	5-18. Schematic Diagram –IO Section–	41
2-9. POWER Board.....	13	5-19. Printed Wiring Boards	
2-10. DVD Mechanism Deck Section.....	14	–KEY, POWER KEY, LED Section–	42
2-11. Tray	14	5-20. Schematic Diagram	
2-12. Belt.....	15	–KEY, POWER KEY, LED Section–	43
2-13. MS-203 Board.....	15	5-21. Printed Wiring Boards	
2-14. Base Unit.....	16	–ALC, USB, MS-203 Section–.....	44
2-15. Optical Pick-up	16	5-22. Schematic Diagram –ALC, USB Section–	45
3. TEST MODE	17	5-23. Printed Wiring Board –PANEL Section–	46
4. ELECTRICAL ADJUSTMENTS	21	5-24. Schematic Diagram –PANEL Section–	47
5. DIAGRAMS		5-25. Printed Wiring Board –POWER Section–	48
5-1. Block Diagram –RF Section–	23	5-26. Schematic Diagram –POWER Section–	49
5-2. Block Diagram –VIDEO Section–	24	6. EXPLODED VIEWS	
5-3. Block Diagram –AUDIO Section–	25	6-1. Overall Section	63
5-4. Block Diagram –AMP Section–	26	6-2. Front Panel Section.....	64
5-5. Block Diagram –POWER Section–	27	6-3. Front Boards Section	65
5-6. Printed Wiring Board –MAIN Section (1/2)–.....	29	6-4. Back Panel Section	66
5-7. Printed Wiring Board –MAIN Section (2/2)–.....	30	6-5. Chassis Section	67
5-8. Schematic Diagram –MAIN Section (1/9)–	31	6-6. DVD Mechanism Deck Section (CDM85MB-DVBU102).....	68
		7. ELECTRICAL PARTS LIST	69

SECTION 1 SERVICING NOTES

NOTES ON HANDLING THE OPTICAL PICK-UP BLOCK OR BASE UNIT

The laser diode in the optical pick-up block may suffer electrostatic break-down because of the potential difference generated by the charged electrostatic load, etc. on clothing and the human body. During repair, pay attention to electrostatic break-down and also use the procedure in the printed matter which is included in the repair parts.

The flexible board is easily damaged and should be handled with care.

NOTES ON LASER DIODE EMISSION CHECK

The laser beam on this model is concentrated so as to be focused on the disc reflective surface by the objective lens in the optical pickup block. Therefore, when checking the laser diode emission, observe from more than 30 cm away from the objective lens.

LASER DIODE AND FOCUS SEARCH

1. Open the case and turn POWER on with no disc inserted.
2. Confirm that the following operation is performed while observing the objecting lens from the clearance of DVD mechanism deck.
 - 1) Confirm that laser beam is spread.
 - 2) Up and down motion of the objective lens. (2 times)

DISC TRAY LOCK

The disc tray lock function for the antitheft of an demonstration disc in the store is equipped.

Setting Procedure :

1. Press the [I/⏻] button to turn the set on.
2. Press the [FUNCTION] button to set DVD/CD function.
3. Insert a disc.
4. Press the [■] button and the [▲] button simultaneously for five seconds.
5. The message "LOCKED" is displayed and the tray is locked.

Releasing Procedure :

1. Press the [■] button and the [▲] button simultaneously for five seconds again.
2. The message "UNLOCKED" is displayed and the tray is unlocked.

Note: When "LOCKED" is displayed, the tray lock is not released by turning power on/off with the [I/⏻] button.

On cleaning discs, disc/lens cleaners

- Do not use cleaning discs or disc/lens cleaners (including wet or spray types). These may cause the apparatus to malfunction.

IMPORTANT NOTICE

Caution: This system is capable of holding a still video image or on-screen display image on your television screen indefinitely. If you leave the still video image or on-screen display image displayed on your TV for an extended period of time you risk permanent damage to your television screen.

Projection televisions are especially susceptible to this.

How to open the disc table when power switch turns off
Insert a tapering driver into the aperture of the unit bottom, and slide it in the direction of the arrow.

Insert a screwdriver from between the front panel and the chassis and slide the rod in the direction of the arrow.

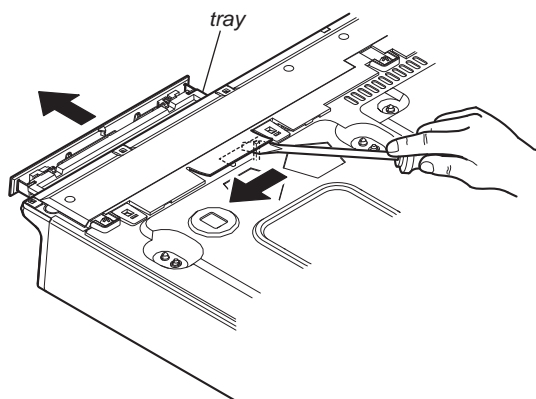

Precaution when installing a new OP unit/
Precaution before unsoldering the static electricity prevention solder bridge

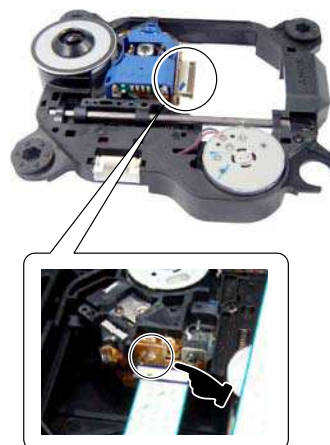

When installing a new OP unit, be sure to connect the flexible printed circuit board first of all before removing the static electricity prevention solder bridge by unsoldering. Remove the static electricity prevention solder bridge by unsoldering after the flexible printed circuit board has already been connected.

(Do not remove nor unsolder the solder bridge as long as the OP unit is kept standalone.)

Discharge the charged electricity in capacitors to prevent electric shock as follows
When disassembling the machine, be sure to discharge the charged electricity in the following capacitors.
Use a resistor of 800 ohms, 2 Watts for discharging the following capacitors.

POWER board

C903: 390V

C932, C933, C934, CN904: 30V

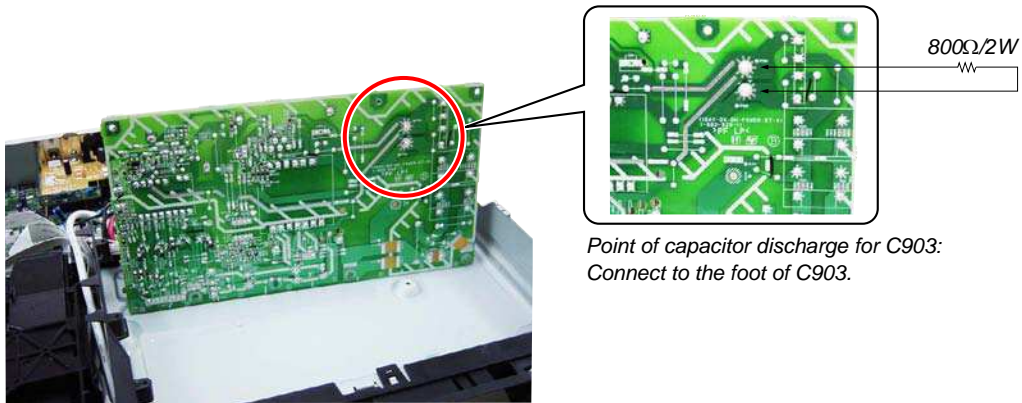

CDM SERVICE POSITION

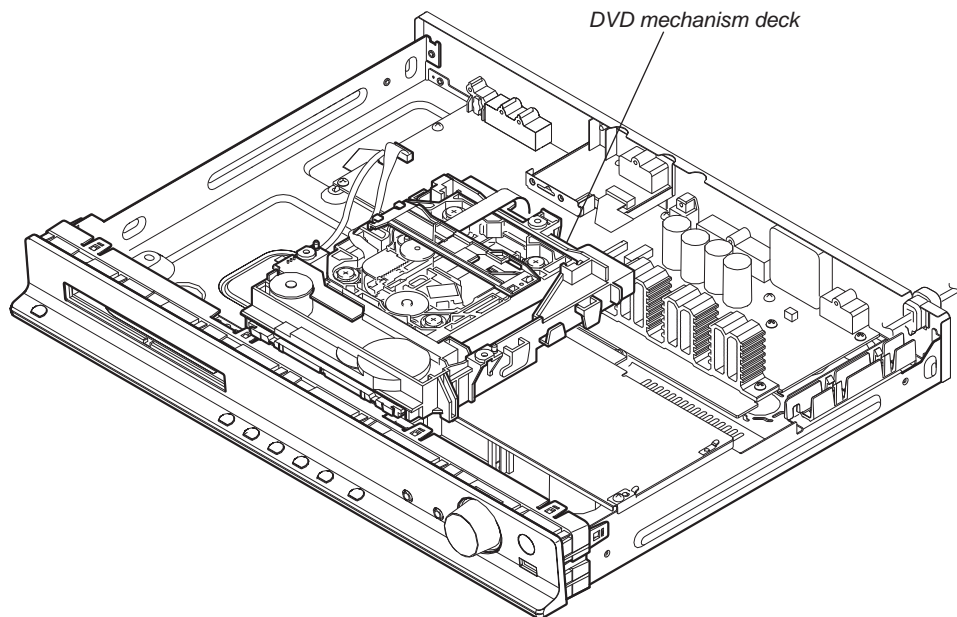

HBD-DZ340M/DZ640M/DZ840K/DZ840M/DZ940K

SECTION 2 DISASSEMBLY

- This set can be disassembled in the order shown below.

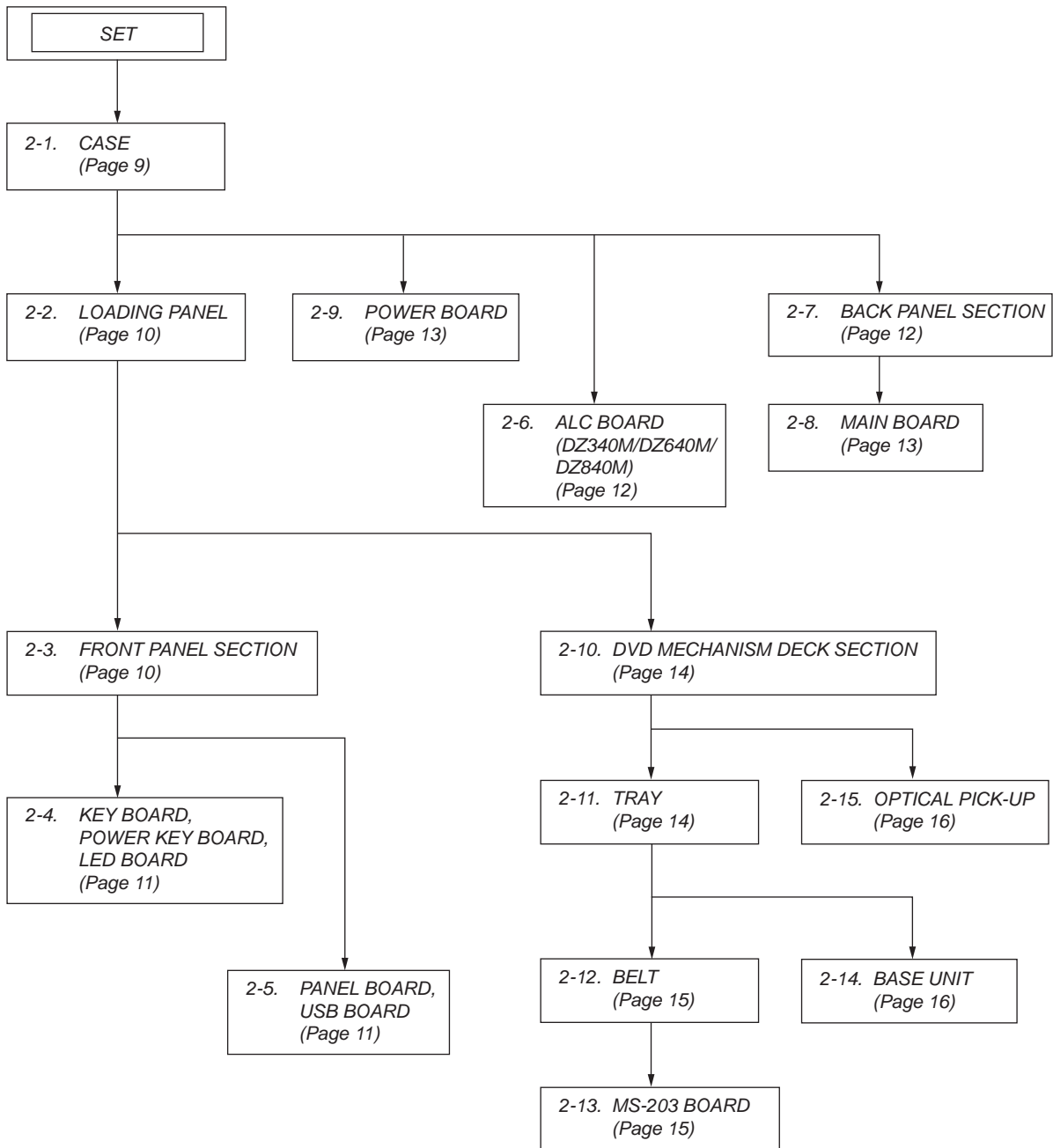

Note: Follow the disassembly procedure in the numerical order given.

2-1. CASE

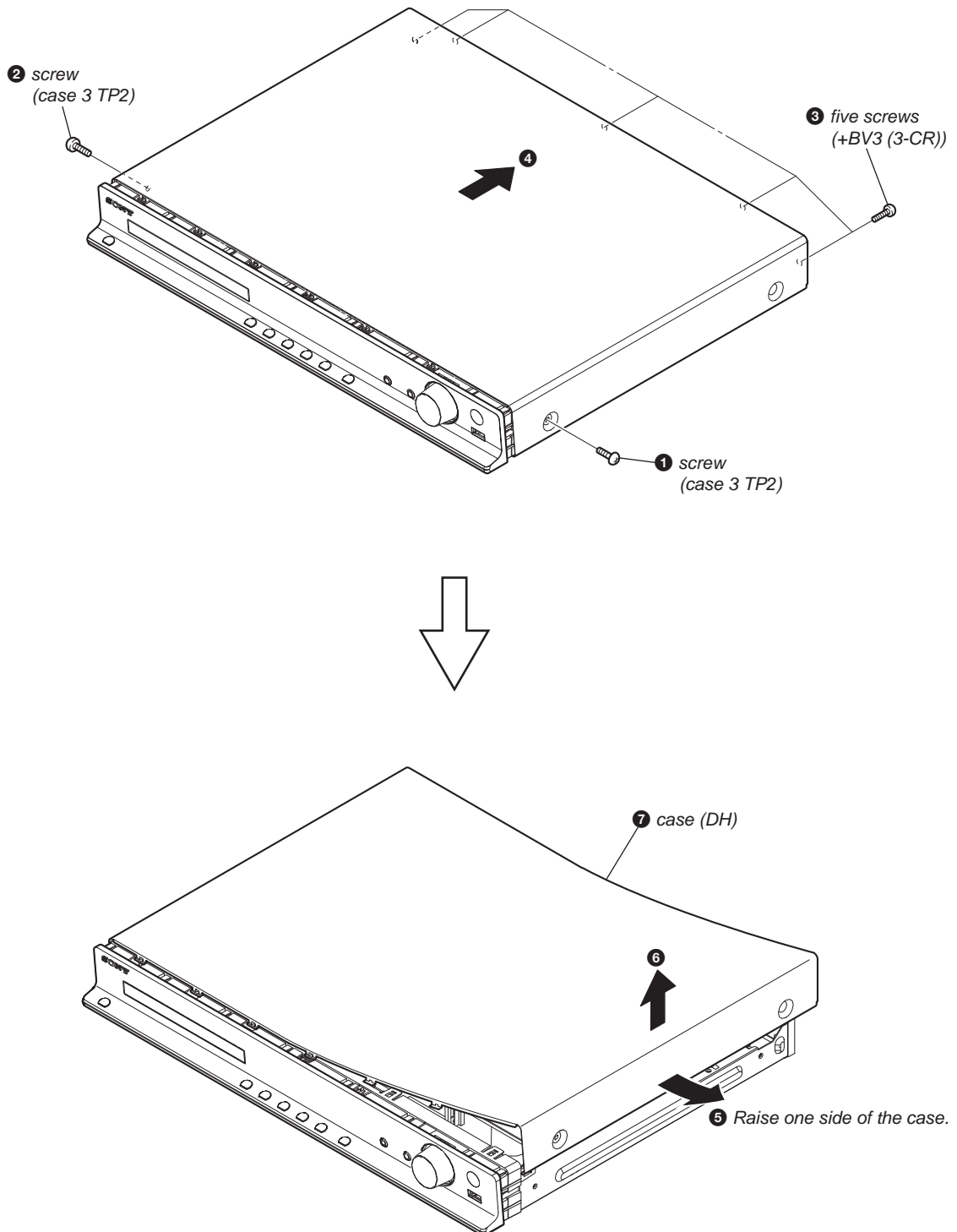

2-2. LOADING PANEL

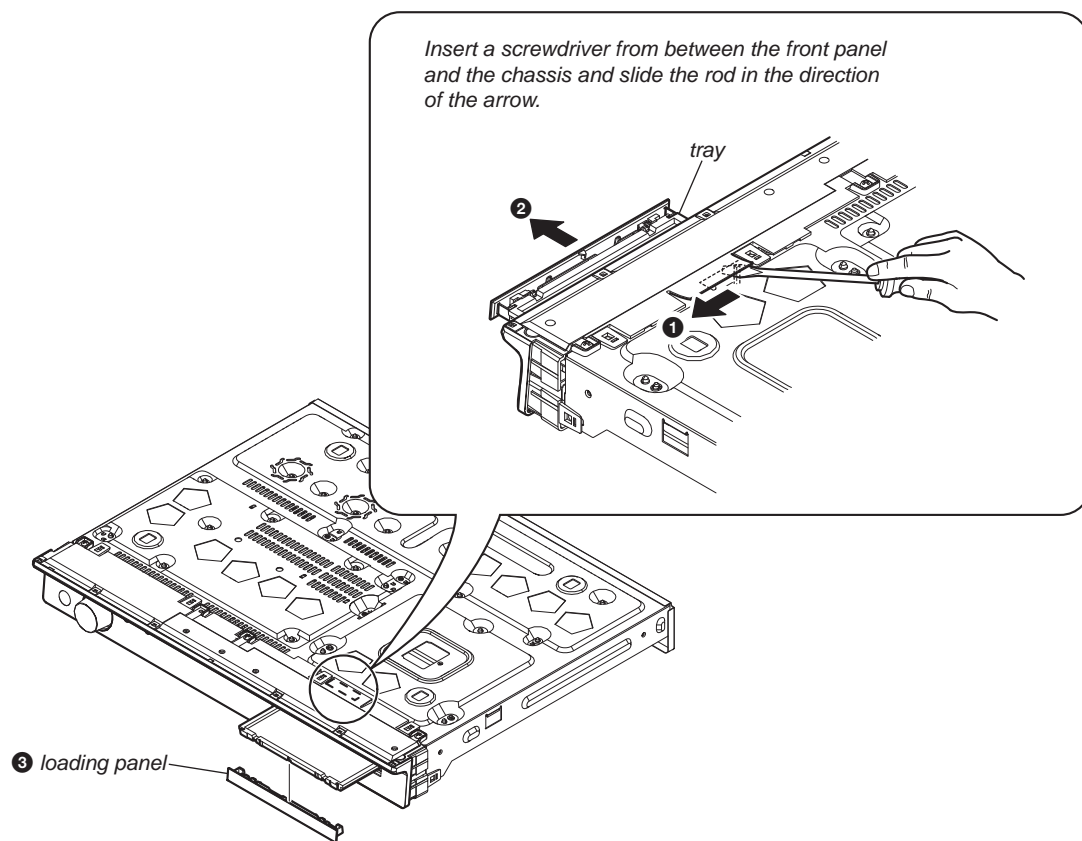

2-3. FRONT PANEL SECTION

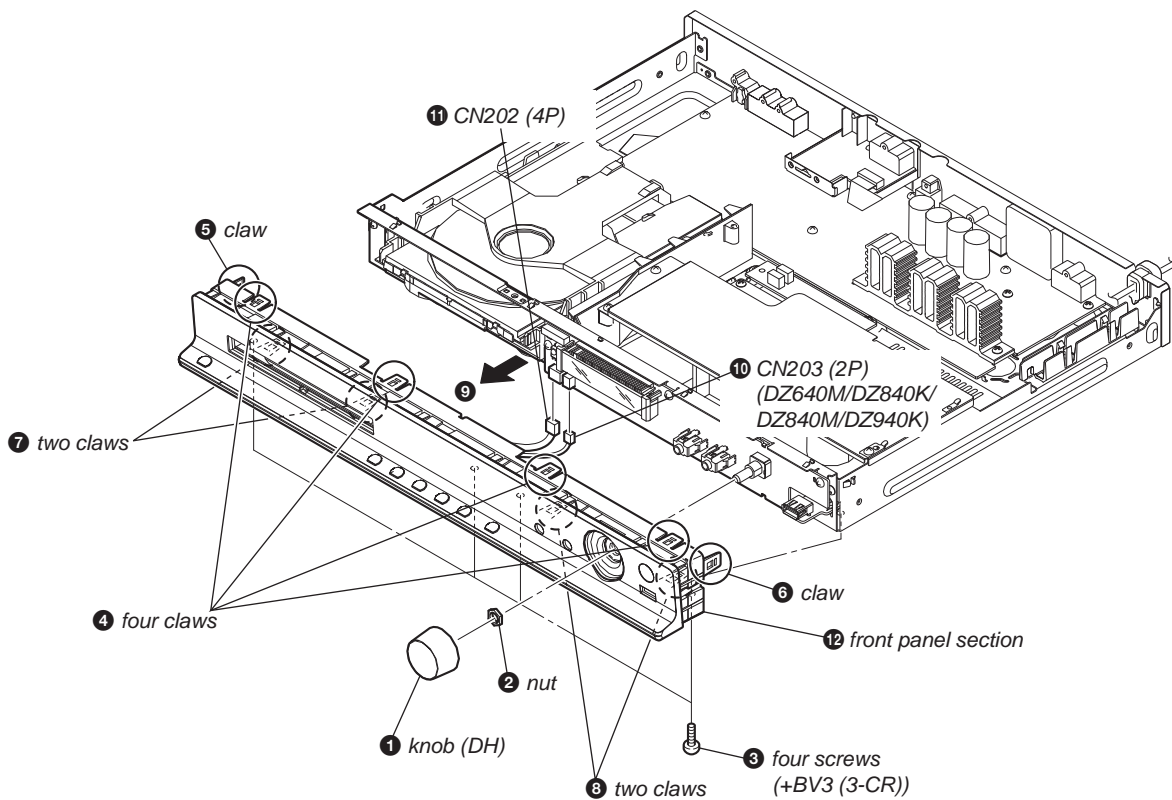

2-4. KEY BOARD, POWER KEY BOARD, LED BOARD

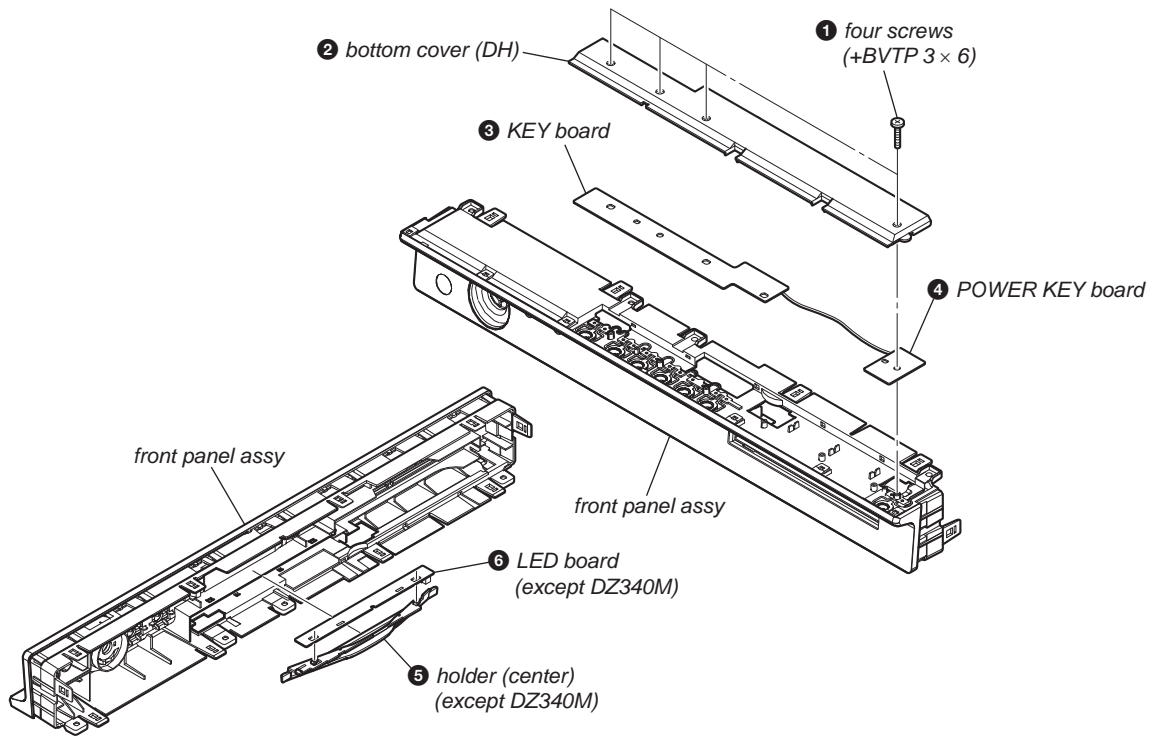

2-5. PANEL BOARD, USB BOARD

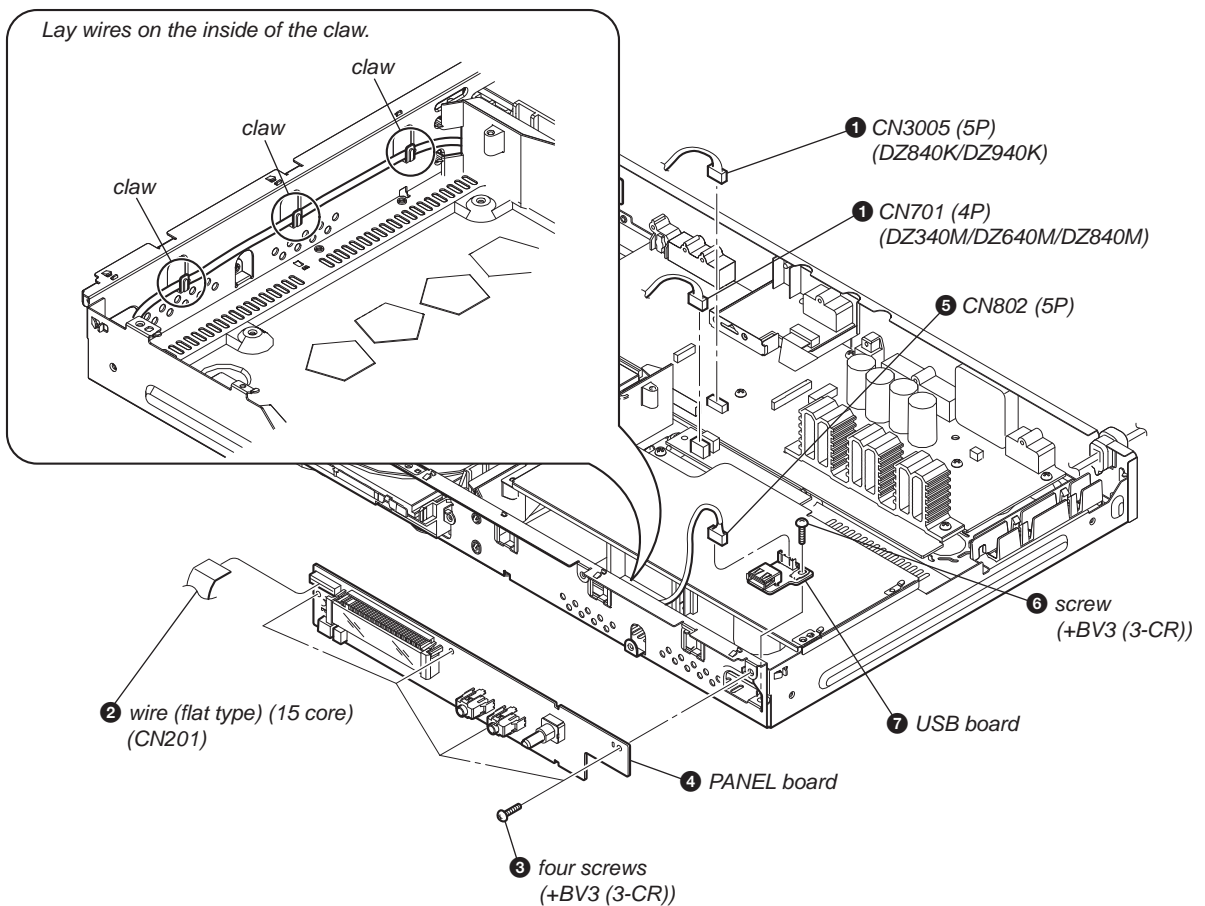

2-6. ALC BOARD (DZ340M/DZ640M/DZ840M)

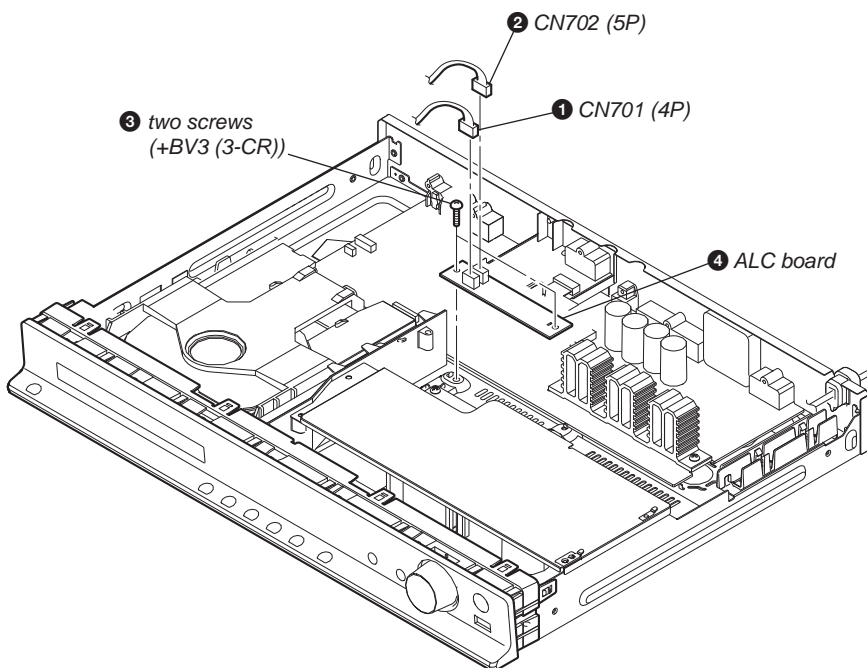

2-7. BACK PANEL SECTION

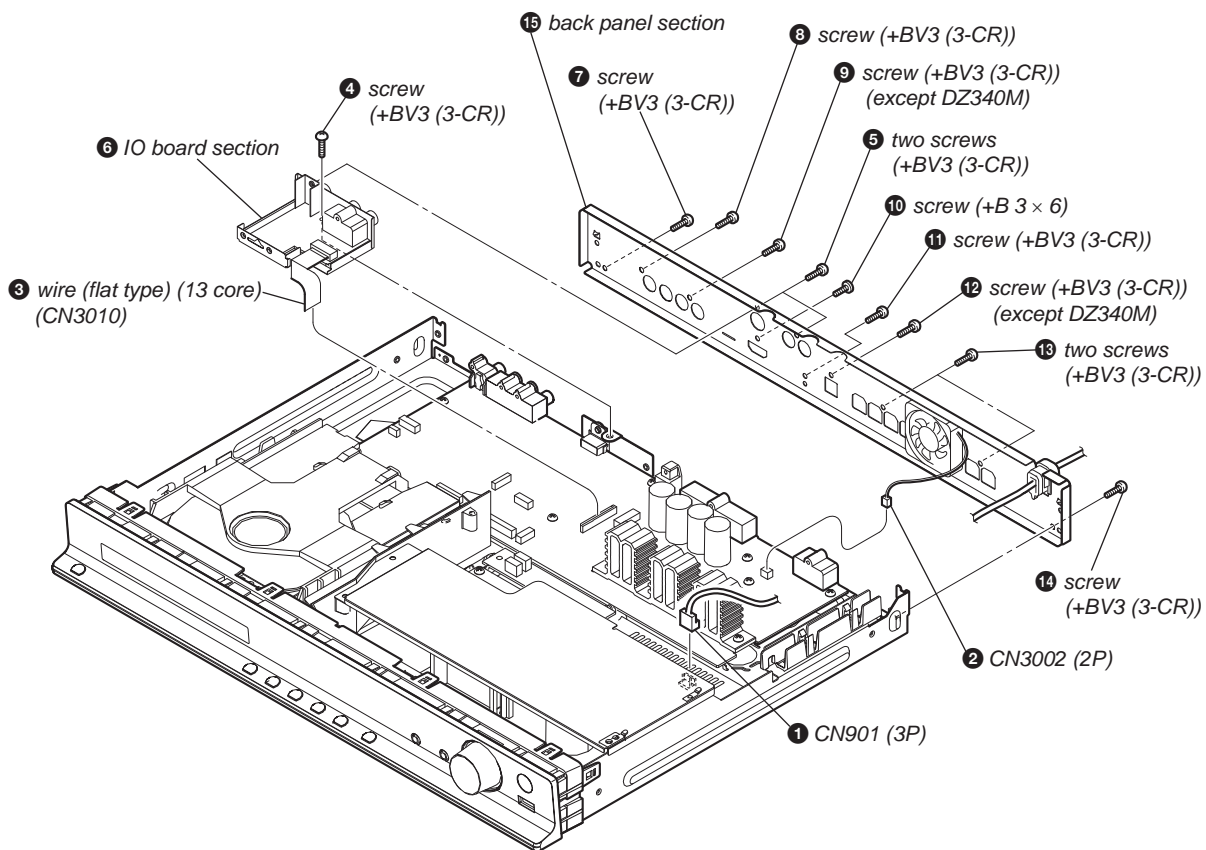

2-8. MAIN BOARD

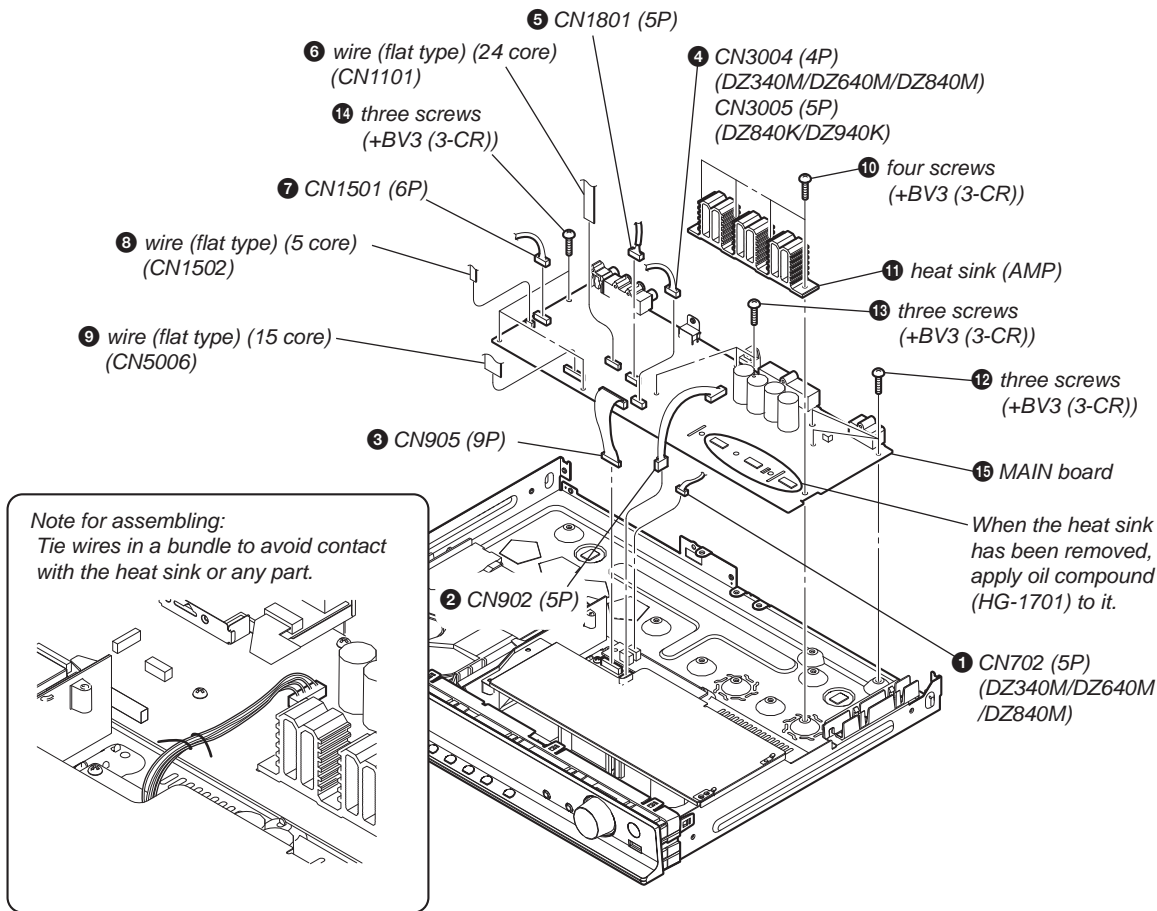

2-9. POWER BOARD

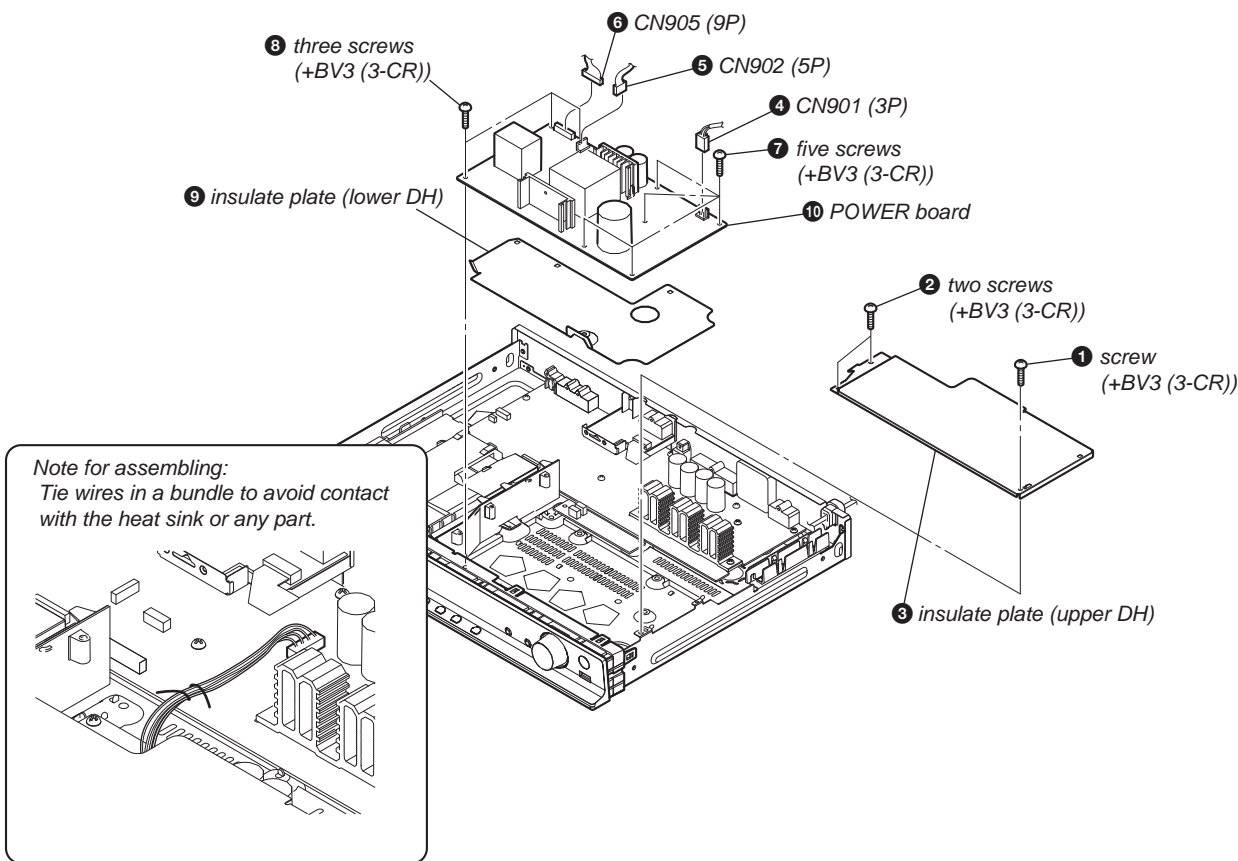

2-10. DVD MECHANISM DECK SECTION

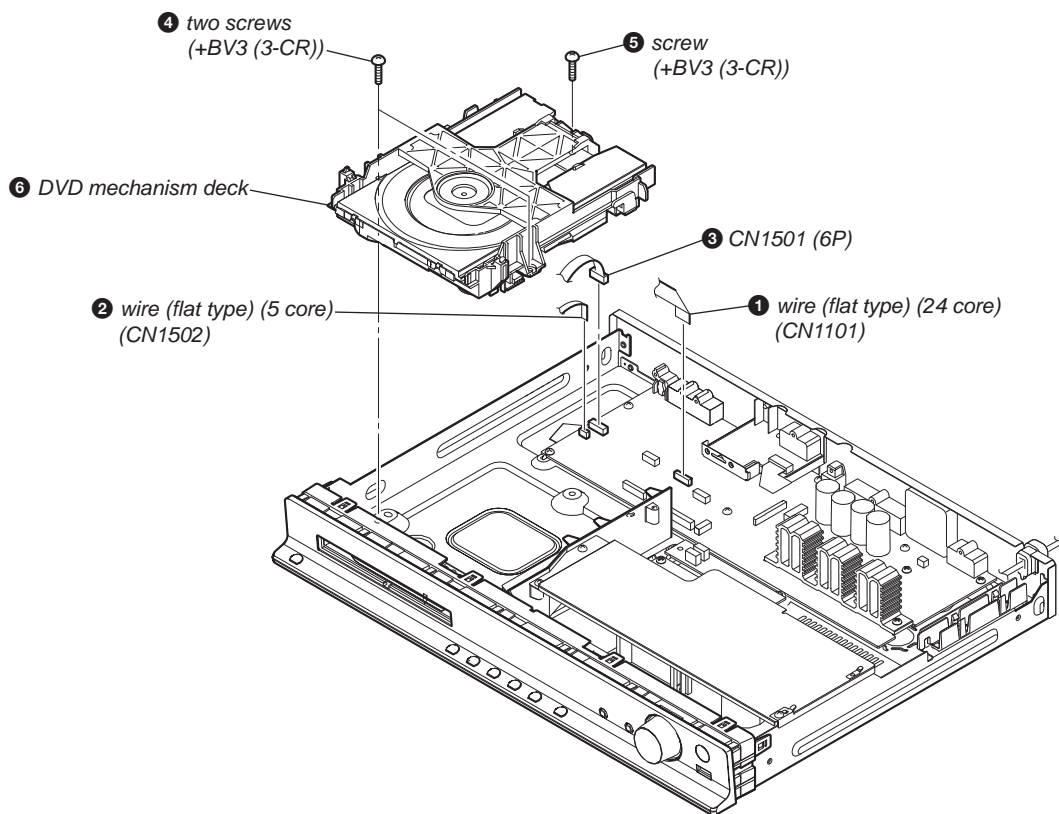

2-11. TRAY

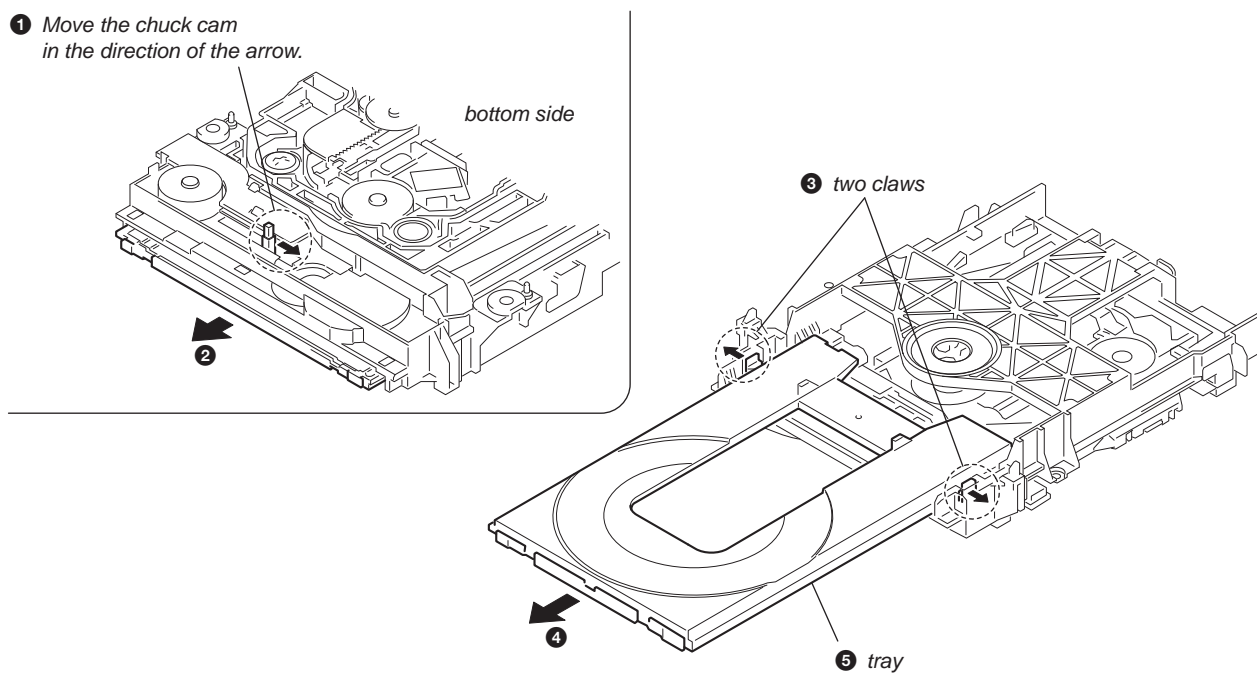

2-12. BELT

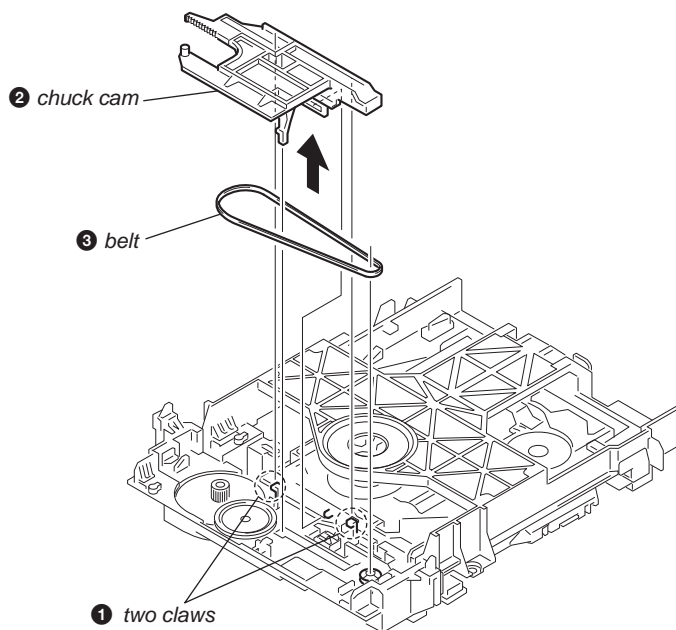

2-13. MS-203 BOARD

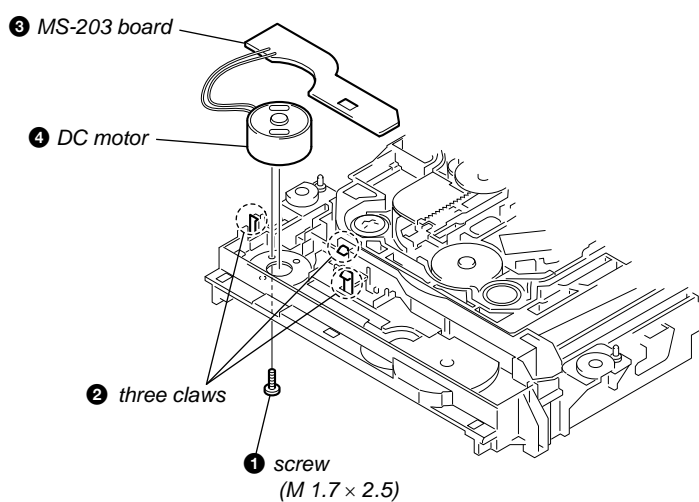

2-14. BASE UNIT

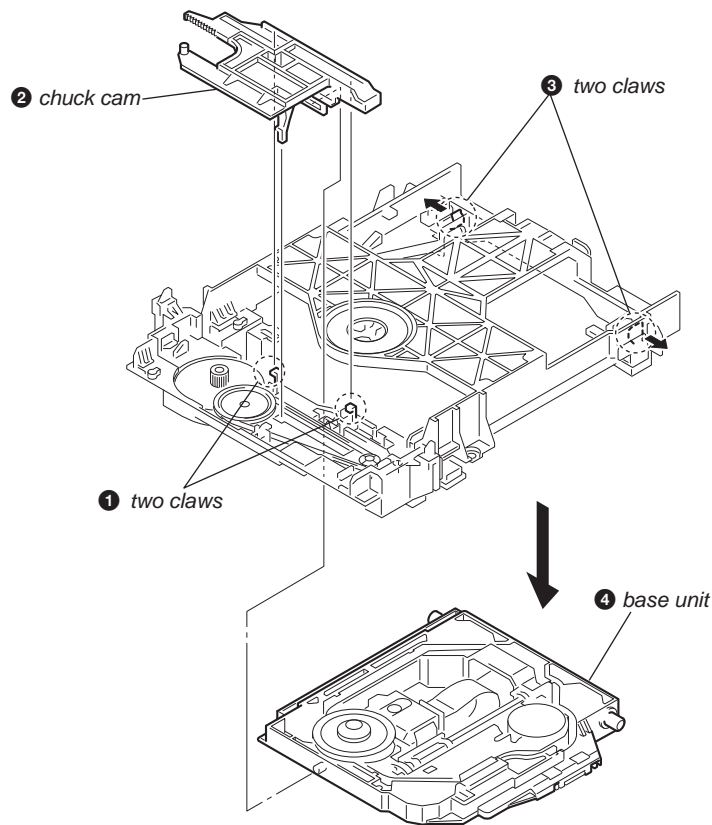

2-15. OPTICAL PICK-UP

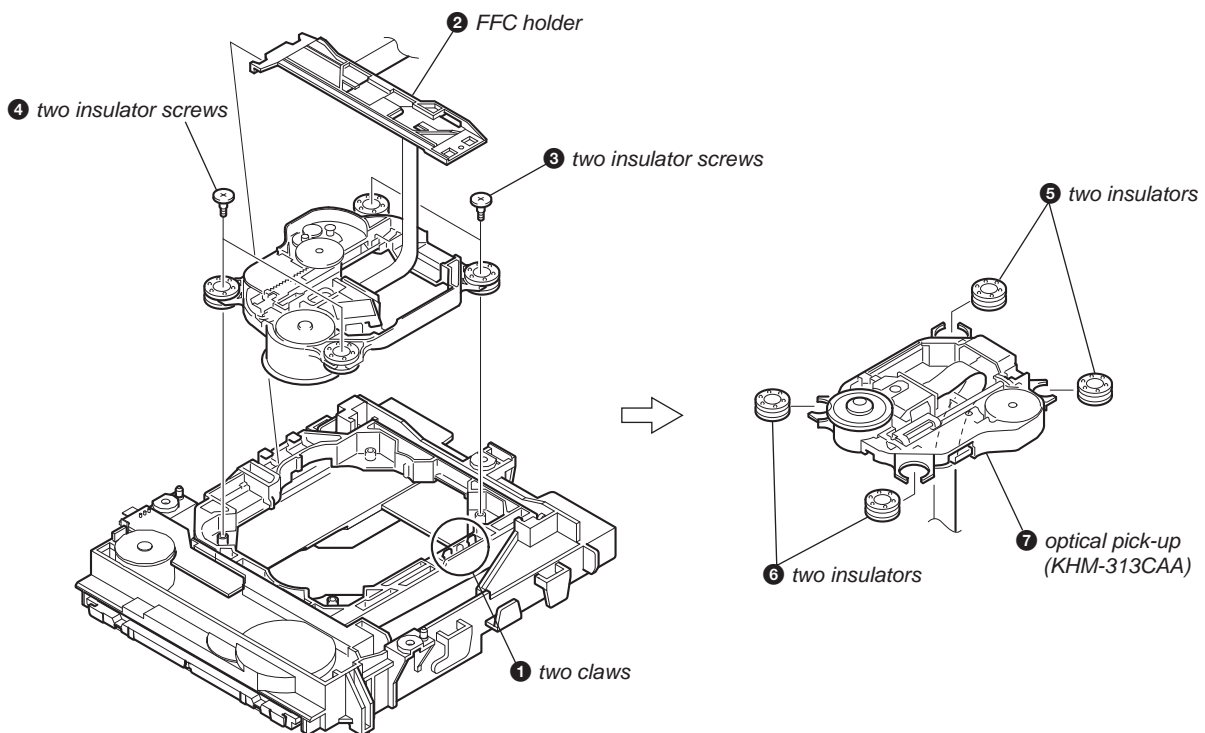

Note: Incorrect operations may be performed if the test mode is not entered properly.
 In this case, press the [I/⏻] button to turn the power off, and retry to enter the test mode.

1. Cold Reset

- The cold reset clears all data including preset data stored in the RAM to initial conditions. Execute this mode when returning the set to the customers.

Procedure:

1. Press the [I/⏻] button to turn the power on.
2. Press three buttons [▶], [FUNCTION] and [I/⏻] simultaneously.
3. When this button is operated, display as “RESET” for a while and all of the settings are reset.

2. Panel Test Mode

- This mode is used to check the software version, FL and KEY.

2-1. Display Test Mode

Procedure:

1. Press the [I/⏻] button to turn the power on.
2. While pressing the [■] and the [▶] buttons simultaneously, turn the [VOLUME] control in the direction of (+).
3. When the display test mode is activated, all segments are turned on. When the mode in, “REC TO USB” and “VOLUME ILLUMINATION” is turn off.
4. To exit from this mode, while pressing the [■] and the [▶] buttons simultaneously, turn the [VOLUME] control in the direction of (+).

2-2. Version Test Mode

Procedure:

1. When the display test mode is activated, press the [FUNCTION] button and the message “DH1M” (DZ340M), “DH4M” (DZ640M), “DH7K” (DZ840K), “DH7M” (DZ840M), “DH8K” (DZ940K) are displayed, the version test mode is activated.
2. Whenever the [FUNCTION] button is pressed, the display changes in the following order.

↳ “DH8” (Model name) → “NA”^{*1} (Destination) → MC Version ↳

*1: NA changes depending on destination.

3. Press the [REC TO USB] button when the MC version is on display. The date of software production is displayed.
4. Press the [REC TO USB] button again and the version is displayed.
5. To exit from this mode, while pressing the [■] and the [▶] buttons simultaneously, turn the [VOLUME] control in the direction of (+).

2-3. FL Pattern Test Mode

Procedure:

1. When the display test mode is activated, press the [▲] button, to select the FL pattern test mode. When the FL pattern test mode, half segments of FL display and “REC TO USB” are turn on.
2. Press the [▲] button, half segments of FL display and “REC TO USB” is turned off.
3. To exit from this mode, while pressing the [■] and the [▶] buttons simultaneously, turn the [VOLUME] control in the direction of (+).

2-4. Key Test Mode

Procedure:

1. When the display test mode is activated, press the [I/⏻] button, to select the key test mode.
2. To enter the KEY test mode, the fluorescent indicator displays “K0 V0”. Each time an another button is pressed, “KEY” value increases. However, once a button is pressed, it is no longer taken into account. When all keys are pressed correctly, “K8 V0” is displayed.
3. When the [VOLUME] control is turned in the direction of (+), “V0” is changed to “V1”, then ... “V9”.
 When the [VOLUME] control is turned in the direction of (-), “V0” is changed to “V9”, then ... “V1”.
4. To exit from this mode, while pressing the [■] and the [▶] buttons simultaneously, turn the [VOLUME] control in the direction of (+).

3. Disc Tray Lock

- The disc tray lock function for the antitheft of an demonstration disc in the store is equipped.

Setting Procedure :

1. Press the [I/⏻] button to turn the set on.
2. Press the [FUNCTION] button to set DVD function.
3. Insert a disc.
4. Press the [■] button and the [▲] button simultaneously for five seconds.
5. The message “LOCKED” is displayed and the tray is locked.

Releasing Procedure :

1. Press the [■] button and the [▲] button simultaneously for five seconds again.
2. The message “UNLOCKED” is displayed and the tray is unlocked.

Note: When “LOCKED” is displayed, the tray lock is not released by turning power on/off with the [I/⏻] button.

4. DVD Version Display

- The STR and DVD microprocessor versions are displayed.

Procedure:

1. Press the [I/⏻] button to turn the set on.
2. Press the [▶] button and the [I/⏻] button simultaneously for three seconds. SC version display is presented.
3. Pressing the [FUNCTION] button presents a DV version display. Pressing the [FUNCTION] button again returns to the SC version display.
4. To exit from this mode, press any button other than the [FUNCTION] button.

5. Product Out

- This mode moves the optical pick-up to the position durable to vibration and clears all data including preset data stored in the STR RAM to initial conditions. Use this mode when returning the set to the customer after repair.

Procedure:

1. Press the [I/⏻] button to turn the power on.
2. Press the [FUNCTION] button to set the function “DVD/CD”.
3. Remove all discs, and then press three buttons [■], [▲] and turn the [VOLUME] control in the direction of (+).
4. Displayed to message “SERVICE” on the fluorescent indicator tube when pressing in turn the [4] → [DVD MENU] → [CLEAR] buttons on the remote commander.
5. After the “STANDBY” blinking display finishes, the message “LOCKED” ⇔ “UNPLUG” is displayed on the fluorescent indicator tube disconnect the AC power plug, then the product out mode is set.
 The STR RAM initialization is executed upon a next power-on after the power is turned off.

6. Color System Change (E3, E12, E15, PH, SP models)

- Color system change to video signal format (NTSC/PAL).

Procedure:

1. Press the [I/⏻] button to turn the set on.
2. Press the [FUNCTION] button to set the function “DVD/CD”.
3. Press the [I/⏻] button to turn the set OFF.
4. Press two buttons [FUNCTION] and [I/⏻] simultaneously, and the display of fluorescent indicator tube changes to “PAL” or “NTSC”.

• Abbreviation

- E3 : 240V AC area in E model
- E12 : 220 – 240V AC area in E model
- E15 : Iranian model
- PH : Philippines model
- SP : Singapore model

7. TUNER TUNED/STEREO Display

- The mode status of TUNED/STEREO is displayed.

1. Press the [I/⏻] button to turn the power on.
2. Press the buttons on the remote commander in the order given below to enter the Test Mode.
[RETURN] → [4] → [0] → [0] → [8] → [ANGLE]
3. The mode status is displayed by the corresponding segment.

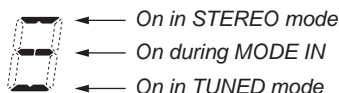

(Indicated by the third segment from the top.)

4. To terminate this mode, perform the operation described in Item 2 or turn the power off.

8. PROTECTION FACTOR (SD DETECTION/ DC DETECTION/TSD DETECTION) IDENTIFICATION TEST MODE

When an error is detected, the FL tube alternately displays “PROTECT” ↔ “PUSH PWR”.

↓ Press the [I/⏻] button.

* Buttons other than the [I/⏻] button are invalid.

“STANDBY” blinks three times on the FL tube.

↓

The protection release state (POWER OFF) is established.

(No FL tube display)

↓ Press the [I/⏻] button two times.

The power to the system turns on, and the normal operation is established. (Restore)

During the protection state:

1. If the AC plug is connected or disconnected during the protection state, the protection state is released, and the normal operation is established. (The protection state is not maintained.)
2. The protection factor is displayed by pressing the [RETURN] → [3] → [2] → [0] → [0] → [ANGLE] buttons of the remote commander.
(during the “PROTECT” ↔ “PUSH PWR” display).
 - ⇒ When SD is detected: Repeats “SD ERR” ↔ “PROTECT”.
 - ⇒ When DC is detected: Repeats “DC ERR” ↔ “PROTECT”.
 - ⇒ When TSD is detected: Repeats “TMP ERR” ↔ “PROTECT”.

PL: SD detection

When the “L” output from the SD (shutdown) port on the S-MASTER POWER Driver Shutdown and voltage descent (15V or less) of 30V power supply (PVDD) are detected.

DC detection

When the “L” output from the power/speaker error detection circuit (DC detection port) is detected for two seconds continually, the power system other than that of the FL tube is turned off, and the protection state is established.

TSD detection

When the “L” output from the thermal shutdown port (TSDM) on the motor driver is detected.

DVD SECTION

9-1. GENERAL DESCRIPTION

- The IOP measurement allows you to make diagnosis and adjustment simply by using the remote commander and monitor TV. The instructions, diagnosis results, etc. are given on the on-screen display (OSD).
Be sure to execute the IOP measurement when a BU (Base Unit) is replaced.

9-2. HOW TO ENTER TEST MODE

While pressing the [■] and the [▲] buttons simultaneously, turn the [VOLUME] control in the direction of (+) with the DVD player in power on.

The Test Mode starts, displayed "SERVICE" on this model display then the menu shown below will be displayed on the TV screen.

* The display of the "Model Name" of the "Remocon Diagnosis Menu" change with the model and the destination. Refer to below on the model name.

- DZ340M : DH1M
- DZ640M : DH4M
- DZ840K : DH7K
- DZ840M : DH7M
- DZ940M : DH8K

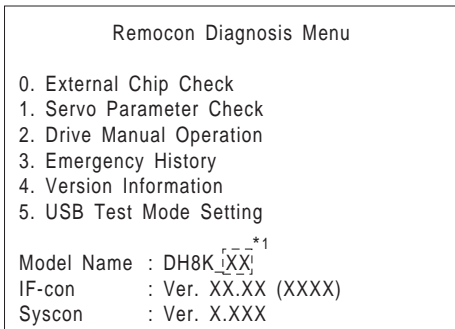

*1: Changes depending on destination

The menu above is the Remocon Diagnosis Menu screen which consists of five main functions. At the bottom of the menu screen, the model name and IF-con version. To exit from the Test Mode, press the [I/⏻] button on the remote commander.

9-3. EXECUTING IOP MEASUREMENT

In order to execute IOP measurement, the following standard procedures must be followed.

- (1) In power on, while pressing the [■] and the [▲] buttons simultaneously, turn the [VOLUME] control in the direction of (+).

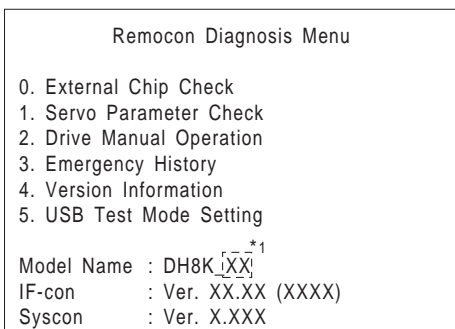

*1: Changes depending on destination

- (2) Select "2. Drive Manual Operation" by pressing the [2] button on the remote commander. The screen will appear as shown.

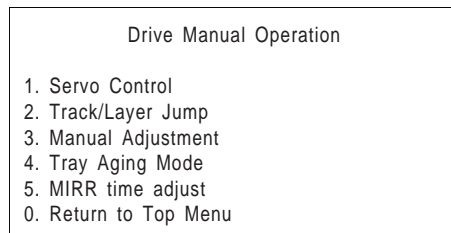

- (3) Select "3. Manual Adjustment" by pressing the [3] button on the remote commander. The screen will appear as shown.

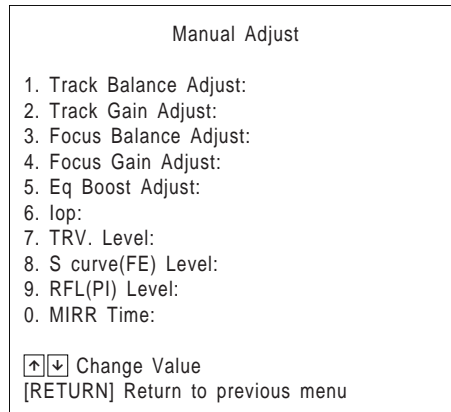

- (4) Select "6. IOP" by pressing the [6] button on the remote commander.

- (5) Wait until a hexadecimal number appear.

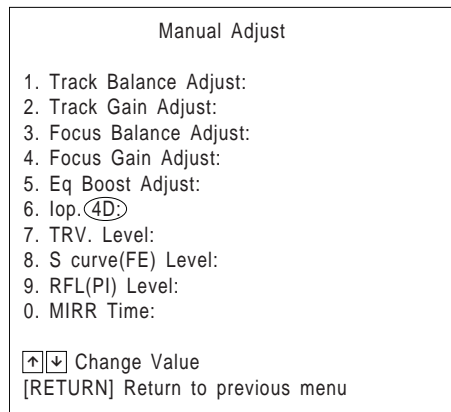

- (6) Convert each data from hexadecimal to decimal using conversion table.

- (7) Please find the label on the rear of the BU (Base Unit). The default IOP value is written in the label.

- (8) Subtract between these two values.

- (9) If the remainder is smaller than 93 (decimal), then it is OK. However if the value is higher than 93, then the BU is defective and need to be change.

- (10) Press the [RETURN] button on the remote commander to return back to previous menu.

- (11) Press the [0] button on the remote commander to return to Top Menu.

9-4. EMERGENCY HISTORY

To check the emergency history, please follow the following procedure.

- (1) From the Top Menu of Remocon Diagnosis Menu, select "3. Emergency History Check" by pressing the [3] button on the remote commander. The following screen appears on the on-screen display.

Emg. History Check													
Laser Hours		CD		999h		59min		DVD		999h		59min	
01.	01	05	04	04	00	92	46	00	00	00	00	23	45
02.	02	02	01	01	00	A9	4B	00	00	00	00	23	45
[Next] Next Page		[Prev] Prev Page											
[0] Return to Top Menu													

- (2) You can check the total time when the laser is turned on during playback of DVD and CD from the above menu. The maximum time, which can be displayed are 999h 59min.
- (3) You can check the error code of latest 10 emergency history from the above menu. To view the previous or next page of emergency history, press [◀] or [▶] button on the remote commander. The error code consists of the following three blocks. The first block indicates the error code. The second block indicates the parameter and the third block indicates the time of error code as shown below.

• Error Code

Emg. History Check													
Laser Hours		CD		999h		59min		DVD		999h		59min	
01.	^{*1} 01	^{*2} 05	04	04	00	92	46	00	00	00	00	23	45 ^{*3}
02.	02	02	01	01	00	A9	4B	00	00	00	00	23	45
[Next] Next Page		[Prev] Prev Page											
[0] Return to Top Menu													

- *1 : Error Code
- *2 : Parameter of error code
- *3 : Time of error code

- The meaning of error code is as below:
- 01: Communication error (No reply from syscon)
 - 02: Syscon hung up
 - 03: Power OFF request when syscon hung up
 - 19: Thermal shutdown
 - 24: MoveSledHome error
 - 25: Mechanical move error (5 Changer)
 - 26: Mechanical move stack error
 - 30: DC motor adjustment error
 - 31: DPD offset adjustment error
 - 32: TE balance adjustment error
 - 33: TE sensor adjustment error
 - 34: TE loop gain adjustment error
 - 35: FE loop gain adjustment error
 - 36: Bad jitter after adjustment
 - 40: Focus NG
 - 42: Focus layer jump NG
 - 51: Spindle stop error
 - 52: Open kick spindle error

- 60: Focus on error
- 61: Seek fail error
- 62: Read Q data/ID error
- 70: Lead in data read fail
- 71: TOC read time out (CD)
- 80: Can't buffering
- 81: Unknown media type

9-4-1. Clear the Laser Hour

Press [DISPLAY] button and then press [CLEAR] button on the remote commander. The data for both CD and DVD data are reset.

Emg. History Check													
Laser Hours		CD		0h		0min		DVD		0h		0min	
01.	01	05	04	04	00	92	46	00	00	00	00	23	45
02.	02	02	01	01	00	A9	4B	00	00	00	00	23	45
[Next] Next Page		[Prev] Prev Page											
[0] Return to Top Menu													

9-4-2. Clear the Emergency History

Press [DVD TOP MENU] button and then press [CLEAR] button on the remote commander. The error code for all emergency history would be reset.

Emg. History Check													
Laser Hours		CD		999h		59min		DVD		999h		59min	
01.	00	00	00	00	00	00	00	00	00	00	00	00	00
02.	00	00	00	00	00	00	00	00	00	00	00	00	00
[Next] Next Page		[Prev] Prev Page											
[0] Return to Top Menu													

9-4-3. Clear the Initialize Setup Data

Press [DVD MENU] button and then press [CLEAR] button on the remote commander.

Emg. History Check													
Laser Hours		CD		999h		59min		DVD		999h		59min	
initialize setup data...													
[Next] Next Page		[Prev] Prev Page											
[0] Return to Top Menu													

9-4-4. Return to the Top Menu of Remocon Diagnosis Menu

Press [0] button on the remote commander.

SECTION 4 ELECTRICAL ADJUSTMENTS

9-5. CHECK VERSION INFORMATION

To check the version information, please follow the following procedure.

- (1) From the Top Menu of Remocon Diagnosis Menu, select "4. Version Information" by pressing the [4] button on the remote commander. The following screen appears on the on-screen display.

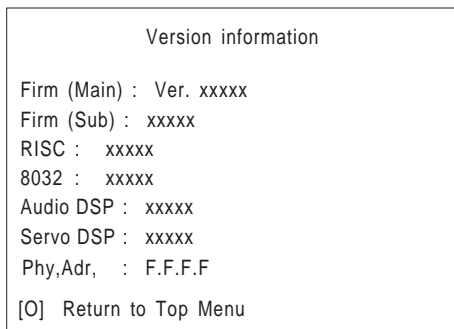

To return to the Top Menu of Remocon Diagnosis Menu, press [0] button on the remote commander.

DVD SECTION

When the optical pick-up assy is replaced, perform the "EXECUTING IOP MEASUREMENT".

EXECUTING IOP MEASUREMENT (See page 19)

TUNER SECTION

[FM Tune Level Check]

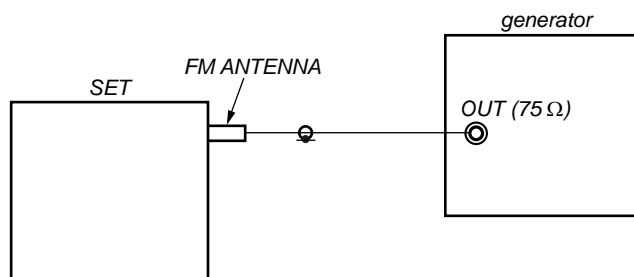

Procedure:

1. Turn the power on.
2. Input the following signal from Signal Generator to FM antenna input directly.

* Carrier Freq : A = 87.5 MHz, B = 98 MHz, C = 108 MHz
 Deviation : 75 kHz
 Modulation : 1 kHz
 ANT input : 35 dBu (EMF)

Note: Please use 75 ohm "coaxial cable" to connect SG and the set. You cannot use video cable for checking.
 Please use SG whose output impedance is 75 ohm.

3. Set to FM tuner function and tune A, B and C signals.
4. Confirm "TUNED" mark is lit on the display for A, B and C signals.

The mark of "TUNED" mark means "The selected station signal is received in good condition."

Note: The "TUNED" mark is displayed by the upper, middle, and lower segments.

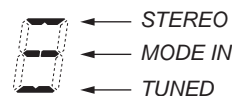

SECTION 5
DIAGRAMS

THIS NOTE IS COMMON FOR PRINTED WIRING BOARDS AND SCHEMATIC DIAGRAMS.
(In addition to this, the necessary note is printed in each block.)

For Printed Wiring Boards.

Note:

- : Parts extracted from the component side.
- : Through hole.
- : Pattern from the side which enables seeing.
(The other layers' patterns are not indicated.)

Caution:

Pattern face side: Parts on the pattern face side seen from the pattern face are indicated.
(SIDE B)
Parts face side: Parts on the parts face side seen from the parts face are indicated.
(SIDE A)

- Indication of transistor.

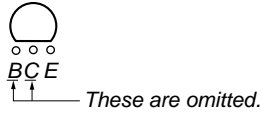
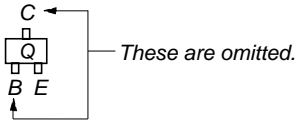

- Abbreviation

- E3 : 240V AC area in E model
- E12 : 220 – 240V AC area in E model
- E15 : Iranian model
- EA : Saudi Arabia model
- PH : Philippines model
- RU : Russian model
- SP : Singapore model
- TH : Thai model

For Schematic Diagrams.

Note:

- All capacitors are in μF unless otherwise noted. (p: pF) 50 WV or less are not indicated except for electrolytics and tantalums.
- All resistors are in Ω and 1/4 W or less unless otherwise specified.
- \triangle : Internal component.
- : Panel designation.

Note: The components identified by mark \triangle or dotted line with mark \triangle are critical for safety.
Replace only with part number specified.

- : B+ Line.
- - - : B- Line.
- Voltages and waveforms are dc with respect to ground under no-signal (detuned) conditions.
- Voltages and waveforms are dc with respect to ground in service mode.
- Waveforms are taken with a oscilloscope.
Voltage variations may be noted due to normal production tolerances.
- no mark: TUNER (FM)
- < >: DVD PLAY
- * : Impossible to measure
- Voltages are taken with VOM (Input impedance 10 M Ω).
- Circled numbers refer to waveforms.
- Signal path.
 - ⇒ : TUNER
 - ⇒ : DVD PLAY
 - ⇒ : VIDEO
 - ⇒ : COMPONENT VIDEO
 - △ : MIC
 - : AUDIO IN
- Abbreviation
 - E3 : 240V AC area in E model
 - E12 : 220 – 240V AC area in E model
 - E15 : Iranian model
 - EA : Saudi Arabia model
 - PH : Philippines model
 - RU : Russian model
 - SP : Singapore model
 - TH : Thai model

- Circuit Boards Location

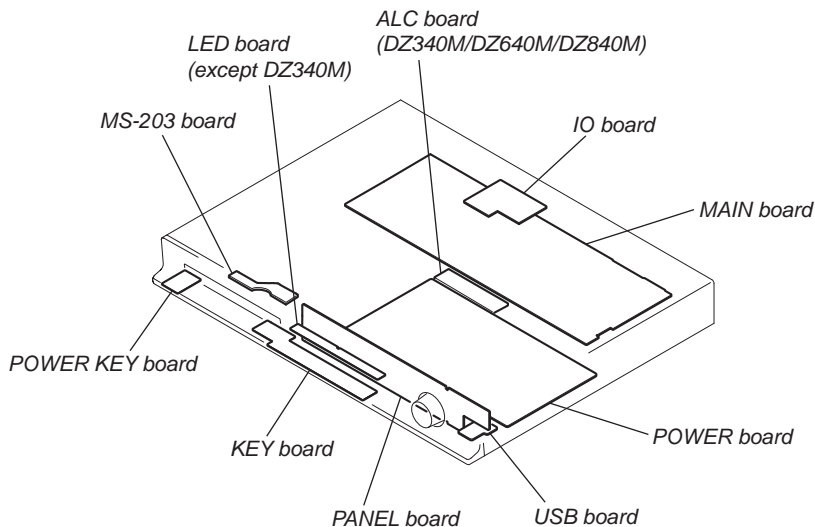

5-1. BLOCK DIAGRAM – RF Section –

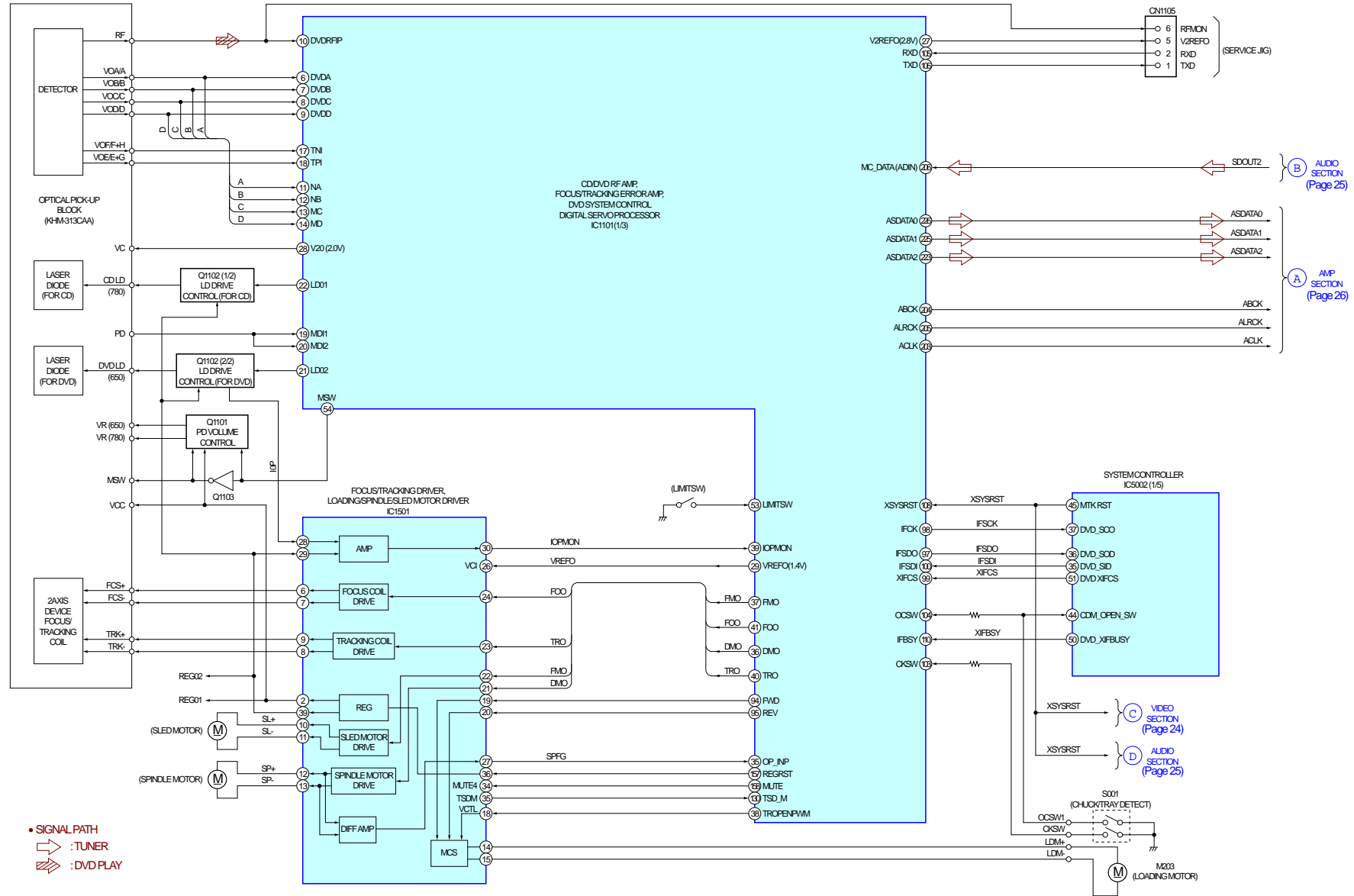

5-2. BLOCK DIAGRAM – VIDEO Section –

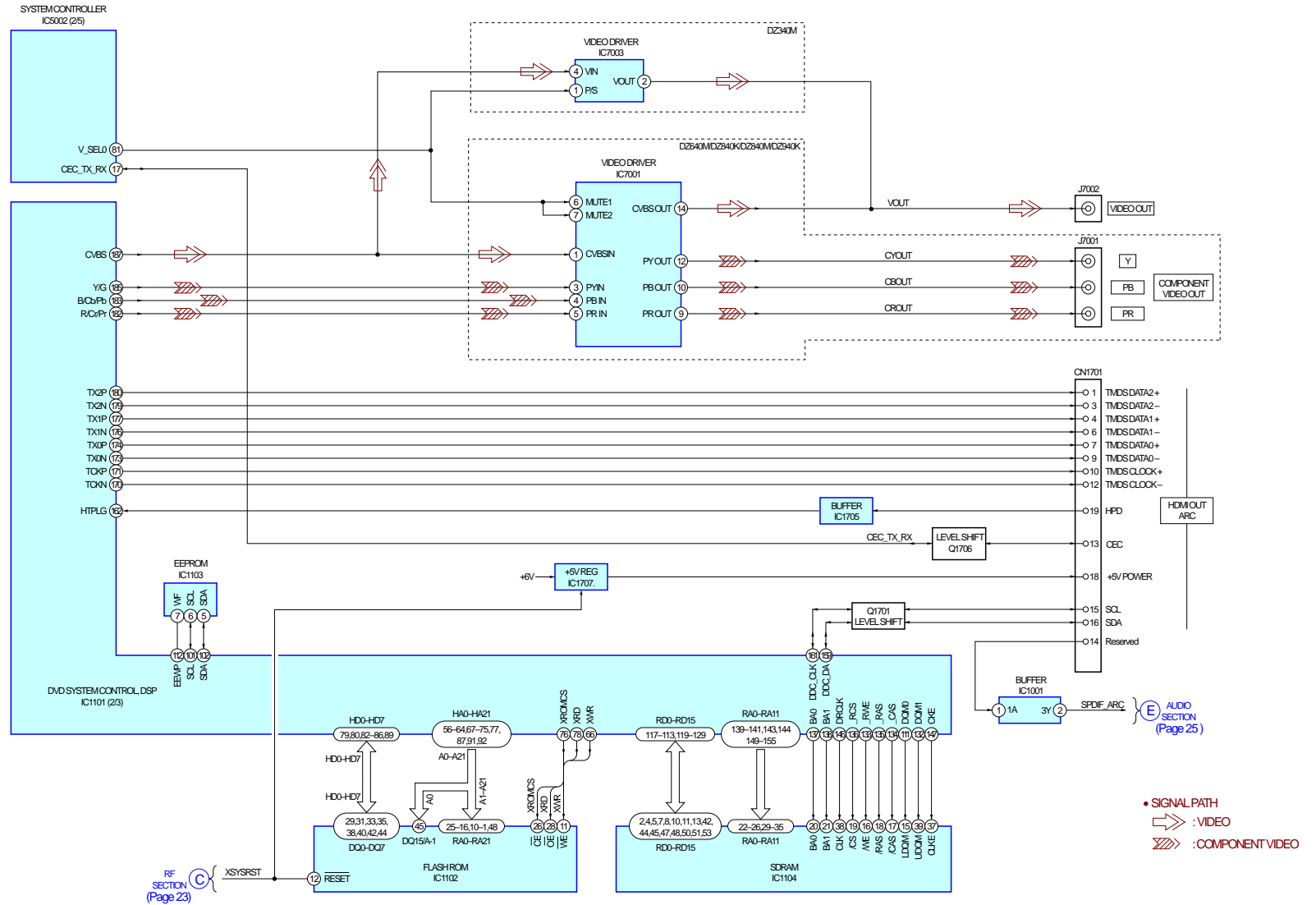

5-3. BLOCK DIAGRAM – AUDIO Section –

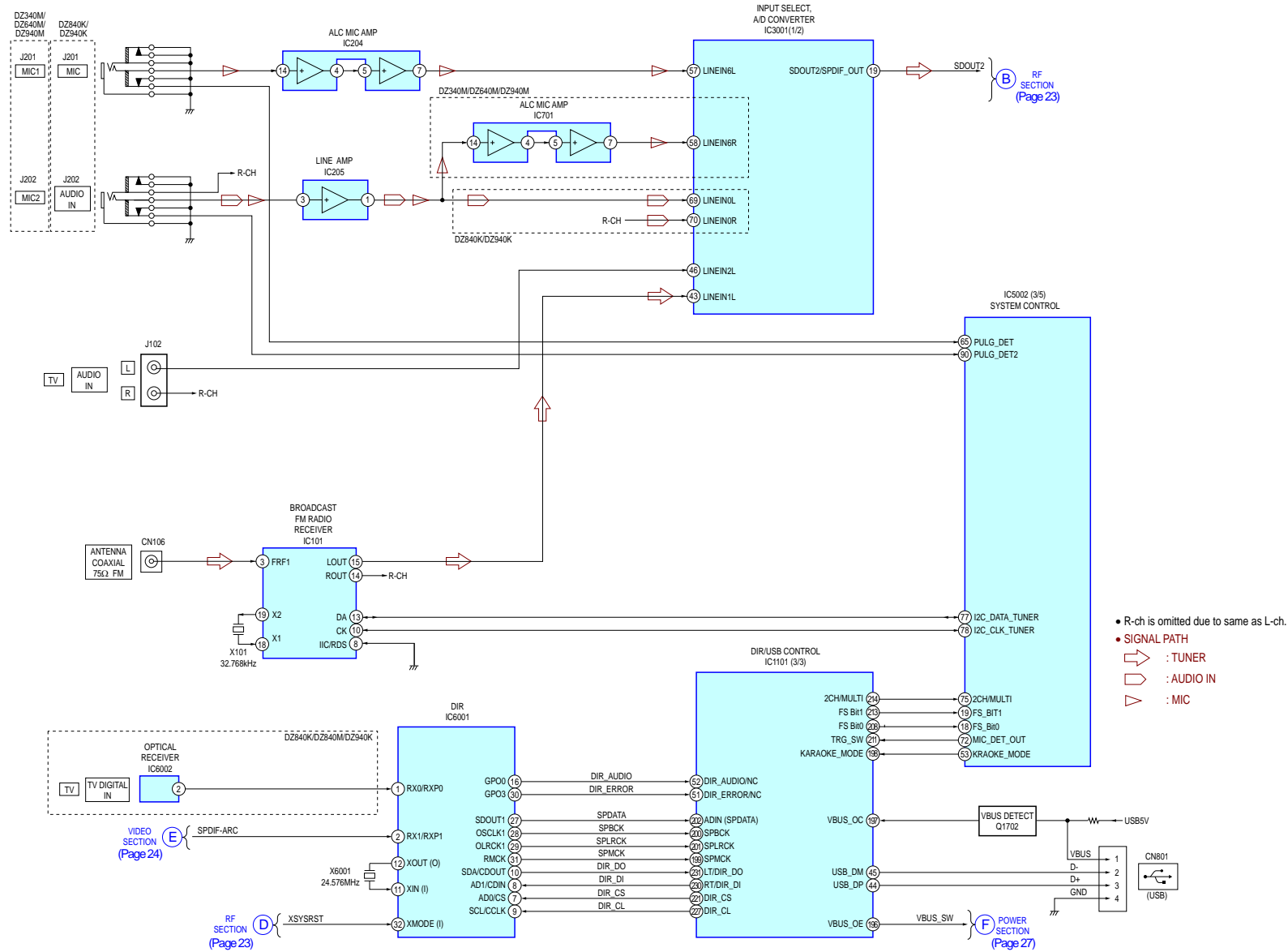

5-4. BLOCK DIAGRAM – AMP Section –

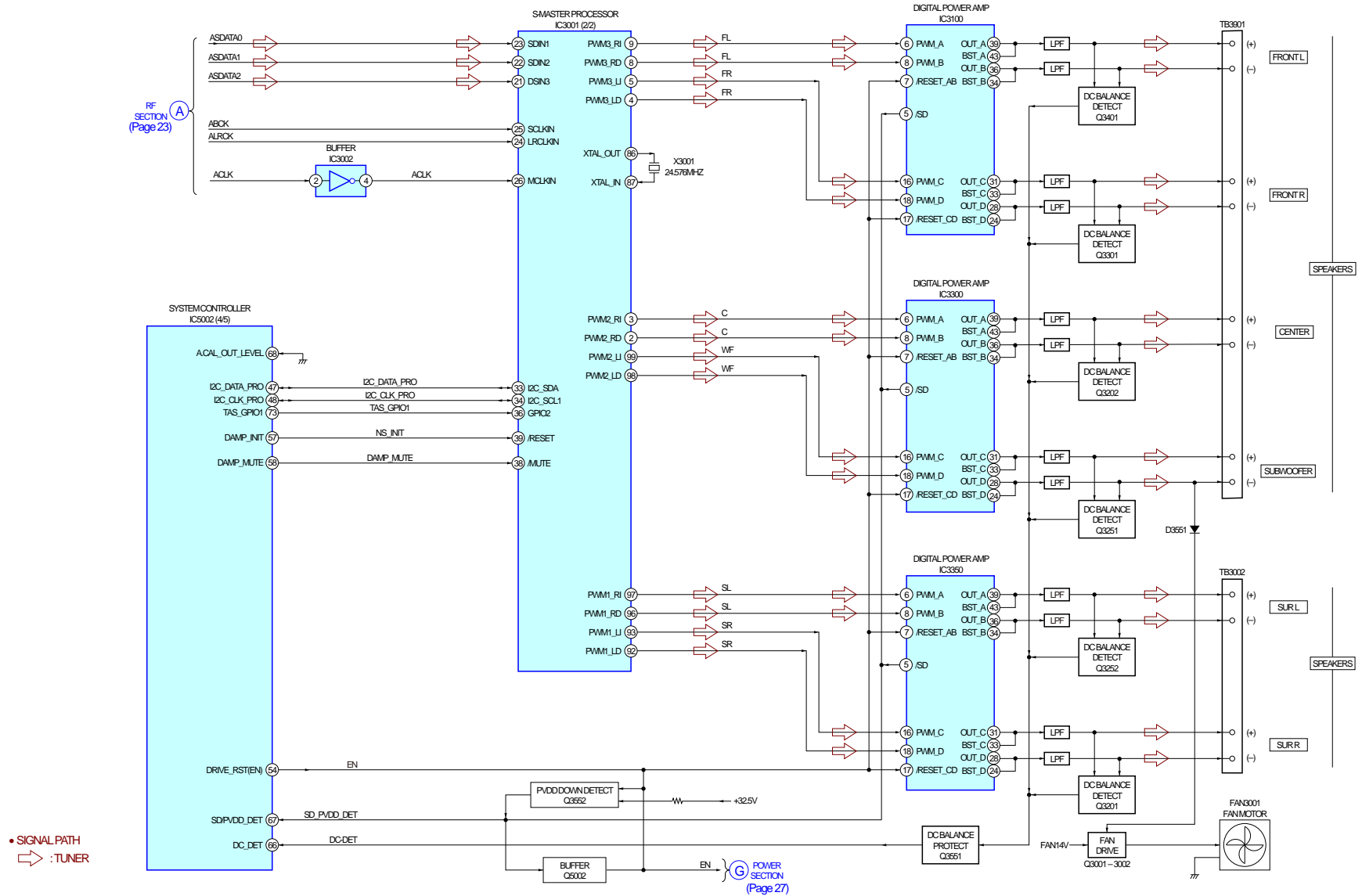

5-5. BLOCK DIAGRAM – POWER Section –

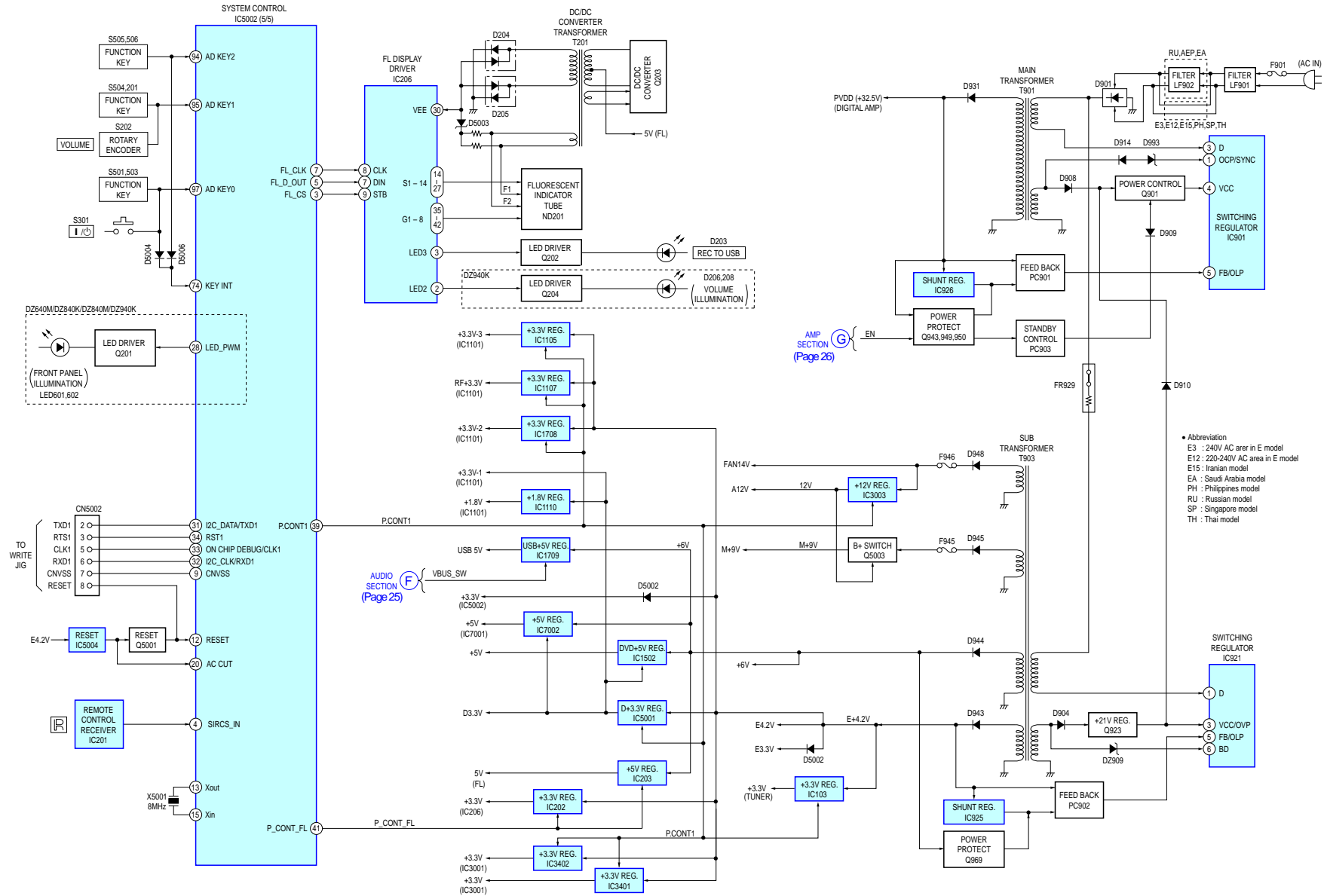

• Abbreviation
 E3 : 240V AC arer in E model
 E12 : 220-240V AC area in E model
 E15 : Iranian model
 EA : Saudi Arabia model
 PH : Philippines model
 RU : Russian model
 SP : Singapore model
 TH : Thai model

• Waveforms

– MAIN Board –

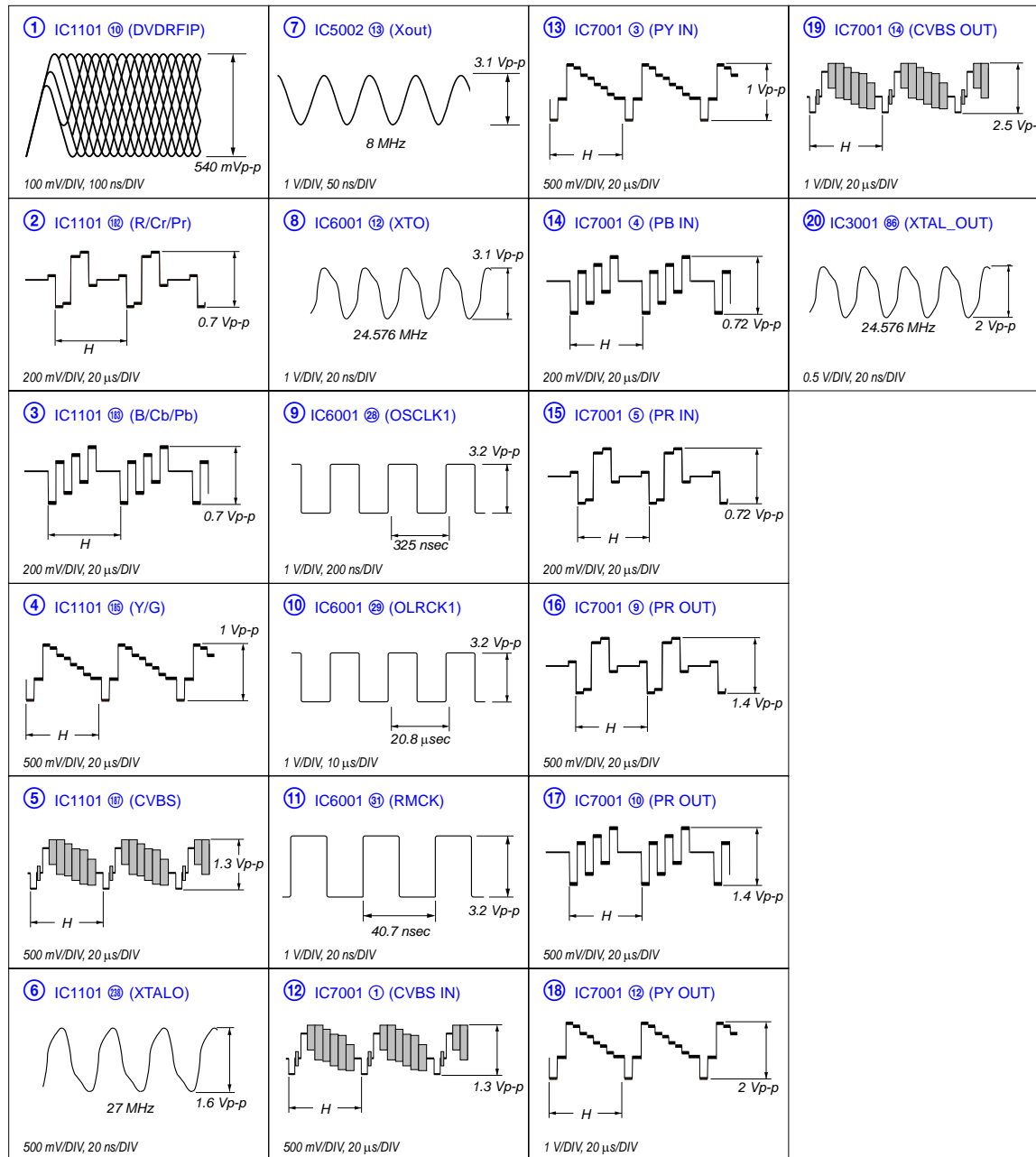

– IO Board –

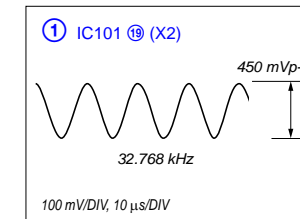

5-6. PRINTED WIRING BOARD – MAIN Section (1/2) – • See page 22 for Circuit Boards Location. •  : Uses unleaded solder.

Note: When IC1501, IC5004 and IC6001 on the Main board are damaged, exchange the new Main board for the Main board which IC damaged.

14 | 13 | 12 | 11 | 10 | 9 | 8 | 7 | 6 | 5 | 4 | 3 | 2 | 1

A
B
C
D
E
F
G
H

【MAIN BOARD】(SIDE A)

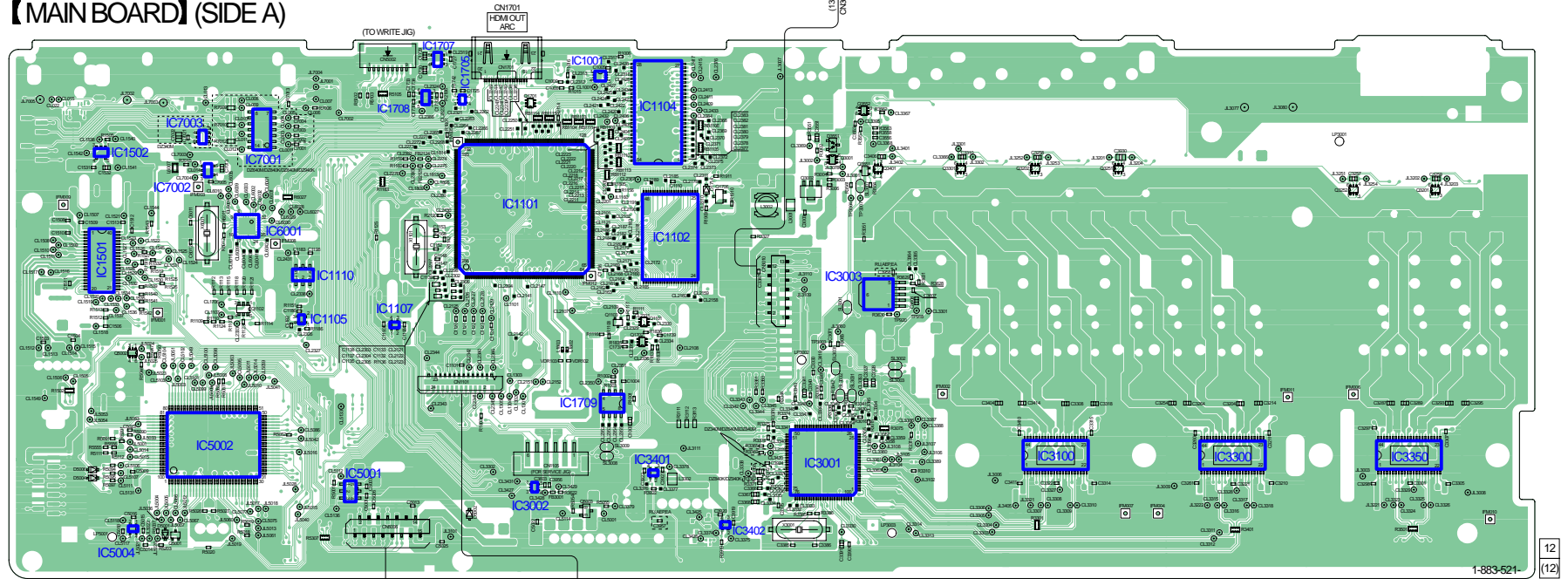

(Page 40)
IC BOARD CN103
L

(Page 46)
PANEL BOARD CN201
G

DVD DRIVE (1/2) (OPTICAL PICK-UP) (KHM-313CAA)

12 (12)

Note: When IC1103 on the Main board is damaged, exchange the new Main board for the Main board which IC damaged.

5-7. PRINTED WIRING BOARD – MAIN Section (2/2) – • See page 22 for Circuit Boards Location. •  : Uses unleaded solder.

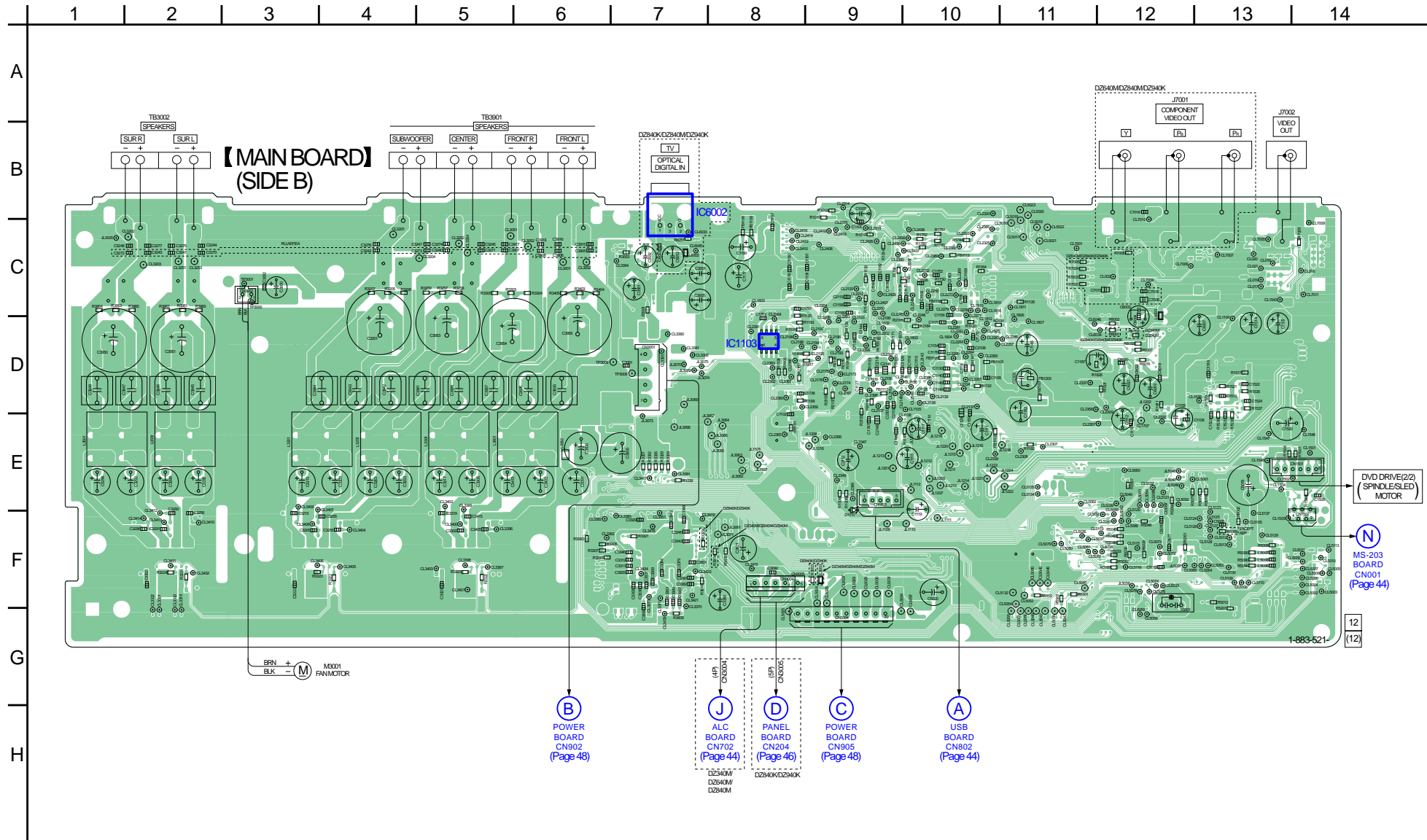

Note: When IC1103 on the Main board is damaged, exchange the new Main board for the Main board which IC damaged.

5-8. SCHEMATIC DIAGRAM – MAIN Section (1/9) –

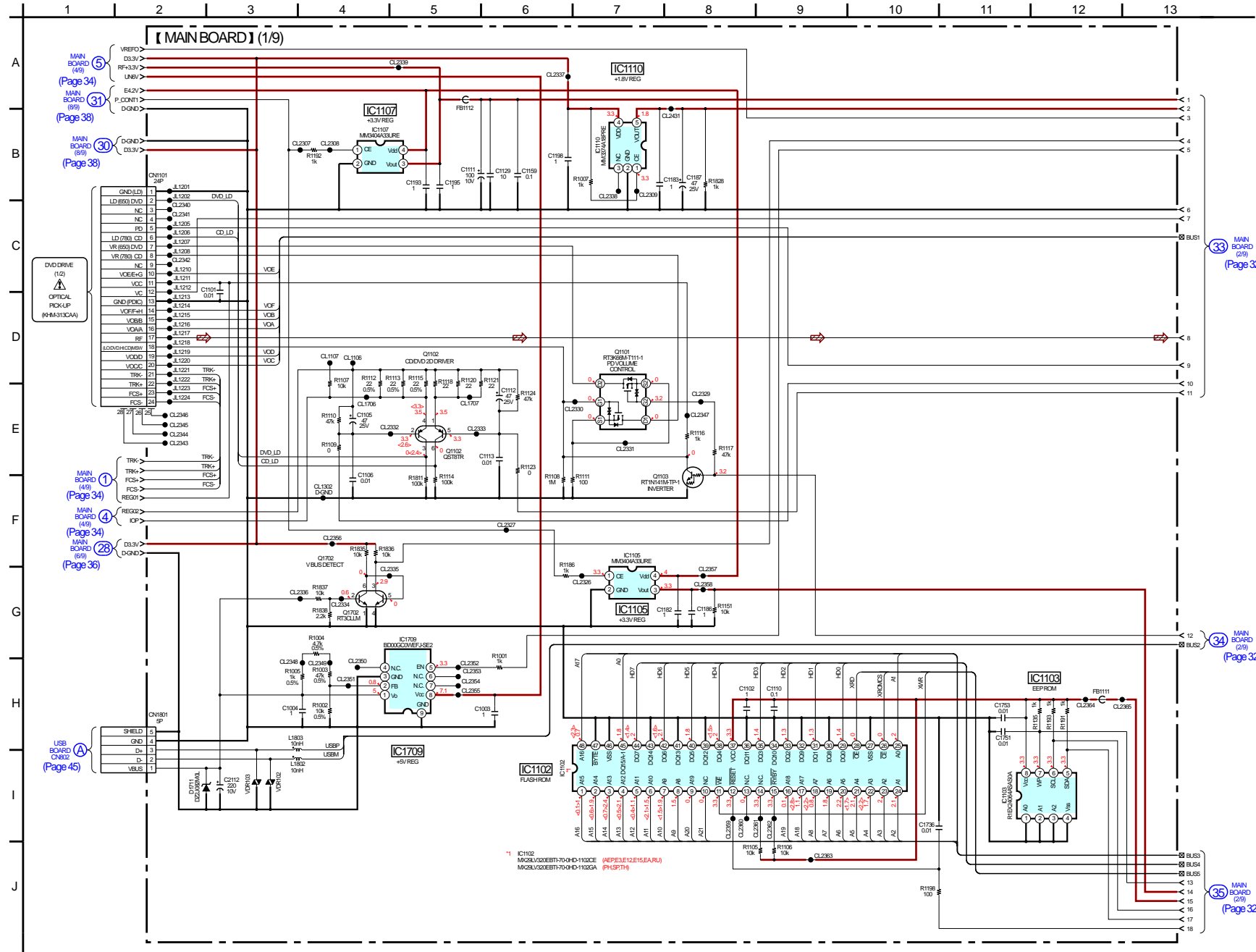

5-9. SCHEMATIC DIAGRAM – MAIN Section (2/9) – • See page 28 for waveforms. • See page 54 for IC Pin Function Description of IC1101.

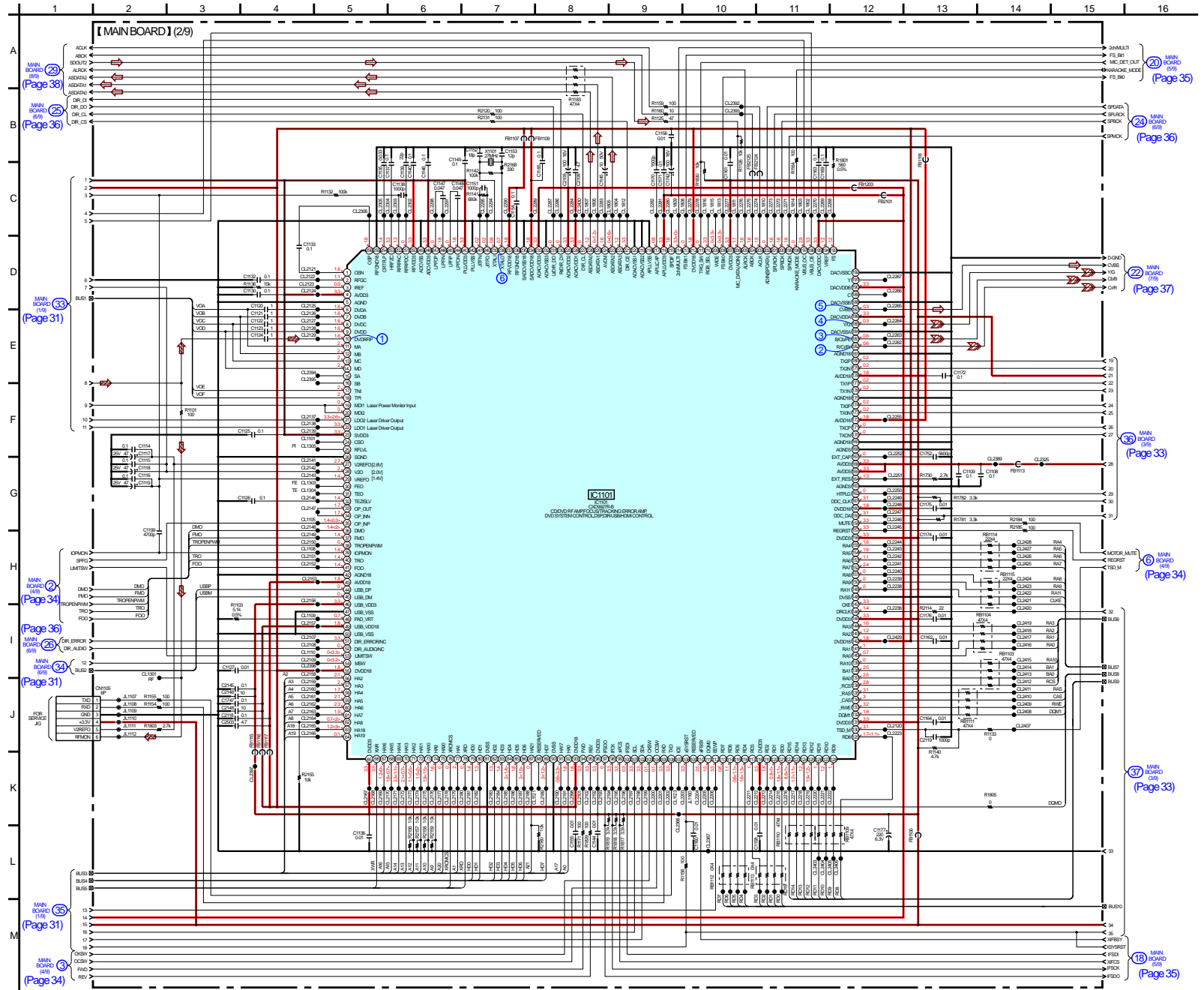

5-10. SCHEMATIC DIAGRAM – MAIN Section (3/9) – • See page 50 for IC Block Diagrams.

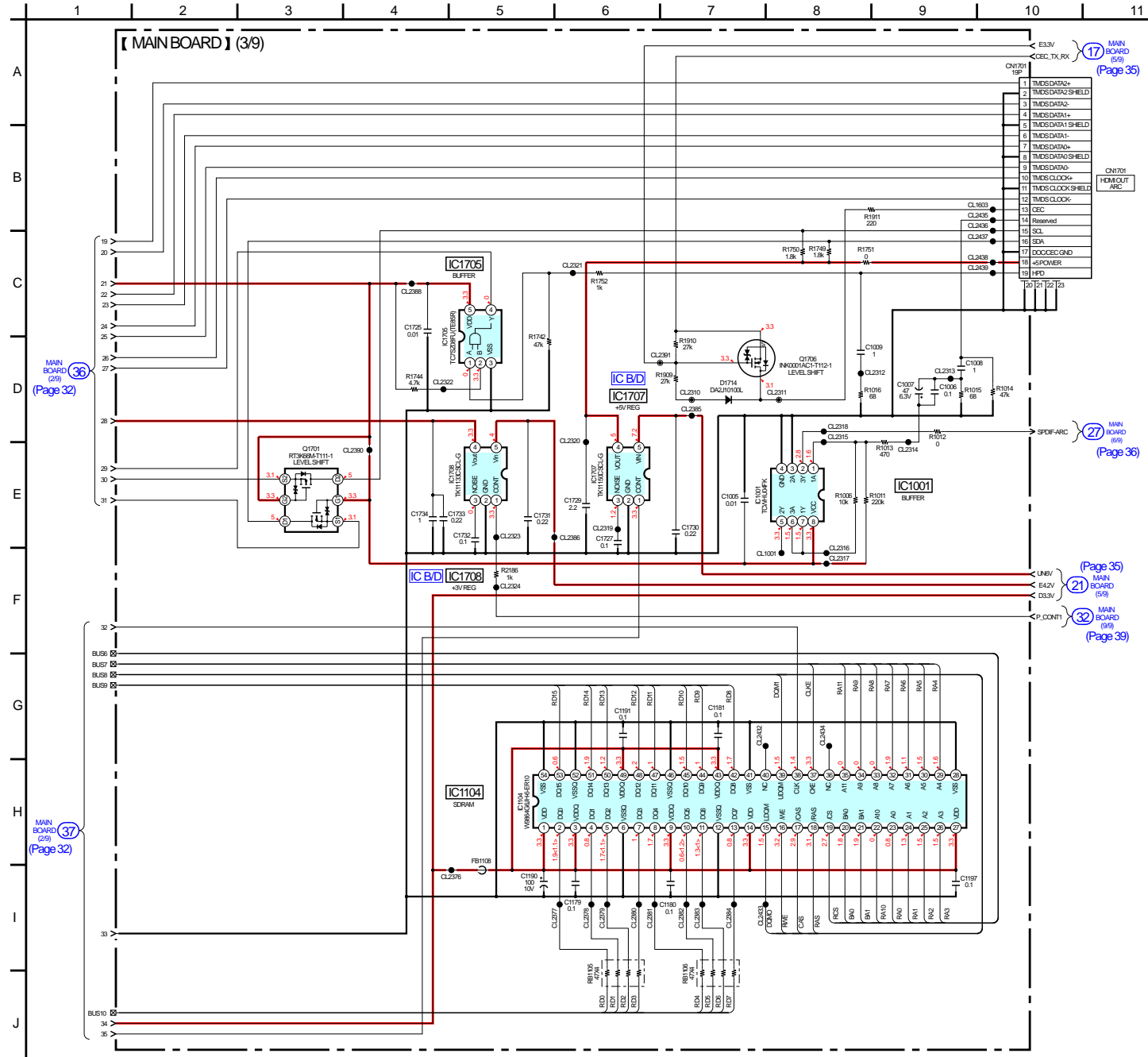

MAIN BOARD (29) (Page 32)

MAIN BOARD (59) (Page 35)

MAIN BOARD (69) (Page 36)

MAIN BOARD (59) (Page 35)

MAIN BOARD (59) (Page 39)

MAIN BOARD (29) (Page 32)

5-11. SCHEMATIC DIAGRAM – MAIN Section (4/9) – • See page 50 for IC Block Diagram.

Note: When IC1501 on the Main board is damaged, exchange the new Main board for the Main board which IC damaged.

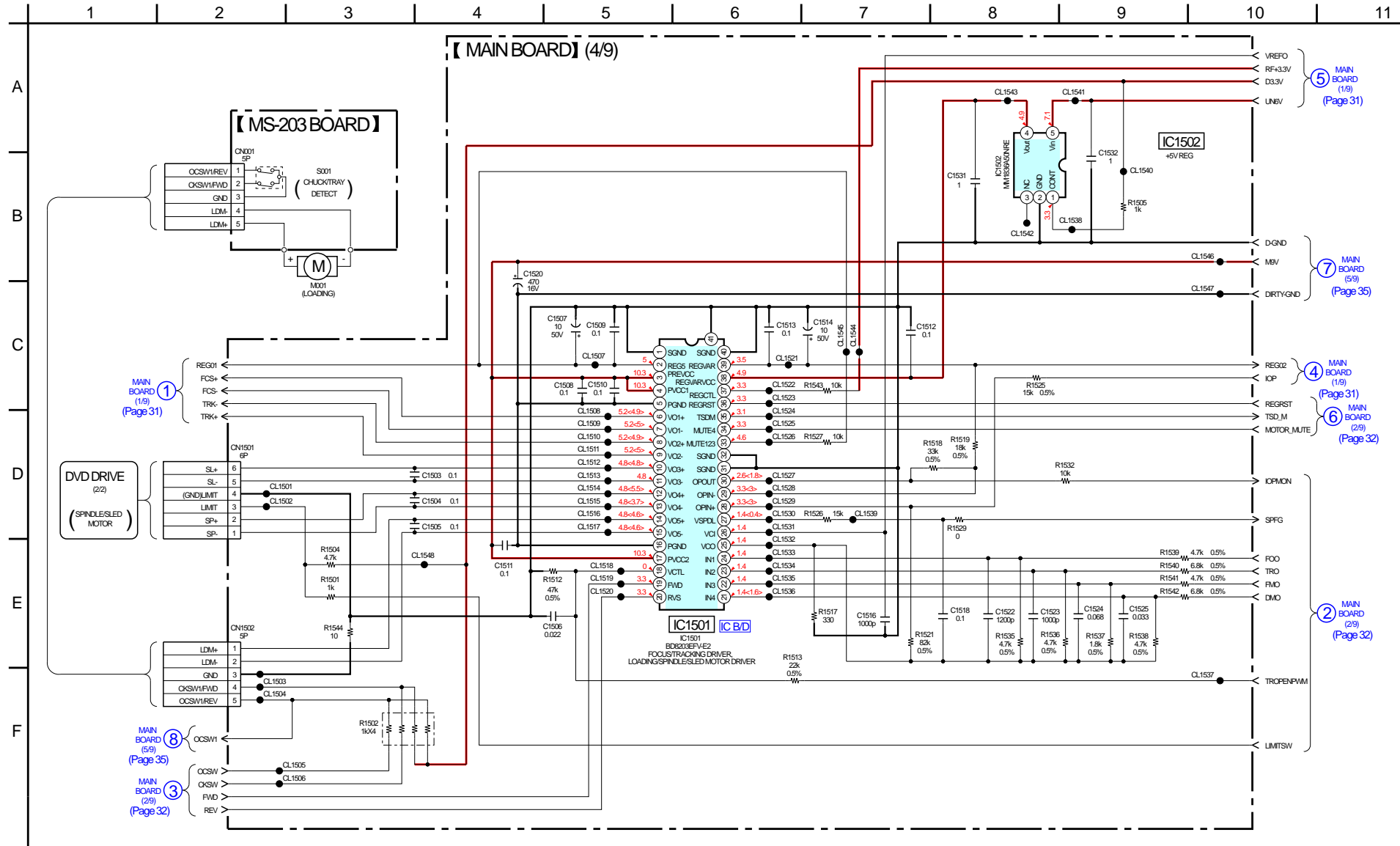

Note: When IC5004 on the Main board is damaged, exchange the new Main board for the Main board which IC damaged.

5-12. SCHEMATIC DIAGRAM – MAIN Section (5/9) – See page 28 for waveform. See page 58 for IC Pin Function Description of IC5002.

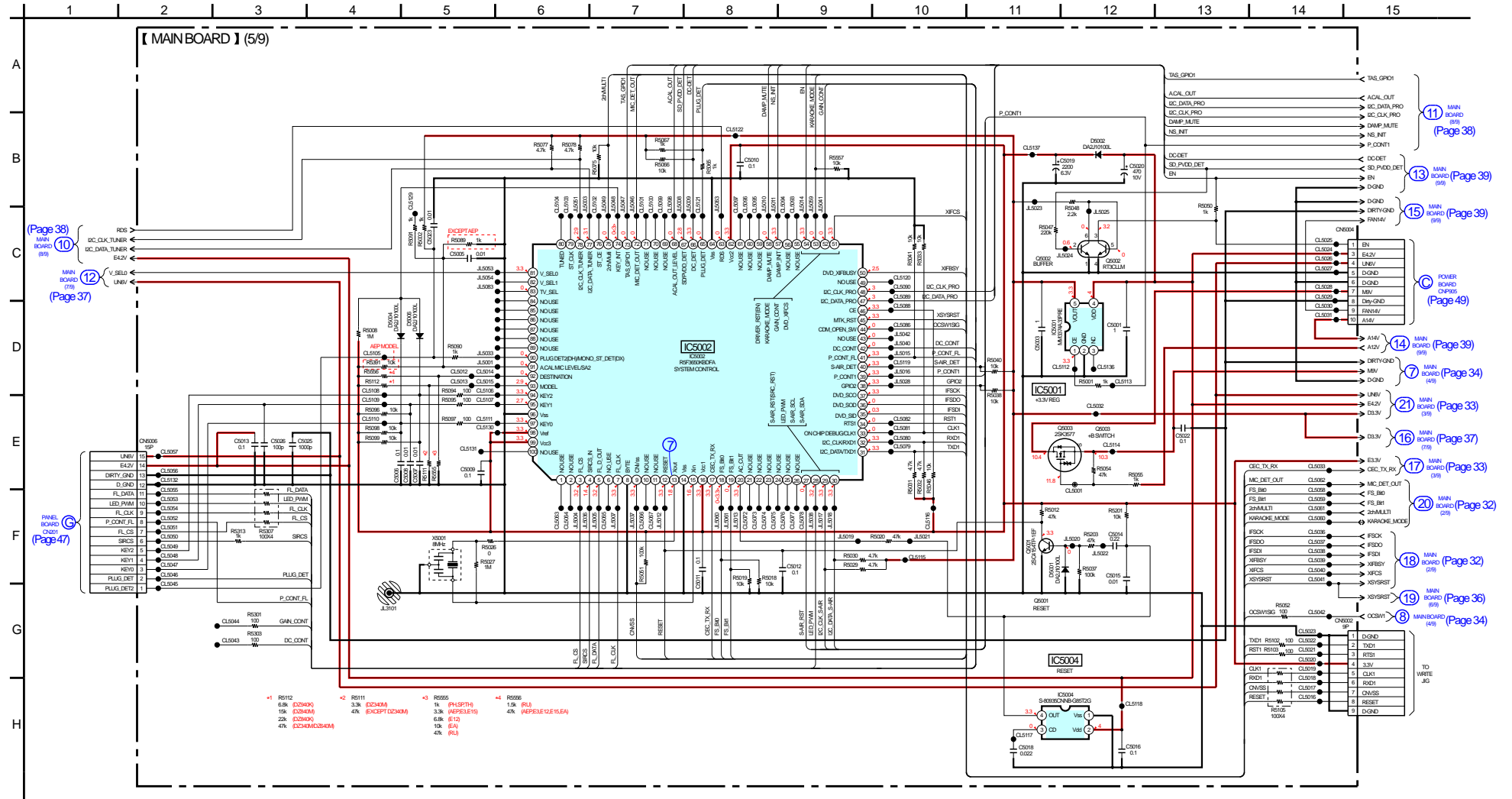

Note: When IC6001 on the Main board is damaged, exchange the new Main board for the Main board which IC damaged.

5-13. SCHEMATIC DIAGRAM – MAIN Section (6/9) – • See page 28 for waveforms. • See page 60 for IC Pin Function Description of IC6001.

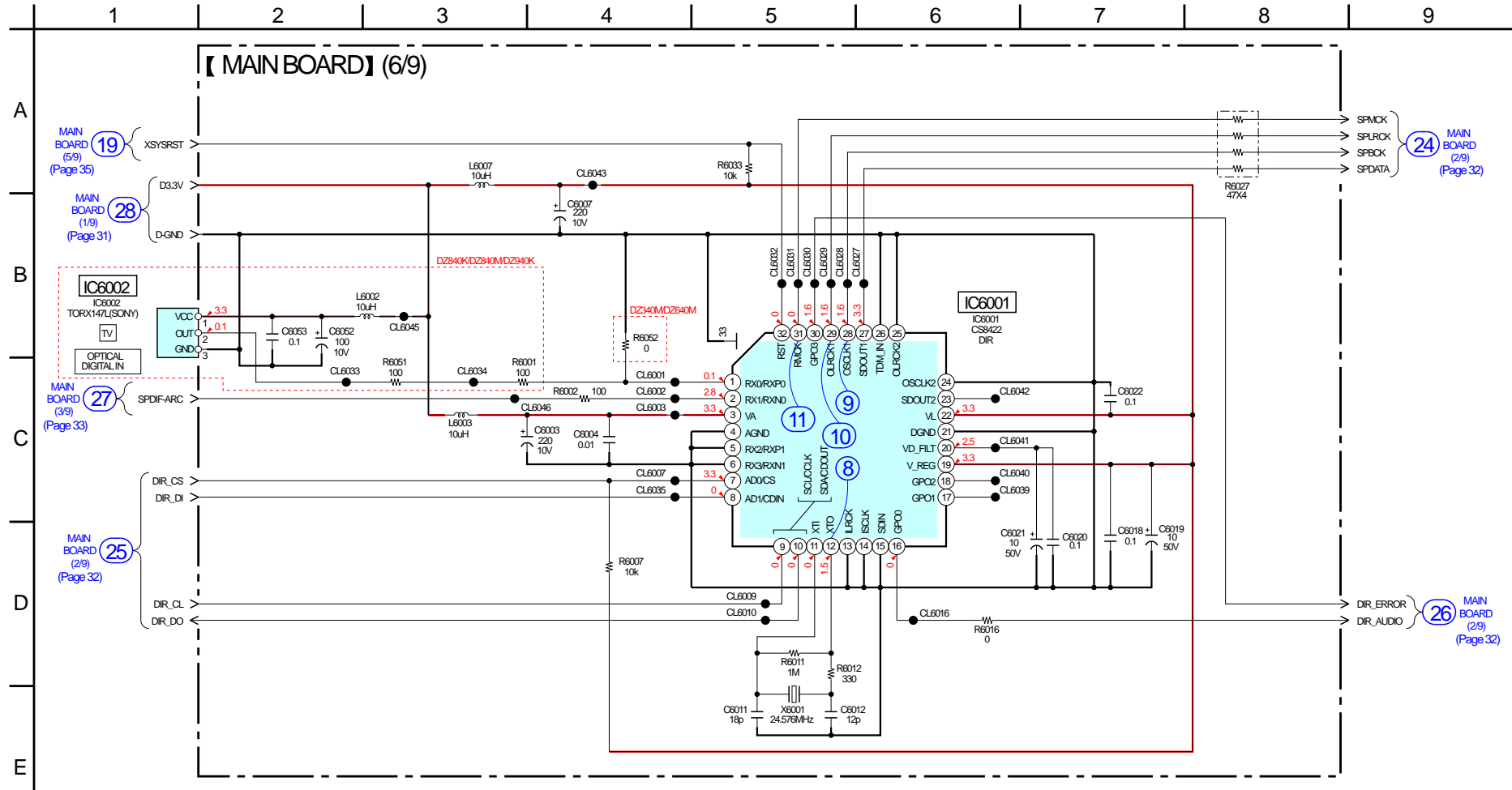

5-14. SCHEMATIC DIAGRAM – MAIN Section (7/9) – • See page 28 for waveforms. • See page 50 for IC Block Diagrams.

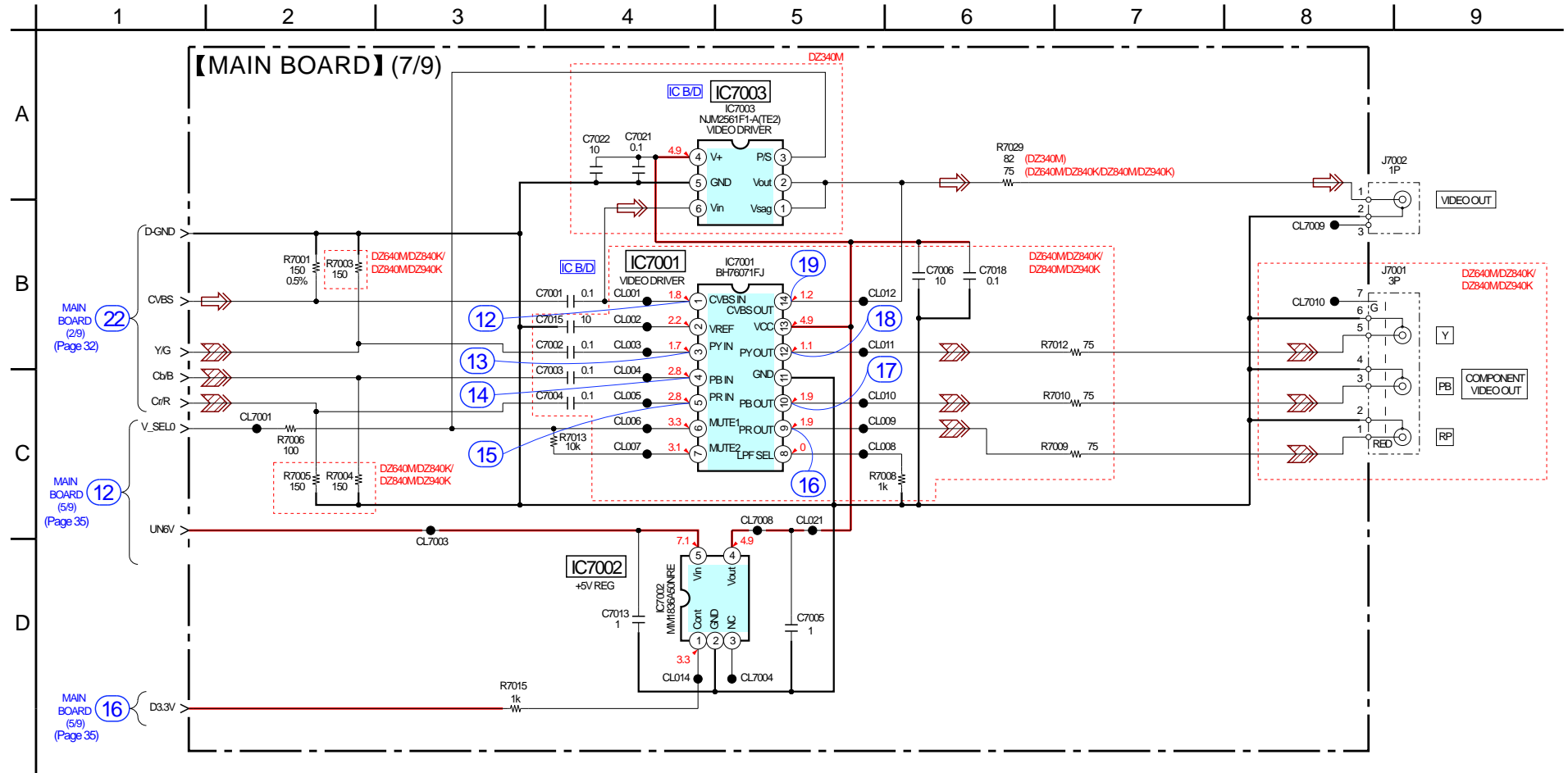

5-15. SCHEMATIC DIAGRAM – MAIN Section (8/9) – • See page 28 for waveform. • See page 61 for IC Pin Function Description of IC3001.

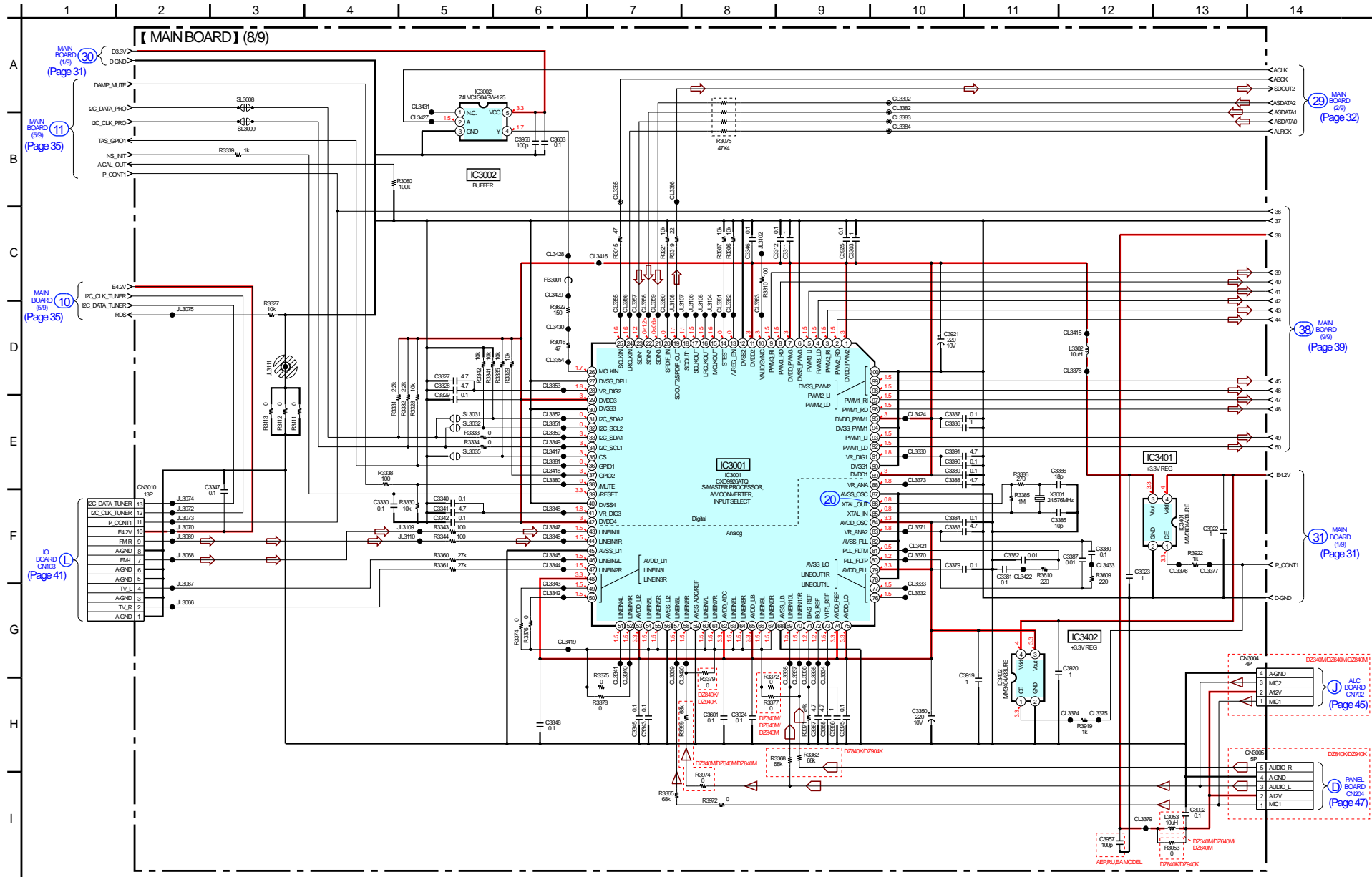

5-16. SCHEMATIC DIAGRAM – MAIN Section (9/9) – • See page 51 for IC Block Diagrams.

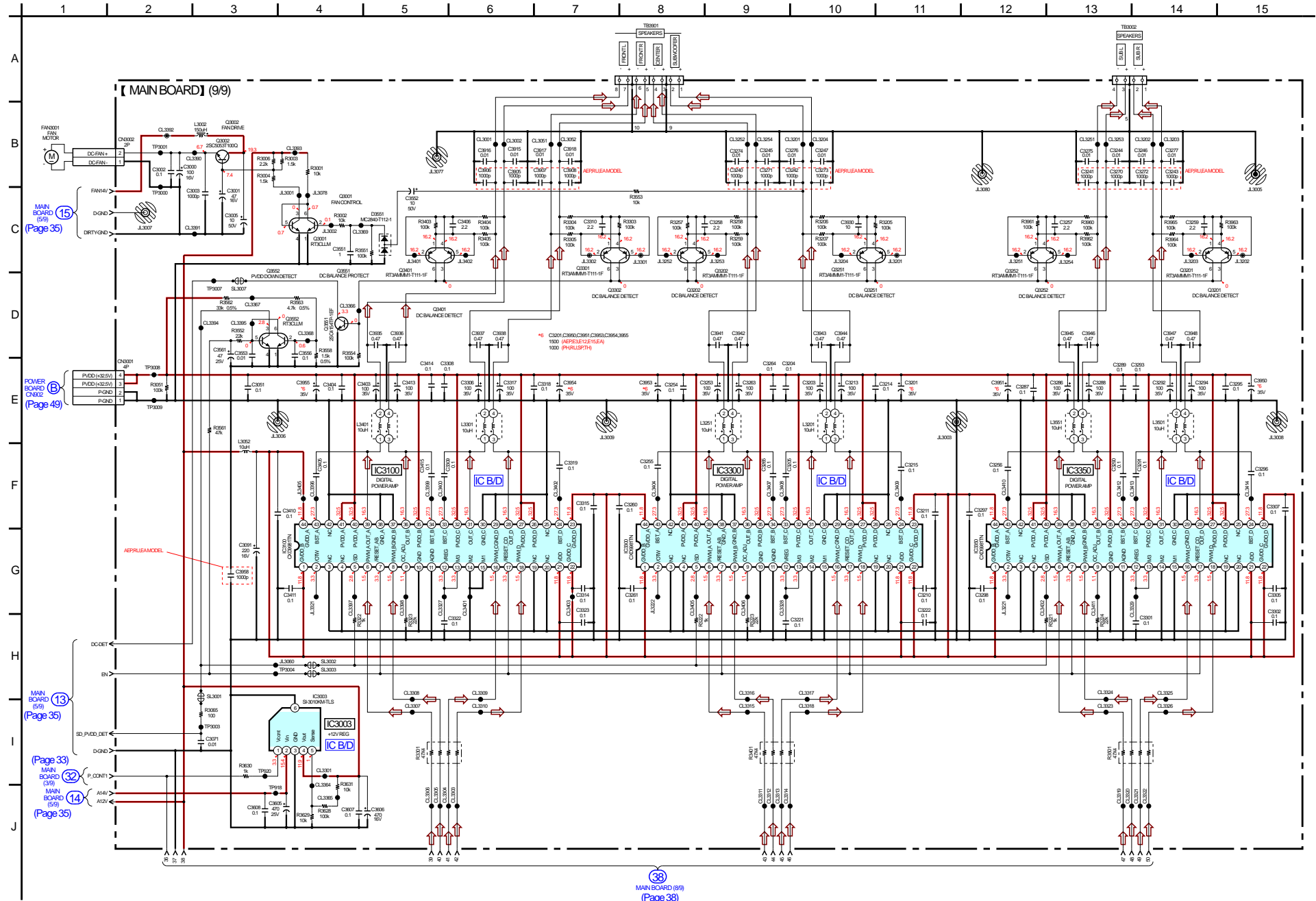

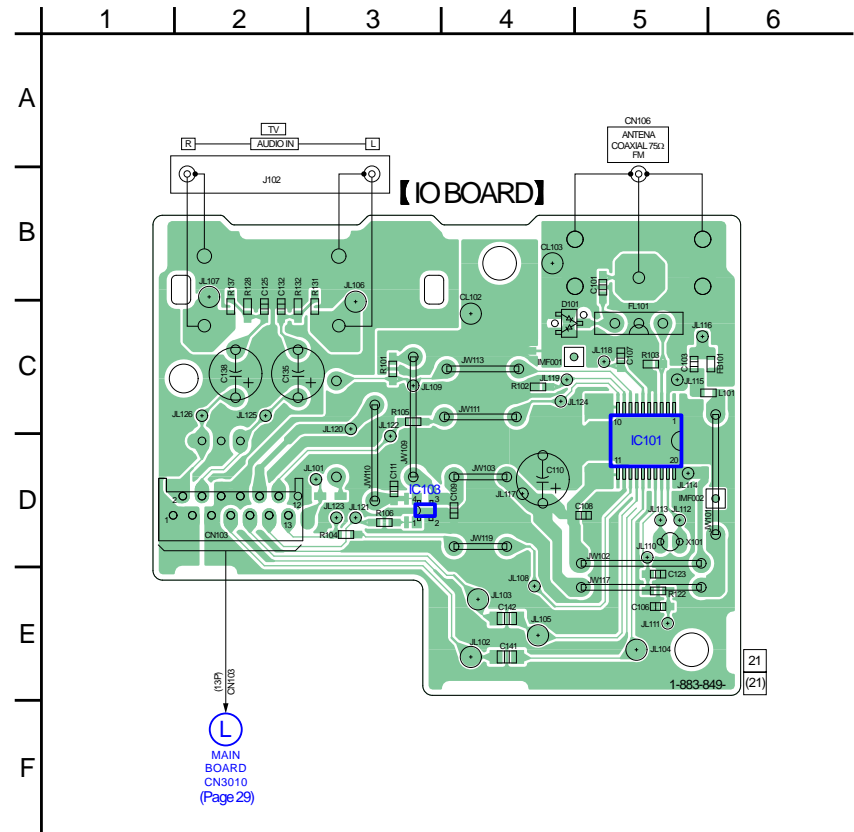

38 MAIN BOARD (9/9) (Page 38)

5-17. PRINTED WIRING BOARD – IO Section – • See page 22 for Circuit Boards Location. •  : Uses unleaded solder.

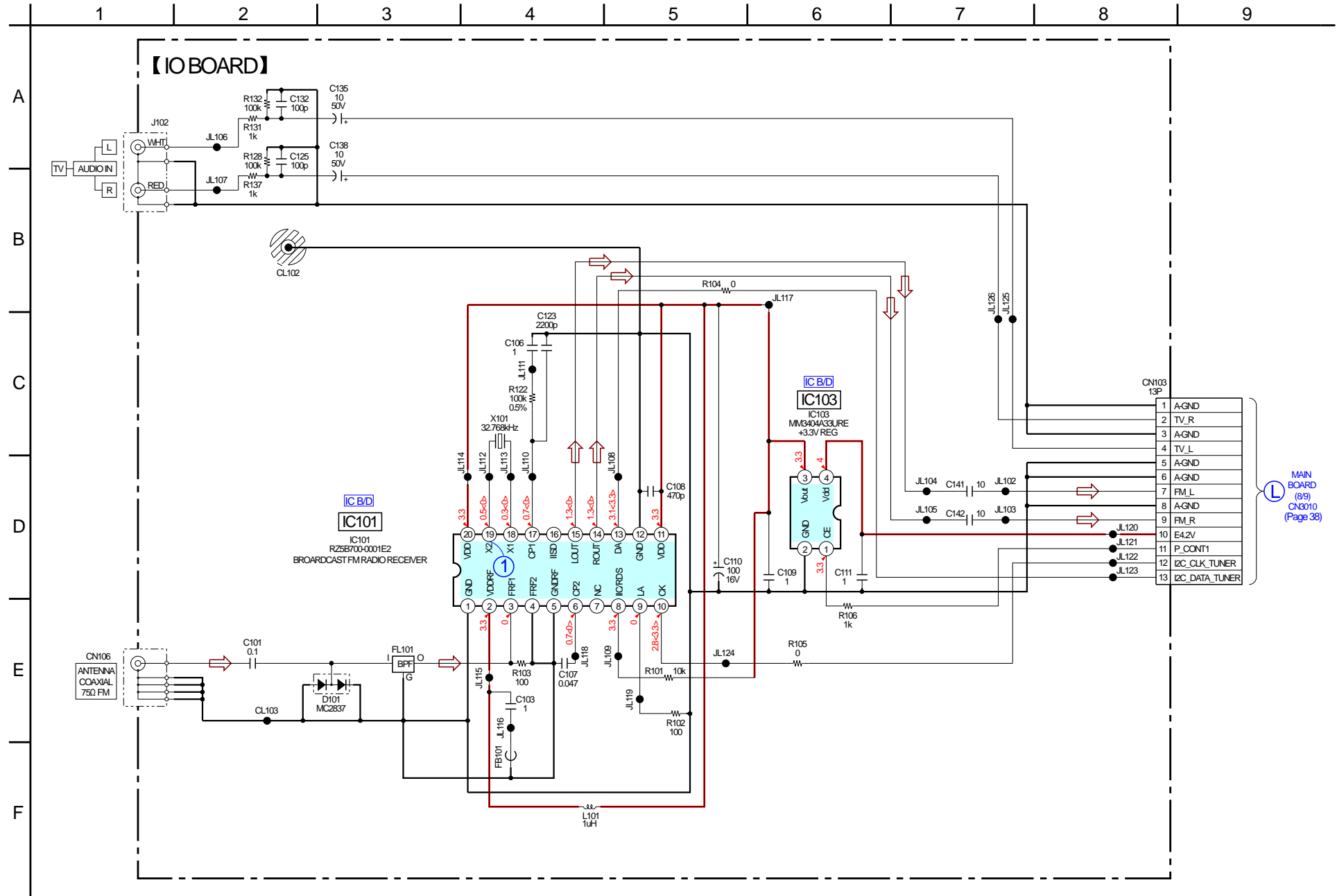

5-18. SCHEMATIC DIAGRAM – IO Section – • See page 28 for waveform. • See page 52, 53 for IC Block Diagrams.



5-19. PRINTED WIRING BOARDS – KEY, POWER KEY, LED Section – • See page 22 for Circuit Boards Location. •  : Uses unleaded solder.

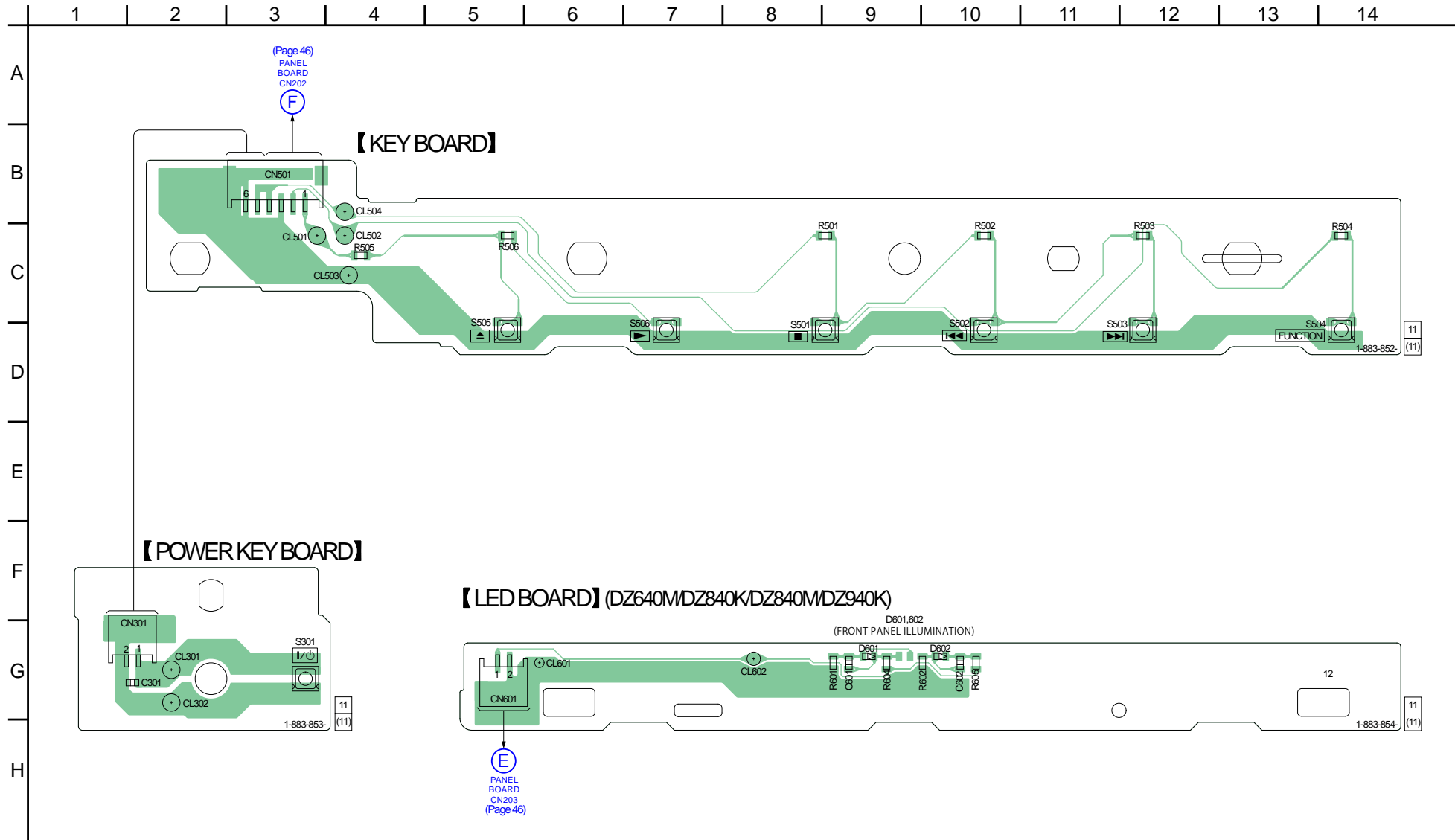

5-20. SCHEMATIC DIAGRAM – KEY, POWER KEY, LED Section –

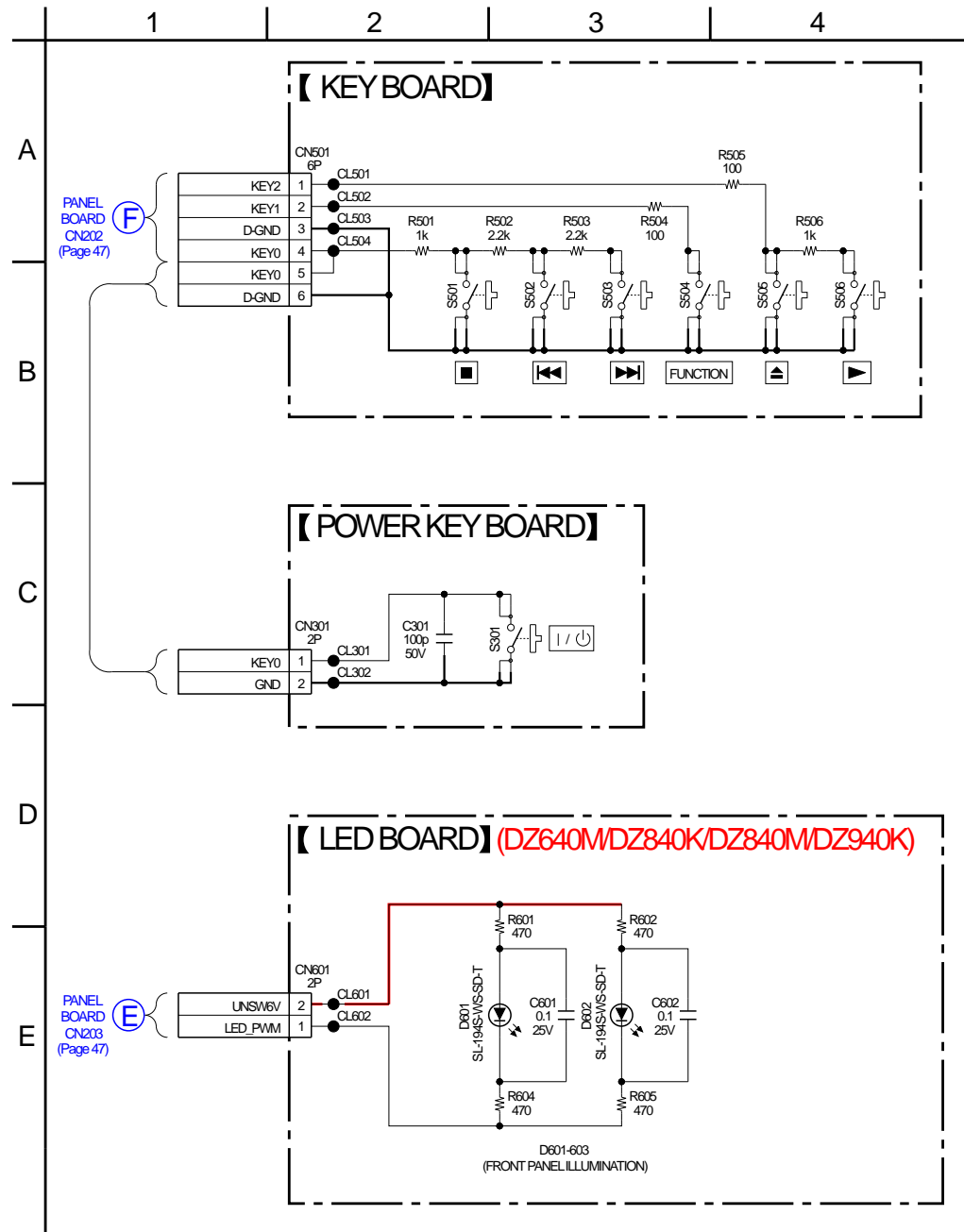

5-21. PRINTED WIRING BOARDS – ALC, USB, MS-203 Section – • See page 22 for Circuit Boards Location. •  : Uses unleaded solder.

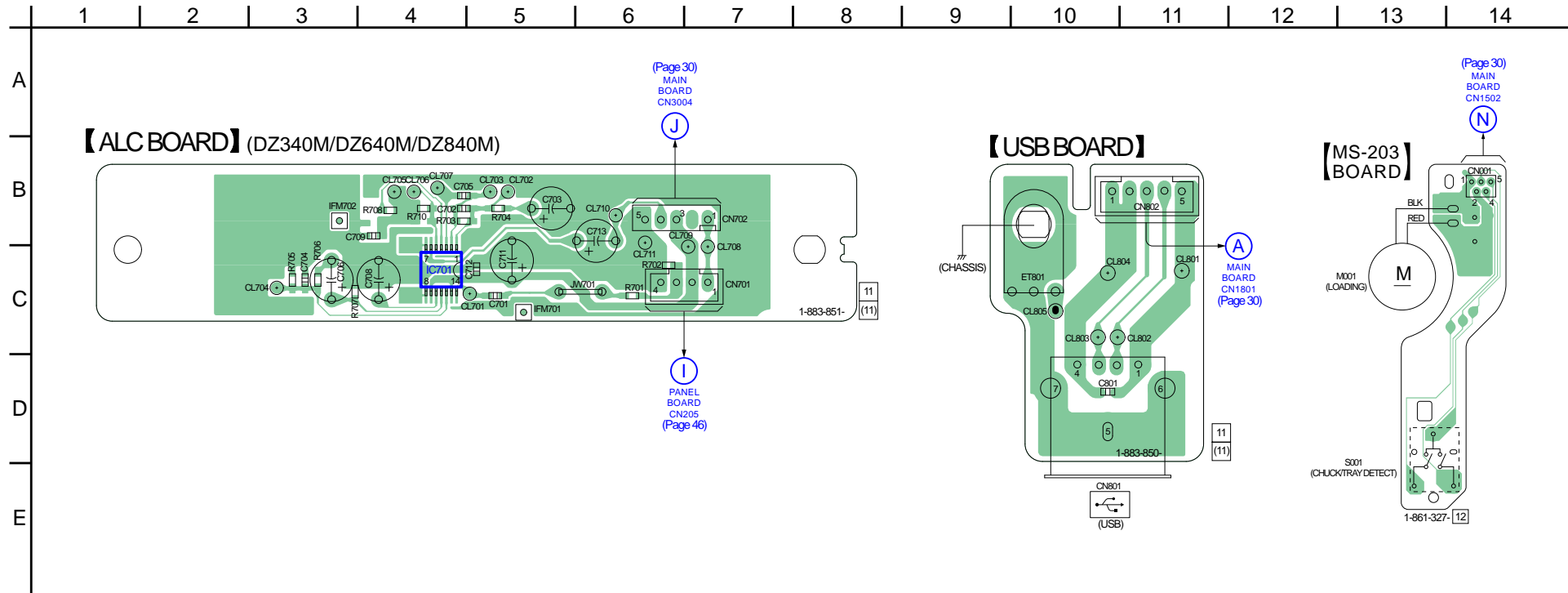

5-22. SCHEMATIC DIAGRAM – ALC, USB Section –

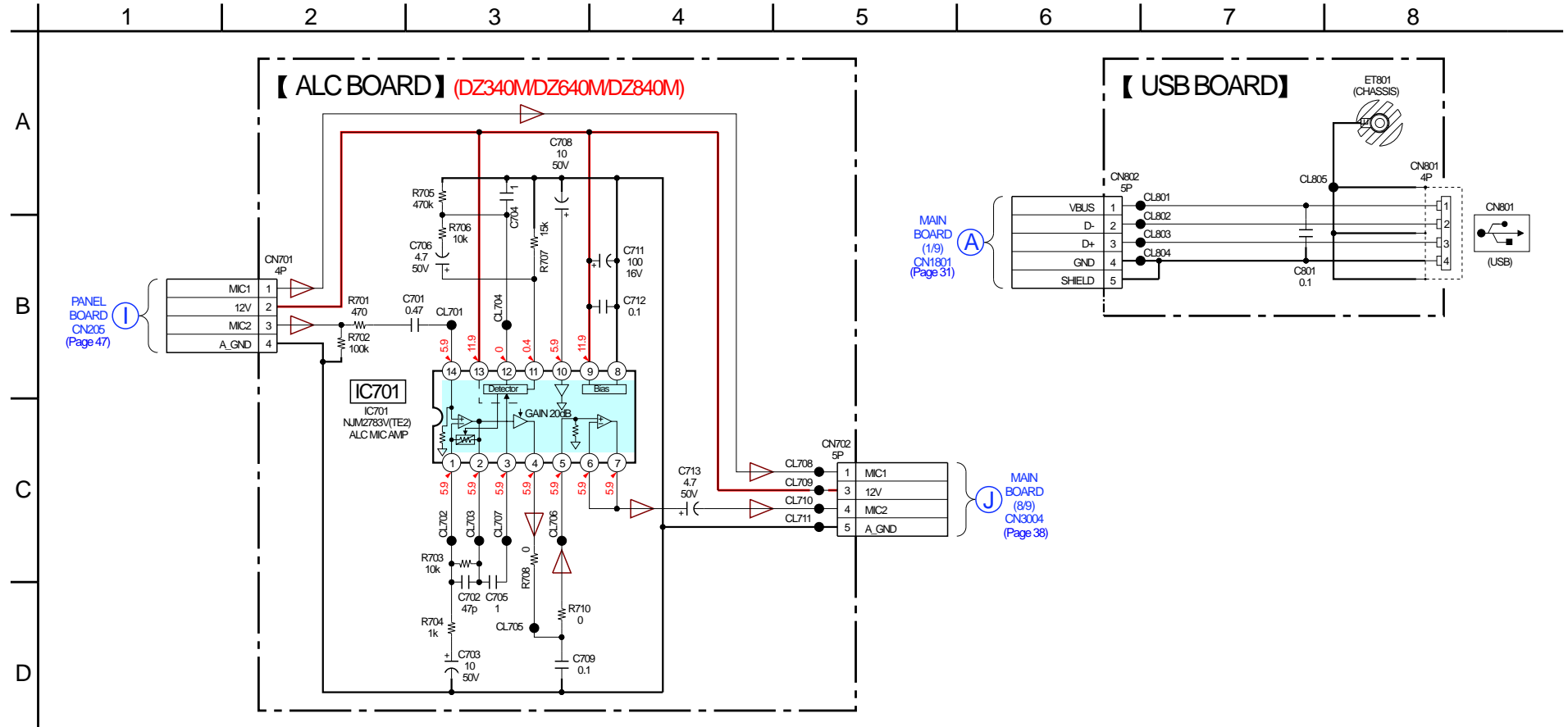

5-23. PRINTED WIRING BOARD – PANEL Section – • See page 22 for Circuit Boards Location. •  : Uses unleaded solder.

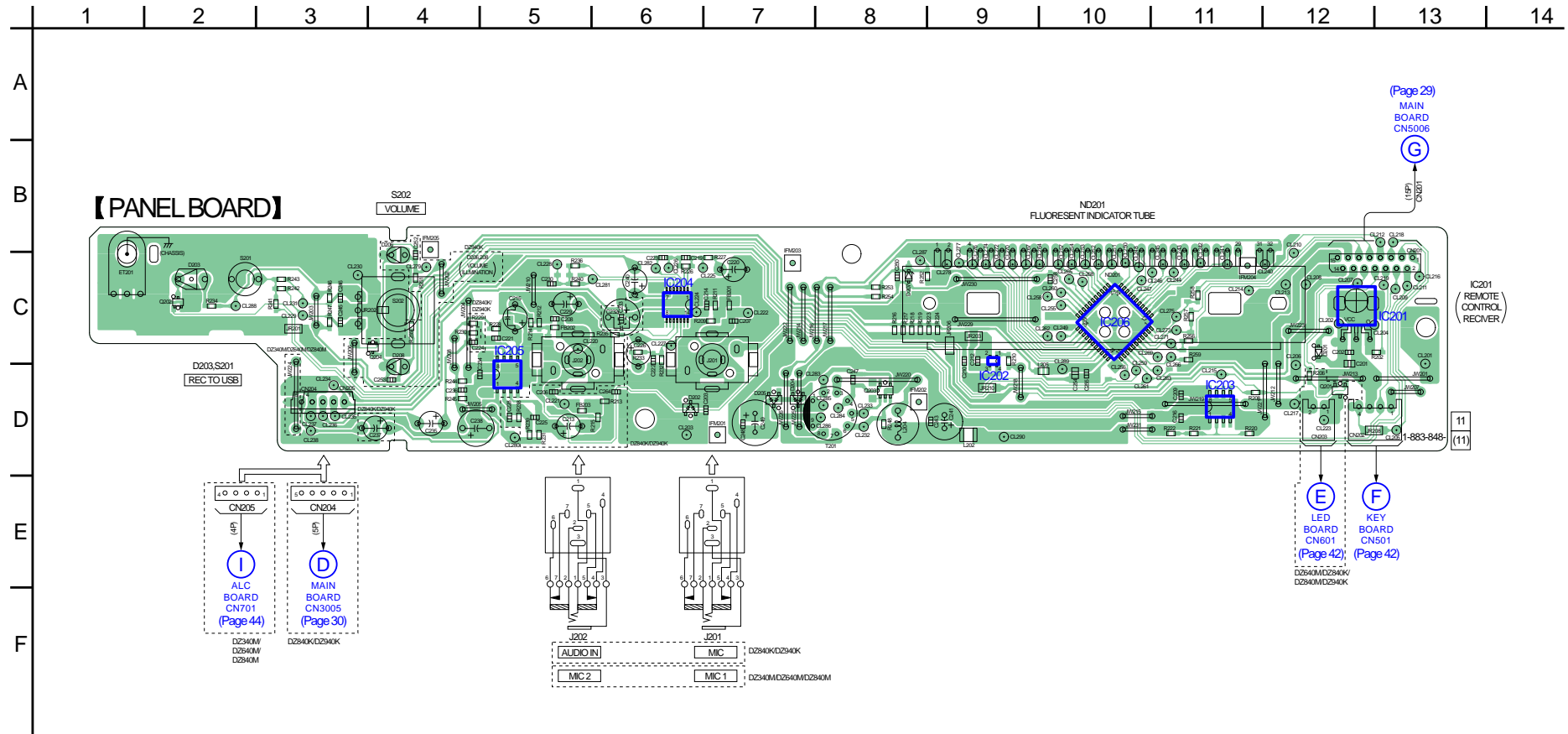

5-24. SCHEMATIC DIAGRAM – PANEL Section – • See page 53 for IC Block Diagram.

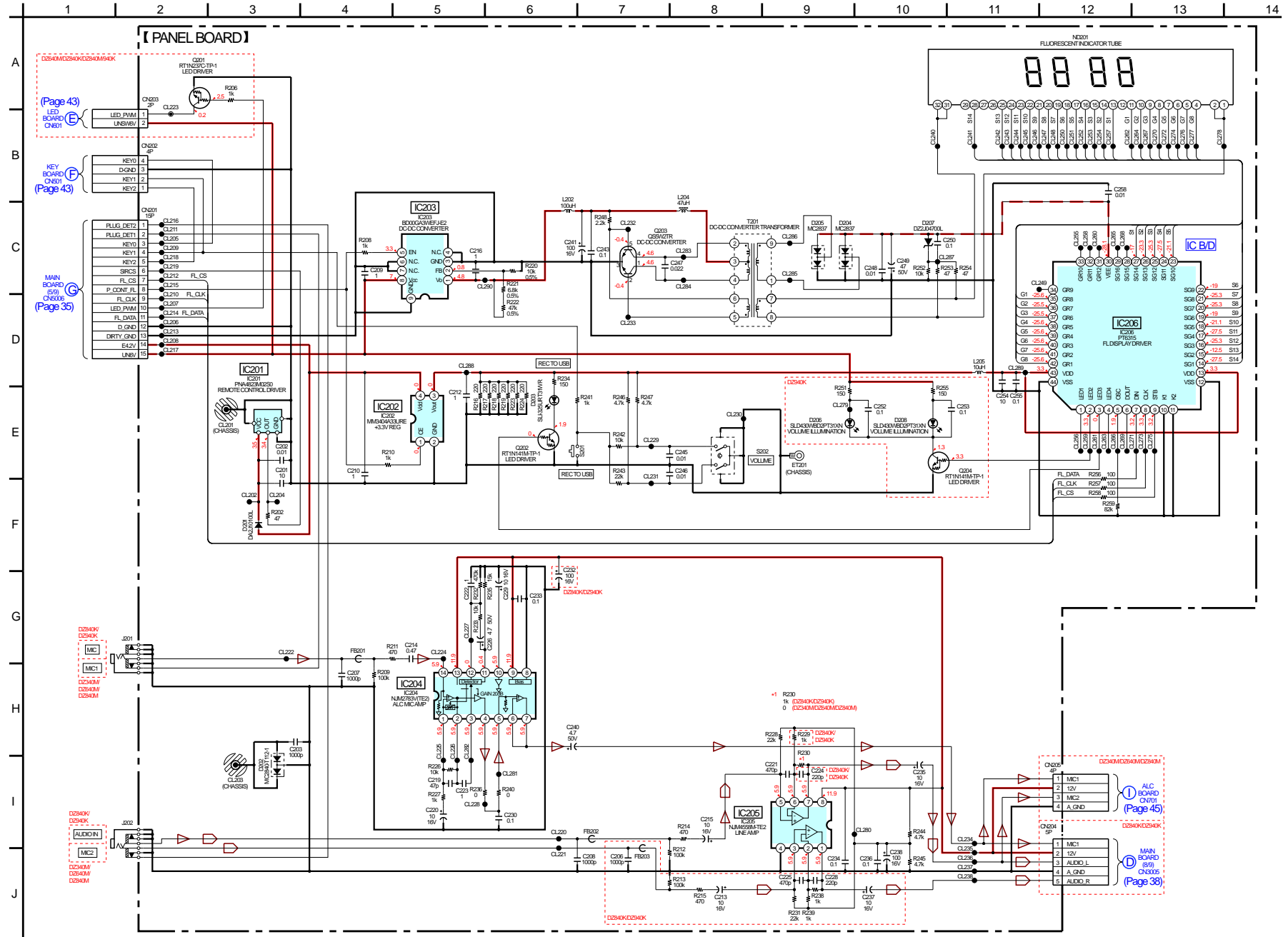

5-25. PRINTED WIRING BOARD – POWER Section – • See page 22 for Circuit Boards Location. •  : Uses unleaded solder.

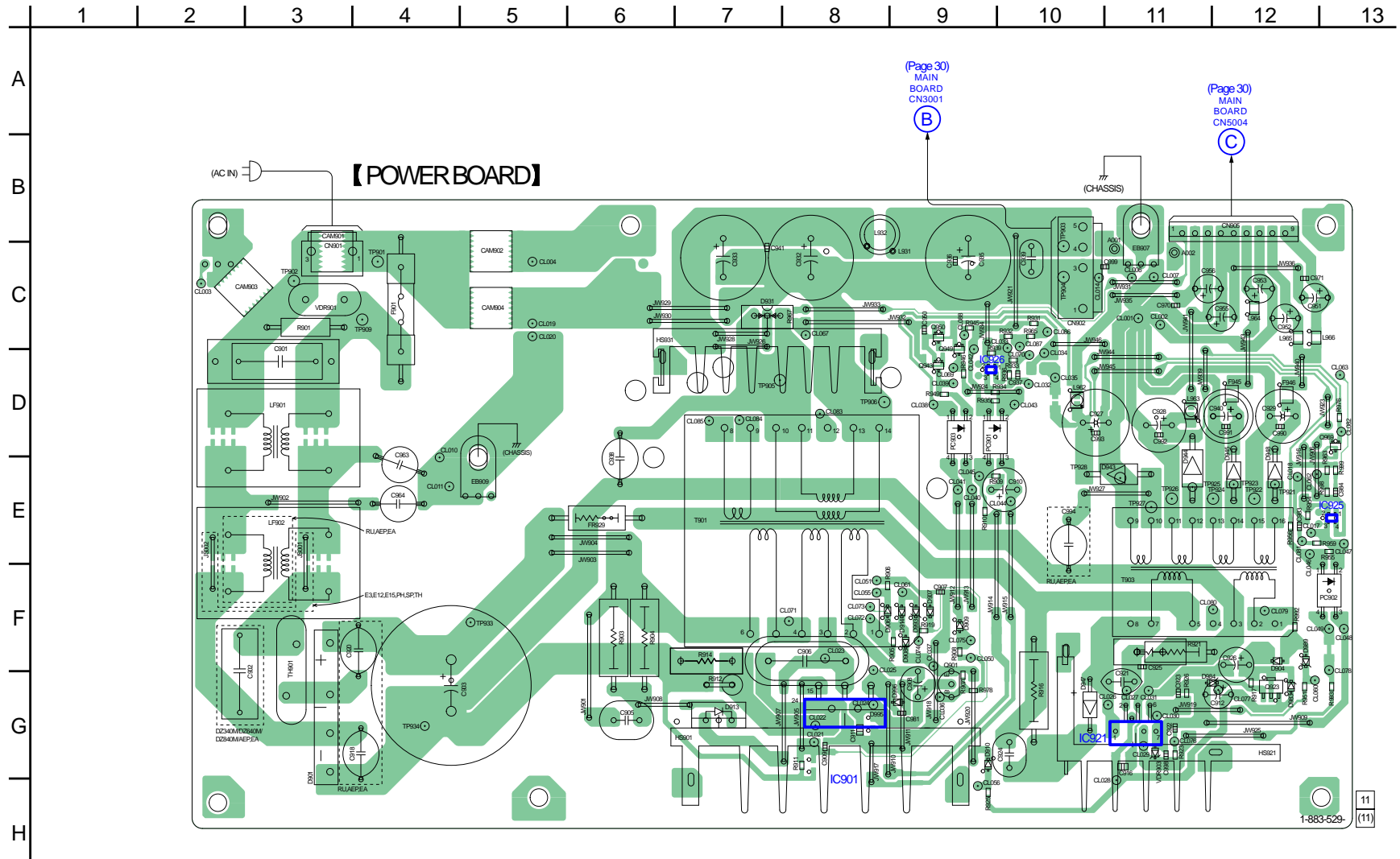

5-26. SCHEMATIC DIAGRAM – POWER Section – • See page 52 for IC Block Diagrams.

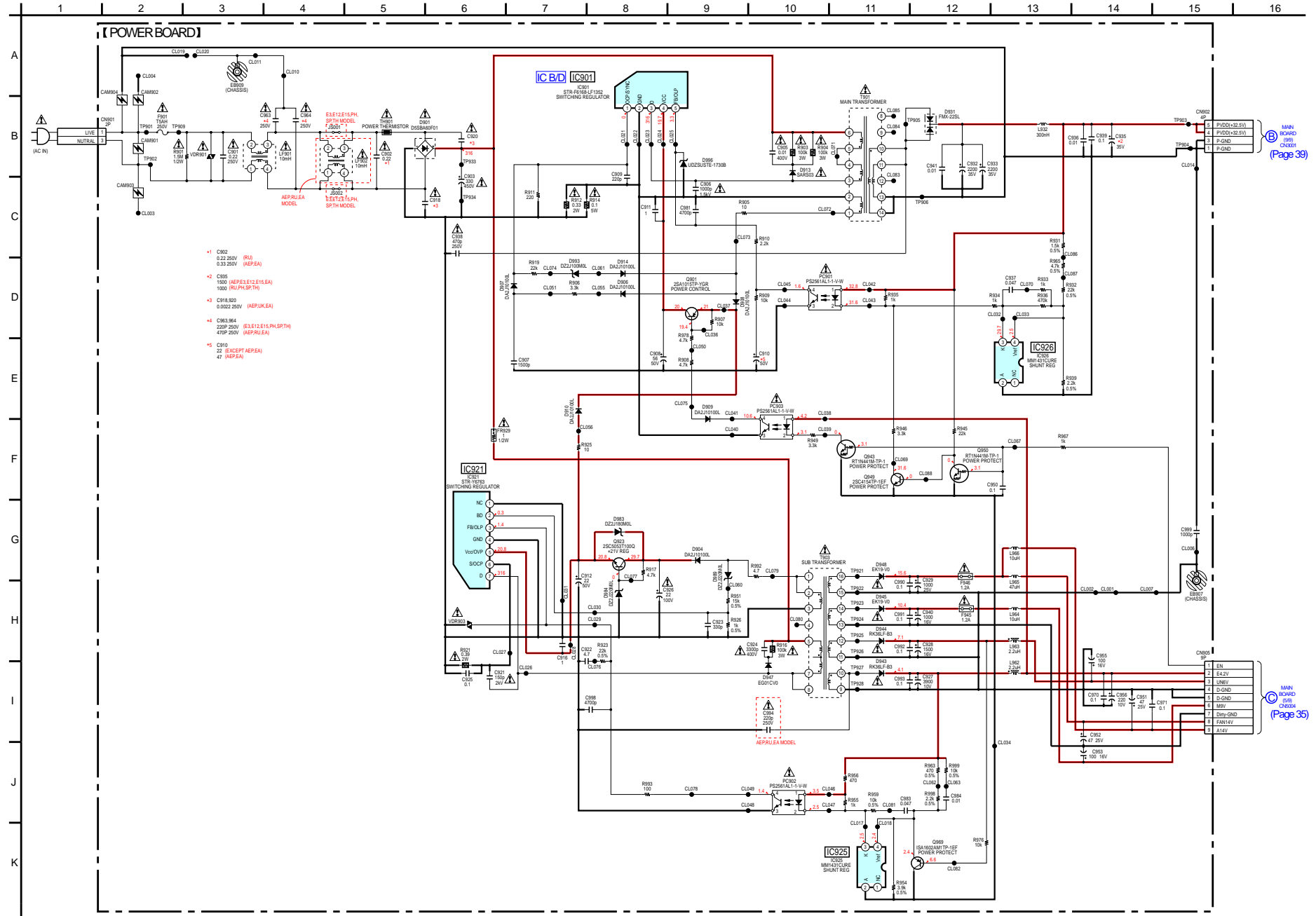

• IC Block Diagrams

IC1707 TK11150CSSL-G (MAIN Board (3/9))
IC1708 TK11133CSSL-G (MAIN Board (3/9))

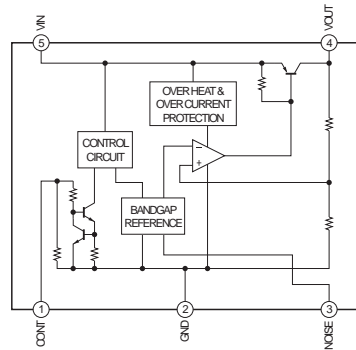

IC7001 BH76071FJ-E2 (MAIN Board (7/9))

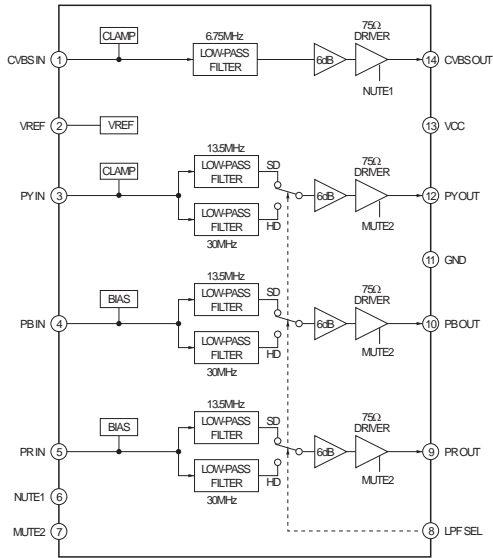

IC1501 BD8203EFV-E2 (MAIN Board (4/9))

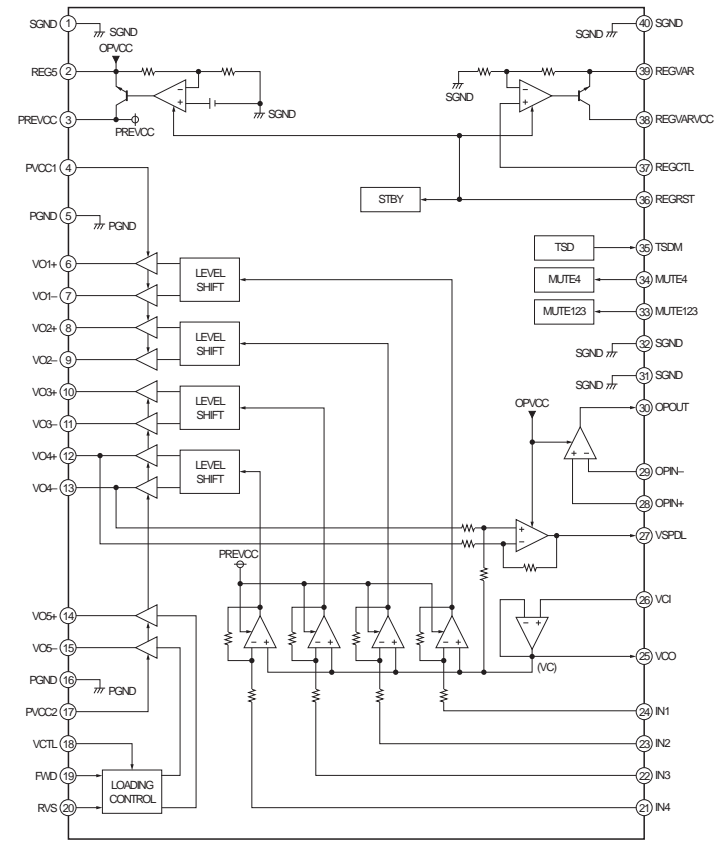

IC7003 NJM2561F1-A (TE2) (MAIN Board (7/9))

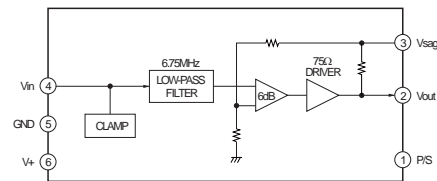

IC3100 CXD9981TN (MAIN Board (9/9))
 IC3300 CXD9981TN (MAIN Board (9/9))
 IC3350 CXD9981TN (MAIN Board (9/9))

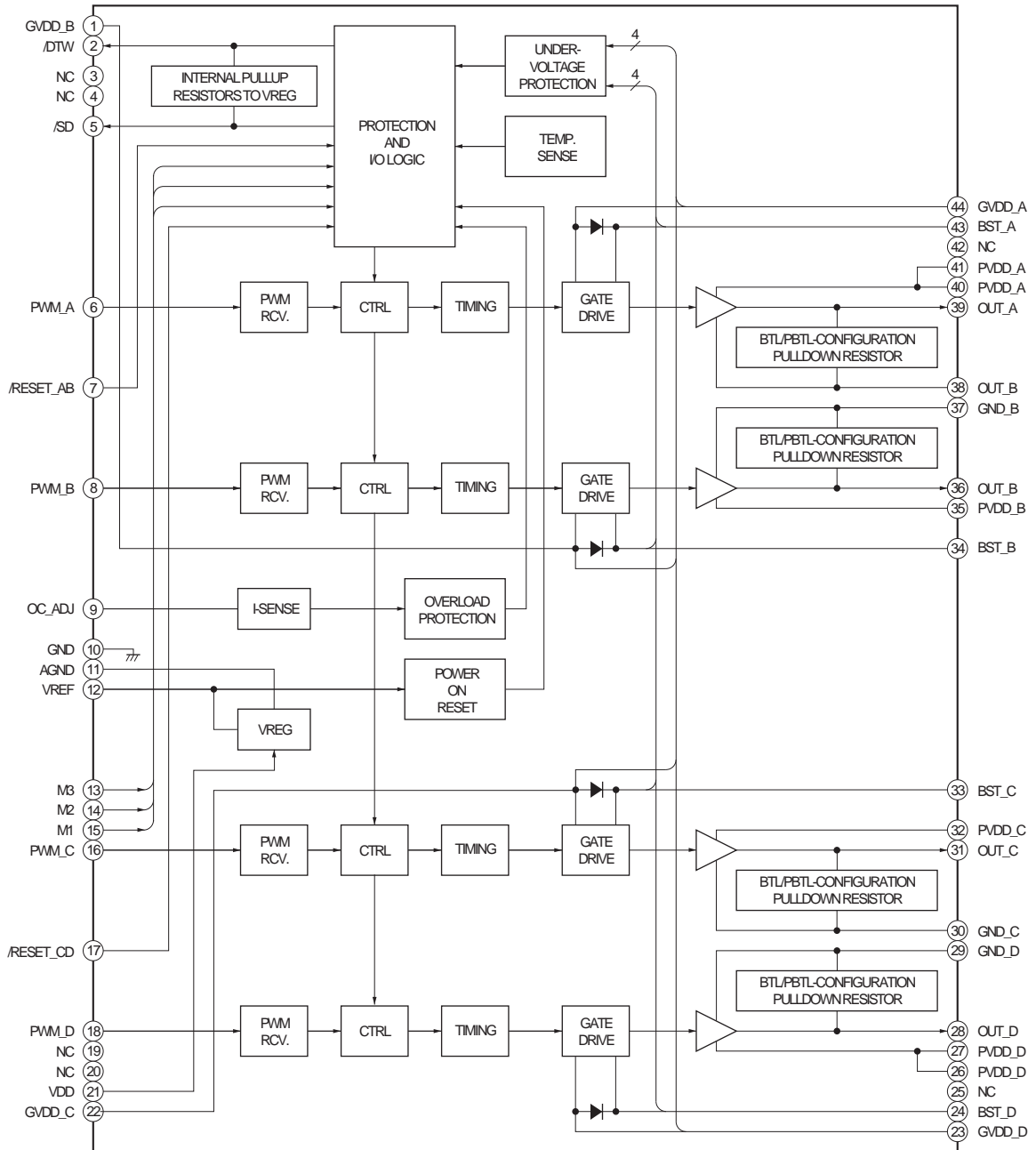

IC3003 SI-3010KM-TLS (MAIN Board (9/9))

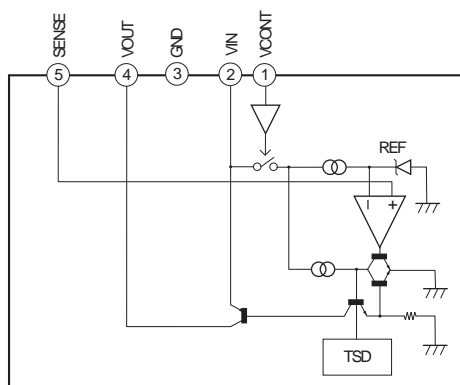

IC101 RZ5B700-0001E2 (IO Board)

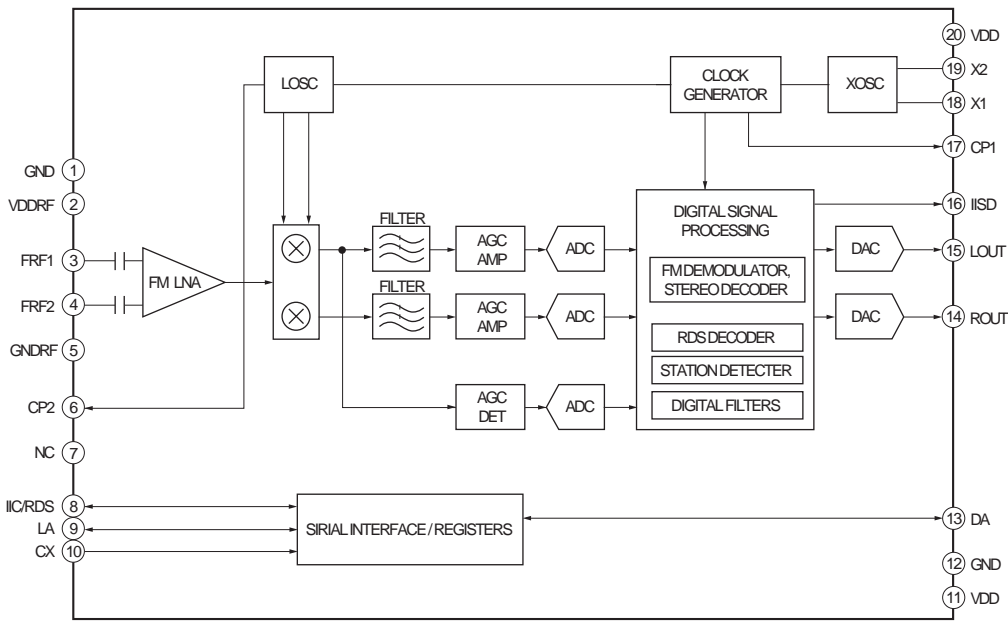

IC901 STR-F6168-LF1352 (POWER Board)

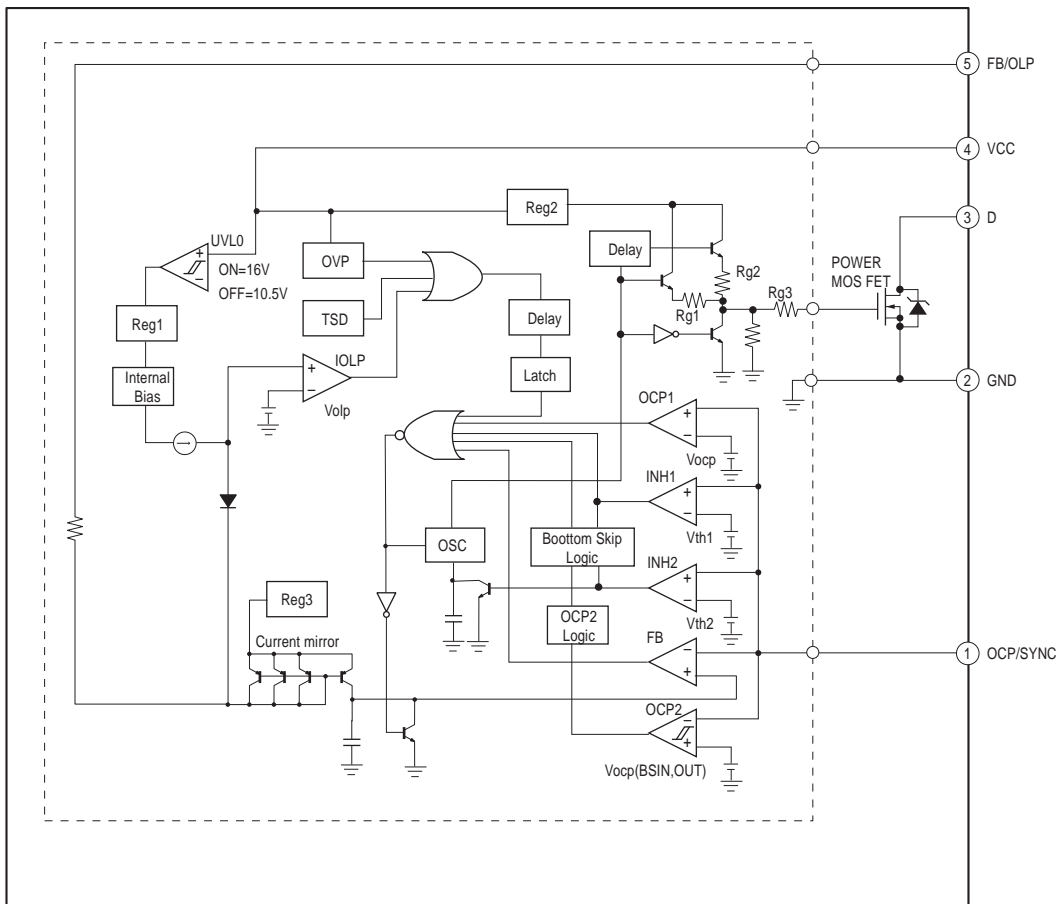

IC103 MM3404A33URE (IO Board)

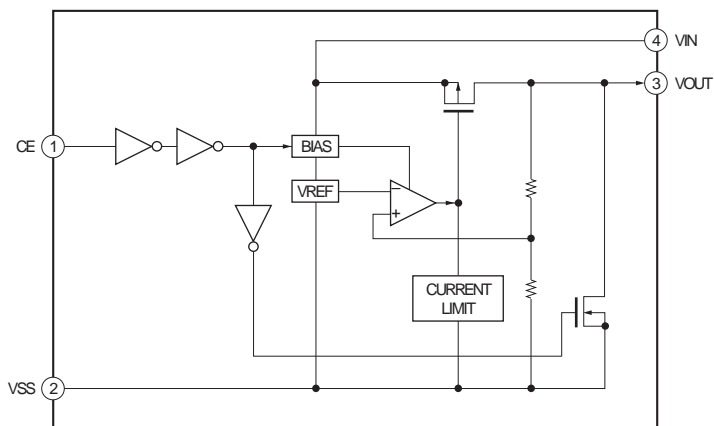

IC206 PT6315 (PANEL Board)

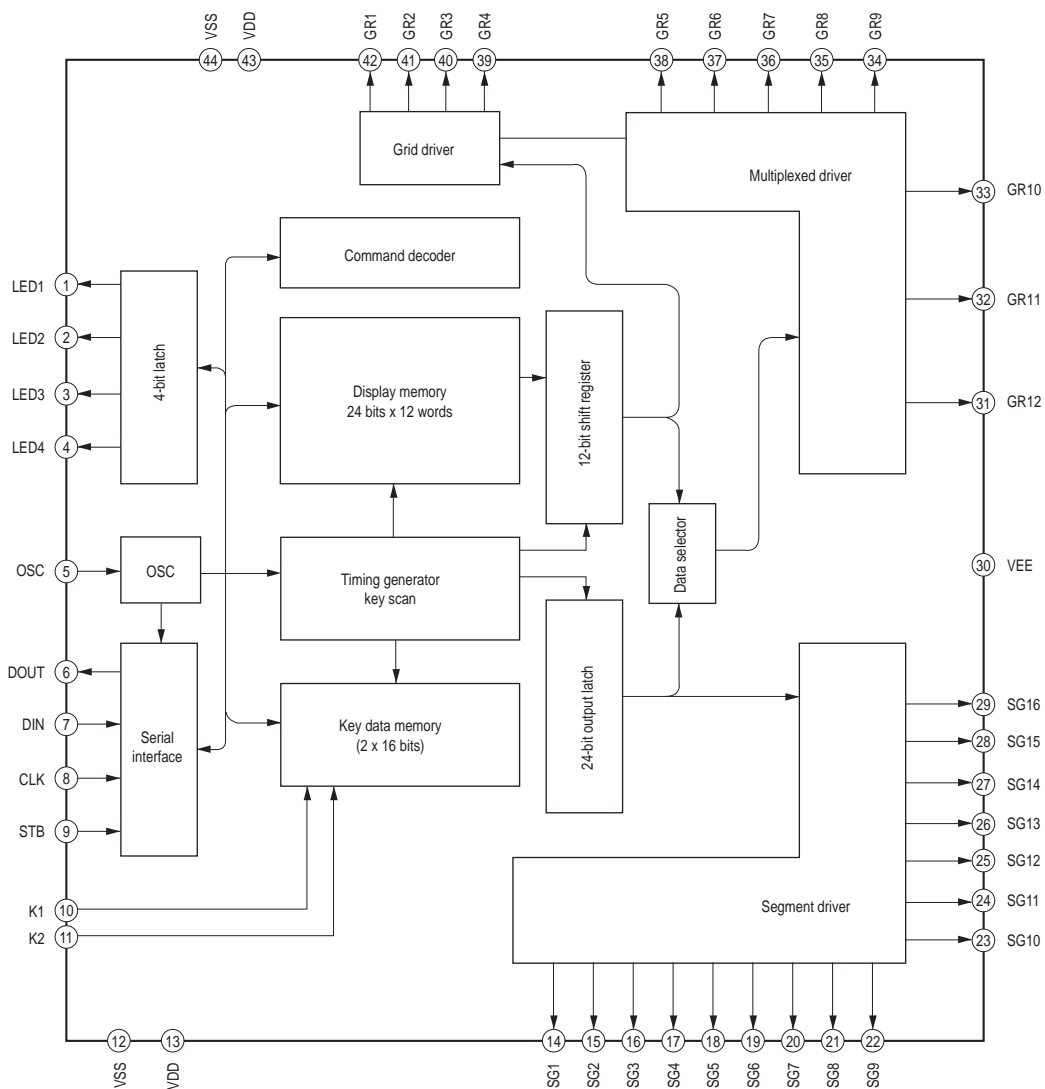

• IC Pin Function Description

MAIN BOARD (2/9) IC1101 CXD9927R-B

(CD/DVD RF AMP, FOCUS/TRACKING ERROR AMP, DVD SYSTEM CONTROL, DSP, DIR/USB/HDMI CONTROL)

Pin No.	Pin Name	I/O	Description
1	OSN	—	RF offset cancellation capacitor connecting terminal
2	RFGC	I	RF AGC loop capacitor connecting terminal
3	IREF	I	Current reference setting terminal
4	AVDD3	—	Power supply (VDD3.3V)
5	AGND	—	Ground
6	DVDA	I	AC coupled input path A
7	DVDB	I	AC coupled input path B
8	DVDC	I	AC coupled input path C
9	DVDD	I	AC coupled input path D
10	DVDRFIP	I	DC coupled DVD RF signal input RFIP
11	MA	I	DC coupled main-beam RF signal input A
12	MB	I	DC coupled main-beam RF signal input B
13	MC	I	DC coupled main-beam RF signal input C
14	MD	I	DC coupled main-beam RF signal input D
15	SA	—	Not used. (Open)
16	SB	—	Not used. (Open)
17	TNI	I	DC coupled main-beam RF signal input E
18	TPI	I	DC coupled main-beam RF signal input F
19	MDI1	I	Laser power monitor input
20	MDI2	I	Laser power monitor input
21	LDO2	O	Laser diode (DVD) drive signal output
22	LDO1	O	Laser diode (CD) drive signal output
23	SVDD3	—	Power supply (RF+3.3V)
24	CSO	O	Not used. (Open)
25	RFLVL	O	RFRP low pass output
26	SGND	—	Ground
27	V2REFO	O	Reference voltage (2.8V) output
28	V20	O	Reference voltage (2.0V) output
29	VREFO	O	Reference voltage (1.4V) output
30	FEO	O	Focus error monitor output
31	TEO	O	Tracking error monitor output
32	TEZISLV	O	TE Slicing Level output
33	OP_OUT	O	Op amp output
34	OP_INN	I	Op amp negative input
35	OP_INP	I	Spindle feedback signal input
36	DMO	O	Spindle motor control PWM signal output
37	FMO	O	Sled motor control PWM signal output
38	TROPENPWM	O	Tray Loading motor PWM signal output
39	IOPMON	I	Iop Monitor input
40	TRO	O	Tracking servo control signal output
41	FOO	O	Focus servo control signal output
42	AGND18	—	Ground
43	AVDD18	—	Power supply (+1.8V)
44	USB_DP	I/O	USB port serial data input/output
45	USB_DM	I/O	USB port serial data input/output
46	USB_VDD3	—	USB power supply (+3.3V)
47	USB_VSS	—	USB ground
48	PAD_VRT	—	Not used. (Pull up)
49	USB_VDD18	—	Power supply (+1.8V)
50	USB_VSS	I	Ground
51	DIR_ERROR/NC	I	DIR PLL error signal input
52	DIR_AUDIO/NC	I	DIR audio signal input
53	LIMITSW	I	LIMIT SW signal input
54	MSW	O	DVD/CD PD -VR select signal output
55	DVDD18	—	Power supply (+1.8V)
56 to 62	HA2 to HA8	O	Flash ROM address bus A2 to A8 output

Pin No.	Pin Name	I/O	Description
63, 64	HA18, HA19	O	Flash ROM address bus A18, A19 output
65	DVDD3	—	Power supply (+3.3V)
66	XWR	O	Flash ROM write signal output
67 to 74	HA16 to HA9	O	Flash ROM address bus A16 to A9 output
75	HA20		Flash ROM address bus A20 output
76	XROMCS	O	Flash ROM chip select signal output
77	HA1	O	Flash ROM address bus A1 output
78	XRD	O	Flash ROM read signal output
79, 80	HD0, HD1	I/O	Flash ROM data bus D0, D1 input/output
81	DVSS	—	Ground terminal
82 to 86	HD2 to HD6	I/O	Flash ROM data bus D2 to D6 input/output
87	HA21	I/O	Flash ROM data bus D21 input/output
88	RESERVED	—	Not used. (Open)
89	HD7	I/O	Flash ROM data bus D7 input/output
90	DVSS	—	Ground
91, 92	HA17, HA0	O	Flash ROM address bus A17, A0 output
93	DVDD18	—	Power supply (+1.8V)
94	FWD	O	Tray loading motor control (FWR) signal output
95	REV	O	Tray loading motor control (REV) signal output
96	DVDD3	—	Power supply (+3.3V)
97	IFSDO	O	CPU I/F serial data output
98	IFCK	O	CPU I/F serial clock output
99	xIFCS	O	CPU I/F chip select output
100	IFSDI	I	CPU I/F serial data input
101	SCL	O	EEPROM serial clock output
102	SDA	I/O	EEPROM serial data input/output
103	CKSW	I	Chuck/Tray detect switch signal input
104	OCSW	I	Chuck/Tray detect switch signal input
105	RXD	I	RXD signal input from Jig
106	TXD	O	TXD signal output to Jig
107	ICE	O	Not used. (Open)
108	xSYSRST	I	System reset signal input
109	RESERVED	I	Not used. (Open)
110	xIFBSY	I	Busy signal input from CPU I/F
111	DQM0	O	SDRAM lower byte mask enable signal output
112	EEWP	O	EEPROM ready/Busy wake up signal output
113 to 117	RD7 to RD3	I/O	SDROM data bus D7 to D3 input/output
118	DVDD3	—	Power supply (+3.3V)
119 to 121	RD2 to RD0	I/O	SDROM data bus D2 to D0 input/output
122 to 129	RD15 to RD8	I/O	SDROM data bus D15 to D8 input/output
130	TSD_M	I	TSD signal input
131	DVDD3	—	Power supply (+3.3V)
132	DQM1	O	SDRAM upper byte mask enable signal output
133	_RWE	O	SDRAM write enable signal output
134	_CAS	O	SDRAM column address strobe signal output
135	_RAS	O	SDRAM row address strobe signal output
136	_RCS	O	SDRAM chip select signal output
137, 138	BA0, BA1	O	SDRAM bank address 0, 1 output
139	RA10	O	SDRAM address bus A10 output
140, 141	RA0, RA1	O	SDRAM address bus A0, A1 output
142	DVDD18	—	Power supply (+1.8V)
143, 144	RA2, RA3	O	SDRAM address bus A0, A3 output
145	DVDD3	—	Power supply (+3.3V)
146	DRCLK	O	SDRAM clock output
147	CKE	O	SDRAM clock enable signal output
148	DVSS	—	Ground
149	RA11	O	SDRAM address bus A11 output
150 to 155	RA9 to RA4	O	SDRAM address bus A9 to A4 output
156	DVDD3	—	Power supply (+3.3V)

HBD-DZ340M/DZ640M/DZ840K/DZ840M/DZ940K

Pin No.	Pin Name	I/O	Description
157	REGRST	O	REG reset signal output for Focus/Tracking/Sledding motor driver
158	MUTE	O	Mute signal output for Spindle motor
159	DDC_DA	I/O	HDMI DDC line data input/output
160	DVDD18	—	Power supply (+1.8V)
161	DDC_CLK	I/O	HDMI DDC line clock input/output
162	HTPLG	I	HDMI HPD signal input
163	AGND3	—	Ground
164	EXT_RES	—	Ext. resistor connected terminal
165, 166	AVDD3	—	Power supply (+3.3V)
167	EXT_CAP	—	Ext. capacitor connected terminal
168, 169	AGND3, AGND18	—	Ground
170	TXCN	O	HDMI TXD-clock output
171	TXCP	O	HDMI TXD-clock output
172	AVDD18	—	Power supply (+1.8V)
173	TX0N	O	HDMI TXD-0 output
174	TX0P	O	HDMI TXD-0 output
175	AGND18	—	Power supply (+1.8V)
176	TX1N	O	HDMI TXD-1 output
177	TX1P	O	HDMI TXD-1 output
178	AVDD18	—	Power supply (+1.8V)
179	TX2N	O	HDMI TXD-2 output
180	TX2P	O	HDMI TXD-2 output
181	AGND18	—	Power supply (+1.8V)
182	R/Cr/Pr	O	Video chroma R/Cr/Pr signal output
183	B/Cb/Pb	O	Video chroma B/Cb/Pb signal output
184	DACVSSA	—	Ground
185	Y/G	O	Video Y/chroma G signal output
186	DACVDDA	—	Power supply (+3.3V)
187	CVBS	O	Video Composite signal output
188	DACVSSB	—	Ground
189	C	O	Video chroma signal output (Not used in this set)
190	DACVddb	—	Power supply (+3.3V)
191	Y	O	Video Y signal output (Not used in this set)
192	DACVSSC	—	Ground
193	FS	I	Full Scale Adjustment setting terminal
194	VREF	I	Reference Voltage input terminal
195	DACVDDC	—	Power supply (+3.3V)
196	VBUS_OE	O	VBUS power control signal output
197	VBUS_OC	I	VBUS over current detect signal input
198	KARAOKE_MODE	O	Karaoke mode information signal output
199	SPMCK	I	DIR MCK clock input
200	SPBCK	I	DIR BCK clock input
201	SPLRCK	I	DIR LACK clock input
202	ADIN (SPDATA)	I	DIR digital data input
203	ACLK	O	A/D converter and DAMP clock output
204	ABCK	O	A/D converter and DAMP BCK clock output
205	ALRCK	O	A/D converter and DAMP LRCK clock output
206	MC_DATA (ADIN)	I	A/D converter digital data input
207	DVDD3	—	Power supply (+3.3V)
208	FS_Bit1	O	FS Bit1 signal output
209	WIDE	O	WIDE select signal output (Not used in this set)
210	RGB_SEL/DSEL	O	Video output select signal output (Not used in this set)
211	TRG_SW	I	Not used. (Pull up)
212	DVDD18	—	Power supply (+3.3V)
213	FS_Bit0	O	FS Bit0 signal output
214	2ch/MULTI	I	2ch/MULTI exchange
215	SPDIF	O	Not used. (Open)
216	APLLVDD3	—	Power supply (+3.3V)
217	APLLCAP	—	Ext capacitor connected terminal

Pin No.	Pin Name	I/O	Description
218	APLLVSS	—	Ground
219	ADACVSS2	—	Ground
220	ADACVSS1	—	Ground
221	DIR_CE	O	DIR I/F chip select signal output
222	ASDATA3	O	Audio digital signal output to S-AIR transmitter (Not used in this set)
223	ASDATA2	O	Audio digital signal output to D-AMP
224	AVCM	—	Ext capacitor connected terminal
225	ASDATA1	O	Audio digital signal output to D-AMP
226	ASDATA0	O	Audio digital signal output to D-AMP
227	DIR_CL	O	DIR I/F clock output
228	ADACVDD1	—	Power supply (+3.3V)
229	ADACVDD2	—	Power supply (+3.3V)
230	Rt/DIR_DI	O	DIR I/F data output
231	Lt/DIR_DO	I	DIR I/F data input
232	ADACVSS3	—	Ground
233	ADACVDD3	—	Power supply (+3.3V)
234	SADCVDD18	—	Power supply (+1.8V)
235	SADCVSS18	—	Ground
236	RFGND18	—	Ground
237	RFVDD18	—	Power supply (+1.8V)
238	XTALO	O	Crystal output for main clock (27MHz)
239	XTALI	I	Crystal input for main clock (27MHz)
240	JITFO	O	The output terminal of RF jitter meter
241	JITFN	I	The input terminal of RF jitter meter
242	PLLVSS	—	Ground
243	PLLVDD3	—	Power supply (+3.3V)
244	LPFON	O	The negative output of loop filter amplifier
245	LPFIP	I	The positive input terminal of loop filter amplifier
246	LPFIN	I	The negative input terminal of loop filter amplifier
247	LPFOP	O	The positive output of loop filter amplifier
248	ADCVDD3	—	Power supply (+3.3V)
249	ADCVSS	—	Ground
250	RFVDD3	—	Power supply (+3.3V)
251	RFRPDC	O	RF ripple detect output
252	RFRPAC	I	RF ripple detect input (through AC-coupling)
253	HRFZC	I	High frequency RF ripple zero crossing
254	CRTPLP	O	Defect level filter capacitor connected terminal
255	RFGND18	—	Power supply (+3.3V)
256	OSP	O	RF offset cancellation capacitor connecting terminal

HBD-DZ340M/DZ640M/DZ840K/DZ840M/DZ940K

MAIN BOARD (5/9) IC5002 R5F3650KBDA (SYSTEM CONTROL)

Pin No.	Pin Name	I/O	Description
1	NO USE	—	Not used. (Open)
2	NO USE	—	Not used. (Open)
3	FL_CS	O	FL driver chip select signal output
4	SIRCS_IN	I	Sircs signal input
5	FL_D_OUT	O	FL and LED driver data output
6	NO USE	—	Not used. (Open)
7	FL_CLK	O	FL and LED driver clock output
8	BYTE	I	External data bus input. (Connected to ground)
9	CNVSS	I	Change processor mode input
10	NO USE	—	Not used. (Open)
11	NO USE	—	Not used. (Open)
12	RESET	I	System reset signal input
13	XOUT	O	Crystal output for main clock (8MHz)
14	VSS	—	Ground
15	XIN	I	Crystal input for main clock (8MHz)
16	VCC	—	Power supply (BUP +3.3V)
17	CEC_TX_RX	I/O	CEC data input/output
18	FS_Bit0	I	FS Bit0 signal input
19	FS_Bit1	I	FS Bit1 signal input
20	AC_CUT	I	AC-CUT detect signal input
21	NO USE	—	Not used. (Open)
22	NO USE	—	Not used. (Open)
23	NO USE	—	Not used. (Open)
24	NO USE	—	Not used. (Open)
25	NO USE	—	Not used. (Open)
26	NO USE	—	Not used. (Open)
27	S-AIR_RST (SPC_RST)	O	Not used. (Open)
28	LED_PWM	O	LED drive PWM signal output for illumination
29	S-AIR_SCL	I/O	S-AIR serial clock input/output (Not used in this set)
30	S-AIR_SDA	I/O	S-AIR serial data input/output (Not used in this set)
31	I2C_DATA/TXD1	I/O	I2C data (debug) and Flash Write TXD data input/output
32	I2C_CLK/RXD1	I/O	I2C clock (debug) and Flash Write RXD data input/output
33	ON CHIP DEBUG/ CLK1	O	Flash Write CLK signal output
34	RST1	O	Flash Write RST signal output
35	DVD_SID	O	Media serial data output
36	DVD_SOD	I	Media serial data input
37	DVD_SCD	I	Media chip select signal input
38	GPIO2	—	Not used.
39	P_CONT1	O	Power control signal output
40	S_AIR_DET	—	Not used.
41	P_CONT_FL	O	Power control signal output
42	DC_CONT	O	A.CAL MIC DC control signal output (Not used in this set)
43	NO USE	—	Not used. (Open)
44	CDM_OPEN_SW	I	CDM open switch signal input
45	MTK_RST	O	Reset signal output to CDX9917R or CDX9927R
46	CE	I	Flash Write CE signal input (Not used (Pll up))
47	I2C_DATA_PAO	I/O	TAS3308 serial data input/output
48	I2C_CLK_PAO	I/O	TAS3308 serial clock input/output
49	NO USE	I	Not used. (Open)
50	DVD_XIFBUSY	O	Busy request signal output to CDX9927R
51	DVD_XIFCS	I	Chip select signal input
52	GAIN_CONT	O	Not used. (Open)
53	KARAOKE_MODE	I	KARAOKE mode information signal input.
54	DRIVER_RST(EN)	O	D-AMP driver reset signal output
55	NO USE	I	Not used. (Open)
56	NO USE	I	Not used. (Open)
57	DAMP_INIT	O	D-AMP processor reset signal output

Pin No.	Pin Name	I/O	Description
58	DAMP_MUTE	O	D-AMP processor soft muting signal output
59	NO USE	—	Not used. (Open)
60	NO USE	—	Not used. (Open)
61	NO USE	—	Not used. (Open)
62	VCC2	—	Power supply (BUP+3.3V)
63	RDS	I	RDS data detect signal input (Not used in this set)
64	VSS	—	Ground
65	PLUG_DET	I	MIC insert detect signal input
66	DC_DET	I	Speaker DC balance protect signal input
67	SD/PVDD_DET	I	D-AMP driver shut down signal and PVDD detect signal input
68	A.CAL_OUT_LEVEL	I	Speaker output detect signal input for audio calibration (Not used in this set)
69	NO USE	—	(Not used)
70	NO USE	—	(Not used)
71	NO USE	—	Not used. (Open)
72	MIC_DET_OUT	—	Not used.
73	TAS_GPI01	I	General Purpose signal input
74	KEY_INT	I	Key wakeup signal input
75	2ch/Multi	I	2ch/Multi exchange signal input
76	ST_CE	—	Not used. (Open)
77	I2C_DATA_TUNER	O	TUNER serial data output
78	I2C_CLK_TUNER	I	TUNER serial data input
79	ST_CLK	—	Not used. (Open)
80	TUNED	—	Not used. (Open)
81	V_SEL0	O	Video select signal output
82	V_SEL1	—	Not used. (Open)
83	TV_SEL	—	Not used. (Open)
84	NO USE	—	Not used. (Open)
85	NO USE	—	Not used. (Open)
86	NO USE	—	Not used. (Open)
87	NO USE	—	Not used. (Open)
88	NO USE	—	Not used. (Open)
89	NO USE	—	Not used. (Open)
90	PULG DET2 (DH)/ MONO_ST_DET(D)	I	AUDIO IN insert detect signal input
91	A.SA2	I	EMS select (Not used in this set)
92	DESTINATION	I	Destination select input
93	MODEL	I	Model select input
94	KEY2	I	Key 2 input
95	KEY1	I	Key 1 input
96	VSS	—	Ground
97	KEY0	I	Key 0 input
98	Vref	—	Reference voltage (3.3V)
99	VCC	—	Power supply (+3.3V)
100	NO USE	I	Not used. (Open)

MAIN BOARD (6/9) IC6001 CS8422 (DIR)

Pin No.	Pin Name	I/O	Description
1	RX0/RXP0	I	SPDIF signal input
2	RX1/RXP0	I	SPDIF signal input
3	VA	I	Analog power input
4	AGND	—	Ground
5	RX2/RXP1	—	Not used
6	RX3/RXP1	—	Not used
7	AD0/CS	I	Address bit0/Chip select signal input
8	AD1/CDIN	I	Serial data input
9	SCL/CCLK	I	Serial clock input
10	SDA/CDOUT	O	Serial data output
11	XTI	I	Crystal oscillator input (24.576MHz)
12	XTO	O	Crystal oscillator output (24.576MHz)
13	ILRCK	—	Not used
14	ISCLK	—	Not used
15	SDIN	—	Not used
16	GPO0	O	DIR AUDIO signal output
17	GPO1	—	Not used
18	GPO2	—	Not used
19	V_REG	I	Voltage regulator input
20	VD_FILT	O	Digital voltage regulator output
21	DGND	—	Ground
22	VL	I	Logic power input
23	SDOUT2	O	Serial audio data output Not used
24	OSCLK2	O	Serial audio bit clock output Not used
25	OLRCK2	O	Serial audio left/right clock output Not used
26	TDM_IN	—	Not used
27	SDOUT1	O	Serial audio data output
28	OSCLK1	O	Serial audio bit clock output
29	OLRCK1	O	Serial audio left/right clock output
30	GPO3	O	DIR ERROR signal output
31	RMCK	O	Recovered master clock output
32	RST	I	Reset signal input

MAIN BOARD (8/9) IC3001 CXD9926ATQ (S-MASTER PROCESSOR, A/D CONVERTER, INPUT SELECT)

Pin No.	Pin Name	I/O	Description
1	DVDD_PWM2	—	Power supply terminal (+3.3V)
2, 3	PWM2_RD, PWM2_RI	O	Digital audio signal output terminal
4, 5	PWM3_LD, PWM3_LI	O	Digital audio (R-ch) signal output to the digital power amplifier
6	DVSS_PWM3	—	Ground
7	DVDD_PWM3	—	Power supply (+3.3V)
8, 9	PWM3_RD, PWM3_RI	O	Digital audio (L-ch) signal output to the digital power amplifier
10	VALID/SYNC	O	Valid signal output to the system controller Not used
11	DVDD2	—	Power supply (+3.3V)
12	DVSS2	—	Ground
13	XVREG_EN	I	Voltage regulator enable signal input terminal "L": regulator on Fixed at "L" in this set
14	STEST	I	Test terminal
15	MCLKOUT	O	Master clock signal output Not used
16	LRCLKOUT	O	L/R sampling clock signal Not used
17	SCLKOUT	O	Bit clock signal output Not used
18	SDOUT1	O	Serial audio data output Not used
19	SDOUT2/SPDIF_OUT	O	Serial audio data or SPDIF signal output
20	SPDIF_IN	I	SPDIF signal input terminal Not used
21 to 23	SDIN3 to SDIN1	I	Serial audio data input
24	LRCLKIN	I	L/R sampling clock signal input
25	SCLKIN	I	Bit clock signal input
26	MCLKIN	I	Master clock signal input
27	DVSS_DPLL	—	Ground
28	VR_DIG2	—	External capacitor connection terminal for internal +1.8V regulator
29	DVDD3	—	Power supply (+3.3V)
30	DVSS3	—	Ground
31	I2C_SDA2	I/O	Two-way I2C data bus input/output Not used
32	I2C_SCL2	I	I2C clock signal input Not used
33	I2C_SDA1	I/O	Two-way I2C data bus with the system controller
34	I2C_SCL1	I	I2C clock signal input from the system controller
35	CS	I	Chip select signal input Not used
36, 37	GPIO1, GPIO2	I/O	Not used
38	/MUTE	I	Muting on/off control signal input from the system controller "L": muting on
39	/RESET	I	Reset signal input from the system controller "L": reset
40	DVSS4	—	Ground
41	VR_DIG3	—	External capacitor connection terminal for internal +1.8V regulator
42	DVDD4	—	Power supply (+3.3V)
43	LINEIN1L	I	Analog audio (L-ch) signal input
44	LINEIN1R	I	Analog audio (R-ch) signal input
45	AVSSL1	—	Ground terminal
46	LINEIN2L	I	Analog audio (L-ch) signal input
47	LINEIN2R	I	Analog audio (R-ch) signal input
48	AVDD_LI1	—	Power supply (+3.3V)
49	LINEIN3L	I	Analog audio (L-ch) signal input Not used
50	LINEIN3R	I	Analog audio (R-ch) signal input Not used
51	LINEIN4L	I	Analog audio (L-ch) signal input Not used
52	LINEIN4R	I	Analog audio (R-ch) signal input Not used
53	AVDD_LI2	—	Power supply (+3.3V)
54	LINEIN5L	I	Analog audio (L-ch) signal input Not used
55	LINEIN5R	I	Analog audio (R-ch) signal input Not used
56	AVSS_LI2	—	Ground
57	LINEIN6L	I	Analog audio (L-ch) signal input
58	LINEIN6R	I	Analog audio (R-ch) signal input
59	AVSS_ADC/REF	—	Ground terminal
60	LINEIN7L	I	Analog audio (L-ch) signal input Not used
61	LINEIN7R	I	Analog audio (R-ch) signal input Not used
62	AVDD_ADC	—	Power supply terminal (+3.3V)
63	LINEIN8L	I	Analog audio (L-ch) signal input Not used

Pin No.	Pin Name	I/O	Description
64	LINEIN8R	I	Analog audio (R-ch) signal input Not used
65	AVDD_LI3	—	Power supply terminal (+3.3V)
66	LINEIN9L	I	Analog audio (L-ch) signal input Not used
67	LINEIN9R	I	Analog audio (R-ch) signal input Not used
68	AVSS_LI2	—	Ground
69	LINEIN10L	I	Analog audio (L-ch) signal input
70	LINEIN10R	I	Analog audio (R-ch) signal input
71	BIAS_REF	O	Bias output terminal
72	BG_REF	O	Band gap output
73	V1P5_REF	O	Common mode output
74	AVDD_REF	—	Power supply (+3.3V)
75	AVDD_LO	—	Power supply (+3.3V)
76	LINEOUT1L	O	Analog audio (L-ch) signal output Not used
77	LINEOUT1R	O	Analog audio (R-ch) signal output Not used
78	AVSS_LO	—	Ground
79	AVDD_PLL	—	Power supply (+3.3V)
80, 81	PLL_FLTP, PLL_FLTM	—	PLL filter terminal
82	AVSS_PLL	—	Ground
83	VR_ANA2	—	External capacitor connection terminal for internal +1.8V regulator
84	AVDD_OSC	—	Power supply (+3.3V)
85	XTAL_IN	I	System clock input (24.576 MHz)
86	XTAL_OUT	O	System clock output (24.576 MHz)
87	AVSS_OSC	—	Ground
88	VR_ANA	—	External capacitor connection terminal for internal +1.8V regulator
89	DVDD1	—	Power supply (+3.3V)
90	DVSS1	—	Ground
91	VR_DIG1	—	External capacitor connection terminal for internal +1.8V regulator
92, 93	PWM1_LD, PWM1_LI	O	Digital audio (R-ch) signal output
94	DVSS_PWM1	—	Ground
95	DVDD_PWM1	—	Power supply (+3.3V)
96, 97	PWM1_RD, PWM1_RI	O	Digital audio (L-ch) signal output
98, 99	PWM2_LD, PWM2_LI	O	Digital audio signal output
100	DVSS_PWM2	—	Ground

6-2. FRONT PANEL SECTION

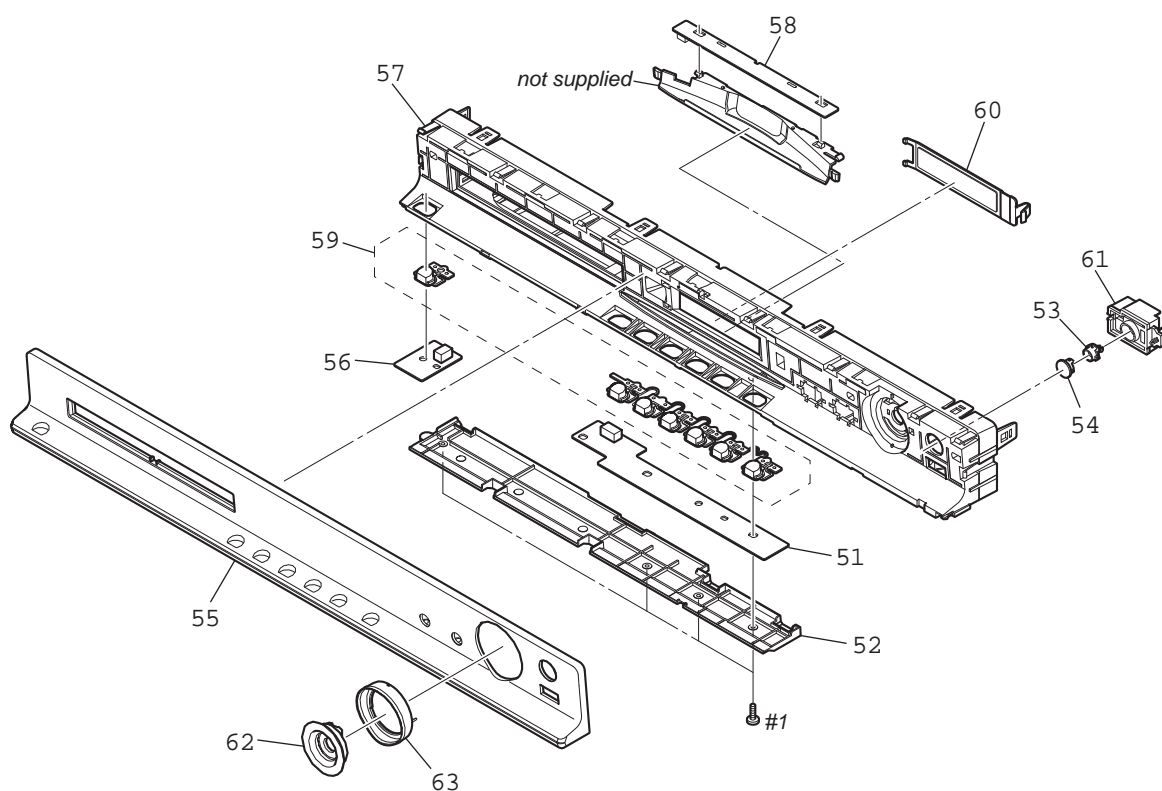

Ref. No.	Part No.	Description	Remark
51	A-1804-422-A	KEY BOARD, COMPLETE	
52	4-267-082-01	COVER (DH), BOTTOM	
53	4-267-087-01	BUTTON (USB), SPACER	
54	4-267-086-01	BUTTON (USB), TOP	
55	4-267-079-11	WINDOW (DH-1) (DZ340M)	
55	4-267-079-41	WINDOW (DH-1) (DZ640M)	
55	4-267-079-61	WINDOW (DH-1) (DZ840M)	
55	4-267-079-71	WINDOW (DH-1) (DZ840K)	
55	4-267-079-81	WINDOW (DH-1) (DZ940K)	
56	A-1804-423-A	POWER KEY BOARD, COMPLETE	
57	4-267-081-01	PANEL (DH), BASE (DZ340M/DZ640M/DZ840K/DZ840M)	

Ref. No.	Part No.	Description	Remark
57	4-267-081-11	PANEL (DH), BASE (DZ940K)	
58	A-1804-424-A	LED BOARD, COMPLETE (DZ640M/DZ840K/DZ840M/DZ940K)	
59	4-267-085-01	BUTTON (FUNCTION)	
60	4-267-093-01	FILTER (DH), COLOR	
61	4-267-088-01	BUTTON (USB), BASE	
62	4-267-092-01	INDICATOR (RING) (DZ940K)	
63	4-267-084-01	RING (VOL) (DZ940K)	
#1	7-685-504-19	SCREW +BTP 2X6 TYPE2 N-S	

6-3. FRONT BOARDS SECTION

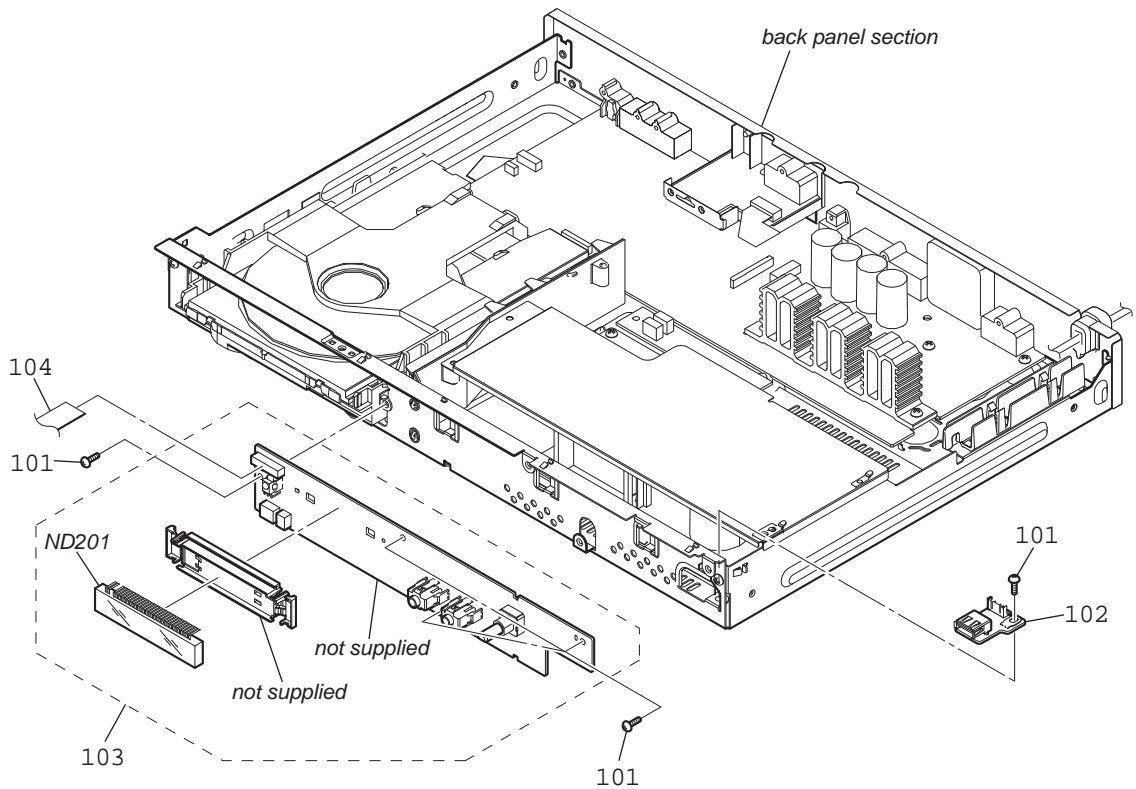

Note: If the wire (flat type) was replaced, fold it some as the wire (flat type) before replacement.

Ref. No.	Part No.	Description	Remark	Ref. No.	Part No.	Description	Remark
101	3-077-331-21	+BV3 (3-CR)		103	A-1804-407-A	PANEL BOARD, COMPLETE (DZ640M/DZ840M)	
102	A-1804-412-A	USB BOARD, COMPLETE		103	A-1804-408-A	PANEL BOARD, COMPLETE (DZ940K)	
103	A-1804-404-A	PANEL BOARD, COMPLETE (DZ340M)		104	1-835-400-21	CABLE, FLEXIBLE FLAT (15 CORE)	
103	A-1804-405-A	PANEL BOARD, COMPLETE (DZ840K)		ND201	1-483-358-11	VACUUM FLUORESCENT DISPLAY	

6-4. BACK PANEL SECTION

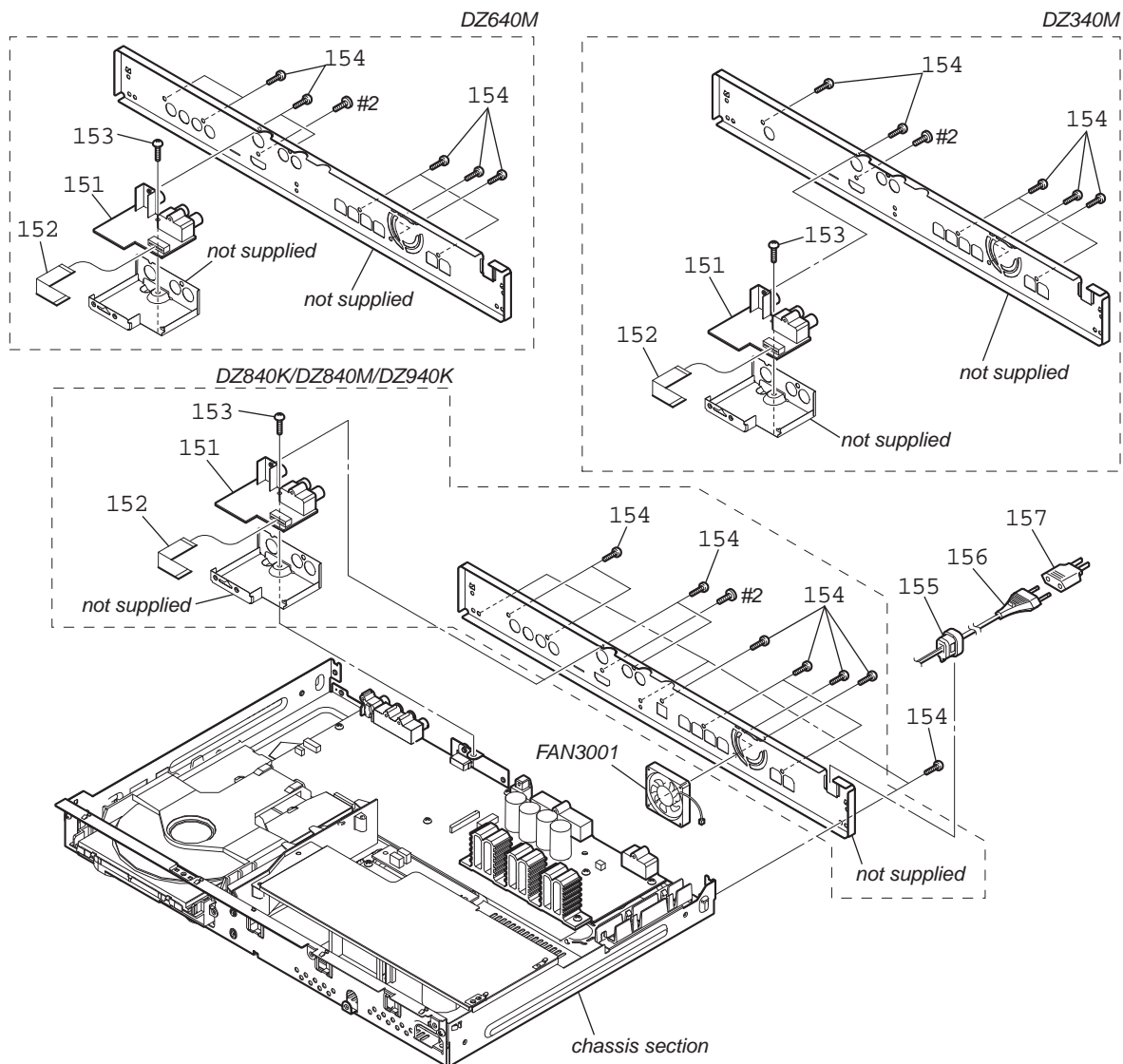

Note: If the wire (flat type) was replaced, fold it some as the wire (flat type) before replacement.

Ref. No.	Part No.	Description	Remark	Ref. No.	Part No.	Description	Remark
151	A-1831-271-A	IO BOARD, COMPLETE		△ 156	1-834-966-41	CORD, POWER-SUPPLY (RU, AEP, E3, E15, PH, SP)	
152	1-832-572-21	CABLE, FLEXIBLE FLAT (13 CORE)		△ 156	1-837-309-21	CORD, POWER-SUPPLY (EA)	
153	3-077-331-21	+BV3 (3-CR)		△ 156	1-839-012-11	CORD, POWER-SUPPLY (E12)	
154	3-077-331-01	+BV3 (3-CR)		△ 157	1-569-008-33	ADAPTOR, CONVERSION (PH)	
155	3-703-244-21	BUSHING, CORD (2104) (EXCEPT TH)		FAN3001	1-855-048-11	DC FAN (40mm)	
155	4-916-783-01	BUSHING, CORD (TH)		#2	7-682-547-04	SCREW +B 3X6	
△ 156	1-834-288-12	CORD, POWER (TH)					

6-5. CHASSIS SECTION

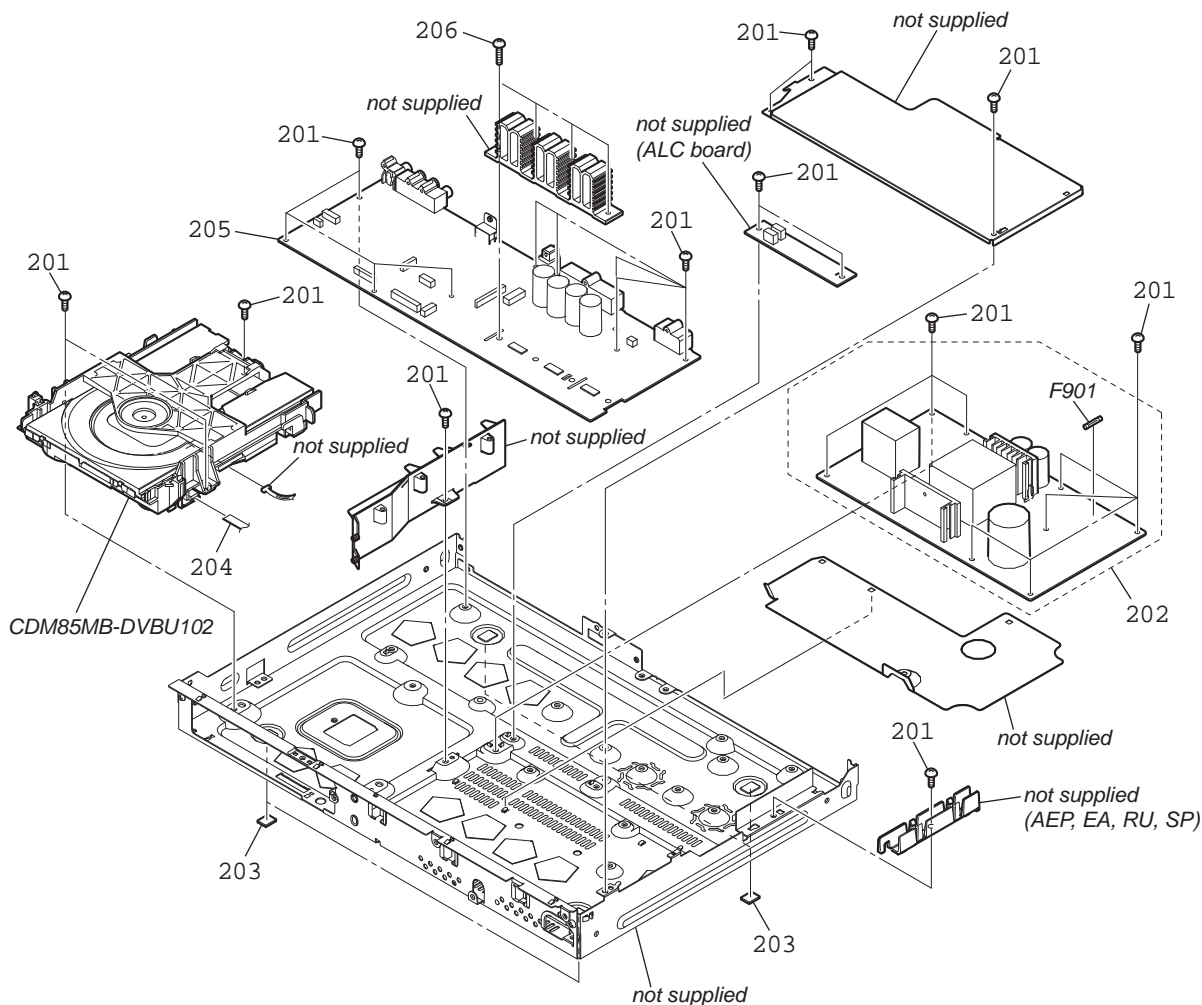

Note: If the wire (flat type) was replaced, fold it some as the wire (flat type) before replacement.

Ref. No.	Part No.	Description	Remark	Ref. No.	Part No.	Description	Remark
201	3-077-331-21	+BV3 (3-CR)		205	A-1804-498-A	MAIN BOARD, COMPLETE (for SERVICE)	(DZ840K: EA)
202	A-1804-587-A	POWER BOARD, COMPLETE		205	A-1804-499-A	MAIN BOARD, COMPLETE (for SERVICE)	(DZ840K: SP)
202	A-1804-588-A	POWER BOARD, COMPLETE (PH, SP, TH)		205	A-1804-500-A	MAIN BOARD, COMPLETE (for SERVICE)	(DZ840K: PH, TH)
202	A-1804-589-A	POWER BOARD, COMPLETE (AEP, EA)		205	A-1804-501-A	MAIN BOARD, COMPLETE (for SERVICE)	(DZ940K: E3)
202	A-1804-592-A	POWER BOARD, COMPLETE (E3, E12, E15)		205	A-1804-502-A	MAIN BOARD, COMPLETE (for SERVICE)	(DZ940K: E15)
203	4-151-413-01	CUSHION (EGD)		205	A-1804-503-A	MAIN BOARD, COMPLETE (for SERVICE)	(DZ940K: EA)
204	1-832-539-21	CABLE, FLEXIBLE FLAT (5 CORE)		205	A-1804-504-A	MAIN BOARD, COMPLETE (for SERVICE)	(DZ940K: SP)
205	A-1804-471-A	MAIN BOARD, COMPLETE (for SERVICE)	(DZ340M)	205	A-1830-190-A	MAIN BOARD, COMPLETE (for SERVICE)	(DZ840K: AEP)
205	A-1804-483-A	MAIN BOARD, COMPLETE (for SERVICE)	(DZ640M)	205	A-1830-195-A	MAIN BOARD, COMPLETE (for SERVICE)	(DZ940K: AEP)
205	A-1804-494-A	MAIN BOARD, COMPLETE (for SERVICE)	(DZ840M)	206	3-077-331-11	+BV3 (3-CR)	
205	A-1804-495-A	MAIN BOARD, COMPLETE (for SERVICE)	(DZ840K: E12)	F901	1-523-067-51	FUSE (T5AH/250V)	
205	A-1804-496-A	MAIN BOARD, COMPLETE (for SERVICE)	(DZ840K: E3)				
205	A-1804-497-A	MAIN BOARD, COMPLETE (for SERVICE)	(DZ840K: E15)				

6-6. DVD MECHANISM DECK SECTION
(CDM85MB-DVBU102)

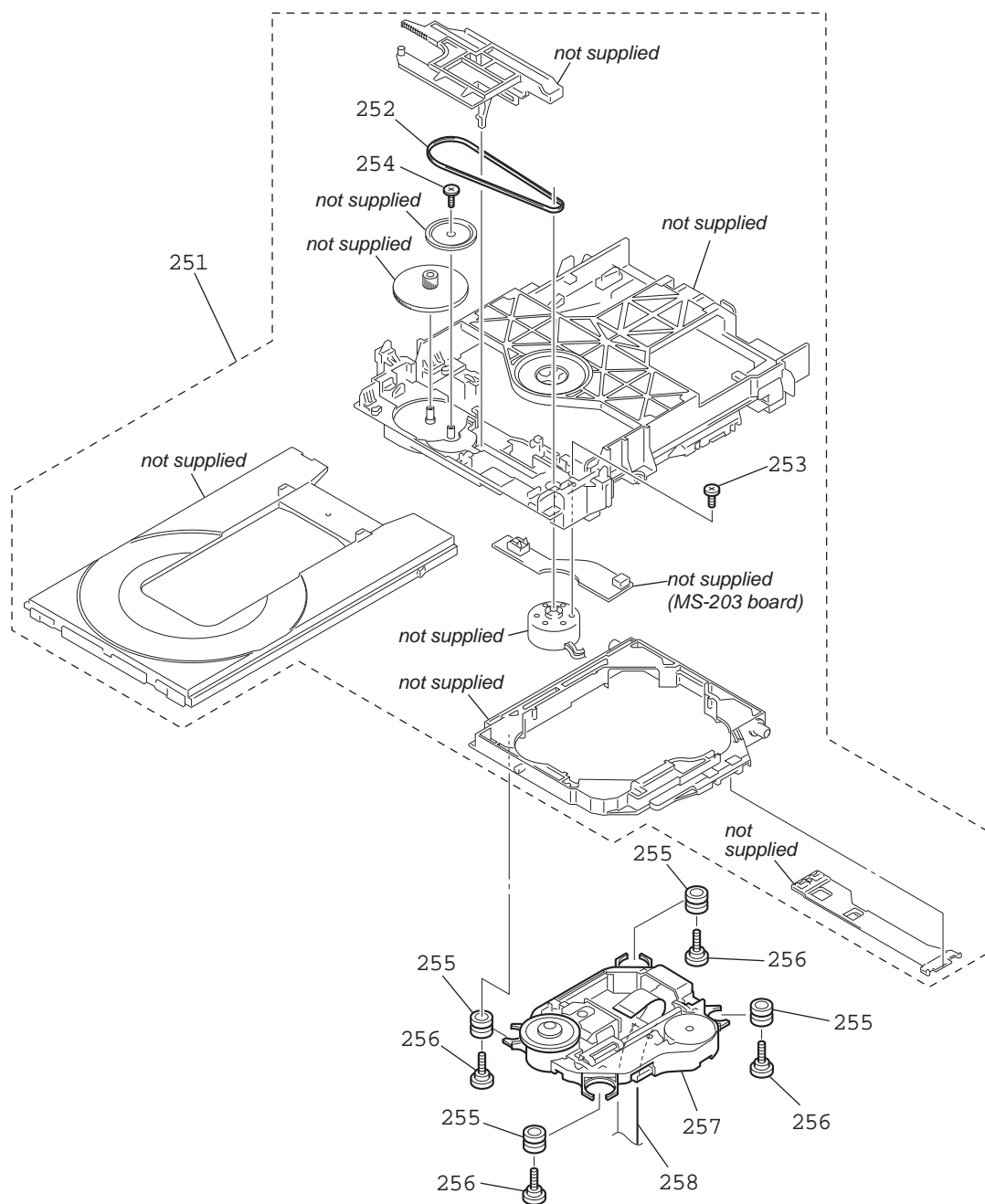

Note: If the wire (flat type) was replaced, fold it some as the wire (flat type) before replacement.

Ref. No.	Part No.	Description	Remark	Ref. No.	Part No.	Description	Remark
251	A-1749-923-A	CDM85 (MB) ASSY		255	2-634-618-01	INSULATOR	
252	3-088-371-01	BELT		256	3-087-599-01	SCREW, INSULATOR	
253	4-974-725-11	SCREW (M1.7X2.5), P		△ 257	8-820-321-12	OPTICAL PICK-UP (KHM313CAA/C2RP1)	
254	4-674-137-11	SCREW (PTP2X5)		258	1-838-443-11	FLEXIBLE FLAT CABLE 24P	

HBD-DZ340M/DZ640M/DZ840K/DZ840M/DZ940K

SECTION 7

ELECTRICAL PARTS LIST

ALC IO

Note:

- Due to standardization, replacements in the parts list may be different from the parts specified in the diagrams or the components used on the set.
- -XX and -X mean standardized parts, so they may have some difference from the original one.
- Items marked "*" are not stocked since they are seldom required for routine service. Some delay should be anticipated when ordering these items.
- RESISTORS
All resistors are in ohms.
METAL: Metal-film resistor.
METAL OXIDE: Metal oxide-film resistor.
F: nonflammable

- CAPACITORS
uF: μ F
uH: μ H
- COILS
uH: μ H
- SEMICONDUCTORS
In each case, u: μ , for example:
uA. . : μ A. . , uPA. . , μ PA. . ,
uPB. . : μ PB. . , uPC. . , μ PC. . ,
uPD. . : μ PD. .
- Abbreviation
E3 : 240V AC area in E model
E12 : 220 – 240V AC area in E model
E15 : Iranian model
EA : Saudi Arabia model
PH : Philippines model
RU : Russian model

When indicating parts by reference number, please include the board name.

The components identified by mark \triangle or dotted line with mark \triangle are critical for safety.
Replace only with part number specified.

The components identified by mark \square contain confidential information.
Strictly follow the instructions whenever the components are repaired and/or replaced.

SP : Singapore model
TH : Thai model

Ref. No.	Part No.	Description	Remark	Ref. No.	Part No.	Description	Remark
		ALC BOARD (DZ340M/DZ640M/DZ840M)		C111	1-165-908-11	CERAMIC CHIP 1uF 10%	10V
		*****		C123	1-162-966-11	CERAMIC CHIP 0.0022uF 10%	50V
		< CAPACITOR >		C125	1-162-927-11	CERAMIC CHIP 100PF 5%	50V
				C132	1-162-927-11	CERAMIC CHIP 100PF 5%	50V
				C135	1-126-964-11	ELECT 10uF 20%	50V
C701	1-112-780-11	CERAMIC CHIP 0.47uF 10%	16V				
C702	1-162-923-11	CERAMIC CHIP 47PF 5%	50V	C138	1-126-964-11	ELECT 10uF 20%	50V
C703	1-126-964-11	ELECT 10uF 20%	50V	C141	1-100-909-11	CERAMIC CHIP 10uF 10%	6.3V
* C704	1-112-298-91	CERAMIC CHIP 1uF 10%	16V	C142	1-100-909-11	CERAMIC CHIP 10uF 10%	6.3V
* C705	1-112-298-91	CERAMIC CHIP 1uF 10%	16V			< CONNECTOR >	
C706	1-126-963-11	ELECT 4.7uF 20%	50V	CN103	1-779-550-21	CONNECTOR, FFC (LIF (NON-ZIF)) 13P	
C708	1-126-964-11	ELECT 10uF 20%	50V	CN106	1-842-376-11	CONNECTOR, FM ANTENNA 2P	(ANTENNA COAXIAL 75Ω FM)
C709	1-114-325-11	CERAMIC CHIP 0.1uF 10%	25V			< DIODE >	
C711	1-126-933-11	ELECT 100uF 20%	16V				
C712	1-114-325-11	CERAMIC CHIP 0.1uF 10%	25V	D101	6-501-579-01	DIODE MC2837	
						< FERRITE BEAD >	
C713	1-126-963-11	ELECT 4.7uF 20%	50V				
		< CONNECTOR >		FB101	1-400-177-21	INDUCTOR, EMI FERRITE (1608)	
CN701	1-564-706-11	PIN, CONNECTOR (SMALL TYPE) 4P				< BPF >	
		< IC >		FL101	1-236-711-21	FILTER, BAND PASS	
IC701	6-713-989-01	IC NJM2783V(TE2)				< IC >	
		< RESISTOR >		IC101	6-717-231-01	IC RZ5B700-0001E2	
				IC103	6-715-134-01	IC MM3404A33URE	
R701	1-216-817-11	METAL CHIP 470 5%	1/10W			< JACK >	
R702	1-216-845-11	METAL CHIP 100K 5%	1/10W	J102	1-821-886-11	JACK, PIN 2P (TV AUDIO IN)	
R703	1-216-833-11	METAL CHIP 10K 5%	1/10W			< COIL >	
R704	1-216-821-11	METAL CHIP 1K 5%	1/10W				
R705	1-216-853-11	METAL CHIP 470K 5%	1/10W	L101	1-481-813-21	INDUCTOR 1uH	
						< RESISTOR >	
R706	1-216-833-11	METAL CHIP 10K 5%	1/10W	R101	1-216-833-11	METAL CHIP 10K 5%	1/10W
R707	1-216-835-11	METAL CHIP 15K 5%	1/10W	R102	1-216-809-11	METAL CHIP 100 5%	1/10W
R708	1-216-864-11	SHORT CHIP 0		R103	1-216-809-11	METAL CHIP 100 5%	1/10W
R710	1-216-864-11	SHORT CHIP 0		R104	1-216-864-11	SHORT CHIP 0	
		*****		R105	1-216-864-11	SHORT CHIP 0	
	A-1831-271-A	IO BOARD, COMPLETE		R106	1-216-821-11	METAL CHIP 1K 5%	1/10W
		*****		R122	1-218-895-11	METAL CHIP 100K 0.5%	1/10W
		< CAPACITOR >		R128	1-216-845-11	METAL CHIP 100K 5%	1/10W
				R131	1-216-821-11	METAL CHIP 1K 5%	1/10W
C101	1-114-325-11	CERAMIC CHIP 0.1uF 10%	25V	R132	1-216-845-11	METAL CHIP 100K 5%	1/10W
C103	1-165-908-11	CERAMIC CHIP 1uF 10%	10V				
C106	1-165-908-11	CERAMIC CHIP 1uF 10%	10V				
C107	1-114-146-91	CERAMIC CHIP 0.047uF 10%	25V				
C108	1-164-315-11	CERAMIC CHIP 470PF 5%	50V				
C109	1-165-908-11	CERAMIC CHIP 1uF 10%	10V				
C110	1-126-933-11	ELECT 100uF 20%	16V				

HBD-DZ340M/DZ640M/DZ840K/DZ840M/DZ940K

IO KEY LED MAIN

Ref. No.	Part No.	Description	Remark
R137	1-216-821-11	METAL CHIP 1K 5%	1/10W
< VIBRATOR >			
X101	1-767-317-11	VIBRATOR, CRYSTAL (32.768kHz)	

A-1804-422-A	KEY BOARD, COMPLETE *****		
< CONNECTOR >			
CN501	1-580-789-21	PIN, CONNECTOR (SMD) 6P	
< RESISTOR >			
R501	1-216-821-11	METAL CHIP 1K 5%	1/10W
R502	1-216-825-11	METAL CHIP 2.2K 5%	1/10W
R503	1-216-825-11	METAL CHIP 2.2K 5%	1/10W
R504	1-216-809-11	METAL CHIP 100 5%	1/10W
R505	1-216-809-11	METAL CHIP 100 5%	1/10W
R506	1-216-821-11	METAL CHIP 1K 5%	1/10W
< SWITCH >			
S501	1-798-284-11	SWITCH, TACTILE (■)	
S502	1-798-284-11	SWITCH, TACTILE (◀◀)	
S503	1-798-284-11	SWITCH, TACTILE (▶▶)	
S504	1-798-284-11	SWITCH, TACTILE (FUNCTION)	
S505	1-798-284-11	SWITCH, TACTILE (▲)	
S506	1-798-284-11	SWITCH, TACTILE (▶)	

A-1804-424-A	LED BOARD, COMPLETE (DZ640M/DZ840K/DZ840M/DZ940K) *****		
< CAPACITOR >			
C601	1-114-325-11	CERAMIC CHIP 0.1uF 10%	25V
C602	1-114-325-11	CERAMIC CHIP 0.1uF 10%	25V
< CONNECTOR >			
* CN601	1-580-055-21	PIN, CONNECTOR (SMD) 2P	
< DIODE >			
D601	6-502-395-01	LED SL-194S-WS-SD-T (FRONT PANEL ILLUMINATION)	
D602	6-502-395-01	LED SL-194S-WS-SD-T (FRONT PANEL ILLUMINATION)	
< RESISTOR >			
R601	1-216-817-11	METAL CHIP 470 5%	1/10W
R602	1-216-817-11	METAL CHIP 470 5%	1/10W
R604	1-216-817-11	METAL CHIP 470 5%	1/10W
R605	1-216-817-11	METAL CHIP 470 5%	1/10W

Ref. No.	Part No.	Description	Remark
Ⓔ	A-1804-471-A	MAIN BOARD, COMPLETE (for SERVICE)	(DZ340M)
Ⓔ	A-1804-483-A	MAIN BOARD, COMPLETE (for SERVICE)	(DZ640M)
Ⓔ	A-1804-494-A	MAIN BOARD, COMPLETE (for SERVICE)	(DZ840M)
Ⓔ	A-1804-495-A	MAIN BOARD, COMPLETE (for SERVICE)	(DZ840K: E12)
Ⓔ	A-1804-496-A	MAIN BOARD, COMPLETE (for SERVICE)	(DZ840K: E3)
Ⓔ	A-1804-497-A	MAIN BOARD, COMPLETE (for SERVICE)	(DZ840K: E15)
Ⓔ	A-1804-498-A	MAIN BOARD, COMPLETE (for SERVICE)	(DZ840K: EA)
Ⓔ	A-1804-499-A	MAIN BOARD, COMPLETE (for SERVICE)	(DZ840K: SP)
Ⓔ	A-1804-500-A	MAIN BOARD, COMPLETE (for SERVICE)	(DZ840K: PH, TH)
Ⓔ	A-1804-501-A	MAIN BOARD, COMPLETE (for SERVICE)	(DZ940K: E3)
Ⓔ	A-1804-502-A	MAIN BOARD, COMPLETE (for SERVICE)	(DZ940K: E15)
Ⓔ	A-1804-503-A	MAIN BOARD, COMPLETE (for SERVICE)	(DZ940K: EA)
Ⓔ	A-1804-504-A	MAIN BOARD, COMPLETE (for SERVICE)	(DZ940K: SP)
Ⓔ	A-1830-190-A	MAIN BOARD, COMPLETE (for SERVICE)	(DZ840K: AEP)
Ⓔ	A-1830-195-A	MAIN BOARD, COMPLETE (for SERVICE)	(DZ940K: AEP)

< CAPACITOR >			
C1003	1-112-781-11	CERAMIC CHIP 1uF 10%	10V
C1004	1-114-130-11	CERAMIC CHIP 1uF 10%	6.3V
C1005	1-112-777-11	CERAMIC CHIP 0.01uF 10%	25V
C1006	1-114-325-11	CERAMIC CHIP 0.1uF 10%	25V
C1007	1-124-589-11	ELECT 47uF 20%	16V
C1008	1-114-130-11	CERAMIC CHIP 1uF 10%	6.3V
C1009	1-114-130-11	CERAMIC CHIP 1uF 10%	6.3V
C1101	1-112-777-11	CERAMIC CHIP 0.01uF 10%	25V
C1102	1-112-781-11	CERAMIC CHIP 1uF 10%	10V
C1105	1-126-947-11	ELECT 47uF 20%	35V
C1106	1-114-323-11	CERAMIC CHIP 0.01uF 10%	50V
C1108	1-114-325-11	CERAMIC CHIP 0.1uF 10%	25V
C1109	1-114-325-11	CERAMIC CHIP 0.1uF 10%	25V
C1110	1-100-916-11	CERAMIC CHIP 0.1uF 10%	16V
C1111	1-104-658-91	ELECT 100uF 20%	10V
C1112	1-126-947-11	ELECT 47uF 20%	35V
C1113	1-114-323-11	CERAMIC CHIP 0.01uF 10%	50V
C1114	1-114-325-11	CERAMIC CHIP 0.1uF 10%	25V
C1115	1-114-325-11	CERAMIC CHIP 0.1uF 10%	25V
C1116	1-114-325-11	CERAMIC CHIP 0.1uF 10%	25V
C1117	1-126-947-11	ELECT 47uF 20%	35V
C1118	1-126-947-11	ELECT 47uF 20%	35V
C1119	1-126-947-11	ELECT 47uF 20%	35V
C1120	1-114-130-11	CERAMIC CHIP 1uF 10%	6.3V
C1121	1-114-130-11	CERAMIC CHIP 1uF 10%	6.3V
C1122	1-114-130-11	CERAMIC CHIP 1uF 10%	6.3V
C1123	1-114-130-11	CERAMIC CHIP 1uF 10%	6.3V
C1124	1-114-130-11	CERAMIC CHIP 1uF 10%	6.3V
C1125	1-114-325-11	CERAMIC CHIP 0.1uF 10%	25V
C1126	1-114-325-11	CERAMIC CHIP 0.1uF 10%	25V

Ref. No.	Part No.	Description	Remark	Ref. No.	Part No.	Description	Remark
C1127	1-114-323-11	CERAMIC CHIP 0.01uF	10% 50V	C1510	1-100-916-11	CERAMIC CHIP 0.1uF	10% 16V
C1129	1-100-909-11	CERAMIC CHIP 10uF	10% 6.3V	C1511	1-100-916-11	CERAMIC CHIP 0.1uF	10% 16V
C1130	1-114-325-11	CERAMIC CHIP 0.1uF	10% 25V	C1512	1-100-916-11	CERAMIC CHIP 0.1uF	10% 16V
C1132	1-100-916-11	CERAMIC CHIP 0.1uF	10% 16V	C1513	1-100-916-11	CERAMIC CHIP 0.1uF	10% 16V
C1133	1-100-916-11	CERAMIC CHIP 0.1uF	10% 16V	C1514	1-126-964-11	ELECT 10uF	20% 50V
C1135	1-100-436-91	CERAMIC CHIP 0.033uF	10% 25V	C1516	1-162-964-11	CERAMIC CHIP 0.001uF	10% 50V
C1136	1-112-777-11	CERAMIC CHIP 0.01uF	10% 25V	C1518	1-114-325-11	CERAMIC CHIP 0.1uF	10% 25V
C1137	1-100-916-11	CERAMIC CHIP 0.1uF	10% 16V	C1520	1-126-935-11	ELECT 470uF	20% 16V
C1138	1-162-964-11	CERAMIC CHIP 0.001uF	10% 50V	C1522	1-164-730-11	CERAMIC CHIP 0.0012uF	10% 50V
C1139	1-164-858-11	CERAMIC CHIP 22PF	5% 50V	C1523	1-162-964-11	CERAMIC CHIP 0.001uF	10% 50V
C1140	1-114-325-11	CERAMIC CHIP 0.1uF	10% 25V	C1524	1-110-563-11	CERAMIC CHIP 0.068uF	10% 16V
C1144	1-114-323-11	CERAMIC CHIP 0.01uF	10% 50V	C1525	1-100-436-91	CERAMIC CHIP 0.033uF	10% 25V
C1145	1-126-964-11	ELECT 10uF	20% 50V	C1531	1-114-130-11	CERAMIC CHIP 1uF	10% 6.3V
C1146	1-114-325-11	CERAMIC CHIP 0.1uF	10% 25V	C1532	1-112-781-11	CERAMIC CHIP 1uF	10% 10V
C1147	1-112-779-11	CERAMIC CHIP 0.047uF	10% 25V	C1725	1-112-777-11	CERAMIC CHIP 0.01uF	10% 25V
C1148	1-112-779-11	CERAMIC CHIP 0.047uF	10% 25V	C1727	1-100-916-11	CERAMIC CHIP 0.1uF	10% 16V
C1149	1-114-325-11	CERAMIC CHIP 0.1uF	10% 25V	C1729	1-165-884-11	CERAMIC CHIP 2.2uF	10% 6.3V
C1151	1-162-964-11	CERAMIC CHIP 0.001uF	10% 50V	C1730	1-112-067-11	CERAMIC CHIP 0.22uF	10% 16V
C1152	1-164-856-81	CERAMIC CHIP 18PF	5% 50V	C1731	1-114-320-11	CERAMIC CHIP 0.22uF	10% 6.3V
C1153	1-164-852-11	CERAMIC CHIP 12PF	5% 50V	C1732	1-100-916-11	CERAMIC CHIP 0.1uF	10% 16V
C1154	1-114-325-11	CERAMIC CHIP 0.1uF	10% 25V	C1733	1-114-320-11	CERAMIC CHIP 0.22uF	10% 6.3V
C1155	1-114-323-11	CERAMIC CHIP 0.01uF	10% 50V	C1734	1-114-130-11	CERAMIC CHIP 1uF	10% 6.3V
C1156	1-114-323-11	CERAMIC CHIP 0.01uF	10% 50V	C1736	1-114-323-11	CERAMIC CHIP 0.01uF	10% 50V
C1158	1-114-323-11	CERAMIC CHIP 0.01uF	10% 50V	C1742	1-126-933-11	ELECT 100uF	20% 16V
C1159	1-114-325-11	CERAMIC CHIP 0.1uF	10% 25V	C1747	1-114-325-11	CERAMIC CHIP 0.1uF	10% 25V
C1160	1-114-323-11	CERAMIC CHIP 0.01uF	10% 50V	C1751	1-114-323-11	CERAMIC CHIP 0.01uF	10% 50V
C1161	1-114-323-11	CERAMIC CHIP 0.01uF	10% 50V	C1752	1-164-172-11	CERAMIC CHIP 0.0056uF	10% 25V
C1162	1-114-323-11	CERAMIC CHIP 0.01uF	10% 50V	C1753	1-114-323-11	CERAMIC CHIP 0.01uF	10% 50V
C1163	1-114-325-11	CERAMIC CHIP 0.1uF	10% 25V	C2108	1-112-746-11	CERAMIC CHIP 4.7uF	10% 6.3V
C1164	1-114-323-11	CERAMIC CHIP 0.01uF	10% 50V	C2109	1-126-933-11	ELECT 100uF	20% 16V
C1165	1-114-325-11	CERAMIC CHIP 0.1uF	10% 25V	C2112	1-126-923-91	ELECT 220uF	20% 10V
C1169	1-114-325-11	CERAMIC CHIP 0.1uF	10% 25V	C2118	1-114-325-11	CERAMIC CHIP 0.1uF	10% 25V
C1170	1-162-965-11	CERAMIC CHIP 0.0015uF	10% 50V	C2119	1-162-964-11	CERAMIC CHIP 0.001uF	10% 50V
C1171	1-114-325-11	CERAMIC CHIP 0.1uF	10% 25V	C2145	1-114-325-11	CERAMIC CHIP 0.1uF	10% 25V
C1172	1-114-325-11	CERAMIC CHIP 0.1uF	10% 25V	C2146	1-100-909-11	CERAMIC CHIP 10uF	10% 6.3V
C1174	1-114-323-11	CERAMIC CHIP 0.01uF	10% 50V	C2148	1-100-909-11	CERAMIC CHIP 10uF	10% 6.3V
C1175	1-114-323-11	CERAMIC CHIP 0.01uF	10% 50V	C2503	1-112-746-11	CERAMIC CHIP 4.7uF	10% 6.3V
C1176	1-114-323-11	CERAMIC CHIP 0.01uF	10% 50V	C3000	1-126-933-11	ELECT 100uF	20% 16V
C1177	1-124-635-00	ELECT 220uF	20% 6.3V	C3001	1-126-786-11	ELECT 47uF	20% 16V
C1179	1-114-325-11	CERAMIC CHIP 0.1uF	10% 25V	C3002	1-114-325-11	CERAMIC CHIP 0.1uF	10% 25V
C1180	1-114-325-11	CERAMIC CHIP 0.1uF	10% 25V	C3003	1-164-937-11	CERAMIC CHIP 0.001uF	10% 50V
C1181	1-114-325-11	CERAMIC CHIP 0.1uF	10% 25V	C3005	1-126-795-11	ELECT 10uF	20% 50V
C1182	1-114-130-11	CERAMIC CHIP 1uF	10% 6.3V	C3051	1-114-868-11	CERAMIC CHIP 0.1uF	10% 50V
C1183	1-114-130-11	CERAMIC CHIP 1uF	10% 6.3V	C3071	1-112-777-11	CERAMIC CHIP 0.01uF	10% 25V
C1186	1-114-130-11	CERAMIC CHIP 1uF	10% 6.3V	C3091	1-126-934-11	ELECT 220uF	20% 16V
C1187	1-126-947-11	ELECT 47uF	20% 35V	C3092	1-114-325-11	CERAMIC CHIP 0.1uF	10% 25V
C1190	1-126-382-11	ELECT 100uF	20% 16V	C3201	1-112-254-11	ELECT 1000uF	20% 35V
C1191	1-114-325-11	CERAMIC CHIP 0.1uF	10% 25V				(RU, PH, SP, TH)
C1193	1-114-130-11	CERAMIC CHIP 1uF	10% 6.3V	C3201	1-112-256-11	ELECT 1500uF	20% 35V
C1195	1-114-130-11	CERAMIC CHIP 1uF	10% 6.3V				(AEP, E3, E12, E15, EA)
C1197	1-114-325-11	CERAMIC CHIP 0.1uF	10% 25V	C3203	1-112-246-11	ELECT 100uF	20% 35V
C1198	1-114-130-11	CERAMIC CHIP 1uF	10% 6.3V	C3204	1-114-868-11	CERAMIC CHIP 0.1uF	10% 50V
C1199	1-114-322-11	CERAMIC CHIP 0.0047uF	10% 50V	C3205	1-114-325-11	CERAMIC CHIP 0.1uF	10% 25V
C1503	1-100-916-11	CERAMIC CHIP 0.1uF	10% 16V	C3210	1-100-916-11	CERAMIC CHIP 0.1uF	10% 16V
C1504	1-100-916-11	CERAMIC CHIP 0.1uF	10% 16V	C3211	1-100-916-11	CERAMIC CHIP 0.1uF	10% 16V
C1505	1-114-325-11	CERAMIC CHIP 0.1uF	10% 25V	C3213	1-112-246-11	ELECT 100uF	20% 35V
C1506	1-112-778-11	CERAMIC CHIP 0.022uF	10% 25V	C3214	1-114-868-11	CERAMIC CHIP 0.1uF	10% 50V
C1507	1-126-964-11	ELECT 10uF	20% 50V	C3215	1-114-325-11	CERAMIC CHIP 0.1uF	10% 25V
C1508	1-100-916-11	CERAMIC CHIP 0.1uF	10% 16V	C3221	1-100-907-11	CERAMIC CHIP 0.1uF	10% 10V
C1509	1-100-916-11	CERAMIC CHIP 0.1uF	10% 16V	C3222	1-114-325-11	CERAMIC CHIP 0.1uF	10% 25V

HBD-DZ340M/DZ640M/DZ840K/DZ840M/DZ940K

MAIN

Ref. No.	Part No.	Description	Remark	Ref. No.	Part No.	Description	Remark
C3240	1-162-964-11	CERAMIC CHIP	0.001uF 10% 50V (RU, AEP, EA)	C3317	1-112-246-11	ELECT	100uF 20% 35V
C3241	1-162-964-11	CERAMIC CHIP	0.001uF 10% 50V (RU, AEP, EA)	C3318	1-114-868-11	CERAMIC CHIP	0.1uF 10% 50V
C3242	1-162-964-11	CERAMIC CHIP	0.001uF 10% 50V (RU, AEP, EA)	C3319	1-114-325-11	CERAMIC CHIP	0.1uF 10% 25V
C3243	1-162-964-11	CERAMIC CHIP	0.001uF 10% 50V (RU, AEP, EA)	C3322	1-100-907-11	CERAMIC CHIP	0.1uF 10% 10V
C3244	1-114-323-11	CERAMIC CHIP	0.01uF 10% 50V	C3323	1-114-325-11	CERAMIC CHIP	0.1uF 10% 25V
C3245	1-114-323-11	CERAMIC CHIP	0.01uF 10% 50V	C3327	1-112-746-11	CERAMIC CHIP	4.7uF 10% 6.3V
C3246	1-114-323-11	CERAMIC CHIP	0.01uF 10% 50V	C3328	1-112-746-11	CERAMIC CHIP	4.7uF 10% 6.3V
C3247	1-114-323-11	CERAMIC CHIP	0.01uF 10% 50V	C3329	1-114-325-11	CERAMIC CHIP	0.1uF 10% 25V
C3253	1-112-246-11	ELECT	100uF 20% 35V	C3330	1-100-916-11	CERAMIC CHIP	0.1uF 10% 16V
C3254	1-114-868-11	CERAMIC CHIP	0.1uF 10% 50V	C3336	1-112-781-11	CERAMIC CHIP	1uF 10% 10V
C3255	1-114-325-11	CERAMIC CHIP	0.1uF 10% 25V	C3337	1-114-325-11	CERAMIC CHIP	0.1uF 10% 25V
C3256	1-114-325-11	CERAMIC CHIP	0.1uF 10% 25V	C3340	1-100-916-11	CERAMIC CHIP	0.1uF 10% 16V
C3257	1-165-884-11	CERAMIC CHIP	2.2uF 10% 6.3V	C3341	1-112-746-11	CERAMIC CHIP	4.7uF 10% 6.3V
C3258	1-165-884-11	CERAMIC CHIP	2.2uF 10% 6.3V	C3342	1-114-325-11	CERAMIC CHIP	0.1uF 10% 25V
C3259	1-165-884-11	CERAMIC CHIP	2.2uF 10% 6.3V	C3343	1-114-325-11	CERAMIC CHIP	0.1uF 10% 25V
C3260	1-100-916-11	CERAMIC CHIP	0.1uF 10% 16V	C3345	1-114-325-11	CERAMIC CHIP	0.1uF 10% 25V
C3261	1-100-916-11	CERAMIC CHIP	0.1uF 10% 16V	C3346	1-114-325-11	CERAMIC CHIP	0.1uF 10% 25V
C3263	1-112-246-11	ELECT	100uF 20% 35V	C3347	1-100-916-11	CERAMIC CHIP	0.1uF 10% 16V
C3264	1-114-868-11	CERAMIC CHIP	0.1uF 10% 50V	C3348	1-107-826-11	CERAMIC CHIP	0.1uF 10% 16V
C3265	1-114-325-11	CERAMIC CHIP	0.1uF 10% 25V	C3350	1-126-923-91	ELECT	220uF 20% 10V
C3270	1-162-964-11	CERAMIC CHIP	0.001uF 10% 50V (RU, AEP, EA)	C3366	1-114-130-11	CERAMIC CHIP	1uF 10% 6.3V
C3271	1-162-964-11	CERAMIC CHIP	0.001uF 10% 50V (RU, AEP, EA)	C3367	1-112-746-11	CERAMIC CHIP	4.7uF 10% 6.3V
C3272	1-162-964-11	CERAMIC CHIP	0.001uF 10% 50V (RU, AEP, EA)	C3368	1-112-746-11	CERAMIC CHIP	4.7uF 10% 6.3V
C3273	1-162-964-11	CERAMIC CHIP	0.001uF 10% 50V (RU, AEP, EA)	C3375	1-100-916-11	CERAMIC CHIP	0.1uF 10% 16V
C3274	1-114-323-11	CERAMIC CHIP	0.01uF 10% 50V	C3379	1-114-325-11	CERAMIC CHIP	0.1uF 10% 25V
C3275	1-114-323-11	CERAMIC CHIP	0.01uF 10% 50V	C3380	1-114-325-11	CERAMIC CHIP	0.1uF 10% 25V
C3276	1-114-323-11	CERAMIC CHIP	0.01uF 10% 50V	C3381	1-114-325-11	CERAMIC CHIP	0.1uF 10% 25V
C3277	1-114-323-11	CERAMIC CHIP	0.01uF 10% 50V	C3382	1-114-323-11	CERAMIC CHIP	0.01uF 10% 50V
C3286	1-112-246-11	ELECT	100uF 20% 35V	C3383	1-112-746-11	CERAMIC CHIP	4.7uF 10% 6.3V
C3287	1-114-868-11	CERAMIC CHIP	0.1uF 10% 50V	C3384	1-114-325-11	CERAMIC CHIP	0.1uF 10% 25V
C3288	1-112-246-11	ELECT	100uF 20% 35V	C3385	1-164-850-11	CERAMIC CHIP	10PF 0.5PF 50V
C3289	1-114-868-11	CERAMIC CHIP	0.1uF 10% 50V	C3386	1-164-856-81	CERAMIC CHIP	18PF 5% 50V
C3290	1-114-325-11	CERAMIC CHIP	0.1uF 10% 25V	C3387	1-114-323-11	CERAMIC CHIP	0.01uF 10% 50V
C3291	1-114-325-11	CERAMIC CHIP	0.1uF 10% 25V	C3388	1-112-746-11	CERAMIC CHIP	4.7uF 10% 6.3V
C3292	1-112-246-11	ELECT	100uF 20% 35V	C3389	1-107-826-11	CERAMIC CHIP	0.1uF 10% 16V
C3293	1-114-868-11	CERAMIC CHIP	0.1uF 10% 50V	C3390	1-100-916-11	CERAMIC CHIP	0.1uF 10% 16V
C3294	1-112-246-11	ELECT	100uF 20% 35V	C3391	1-112-746-11	CERAMIC CHIP	4.7uF 10% 6.3V
C3295	1-114-868-11	CERAMIC CHIP	0.1uF 10% 50V	C3403	1-112-246-11	ELECT	100uF 20% 35V
C3296	1-114-325-11	CERAMIC CHIP	0.1uF 10% 25V	C3404	1-114-868-11	CERAMIC CHIP	0.1uF 10% 50V
C3297	1-100-916-11	CERAMIC CHIP	0.1uF 10% 16V	C3405	1-114-325-11	CERAMIC CHIP	0.1uF 10% 25V
C3298	1-100-916-11	CERAMIC CHIP	0.1uF 10% 16V	C3406	1-165-884-11	CERAMIC CHIP	2.2uF 10% 6.3V
C3301	1-100-907-11	CERAMIC CHIP	0.1uF 10% 10V	C3410	1-100-916-11	CERAMIC CHIP	0.1uF 10% 16V
C3302	1-114-325-11	CERAMIC CHIP	0.1uF 10% 25V	C3411	1-100-916-11	CERAMIC CHIP	0.1uF 10% 16V
C3303	1-112-781-11	CERAMIC CHIP	1uF 10% 10V	C3413	1-112-246-11	ELECT	100uF 20% 35V
C3305	1-100-916-11	CERAMIC CHIP	0.1uF 10% 16V	C3414	1-114-868-11	CERAMIC CHIP	0.1uF 10% 50V
C3306	1-112-246-11	ELECT	100uF 20% 35V	C3415	1-114-325-11	CERAMIC CHIP	0.1uF 10% 25V
C3307	1-100-916-11	CERAMIC CHIP	0.1uF 10% 16V	C3551	1-112-781-11	CERAMIC CHIP	1uF 10% 10V
C3308	1-114-868-11	CERAMIC CHIP	0.1uF 10% 50V	C3552	1-126-964-11	ELECT	10uF 20% 50V
C3309	1-114-325-11	CERAMIC CHIP	0.1uF 10% 25V	C3553	1-112-777-11	CERAMIC CHIP	0.01uF 10% 25V
C3310	1-165-884-11	CERAMIC CHIP	2.2uF 10% 6.3V	C3556	1-100-916-11	CERAMIC CHIP	0.1uF 10% 16V
C3311	1-112-781-11	CERAMIC CHIP	1uF 10% 10V	C3561	1-126-947-11	ELECT	47uF 20% 35V
C3312	1-114-325-11	CERAMIC CHIP	0.1uF 10% 25V	C3601	1-114-325-11	CERAMIC CHIP	0.1uF 10% 25V
C3314	1-100-916-11	CERAMIC CHIP	0.1uF 10% 16V	C3603	1-100-907-11	CERAMIC CHIP	0.1uF 10% 10V
C3315	1-100-916-11	CERAMIC CHIP	0.1uF 10% 16V	C3605	1-126-941-11	ELECT	470uF 20% 25V
				C3606	1-126-935-11	ELECT	470uF 20% 16V
				C3607	1-100-916-11	CERAMIC CHIP	0.1uF 10% 16V
				C3608	1-114-325-11	CERAMIC CHIP	0.1uF 10% 25V
				C3905	1-162-964-11	CERAMIC CHIP	0.001uF 10% 50V (RU, AEP, EA)
				C3906	1-162-964-11	CERAMIC CHIP	0.001uF 10% 50V (RU, AEP, EA)

Ref. No.	Part No.	Description	Remark	Ref. No.	Part No.	Description	Remark
C3907	1-162-964-11	CERAMIC CHIP	0.001uF 10% 50V (RU, AEP, EA)	C5013	1-100-916-11	CERAMIC CHIP	0.1uF 10% 16V
C3908	1-162-964-11	CERAMIC CHIP	0.001uF 10% 50V (RU, AEP, EA)	C5014	1-114-320-11	CERAMIC CHIP	0.22uF 10% 6.3V
C3915	1-114-323-11	CERAMIC CHIP	0.01uF 10% 50V	C5015	1-112-777-11	CERAMIC CHIP	0.01uF 10% 25V
C3916	1-114-323-11	CERAMIC CHIP	0.01uF 10% 50V	C5016	1-100-916-11	CERAMIC CHIP	0.1uF 10% 16V
C3917	1-114-323-11	CERAMIC CHIP	0.01uF 10% 50V	C5018	1-112-778-11	CERAMIC CHIP	0.022uF 10% 25V
C3918	1-114-323-11	CERAMIC CHIP	0.01uF 10% 50V	C5019	1-104-656-11	ELECT	2200uF 20% 6.3V
C3919	1-114-130-11	CERAMIC CHIP	1uF 10% 6.3V	C5020	1-126-925-91	ELECT	470uF 20% 10V
C3920	1-114-130-11	CERAMIC CHIP	1uF 10% 6.3V	C5022	1-100-916-11	CERAMIC CHIP	0.1uF 10% 16V
C3921	1-137-649-31	ELECT	220uF 20% 10V	C5023	1-112-777-11	CERAMIC CHIP	0.01uF 10% 25V
C3922	1-114-130-11	CERAMIC CHIP	1uF 10% 6.3V	C5025	1-164-937-11	CERAMIC CHIP	0.001uF 10% 50V
C3923	1-114-130-11	CERAMIC CHIP	1uF 10% 6.3V	C5026	1-164-874-11	CERAMIC CHIP	100PF 5% 50V
C3924	1-100-916-11	CERAMIC CHIP	0.1uF 10% 16V	C6003	1-126-923-91	ELECT	220uF 20% 10V
C3925	1-114-325-11	CERAMIC CHIP	0.1uF 10% 25V	C6004	1-114-323-11	CERAMIC CHIP	0.01uF 10% 50V
C3930	1-100-909-11	CERAMIC CHIP	10uF 10% 6.3V	C6007	1-126-923-91	ELECT	220uF 20% 10V
C3935	1-131-700-31	FILM	0.47uF 5% 50V	C6011	1-164-856-81	CERAMIC CHIP	18PF 5% 50V
C3936	1-131-700-31	FILM	0.47uF 5% 50V	C6012	1-164-852-11	CERAMIC CHIP	12PF 5% 50V
C3937	1-131-700-31	FILM	0.47uF 5% 50V	C6018	1-114-325-11	CERAMIC CHIP	0.1uF 10% 25V
C3938	1-131-700-31	FILM	0.47uF 5% 50V	C6019	1-126-964-11	ELECT	10uF 20% 50V
C3941	1-131-700-31	FILM	0.47uF 5% 50V	C6020	1-114-325-11	CERAMIC CHIP	0.1uF 10% 25V
C3942	1-131-700-31	FILM	0.47uF 5% 50V	C6021	1-126-964-11	ELECT	10uF 20% 50V
C3943	1-131-700-31	FILM	0.47uF 5% 50V	C6022	1-114-325-11	CERAMIC CHIP	0.1uF 10% 25V
C3944	1-131-700-31	FILM	0.47uF 5% 50V	C6052	1-104-658-91	ELECT	100uF 20% 10V (DZ840K/DZ840M/DZ940K)
C3945	1-131-700-31	FILM	0.47uF 5% 50V	C6053	1-114-325-11	CERAMIC CHIP	0.1uF 10% 25V (DZ840K/DZ840M/DZ940K)
C3946	1-131-700-31	FILM	0.47uF 5% 50V	C7001	1-100-916-11	CERAMIC CHIP	0.1uF 10% 16V
C3947	1-131-700-31	FILM	0.47uF 5% 50V	C7002	1-100-916-11	CERAMIC CHIP	0.1uF 10% 16V (DZ640M/DZ840K/DZ840M/DZ940K)
C3948	1-131-700-31	FILM	0.47uF 5% 50V	C7003	1-100-916-11	CERAMIC CHIP	0.1uF 10% 16V (DZ640M/DZ840K/DZ840M/DZ940K)
C3950	1-112-256-11	ELECT	1500uF 20% 35V (AEP, E3, E12, E15, EA)	C7004	1-100-916-11	CERAMIC CHIP	0.1uF 10% 16V (DZ640M/DZ840K/DZ840M/DZ940K)
C3950	1-116-856-11	ELECT	1000uF 20% 35V (RU, PH, SP, TH)	C7005	1-114-130-11	CERAMIC CHIP	1uF 10% 6.3V
C3951	1-112-256-11	ELECT	1500uF 20% 35V (AEP, E3, E12, E15, EA)	C7006	1-100-909-11	CERAMIC CHIP	10uF 10% 6.3V (DZ640M/DZ840K/DZ840M/DZ940K)
C3951	1-116-856-11	ELECT	1000uF 20% 35V (RU, PH, SP, TH)	C7013	1-112-781-11	CERAMIC CHIP	1uF 10% 10V
C3953	1-112-256-11	ELECT	1500uF 20% 35V (AEP, E3, E12, E15, EA)	C7015	1-100-909-11	CERAMIC CHIP	10uF 10% 6.3V (DZ640M/DZ840K/DZ840M/DZ940K)
C3953	1-116-856-11	ELECT	1000uF 20% 35V (RU, PH, SP, TH)	C7018	1-114-325-11	CERAMIC CHIP	0.1uF 10% 25V (DZ640M/DZ840K/DZ840M/DZ940K)
C3954	1-112-256-11	ELECT	1500uF 20% 35V (AEP, E3, E12, E15, EA)	C7021	1-100-916-11	CERAMIC CHIP	0.1uF 10% 16V (DZ340M)
C3954	1-116-856-11	ELECT	1000uF 20% 35V (RU, PH, SP, TH)	C7022	1-100-909-11	CERAMIC CHIP	10uF 10% 6.3V (DZ340M)
C3955	1-112-256-11	ELECT	1500uF 20% 35V (AEP, E3, E12, E15, EA)			< CONNECTOR >	
C3955	1-116-856-11	ELECT	1000uF 20% 35V (RU, PH, SP, TH)	CN1101	1-819-318-21	CONNECTOR, FFC/FPC (ZIF) 24P	
C3956	1-164-874-11	CERAMIC CHIP	100PF 5% 50V	CN1105	1-770-470-21	PIN, CONNECTOR (PC BOARD) 6P	
C3957	1-164-874-11	CERAMIC CHIP	100PF 5% 50V (RU, AEP, EA)	CN1501	1-564-708-11	PIN, CONNECTOR (SMALL TYPE) 6P	
C3958	1-164-937-11	CERAMIC CHIP	0.001uF 10% 50V (RU, AEP, EA)	CN1502	1-779-273-11	CONNECTOR, FFC (LIF (NON-ZIF)) 5P	
C5001	1-114-130-11	CERAMIC CHIP	1uF 10% 6.3V	CN1701	1-842-519-11	CONNECTOR, HDMI 19P (HDMI OUT (ARC))	
C5003	1-114-130-11	CERAMIC CHIP	1uF 10% 6.3V	CN1801	1-564-707-11	PIN, CONNECTOR (SMALL TYPE) 5P	
C5005	1-114-323-11	CERAMIC CHIP	0.01uF 10% 50V	CN3002	1-564-704-41	PIN, CONNECTOR (SMALL TYPE) 2P	
C5006	1-114-325-11	CERAMIC CHIP	0.1uF 10% 25V	CN3004	1-564-507-11	PLUG, CONNECTOR 4P (DZ340M/DZ640M/DZ840M)	
C5007	1-114-323-11	CERAMIC CHIP	0.01uF 10% 50V	* CN3005	1-564-508-11	PLUG, CONNECTOR 5P (DZ840K/DZ940K)	
C5008	1-114-323-11	CERAMIC CHIP	0.01uF 10% 50V	CN3010	1-785-468-41	CONNECTOR, FFC/FPC 13P	
C5009	1-100-916-11	CERAMIC CHIP	0.1uF 10% 16V	CN5002	1-784-861-51	CONNECTOR, FFC (LIF (NON-ZIF)) 9P	
C5010	1-114-325-11	CERAMIC CHIP	0.1uF 10% 25V	CN5006	1-820-115-41	CONNECTOR, FFC/FPC 15P	
C5011	1-114-325-11	CERAMIC CHIP	0.1uF 10% 25V			< DIODE >	
C5012	1-114-325-11	CERAMIC CHIP	0.1uF 10% 25V	D1711	6-503-020-01	DIODE DZ2J082M0L	

HBD-DZ340M/DZ640M/DZ840K/DZ840M/DZ940K

Ver. 1.2

MAIN

Ref. No.	Part No.	Description	Remark	Ref. No.	Part No.	Description	Remark
D1714	6-502-961-01	DIODE DA2J10100L		IC7003	6-716-690-01	IC NJM2561F1-A(TE2 (DZ340M))	
D3551	6-500-848-01	DIODE MC2840-T112-1				< JACK >	
D5001	6-502-961-01	DIODE DA2J10100L		J7001	1-822-283-11	JACK, PIN 3P (COMPONENT VIDEO OUT) (DZ640M/DZ840K/DZ840M/DZ940K)	
D5002	6-502-961-01	DIODE DA2J10100L		J7002	1-794-970-11	JACK, PIN 1P (VIDEO OUT)	
D5004	6-502-961-01	DIODE DA2J10100L				< COIL >	
D5006	6-502-961-01	DIODE DA2J10100L					
		< FERRITE BEAD >					
FB1106	1-481-348-21	EMI FERRITE (SMD) (1608)		L1802	1-414-840-11	INDUCTOR 10nH	
FB1107	1-481-348-21	EMI FERRITE (SMD) (1608)		L1803	1-414-840-11	INDUCTOR 10nH	
FB1108	1-481-348-21	EMI FERRITE (SMD) (1608)		L3002	1-457-933-11	COIL, CHOKE 150uH	
FB1109	1-481-348-21	EMI FERRITE (SMD) (1608)		L3052	1-400-791-21	INDUCTOR 10uH	
FB1111	1-481-349-21	EMI FERRITE (SMD) (1608)		* L3053	1-481-642-11	INDUCTOR 10uH (DZ340M/DZ640M/DZ840M)	
FB1112	1-481-349-21	EMI FERRITE (SMD) (1608)					
FB1113	1-481-349-21	EMI FERRITE (SMD) (1608)		L3201	1-457-579-11	COIL, CHOKE 10uH	
FB1115	1-481-349-21	EMI FERRITE (SMD) (1608)		L3251	1-457-579-11	COIL, CHOKE 10uH	
FB1116	1-481-349-21	EMI FERRITE (SMD) (1608)		L3301	1-457-579-11	COIL, CHOKE 10uH	
FB1117	1-481-349-21	EMI FERRITE (SMD) (1608)		L3302	1-469-525-91	INDUCTOR 10uH	
FB1118	1-481-349-21	EMI FERRITE (SMD) (1608)		L3401	1-457-579-11	COIL, CHOKE 10uH	
FB1203	1-481-348-21	EMI FERRITE (SMD) (1608)		L3501	1-457-579-11	COIL, CHOKE 10uH	
FB2101	1-481-348-21	EMI FERRITE (SMD) (1608)		L3551	1-457-579-11	COIL, CHOKE 10uH	
FB2124	1-400-632-21	BEAD, FERRITE (1005)		* L6002	1-481-642-11	INDUCTOR 10uH (DZ840K/DZ840M/DZ940K)	
FB2125	1-400-632-21	BEAD, FERRITE (1005)					
FB3001	1-400-632-21	BEAD, FERRITE (1005)		* L6003	1-481-642-11	INDUCTOR 10uH	
		< IC >		* L6007	1-481-642-11	INDUCTOR 10uH	
IC1001	6-709-888-01	IC TC7WHU04FK				< TRANSISTOR >	
IC1101	6-714-722-01	IC CXD9927R-B		Q1101	6-552-279-01	FET RT3K66M-T111-1	
IC1102	6-717-444-01	IC MX29LV320EBTI-70-OHD-1102CE (RU, AEP, E3, E12, E15, EA)		Q1102	6-550-653-01	TRANSISTOR QST8TR	
IC1102	6-717-445-01	IC MX29LV320EBTI-70-OHD-1102GA (PH, SP, TH)		Q1103	8-729-038-37	TRANSISTOR RT1N141M-TP-1	
IC1103	(Not supplied)	IC R1EX24064ASAS0A		Q1701	6-552-279-01	FET RT3K66M-T111-1	
IC1104	6-716-354-01	IC W9864G6JH-6-ER10		Q1702	6-551-272-01	TRANSISTOR RT3CLLM	
IC1105	6-715-134-01	IC MM3404A33URE		Q1706	6-551-714-01	FET INK0001AC1-T112-1	
IC1107	6-715-134-01	IC MM3404A33URE		Q3001	6-551-272-01	TRANSISTOR RT3CLLM	
IC1110	6-716-833-01	IC MM3374A18PRE		Q3002	8-729-056-46	TRANSISTOR 2SC5053T100Q	
IC1501	(Not supplied)	IC BD8203EFV-E2		Q3201	6-552-772-01	TRANSISTOR RT3AMMAM1-T111-1F	
IC1502	6-716-834-01	IC MM1836A50NRE		Q3202	6-552-772-01	TRANSISTOR RT3AMMAM1-T111-1F	
IC1705	8-759-592-47	IC TC7SZ08FU(TE85R)		Q3251	6-552-772-01	TRANSISTOR RT3AMMAM1-T111-1F	
IC1707	6-705-337-01	IC TK11150CSCL-G		Q3252	6-552-772-01	TRANSISTOR RT3AMMAM1-T111-1F	
IC1708	6-702-302-01	IC TK11133CSCL-G		Q3301	6-552-772-01	TRANSISTOR RT3AMMAM1-T111-1F	
IC1709	6-716-739-01	IC BD00GC0WEFJ-SE2		Q3401	6-552-772-01	TRANSISTOR RT3AMMAM1-T111-1F	
IC3001	6-712-974-01	IC CXD9926ATQ		Q3551	8-729-620-13	TRANSISTOR 2SC4154TP-1EF	
IC3002	6-710-366-01	IC 74LVC1G04GW-125		Q3552	6-551-272-01	TRANSISTOR RT3CLLM	
IC3003	6-712-613-01	IC SI-3010KM-TLS		Q5001	8-729-620-13	TRANSISTOR 2SC4154TP-1EF	
IC3100	6-714-477-01	IC CXD9981TN		Q5002	6-551-272-01	TRANSISTOR RT3CLLM	
IC3300	6-714-477-01	IC CXD9981TN		Q5003	6-552-458-01	FET 2SK3577-T1B-AT	
IC3350	6-714-477-01	IC CXD9981TN				< RESISTOR >	
IC3401	6-715-134-01	IC MM3404A33URE		R1001	1-218-953-11	METAL CHIP 1K 5% 1/16W	
IC3402	6-715-134-01	IC MM3404A33URE		R1002	1-208-911-11	METAL CHIP 10K 0.5% 1/16W	
IC5001	6-716-832-01	IC MM3374A33PRE		R1003	1-208-927-11	METAL CHIP 47K 0.5% 1/16W	
IC5002	A-1797-153-A	IC R5F3650KBDF A (for SERVICE)		R1004	1-218-863-11	METAL CHIP 4.7K 0.5% 1/10W	
IC5004	(Not supplied)	IC S-80935CANNB-G85T2G		R1005	1-218-847-11	METAL CHIP 1K 0.5% 1/10W	
IC6001	(Not supplied)	IC CS8422					
IC6002	6-600-466-01	IC TORX147L(SONY) (TV/OPTICAL DIGITAL IN) (DZ840K/DZ840M/DZ940K)		R1006	1-218-965-11	METAL CHIP 10K 5% 1/16W	
IC7001	6-716-592-01	IC BH76071FJ-E2 (DZ640M/DZ840K/DZ840M/DZ940K)		R1007	1-216-821-11	METAL CHIP 1K 5% 1/10W	
IC7002	6-716-834-01	IC MM1836A50NRE		R1011	1-216-849-11	METAL CHIP 220K 5% 1/10W	
				R1012	1-216-864-11	SHORT CHIP 0	
				R1013	1-216-817-11	METAL CHIP 470 5% 1/10W	
				R1014	1-216-841-11	METAL CHIP 47K 5% 1/10W	
				R1015	1-208-859-81	METAL CHIP 68 0.5% 1/16W	
				R1016	1-208-859-81	METAL CHIP 68 0.5% 1/16W	

Note: When IC1103, IC1501, IC5004 and IC6001 on the Main board are damaged, exchange the new Main board for the Main board which IC damaged.

Ref. No.	Part No.	Description	Remark	Ref. No.	Part No.	Description	Remark
R1101	1-216-809-11	METAL CHIP	100 5%	1/10W	R1537	1-218-853-11	METAL CHIP 1.8K 0.5% 1/10W
R1103	1-218-864-11	METAL CHIP	5.1K 0.5%	1/10W	R1538	1-218-863-11	METAL CHIP 4.7K 0.5% 1/10W
R1105	1-216-833-11	METAL CHIP	10K 5%	1/10W	R1539	1-208-699-11	METAL CHIP 4.7K 0.5% 1/16W
R1106	1-216-833-11	METAL CHIP	10K 5%	1/10W	R1540	1-208-703-11	METAL CHIP 6.8K 0.5% 1/16W
R1107	1-218-965-11	METAL CHIP	10K 5%	1/16W	R1541	1-208-699-11	METAL CHIP 4.7K 0.5% 1/16W
R1108	1-218-989-11	METAL CHIP	1M 5%	1/16W	R1542	1-208-703-11	METAL CHIP 6.8K 0.5% 1/16W
R1109	1-218-990-81	SHORT CHIP	0		R1543	1-218-965-11	METAL CHIP 10K 5% 1/16W
R1110	1-218-973-11	METAL CHIP	47K 5%	1/16W	R1544	1-216-797-11	METAL CHIP 10 5% 1/10W
R1111	1-218-941-81	METAL CHIP	100 5%	1/16W	R1730	1-216-826-11	METAL CHIP 2.7K 5% 1/10W
R1112	1-208-643-11	METAL CHIP	22 0.5%	1/16W	R1742	1-218-973-11	METAL CHIP 47K 5% 1/16W
R1113	1-208-643-11	METAL CHIP	22 0.5%	1/16W	R1744	1-216-829-11	METAL CHIP 4.7K 5% 1/10W
R1114	1-218-977-11	METAL CHIP	100K 5%	1/16W	R1749	1-216-824-11	METAL CHIP 1.8K 5% 1/10W
R1115	1-208-643-11	METAL CHIP	22 0.5%	1/16W	R1750	1-216-824-11	METAL CHIP 1.8K 5% 1/10W
R1116	1-218-953-11	METAL CHIP	1K 5%	1/16W	R1751	1-216-864-11	SHORT CHIP 0
R1117	1-218-973-11	METAL CHIP	47K 5%	1/16W	R1752	1-216-821-11	METAL CHIP 1K 5% 1/10W
R1118	1-218-933-11	METAL CHIP	22 5%	1/16W	R1781	1-216-827-11	METAL CHIP 3.3K 5% 1/10W
R1120	1-218-933-11	METAL CHIP	22 5%	1/16W	R1782	1-216-827-11	METAL CHIP 3.3K 5% 1/10W
R1121	1-218-933-11	METAL CHIP	22 5%	1/16W	R1801	1-208-677-11	METAL CHIP 560 0.5% 1/16W
R1123	1-218-990-81	SHORT CHIP	0		R1803	1-218-958-11	METAL CHIP 2.7K 5% 1/16W
R1124	1-218-973-11	METAL CHIP	47K 5%	1/16W	R1805	1-218-990-81	SHORT CHIP 0
R1125	1-218-937-11	METAL CHIP	47 5%	1/16W	R1811	1-216-845-11	METAL CHIP 100K 5% 1/10W
R1126	1-216-833-11	METAL CHIP	10K 5%	1/10W	R1817	1-216-827-11	METAL CHIP 3.3K 5% 1/10W
R1132	1-216-845-11	METAL CHIP	100K 5%	1/10W	R1818	1-216-827-11	METAL CHIP 3.3K 5% 1/10W
R1133	1-216-864-11	SHORT CHIP	0		R1819	1-216-827-11	METAL CHIP 3.3K 5% 1/10W
R1135	1-216-821-11	METAL CHIP	1K 5%	1/10W	R1828	1-216-821-11	METAL CHIP 1K 5% 1/10W
R1136	1-218-967-11	METAL CHIP	15K 5%	1/16W	R1829	1-216-809-11	METAL CHIP 100 5% 1/10W
R1140	1-216-829-11	METAL CHIP	4.7K 5%	1/10W	R1830	1-216-833-11	METAL CHIP 10K 5% 1/10W
R1141	1-216-855-11	METAL CHIP	680K 5%	1/10W	R1835	1-218-965-11	METAL CHIP 10K 5% 1/16W
R1142	1-218-977-11	METAL CHIP	100K 5%	1/16W	R1836	1-218-965-11	METAL CHIP 10K 5% 1/16W
R1151	1-218-965-11	METAL CHIP	10K 5%	1/16W	R1837	1-218-965-11	METAL CHIP 10K 5% 1/16W
R1154	1-216-809-11	METAL CHIP	100 5%	1/10W	R1838	1-218-957-11	METAL CHIP 2.2K 5% 1/16W
R1155	1-216-809-11	METAL CHIP	100 5%	1/10W	R1909	1-218-970-11	METAL CHIP 27K 5% 1/16W
R1156	1-218-941-81	METAL CHIP	100 5%	1/16W	R1910	1-218-970-11	METAL CHIP 27K 5% 1/16W
R1159	1-218-941-81	METAL CHIP	100 5%	1/16W	R1911	1-218-945-11	METAL CHIP 220 5% 1/16W
R1160	1-218-929-11	METAL CHIP	10 5%	1/16W	R2114	1-218-933-11	METAL CHIP 22 5% 1/16W
R1164	1-216-809-11	METAL CHIP	100 5%	1/10W	R2120	1-218-941-81	METAL CHIP 100 5% 1/16W
R1171	1-216-809-11	METAL CHIP	100 5%	1/10W	R2131	1-216-809-11	METAL CHIP 100 5% 1/10W
R1183	1-234-371-21	RES, NETWORK 47X4 (1005)			R2155	1-216-833-11	METAL CHIP 10K 5% 1/10W
R1186	1-218-953-11	METAL CHIP	1K 5%	1/16W	R2156	1-216-833-11	METAL CHIP 10K 5% 1/10W
R1191	1-216-821-11	METAL CHIP	1K 5%	1/10W	R2157	1-216-833-11	METAL CHIP 10K 5% 1/10W
R1192	1-216-821-11	METAL CHIP	1K 5%	1/10W	R2158	1-216-833-11	METAL CHIP 10K 5% 1/10W
R1193	1-216-821-11	METAL CHIP	1K 5%	1/10W	R2159	1-216-833-11	METAL CHIP 10K 5% 1/10W
R1198	1-216-809-11	METAL CHIP	100 5%	1/10W	R2160	1-216-833-11	METAL CHIP 10K 5% 1/10W
R1501	1-216-821-11	METAL CHIP	1K 5%	1/10W	R2168	1-218-947-11	METAL CHIP 330 5% 1/16W
R1502	1-234-375-21	RES, NETWORK 1KX4 (1005)			R2184	1-216-809-11	METAL CHIP 100 5% 1/10W
R1504	1-216-829-11	METAL CHIP	4.7K 5%	1/10W	R2185	1-216-809-11	METAL CHIP 100 5% 1/10W
R1505	1-218-953-11	METAL CHIP	1K 5%	1/16W	R2186	1-218-953-11	METAL CHIP 1K 5% 1/16W
R1512	1-208-927-11	METAL CHIP	47K 0.5%	1/16W	R3001	1-216-833-11	METAL CHIP 10K 5% 1/10W
R1513	1-208-715-11	METAL CHIP	22K 0.5%	1/16W	R3002	1-218-965-11	METAL CHIP 10K 5% 1/16W
R1517	1-216-815-11	METAL CHIP	330 5%	1/10W	R3003	1-218-955-11	METAL CHIP 1.5K 5% 1/16W
R1518	1-208-923-11	METAL CHIP	33K 0.5%	1/16W	R3004	1-218-955-11	METAL CHIP 1.5K 5% 1/16W
R1519	1-208-713-11	METAL CHIP	18K 0.5%	1/16W	R3006	1-218-957-11	METAL CHIP 2.2K 5% 1/16W
R1521	1-218-893-11	METAL CHIP	82K 0.5%	1/10W	R3015	1-218-937-11	METAL CHIP 47 5% 1/16W
R1525	1-208-711-11	METAL CHIP	15K 0.5%	1/16W	R3016	1-218-937-11	METAL CHIP 47 5% 1/16W
R1526	1-218-967-11	METAL CHIP	15K 5%	1/16W	R3051	1-218-977-11	METAL CHIP 100K 5% 1/16W
R1527	1-218-965-11	METAL CHIP	10K 5%	1/16W	R3053	1-216-864-11	SHORT CHIP 0 (DZ840K/DZ940K)
R1529	1-216-864-11	SHORT CHIP	0		R3065	1-218-941-81	METAL CHIP 100 5% 1/16W
R1532	1-218-965-11	METAL CHIP	10K 5%	1/16W	R3075	1-234-371-21	RES, NETWORK 47X4 (1005)
R1535	1-218-863-11	METAL CHIP	4.7K 0.5%	1/10W	R3080	1-216-845-11	METAL CHIP 100K 5% 1/10W
R1536	1-218-863-11	METAL CHIP	4.7K 0.5%	1/10W	R3111	1-216-864-11	SHORT CHIP 0

HBD-DZ340M/DZ640M/DZ840K/DZ840M/DZ940K

MAIN

Ref. No.	Part No.	Description	Remark	Ref. No.	Part No.	Description	Remark
R3112	1-216-864-11	SHORT CHIP	0	R3501	1-234-371-21	RES, NETWORK 47X4 (1005)	
R3113	1-216-864-11	SHORT CHIP	0	R3551	1-218-977-11	METAL CHIP	100K 5% 1/16W
R3205	1-216-845-11	METAL CHIP	100K 5%	R3552	1-218-969-11	METAL CHIP	22K 5% 1/16W
R3206	1-216-845-11	METAL CHIP	100K 5%	R3553	1-216-833-11	METAL CHIP	10K 5% 1/10W
R3207	1-216-845-11	METAL CHIP	100K 5%	R3554	1-218-977-11	METAL CHIP	100K 5% 1/16W
R3221	1-216-821-11	METAL CHIP	1K 5%	R3558	1-208-687-11	METAL CHIP	1.5K 0.5% 1/16W
R3222	1-216-821-11	METAL CHIP	1K 5%	R3561	1-218-973-11	METAL CHIP	47K 5% 1/16W
R3223	1-216-837-11	METAL CHIP	22K 5%	R3562	1-208-923-11	METAL CHIP	33K 0.5% 1/16W
R3224	1-216-837-11	METAL CHIP	22K 5%	R3563	1-208-699-11	METAL CHIP	4.7K 0.5% 1/16W
R3257	1-216-845-11	METAL CHIP	100K 5%	R3609	1-216-813-11	METAL CHIP	220 5% 1/10W
R3258	1-216-845-11	METAL CHIP	100K 5%	R3610	1-216-813-11	METAL CHIP	220 5% 1/10W
R3259	1-216-845-11	METAL CHIP	100K 5%	R3622	1-218-943-11	METAL CHIP	150 5% 1/16W
R3301	1-234-371-21	RES, NETWORK 47X4 (1005)		R3628	1-218-977-11	METAL CHIP	100K 5% 1/16W
R3303	1-216-845-11	METAL CHIP	100K 5%	R3629	1-218-965-11	METAL CHIP	10K 5% 1/16W
R3304	1-216-845-11	METAL CHIP	100K 5%	R3630	1-218-953-11	METAL CHIP	1K 5% 1/16W
R3305	1-216-845-11	METAL CHIP	100K 5%	R3631	1-218-965-11	METAL CHIP	10K 5% 1/16W
R3306	1-216-833-11	METAL CHIP	10K 5%	R3919	1-218-953-11	METAL CHIP	1K 5% 1/16W
R3307	1-216-833-11	METAL CHIP	10K 5%	R3922	1-218-953-11	METAL CHIP	1K 5% 1/16W
R3310	1-218-941-81	METAL CHIP	100 5%	R3960	1-216-845-11	METAL CHIP	100K 5% 1/10W
R3319	1-218-933-11	METAL CHIP	22 5%	R3961	1-216-845-11	METAL CHIP	100K 5% 1/10W
R3321	1-216-833-11	METAL CHIP	10K 5%	R3962	1-216-845-11	METAL CHIP	100K 5% 1/10W
R3322	1-216-821-11	METAL CHIP	1K 5%	R3963	1-216-845-11	METAL CHIP	100K 5% 1/10W
R3323	1-216-837-11	METAL CHIP	22K 5%	R3964	1-216-845-11	METAL CHIP	100K 5% 1/10W
R3327	1-218-965-11	METAL CHIP	10K 5%	R3965	1-216-845-11	METAL CHIP	100K 5% 1/10W
R3328	1-216-833-11	METAL CHIP	10K 5%	R3972	1-216-864-11	SHORT CHIP	0
R3329	1-216-833-11	METAL CHIP	10K 5%	R3974	1-216-864-11	SHORT CHIP	0 (DZ340M/DZ640M/DZ840M)
R3330	1-218-965-11	METAL CHIP	10K 5%	R5001	1-218-953-11	METAL CHIP	1K 5% 1/16W
R3331	1-216-825-11	METAL CHIP	2.2K 5%	R5002	1-216-821-11	METAL CHIP	1K 5% 1/10W
R3332	1-216-825-11	METAL CHIP	2.2K 5%	R5008	1-216-857-11	METAL CHIP	1M 5% 1/10W
R3333	1-218-990-81	SHORT CHIP	0	R5012	1-216-841-11	METAL CHIP	47K 5% 1/10W
R3334	1-218-990-81	SHORT CHIP	0	R5018	1-218-965-11	METAL CHIP	10K 5% 1/16W
R3335	1-216-833-11	METAL CHIP	10K 5%	R5019	1-218-965-11	METAL CHIP	10K 5% 1/16W
R3338	1-218-941-81	METAL CHIP	100 5%	R5020	1-218-973-11	METAL CHIP	47K 5% 1/16W
R3339	1-216-821-11	METAL CHIP	1K 5%	R5026	1-218-990-81	SHORT CHIP	0
R3341	1-218-965-11	METAL CHIP	10K 5%	R5027	1-218-989-11	METAL CHIP	1M 5% 1/16W
R3342	1-218-965-11	METAL CHIP	10K 5%	R5029	1-216-829-11	METAL CHIP	4.7K 5% 1/10W
R3343	1-218-941-81	METAL CHIP	100 5%	R5030	1-216-829-11	METAL CHIP	4.7K 5% 1/10W
R3344	1-218-941-81	METAL CHIP	100 5%	R5031	1-216-829-11	METAL CHIP	4.7K 5% 1/10W
R3360	1-218-970-11	METAL CHIP	27K 5%	R5032	1-216-829-11	METAL CHIP	4.7K 5% 1/10W
R3361	1-218-970-11	METAL CHIP	27K 5%	R5033	1-216-833-11	METAL CHIP	10K 5% 1/10W
R3362	1-218-975-11	METAL CHIP	68K 5%	R5037	1-218-977-11	METAL CHIP	100K 5% 1/16W
R3365	1-218-975-11	METAL CHIP	68K 5%	R5038	1-216-833-11	METAL CHIP	10K 5% 1/10W
R3368	1-218-975-11	METAL CHIP	68K 5%	R5040	1-216-833-11	METAL CHIP	10K 5% 1/10W
R3369	1-218-975-11	METAL CHIP	68K 5%	R5041	1-216-833-11	METAL CHIP	10K 5% 1/10W
R3371	1-220-199-81	METAL CHIP	24K 5%	R5046	1-216-833-11	METAL CHIP	10K 5% 1/10W
R3372	1-218-990-81	SHORT CHIP	0 (DZ340M/DZ640M/DZ840M)	R5047	1-218-981-91	METAL CHIP	220K 5% 1/16W
R3374	1-218-990-81	SHORT CHIP	0	R5048	1-218-957-11	METAL CHIP	2.2K 5% 1/16W
R3375	1-218-990-81	SHORT CHIP	0	R5050	1-218-953-11	METAL CHIP	1K 5% 1/16W
R3376	1-218-990-81	SHORT CHIP	0	R5051	1-216-845-11	METAL CHIP	100K 5% 1/10W
R3377	1-218-990-81	SHORT CHIP	0 (DZ340M/DZ640M/DZ840M)	R5052	1-218-941-81	METAL CHIP	100 5% 1/16W
R3378	1-218-990-81	SHORT CHIP	0	R5054	1-218-973-11	METAL CHIP	47K 5% 1/16W
R3379	1-216-864-11	SHORT CHIP	0 (DZ840K/DZ940K)	R5055	1-218-953-11	METAL CHIP	1K 5% 1/16W
R3385	1-218-989-11	METAL CHIP	1M 5%	R5065	1-218-953-11	METAL CHIP	1K 5% 1/16W
R3386	1-218-946-11	METAL CHIP	270 5%	R5066	1-216-833-11	METAL CHIP	10K 5% 1/10W
R3401	1-234-371-21	RES, NETWORK 47X4 (1005)		R5067	1-218-953-11	METAL CHIP	1K 5% 1/16W
R3403	1-216-845-11	METAL CHIP	100K 5%	R5075	1-216-833-11	METAL CHIP	10K 5% 1/10W
R3404	1-216-845-11	METAL CHIP	100K 5%	R5077	1-216-829-11	METAL CHIP	4.7K 5% 1/10W
R3405	1-216-845-11	METAL CHIP	100K 5%	R5078	1-216-829-11	METAL CHIP	4.7K 5% 1/10W
				R5089	1-216-833-11	METAL CHIP	10K 5% 1/10W
				R5090	1-218-953-11	METAL CHIP	1K 5% 1/16W

(EXCEPT AEP)

Ref. No.	Part No.	Description	Remark	Ref. No.	Part No.	Description	Remark
R5091	1-218-953-11	METAL CHIP	1K 5% 1/16W	R7006	1-218-941-81	METAL CHIP	100 5% 1/16W
R5094	1-218-941-81	METAL CHIP	100 5% 1/16W	R7008	1-216-821-11	METAL CHIP	1K 5% 1/10W
R5095	1-218-941-81	METAL CHIP	100 5% 1/16W			(DZ640M/DZ840K/DZ840M/DZ940K)	
R5096	1-216-833-11	METAL CHIP	10K 5% 1/10W	R7009	1-218-285-11	METAL CHIP	75 5% 1/10W
R5097	1-218-941-81	METAL CHIP	100 5% 1/16W			(DZ640M/DZ840K/DZ840M/DZ940K)	
R5098	1-216-833-11	METAL CHIP	10K 5% 1/10W	R7010	1-218-285-11	METAL CHIP	75 5% 1/10W
R5099	1-216-833-11	METAL CHIP	10K 5% 1/10W			(DZ640M/DZ840K/DZ840M/DZ940K)	
R5102	1-218-941-81	METAL CHIP	100 5% 1/16W	R7012	1-218-285-11	METAL CHIP	75 5% 1/10W
R5103	1-218-941-81	METAL CHIP	100 5% 1/16W			(DZ640M/DZ840K/DZ840M/DZ940K)	
R5105	1-234-372-11	RES, NETWORK	100X4 (1005)	R7013	1-218-965-11	METAL CHIP	10K 5% 1/16W
R5111	1-218-959-11	METAL CHIP	3.3K 5% 1/16W	R7015	1-218-953-11	METAL CHIP	1K 5% 1/16W
			(DZ340M)	R7029	1-216-808-11	METAL CHIP	82 5% 1/10W
R5111	1-218-973-11	METAL CHIP	47K 5% 1/16W			(DZ640M/DZ840K/DZ840M/DZ940K)	
			(DZ640M/DZ840K/DZ840M/DZ940K)	R7029	1-218-285-11	METAL CHIP	75 5% 1/10W
R5112	1-218-963-11	METAL CHIP	6.8K 5% 1/16W			(DZ640M/DZ840K/DZ840M/DZ940K)	
			(DZ940K)			< NETWORK RESISTOR >	
R5112	1-218-967-11	METAL CHIP	15K 5% 1/16W				
			(DZ840M)	RB1103	1-234-371-21	RES, NETWORK	47X4 (1005)
R5112	1-218-969-11	METAL CHIP	22K 5% 1/16W	RB1104	1-234-371-21	RES, NETWORK	47X4 (1005)
			(DZ840K)	RB1105	1-234-371-21	RES, NETWORK	47X4 (1005)
R5112	1-218-973-11	METAL CHIP	47K 5% 1/16W	RB1106	1-234-371-21	RES, NETWORK	47X4 (1005)
			(DZ340M/DZ640M)	RB1109	1-234-371-21	RES, NETWORK	47X4 (1005)
R5201	1-216-833-11	METAL CHIP	10K 5% 1/10W	RB1110	1-234-371-21	RES, NETWORK	47X4 (1005)
R5203	1-218-973-11	METAL CHIP	47K 5% 1/16W	RB1111	1-234-371-21	RES, NETWORK	47X4 (1005)
R5301	1-216-809-11	METAL CHIP	100 5% 1/10W	RB1112	1-234-400-21	CONDUCTOR, NETWORK	0X4 (1005)
R5303	1-216-809-11	METAL CHIP	100 5% 1/10W	RB1113	1-234-400-21	CONDUCTOR, NETWORK	0X4 (1005)
R5307	1-234-372-11	RES, NETWORK	100X4 (1005)	RB1114	1-234-370-21	RES, NETWORK	22X4 (1005)
R5313	1-216-821-11	METAL CHIP	1K 5% 1/10W	RB1115	1-234-370-21	RES, NETWORK	22X4 (1005)
R5391	1-218-965-11	METAL CHIP	10K 5% 1/16W			< TERMINAL BOARD >	
			(AEP)				
R5555	1-218-953-11	METAL CHIP	1K 5% 1/16W				
			(PH, SP, TH)	TB3002	1-780-818-11	TERMINAL BOARD (SPEAKER)	2P (SPEAKERS (SUB L, SUB R))
R5555	1-218-959-11	METAL CHIP	3.3K 5% 1/16W				
			(AEP, E3, E15)	TB3901	1-780-884-11	TERMINAL BOARD (SPEAKER)	4P (SPEAKERS (FRONT L, FRONT R, CENTER, SUBWOOFER))
R5555	1-218-963-11	METAL CHIP	6.8K 5% 1/16W				
			(E12)			< VARISTOR >	
R5555	1-218-965-11	METAL CHIP	10K 5% 1/16W				
			(EA)	VDR102	1-805-774-21	VARISTOR, CHIP	
R5555	1-218-973-11	METAL CHIP	47K 5% 1/16W	VDR103	1-805-774-21	VARISTOR, CHIP	
			(DZ340M/DZ640M/DZ840M)			< VIBRATOR >	
R5556	1-218-955-11	METAL CHIP	1.5K 5% 1/16W				
			(DZ340M/DZ640M/DZ840M)	X1101	1-814-380-11	VIBRATOR, CRYSTAL	(27MHz)
R5556	1-218-973-11	METAL CHIP	47K 5% 1/16W	X3001	1-814-414-11	QUARTZ CRYSTAL UNIT	(24.576MHz)
			(AEP, E3, E12, E15, EA)	X5001	1-781-472-21	VIBRATOR, CERAMIC	(8MHz)
R5557	1-216-833-11	METAL CHIP	10K 5% 1/10W	X6001	1-814-414-11	QUARTZ CRYSTAL UNIT	(24.576MHz)
R6001	1-216-809-11	METAL CHIP	100 5% 1/10W			*****	
			(DZ840K/DZ840M/DZ940K)			MS-203 BOARD	
R6002	1-216-809-11	METAL CHIP	100 5% 1/10W			*****	
R6007	1-216-833-11	METAL CHIP	10K 5% 1/10W			< CONNECTOR >	
R6011	1-218-989-11	METAL CHIP	1M 5% 1/16W				
R6012	1-218-947-11	METAL CHIP	330 5% 1/16W				
R6016	1-216-864-11	SHORT CHIP	0 (DZ340M/DZ640M)	CN001	1-815-412-11	CONNECTOR, FFC/FPC	5P
R6027	1-234-371-21	RES, NETWORK	47X4 (1005)			< SWITCH >	
R6033	1-216-833-11	METAL CHIP	10K 5% 1/10W				
R6051	1-216-809-11	METAL CHIP	100 5% 1/10W				
			(DZ840K/DZ840M/DZ940K)	S001	1-786-693-11	SWITCH, DETECTION	(CHUCK/TRAY DETECT)
R6052	1-216-864-11	SHORT CHIP	0 (DZ340M/DZ640M)			*****	
R7001	1-218-827-11	METAL CHIP	150 0.5% 1/10W				
R7003	1-218-827-11	METAL CHIP	150 0.5% 1/10W				
			(DZ640M/DZ840K/DZ840M/DZ940K)				
R7004	1-218-827-11	METAL CHIP	150 0.5% 1/10W				
			(DZ640M/DZ840K/DZ840M/DZ940K)				
R7005	1-218-827-11	METAL CHIP	150 0.5% 1/10W				
			(DZ640M/DZ840K/DZ840M/DZ940K)				

HBD-DZ340M/DZ640M/DZ840K/DZ840M/DZ940K

PANEL

Ref. No.	Part No.	Description	Remark	Ref. No.	Part No.	Description	Remark
A-1804-404-A		PANEL BOARD, COMPLETE (DZ340M)				< CONNECTOR >	
A-1804-405-A		PANEL BOARD, COMPLETE (DZ840K)					
A-1804-407-A		PANEL BOARD, COMPLETE (DZ640M/DZ840M)		CN201	1-779-283-11	CONNECTOR, FFC (LIF (NON-ZIF)) 15P	
A-1804-408-A		PANEL BOARD, COMPLETE (DZ940K)		CN202	1-564-720-11	PIN, CONNECTOR (SMALL TYPE) 4P	
		*****		CN203	1-564-718-11	PIN, CONNECTOR (SMALL TYPE) 2P (DZ640M/DZ840K/DZ840M/DZ940K)	
		< CAPACITOR >				< DIODE >	
C201	1-100-909-11	CERAMIC CHIP	10uF 10% 6.3V	D201	6-502-961-01	DIODE DA2J10100L	
C202	1-114-323-11	CERAMIC CHIP	0.01uF 10% 50V	D202	6-500-848-01	DIODE MC2840-T112-1	
C203	1-162-964-11	CERAMIC CHIP	0.001uF 10% 50V	D203	6-502-469-01	LED SLI-325URT31WR (REC TO USB)	
C206	1-162-964-11	CERAMIC CHIP	0.001uF 10% 50V (DZ840K/DZ940K)	D204	6-501-579-01	DIODE MC2837	
C207	1-162-964-11	CERAMIC CHIP	0.001uF 10% 50V	D205	6-501-579-01	DIODE MC2837	
C208	1-162-964-11	CERAMIC CHIP	0.001uF 10% 50V	D206	6-503-085-01	LED SLD430WBD2PT31XN (VOLUME ILLUMINATION) (DZ940K)	
C209	1-165-908-11	CERAMIC CHIP	1uF 10% 10V	D207	6-502-963-01	DIODE DZ2J04700L	
C210	1-165-908-11	CERAMIC CHIP	1uF 10% 10V	D208	6-503-085-01	LED SLD430WBD2PT31XN (VOLUME ILLUMINATION) (DZ940K)	
C212	1-165-908-11	CERAMIC CHIP	1uF 10% 10V			< FERRITE BEAD >	
C213	1-126-791-11	ELECT	10uF 20% 35V (DZ840K/DZ940K)	FB201	1-500-236-22	BEAD, FERRITE (CHIP) (1608)	
C214	1-112-780-11	CERAMIC CHIP	0.47uF 10% 16V	FB202	1-500-236-22	BEAD, FERRITE (CHIP) (1608)	
C215	1-126-791-11	ELECT	10uF 20% 35V	FB203	1-500-236-22	BEAD, FERRITE (CHIP) (1608) (DZ840K/DZ940K)	
C216	1-165-908-11	CERAMIC CHIP	1uF 10% 10V			< IC >	
C219	1-162-923-11	CERAMIC CHIP	47PF 5% 50V	IC201	6-600-767-01	IC PNA4823M02S0 (IR)	
C220	1-126-791-11	ELECT	10uF 20% 35V	IC202	6-715-134-01	IC MM3404A33URE	
C221	1-164-315-11	CERAMIC CHIP	470PF 5% 50V	IC203	6-716-462-01	IC BD00GA3WEFJ-E2	
* C222	1-112-298-91	CERAMIC CHIP	1uF 10% 16V	IC204	6-713-989-01	IC NJM2783V(TE2)	
* C223	1-112-298-91	CERAMIC CHIP	1uF 10% 16V	IC205	8-759-100-96	IC uPC4558G2	
C224	1-162-960-11	CERAMIC CHIP	220PF 10% 50V (DZ840K/DZ940K)	IC206	6-701-729-01	IC PT6315	
C225	1-164-315-11	CERAMIC CHIP	470PF 5% 50V (DZ840K/DZ940K)			< JACK >	
C226	1-126-794-11	ELECT	4.7uF 20% 50V	J201	1-819-878-31	JACK (MIC 1) (DZ340M/DZ640M/DZ840M)	
C228	1-162-960-11	CERAMIC CHIP	220PF 10% 50V (DZ840K/DZ940K)	J201	1-819-878-31	JACK (MIC) (DZ840K/DZ940K)	
C229	1-126-791-11	ELECT	10uF 20% 35V	J202	1-819-878-31	JACK (MIC 2) (DZ340M/DZ640M/DZ840M)	
C230	1-114-325-11	CERAMIC CHIP	0.1uF 10% 25V	J202	1-819-878-31	JACK (AUDIO IN) (DZ840K/DZ940K)	
C232	1-126-382-11	ELECT	100uF 20% 16V (DZ840K/DZ940K)			< JUMPER RESISTOR >	
C233	1-114-325-11	CERAMIC CHIP	0.1uF 10% 25V	JR201	1-216-296-11	SHORT CHIP 0	
C234	1-114-325-11	CERAMIC CHIP	0.1uF 10% 25V	JR202	1-216-295-91	SHORT CHIP 0	
C235	1-126-791-11	ELECT	10uF 20% 35V	JR203	1-216-296-11	SHORT CHIP 0	
C236	1-114-325-11	CERAMIC CHIP	0.1uF 10% 25V	JR206	1-216-296-11	SHORT CHIP 0	
C237	1-126-791-11	ELECT	10uF 20% 35V (DZ840K/DZ940K)	JR208	1-216-296-11	SHORT CHIP 0	
C238	1-126-382-11	ELECT	100uF 20% 16V	JR210	1-216-296-11	SHORT CHIP 0	
C240	1-126-794-11	ELECT	4.7uF 20% 50V			< COIL >	
C241	1-126-382-11	ELECT	100uF 20% 16V	* L202	1-481-381-21	INDUCTOR 100uH	
C243	1-114-325-11	CERAMIC CHIP	0.1uF 10% 25V	L204	1-457-652-11	COIL, CHOKE 47uH	
C245	1-114-323-11	CERAMIC CHIP	0.01uF 10% 50V	L205	1-481-524-11	INDUCTOR 10uH	
C246	1-114-323-11	CERAMIC CHIP	0.01uF 10% 50V			< VACUUM FLUORESCENT DISPLAY >	
C247	1-114-324-11	CERAMIC CHIP	0.022uF 10% 50V	ND201	1-483-358-11	VACUUM FLUORESCENT DISPLAY	
C248	1-114-323-11	CERAMIC CHIP	0.01uF 10% 50V			< TRANSISTOR >	
C249	1-119-943-11	ELECT	47uF 20% 50V	Q201	8-729-027-50	TRANSISTOR DTC123JKA-T146 (DZ640M/DZ840K/DZ840M/DZ940K)	
C250	1-114-325-11	CERAMIC CHIP	0.1uF 10% 25V	Q202	8-729-038-37	TRANSISTOR RT1N141M-TP-1	
C252	1-114-325-11	CERAMIC CHIP	0.1uF 10% 25V (DZ940K)	Q203	6-552-713-01	TRANSISTOR QS5W2TR	
C253	1-114-325-11	CERAMIC CHIP	0.1uF 10% 25V (DZ940K)	Q204	8-729-038-37	TRANSISTOR RT1N141M-TP-1 (DZ940K)	
C254	1-100-909-11	CERAMIC CHIP	10uF 10% 6.3V				
C255	1-114-325-11	CERAMIC CHIP	0.1uF 10% 25V				
C258	1-162-974-11	CERAMIC CHIP	0.01uF 50V				

HBD-DZ340M/DZ640M/DZ840K/DZ840M/DZ940K

PANEL	POWER
-------	-------

Ref. No.	Part No.	Description	Remark	Ref. No.	Part No.	Description	Remark
		< RESISTOR >		R259	1-216-844-11	METAL CHIP 82K 5%	1/10W
R202	1-216-805-11	METAL CHIP 47	5% 1/10W			< SWITCH >	
R206	1-216-821-11	METAL CHIP 1K	5% 1/10W				
		(DZ640M/DZ840K/DZ840M/DZ940K)		S201	1-771-410-21	SWITCH, TACTILE (REC TO USB)	
R208	1-216-821-11	METAL CHIP 1K	5% 1/10W	S202	1-480-136-41	ENCODER, ROTARY (12 TYPE) (VOLUME)	
R209	1-216-845-11	METAL CHIP 100K	5% 1/10W			< TRANSFORMER >	
R210	1-216-821-11	METAL CHIP 1K	5% 1/10W				
R211	1-216-817-11	METAL CHIP 470	5% 1/10W	T201	1-445-998-11	TRANSFORMER, DC-DC CONVERTER	
R212	1-216-845-11	METAL CHIP 100K	5% 1/10W	*****			
R213	1-216-845-11	METAL CHIP 100K	5% 1/10W		A-1804-587-A	POWER BOARD, COMPLETE	
		(DZ840K/DZ940K)				(DZ340M/DZ640M/DZ840M)	
R214	1-216-817-11	METAL CHIP 470	5% 1/10W		A-1804-588-A	POWER BOARD, COMPLETE (PH, SP, TH)	
R215	1-216-817-11	METAL CHIP 470	5% 1/10W		A-1804-589-A	POWER BOARD, COMPLETE (AEP, EA)	
		(DZ840K/DZ940K)			A-1804-592-A	POWER BOARD, COMPLETE (E3, E12, E15)	
R216	1-216-813-11	METAL CHIP 220	5% 1/10W	*****			
R217	1-216-813-11	METAL CHIP 220	5% 1/10W		7-685-647-71	SCREW +BVTP 3X10 TYPE2 IT-3	
R218	1-216-813-11	METAL CHIP 220	5% 1/10W			< CAPACITOR >	
R219	1-216-813-11	METAL CHIP 220	5% 1/10W	△ C901	1-114-594-11	FILM 0.22uF 10%	250V
R220	1-218-871-11	METAL CHIP 10K	0.5% 1/10W	△ C902	1-114-594-11	FILM 0.22uF 10%	250V
R221	1-218-867-11	METAL CHIP 6.8K	0.5% 1/10W			(DZ340M/DZ640M/DZ840M)	
R222	1-218-887-11	METAL CHIP 47K	0.5% 1/10W	△ C902	1-116-397-21	FILM 0.33uF 10%	250V
R223	1-216-813-11	METAL CHIP 220	5% 1/10W			(AEP, EA)	
R224	1-216-813-11	METAL CHIP 220	5% 1/10W	△ C903	1-114-347-22	ELECT(BLOCK) 330uF 20%	450V
R226	1-216-833-11	METAL CHIP 10K	5% 1/10W	△ C905	1-116-393-11	FILM 0.0033uF 5%	400V
R227	1-216-821-11	METAL CHIP 1K	5% 1/10W	△ C906	1-117-815-11	FILM 1000PF 3%	1.5KV
R228	1-216-837-11	METAL CHIP 22K	5% 1/10W	C907	1-162-964-11	CERAMIC CHIP 0.001uF 10%	50V
R229	1-216-821-11	METAL CHIP 1K	5% 1/10W	C908	1-135-371-31	ELECT 56uF 20%	50V
		(DZ840K/DZ940K)		C909	1-162-960-11	CERAMIC CHIP 220PF 10%	50V
R230	1-216-821-11	METAL CHIP 1K	5% 1/10W	C910	1-126-965-91	ELECT 22uF 20%	50V
R230	1-216-864-11	SHORT CHIP 0	(DZ340M/DZ640M/DZ840M)			(EXCEPT AEP, EA)	
R231	1-216-837-11	METAL CHIP 22K	5% 1/10W	C910	1-126-967-11	ELECT 47uF 20%	50V
		(DZ840K/DZ940K)				(AEP, EA)	
R232	1-216-853-11	METAL CHIP 470K	5% 1/10W	C911	1-100-912-11	CERAMIC CHIP 1uF 10%	25V
R233	1-216-833-11	METAL CHIP 10K	5% 1/10W	C912	1-165-746-31	ELECT 22uF 20%	50V
R234	1-216-811-11	METAL CHIP 150	5% 1/10W	C916	1-100-912-11	CERAMIC CHIP 1uF 10%	25V
R235	1-216-835-11	METAL CHIP 15K	5% 1/10W	△ C918	1-112-871-51	CERAMIC 0.0022uF 20%	250V
R236	1-216-864-11	SHORT CHIP 0				(RU, AEP, EA)	
R238	1-216-821-11	METAL CHIP 1K	5% 1/10W	△ C920	1-112-871-51	CERAMIC 0.0022uF 20%	250V
		(DZ840K/DZ940K)				(RU, AEP, EA)	
R239	1-216-821-11	METAL CHIP 1K	5% 1/10W	△ C921	1-117-220-81	CERAMIC 150PF 5%	2KV
		(DZ840K/DZ940K)		C922	1-112-746-11	CERAMIC CHIP 4.7uF 10%	6.3V
R240	1-216-864-11	SHORT CHIP 0		C923	1-162-959-11	CERAMIC CHIP 330PF 5%	50V
R241	1-216-821-11	METAL CHIP 1K	5% 1/10W	△ C924	1-116-393-11	FILM 0.0033uF 5%	400V
R242	1-216-833-11	METAL CHIP 10K	5% 1/10W	C925	1-114-325-11	CERAMIC CHIP 0.1uF 10%	25V
R243	1-216-837-11	METAL CHIP 22K	5% 1/10W	△ C926	1-107-930-91	ELECT 22uF 20%	100V
R244	1-216-829-11	METAL CHIP 4.7K	5% 1/10W	C927	1-112-223-11	ELECT 3300uF 20%	10V
R245	1-216-829-11	METAL CHIP 4.7K	5% 1/10W	C928	1-112-229-11	ELECT 1500uF 20%	16V
R246	1-216-829-11	METAL CHIP 4.7K	5% 1/10W	C929	1-112-241-11	ELECT 1000uF 20%	25V
R247	1-216-829-11	METAL CHIP 4.7K	5% 1/10W	C932	1-114-994-11	ELECT 2200uF 20%	35V
R248	1-216-825-11	METAL CHIP 2.2K	5% 1/10W	C933	1-114-994-11	ELECT 2200uF 20%	35V
R251	1-216-811-11	METAL CHIP 150	5% 1/10W	C935	1-112-256-11	ELECT 1500uF 20%	35V
		(DZ940K)				(AEP, E3, E12, E15, EA)	
R252	1-216-833-11	METAL CHIP 10K	5% 1/10W	C935	1-116-856-11	ELECT 1000uF 20%	35V
R253	1-216-805-11	METAL CHIP 47	5% 1/10W			(RU, PH, SP, TH)	
R254	1-216-805-11	METAL CHIP 47	5% 1/10W	C936	1-114-323-11	CERAMIC CHIP 0.01uF 10%	50V
R255	1-216-811-11	METAL CHIP 150	5% 1/10W	C937	1-116-077-11	CERAMIC CHIP 0.047uF 10%	50V
		(DZ940K)		△ C938	1-112-869-51	CERAMIC 470PF 10%	250V
R256	1-216-809-11	METAL CHIP 100	5% 1/10W	C939	1-136-165-00	FILM 0.1uF 5%	50V
R257	1-216-809-11	METAL CHIP 100	5% 1/10W	C940	1-112-228-21	ELECT 1000uF 20%	16V
R258	1-216-809-11	METAL CHIP 100	5% 1/10W	C941	1-114-323-11	CERAMIC CHIP 0.01uF 10%	50V

HBD-DZ340M/DZ640M/DZ840K/DZ840M/DZ940K

POWER

Ref. No.	Part No.	Description	Remark	Ref. No.	Part No.	Description	Remark
C950	1-114-868-11	CERAMIC CHIP	0.1uF 10% 50V			< RESISTOR >	
C951	1-126-947-11	ELECT	47uF 20% 35V				
C952	1-126-947-11	ELECT	47uF 20% 35V				
C953	1-126-933-11	ELECT	100uF 20% 16V				
C955	1-126-933-11	ELECT	100uF 20% 16V			< IC >	
C956	1-126-923-91	ELECT	220uF 20% 10V				
△ C963	1-112-867-51	CERAMIC	220PF 10% 250V	△ IC901	6-707-742-01	IC STR-F6168-LF1352	
			(E3, E12, E15, PH, SP, TH)	△ IC921	6-714-671-01	IC STR-Y6763	
△ C963	1-112-869-51	CERAMIC	470PF 10% 250V	IC925	6-711-947-01	IC MM1431CURE	
			(RU, AEP, EA)	IC926	6-711-947-01	IC MM1431CURE	
△ C964	1-112-867-51	CERAMIC	220PF 10% 250V			< COIL >	
			(E3, E12, E15, PH, SP, TH)				
△ C964	1-112-869-51	CERAMIC	470PF 10% 250V	L932	1-457-796-11	COIL, AIR-CORE	
			(RU, AEP, EA)	L962	1-457-866-11	COIL, CHOKE 2.2uH	
				L963	1-457-866-11	COIL, CHOKE 2.2uH	
C970	1-114-325-11	CERAMIC CHIP	0.1uF 10% 25V	L964	1-400-791-21	INDUCTOR 10uH	
C971	1-114-325-11	CERAMIC CHIP	0.1uF 10% 25V	L965	1-400-793-21	INDUCTOR 47uH	
C981	1-162-968-11	CERAMIC CHIP	0.0047uF 10% 50V				
C983	1-116-077-11	CERAMIC CHIP	0.047uF 10% 50V	L966	1-400-791-21	INDUCTOR 10uH	
C984	1-114-323-11	CERAMIC CHIP	0.01uF 10% 50V			< LINE FILTER >	
C990	1-114-868-11	CERAMIC CHIP	0.1uF 10% 50V				
C991	1-114-868-11	CERAMIC CHIP	0.1uF 10% 50V	△ LF901	1-457-054-21	COIL, LINE FILTER	
C992	1-114-868-11	CERAMIC CHIP	0.1uF 10% 50V	△ LF902	1-457-054-21	COIL, LINE FILTER (RU, AEP, EA)	
C993	1-114-868-11	CERAMIC CHIP	0.1uF 10% 50V			< PHOTO COUPLER >	
△ C994	1-112-867-51	CERAMIC	220PF 10% 250V				
			(RU, AEP, EA)	△ PC901	6-600-276-01	PHOTO COUPLER PS2561AL1-1-V-W	
C998	1-114-322-11	CERAMIC CHIP	0.0047uF 10% 50V	△ PC902	6-600-276-01	PHOTO COUPLER PS2561AL1-1-V-W	
C999	1-162-964-11	CERAMIC CHIP	0.001uF 10% 50V	△ PC903	6-600-276-01	PHOTO COUPLER PS2561AL1-1-V-W	
						< TRANSISTOR >	
		< CONNECTOR >					
CN901	1-564-321-00	PIN, CONNECTOR (3.96mm PITCH) 2P		Q901	8-729-201-53	TRANSISTOR 2SA1015-GR	
CN902	1-785-102-11	PIN, CONNECTOR (3.96mm PITCH) 4P		Q923	8-729-056-46	TRANSISTOR 2SC5053T100Q	
* CN905	1-564-512-11	PLUG, CONNECTOR 9P		Q943	8-729-038-42	TRANSISTOR RT1N441M-TP-1	
				Q949	8-729-620-13	TRANSISTOR 2SC4154TP-1EF	
		< DIODE >		Q950	8-729-038-42	TRANSISTOR RT1N441M-TP-1	
△ D901	8-719-082-57	DIODE D5SBA60F01		Q969	6-551-699-01	TRANSISTOR ISA1602AM1-T111-1EF	
D904	6-502-961-01	DIODE DA2J10100L				< RESISTOR >	
D906	6-502-961-01	DIODE DA2J10100L					
D907	6-502-961-01	DIODE DA2J10100L		△ R901	1-240-938-91	METAL 1.5M 5% 1/2W F	
D908	6-502-961-01	DIODE DA2J10100L		△ R903	1-215-929-11	METAL OXIDE 100K 5% 3W F	
D909	6-502-961-01	DIODE DA2J10100L		△ R904	1-215-929-11	METAL OXIDE 100K 5% 3W F	
D910	6-502-961-01	DIODE DA2J10100L		R905	1-216-797-11	METAL CHIP 10 5% 1/10W	
△ D913	6-500-241-01	DIODE SARS03		R906	1-216-827-11	METAL CHIP 3.3K 5% 1/10W	
D914	6-502-961-01	DIODE DA2J10100L					
D931	6-501-849-01	DIODE FMX-22SL		R907	1-216-833-11	METAL CHIP 10K 5% 1/10W	
△ D943	8-719-080-53	DIODE RK36LF-B3		R908	1-216-829-11	METAL CHIP 4.7K 5% 1/10W	
△ D944	8-719-080-53	DIODE RK36LF-B3		R909	1-216-833-11	METAL CHIP 10K 5% 1/10W	
△ D945	8-719-080-59	DIODE EK19-V0		R910	1-216-825-11	METAL CHIP 2.2K 5% 1/10W	
D947	8-719-030-25	DIODE EG01CV0		R911	1-216-813-11	METAL CHIP 220 5% 1/10W	
△ D948	8-719-080-59	DIODE EK19-V0		△ R912	1-216-363-00	METAL OXIDE 0.33 5% 2W F	
				△ R914	1-220-891-11	METAL 0.1 10% 5W F	
D983	6-503-032-01	DIODE DZ2J180M0L		△ R916	1-215-929-11	METAL OXIDE 100K 5% 3W F	
D984	6-503-036-01	DIODE DZ2J220M0L		R917	1-216-829-11	METAL CHIP 4.7K 5% 1/10W	
D989	6-503-036-01	DIODE DZ2J220M0L		R919	1-216-837-11	METAL CHIP 22K 5% 1/10W	
D993	6-503-022-01	DIODE DZ2J100M0L					
D996	8-719-083-71	DIODE UDZSUSTE-1730B		△ R921	1-216-364-11	METAL OXIDE 0.39 5% 2W F	
				R923	1-218-879-11	METAL CHIP 22K 0.5% 1/10W	
		< FUSE >		R925	1-216-797-11	METAL CHIP 10 5% 1/10W	
△ F901	1-523-067-51	FUSE (T5AH/250V)		R926	1-218-847-11	METAL CHIP 1K 0.5% 1/10W	
				R931	1-218-851-11	METAL CHIP 1.5K 0.5% 1/10W	
		< IC LINK >					
△ F945	1-576-282-21	IC LINK (1.2A)		R932	1-218-879-11	METAL CHIP 22K 0.5% 1/10W	
△ F946	1-576-282-21	IC LINK (1.2A)		R933	1-216-821-11	METAL CHIP 1K 5% 1/10W	
				R934	1-216-821-11	METAL CHIP 1K 5% 1/10W	
				R935	1-216-821-11	METAL CHIP 1K 5% 1/10W	

Ref. No.	Part No.	Description	Remark	Ref. No.	Part No.	Description	Remark
R936	1-216-853-11	METAL CHIP 470K	5%	1/10W		MISCELLANEOUS	
R939	1-218-855-11	METAL CHIP 2.2K	0.5%	1/10W		*****	
R945	1-216-837-11	METAL CHIP 22K	5%	1/10W			
R946	1-216-827-11	METAL CHIP 3.3K	5%	1/10W			
R949	1-216-827-11	METAL CHIP 3.3K	5%	1/10W			
R951	1-218-875-11	METAL CHIP 15K	0.5%	1/10W			
R954	1-218-861-11	METAL CHIP 3.9K	0.5%	1/10W			
R955	1-216-821-11	METAL CHIP 1K	5%	1/10W			
R956	1-216-817-11	METAL CHIP 470	5%	1/10W			
R959	1-218-871-11	METAL CHIP 10K	0.5%	1/10W			
R963	1-218-839-11	METAL CHIP 470	0.5%	1/10W			
R965	1-218-863-11	METAL CHIP 4.7K	0.5%	1/10W			
R967	1-216-821-11	METAL CHIP 1K	5%	1/10W			
R976	1-216-833-11	METAL CHIP 10K	5%	1/10W			
R978	1-216-829-11	METAL CHIP 4.7K	5%	1/10W			
R992	1-216-793-11	METAL CHIP 4.7	5%	1/10W			
R993	1-216-809-11	METAL CHIP 100	5%	1/10W			
R998	1-218-855-11	METAL CHIP 2.2K	0.5%	1/10W			
R999	1-218-871-11	METAL CHIP 10K	0.5%	1/10W			
< TRANSFORMER >							
△ T901	1-443-874-11	TRANSFORMER, CONVERTER					
△ T903	1-445-320-11	TRANSFORMER, CONVERTER					
< THERMISTOR >							
△ TH901	1-811-194-21	POWER THERMISTOR 6.0					
< VARISTOR >							
△ VDR901	1-811-165-31	VARISTOR (TVR10471-D)					
△ VDR903	1-803-974-21	VARISTOR, CHIP (1608)					

	A-1804-423-A	POWER KEY BOARD, COMPLETE					

< CAPACITOR >							
C301	1-162-927-11	CERAMIC CHIP 100PF	5%	50V			
< CONNECTOR >							
* CN301	1-580-055-21	PIN, CONNECTOR (SMD) 2P					
< SWITCH >							
S301	1-798-284-11	SWITCH, TACTILE (I/⏻)					

	A-1804-412-A	USB BOARD, COMPLETE					

< CAPACITOR >							
C801	1-114-325-11	CERAMIC CHIP 0.1uF	10%	25V			
< CONNECTOR >							
CN801	1-822-423-11	CONNECTOR, USB (A) 4P (USB)					
CN802	1-564-707-11	PIN, CONNECTOR (SMALL TYPE) 5P					

Ref. No.	Part No.	Description	Remark
		MISCELLANEOUS	

104	1-835-400-21	CABLE, FLEXIBLE FLAT (15 CORE)	
152	1-832-572-21	CABLE, FLEXIBLE FLAT (13 CORE)	
△ 156	1-834-288-12	CORD, POWER (TH)	
△ 156	1-834-966-41	CORD, POWER-SUPPLY	
		(RU, AEP, E3, E15, PH, SP)	
△ 156	1-837-309-21	CORD, POWER-SUPPLY (EA)	
△ 156	1-839-012-11	CORD, POWER-SUPPLY (E12)	
204	1-832-539-21	CABLE, FLEXIBLE FLAT (5 CORE)	
△ 257	8-820-321-12	OPTICAL PICK-UP (KHM313CAA/C2RP1)	
258	1-838-443-11	FLEXIBLE FLAT CABLE 24P	
FAN3001	1-855-048-11	DC FAN (40mm)	



