

CD RECEIVER

# KDC-BT6544U/UY KDC-BT7043U KDC-BT742U SERVICE MANUAL

# KENWOOD

Kenwood Corporation

© 2009-1 PRINTED IN JAPAN  
B53-0698-00 (N) 429

Panel assy  
KDC-BT6544U/UY (A64-4736-02)

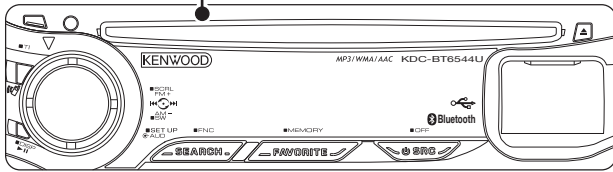

Panel assy  
KDC-BT7043U (A64-4738-02)

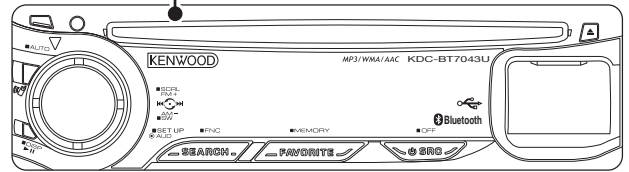

Panel assy  
KDC-BT742U (A64-4735-02)

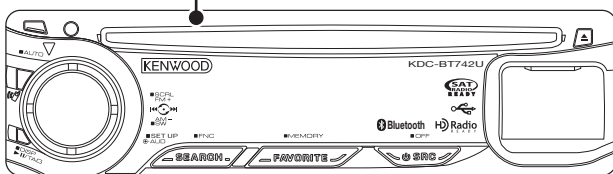

### TDF SPARE-PANEL

MAIN UNIT NAME	TDF PARTS No.	TDF NAME
KDC-BT6544U	Y33-3072-71	TDF-BT6544U
KDC-BT6544UY	Y33-3072-71	TDF-BT6544U
KDC-BT7043U	Y33-3070-21	TDF-BT7043U
KDC-BT742U	Y33-3070-10	TDF-BT97D

Mounting hardware assy  
(J22-0789-03)

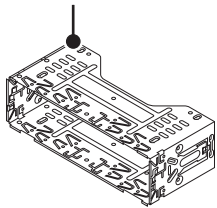

\* DC cord  
(E30-6428-05)

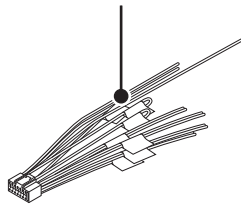

\* DC cord  
(E30-6671-05)

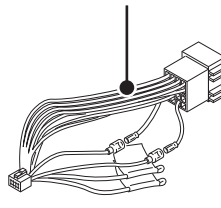

Remote controller assy (RC-547)  
(A70-2085-15)



Battery  
(Not supplied)

\* Screw (4x16)  
(N84-4016-48)



\* Screw set  
(N99-1757-15)



Lever  
(D10-7049-04) x2

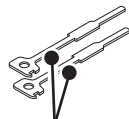

\* Plastic cabinet assy  
(A02-2755-23)

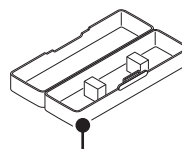

\* Escutcheon  
(B07-xxxx-xx)

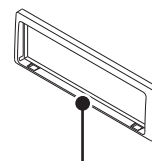

\* Carrying case  
(W01-1710-05)

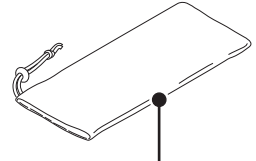

\* Depends on the model. Refer to the parts list.



This product uses Lead Free solder.  
This product complies with the **RoHS** directive for the European market.

**BLOCK DIAGRAM**

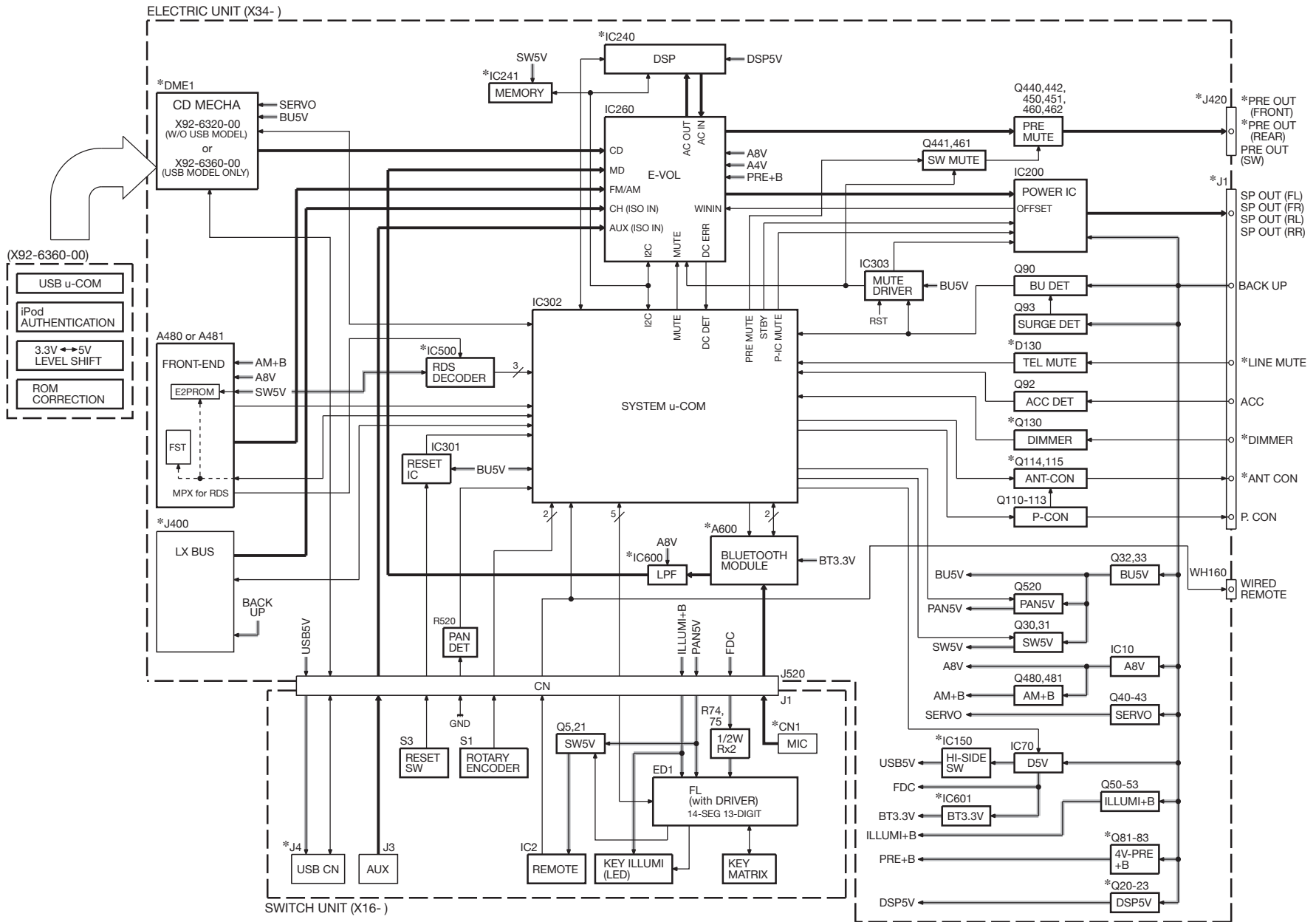

# BLOCK DIAGRAM

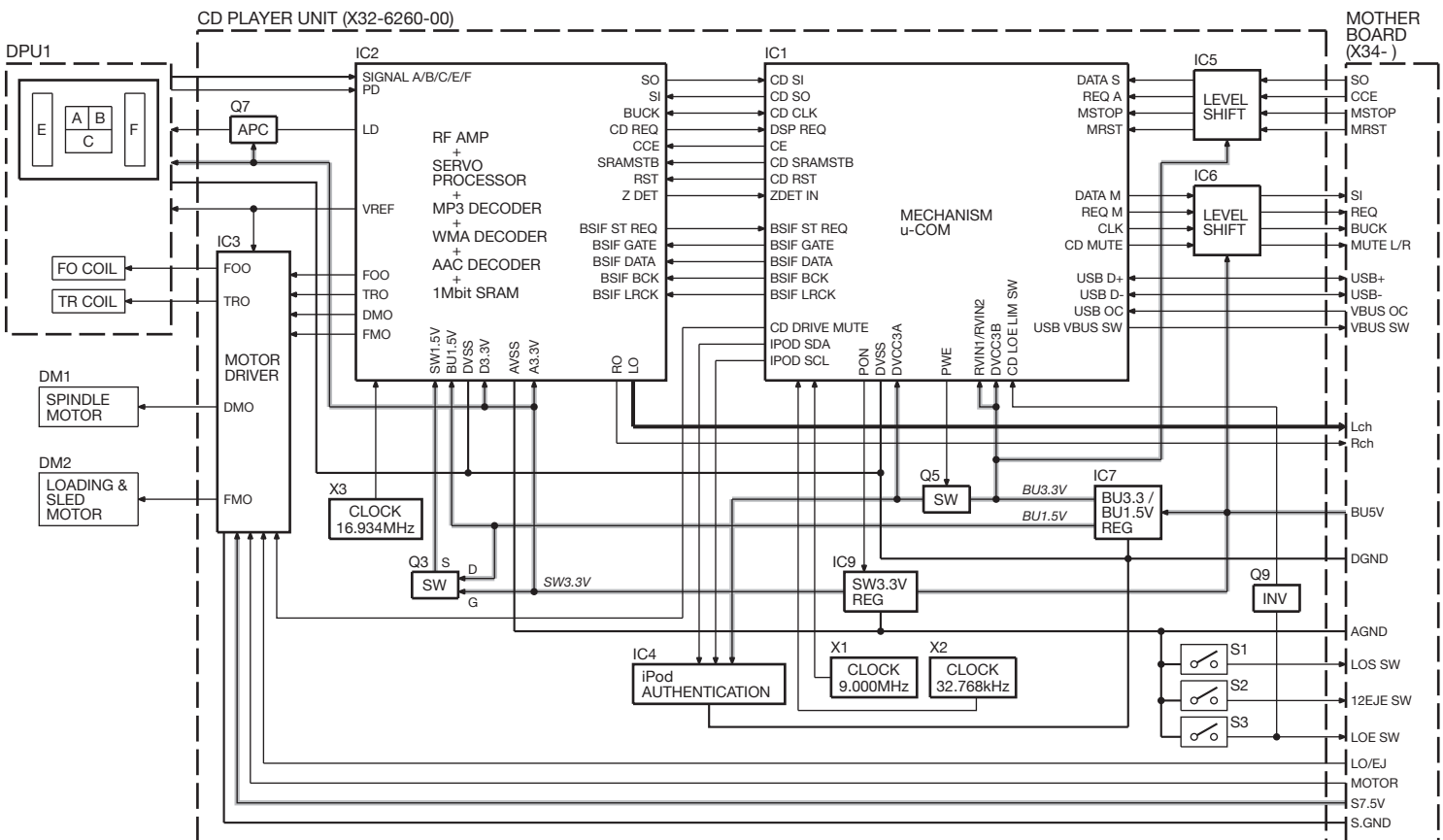

KDC-BT6544U/BT6544UY  
/BT7043U/BT742U

## COMPONENTS DESCRIPTION

### ● ELECTRIC UNIT (X34-629x-xx)

Ref. No.	Application / Function	Operation / Condition / Compatibility
IC10	Audio 8V REF / Power Supply	Outputs 1.27V.
IC70	Digital AVR for Panel & USB	Switching regulator for USB&VBUS and FDC (5V).
IC150	Power Control SW	USB power control switch with over current detection and protection.
IC200	Power IC	Amplifies front L/R and rear L/R.
IC240	DSP	Digital signal processor.
IC241	E2P Memory	DSP setting memory.
IC260	Source Selector & E-VOL	Selects analog source & full source volume. Analog source: AM/FM, CH, AUX. Digital source is selected by CD mecha. (CD/USB) Speaker-out "DC-offset" detection and protection. (This function consists of IC260 and IC200)
IC301	System $\mu$ -COM Reset Control	Outputs Lo (system $\mu$ -COM reset) when detection voltage goes below 3.6V.
IC302	System $\mu$ -COM	System control including power management, panel control, AM/FM/CH/SOC control, external control and etc.
IC303	Mute Logic	Controls logic for muting.
IC500	RDS & RBDS Decoder	
IC600	Bluetooth MIC Buffer	MIC signal differential amplifier.
IC601	Bluetooth Module 3.3V AVR	During active time, POWER is ON.
Q10~12	Audio 8V AVR	During active time, POWER is ON.
Q20~23	DSP5V AVR	When the base of Q23 goes Hi, DSP5V AVR is ON.
Q30,31	SW5V	During active time, POWER is ON.
Q32,33	BU5V AVR	During active time, POWER is ON.
Q40~43	Servo AVR	During active time, POWER is ON.
Q50~53	ILLUMI AVR	During active time, POWER is ON.
Q90	BU DET SW	Detects the backup voltage. If the backup is detected, it is ON.
Q92	ACC DET SW	Detects ACC voltage. If ACC is detected, it is ON.
Q93	Surge DET SW	Detects over-input voltage. If surge is detected, it is ON.
Q110~113	Power Control Output	When the base of Q110 goes Hi, power control output is ON. During active time, audio source is active.
Q114,115	Power ANT SW	During active time, tuner source is active.
Q130	Small Lamp DET SW	Detects small lamp. If small lamp is detected, it is ON.
Q170	Level Shift	System $\mu$ -COM (5V) $\leftrightarrow$ Bluetooth module (3.3V)
Q440	Preout Mute SW	Non-fader Lch
Q441	Preout Mute Driver	(Non-fader) When this transistor is ON, mute is active.
Q442	Preout Mute SW	Non-fader Rch
Q450	Preout Mute SW	Front Lch
Q451	Preout Mute SW	Front Rch
Q460	Preout Mute SW	Rear Lch
Q461	Preout Mute Driver	(F/R) When this transistor is ON, mute is active.
Q462	Preout Mute SW	Rear Rch
Q480,481	AM+B SW	During active time, AM source is active.
Q520	PAN5V SW	When the base goes Lo, PAN5V is ON.
Q601	Bluetooth Module Reset	When the base goes Hi, Bluetooth module is reset.

## COMPONENTS DESCRIPTION

### ● SWITCH UNIT (X16-6500-21)

Ref. No.	Application / Function	Operation / Condition / Compatibility
IC2	Remote Controller	Remote control receiver.
Q5	PAN5V	When the base goes Hi, PAN5V is supplied for IC2.
Q20	Key Scan Timing Adjustment	When the base goes Hi, key scan starts.
Q21	PAN5V	When the base of Q5 goes Hi, PAN5V is supplied for IC2.
Q22	Grid Reversing Driver	When the base goes Hi, GRID1 is ON.
Q23	Grid Reversing Driver	When the base goes Hi, GRID2 is ON.
Q24	Grid Reversing Driver	When the base goes Hi, GRID3 is ON.
Q51	Left Sub-ILLUMI Controller	When the base goes Hi, left sub-illumination is ON.
Q52	Center 3-key ILLUMI Controller	When the base goes Hi, center 3-key illuminations are ON.
Q53	Right Sub-ILLUMI Controller	When the base goes Hi, right sub-illuminations are ON.

### ● CD PLAYER UNIT (X32-6260-00)

Ref. No.	Application / Function	Operation / Condition / Compatibility
IC1	Mechanism $\mu$ -COM	Controls DSP and peripheral circuit. USB host controller. (Compliant with Universal Serial Bus Specification Rev2.0)
IC2	Servo DSP with Built-in Audio DAC	Built-in MP3-WMA-AAC decoder. Built-in 1M-bit-SRAM.
IC3	4ch BTL Driver	Driver for focusing & tracking coil, driver for sled & spindle motor, and operation for disc loading & ejection.
IC4	iPod Authentication	Connection authentication for iPod. MFI341S2162: iPhone-compliant.
IC5	3.3V $\rightarrow$ 5.0V Level Shift	Converts communication signal from 3.3V to 5.0V.
IC6	5.0V $\rightarrow$ 3.3V Level Shift	Converts communication signal from 5.0V to 3.3V.
IC7	BU1.5V / BU3.3V Regulator	Power supply for digital back-up. Power supply for mechanism $\mu$ -COM.
IC8	E2PROM	Memory for ROM correction. Countermeasure for software malfunction.
IC9	A3.3V Regulator	Power supply for digital, analog and audio line.
Q3	D1.5V Output	The output voltage in which the power supply that diverges from the BU1.5V line is turned on and off is used as D1.5V.
Q5	B.3.3V Output	The output voltage in which the power supply that diverges from the BU3.3V line is turned on and off is used as D3.3V.
Q6	Control signal Inverter	Controls Q5.
Q7	APC (Auto Power Control)	Laser diode driver.
Q9	Control signal Inverter	Because the detection logic of LOE/LIM_SW is different in the mechanism $\mu$ -COM and the system $\mu$ -COM, the logic to the mechanism $\mu$ -COM side is reversed.
D1	Laser Diode Protection	Prevents reverse bias which is applied to laser. Laser destruction prevention.
D2,3	Countermeasure against Static Electricity	The potential difference between DGND and AGND is absorbed, and the malfunction by static electricity is prevented.

## MICROCOMPUTER'S TERMINAL DESCRIPTION

### ● SYSTEM $\mu$ -COM: IC302 on X34- (ELECTRIC UNIT)

Pin No.	Pin Name	I/O	Application	Truth Value Table	Processing / Operation / Description
1	REMO	I	External remote control input and panel remote control input		
2	LX REQ M	O	Communication request to slave unit		
3	B SYS DATA	O	Serial output to Bolero		
4	B MECHA DATA	I	Serial input from Bolero		
5	B MECHA CLK	I	Serial clock input from Bolero		
6	BYTE	-			
7	CNVSS	-			
8	XCIN	-	Sub clock 32.768kHz		
9	XCOU	-	Sub clock 32.768kHz		
10	RESET	-			
11	XOUT	-	Main clock 12.00MHz		
12	VSS	-			
13	XIN	-	Main clock 12.00MHz		
14	VCC1	-			
15	NMI	-			
16	LX REQ S	I	Communication request from slave unit		
17	RDS CLK	I	RDS decoder clock input		(Terminal for European model)
18	PANEL DET	I	Panel connector detached/attached detection		H: Panel detached, L: Panel attached
19	PON AM	I/O	AM power supply control		AM operated: H, AM not operated: Hi-Z
20	TUN IFC OUT	I	Front-end IFC-OUT input		H: Station found, L: No station
21	RDS AFS M	I/O	Noise detection time constant SW		(Terminal for European model)
22	RDS QUAL	I/O	RDS decoder qualification input		(Terminal for European model)
23	RDS DATA	I	RDS decoder data input		(Terminal for European model)
24	V SYNC	-	Not used		Output L fixed
25	NC	-	Not used		Output L fixed
26	PWIC BEEP	O	Beep output		2kHz/1kHz (Model with Bluetooth)
27	TUN SCL	I/O	Front-end I2C clock input/output		MAX 400kHz
28	TUN SDA	I/O	Front-end I2C data input/output		
29	VFD DATA	I/O	VFD data input/output		
30	ROTARY CW	I	VOL key detection (Clockwise)		Detects pulse width TDF: 15-pulse/360°, 2-click/1-pulse
31	VFD CLK	O	VFD clock output		125kHz
32	VFD RST	O	VFD reset		H: Reset released, L: Reset Momentary power-down or panel detached or 11 minutes after ACC OFF: L
33	BT SYS DATA	O	Data output to Bluetooth		
34	BT BT DATA	I	Data input from Bluetooth		
35,36	NC	-	Not used		Output L fixed
37	PON D5V	I/O	SW-REG control		H: ON, Hi-Z: OFF
38	NC	-	Not used		Output L fixed
39	ROMCOR DET	I	E2PROM writing request		H: Writing
40	PDN	O	Simple DSP power down		H: ON, L: OFF
41	DFZ MUTE	I	Mute request from simple DSP		L: Mute request

## MICROCOMPUTER'S TERMINAL DESCRIPTION

Pin No.	Pin Name	I/O	Application	Truth Value Table	Processing / Operation / Description
42	ROTARY CCW	I	VOL key detection (Counterclockwise)		Detects pulse width TDF: 15-pulse/360°, 2-click/1-pulse
43	NC	-	Not used		Output L fixed
44	VFD CS	O	VFD control request		H: Possible to transfer VFD data
45	BT RST	O	Bluetooth module reset		L: Normal, H: Bluetooth reset
46	VFD INT	I	VFD-INT input		
47	NC	-	Not used		Output L fixed
48	PON PANEL	I/O	Panel 5V power supply control		ON (For 11 minutes after ACC OFF): L Momentary power-down or panel detached or 11 minutes after ACC OFF: Hi-Z
49	PON	O	Power supply control		H: Power supply ON, L: Power supply OFF
50	CD DISC12 SW	I	12cm disc detection		
51	CD LOS SW	I	CD loading detection		
52	MECHA STOP	O	SOC (System On Chip) stop		H: Normal, L: SOC stopped
52	CD PON	O	CD mechanism power supply control		H: ON, L: OFF
53	CD MUTE	I	CD Mute request		L: Mute request, H: Normal
54	S MECHA REQ	I	Communication request from mechanism to system μ-COM		
55	MECHA RST	O	SOC (System On Chip) reset		H: Normal, L: Reset
56	SRAMSTBY	O	Decoder SRAM standby control		H: SRAM standby
56	NC	-	Not used		Output L fixed
57	CD LOE LIM SW	I	CD detection (Chucking SW)		H: Loading completed, L: No disc
58	S SYS REQ	O	Communication request from system μ-COM to mechanism		
58	MDSP CE	O	Mechanism chip enable		
59	PON ILL	O	Key illumination power supply control		H: Power supply ON, L: Power supply OFF
60	VCC2	-			
61	DRV MUTE	O	CD motor driver mute output		
62	VSS	-			
63	TYPE 1	I	Destination SW		
64	TYPE 2	I	Destination SW		
65	NC	-	Not used		Output L fixed
66	CD LOEJ	I/O	CD motor control	①	Refer to the truth value table
67	CD MOTOR	O	CD motor control	①	Refer to the truth value table
68~70	NC	-	Not used		Output L fixed
71	ILLUMI DET	I	Dimmer illumination detection		L: ON, H: OFF
72	ACC DET	I	ACC power supply detection		ACC found: L, No ACC: H
73	BU DET	I	Momentary power-down detection		BU found: L, Momentary power down: H
74	ANT CON	O	Power antenna control		Tuner ON: H
75	PCON	O	External power amplifier control		
76	PWIC SVR	O	Power IC SVR discharge circuit control		H: ON, L: OFF
77	PWIC MUTE	O	Power IC mute control		
78	PWIC STBY	O	Power IC standby control		
79	LINE MUTE	I	Line mute detection		TEL mute: Below 1V, NAVI mute: Over 2.5V

## MICROCOMPUTER'S TERMINAL DESCRIPTION

Pin No.	Pin Name	I/O	Application	Truth Value Table	Processing / Operation / Description
80	ST DC DET	I	Wrong connection detection		
81	E2P SDA	I/O	E2PROM I2C data input/output		
82	E2P SCL	I/O	E2PROM I2C clock input/output		
83	DC DET	I	DC offset detection		
84	MUTE AFS	I/O	AFS mute		L: Mute ON, Hi-Z: Mute OFF
85	MUTE 0	O	E-VOL Front mute		L: ON, H: OFF
86	MUTE 1	O	E-VOL Rear mute		L: ON, H: OFF
87	MUTE 2	O	E-VOL Sub Woofer mute		L: ON, H: OFF
88	MUTE PRE FR	O	PRE-OUT mute Front/Rear		Lo when mute is Lo (CD played). Momentary power-down: L H fixed only when Dual Zone is ON.
89	MUTE PRE SW	O	PRE-OUT mute SW (Sub Woofer) * For both PRE-OUT Rear selected and SW selected.		L: Mute, H: Mute OFF Lo when mute is Lo (CD played). Momentary power-down: L
90	RDS NOISE	I	FM noise detection		(Terminal for European model)
91	TUN SMETER	I	S-meter input		
92	LX MUTE	I	Mute request from slave unit		H: Mute ON, L: Mute OFF
93	LX CON	O	Start-up request to slave unit		H: Slave unit ON , L: Slave unit OFF
94	AVSS	-			
95	LX RST	O	Forced reset to slave unit		H: Reset, L: Normal
96	VREF	-			
97	AVCC	-			
98	LX DATA S	I	Data from slave unit		
99	LX DATA M	O	Data to slave unit		
100	LX CLK	I/O	LX-BUS clock		

### • Truth value table

① CD motor control

	CD motor	CD loading/eject
Stop	L	L
Load	H	L
Eject	H	H
Brake	H	Hi-z



# TEST MODE

## ■ Display description

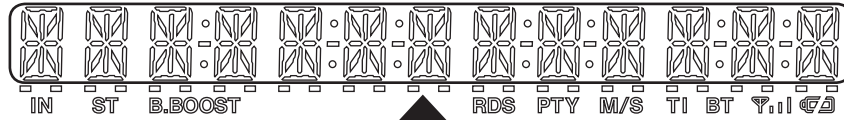

Key	Description of display	Description

A symbol “■” in the key column indicates that the key should be pressed and held for 1 second or longer.

## ■ Key layout



## ■ How to enter the test mode

Procedure	Note
Reset while [SEARCH] and [SRC] keys are being pressed.	While “----” is displayed, power can be turned ON.

All lamps blink when it is detected that the sub-clock resonator is disconnected.

When having started up in the test mode, change the LINE MUTE inhibition time from 10 seconds to 1 second.

When operating in the test mode, even if a DC offset error occurs, detection information is not written in the E2PROM.

When operating in the test mode, CD mechanism error log information clear mode, and DC offset error detection information clear mode, do not perform DEMO mode operations.

Also, do not display DEMO ON/OFF option items in the MENU in STANDBY source in the above modes.

In the test mode the forced disc ejection is prohibited to shorten the period of activation during the test mode transition operation.

## ■ How to clear the test mode

Procedure	Note
Reset, momentary power down, ACC OFF, POWER OFF, Panel detached.	Clearing the test mode

## ■ Test mode default condition

Description	Default values
Source	STANDBY
Display	Display lights are all turned on.
Volume	-10dB (“30” is displayed.)
Bass Boost	OFF
CRSC	OFF regardless of having/not having the switching function.
AUX	ON1

# TEST MODE

Description	Default values
System Q/dB EQ	NATURAL (FLAT)
Simple DSP	STANDBY (FLAT)
Simple DSP	BYPASS (Set up the path that does not go through the DSP)
Beep	Goes on (i.e., beeps) when the key is pressed briefly
Preout	Rear

## ■ Test mode specification in Standby source

Key	Description of display	Description	
Common	All lights ON. <div style="display: flex; justify-content: space-around; font-family: monospace; font-size: 0.8em;"> <span>[ ] [ ] [ ] ÷ [ ] [ ] ÷ [ ] [ ] ÷ [ ] [ ] ÷ [ ] [ ]</span> </div>	All lights ON. * Red dot lines also go ON.	
FM	ROM correction version display		
	System μ-com      Mecha μ-com		
	S : R 0 0 0 1 M : R 0 0 0 1	Figures are ROM correction version number.	
	S : E R R    M : E R R	In the case when E2PROM is not installed.	
	S : R - - - M : R - - -	In the case when correction data is not yet written.	
	S : R * * * * M : R * * * *	In the case when the correction data is incompatible (Version of data is incompatible)	
▶▶	Audio data initialization <div style="font-family: monospace; font-size: 0.8em;">A U D I O    I N I T   </div>	AUDIO setting value is re-set to the test mode default value.	
◀◀	Forced Power OFF information display	P O F F    - - -	No forced power OFF
		P O F F    P N L	Forced power OFF by communication error between system μ-com and panel.
■◀◀		While the forced power OFF data is displayed, press and hold for 2 seconds to clear the data.	
AUD	Information display	[ ] i P o d : [ ] [ ] [ ] [ ] [ ] [ ] [ ] [ ]	iPod authentication IC installation condition display.
	iPod authentication IC installation status display	[ ] i P o d : O K [ ] [ ] [ ] [ ] [ ] [ ] [ ] [ ]	Blank: Checking if the IC is installed OK: IC is being installed, NG: IC is not yet installed
		[ ] i P o d : N G [ ] [ ] [ ] [ ] [ ] [ ] [ ] [ ]	(Press the key while the display is what is shown in the left column to return to the normal display)
▶	CD information display mode	Move to CD information display mode (sub-mode)	* Refer to “CD information display mode” for the contents and operation of the display.
■▶	ON/OFF	Clear entire CD information	While in CD information display mode, press and hold for 2 seconds or longer to clear all CD information.
SEARCH	FNC operation	Multi-function operation (Normal operation)	
FAV	Version & service information display	Move to Version and service information display (Sub-mode)	* Refer to “Version and service information display” for the contents and operation of the display.

# TEST MODE

• **Version and service information display (Sub-mode)**

\* When “Version and service information display” is selected, “Destination terminal condition display” will be opened as default display.

Key		Description of display		Description
FM (forward) ↑ ↓ AM (reverse)		Destination terminal condition indication	T Y P E 2 : 1 □ T Y P E 1 : 1	“TYPE” indicates system μ-com (IC302) destination, and shows real-time condition of the destination terminal.
		Development ID condition indication	C 0 8 5 7 W E 2 □ - 3 . 0 0	Development ID – Version (system μ-com: IC302)
		Serial No. display	S N O □ □ 0 0 0 0 0 0 0 0	Serial No. is displayed (8 digits)
	■ FAV	Power ON time display	P O N T I M □ □ □ 0 H X X	00~50 is displayed for “XX”. When less than 1 hour, displayed by increments of 10 minutes.
			P O N T I M □ □ X X X X X X	00001~10922 is displayed for “XXXXX”. MAX 10922 (hours)
	■ FAV	Disc operation time display	C D T I M □ □ □ □ 0 H X X	00~50 is displayed for “XX”. When less than 1 hour, displayed by increments of 10 minutes.
			C D T I M □ □ □ X X X X X X	00001~10922 is displayed for “XXXXX”. MAX 10922 (hours)
	■ FAV	Disc EJECT times display	E J E C T □ □ X X X X X X	Disc EJECT times display. MAX 65535 (times)
			E J E C T □ □ X X X X X X	While disc EJECT times is displayed, press and hold for 2 seconds or longer to clear disc EJECT times.
	■ FAV	Panel open/close times display	P N C N T □ □ □ X X X X X X	PANEL open/close times display. MAX 65535 (times)
P N C N T □ □ □ X X X X X X			Press the key for more than 2 seconds while the PANEL open/close count is displayed and PANEL open/close count is cleared.	

# TEST MODE

• CD information display mode (Sub-mode)

Key	Description of display	Description
FM (forward) ↑ ↓ AM (reverse)	◀◀/ ▶▶ CD mecha- nism error log display	M E C H A □ E R R 1 □ : X X Mechanism error log 1 (Latest) XX: Error number. "--" is displayed in case there is no error.
		M E C H A □ E R R 2 □ : X X Mechanism error log 2 (Latest) XX: Error number. "--" is displayed in case there is no error.
		M E C H A □ E R R 3 □ : X X Mechanism error log 3 (Latest) XX: Error number. "--" is displayed in case there is no error.
	◀◀/ ▶▶ CD Load error information display	L O A D □ □ E R R 1 □ : X X Load error switch 1 XX: Number of errors. "--" is displayed in case there is no error.
		L O A D □ □ E R R 2 □ : X X Load error switch 2 XX: Number of errors. "--" is displayed in case there is no error.
	◀◀/ ▶▶ CD Ejec- tion error information display	E J E C T □ E R R 1 □ : X X Ejection error switch 1 XX: Number of errors. "--" is displayed in case there is no error.
		E J E C T □ E R R 2 □ : X X Ejection error switch 2 XX: Number of errors. "--" is displayed in case there is no error.
		E J E C T □ E R R 3 □ : X X Ejection error switch 3 XX: Number of errors. "--" is displayed in case there is no error.
		E J E C T □ E R R 4 □ : X X Ejection error switch 4 XX: Number of errors. "--" is displayed in case there is no error.
	◀◀/ ▶▶ CD time code error count data display (Missing counts)	C N T □ L O S E □ □ □ □ CD time code error count data (Missing counts) mode display.
		C D D A □ □ □ □ □ □ : X X Number of CD-DA count errors XX: Number of errors. "--" is displayed in case there is no error.
		C D R O M □ □ □ □ □ □ : X X CD-ROM (Compressed file) number of count errors XX: Number of errors. "--" is displayed in case there is no error.
◀◀/ ▶▶ CD time code error count data display (count not updated)	C N T □ S T A Y □ □ □ □ CD time code error count data (count not updated) mode display.	
	C D D A □ □ □ □ □ □ : X X Number of CD-DA count errors XX: Number of errors. "--" is displayed in case there is no error.	
	C D R O M □ □ □ □ □ □ : X X CD-ROM (Compressed file) number of count errors XX: Number of errors. "--" is displayed in case there is no error.	

# TEST MODE

## ■ Test mode specifications in TUNER source

Error is found in front-end (A1), etc. if indications below is displayed while in tuner source.

Status	Display	Description
Front-end (A48x) E2PROM data error	T N E 2 P N G	Front-end (A48x) E2PROM is still the default (unspecified) value.
Front-end (A48x) communication error	T N C O N N G	Communication with front-end (A48x) is not possible.
Destination mismatch	T N T Y P N G	When destination is mismatch between front-end (A48x) E2PROM and the product.

## • TUNER preset operation

Key	Display	Description
■ FAV	Preset function F M # 9 8 . 3 A : 4	Change to 98.3MHz.

## • K3I forced switching

Every time when [FAV] key is pressed in tuner FM source, switched in the following order: AUTO → Forced WIDE → Forced MIDDLE → Forced NARROW → AUTO. Default status is AUTO, and displayed as shown below.

Key	Display	Description	
FAV	K3I Forced switching	F M 1 9 8 . 1 A :	AUTO
		F M 1 9 8 . 1 W :	Forced WIDE
		F M 1 9 8 . 1 M :	Forced MIDDLE
		F M 1 9 8 . 1 N :	Forced NARROW

## • RDS automatic measurement (Only models with RDS)

Add this measurement instead of the visual inspection of PS display that has been used in the production line.

Status	Display	Description
PS data reception	F M 1 R D S T E S T :	When the display is what is shown in the left column, forcibly turn off. P-CON returns when the power is turned off/on (POWER OFF/ON).

## TEST MODE

### • FST adjustment mode

Perform FST soft-mute adjustment.

Key	Note
■▶II	To enter into FST adjustment mode (Press and hold the key for 1 second) In FM, the frequency changes to 98.3MHz

Operations in the FST adjustment mode are as follows:

Key	Description of display		Description
FM (UP) ↑	◀◀/▶▶	Soft-mute adjustment [S] [M] [D] [-] [F] [ ] [ ] [ ] [ ] [ ] [ ] [ ] [ ] [ ] [ ]	0 ↔ 7
		Seek Stop Level adjustment (Auto) [A] [T] [N] [ ] [ ] [ ] [ ] [ ] [V] [ ] [ ] [ ] [ ] [ ] [ ] [ ]	0.00 (V) ↔ 5.00 (V). Normal (Local OFF)
AM (DOWN) ↓		Seek Stop Level adjustment (Auto) [A] [T] [L] [ ] [ ] [ ] [ ] [ ] [V] [ ] [ ] [ ] [ ] [ ] [ ] [ ]	0.00 (V) ↔ 5.00 (V). Normal (Local ON)
	◀◀/▶▶	Seek Stop Level adjustment (Manual) [M] [N] [N] [ ] [ ] [ ] [ ] [ ] [V] [ ] [ ] [ ] [ ] [ ] [ ] [ ]	0.00 (V) ↔ 5.00 (V). Normal (Local OFF)
	◀◀/▶▶	Seek Stop Level adjustment (Manual) [M] [N] [L] [ ] [ ] [ ] [ ] [ ] [V] [ ] [ ] [ ] [ ] [ ] [ ] [ ]	0.00 (V) ↔ 5.00 (V). Normal (Local ON)
■▶II		Adjustment value memory [E] [P] [ ] [W] [R] [I] [T] [E] [ ] [ ] [ ] [ ] [ ] [ ] [ ] [ ]	Displays the data that has been written in the E2PROM when pressing the key for 2 seconds or longer.
▶II		Mode clear [F] [M] [1] [ ] [ ] [ ] [ ] [ ] [9] [8] [.] [3] [A] [ ] [ ] [ ] [ ] [ ] [4]	Clear the FST adjustment mode. (Returns to normal display and the test mode is retained.)

Switch Local Seek ON or OFF by briefly pressing [TEL/AUTO/TI] key when the Local Seek ON/OFF switching is allowed in the band.

After completing the FST adjustment, if you wish to clear the test mode, you can do this using the reset button.

# TEST MODE

## ■ Test mode specifications in CD source

Display mode default: P-Time

### • Procedure in CD-DA media (KTD-02A)

Key	Display		Description
▶▶	Track up procedure		Every time pressed, jumps to the track shown below. No.9 → No.15 → No.10 → No.11 → No.12 → No.13 → No.22 → No.14 → No.9 (recursive) But in case the disc has 8 tracks or less, playback starts with track No.1. (For both CD-DA and compressed file discs)
◀◀	Track down procedure		Goes down by 1 track from the currently played track.
FAV	Jump operation and Mechanism version display	Jump operation and Mechanism version display (Sub-mode)	* Refer to “Jump operation and Mechanism version display” for contents and operation of the display.
TEL/TI/ AUTO	Jump operation	Jump operation * Toggling of jumping between tracks No. 9 and No. 22 (No.9 ↔ No.22)	Jump to No. 9 when the track of No. 22 is being played back. Jump to No. 22 when the track of No. 9 is being played back.

### • Jump operation and Mechanism version display (Sub-mode)

\* When operating the jump operation of the track while the mechanism information in this sub-mode, the track number is displayed for the specific period of time (prior to any other information) and then the mechanism information is displayed again.

Key	Display		Description
FM	Jump operation	This operation is operational only in the “Jump operation and Mechanism version display” during CD source.	Jump to No. 28. (Scratch 0.7mm for MUSIC line vibration testing)
AM	Jump operation	This operation is operational only in the “Jump operation and Mechanism version display” during CD source.	Jump to No. 14. (Disc whose surface is not perfectly flat: TCD-731RA Tr14)
FAV	Information display Mechanism μ-com version	□ 9 □ B □ 3 □ 0 : □ □ □ □ □ □ □ □	Display of Mechanism model name and Mechanism version (Pressing the key while the indication in the left cell is shown is to change to the mechanism servo version display.)
	Information display Mechanism servo version	□ S □ E □ R □ V : □ □ □ □ □ □ □ □	Mechanism servo table version display (Pressing the key while the indication in the left cell is shown is to change to the mechanism boot program version display.)
	Information display Mechanism boot program version	□ B □ O □ O □ T : □ □ □ □ □ □ □ □	Mechanism boot program version display (Pressing the key while the indication in the left cell is shown is to change to the normal display.)
TEL/TI/ AUTO	Jump operation	This operation is operational only in the “Jump operation and Mechanism version display” during CD source.	Jump to No.15. Set the volume value to 25. (For 20Hz 0dB DC protection error operation FCT checking)

### • Operations with the compressed media

Key	Display		Description
	File format display (MP3)	□ M □ P □ 3 □ □ □ □ □ □ □ □ □ □	Display file format just before the start of file playback.
	File format display (WMA)	□ W □ M □ A □ □ □ □ □ □ □ □ □ □	
	File format display (AAC)	□ A □ A □ C □ □ □ □ □ □ □ □ □ □	

## TEST MODE

### ■ Audio-related test mode

Procedure	Note
■ TEL/TI/AUTO	Enter the audio adjustment mode (The default items shown are different from model with DSP to model without DSP) [Model with DSP] (Destination “K” and “E”) When DUAL ZONE is ON: BYPASS→DUAL ZONE→FADER→BALANCE→R-VOLUME→V-OFFSET When DUAL ZONE is OFF: BYPASS→DUAL ZONE→FADER→BALANCE→SUB-W→V-OFFSET [Model without DSP] (Destination “M”) When DUAL ZONE is ON: DUAL ZONE→FADER→BALANCE→BASS→MID→TRE→R-VOLUME→B.BOOST→USER→HPF-F→HPF-R→V-OFFSET When DUAL ZONE is OFF: DUAL ZONE→FADER→BALANCE→BASS→MID→TRE→SUB-W→B.BOOST→USER→HPF-F→HPF-R→LPF-SW→V-OFFSET

About audio adjustment items (include both Audio Function Mode and Audio Setup Mode)

Procedure	Item	Procedure	Description
For item forwarding procedure, press [AUD] key and [FM] key	BYPASS *1 (Only in model with DSP)	[VOL] knob and [◀◀ / ▶▶] key	BYPASS ↔ THROUGH (Default value: BYPASS)
	Dual Zone	[VOL] knob and [◀◀ / ▶▶] key	Adjust to 2 steps of OFF ↔ ON. (Default value: OFF)
	Fader	[VOL] knob and [◀◀ / ▶▶] key	Adjust to 3 steps of R15 ↔ 0 ↔ F15. (Default value: 0)
	Balance	[VOL] knob and [◀◀ / ▶▶] key	Adjust to 3 steps of L15 ↔ 0 ↔ R15. (Default value: 0)
	R-VOLUME	[VOL] knob and [◀◀ / ▶▶] key	Adjust to 2 steps of 0 ↔ 35. (Default value: 35)
	Bass Level	[VOL] knob and [◀◀ / ▶▶] key	Adjust to 3 steps of -8 ↔ 0 ↔ +8. (Default value 0)
	Middle Level	[VOL] knob and [◀◀ / ▶▶] key	Adjust to 3 steps of -8 ↔ 0 ↔ +8. (Default value 0)
	Treble Level	[VOL] knob and [◀◀ / ▶▶] key	Adjust to 3 steps of -8 ↔ 0 ↔ +8. (Default value 0)
	HPF Front (KDC-BT7043U only)	[VOL] knob and [◀◀ / ▶▶] key	Adjust to 2 steps of Through ↔ 180Hz. (Default value: Through)
	HPF Rear (KDC-BT7043U only)	[VOL] knob and [◀◀ / ▶▶] key	Adjust to 2 steps of Through ↔ 180Hz. (Default value: Through)
For item forwarding procedure, press [AUD] key and [FM] key	LPF Subwoofer	[VOL] knob and [◀◀ / ▶▶] key	Adjust to 2 steps of 60Hz ↔ Through. (Default value: Through)
	LPF Subwoofer Phase (KDC-BT7043U only)	[VOL] knob and [◀◀ / ▶▶] key	Adjust to 2 steps of Normal ↔ Reverse. (Default value: Normal)
	Volume Offset	[VOL] knob and [◀◀ / ▶▶] key	Adjust to 2 steps of -8 ↔ 0. (Default value 0)
	Bass BOOST	[VOL] knob and [◀◀ / ▶▶] key	Adjust to 2 steps of OFF ↔ ON. (Default value OFF)

\*1: Display the settings for “BYPASS ON/OFF” in the AUDIO adjustment mode of the test mode to enable the selection operation. These settings are same as the BYPASS settings of DSP setting in the multi-function.

### ■ [ATT] key operation

Procedure	Note
Press [▶  ] key briefly in the Tuner source.	ATT OFF/ON

### ■ MENU-related test mode

\* In the TUNER source, run the unit in the normal operation (PRESET call operation) mode.

Procedure	Note
Press [SEARCH] key briefly (Unit itself) Press [DNPP/SBF] key and [DIRECT] key briefly (Remote controller)	Continuous forwarding by remote control is prohibited



# TEST MODE

## ■ Backup current measurement

Procedure	Note
While ACC OFF (Back Up ON), Reset	MUTE terminal is OFF after 2 seconds, not after 15 seconds. (During this time, the CD mechanism does not function.)

## ■ Switching of Preout

Procedure	Note
Press and hold [TEL/TI/AUTO] key in the Standby source	Switching PREOUT (1 Preout / 2 Preout model)

## ■ Clearing of CD mechanism information, Service information, DC offset error information, BT memory information, and FAVORITE registration information. (Clear the data recorded in FLASH MEMORY of E2PROM and BT module)

Status	Display	Description
Resetting while [TEL/TI/AUTO] + [FAV] is being pressed	<input type="checkbox"/> C <input type="checkbox"/> D <input type="checkbox"/> <input type="checkbox"/> <input type="checkbox"/> <input type="checkbox"/> <input type="checkbox"/> <input type="checkbox"/> <input type="checkbox"/> <input type="checkbox"/> <input type="checkbox"/> <input type="checkbox"/> <input type="checkbox"/> <input type="checkbox"/> <input type="checkbox"/> <input type="checkbox"/> <input type="checkbox"/>	At normal termination
	<input type="checkbox"/> C <input type="checkbox"/> D <input type="checkbox"/> <input checked="" type="checkbox"/> X <input type="checkbox"/> <input type="checkbox"/> <input type="checkbox"/> <input type="checkbox"/> <input type="checkbox"/> <input type="checkbox"/> <input type="checkbox"/> <input type="checkbox"/> <input type="checkbox"/> <input type="checkbox"/> <input type="checkbox"/> <input type="checkbox"/> <input type="checkbox"/>	At abnormal termination

While “---” is displayed, power can be ON. This mode is cancelled by resetting. (The last screen will not be retained.)

Data to be cleared is shown below.

Information to be cleared	Details of information	Data recorded in
CD mechanism information	CD mechanism error log display	E2PROM
	Displays CD loading error data	E2PROM
	Displays CD EJECT error data	E2PROM
	Displays CD time code count error data (missing count)	E2PROM
	Displays CD time code count error data (count not updated)	E2PROM
Service Information	Power ON time display	E2PROM
	CD operation time display	E2PROM
	CD EJECT times display	E2PROM
	PANEL open/close times display	E2PROM
	Forced Power OFF information display	E2PROM
DC offset error information	DC offset error 1 display (Provides information on whether there is an improper connection or another error)	E2PROM
	DC offset error 2 display (Provides information on the number of capacitor leaks)	E2PROM
BT memory information	Pairing information	FLASH memory in BT module
	Preset phone number information	E2PROM
	Friendly name (Setting)	FLASH memory in BT module
	PIN code	FLASH memory in BT module
FAVORITE registration information	FAVORITE registration information (Registration list) * Total 10 items	E2PROM

## TEST MODE

### ■ Clearing DC offset error detection data (E2PROM data clearing)

Procedure	Note
Resetting while [PLAY/PAUSE] + [FAV] is being pressed	Entering DC offset error display mode.

While “----” is displayed, power can be ON.

Even if the DC offset error detection is running, it shall be possible to move to this condition.

This mode is cleared when the unit is reset. (The last status is not held)

Procedure	Display	Description
Initial display	D C □ □ E R R □ □ □ □ □ □ □ □	When DC offset error is detected (when either one of capacitors is leaking, or an improper connection or another error is detected)
	D C □ □ O K □ □ □ □ □ □ □ □	When DC offset error is not detected (when none of capacitors leak, no improper connection or other error is detected)
SEARCH	D C 1 □ E R R □ □ □ □ □ □ □ □	When improper connection or other DC offset errors are detected.
	D C 1 □ O K □ □ □ □ □ □ □ □	When improper connection or other DC offset errors are not detected.
■ SEARCH	D C 1 □ O K □ □ □ □ □ □ □ □	When detecting improper connection or other DC offset errors, clears detection data. (Clear E2PROM)
FAV	D C 2 □ 4 □ □ □ □ □ □ □ □ □ □	When detecting capacitor leak, provides information on the number of capacitor leaks. (0~4)
■ FAV	D C 2 □ 0 □ □ □ □ □ □ □ □ □ □	When detecting capacitor leak, clears the number of capacitor leaks. (Clear E2PROM)

This mode is cancelled by resetting. (The last screen will not be retained.)

### ■ FM/AM channel space switching (Only for models of destination “K” and “M”)

Procedure	Note
While Power OFF, press and hold [TEL/TI/AUTO] key and [SEARCH] key, and press [SRC] key to Power ON	FM200kHz/AM10kHz ↔ FM50kHz/AM9kHz FM50kHz/AM10kHz ↔ FM200kHz/AM10kHz

### ■ Security

#### • Method to clear the security code

Procedure	Display	Description
Press and hold [▶▶] key for 3 seconds while [TEL/TI/AUTO] key is being pressed	C O D E □ - - - □ □ □ □ □ □ □ □	Carry out the procedure while “----” is being displayed.
	C O D E □ □ □ □ □ □ □ □ □ □	“----” disappears.
Press the remote control key 5 twice to display “K” and then press [▶▶] key.	C O D E □ K □ □ □ □ □ □ □ □	
Press the remote control key 2 three times to display “C” and then press [▶▶] key.	C O D E □ K C □ □ □ □ □ □ □ □	
Press the remote control key 2 once to display “A” and then press [▶▶] key.	C O D E □ K C A □ □ □ □ □ □ □ □	
Press the remote control key 7 twice to display “R” and then press [▶▶] key.	C O D E □ K C A R □ □ □ □ □ □ □ □	
	A P P R O V E D □ □ □ □ □ □ □ □	Security cancelled. (If wrong character is input, code request mode is displayed.)

# TEST MODE

## ■ ROM data transfer

\* This function is shown in the MENU only when the source is STANDBY and thus in reality it is operational only in the case of STANDBY source.

Procedure	Display	Description
While pressing and holding [SEARCH] key and [SRC] keys, reset-start	□ □ □ □ □ □ □ □ □ □ □ □ □ □	All lights ON.
Press [SEARCH] key (MENU)	R O M □ R E A D □ □ □ □ □ □	MENU mode
Press [◀◀] key or [▶▶] key	R O M □ R E A D □ □ □ □ □ □	Front-end (A48x) → Mother unit (X34-). Data transfer processing.
	R O M □ W R I T E □ □ □ □ □ □	Mother unit (X34-) → Front-end (A48x). Data transfer processing.
(In the above ROM READ status), ■ [▶▶] key (2 seconds)	R O M □ R E A D □ □ □ □ □ □	Front-end (A48x) → Mother unit (X34-). ROM data is being transferred.
	R O M □ R E A D □ □ O K □ □	Front-end (A48x) → Mother unit (X34-). ROM correction transfer, security and other data is OK.
	R O M □ R E A D □ □ O K 2 □	Front-end (A48x) → Mother unit (X34-). Transfer of security and other data is OK.
	R O M □ R E A D □ □ N G □ □	Front-end (A48x) → Mother unit (X34-). ROM data transfer is NG.
(In the above ROM WRT status), ■ [▶▶] key (2 seconds)	R O M □ W R I T E □ □ □ □ □ □	Mother unit (X34-) → Front-end (A48x). ROM data is being transferred.
	R O M □ W R I T E □ □ O K □ □	Mother unit (X34-) → Front-end (A48x). ROM correction, security and other data transfer is OK.
	R O M □ W R I T E □ □ O K 1 □	Mother unit (X34-) → Front-end (A48x). ROM correction data transfer is OK.
	R O M □ W R I T E □ □ O K 2 □	Mother unit (X34-) → Front-end (A48x). Transfer of security and other data is OK.
	R O M □ W R I T E □ □ N G □ □	Mother unit (X34-) → Front-end (A48x). ROM data transfer is NG
(In every status of ROM data transfer processing), press [SEARCH] key	□ □ □ □ □ □ □ □ □ □ □ □ □ □	Clear from ROM correction data transfer processing

This function is used, in case of front-end (A48x) failure, to transfer E2PROM data (ROM correction, security and other data) inside of the front-end (A48x) to E2PROM (IC300) of the data saving mother unit (X34-), and this function is also used, after the replacement of the front-end (A48x), to transfer the data that have been saved in the E2PROM (IC300) of the data saving mother unit (X34-) to the new front-end (A48x).

Refer to the following “ROM Data Transfer Process” pages for the details of security and other data”.

## ROM DATA TRANSFER PROCESSES

When replacing front-end (A48x) of mother unit (X34-), or when adding or replacing ROM correction (program correction with ROM IC (IC300)), the following activities are required.

### ■ Overview

When replacing front-end (A48x) in the model where ROM correction and security data have been written into E2PROM, included in the front-end (A48x) pack, the transfer function of the E2PROM data itself in the replaced front-end (A48x) is required.

This function in the above system configuration is used to allow for complete replacement of the front-end at any service center.

### ■ Overview of specifications

Procedures for replacement are as follows: To install the E2PROM (IC300) BR24L04FV-W to the mother unit (X34-), and replace front-end (A48x) with new front-end after copying the data in the E2PROM (IC300) (such as ROM correction data and other data) in the front-end (A48x) to the mother unit (X34-) by operating the system, and then copy the data (such as ROM correction data and other data) into the mother unit to the E2PROM of the front-end (A48x), operating the main body.

Tuner adjustment data was inserted during the tuner pack manufacturing, and data will not be transferred because front-end (A48x) is built-in.

In addition, tuner adjustment data for new front-end (A48x) is supplied as a service part in which data was inserted.

### ■ Data to be copied

- ROM correction data
- Other data
  - Security data
  - DEMO MODE ON/OFF status
  - POWER ON time (For maintenance)
  - Playback time (For maintenance)
  - EJECT count (For maintenance)
  - Panel open/close count (For maintenance)
  - CD I2C status (For maintenance)
  - CD offset error code (For maintenance)
  - CD sound skips count (For maintenance)
  - CD time code not updated count (For maintenance)
  - CD load switch errors count (For maintenance)
  - CD ejection errors count (For maintenance)
  - DC offset error (For maintenance)

- Forced Power OFF information (For maintenance)
- Serial number (For maintenance)
- E2PROM data check data (For internal check)

### ■ Operation procedure

Operation procedure is different depending on the conditions. Proceed with the appropriate operation procedure depending on the specific condition.

1. In case of replacing front-end (A48x) without an applicable ROM correction.
2. In case of replacing front-end (A48x) with an applicable ROM correction.
3. In case of applying new ROM correction at the same time when front-end (A48x) is replaced. (No ROM correction has been carried out.)

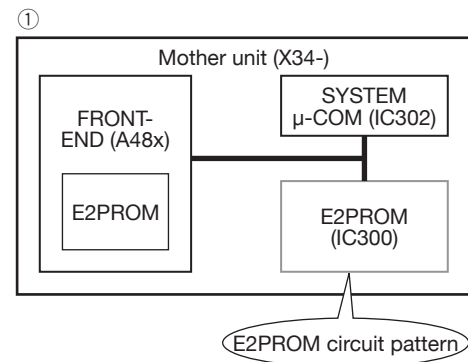

- Install new E2PROM (IC300) BR24L04FV-W.  
Install E2PROM (IC300) containing no data, in case of [1] and [2].  
In case of [3], install maintenance E2PROM with an applicable ROM correction program.

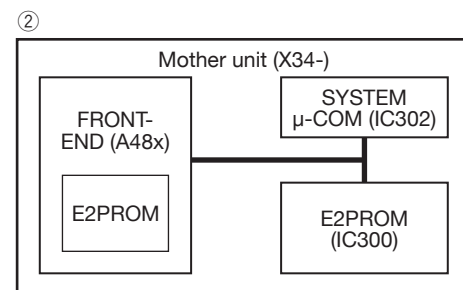

# ROM DATA TRANSFER PROCESSES

Turn power on.  
 Press and hold the [1] and [3] keys and press reset button.  
 (Enter the system in the test mode.)  
 Press [B.BOOST] key. (ROM data System enters data transfer mode.)  
 Press [◀◀] (or ▶▶) . (Select READ)  
 Press [▶] key for 1 second or longer. (Data transfer)

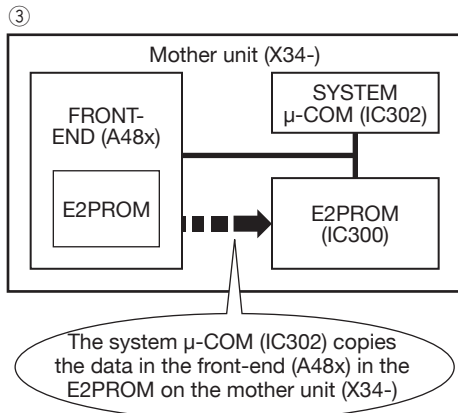

In case of [2]  
 READ OK R-OK

In case of [1] or [3]  
 READ OK2 R-O2



Press [▶] key. (Exit ROM data transfer mode.)  
 Turn power off.  
 Remove front-end (A48x).

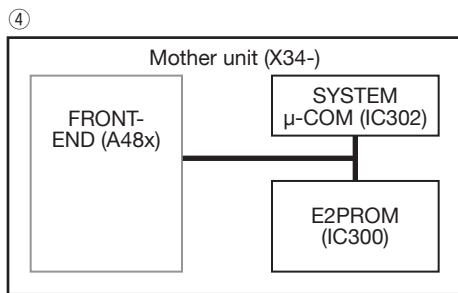

Install new front-end (A48x).  
 No ROM correction or other data status.

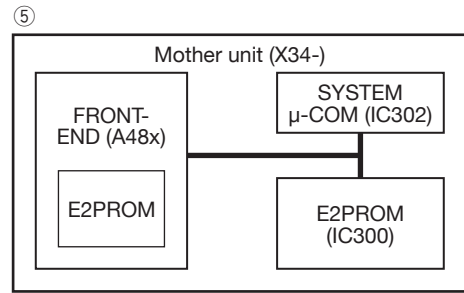

Turn power on.  
 Press and hold the [1] and [3] keys and press reset button.  
 (Enter the system in the test mode.)  
 Press [B.BOOST] key. (Start transferring ROM data.)  
 Press [◀◀] (or ▶▶) . (Select WRT)  
 Press [▶] key for 1 second or longer. (Data transfer)

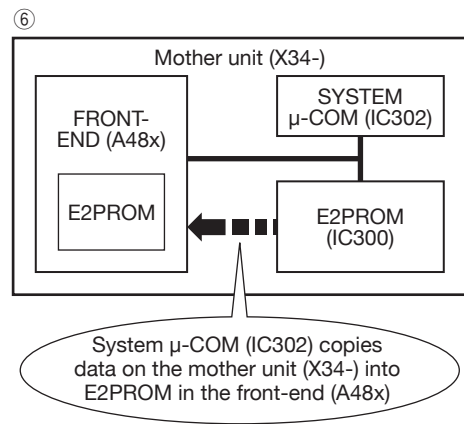

In case of [2] or [3]  
 WRT OK W-OK

In case of [1]  
 WRT OK2 W-O2

Press [▶] key. (Exit ROM data transfer mode.)

## ROM DATA TRANSFER PROCESSES

4. In case of applying a new ROM correction when front-end (A48x) is replaced (There is ROM correction data.)
5. In case of applying a new ROM correction even when front-end (A48x) is not replaced.

Turn power on.

Press and hold the [1] and [3] keys, press reset button. (Enter the system in the test mode.)

Press [B.BOOST] key. (ROM data System enters data transfer mode.)

Press [◀◀] (or ▶▶) . (Select WRT)

Press [▶▶] key for 1 second or longer. (Data transfer)

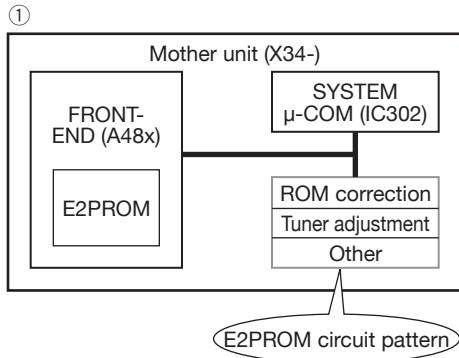

Install new E2PROM. (E2PROM that has been updated with ROM correction)

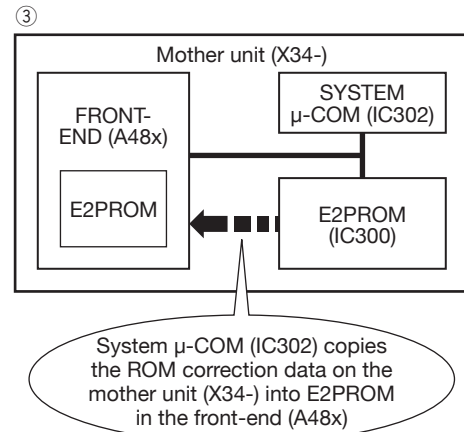
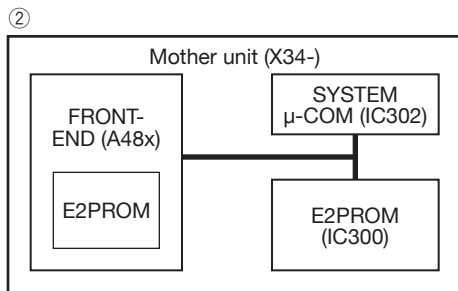

In case of [4]

In case of [5]

Press [▶▶] key. (Exit ROM data transfer mode.)

Press [◀◀] (or ▶▶) . (Select READ)

Press [▶▶] key for 1 second or longer. (Data transfer)

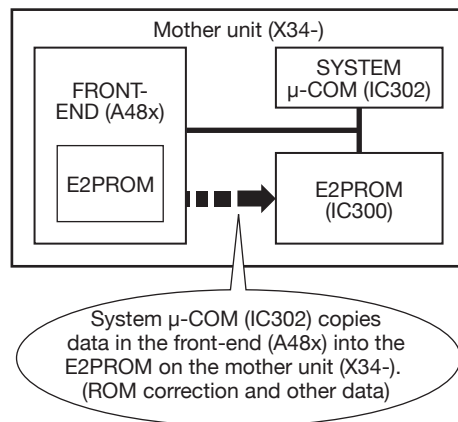

# ROM DATA TRANSFER PROCESSES

Press [▶|] key. (Exit ROM data transfer mode.)  
Turn power off.

Remove front-end (A48x).

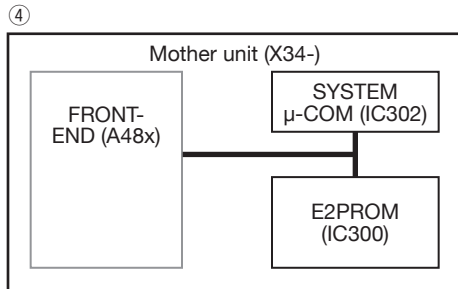

Install new front-end (A48x).  
No ROM correction or other data status.

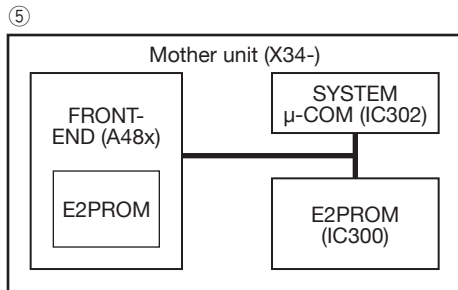

Turn power on.  
Press and hold the [1] and [3] keys press reset button. (Enter the system in the test mode.)  
Press [B.BOOST] key. (Enter the system in ROM data transfer mode.)  
Press [◀◀] (or [▶▶] .) (Select WRT)  
Press [▶|] key for 1 second or longer. (Data transfer)

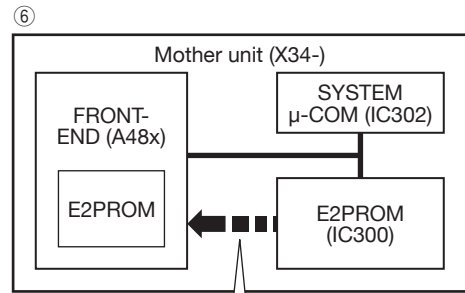

Press [▶|] key. (Exit ROM data transfer mode.)

## INSTALLER MEMORY SPECIFICATIONS

At specialists (or specialty stores), when the installer sends the vehicle back to the user, they may make the store-recommended audio configuration.

When the user changes the setting values, when the backup power supply was taken out at times of battery change or when the reset button was pressed, to make it possible to recall the setting values, the store-recommended configuration values can be saved into E2PROM.

The specification detail defer in “with-DSP model” and in “without-DSP model”.

### [Models without DSP]

- Calling and saving the configuration is done by the MENU.
- Items to be saved are Bass, Middle, Treble, X'over, and Sub Woofer Level. Only one setting can be saved for each item (Bass/Middle/Treble settings can be changed for each source, but only one setting can be saved as the installer memory specification, and the source in which the saving operation was carried out is saved as such).
- The contents read out by the call key shall be reflected only to the current source at the time→EQ curve is “USER” (Bass/Middle/Treble settings can be changed for each source, but not reflected to Bass/Middle/Treble settings of sources other than where the calling operation was carried out).
- When the backup power supply was taken out at times of battery change or when the reset button was pressed, as the initial setting values of Bass, Middle, Treble, X'over, and Sub Woofer Level, the saved memory is reflected. (Bass/Middle/Treble setting initial setting value memory is reflected in all sources.)

**[NOTE]** By such, EQ curve initial setting shall always be “USER” (NOT “NATURAL” or “FLAT”).

## BACKUP MEMORY SPECIFICATIONS

Settings by the user other than the installer memory items are saved into the E2PROM, and when the backup power supply was taken out at times of battery change or when the reset button was pressed, it is made possible to recall the setting values saved.

- While Power ON, the memory is saved and accumulated at a certain interval (temporary).
- Items to be saved into the memory are: Volume Offset (for all sources) and preset frequencies (FM/AM all bands x 6 channels).
- When the backup power supply was taken out at times of battery change or when the reset button was pressed, as the initial setting values of Volume Offset (for all sources) and preset frequencies (FM/AM all bands x 6 channels), the saved memory is reflected.
- In models which includes channel space switching, when channel space is switched, TUNER-preset frequencies are set back to the default values.



# PC BOARD (COMPONENT SIDE VIEW)

# PC BOARD (FOIL SIDE VIEW)

SWITCH UNIT  
X16-6500-21 (J76-0568-02)

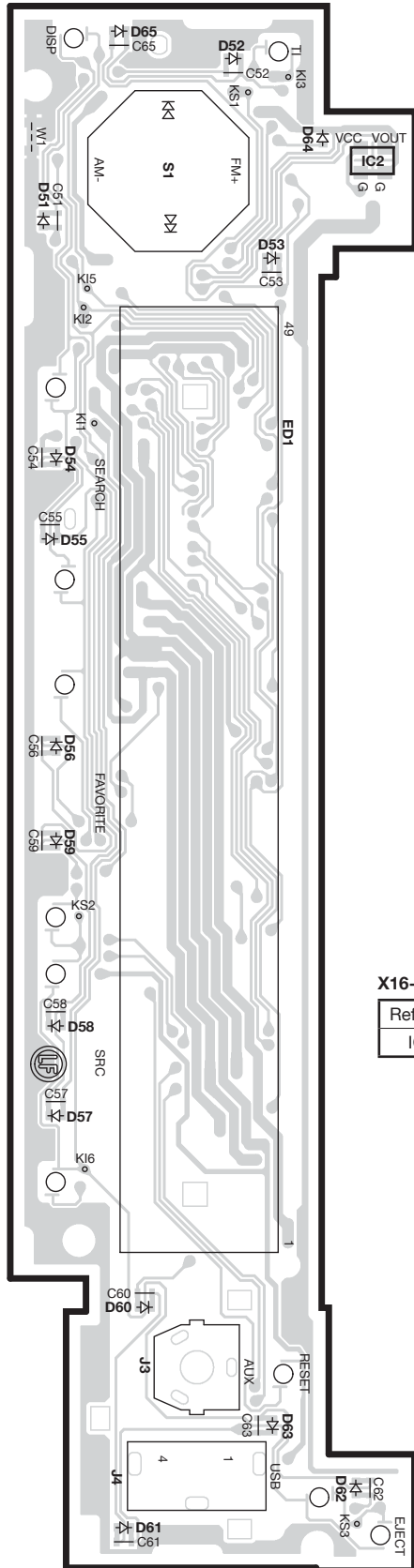

X16-6500-21

Ref. No.	Address
IC2	2B

SWITCH UNIT  
X16-6500-21 (J76-0568-02)

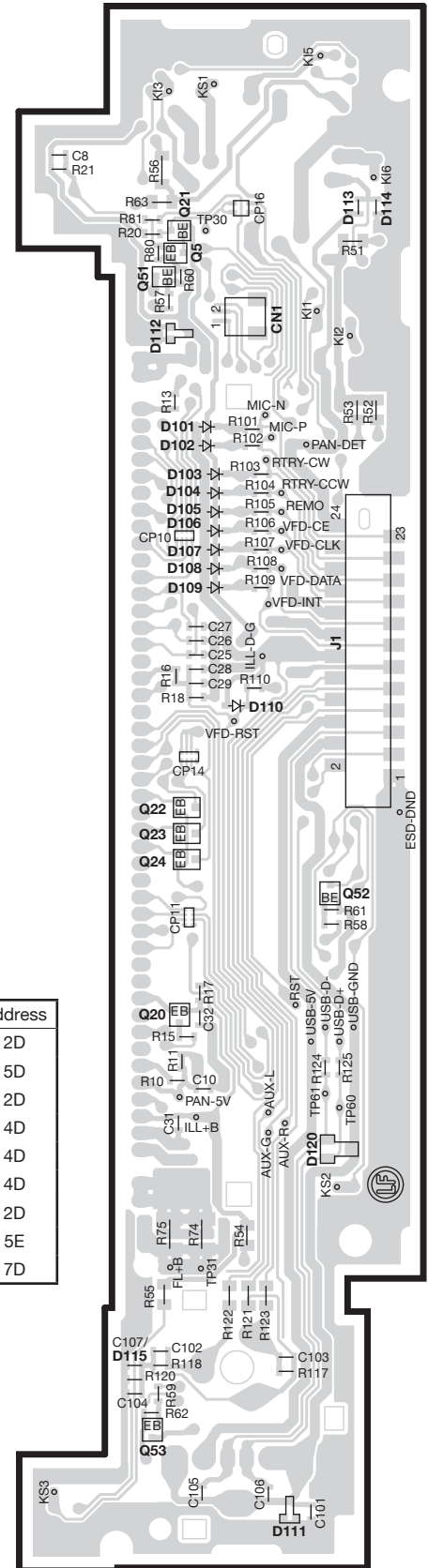

X16-6500-21

Ref. No.	Address
Q5	2D
Q20	5D
Q21	2D
Q22	4D
Q23	4D
Q24	4D
Q51	2D
Q52	5E
Q53	7D

Refer to the schematic diagram for the values of resistors and capacitors.

# PC BOARD (COMPONENT SIDE VIEW)

ELECTRIC UNIT X34-629x-xx (J76-0567-02)

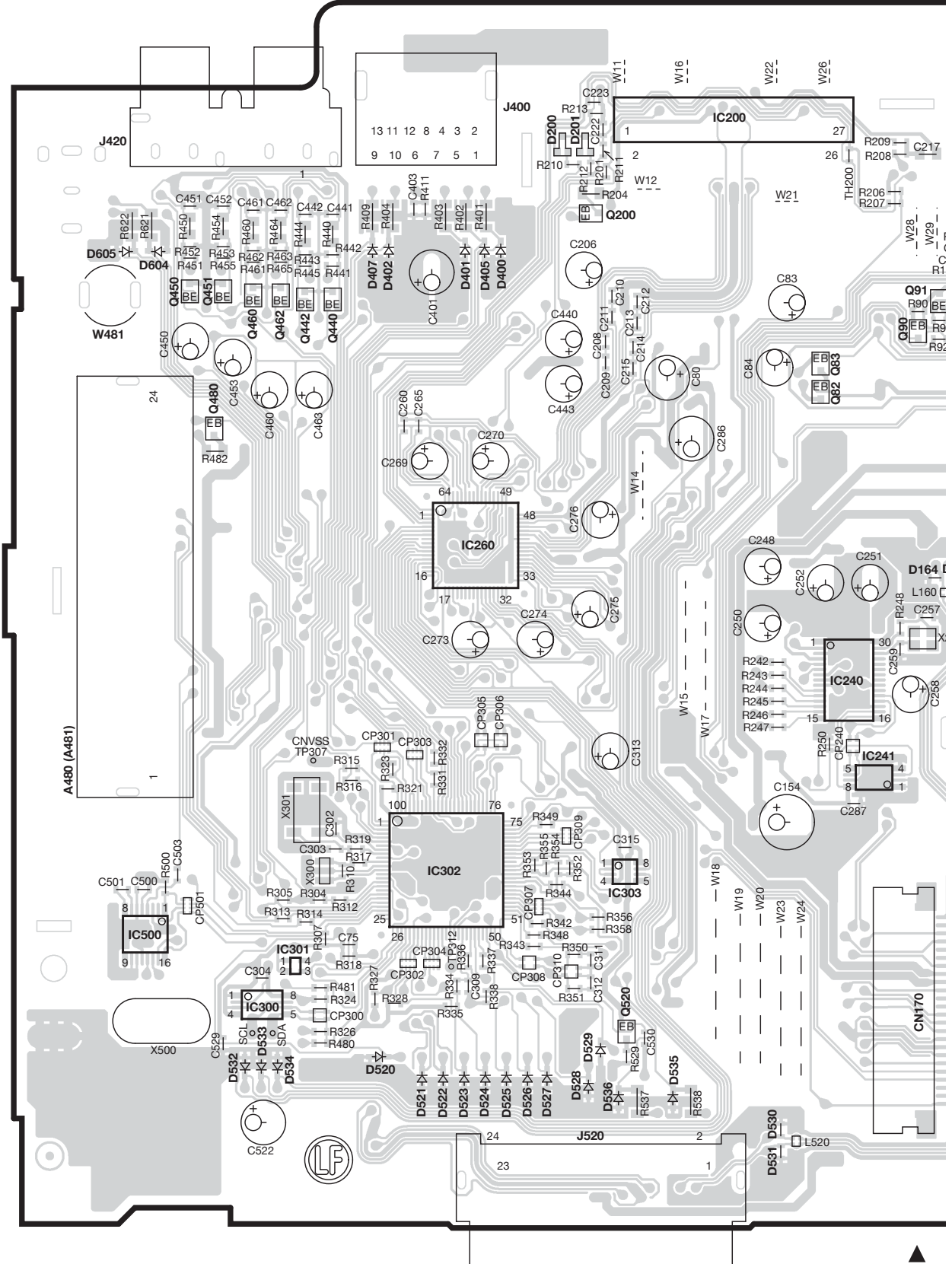

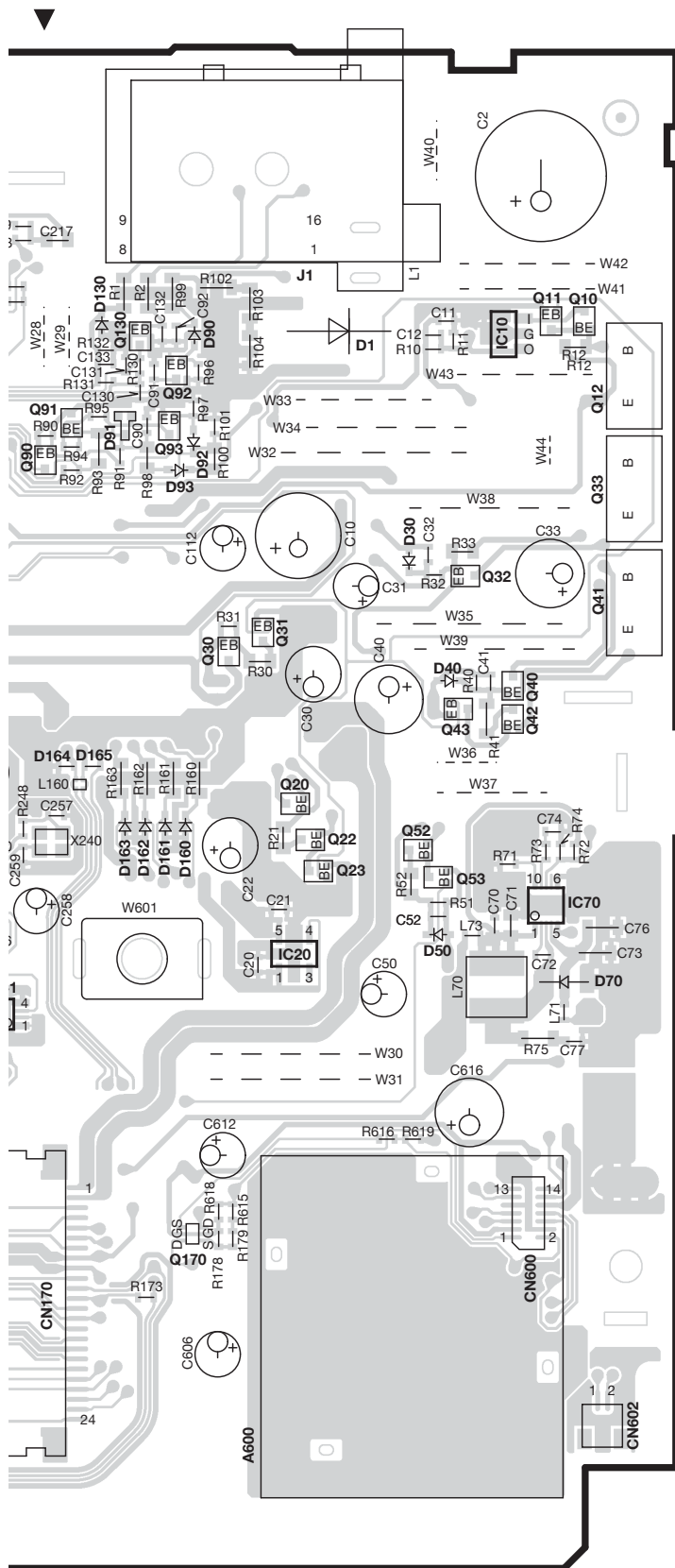

## X34-629x-xx

Ref. No.	Address
IC10	2L
IC70	4M
IC200	2J
IC240	4J
IC241	5J
IC260	4H
IC301	6H
IC302	5H
IC303	5I
IC500	5G
Q10	2M
Q11	2L
Q12	3M
Q20	4L
Q22	4L
Q23	4L
Q30	4K
Q31	3K
Q32	3L
Q33	3M
Q40	4L
Q41	3M
Q42	4L
Q43	4L
Q52	4L
Q53	4L
Q90	3J
Q92	3K
Q93	3K
Q130	2K
Q170	6K
Q440	3H
Q442	3H
Q450	3G
Q451	3G
Q460	3G
Q462	3H
Q480	3G
Q520	6I

Refer to the schematic diagram for the values of resistors and capacitors.

# PC BOARD (FOIL SIDE VIEW)

ELECTRIC UNIT X34-629x-xx (J76-0567-02)

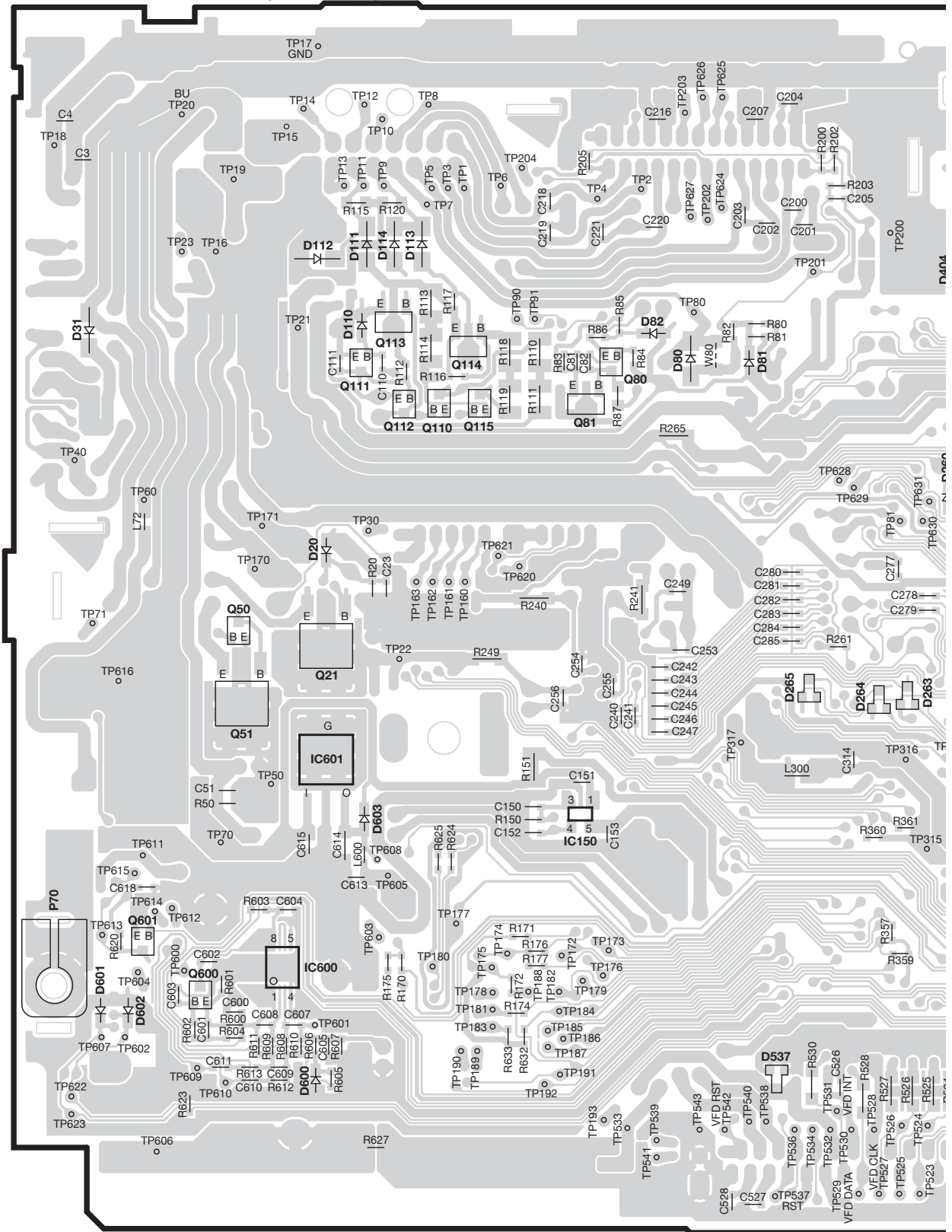

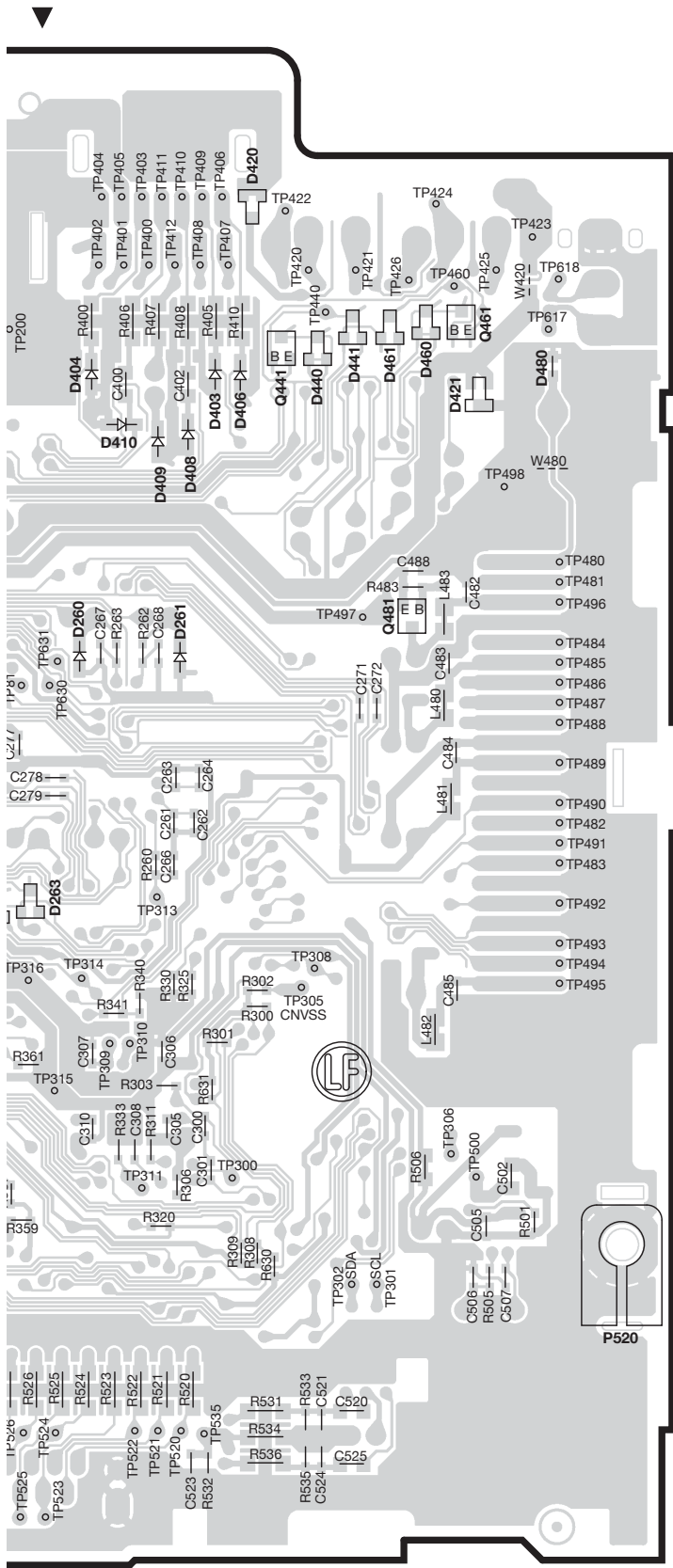

**X34-629x-xx**

Ref. No.	Address
IC150	5S
IC600	6R
IC601	5R
Q21	4R
Q50	4Q
Q51	5Q
Q110	3R
Q111	3R
Q112	3R
Q113	3R
Q114	3R
Q115	3R
Q441	3U
Q461	2V
Q481	3V
Q601	5Q

Refer to the schematic diagram for the values of resistors and capacitors.

KDC-BT6544U/BT6544UY  
/BT7043U/BT742U

# PC BOARD (COMPONENT SIDE VIEW)

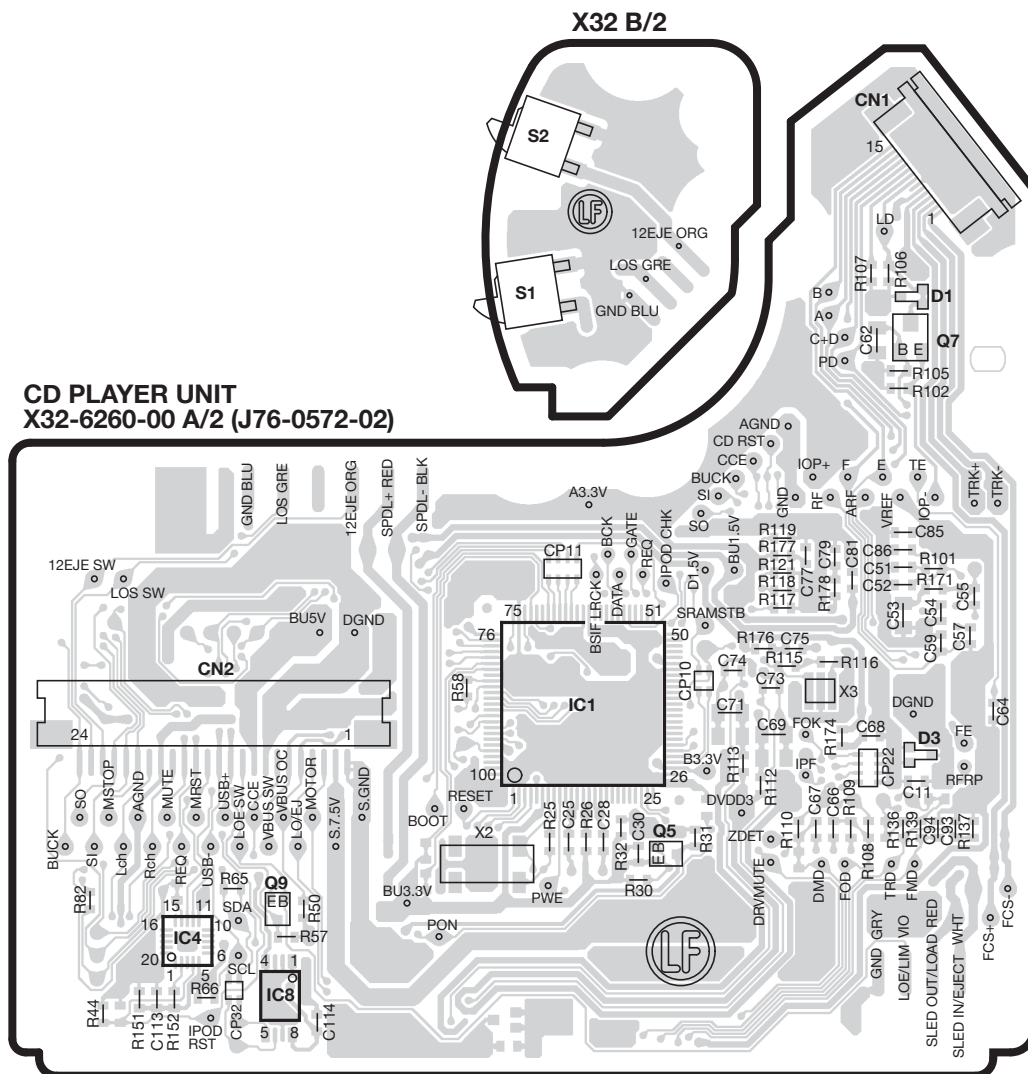

**CD PLAYER UNIT**  
**X32-6260-00 A/2 (J76-0572-02)**

**X32 B/2**

**X32-6260-00**

Ref. No.	Address
IC1	4AB
IC4	4AA
IC8	5AA
Q5	4AC
Q7	2AD
Q9	4AA

Refer to the schematic diagram for the values of resistors and capacitors.

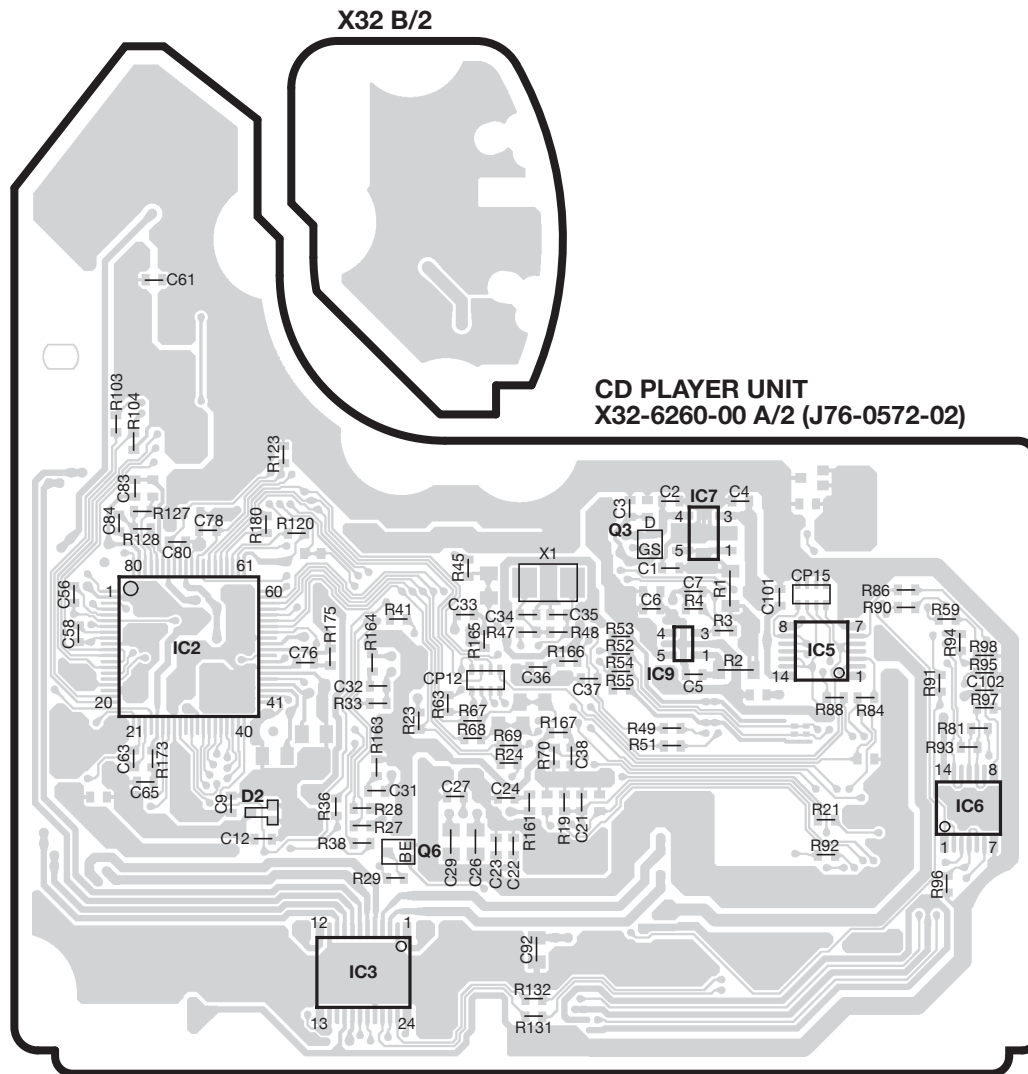

## PC BOARD (FOIL SIDE VIEW)

**X32-6260-00**

Ref. No.	Address
IC2	3AF
IC3	4AF
IC5	3AH
IC6	4AH
IC7	3AG
IC9	3AG
Q3	3AG
Q6	4AF

Refer to the schematic diagram for the values of resistors and capacitors.

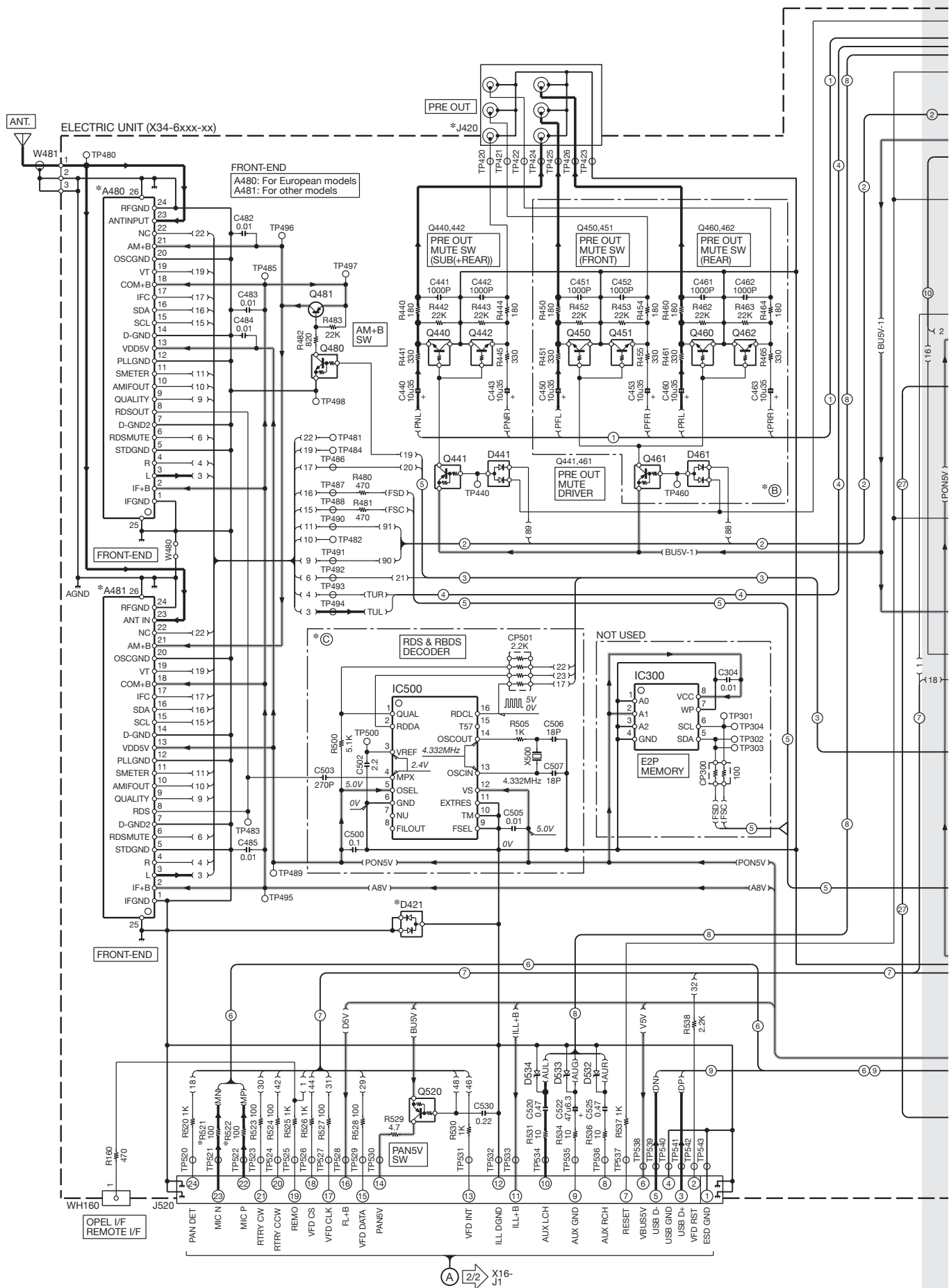



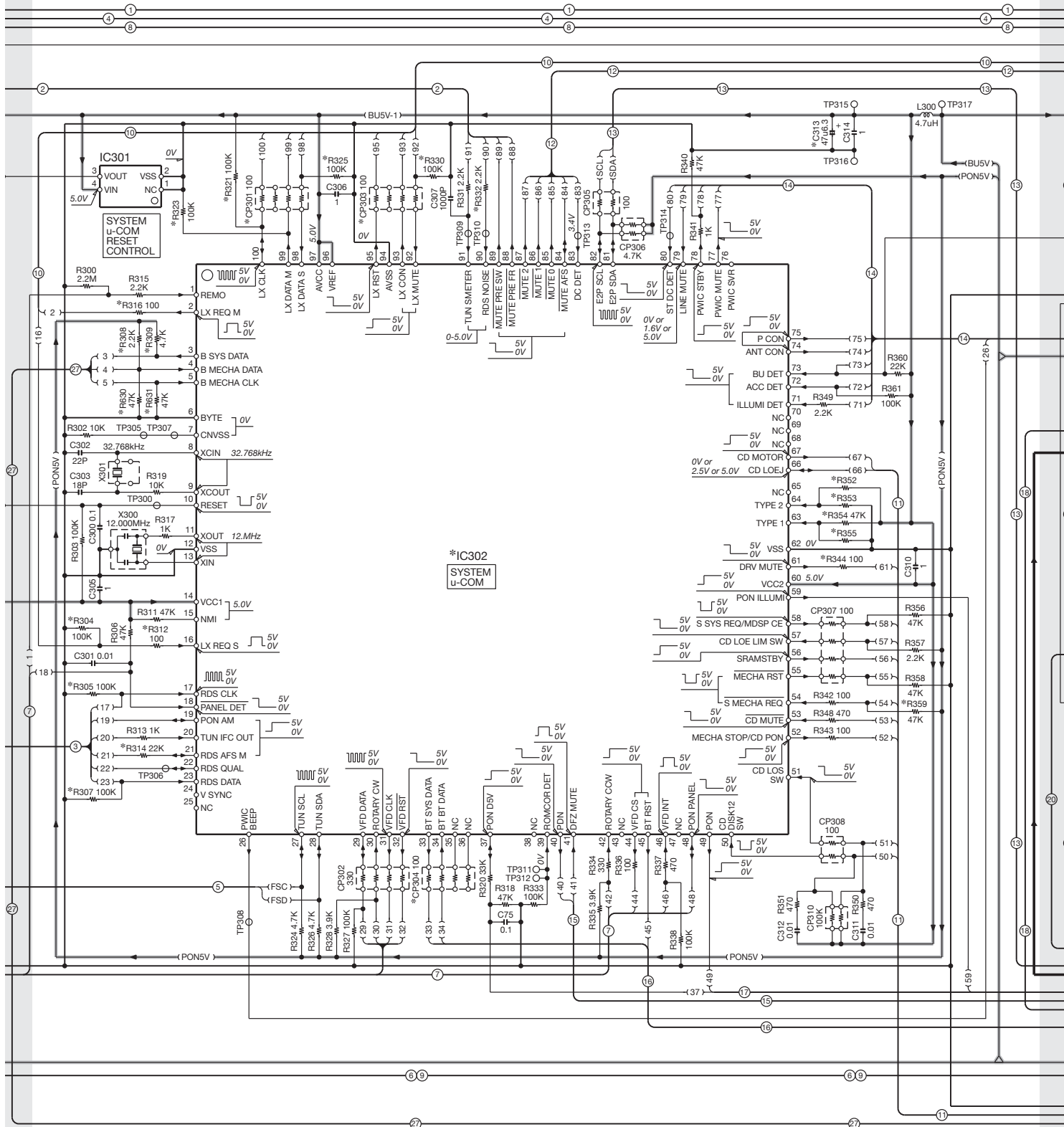

KDC-BT6544U/BT6544UY  
/BT7043U/BT742U

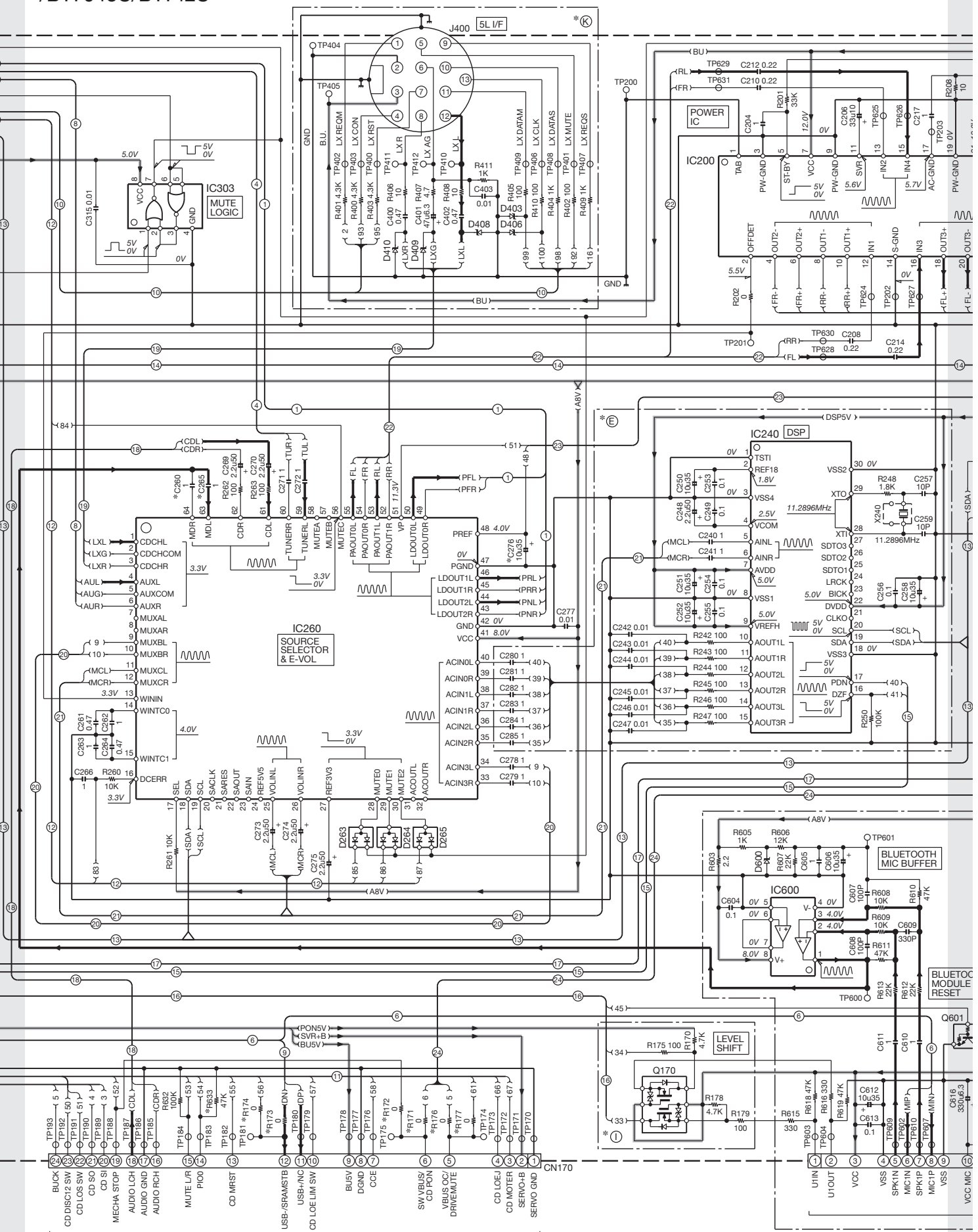

to CD PLAYER UNIT (X32-6260-00) CN2

# KDC-BT6544U/BT6544UY /BT7043U/BT742U

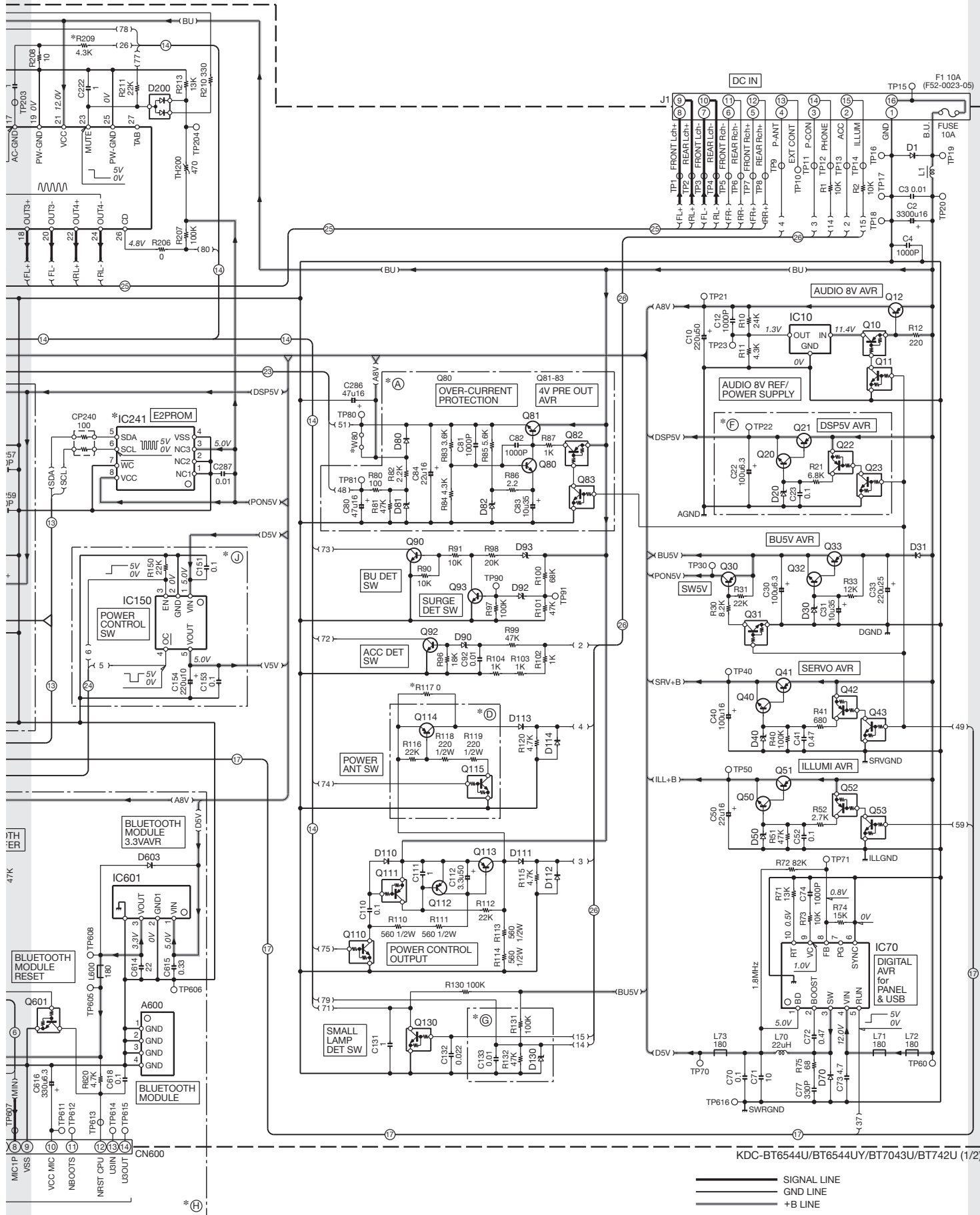

KDC-BT6544U/BT6544UY/BT7043U/BT742U (1/2)

——— SIGNAL LINE  
 - - - GND LINE  
 ———+ +B LINE

KDC-BT6544U/BT6544UY  
/BT7043U/BT742U

IC10 : M5237ML-CF0J  
IC70 : LT3685EMSE  
IC150 : BD6538G  
IC200 : E-TDA7851A  
IC240 : AK7600VF  
IC241 : \*  
IC260 : E-TDA7415CB  
IC300 : XC6120N362N1  
IC302 : \*  
IC303 : 74HC2G02DP  
IC500 : E-TDA7478AD  
IC600 : NJM4565V-ZB  
IC601 : SI-3033KMS

Q10,22,42,52,82,441,461  
: KRA303-P  
Q11,23,31,43,53,83,480,601  
: KRC403-P  
Q12,33,41 : 2SB1565  
Q20,32,40,50,80,90,92,93  
: 2SC4081  
Q21,51 : 2SB1184(Q,R)  
Q30,112 : 2SA1576A  
Q81 : 2SC5053  
Q110,115 : KRC407-P  
Q111 : KRA302-P  
Q113,114 : 2SB1188(Q,R)  
Q130 : KRC404-P  
Q170 : UM6K1N  
Q440,442,450,451,460,462  
: KRC410-P  
Q481 : 2SA1577  
Q520 : KRA307-P

D1 : S2V60-5009F46  
D20,30,81,82

D31 : UDZW5.6(B)  
D40 : D1FJ4  
D40 : UDZW8.2(B)  
D50 : UDZW12(B)  
D70 : CMS14  
D80,111-114

D90,403,406,600  
: D1F60-5063  
D92,93,408-410,532-534  
: UDZW6.2(B)  
D110,603 : UDZW8.8(B)  
D130 : UDZW4.7(B)  
D200,263-265,441,461  
: DAP202U  
D421 : DA204U

MODEL NAME	DESTI-NATION	UNIT No.	(A)	(B)	(C)	(D)	(E)	(F)	(G)	(H)	(I)	(J)	(K)	(L)	(M)	(N)	(O)	(P)	(Q)	(R)	(S)	(T)	(U)	(V)	(W)	(X)	(Y)
IK50	J	X34-6300-01	—	—	—	—	—	—	—	—	—	—	—	—	—	—	—	—	—	—	—	—	—	—	—	—	
KDC-MP442U	K	X34-6300-11	—	—	—	—	—	—	—	—	—	—	—	—	—	—	—	—	—	—	—	—	—	—	—	—	
KDC-K483	K	X34-6300-10	—	—	—	—	—	—	—	—	—	—	—	—	—	—	—	—	—	—	—	—	—	—	—	—	
KDC-MP603U	M	X34-6300-21	—	—	—	—	—	—	—	—	—	—	—	—	—	—	—	—	—	—	—	—	—	—	—	—	
KDC-BT6544U	E1	X34-6302-71	—	—	—	—	—	—	—	—	—	—	—	—	—	—	—	—	—	—	—	—	—	—	—	—	
KDC-BT7043U	E1	X34-6302-72	—	—	—	—	—	—	—	—	—	—	—	—	—	—	—	—	—	—	—	—	—	—	—	—	
KDC-BT6544UY	E2	X34-6292-72	—	—	—	—	—	—	—	—	—	—	—	—	—	—	—	—	—	—	—	—	—	—	—	—	
KDC-BT0044	E3	X34-6292-73	—	—	—	—	—	—	—	—	—	—	—	—	—	—	—	—	—	—	—	—	—	—	—	—	
KDC-BT0144Y	E4	X34-6292-74	—	—	—	—	—	—	—	—	—	—	—	—	—	—	—	—	—	—	—	—	—	—	—	—	
KDC-BT0144Y	R	X34-6553-20	—	—	—	—	—	—	—	—	—	—	—	—	—	—	—	—	—	—	—	—	—	—	—	—	
CKDCMP721U	R	X34-6553-20	—	—	—	—	—	—	—	—	—	—	—	—	—	—	—	—	—	—	—	—	—	—	—	—	

2SB1565

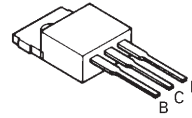

DTC114YUA  
2SA1576A  
2SC4617



2SB1188

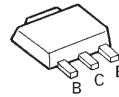

2SB1184

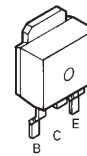

2SC4081

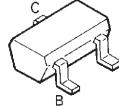

DAP202U  
DA204U



M5237ML-CF0J

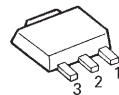

**CAUTION :** For continued safety, replace safety critical components only with manufacturer's recommended parts (refer to parts list).

⚠ Indicates safety critical components. To reduce the risk of electric shock, leakage-current or resistance measurements shall be carried out (exposed parts are acceptably insulated from the supply circuit) before the appliance is returned to the customer.

- DC voltages are as measured with a high impedance voltmeter. Values may vary slightly due to variations between individual instruments or/and units.

# KDC-BT6544U/BT6544UY /BT7043U/BT742U

## SWITCH UNIT (X16-6xxx-xx)

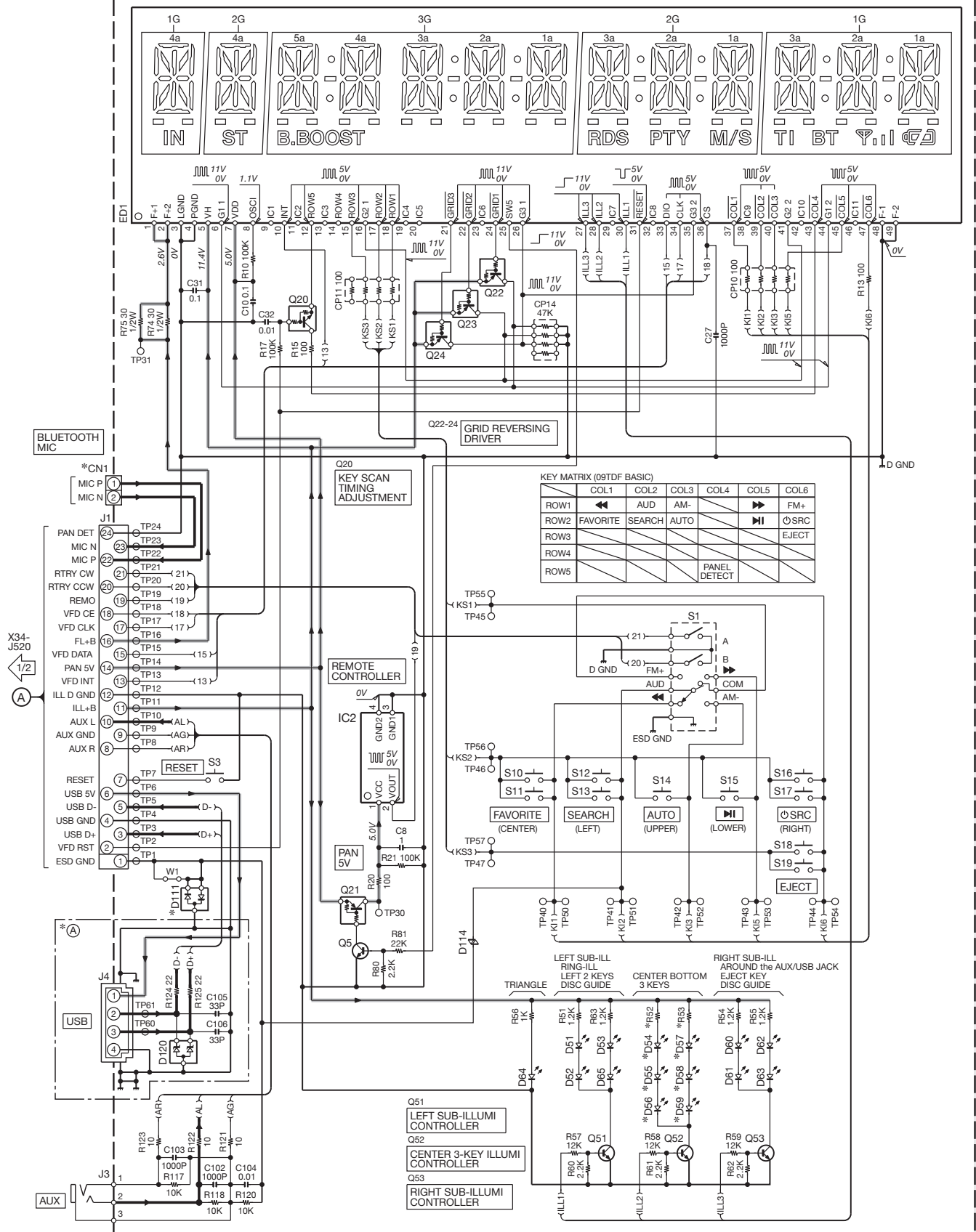

KDC-BT6544U/BT6544UY  
/BT7043U/BT742U

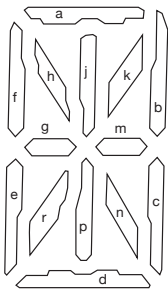
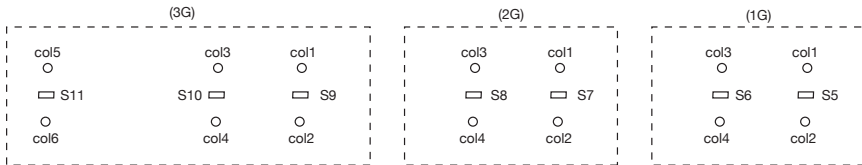
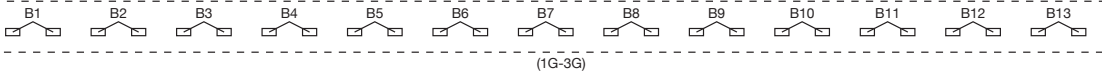

(1G-3G)

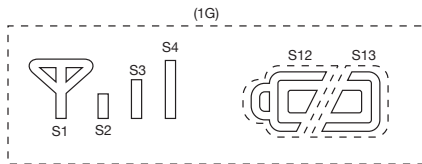

(1G)

	1G	2G	3G
P1	3a	3a	3a
P2	2a	2a	2a
P3	1a	1a	1a
P4	3h	3h	3h
P5	2h	2h	2h
P6	1h	1h	1h
P7	3j	3j	3j
P8	2j	2j	2j
P9	1j	1j	1j
P10	3k	3k	3k
P11	2k	2k	2k
P12	1k	1k	1k
P13	col3	col3	col3
P14	col1	col1	col1
P15	3b	3b	3b
P16	2b	2b	2b
P17	1b	1b	1b
P18	3f	3f	3f
P19	2f	2f	2f
P20	1f	1f	1f
P21	3m	3m	3m
P22	2m	2m	2m
P23	1m	1m	1m
P24	S6	S8	S10
P25	S5	S7	S9
P26	3g	3g	3g
P27	2g	2g	2g
P28	1g	1g	1g
P29	3c	3c	3c
P30	2c	2c	2c
P31	1c	1c	1c
P32	3e	3e	3e
P33	2e	2e	2e
P34	1e	1e	1e
P35	3r	3r	3r
P36	2r	2r	2r
P37	1r	1r	1r
P38	col4	col4	col4
P39	col2	col2	col2
P40	3p	3p	3p
P41	2p	2p	2p
P42	1p	1p	1p
P43	3n	3n	3n
P44	2n	2n	2n
P45	1n	1n	1n
P46	3d	3d	3d
P47	2d	2d	2d
P48	1d	1d	1d
P49	B13	B10	B7
P50	B12	B9	B6
P51	B11	B8	B5
P52	B1	B2	B4
P53	S12	M/S	B3
P54	S13	PTY B.BOOST	
P55	S1	RDS	col5,6
P56	S2	ST	S11
P57	S3	—	4d
P58	S4	—	5d
P59	BT	—	4n
P60	TI	—	5n
P61	IN	—	4p
P62	4d	4d	5p
P63	4n	4n	4r
P64	4p	4p	5r
P65	4r	4r	4e
P66	4e	4e	5e
P67	4c	4c	4c
P68	—	—	5c
P69	4g	4g	4g
P70	—	—	5g
P71	4m	4m	4m
P72	—	—	5m
P73	4f	4f	4f
P74	—	—	5f
P75	4b	4b	4b
P76	—	—	5b
P77	4k	4k	4k
P78	—	—	5k
P79	4j	4j	4j
P80	—	—	5j
P81	4h	4h	4h
P82	—	—	5h
P83	4a	4a	4a
P84	—	—	5a

**CAUTION :** For continued safety, replace safety critical components only with manufacturer's recommended parts (refer to parts list).  
 △ Indicates safety critical components. To reduce the risk of electric shock, leakage-current or resistance measurements shall be carried out (exposed parts are acceptably insulated from the supply circuit) before the appliance is returned to the customer.

- DC voltages are as measured with a high impedance voltmeter. Values may vary slightly due to variations between individual instruments or/and units.

- IC2 : PIC95603      SIGNAL LINE  
                          GND LINE  
 Q5,51-53        +B LINE  
                          : 2SC4617  
 Q20 : KRC404E-P  
 Q21 : KRA302E-P  
 Q22-24: KRA305-P  
  
 D51-53,60-63,65  
                          : B30-3210-05  
 D54-59 : \*  
 D64 : B30-1779-05  
 D111 : DA204U  
 D114 : AVRL1613R3FTA  
 D120 : STZ6.8N

SWITCH UNIT (X16-6xxx-xx)

CATEGORY	MODEL NAME	DESTI-NATION	UNIT No.	Ⓐ	CN1	D111	D54-59	R52, 53
09 USB BASIC	I-K60	J	X16-6500-10	YES	—	—	B30-3210-05	470
	KDC-MP442U	K1						
	KDC-X493	K						
	KDC-MP6043U	M1						
	KDC-W5544U	E1						
	KDC-W5644UY	E2						
09 USB BASIC with Bluetooth	KDC-BT742U	K	X16-6500-21	YES	YES	YES	B30-3210-05	470
	KDC-BT7043U	M1						
	KDC-BT6544U	E1						
09 BASIC with Bluetooth	KDC-BT6544UY	E2	X16-6502-71	—	YES	—	B30-1779-05	560
	KDC-BT6044	E3						
VISTEON	KDC-BT6144Y	E4	X16-6733-20	YES	—	—	B30-3210-05	470
	CKDCMP721U	R						



# KDC-BT6544U/BT6544UY /BT7043U/BT742U

## CD PLAYER UNIT (X32-6260-00) (A/2)

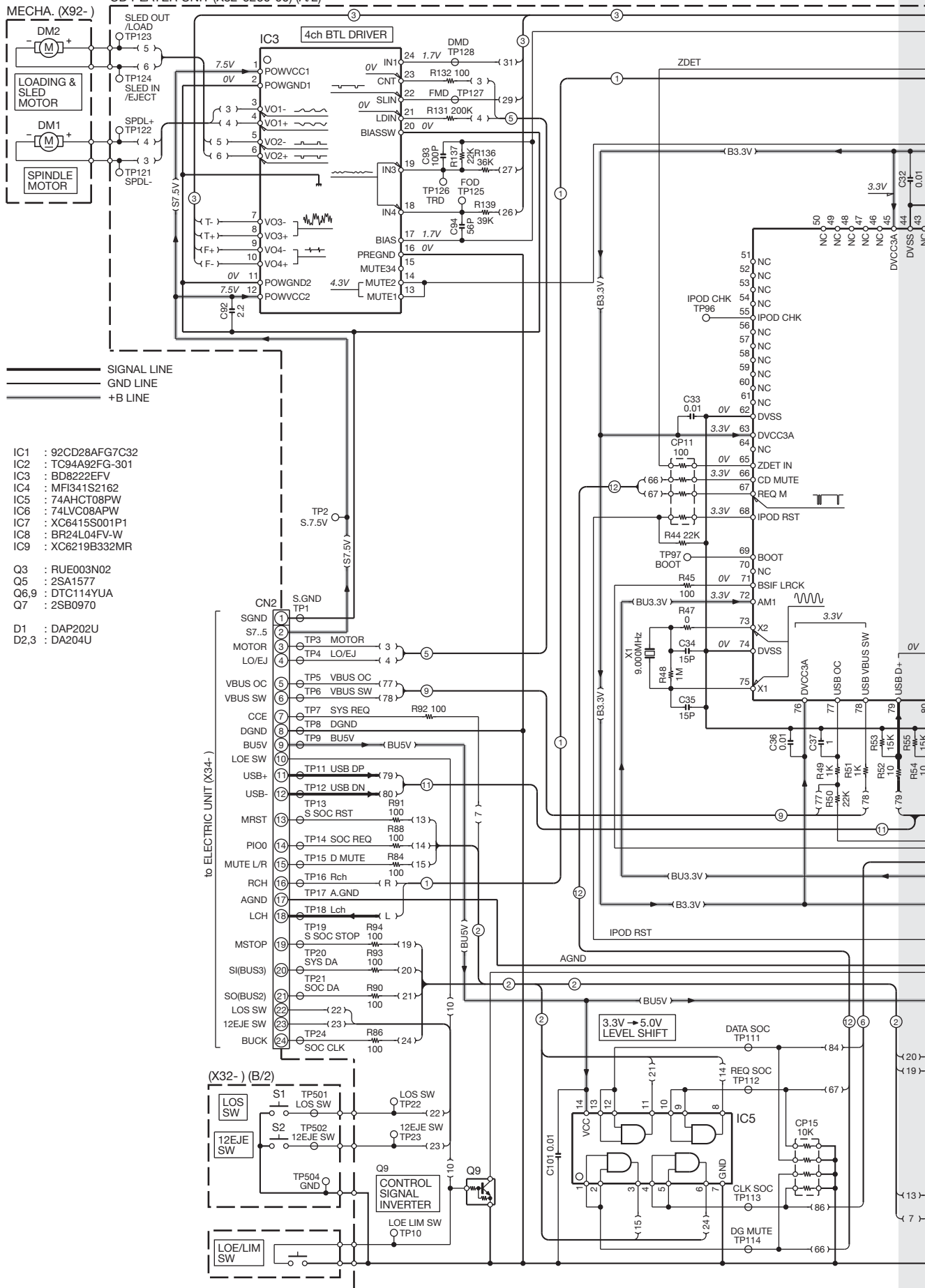

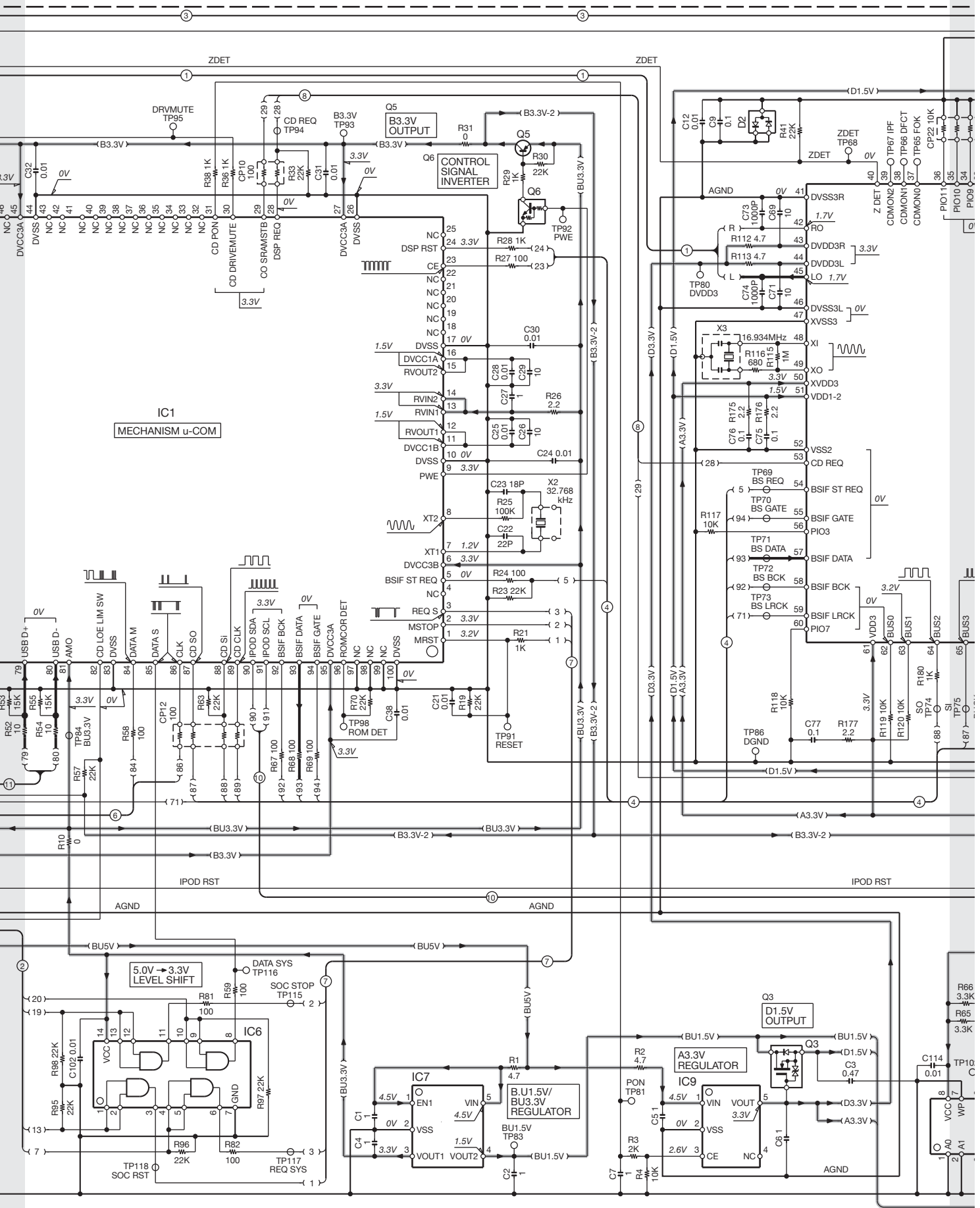



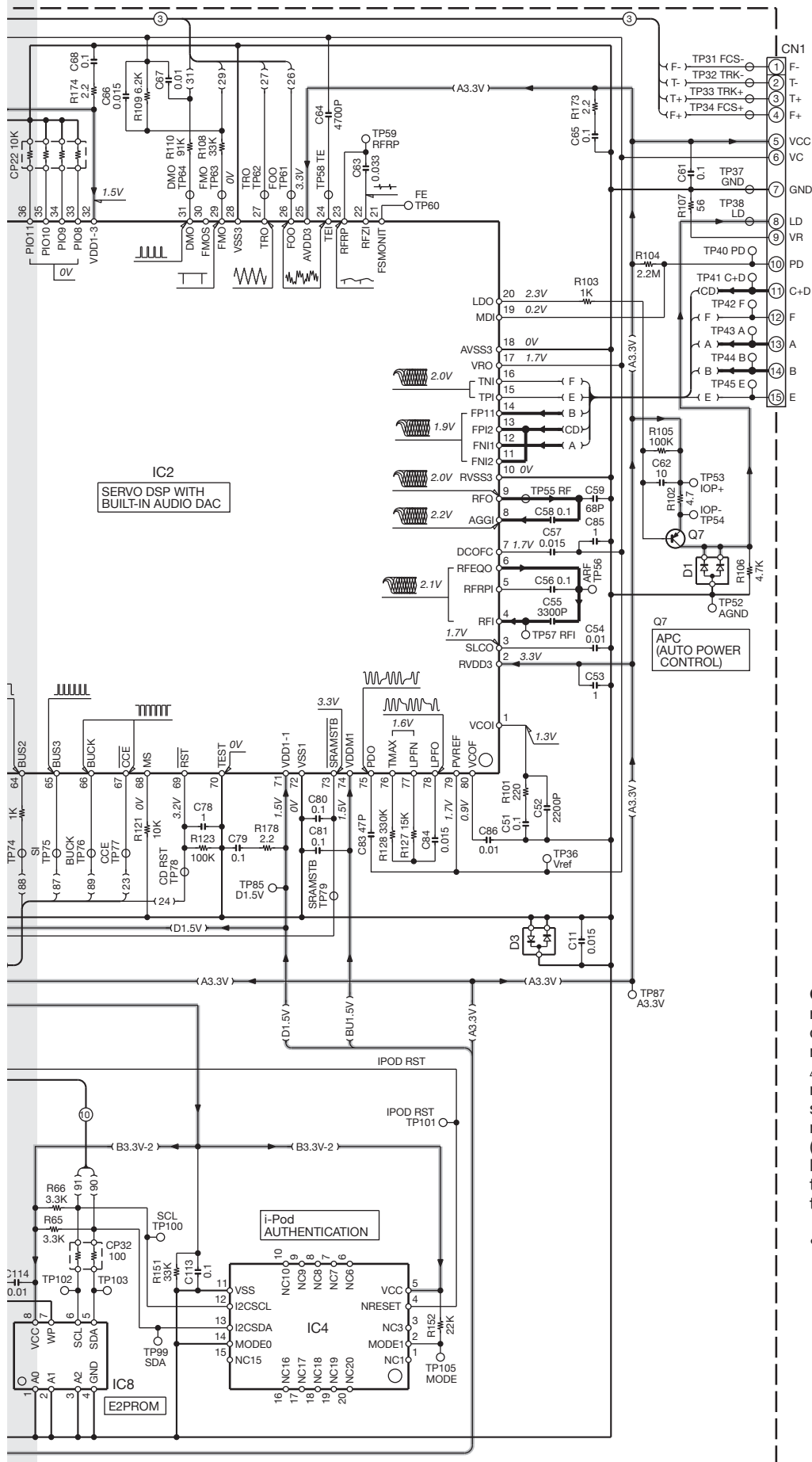

**CAUTION :** For continued safety, replace safety critical components only with manufacturer's recommended parts (refer to parts list).  
 ⚠ Indicates safety critical components. To reduce the risk of electric shock, leakage-current or resistance measurements shall be carried out (exposed parts are acceptably insulated from the supply circuit) before the appliance is returned to the customer.

- DC voltages are as measured with a high impedance voltmeter. Values may vary slightly due to variations between individual instruments or/and units.

# EXPLODED VIEW (CD MECHANISM)

- A : N09-6108-15
- B : N09-6426-15+
- C : N09-6735-05
- D : N09-6737-15
- E : N09-6738-15
- F : N19-2335-14
- G : N35-2003-48
- H : N39-1720-48

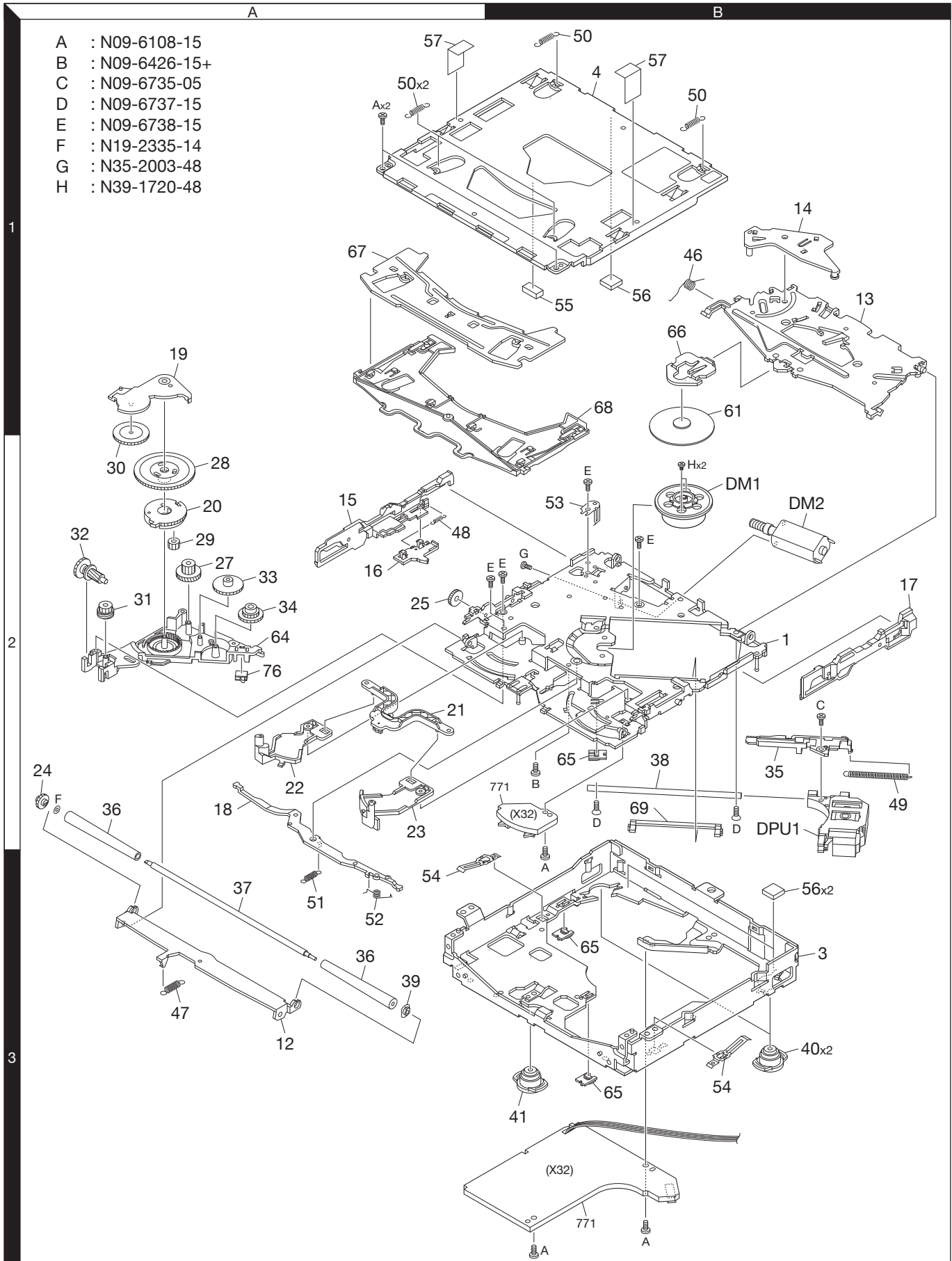

Parts with the exploded numbers larger than 700 are not supplied.

# EXPLODED VIEW (UNIT)

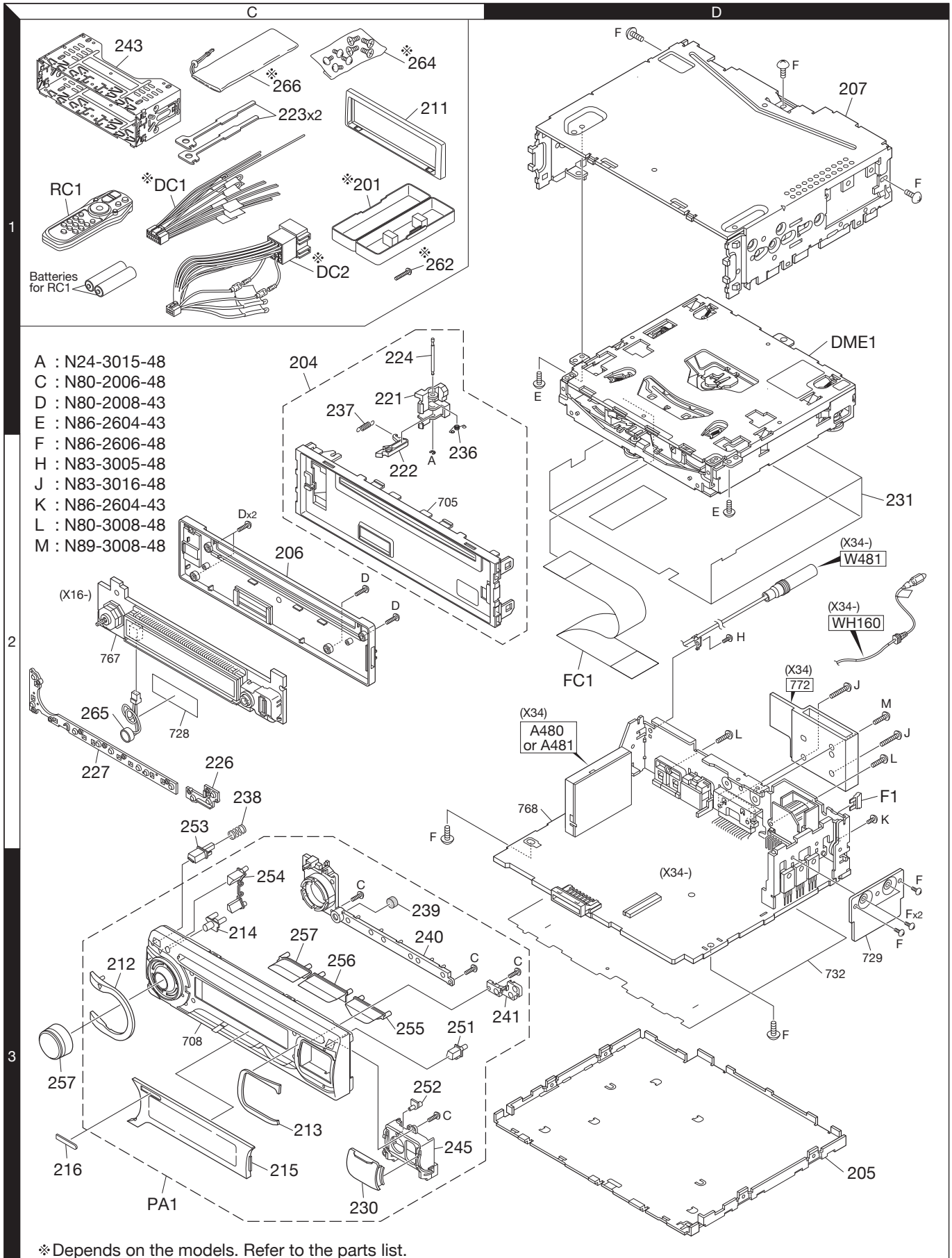

# PARTS LIST

\* New parts

Parts without **Parts No.** are not supplied.

Les articles non mentionnés dans le **Parts No.** ne sont pas fournis.

Teile ohne **Parts No.** werden nicht geliefert.

Ref. No.	A d	N e w	Parts No.	Description	Desti- nation
<b>KDC-BT6544U/BT6544UY/BT7043U/BT742U</b>					
201	1C		A02-2755-23	PLASTIC CABINET ASSY	M1
204	1C	*	A22-3204-03	SUB PANEL ASSY	
205	3D	*	A40-1362-02	BOTTOM PLATE	
206	2C	*	A46-1885-01	REAR COVER	
207	1D	*	A52-1109-01	TOP COVER	
PA1	3C	*	A64-4735-02	PANEL ASSY	K
PA1	3C	*	A64-4736-02	PANEL ASSY	E1E2
PA1	3C	*	A64-4738-02	PANEL ASSY	M1
RC1	1C		A70-2085-15	REMOTE CONTROLLER ASSY (RC-547)	
-		*	B64-4314-00	INST. MANUAL (ENG.FRE.SPA.)	K
-		*	B64-4316-00	INST. MANUAL (ENG.T-CHI.ARA.)	M1
-		*	B64-4317-00	INST. MANUAL (ENGLISH)	E1E2
-		*	B64-4318-00	INST. MANUAL (FRE.GER.DUT.)	E1
-		*	B64-4319-00	INST. MANUAL (ITA.SPA.POR.)	E1
-		*	B64-4320-00	INST. MANUAL (RUSSIAN)	E2
211	1C	*	B07-3244-01	ESCUTCHEON (ACCESSORY)	K
211	1C	*	B07-3245-01	ESCUTCHEON (ACCESSORY)	E1E2M1
212	3C	*	B07-3279-03	ESCUTCHEON (L)	M1
212	3C	*	B07-3280-03	ESCUTCHEON (L)	E1E2
212	3C	*	B07-3312-03	ESCUTCHEON (L)	K
213	3C	*	B07-3289-03	ESCUTCHEON (R)	E1E2M1
213	3C	*	B07-3291-03	ESCUTCHEON (R)	K
214	3C	*	B10-5205-04	FRONT GLASS (REMOTE)	
215	3C	*	B10-5215-01	FRONT GLASS (PANEL)	K
215	3C	*	B10-5216-01	FRONT GLASS (PANEL)	E1E2
215	3C	*	B10-5217-01	FRONT GLASS (PANEL)	M1
216	3C	*	B43-1545-04	BADGE	
221	1C		D10-4446-03	LEVER	
222	2C		D10-4447-03	LEVER	
223	1C		D10-7049-04	LEVER (ACCESSORY)	
224	1C		D21-2329-04	SHAFT	
226	2C	*	E29-2132-03	CONDUCTIVE RUBBER (R)	
227	2C	*	E29-2133-02	CONDUCTIVE RUBBER (L)	
△ DC1	1C		E30-6428-05	DC CORD	KM1
△ DC2	1C		E30-6671-05	DC CORD	E1E2
FC1	2D	*	E39-1055-05	FLAT CABLE	
230	3C	*	F07-2205-02	COVER	
231	2D		F11-1870-13	SHIELDING COVER	
△ F1	2D		F52-0023-05	FUSE (MINI BLADE TYPE) (10A)	
236	2C		G01-2987-04	TORSION COIL SPRING	
237	1C		G01-4662-04	EXTENSION SPRING	
238	2C		G01-3244-04	COMPRESSION SPRING (REL)	
239	3C	*	G11-3778-04	CUSHION (MIC)	
-		*	H54-4530-03	ITEM CARTON CASE	K
-		*	H54-4531-03	ITEM CARTON CASE	E1
-		*	H54-4532-03	ITEM CARTON CASE	E2
-		*	H54-4533-03	ITEM CARTON CASE	M1
240	3C	*	J19-7234-02	HOLDER (L)	
241	3D	*	J19-7235-03	HOLDER (R)	
243	1C		J22-0789-03	MOUNTING HARDWARE ASSY	
245	3C	*	J90-1175-02	GUIDE	

Ref. No.	A d	N e w	Parts No.	Description	Desti- nation
251	3C	*	K24-4976-04	PUSH KNOB (EJECT)	
252	3C	*	K24-4977-04	PUSH KNOB (RESET)	
253	2C	*	K24-4982-04	PUSH KNOB (RELEASE)	
254	3C	*	K25-1944-03	PUSH KNOB (PLAY)	
255	3C	*	K24-4978-03	PUSH KNOB (SRC)	
256	3C	*	K24-4979-03	PUSH KNOB (FAVORITE)	
257	3C	*	K24-4980-03	PUSH KNOB (SEARCH)	
257	3C	*	K28-0353-04	KNOB ASSY (VOL)	
262	1C		N84-4016-48	PAN HEAD TAPTITE SCREW	KM1
264	1C		N99-1757-15	SCREW SET	KM1
A	2C		N24-3015-48	E TYPE RETAINING RING	
C	3C		N80-2006-48	PAN HEAD TAPTITE SCREW	
D	2C		N80-2008-43	PAN HEAD TAPTITE SCREW	
E	1D		N86-2604-43	BINDING HEAD TAPTITE SCREW	
F	1D		N86-2606-48	BINDING HEAD TAPTITE SCREW	
265	2C	*	T91-1006-05	MICROPHONE ASSY	
266	1C		W01-1710-05	CARRYING CASE	KE1E2
DME1	1D	*	X92-6360-00	MECHANISM ASSY (DXM-9B30W)	
<b>SWITCH UNIT (X16-6500-21)</b>					
D51 -63		*	B30-3210-05	LED (1608,BLUE)	
D64			B30-1779-05	LED (1608,SR)	
D65		*	B30-3210-05	LED (1608,BLUE)	
C8			CK73GB1A105K	CHIP C 1.0UF	K
C10			CK73GB1C104K	CHIP C 0.10UF	K
C27			CK73GB1H102K	CHIP C 1000PF	K
C31			CK73GB1C104K	CHIP C 0.10UF	K
C32			CK73GB1H103K	CHIP C 0.010UF	K
C102,103			CK73GB1H102K	CHIP C 1000PF	K
C104			CK73GB1H103K	CHIP C 0.010UF	K
C105,106			CC73GCH1H330J	CHIP C 33PF	J
CN1			E41-1486-05	PIN ASSY	
J1			E59-0855-05	RECTANGULAR PLUG	
J3			E11-0654-05	3.5D PHONE JACK	
J4			E58-1109-05	RECTANGULAR RECEPTACLE	
CP10,11			RK74HB1J101J	CHIP-COM 100	J 1/16W
CP14			RK74HB1J473J	CHIP-COM 47K	J 1/16W
R10			RK73GB2A104J	CHIP R 100K	J 1/10W
R13			RK73GB2A101J	CHIP R 100	J 1/10W
R15			RK73GB2A101J	CHIP R 100	J 1/10W
R17			RK73GB2A104J	CHIP R 100K	J 1/10W
R20			RK73GB2A101J	CHIP R 100	J 1/10W
R21			RK73GB2A104J	CHIP R 100K	J 1/10W
R51			RK73FB2B122J	CHIP R 1.2K	J 1/8W
R52 ,53			RK73FB2B471J	CHIP R 470	J 1/8W
R54 ,55			RK73FB2B122J	CHIP R 1.2K	J 1/8W
R56			RK73EB2E102J	CHIP R 1.0K	J 1/4W
R57 -59			RK73GB2A123J	CHIP R 12K	J 1/10W
R60 -62			RK73GB2A222J	CHIP R 2.2K	J 1/10W
R63			RK73FB2B122J	CHIP R 1.2K	J 1/8W
R74 ,75			RK73PB2H300J	CHIP R 30	J 1/2W
R80			RK73GB2A222J	CHIP R 2.2K	J 1/10W

K : KDC-BT742U M1 : KDC-BT7043U  
E1 : KDC-BT6544U E2 : KDC-BT6544UY

△ Indicates safety critical components.

# PARTS LIST

## SWITCH UNIT (X16-6500-21)

Ref. No.	Add	New	Parts No.	Description	Destination
R81			RK73GB2A223J	CHIP R 22K J 1/10W	
R117,118			RK73GB2A103J	CHIP R 10K J 1/10W	
R120			RK73GB2A103J	CHIP R 10K J 1/10W	
R121-123			RK73FB2B100J	CHIP R 10 J 1/8W	
R124,125			RK73GB2A220J	CHIP R 22 J 1/10W	
W1			R92-2053-05	CHIP R 0 OHM J 1/8W	
S1			S70-0951-05	TACT SWITCH	
D111			DA204U	DIODE	
D114			AVRL1613R3FTA	VARISTOR	
D120			STZ6.8N	ZENER DIODE	
ED1		*	3-BT-263INK	FLUORESCENT INDICATOR TUBE	
IC2			PIC95603	ANALOGUE IC	
Q5			2SC4617	TRANSISTOR	
Q20			KRC404E-P	DIGITAL TRANSISTOR	
Q21			KRA302E-P	DIGITAL TRANSISTOR	
Q22 -24			KRA305-P	DIGITAL TRANSISTOR	
Q51 -53			2SC4617	TRANSISTOR	
<b>CD PLAYER UNIT (X32-6260-00) IN CD MECHA</b>					
C1 ,2			CK73GB1A105K	CHIP C 1.0UF K	
C3			CK73GB1A474K	CHIP C 0.47UF K	
C4 -7			CK73GB1A105K	CHIP C 1.0UF K	
C9			CK73GB1C104K	CHIP C 0.10UF K	
C11			CK73GB1H153K	CHIP C 0.015UF K	
C12			CK73GB1H103K	CHIP C 0.010UF K	
C21			CK73GB1H103K	CHIP C 0.010UF K	
C22			CC73GCH1H220J	CHIP C 22PF J	
C23			CC73GCH1H180J	CHIP C 18PF J	
C24 ,25			CK73GB1H103K	CHIP C 0.010UF K	
C26			CK73FB0J106K	CHIP C 10UF K	
C27			CK73GB1A105K	CHIP C 1.0UF K	
C28			CK73GB1H103K	CHIP C 0.010UF K	
C29			CK73FB0J106K	CHIP C 10UF K	
C30 -33			CK73GB1H103K	CHIP C 0.010UF K	
C34 ,35			CC73GCH1H150J	CHIP C 15PF J	
C36			CK73GB1H103K	CHIP C 0.010UF K	
C37			CK73GB1A105K	CHIP C 1.0UF K	
C38			CK73GB1H103K	CHIP C 0.010UF K	
C51			CK73GB1C104K	CHIP C 0.10UF K	
C52			CK73GB1H222K	CHIP C 2200PF K	
C53			CK73FB1C105K	CHIP C 1.0UF K	
C54			CK73GB1H103K	CHIP C 0.010UF K	
C55			CK73GB1H332K	CHIP C 3300PF K	
C56			CK73GB1C104K	CHIP C 0.10UF K	
C57			CK73GB1H153K	CHIP C 0.015UF K	
C58			CK73GB1C104K	CHIP C 0.10UF K	
C59			CC73GCH1H680J	CHIP C 68PF J	
C61			CK73GB1C104K	CHIP C 0.10UF K	
C62			CK73FB0J106K	CHIP C 10UF K	
C63			CK73GB1H333K	CHIP C 0.033UF K	
C64			CK73GB1H472K	CHIP C 4700PF K	
C65			CK73GB1C104K	CHIP C 0.10UF K	
C66			CK73GB1H153K	CHIP C 0.015UF K	
C67			CK73GB1H103K	CHIP C 0.010UF K	

Ref. No.	Add	New	Parts No.	Description	Destination
C68			CK73GB1C104K	CHIP C 0.10UF K	
C69			CK73FB0J106K	CHIP C 10UF K	
C71			CK73FB0J106K	CHIP C 10UF K	
C73 ,74			CK73GB1H102K	CHIP C 1000PF K	
C75 -77			CK73GB1C104K	CHIP C 0.10UF K	
C78			CK73GB1A105K	CHIP C 1.0UF K	
C79 -81			CK73GB1C104K	CHIP C 0.10UF K	
C83			CC73GCH1H470J	CHIP C 47PF J	
C84			CK73GB1H153K	CHIP C 0.015UF K	
C85			CK73GB1A105K	CHIP C 1.0UF K	
C86			CK73GB1H103K	CHIP C 0.010UF K	
C92			CK73FB1A225K	CHIP C 2.2UF K	
C93			CC73GCH1H101J	CHIP C 100PF J	
C94			CC73GCH1H560J	CHIP C 56PF J	
C101,102			CK73GB1H103K	CHIP C 0.010UF K	
C113			CK73GB1C104K	CHIP C 0.10UF K	
C114			CK73GB1H103K	CHIP C 0.010UF K	
CN1			E41-2954-05	FLAT CABLE CONNECTOR	
CN2			E41-2083-15	FLAT CABLE CONNECTOR	
X1			L77-2964-05	CRYSTAL RESONATOR (9.00MHZ)	
X2			L77-2921-15	CRYSTAL RESONATOR (32.768KHZ)	
X3			L78-1221-05	RESONATOR (16.93MHZ)	
CP10			RK74GA1J101J	CHIP-COM 100 J 1/16W	
CP11,12			RK74GB1J101J	CHIP-COM 100 J 1/16W	
CP15			RK74GB1J103J	CHIP-COM 10K J 1/16W	
CP22			RK74GB1J103J	CHIP-COM 10K J 1/16W	
CP32			RK74GA1J101J	CHIP-COM 100 J 1/16W	
R1 ,2			RK73EB2E4R7J	CHIP R 4.7 J 1/4W	
R3			RK73GB2A202J	CHIP R 2.0K J 1/10W	
R4			RK73GB2A103J	CHIP R 10K J 1/10W	
R10			RK73GB2A000J	CHIP R 0.0 J 1/10W	
R19			RK73GB2A223J	CHIP R 22K J 1/10W	
R21			RK73GB2A102J	CHIP R 1.0K J 1/10W	
R23			RK73GB2A223J	CHIP R 22K J 1/10W	
R24			RK73GB2A101J	CHIP R 100 J 1/10W	
R25			RK73GB2A104J	CHIP R 100K J 1/10W	
R26			RK73GB2A2R2J	CHIP R 2.2 J 1/10W	
R27			RK73GB2A101J	CHIP R 100 J 1/10W	
R28 ,29			RK73GB2A102J	CHIP R 1.0K J 1/10W	
R30			RK73GB2A223J	CHIP R 22K J 1/10W	
R31			RK73GB2A000J	CHIP R 0.0 J 1/10W	
R33			RK73GB2A223J	CHIP R 22K J 1/10W	
R36			RK73GB2A102J	CHIP R 1.0K J 1/10W	
R38			RK73GB2A102J	CHIP R 1.0K J 1/10W	
R41			RK73GB2A223J	CHIP R 22K J 1/10W	
R44			RK73GB2A223J	CHIP R 22K J 1/10W	
R45			RK73GB2A101J	CHIP R 100 J 1/10W	
R47			RK73GB2A000J	CHIP R 0.0 J 1/10W	
R48			RK73GB2A105J	CHIP R 1.0M J 1/10W	
R49			RK73GB2A102J	CHIP R 1.0K J 1/10W	
R50			RK73GB2A223J	CHIP R 22K J 1/10W	
R51			RK73GB2A102J	CHIP R 1.0K J 1/10W	
R52			RK73GB2A100J	CHIP R 10 J 1/10W	

K : KDC-BT742U M1 : KDC-BT7043U  
E1 : KDC-BT6544U E2 : KDC-BT6544UY

△ Indicates safety critical components.



# PARTS LIST

## CD PLAYER UNIT (X32-6260-00) IN CD MECHA

Ref. No.	Add	New	Parts No.	Description	Destination
R53			RK73GB2A153J	CHIP R 15K J 1/10W	
R54			RK73GB2A100J	CHIP R 10 J 1/10W	
R55			RK73GB2A153J	CHIP R 15K J 1/10W	
R57			RK73GB2A223J	CHIP R 22K J 1/10W	
R58 ,59			RK73GB2A101J	CHIP R 100 J 1/10W	
R63			RK73GB2A223J	CHIP R 22K J 1/10W	
R65 ,66			RK73GB2A332J	CHIP R 3.3K J 1/10W	
R67 -69			RK73GB2A101J	CHIP R 100 J 1/10W	
R70			RK73GB2A223J	CHIP R 22K J 1/10W	
R81 ,82			RK73GB2A101J	CHIP R 100 J 1/10W	
R84			RK73GB2A101J	CHIP R 100 J 1/10W	
R86			RK73GB2A101J	CHIP R 100 J 1/10W	
R88			RK73GB2A101J	CHIP R 100 J 1/10W	
R90 -94			RK73GB2A101J	CHIP R 100 J 1/10W	
R95 -98			RK73GB2A223J	CHIP R 22K J 1/10W	
R101			RK73GB2A221J	CHIP R 220 J 1/10W	
R102			RK73GB2A4R7J	CHIP R 4.7 J 1/10W	
R103			RK73GB2A102J	CHIP R 1.0K J 1/10W	
R104			RK73GB2A225J	CHIP R 2.2M J 1/10W	
R105			RK73GB2A104J	CHIP R 100K J 1/10W	
R106			RK73GB2A472J	CHIP R 4.7K J 1/10W	
R107			RK73GB2A560J	CHIP R 56 J 1/10W	
R108			RK73GB2A333J	CHIP R 33K J 1/10W	
R109			RK73GB2A622J	CHIP R 6.2K J 1/10W	
R110			RK73GB2A913J	CHIP R 91K J 1/10W	
R112,113			RK73GB2A4R7J	CHIP R 4.7 J 1/10W	
R115			RK73GB2A105J	CHIP R 1.0M J 1/10W	
R116			RK73GB2A681J	CHIP R 680 J 1/10W	
R117-121			RK73GB2A103J	CHIP R 10K J 1/10W	
R123			RK73GB2A104J	CHIP R 100K J 1/10W	
R127			RK73GB2A153J	CHIP R 15K J 1/10W	
R128			RK73GB2A334J	CHIP R 330K J 1/10W	
R131			RK73GB2A204J	CHIP R 200K J 1/10W	
R132			RK73GB2A101J	CHIP R 100 J 1/10W	
R136			RK73GB2A363J	CHIP R 36K J 1/10W	
R137			RK73GB2A223J	CHIP R 22K J 1/10W	
R139			RK73GB2A393J	CHIP R 39K J 1/10W	
R151			RK73GB2A333J	CHIP R 33K J 1/10W	
R152			RK73GB2A223J	CHIP R 22K J 1/10W	
R173-178			RK73GB2A2R2J	CHIP R 2.2 J 1/10W	
R180			RK73GB2A102J	CHIP R 1.0K J 1/10W	
S1 ,2			S68-0924-05	PUSH SWITCH	
D1			DAP202U	DIODE	
D2 ,3			DA204U	DIODE	
IC1		*	92CD28AFG7C32	MICROCONTROLLER IC	
IC2			TC94A92FG-301	MOS-IC	
IC3			BD8222EFV	ANALOGUE IC	
IC4			MF1341S2162	MICROPROCESSOR IC	
IC5			74AHCT08PW	MOS-IC	
IC6			74LVC08APW	MOS-IC	
IC7			XC6415S001P1	MOS-IC	
IC8			BR24L04FV-W	ROM IC	
IC9			XC6219B332MR	ANALOGUE IC	

Ref. No.	Add	New	Parts No.	Description	Destination
Q3			RUE003N02	FET	
Q5			2SA1577	TRANSISTOR	
Q6			DTC114YUA	DIGITAL TRANSISTOR	
Q7			2SB0970	TRANSISTOR	
Q9			DTC114YUA	DIGITAL TRANSISTOR	
<b>ELECTRIC UNIT (X34-629x-xx)</b>					
C2			CD04AZ1C332M2	ELECTRO 3300UF 16WV	
C3			CK73GB1H103K	CHIP C 0.010UF K	
C4			CK73GB1H102K	CHIP C 1000PF K	
C10			CD04AT1A221M	ELECTRO 220UF 10WV	
C12			CK73GB1H102K	CHIP C 1000PF K	
C22			CD04AS0J101M	ELECTRO 100UF 6.3WV	KE1E2
C23			CK73GB1C104K	CHIP C 0.10UF K	KE1E2
C30			CD04AS0J101M	ELECTRO 100UF 6.3WV	
C31			CD04AS1V100M	ELECTRO 10UF 35WV	
C33			C90-6851-05	ELECTRO 220UF 25WV	
C40			CD04AS1C101M	ELECTRO 100UF 16WV	
C41			CK73GB1A474K	CHIP C 0.47UF K	
C50			CD04AS1C220M	ELECTRO 22UF 16WV	
C52			CK73GB1C104K	CHIP C 0.10UF K	
C70			CK73GB1C104K	CHIP C 0.10UF K	
C71			CK73FB0J106K	CHIP C 10UF K	
C72			CK73GB1A474K	CHIP C 0.47UF K	
C73		*	CK73EB1H475K	CHIP C 4.7UF K	
C74			CK73GB1H102K	CHIP C 1000PF K	
C75			CK73GB1C104K	CHIP C 0.10UF K	
C77			CC73GCH1H331J	CHIP C 330PF J	
C92			CK73GB1H103K	CHIP C 0.010UF K	
C110			CK73GB1H104K	CHIP C 0.10UF K	
C111			CK73GB1A105K	CHIP C 1.0UF K	
C112			CD04AS1H3R3M	ELECTRO 3.3UF 50WV	
C131			CK73GB1A105K	CHIP C 1.0UF K	
C132			CK73GB1H223K	CHIP C 0.022UF K	
C133			CK73GB1H103K	CHIP C 0.010UF K	
C151			CK73GB1C104K	CHIP C 0.10UF K	
C153			CK73GB1C104K	CHIP C 0.10UF K	
C154			CD04BK1A221M	ELECTRO 220UF 10WV	
C204			CK73GB1A105K	CHIP C 1.0UF K	
C206			CD04AS1A330M	ELECTRO 33UF 10WV	
C208			CK73GB1A224K	CHIP C 0.22UF K	
C210			CK73GB1A224K	CHIP C 0.22UF K	
C212			CK73GB1A224K	CHIP C 0.22UF K	
C214			CK73GB1A224K	CHIP C 0.22UF K	
C217			CK73FB1C105K	CHIP C 1.0UF K	
C222			CK73GB1A105K	CHIP C 1.0UF K	
C240,241			CK73GB1A105K	CHIP C 1.0UF K	KE1E2
C242-247			CK73GB1H103K	CHIP C 0.010UF K	KE1E2
C248			CD04AS1H2R2M	ELECTRO 2.2UF 50WV	KE1E2
C249			CK73GB1C104K	CHIP C 0.10UF K	KE1E2
C250-252			CD04AS1V100M	ELECTRO 10UF 35WV	KE1E2
C253-256			CK73GB1C104K	CHIP C 0.10UF K	KE1E2
C257			CC73GCH1H100D	CHIP C 10PF D	KE1E2
C258			CD04AS1V100M	ELECTRO 10UF 35WV	KE1E2
C259			CC73GCH1H100D	CHIP C 10PF D	KE1E2
C260			CK73GB1A105K	CHIP C 1.0UF K	

# PARTS LIST

## ELECTRIC UNIT (X34-629x-xx)

Ref. No.	Add	New	Parts No.	Description	Destination	Ref. No.	Add	New	Parts No.	Description	Destination
C261			CK73GB1A474K	CHIP C 0.47UF K		C615			CK73FB1H334K	CHIP C 0.33UF K	
C262,263			CK73GB1A105K	CHIP C 1.0UF K		C616			CD04BK0J331M	ELECTRO 330UF 6.3WV	
C264			CK73GB1A474K	CHIP C 0.47UF K		C618			CK73GB1C104K	CHIP C 0.10UF K	
C265,266			CK73GB1A105K	CHIP C 1.0UF K		CN170			E41-2352-05	FLAT CABLE CONNECTOR	
C269,270			CD04AS1H2R2M	ELECTRO 2.2UF 50WV		CN600			E41-3043-05	PIN ASSY	
C271,272			CK73GB1A105K	CHIP C 1.0UF K		J1			E58-0991-05	RECTANGULAR RECEPTACLE	
C273-275			CD04AS1H2R2M	ELECTRO 2.2UF 50WV		J400			E56-0855-05	CYLINDRICAL RECEPTACLE	
C276			CD04AS1V100M	ELECTRO 10UF 35WV		J420			E63-0960-05	PIN JACK (3-PRE)	
C277			CK73GB1H103K	CHIP C 0.010UF K		J520			E58-1095-05	RECTANGULAR RECEPTACLE	
C278-285			CK73GB1A105K	CHIP C 1.0UF K	KE1E2	W481	2D		E30-6438-05	CORD WITH PLUG (ANT)	
C278,279			CK73GB1A105K	CHIP C 1.0UF K	M1	WH160	2D	*	E30-6870-05	WIRING HARNESS (REMOTE)	
C286			CD04AS1C470M	ELECTRO 47UF 16WV		L1			L33-2365-05	CHOKE COIL ASSY	
C287			CK73GB1H103K	CHIP C 0.010UF K		L70			L33-2462-05	SMALL FIXED INDUCTOR	
C300			CK73GB1C104K	CHIP C 0.10UF K		L71 -73		*	L92-0662-05	CHIP FERRITE	
C301			CK73GB1H103K	CHIP C 0.010UF K		L300			L41-4795-33	SMALL FIXED INDUCTOR (4.7UH)	
C302			CC73GCH1H220J	CHIP C 22PF J		L600			L92-0373-05	CHIP FERRITE	
C303			CC73GCH1H180J	CHIP C 18PF J		X240			L77-3810-05	CRYSTAL RESONATOR (11.2896MHZ)	KE1E2
C305,306			CK73GB0J105K	CHIP C 1.0UF K		X300			L78-0872-05	RESONATOR (12MHZ)	
C307			CK73GB1H102K	CHIP C 1000PF K		X301			L77-2921-15	CRYSTAL RESONATOR (32.768KHZ)	
C310			CK73GB0J105K	CHIP C 1.0UF K		X500			L77-2002-05	CRYSTAL RESONATOR E1E2	
C311,312			CK73GB1H103K	CHIP C 0.010UF K		H	2D		N83-3005-48	PAN HEAD TAPTITE SCREW	
C314			CK73GB1A105K	CHIP C 1.0UF K		J	2D		N83-3016-48	PAN HEAD TAPTITE SCREW	
C315			CK73GB1H103K	CHIP C 0.010UF K		K	2D		N86-2604-43	BINDING HEAD TAPTITE SCREW	
C400			CK73FB1E474K	CHIP C 0.47UF K		L	2D		N80-3008-48	PAN HEAD TAPTITE SCREW	
C401			CD04AT0J470M	ELECTRO 47UF 6.3WV		M	2D		N89-3008-48	BINDING HEAD TAPTITE SCREW	
C402			CK73FB1E474K	CHIP C 0.47UF K		CP240			RK74GA1J101J	CHIP-COM 100 J 1/16W	
C403			CK73GB1H103K	CHIP C 0.010UF K		CP301			RK74HB1J101J	CHIP-COM 100 J 1/16W	
C440			CD04AS1V100M	ELECTRO 10UF 35WV		CP302			RK74HB1J331J	CHIP-COM 330 J 1/16W	
C441,442			CK73GB1H102K	CHIP C 1000PF K		CP303,304			RK74HB1J101J	CHIP-COM 100 J 1/16W	
C443			CD04AS1V100M	ELECTRO 10UF 35WV		CP305			RK74GA1J101J	CHIP-COM 100 J 1/16W	
C450			CD04AS1V100M	ELECTRO 10UF 35WV		CP306			RK74GA1J472J	CHIP-COM 4.7K J 1/16W	
C451,452			CK73GB1H102K	CHIP C 1000PF K		CP307			RK74HB1J101J	CHIP-COM 100 J 1/16W	
C453			CD04AS1V100M	ELECTRO 10UF 35WV		CP308			RK74GA1J101J	CHIP-COM 100 J 1/16W	
C460			CD04AS1V100M	ELECTRO 10UF 35WV		CP310			RK74GA1J104J	CHIP-COM 100K J 1/16W	
C461,462			CK73GB1H102K	CHIP C 1000PF K		CP501			RK74HB1J222J	CHIP-COM 2.2K J 1/16W	E1E2
C463			CD04AS1V100M	ELECTRO 10UF 35WV		R1 ,2			RK73EB2E103J	CHIP R 10K J 1/4W	
C482-485			CK73GB1H103K	CHIP C 0.010UF K	E1E2	R10			RK73GH2A243D	CHIP R 24K D 1/10W	
C500			CK73GB1C104K	CHIP C 0.10UF K	E1E2	R11			RK73GH2A432D	CHIP R 4.3K D 1/10W	
C502			CK73FB1A225K	CHIP C 2.2UF K	E1E2	R12			RK73FB2B221J	CHIP R 220 J 1/8W	
C503			CC73GCH1H271J	CHIP C 270PF J	E1E2	R21			RK73FB2B682J	CHIP R 6.8K J 1/8W	KE1E2
C505			CK73GB1H103K	CHIP C 0.010UF K	E1E2	R30			RK73FB2B822J	CHIP R 8.2K J 1/8W	
C506,507			CC73GCH1H180J	CHIP C 18PF J	E1E2	R31			RK73GB2A223J	CHIP R 22K J 1/10W	
C520			CK73FB1E474K	CHIP C 0.47UF K		R33			RK73FB2B123J	CHIP R 12K J 1/8W	
C522			CD04AT0J470M	ELECTRO 47UF 6.3WV		R40			RK73GB2A104J	CHIP R 100K J 1/10W	
C525			CK73FB1E474K	CHIP C 0.47UF K		R41			RK73EB2E681J	CHIP R 680 J 1/4W	
C530			CK73GB1A224K	CHIP C 0.22UF K		R51			RK73GB2A473J	CHIP R 47K J 1/10W	
C604			CK73GB1C104K	CHIP C 0.10UF K		R52			RK73FB2B272J	CHIP R 2.7K J 1/8W	
C605			CK73GB1A105K	CHIP C 1.0UF K		R71			RK73GH2A133D	CHIP R 13K D 1/10W	
C606			CD04AS1V100M	ELECTRO 10UF 35WV		R72			RK73GH2A823D	CHIP R 82K D 1/10W	
C607,608			CC73GCH1H101J	CHIP C 100PF J		R73			RK73GB2A103J	CHIP R 10K J 1/10W	
C609			CC73GCH1H331J	CHIP C 330PF J		R74			RK73GH2A153D	CHIP R 15K D 1/10W	
C610,611			CK73GB1A105K	CHIP C 1.0UF K		R75			RK73EB2E680J	CHIP R 68 J 1/4W	
C612			CD04AS1V100M	ELECTRO 10UF 35WV		R90 ,91			RK73GB2A103J	CHIP R 10K J 1/10W	
C613			CK73GB1C104K	CHIP C 0.10UF K		R96			RK73GB2A183J	CHIP R 18K J 1/10W	
C614			CK73EB0J226K	CHIP C 22UF K							

K : KDC-BT742U M1 : KDC-BT7043U  
E1 : KDC-BT6544U E2 : KDC-BT6544UY

△ Indicates safety critical components.

# PARTS LIST

## ELECTRIC UNIT (X34-629x-xx)

Ref. No.	A d d	N e w	Parts No.	Description	Desti- nation
R97			RK73GB2A104J	CHIP R 100K J 1/10W	
R98			RK73FB2B203J	CHIP R 20K J 1/8W	
R99			RK73EB2E473J	CHIP R 47K J 1/4W	
R100			RK73FB2B683J	CHIP R 68K J 1/8W	
R101			RK73GB2A473J	CHIP R 47K J 1/10W	
R102-104			RK73EB2E102J	CHIP R 1.0K J 1/4W	
R110,111			RK73PB2H561J	CHIP R 560 J 1/2W	
R112			RK73GB2A223J	CHIP R 22K J 1/10W	
R113,114			RK73PB2H561J	CHIP R 560 J 1/2W	
R115			RK73FB2B472J	CHIP R 4.7K J 1/8W	
R116			RK73GB2A223J	CHIP R 22K J 1/10W	KM1
R117			RK73GB2A000J	CHIP R 0.0 J 1/10W	E1E2
R118,119			RK73PB2H221J	CHIP R 220 J 1/2W	KM1
R120			RK73FB2B472J	CHIP R 4.7K J 1/8W	
R130,131			RK73GB2A104J	CHIP R 100K J 1/10W	
R132			RK73GB2A473J	CHIP R 47K J 1/10W	
R150			RK73GB2A223J	CHIP R 22K J 1/10W	
R160			RK73EB2E471J	CHIP R 470 J 1/4W	
R170			RK73GB2A472J	CHIP R 4.7K J 1/10W	
R171			RK73GB2A000J	CHIP R 0.0 J 1/10W	
R173			RK73GB2A000J	CHIP R 0.0 J 1/10W	
R175			RK73GB2A101J	CHIP R 100 J 1/10W	
R176			RK73GB2A000J	CHIP R 0.0 J 1/10W	
R178			RK73GB2A472J	CHIP R 4.7K J 1/10W	
R179			RK73GB2A101J	CHIP R 100 J 1/10W	
R201			RK73GB2A333J	CHIP R 33K J 1/10W	
R202			RK73GB2A000J	CHIP R 0.0 J 1/10W	
R206			RK73GB2A000J	CHIP R 0.0 J 1/10W	
R207			RK73GB2A104J	CHIP R 100K J 1/10W	
R208			RK73GB2A100J	CHIP R 10 J 1/10W	
R209			RK73GB2A432J	CHIP R 4.3K J 1/10W	
R210			RK73GB2A331J	CHIP R 330 J 1/10W	
R211			RK73GB2A223J	CHIP R 22K J 1/10W	
R213			RK73GB2A133J	CHIP R 13K J 1/10W	
R242-247			RK73GB2A101J	CHIP R 100 J 1/10W	KE1E2
R248			RK73GB2A182J	CHIP R 1.8K J 1/10W	KE1E2
R250			RK73GB2A104J	CHIP R 100K J 1/10W	KE1E2
R260,261			RK73GB2A103J	CHIP R 10K J 1/10W	
R262,263			RK73GB2A101J	CHIP R 100 J 1/10W	
R300			RK73GB2A225J	CHIP R 2.2M J 1/10W	
R302			RK73GB2A103J	CHIP R 10K J 1/10W	
R303-305			RK73GB2A104J	CHIP R 100K J 1/10W	E1E2
R303,304			RK73GB2A104J	CHIP R 100K J 1/10W	KM1
R306			RK73GB2A473J	CHIP R 47K J 1/10W	
R307			RK73GB2A104J	CHIP R 100K J 1/10W	E1E2
R311			RK73GB2A473J	CHIP R 47K J 1/10W	
R312			RK73GB2A101J	CHIP R 100 J 1/10W	
R313			RK73GB2A102J	CHIP R 1.0K J 1/10W	
R314			RK73GB2A223J	CHIP R 22K J 1/10W	E1E2
R315			RK73GB2A222J	CHIP R 2.2K J 1/10W	
R316			RK73GB2A101J	CHIP R 100 J 1/10W	
R317			RK73GB2A102J	CHIP R 1.0K J 1/10W	
R318			RK73GB2A473J	CHIP R 47K J 1/10W	
R319			RK73GB2A103J	CHIP R 10K J 1/10W	
R320			RK73GB2A333J	CHIP R 33K J 1/10W	

Ref. No.	A d d	N e w	Parts No.	Description	Desti- nation
R321			RK73GB2A104J	CHIP R 100K J 1/10W	
R323			RK73GB2A104J	CHIP R 100K J 1/10W	
R324			RK73GB2A472J	CHIP R 4.7K J 1/10W	
R325			RK73GB2A104J	CHIP R 100K J 1/10W	
R326			RK73GB2A472J	CHIP R 4.7K J 1/10W	
R327			RK73GB2A104J	CHIP R 100K J 1/10W	
R328			RK73GB2A392J	CHIP R 3.9K J 1/10W	
R330			RK73GB2A104J	CHIP R 100K J 1/10W	
R331			RK73GB2A222J	CHIP R 2.2K J 1/10W	KM1
R331,332			RK73GB2A222J	CHIP R 2.2K J 1/10W	E1E2
R333			RK73GB2A104J	CHIP R 100K J 1/10W	
R334			RK73GB2A331J	CHIP R 330 J 1/10W	
R335			RK73GB2A392J	CHIP R 3.9K J 1/10W	
R336			RK73GB2A101J	CHIP R 100 J 1/10W	
R337			RK73GB2A471J	CHIP R 470 J 1/10W	
R338			RK73GB2A104J	CHIP R 100K J 1/10W	
R340			RK73GB2A473J	CHIP R 47K J 1/10W	
R341			RK73GB2A102J	CHIP R 1.0K J 1/10W	
R342,343			RK73GB2A101J	CHIP R 100 J 1/10W	
R348			RK73GB2A471J	CHIP R 470 J 1/10W	
R349			RK73GB2A222J	CHIP R 2.2K J 1/10W	
R350,351			RK73GB2A471J	CHIP R 470 J 1/10W	
R352			RK73GB2A223J	CHIP R 22K J 1/10W	E2
R352			RK73GB2A473J	CHIP R 47K J 1/10W	M1
R352,353			RK73GB2A473J	CHIP R 47K J 1/10W	E1
R353			RK73GB2A223J	CHIP R 22K J 1/10W	M1
R353			RK73GB2A473J	CHIP R 47K J 1/10W	KE2
R356			RK73GB2A473J	CHIP R 47K J 1/10W	
R357			RK73GB2A222J	CHIP R 2.2K J 1/10W	
R358			RK73GB2A473J	CHIP R 47K J 1/10W	
R360			RK73GB2A223J	CHIP R 22K J 1/10W	
R361			RK73GB2A104J	CHIP R 100K J 1/10W	
R400,401			RK73EB2E432J	CHIP R 4.3K J 1/4W	
R402			RK73EB2E101J	CHIP R 100 J 1/4W	
R403			RK73EB2E432J	CHIP R 4.3K J 1/4W	
R404			RK73EB2E102J	CHIP R 1.0K J 1/4W	
R405			RK73EB2E101J	CHIP R 100 J 1/4W	
R406			RK73EB2E100J	CHIP R 10 J 1/4W	
R407			RK73EB2E4R7J	CHIP R 4.7 J 1/4W	
R408			RK73EB2E100J	CHIP R 10 J 1/4W	
R409			RK73EB2E102J	CHIP R 1.0K J 1/4W	
R410			RK73EB2E101J	CHIP R 100 J 1/4W	
R411			RK73GB2A102J	CHIP R 1.0K J 1/10W	
R440			RK73FB2B181J	CHIP R 180 J 1/8W	
R441			RK73GB2A331J	CHIP R 330 J 1/10W	
R442,443			RK73GB2A223J	CHIP R 22K J 1/10W	
R444			RK73FB2B181J	CHIP R 180 J 1/8W	
R445			RK73GB2A331J	CHIP R 330 J 1/10W	
R450			RK73FB2B181J	CHIP R 180 J 1/8W	
R451			RK73GB2A331J	CHIP R 330 J 1/10W	
R452,453			RK73GB2A223J	CHIP R 22K J 1/10W	
R454			RK73FB2B181J	CHIP R 180 J 1/8W	
R455			RK73GB2A331J	CHIP R 330 J 1/10W	
R460			RK73FB2B181J	CHIP R 180 J 1/8W	
R461			RK73GB2A331J	CHIP R 330 J 1/10W	

K : KDC-BT742U M1 : KDC-BT7043U  
E1 : KDC-BT6544U E2 : KDC-BT6544UY

△Indicates safety critical components.



# PARTS LIST

## ELECTRIC UNIT (X34-629x-xx)

Ref. No.	Add	New	Parts No.	Description	Destination	Ref. No.	Add	New	Parts No.	Description	Destination
R462,463			RK73GB2A223J	CHIP R 22K J 1/10W		D532-534			UDZW6.8(B)	ZENER DIODE	
R464			RK73FB2B181J	CHIP R 180 J 1/8W		D600			UDZW6.2(B)	ZENER DIODE	
R465			RK73GB2A331J	CHIP R 330 J 1/10W		D603			1SS355	DIODE	
R480,481			RK73GB2A471J	CHIP R 470 J 1/10W		IC10			M5237ML-CF0J	ANALOGUE IC	
R482			RK73FB2B821J	CHIP R 820 J 1/8W		IC70	*		LT3685EMSE	ANALOGUE IC	
R483			RK73GB2A223J	CHIP R 22K J 1/10W		IC150			BD6538G	MOS-IC	
R500			RK73GB2A512J	CHIP R 5.1K J 1/10W	E1E2	IC200			E-TDA7851A	ANALOGUE IC	
R505			RK73GB2A102J	CHIP R 1.0K J 1/10W	E1E2	IC240			AK7600VF	MOS-IC	KE1E2
R520			RK73EB2E102J	CHIP R 1.0K J 1/4W		IC241			M24C16-RDW6P	ROM IC	
R521-524			RK73EB2E101J	CHIP R 100 J 1/4W		IC260			E-TDA7415CB	ANALOGUE IC	
R525,526			RK73EB2E102J	CHIP R 1.0K J 1/4W		IC301			XC6120N362N1	MOS-IC	
R527,528			RK73EB2E101J	CHIP R 100 J 1/4W		IC302	*		30626MHPB93GP	MICROCONTROLLER IC	K
R529			RK73GB2A4R7J	CHIP R 4.7 J 1/10W		IC302	*		30626MHPB94GP	MICROCONTROLLER IC	M1
R530			RK73EB2E102J	CHIP R 1.0K J 1/4W		IC302	*		30626MHPB95GP	MICROCONTROLLER IC	E1E2
R531			RK73EB2E100J	CHIP R 10 J 1/4W		IC303			74HC2G02DP	MOS-IC	
R534			RK73EB2E100J	CHIP R 10 J 1/4W		IC500			E-TDA7478AD	ANALOGUE IC	E1E2
R536			RK73EB2E100J	CHIP R 10 J 1/4W		IC600			NJM4565V-ZB	ANALOGUE IC	
R537			RK73EB2E102J	CHIP R 1.0K J 1/4W		IC601			SI-3033KMS	ANALOGUE IC	
R538			RK73EB2E222J	CHIP R 2.2K J 1/4W		Q10			KRA303-P	DIGITAL TRANSISTOR	
R603			RK73GB2A2R2J	CHIP R 2.2 J 1/10W		Q11			KRC403-P	DIGITAL TRANSISTOR	
R605			RK73GB2A102J	CHIP R 1.0K J 1/10W		Q12			2SB1565	TRANSISTOR	
R606			RK73GB2A123J	CHIP R 12K J 1/10W		Q20			2SC4081	TRANSISTOR	KE1E2
R607			RK73GB2A223J	CHIP R 22K J 1/10W		Q21			2SB1184(Q,R)	TRANSISTOR	KE1E2
R608,609			RK73GB2A103J	CHIP R 10K J 1/10W		Q22			KRA303-P	DIGITAL TRANSISTOR	KE1E2
R610,611			RK73GB2A473J	CHIP R 47K J 1/10W		Q23			KRC403-P	DIGITAL TRANSISTOR	KE1E2
R612,613			RK73GB2A223J	CHIP R 22K J 1/10W		Q30			2SA1576A	TRANSISTOR	
R615,616			RK73GB2A331J	CHIP R 330 J 1/10W		Q31			KRC403-P	DIGITAL TRANSISTOR	
R618,619			RK73GB2A473J	CHIP R 47K J 1/10W		Q32			2SC4081	TRANSISTOR	
R620			RK73GB2A472J	CHIP R 4.7K J 1/10W		Q33			2SB1565	TRANSISTOR	
R630,631			RK73GB2A473J	CHIP R 47K J 1/10W		Q40			2SC4081	TRANSISTOR	
R632			RK73GB2A104J	CHIP R 100K J 1/10W		Q41			2SB1565	TRANSISTOR	
R633			RK73GB2A473J	CHIP R 47K J 1/10W		Q42			KRA303-P	DIGITAL TRANSISTOR	
W80			R92-2053-05	CHIP R 0 OHM J 1/8W		Q43			KRC403-P	DIGITAL TRANSISTOR	
W480			R92-2053-05	CHIP R 0 OHM J 1/8W		Q50			2SC4081	TRANSISTOR	
						Q51			2SB1184(Q,R)	TRANSISTOR	
D1			S2V60-5009F46	DIODE		Q52			KRA303-P	DIGITAL TRANSISTOR	
D20	*		UDZW5.6(B)	ZENER DIODE	KE1E2	Q53			KRC403-P	DIGITAL TRANSISTOR	
D30	*		UDZW5.6(B)	ZENER DIODE		Q90			2SC4081	TRANSISTOR	
D31			D1FJ4	DIODE		Q92,93			2SC4081	TRANSISTOR	
D40			UDZW8.2(B)	ZENER DIODE		Q110			KRC407-P	DIGITAL TRANSISTOR	
D50			UDZW12(B)	ZENER DIODE		Q111			KRA302-P	DIGITAL TRANSISTOR	
D70	*		CMS14	DIODE		Q112			2SA1576A	TRANSISTOR	
D90			UDZW6.2(B)	ZENER DIODE		Q113			2SB1188(Q,R)	TRANSISTOR	E1E2
D92,93			UDZW6.8(B)	ZENER DIODE		Q113,114			2SB1188(Q,R)	TRANSISTOR	KM1
D110			1SS355	DIODE		Q115			KRC407-P	DIGITAL TRANSISTOR	KM1
D111-114			D1F60-5063	DIODE		Q130			KRC404-P	DIGITAL TRANSISTOR	
D130	*		UDZW4.7(B)	ZENER DIODE		Q170			UM6K1N	DUAL FET	
D200			DAP202U	DIODE		Q440			KRC410-P	DIGITAL TRANSISTOR	
D263-265			DAP202U	DIODE		Q441			KRA303-P	DIGITAL TRANSISTOR	
D403			UDZW6.2(B)	ZENER DIODE		Q442			KRC410-P	DIGITAL TRANSISTOR	
D406			UDZW6.2(B)	ZENER DIODE		Q450,451			KRC410-P	DIGITAL TRANSISTOR	
D408-410			UDZW6.8(B)	ZENER DIODE		Q460			KRC410-P	DIGITAL TRANSISTOR	
D421			DA204U	DIODE	KE1E2	Q461			KRA303-P	DIGITAL TRANSISTOR	
D441			DAP202U	DIODE		Q462			KRC410-P	DIGITAL TRANSISTOR	
D461			DAP202U	DIODE		Q480			KRC403-P	DIGITAL TRANSISTOR	

K : KDC-BT742U M1 : KDC-BT7043U  
E1 : KDC-BT6544U E2 : KDC-BT6544UY

△ Indicates safety critical components.

# PARTS LIST

## ELECTRIC UNIT (X34-629x-xx)

Ref. No.	A d d	N e w	Parts No.	Description	Desti- nation
Q481 Q520 Q601 TH200			2SA1577 KRA307-P KRC403-P PRF18BE471QS2	TRANSISTOR DIGITAL TRANSISTOR DIGITAL TRANSISTOR POSITIVE RESISTOR	
A600		*	W02-5337-05	ELECTRIC CIRCUIT MODULE	
A480 A481	2D 2D		X86-4032-70 X86-4230-11	FRONT-END UNIT FRONT-END UNIT	E1E2 KM1
<b>MECHANISM ASSY (X92-6360-00) DXM-9B30W</b>					
1	2B		A10-5450-53	CHASSIS ASSY	
3	3B		A10-5452-41	CHASSIS	
4	1B		A10-5453-32	CHASSIS	
12	3A		D10-4993-52	LEVER	
13	1B		D10-4991-22	ARM	
14	1B		D10-4992-13	ARM	
15	2A		D10-4994-02	SLIDER	
16	2A		D10-4995-03	SLIDER	
17	2B		D10-4996-02	SLIDER	
18	2A		D10-4997-03	LEVER	
19	1A		D10-4998-03	ARM	
20	2A		D10-4999-03	ARM	
21	2A		D10-7001-03	ARM	
22	2A		D10-7002-03	ARM	
23	2A		D10-7003-03	ARM	
24	2A		D13-2445-04	GEAR	
25	2A		D13-2446-04	GEAR	
27	2A		D13-2448-04	GEAR	
28	2A		D13-2449-04	GEAR	
29	2A		D13-2450-04	GEAR	
30	2A		D13-2451-04	GEAR	
31	2A		D13-2452-04	GEAR	
32	2A		D13-2453-04	GEAR	
33	2A		D13-2454-04	GEAR	
34	2A		D13-2455-04	GEAR	
35	2B		D13-2456-03	RACK (GEAR)	
36	2A		D14-1028-04	ROLLER	
37	3A		D21-2507-04	SHAFT	
38	2B		D21-2508-04	SHAFT	
39	3A		D23-0963-04	RETAINER	
40	3B		D39-0277-15	DAMPER	
41	3B		D39-0278-15	DAMPER	
46	1B		G01-4682-34	TORSION COIL SPRING	
47	3A		G01-4683-24	EXTENSION SPRING	
48	2A		G01-4684-04	EXTENSION SPRING	
49	2B		G01-4685-04	EXTENSION SPRING	
50	1B		G01-4686-14	EXTENSION SPRING	
51	3A		G01-4688-14	EXTENSION SPRING	
52	3A		G01-4692-24	TORSION COIL SPRING	
53	2B		G02-1587-04	FLAT SPRING	
54	3A		G02-1588-04	FLAT SPRING	
55	1B		G13-1297-04	CUSHION	
56	1B		G13-1299-14	CUSHION	
57	1A		G16-1715-04	SHEET	

Ref. No.	A d d	N e w	Parts No.	Description	Desti- nation
61	1B		J11-0675-03	CLAMPER	
64	2A		J19-7210-21	HOLDER	
65	2B		J19-7225-04	HOLDER	
66	1B		J22-0706-03	MOUNTING HARDWARE	
67	1A		J22-0707-12	MOUNTING HARDWARE	
68	1B	*	J90-1166-11	GUIDE	
69	2B		J90-1168-03	RAIL	
A	1A		N09-6108-15	TAPTITE SCREW (M2X3.5)	
B	2B		N09-6426-15+	MACHINE SCREW	
C	2B		N09-6735-05	TAPTITE SCREW	
D	2B		N09-6737-15	MACHINE SCREW	
E	2B		N09-6738-15	TAPTITE SCREW	
F	2A		N19-2335-14	FLAT WASHER	
G	2B		N35-2003-48	BINDING HEAD MACHINE SCREW	
H	2B		N39-1720-48	PAN HEAD MACHINE SCREW	
76	2A		S68-0921-05	PUSH SWITCH	
DM1	2B		X94-2090-00	SPINDLE MOTOR ASSY	
DM2	2B		X94-2100-00	FEED MOTOR ASSY (LOAD/SLED)	
DPU1	2B	*	X93-2280-00	OPTICAL PICKUP ASSY	

# SPECIFICATIONS

## ■ Models for destination “K”

### FM tuner section

Frequency range (200kHz space).....	87.9MHz~107.9MHz
Usable sensitivity (S/N=30dB).....	9.3dBf (0.8μV/75Ω)
Quieting Sensitivity (S/N=50dB).....	15.2dBf (1.6μV/75Ω)
Frequency response (±3.0dB).....	30Hz~15kHz
Signal to Noise ratio (MONO).....	70dB
Selectivity (±400kHz).....	≥80dB
Stereo separation (1kHz).....	40dB

### AM tuner section

Frequency range (10kHz space).....	530kHz~1700kHz
Usable sensitivity (S/N=20dB).....	28dBμ (25μV)

### Bluetooth section

Version.....	Bluetooth Ver. 2.0 Certified
Frequency range.....	2.402GHz~2.480GHz
Output Power.....	+4dBm (MAX), 0dBm (AVE) Power Class 2
Maximum Communication range.....	Line of sight approx.10m (32.8ft)
Profiles.....	HFP (Hands Free Profile)
.....	HSP (Headset Profile)
.....	SPP (Serial Port Profile)
.....	PBAP (Phonebook Access Profile)
.....	OPP (Object Push Profile)
.....	SYNC (Synchronization Profile)

### CD player section

Laser diode.....	GaAIs
Digital filter (D/A).....	8 Times Over Sampling
D/A Converter.....	24Bit
Spindle speed.....	500~200rpm (CLV)
Wow & Flutter.....	Below Measurable Limit
Frequency response (±1dB).....	20Hz~20kHz
Total harmonic distortion (1kHz).....	0.01%
Signal to Noise ratio (1kHz).....	105dB
Dynamic range.....	93dB
MP3 decode.....	Compliant with MPEG-1/2 Audio Layer-3
WMA decode.....	Compliant with Windows Media Audio

### USB Interface

USB standard.....	USB1.1/2.0 (Full speed)
Maximum supply current.....	500mA
File system.....	FAT16/32
MP3 decode.....	Compliant with MPEG-1/2 Audio Layer-3
WMA decode.....	Compliant with Windows Media Audio

### Audio section

Maximum output power.....	50W x 4
Full Bandwidth Power (at less than 1% THD).....	22W x 4
Speaker Impedance.....	4~8Ω
Tone action.....	
BAND1.....	60Hz~400Hz±9dB
BAND2.....	630Hz~2.5kHz±9dB
BAND3.....	4.0kHz~16kHz±9dB
Preout level/Load (CD).....	2500mV/10kΩ
Preout impedance.....	≤600Ω

### Auxiliary input

Frequency response (±1dB).....	20Hz~20kHz
Input Maximum Voltage.....	1200mV
Input Impedance.....	100kΩ

### General

Operating voltage (10.5~16V allowable).....	14.4V
Maximum current consumption.....	10A
Installation Size (W x H x D).....	182 x 53 x 155mm
.....	7-3/16 x 2-1/16 x 6-1/8inch
Weight.....	2.4lbs (1.2kg)

## ■ Models for destination “M”

### FM tuner section

Frequency range.....	
200kHz space.....	87.9MHz~107.9MHz
50kHz space.....	87.5MHz~108.0MHz
Usable sensitivity (S/N=30dB).....	9.3dBf (0.8μV/75Ω)
Quieting Sensitivity (S/N=50dB).....	15.2dBf (1.6μV/75Ω)
Frequency response (±3.0dB).....	30Hz~15kHz
Signal to Noise ratio (MONO).....	70dB
Selectivity (±400kHz).....	≥80dB
Stereo separation (1kHz).....	40dB

### AM tuner section

Frequency range.....	
10kHz space.....	530kHz~1700kHz
9kHz space.....	531kHz~1611kHz
Usable sensitivity (S/N=20dB).....	28dBμ (25μV)

### Bluetooth section

Version.....	Bluetooth Ver. 2.0 Certified
Frequency range.....	2.402GHz~2.480GHz
Output Power.....	+4dBm (MAX), 0dBm (AVE) Power Class 2
Maximum Communication range.....	Line of sight approx.10m (32.8ft)
Profiles.....	HFP (Hands Free Profile)
.....	HSP (Headset Profile)
.....	SPP (Serial Port Profile)
.....	PBAP (Phonebook Access Profile)
.....	OPP (Object Push Profile)
.....	SYNC (Synchronization Profile)

### CD player section

Laser diode.....	GaAIs
Digital filter (D/A).....	8 Times Over Sampling
D/A Converter.....	24Bit
Spindle speed.....	500~200rpm (CLV)
Wow & Flutter.....	Below Measurable Limit
Frequency response (±1dB).....	20Hz~20kHz
Total harmonic distortion (1kHz).....	0.01%
Signal to Noise ratio (1kHz).....	110dB
Dynamic range.....	93dB
MP3 decode.....	Compliant with MPEG-1/2 Audio Layer-3
WMA decode.....	Compliant with Windows Media Audio
AAC decode.....	AAC-LC “.m4a” files

### USB Interface

USB standard.....	USB1.1/2.0 (Full speed)
-------------------	-------------------------

## SPECIFICATIONS

Maximum supply current..... 500mA  
File system ..... FAT16/32  
MP3 decode..... Compliant with MPEG-1/2 Audio Layer-3  
WMA decode..... Compliant with Windows Media Audio  
AAC decode ..... AAC-LC “.m4a” files

### Audio section

Maximum output power ..... 50W x 4  
Full Bandwidth Power (at less than 1% THD) ..... 22W x 4  
Speaker Impedance ..... 4~8Ω  
Tone action  
Bass ..... 100Hz±8dB  
Middle ..... 1kHz±8dB  
Treble ..... 10kHz±8dB  
Preout level/Load (CD) ..... 2500mV/10kΩ  
Preout impedance ..... ≤600Ω

### Auxiliary input

Frequency response (±1dB) ..... 20Hz~20kHz  
Input Maximum Voltage..... 1200mV  
Input Impedance ..... 100kΩ

### General

Operating voltage (10.5~16V allowable)..... 14.4V  
Maximum current consumption ..... 10A  
Installation Size (W x H x D) ..... 182 x 53 x 155mm  
Weight ..... 1.2kg

## ■ Models for destination “E”

### FM tuner section

Frequency range (50kHz space)..... 87.5MHz~108.0MHz  
Usable sensitivity (S/N=26dB)..... 0.7μV/75Ω  
Quieting Sensitivity (S/N=46dB)..... 1.6μV/75Ω  
Frequency response (±3.0dB) ..... 30Hz~15kHz  
Signal to Noise ratio (MONO)..... 65dB  
Selectivity (DIN) (±400kHz) ..... ≥80dB  
Stereo separation (1kHz)..... 35dB

### MW tuner section

Frequency range (9kHz space)..... 531kHz~1611kHz  
Usable sensitivity (S/N=20dB)..... 25μV

### LW tuner section

Frequency range ..... 153kHz~281kHz  
Usable sensitivity (S/N=20dB)..... 45μV

### Bluetooth section

Version..... Bluetooth Ver. 2.0 Certified  
Frequency range ..... 2.402GHz~2.480GHz  
Output Power ..... +4dBm (MAX), 0dBm (AVE) Power Class 2

### Maximum Communication range

..... Line of sight approx. 10m (32.8ft)  
Profiles..... HFP (Hands Free Profile)  
..... HSP (Headset Profile)  
..... SPP (Serial Port Profile)  
..... PBAP (Phonebook Access Profile)  
..... OPP (Object Push Profile)  
..... SYNC (Synchronization Profile)

### CD player section

Laser diode..... GaAlAs  
Digital filter (D/A)..... 8 Times Over Sampling  
D/A Converter..... 24Bit  
Spindle speed ..... 500~200rpm (CLV)  
Wow & Flutter ..... Below Measurable Limit  
Frequency response (±1dB) ..... 20Hz~20kHz  
Total harmonic distortion (1kHz)..... 0.01%  
Signal to Noise ratio (1kHz)..... 110dB  
Dynamic range ..... 93dB  
MP3 decode..... Compliant with MPEG-1/2 Audio Layer-3  
WMA decode..... Compliant with Windows Media Audio  
AAC decode ..... AAC-LC “.m4a” files

### USB Interface

USB standard ..... USB1.1/2.0 (Full speed)  
Maximum supply current..... 500mA  
File system ..... FAT16/32  
MP3 decode..... Compliant with MPEG-1/2 Audio Layer-3  
WMA decode..... Compliant with Windows Media Audio  
AAC decode ..... AAC-LC “.m4a” files

### Audio section

Maximum output power ..... 50W x 4  
Output power (DIN 45324, +B=14.4V) ..... 22W x 4  
Speaker Impedance ..... 4~8Ω  
Tone action  
BAND1 ..... 60Hz~400Hz±9dB  
BAND2 ..... 630Hz~2.5kHz±9dB  
BAND3 ..... 4.0kHz~16kHz±9dB  
Preout level/Load (CD) ..... 2500mV/10kΩ  
Preout impedance ..... ≤600Ω

### Auxiliary input

Frequency response (±1dB) ..... 20Hz~20kHz  
Input Maximum Voltage..... 1200mV  
Input Impedance ..... 100kΩ

### General

Operating voltage (10.5~16V allowable)..... 14.4V  
Maximum current consumption ..... 10A  
Installation Size (W x H x D) ..... 182 x 53 x 155mm  
Weight ..... 1.2kg

#### DANGER:

Please do not look at the laser beam directly during repair or operation check.

KENWOOD follows a policy of continuous advancements in development. For this reason specifications may be changed without notice.

