

iW1710 Product Brief

Digital PWM Current-Mode Controller for Quasi-Resonant Operation



1.0 Features

- Primary-side feedback eliminates opto-isolators and simplifies design
- Quasi-resonant operation for highest overall efficiency
- **EZ-EMI**® design to easily meet global EMI standards
- Up to 130 kHz switching frequency enables small adapter size
- Very tight output voltage regulation
- No external compensation components required
- Complies with CEC/EPA no-load power consumption and average efficiency regulations
- Built-in output constant-current control with primary-side feedback
- Low start-up current (10 μ A typical)
- Built-in soft start
- Built-in short circuit protection and output overvoltage protection
- Optional AC line under/overvoltage protection
- PFM operation at light load
- Current sense resistor short protection
- Overtemperature Protection

2.0 Description

The iW1710 is a high performance AC/DC power supply controller which uses digital control technology to build peak current mode PWM flyback power supplies. The device operates in quasi-resonant mode at heavy load to provide high efficiency along with a number of key built-in protection features while minimizing the external component count, simplifying EMI design and lowering the total bill of material cost. The iW1710 removes the need for secondary feedback circuitry while achieving excellent line and load regulation. It also eliminates the need for loop compensation components while maintaining stability over all operating conditions. Pulse-by-pulse waveform analysis allows for a loop response that is much faster than traditional solutions, resulting in improved dynamic load response. The built-in current limit function enables optimized transformer design in universal off-line applications over a wide input voltage range.

The ultra-low operating current at light load ensures that the iW1710 is ideal for applications targeting the newest regulatory standards for average efficiency and standby power.

3.0 Applications

- Cable/DSL modems, WLAN access points and VOIP gateways.

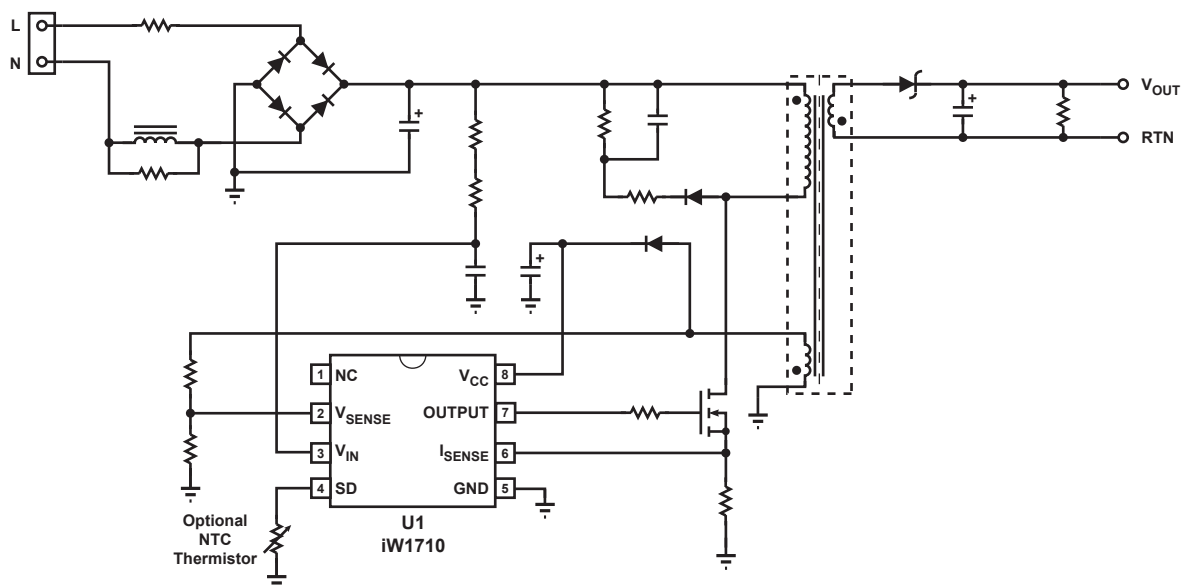

Figure 3.1 : Typical Application Circuit

iW1710 Product Brief

Digital PWM Current-Mode Controller for Quasi-Resonant Operation



4.0 Pinout Description

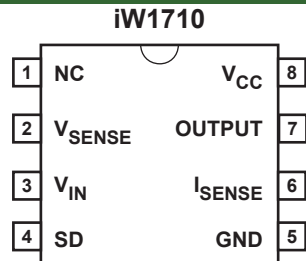

Pin #	Name	Type	Pin Description
1	NC	-	No connection.
2	V _{SENSE}	Analog Input	Auxiliary voltage sense (used for primary side regulation).
3	V _{IN}	Analog Input	Rectified AC line average voltage sense.
4	SD	Analog Input	External shutdown control. Connect to ground through a resistor if not used.
5	GND	Ground	Ground.
6	I _{SENSE}	Analog Input	Primary current sense (used for cycle-by-cycle peak current control and limit).
7	OUTPUT	Output	Gate drive for external MOSFET switch.
8	V _{CC}	Power Input	Power supply for control logic and voltage sense for power-on reset circuitry.

5.0 Absolute Maximum Ratings

Absolute maximum ratings are the parameter values or ranges which can cause permanent damage if exceeded. For maximum safe operating conditions, refer to the iW1710 Datasheet.

Parameter	Symbol	Value	Units
DC supply voltage range (pin 8, I _{CC} = 20mA max)	V _{CC}	-0.3 to 18	V
DC supply current at V _{CC} pin	I _{CC}	20	mA
Output (pin 7)		-0.3 to 18	V
V _{SENSE} input (pin 2, I _{Vsense} ≤ 10 mA)		-0.7 to 4.0	V
V _{IN} input (pin 3)		-0.3 to 18	V
I _{SENSE} input (pin 6)		-0.3 to 4.0	V
SD input (pin 4)		-0.3 to 18	V
Power dissipation at T _A ≤ 25°C	P _D	526	mW
Maximum junction temperature	T _{J MAX}	125	°C
Storage temperature	T _{STG}	-65 to 150	°C
Thermal Resistance Junction-to-Ambient	θ _{JA}	160	°C/W
ESD rating per JEDEC JESD22-A114		2,000	V
Latch-Up test per JEDEC 78		±100	mA

iW1710 Product Brief

Digital PWM Current-Mode Controller for Quasi-Resonant Operation



6.0 Physical Dimensions

8-Lead Small Outline (SOIC) Package

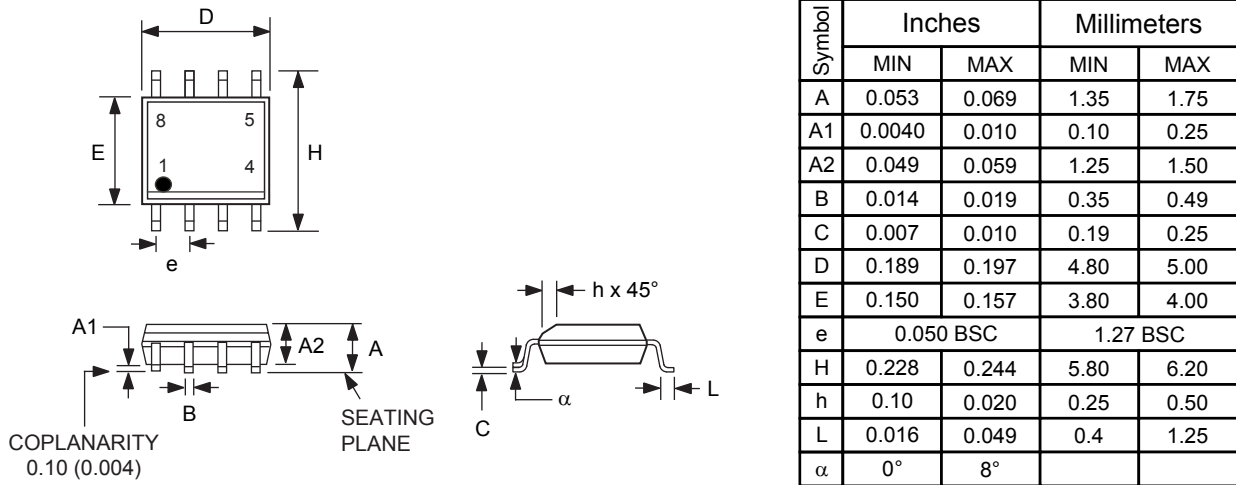

Figure 6.1 : Physical dimensions, 8-lead SOIC package

Compliant to JEDEC Standard MS12F

Controlling dimensions are in inches; millimeter dimensions are for reference only

This product is RoHS compliant and Halide free.

Soldering Temperature Resistance:

[a] Package is IPC/JEDEC Std 020D Moisture Sensitivity Level 1

[b] Package exceeds JEDEC Std No. 22-A111 for Solder Immersion Resistance; package can withstand 10 s immersion < 270°C

Dimension D does not include mold flash, protrusions or gate burrs. Mold flash, protrusions or gate burrs shall not exceed 0.15 mm per end. Dimension E1 does not include interlead flash or protrusion. Interlead flash or protrusion shall not exceed 0.25 mm per side.

The package top may be smaller than the package bottom. Dimensions D and E1 are determined at the outermost extremes of the plastic body exclusive of mold flash, tie bar burrs, gate burrs and interlead flash, but including any mismatch between the top and bottom of the plastic body.

7.0 Ordering Information

Part Number	Options	Package	Description
iW1710-01	Cable Comp = 0 mV	SOIC-8	Tape & Reel ¹
iW1710-21	Cable Comp = 300 mV	SOIC-8	Tape & Reel ¹

Note 1: Tape & Reel packing quantity is 2,500/reel.

iW1710 Product Brief

Digital PWM Current-Mode Controller for Quasi-Resonant Operation



Trademark Information

© 2012 iWatt Inc. All rights reserved. iWatt, BroadLED, *EZ-EMI*, Flickerless, Intelligent AC-DC and LED Power, and PrimAccurate are trademarks of iWatt Inc. All other trademarks and registered trademarks are the property of their respective owners.

Contact Information

Web: <https://www.iwatt.com>

E-mail: info@iwatt.com

Phone: +1 (408) 374-4200

Fax: +1 (408) 341-0455

iWatt Inc.

675 Campbell Technology Parkway, Suite 150
Campbell, CA 95008

Disclaimer and Legal Notices

iWatt reserves the right to make changes to its products and to discontinue products without notice. The applications information, schematic diagrams, and other reference information included herein is provided as a design aid only and are therefore provided as-is. iWatt makes no warranties with respect to this information and disclaims any implied warranties of merchantability or non-infringement of third-party intellectual property rights.

This product is covered by the following patents: 6,385,059; 6,730,039; 6,862,198; 6,900,995; 6,956,750; 6,990,900; 7,443,700; 7,505,287; 7,589,983; 6,972,969; 7,724,547; 7,876,582; 7,880,447; 7,974,109; 8,018,743; 8,049,481. A full list of iWatt patents can be found at www.iwatt.com.

Certain applications using semiconductor products may involve potential risks of death, personal injury, or severe property or environmental damage ("Critical Applications").

iWATT SEMICONDUCTOR PRODUCTS ARE NOT DESIGNED, INTENDED, AUTHORIZED, OR WARRANTED TO BE SUITABLE FOR USE IN LIFE-SUPPORT APPLICATIONS, DEVICES OR SYSTEMS, OR OTHER CRITICAL APPLICATIONS.

Inclusion of iWatt products in critical applications is understood to be fully at the risk of the customer. Questions concerning potential risk applications should be directed to iWatt Inc.

iWatt semiconductors are typically used in power supplies in which high voltages are present during operation. High-voltage safety precautions should be observed in design and operation to minimize the chance of injury.