



P-Channel Enhancement Mode Field Effect Transistor

PRODUCT SUMMARY		
V _{DSS}	I _D	R _{DS(ON)} (mΩ) Max
-30V	-24A	28 @ V _{GS} = -10V
		40 @ V _{GS} = -4.5V

FEATURES

- Super high dense cell design for low R_{DS(ON)}.
- Rugged and reliable.
- Surface Mount Package.
- ESD Protected

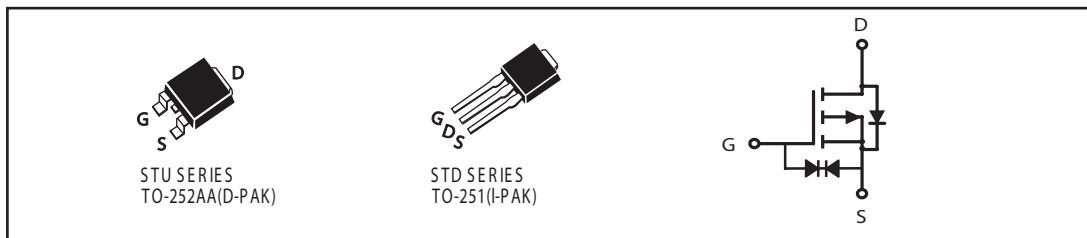

ABSOLUTE MAXIMUM RATINGS (T_A=25°C unless otherwise noted)

Parameter	Symbol	Limit	Unit
Drain-Source Voltage	V _{DS}	-30	V
Gate-Source Voltage	V _{GS}	±20	V
Drain Current-Continuous @ T _c =25°C -Pulsed ^a	I _D	-24	A
	I _{DM}	-96	A
Drain-Source Diode Forward Current	I _S	-20	A
Maximum Power Dissipation @ T _c =25°C	P _D	50	W
Operating Junction and Storage Temperature Range	T _J , T _{STG}	-55 to 175	°C

THERMAL CHARACTERISTICS

Thermal Resistance, Junction-to-Case	R _{θJC}	3	°C/W
Thermal Resistance, Junction-to-Ambient	R _{θJA}	50	°C/W

STU/D303S

ELECTRICAL CHARACTERISTICS ($T_c=25^{\circ}\text{C}$ unless otherwise noted)

Parameter	Symbol	Condition	Min	Typ ^c	Max	Unit	
OFF CHARACTERISTICS							
Drain-Source Breakdown Voltage	BV_{DSS}	$V_{GS}=0V, I_D=-250\mu A$	-30			V	
Zero Gate Voltage Drain Current	I_{DSS}	$V_{DS}=-20V, V_{GS}=0V$			-1	μA	
Gate-Body Leakage	I_{GSS}	$V_{GS}=\pm 20V, V_{DS}=0V$			± 10	μA	
ON CHARACTERISTICS^a							
Gate Threshold Voltage	$V_{GS(th)}$	$V_{DS}=V_{GS}, I_D=-250\mu A$	-1	-1.8	-3	V	
Drain-Source On-State Resistance	$R_{DS(ON)}$	$V_{GS}=-10V, I_D=-12A$		23	28	m ohm	
		$V_{GS}=-4.5V, I_D=-6A$		34	40	m ohm	
On-State Drain Current	$I_{D(ON)}$	$V_{DS}=-10V, V_{GS}=-10V$	-30			A	
Forward Transconductance	g_{FS}	$V_{DS}=-10V, I_D=-10A$		11.5		S	
DYNAMIC CHARACTERISTICS^b							
Input Capacitance	C_{ISS}	$V_{DS}=-15V, V_{GS}=0V$ $f=1.0MHz$		1130		pF	
Output Capacitance	C_{OSS}			270		pF	
Reverse Transfer Capacitance	C_{RSS}			170		pF	
SWITCHING CHARACTERISTICS^b							
Turn-On Delay Time	$t_{D(ON)}$	$V_{DD}=-15V$ $I_D=-1A$ $V_{GS}=-10V$ $R_{GEN}=6\text{ ohm}$		19		ns	
Rise Time	t_r			31		ns	
Turn-Off Delay Time	$t_{D(OFF)}$			100		ns	
Fall Time	t_f			28		ns	
Total Gate Charge (10V)	Q_g	$V_{DS}=-15V, I_D=-12A$ $V_{GS}=-10V$		22		nC	
Total Gate Charge (4.5V)				10.6		nC	
Gate-Source Charge			Q_{gs}		2.7		nC
Gate-Drain Charge			Q_{gd}		6.4		nC

STU/D303S

ELECTRICAL CHARACTERISTICS ($T_c=25^\circ\text{C}$ unless otherwise noted)

Parameter	Symbol	Condition	Min	Typ	Max	Unit
DRAIN-SOURCE DIODE CHARACTERISTICS ^a						
Diode Forward Voltage	V_{SD}	$V_{GS} = 0V, I_s = -10A$		-0.88	-1.3	V

Notes

- a. Pulse Test: Pulse Width $\leq 300\mu s$, Duty Cycle $\leq 2\%$.
- b. Guaranteed by design, not subject to production testing.

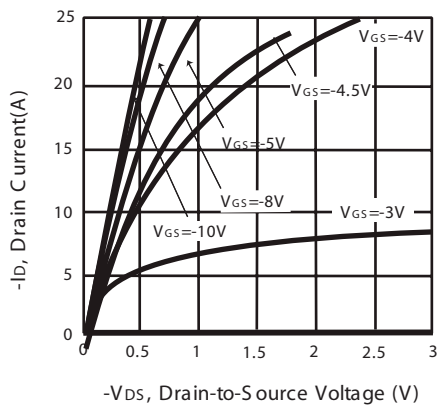

Figure 1. Output Characteristics

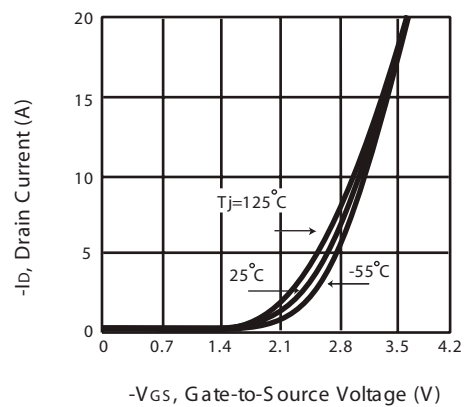

Figure 2. Transfer Characteristics

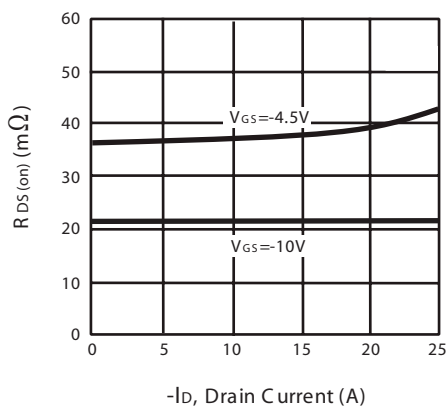

Figure 3. On-Resistance vs. Drain Current and Gate Voltage

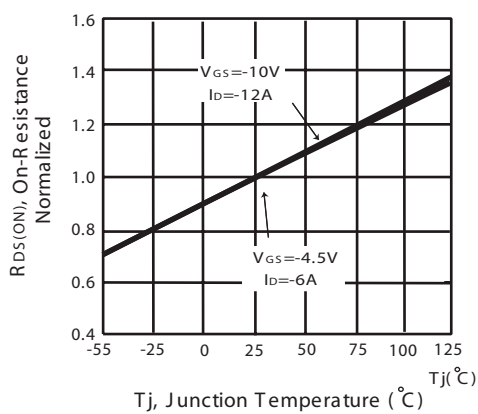

Figure 4. On-Resistance Variation with Drain Current and Temperature

STU/D303S

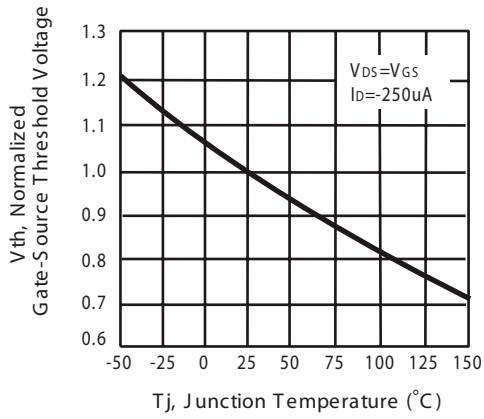

Figure 5. Gate Threshold Variation with Temperature

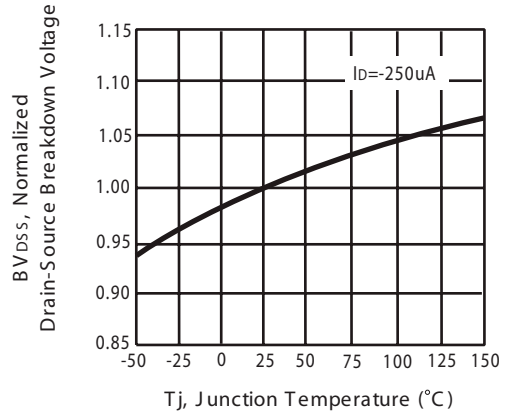

Figure 6. Breakdown Voltage Variation with Temperature

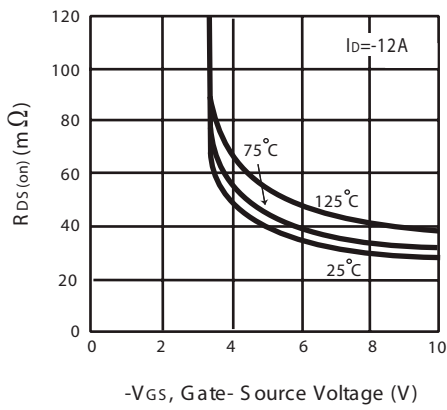

Figure 7. On-Resistance vs. Gate-Source Voltage

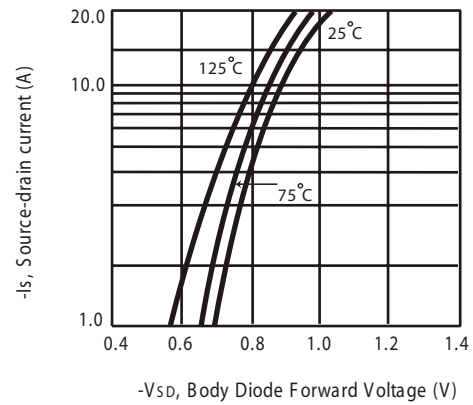

Figure 8. Body Diode Forward Voltage Variation with Source Current

STU/D303S

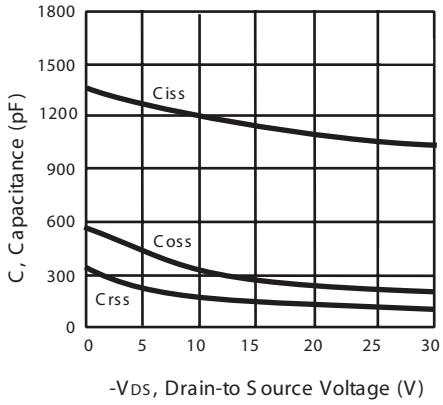

Figure 9. Capacitance

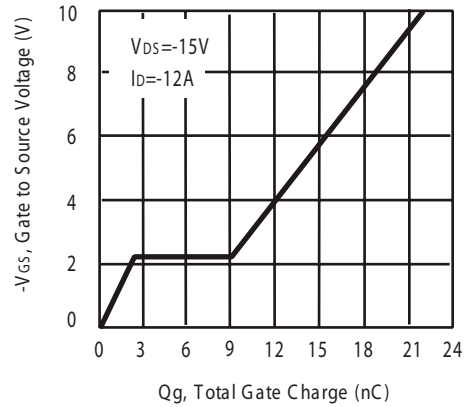

Figure 10. Gate Charge

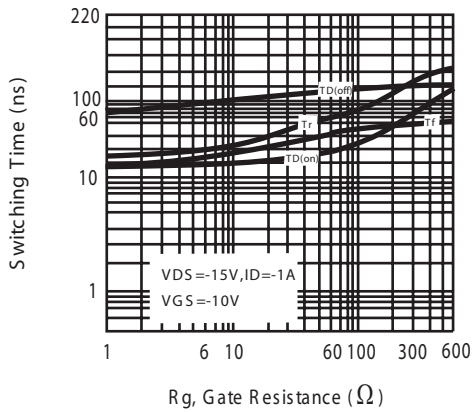

Figure 11. switching characteristics

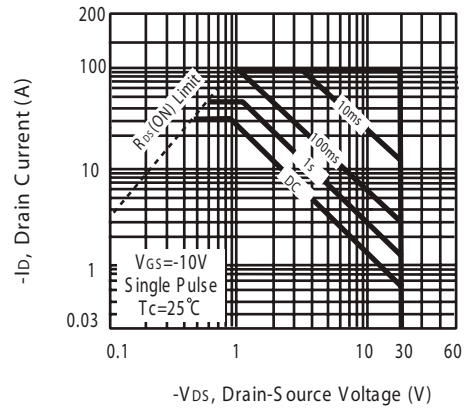

Figure 12. Maximum Safe Operating Area

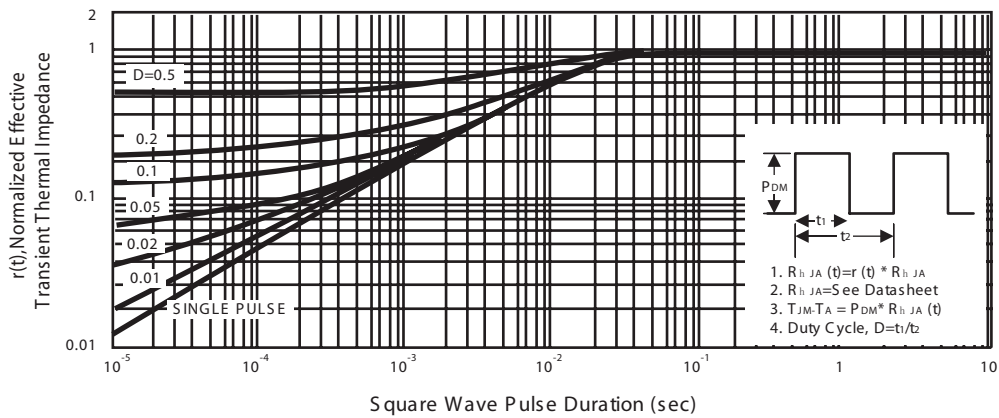
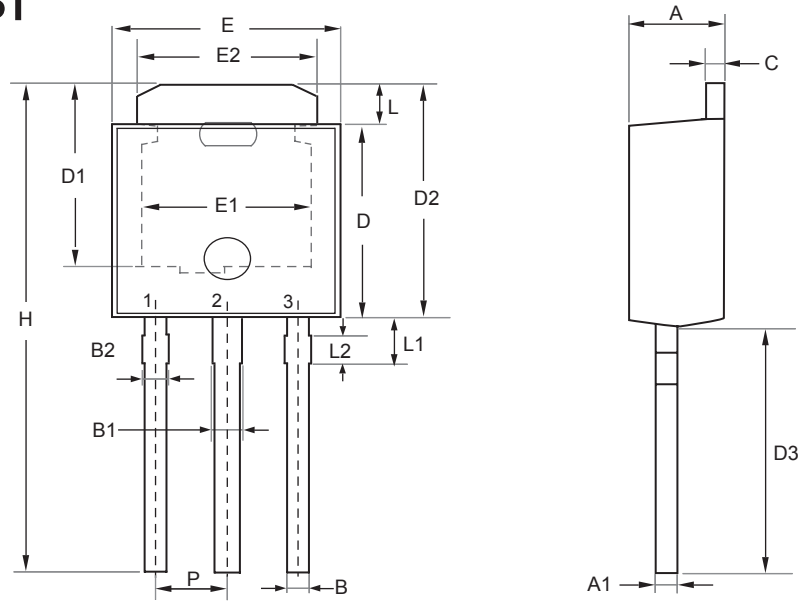

Figure 13. Normalized Thermal Transient Impedance Curve

STU/D303S

PACKAGE OUTLINE DIMENSIONS

TO-251



SYMBOL	MILLIMETERS		INCHES	
	MIN	MAX	MIN	MAX
A	2.100	2.500	0.083	0.098
A1	0.350	0.650	0.014	0.026
B	0.400	0.800	0.016	0.031
B1	0.650	1.050	0.026	0.041
B2	0.500	0.900	0.020	0.035
C	0.400	0.600	0.016	0.024
D	5.300	5.700	0.209	0.224
D1	4.900	5.300	0.193	0.209
D2	6.700	7.300	0.264	0.287
D3	7.000	8.000	0.276	0.315
H	13.700	15.300	0.539	0.602
E	6.300	6.700	0.248	0.264
E1	4.600	4.900	0.181	0.193
E2	4.800	5.200	0.189	0.205
L	1.300	1.700	0.051	0.067
L1	1.400	1.800	0.055	0.071
L2	0.500	0.900	0.020	0.035
P	2.300 BSC		0.091 BSC	

STU/D303S

PACKAGE OUTLINE DIMENSIONS

TO-252

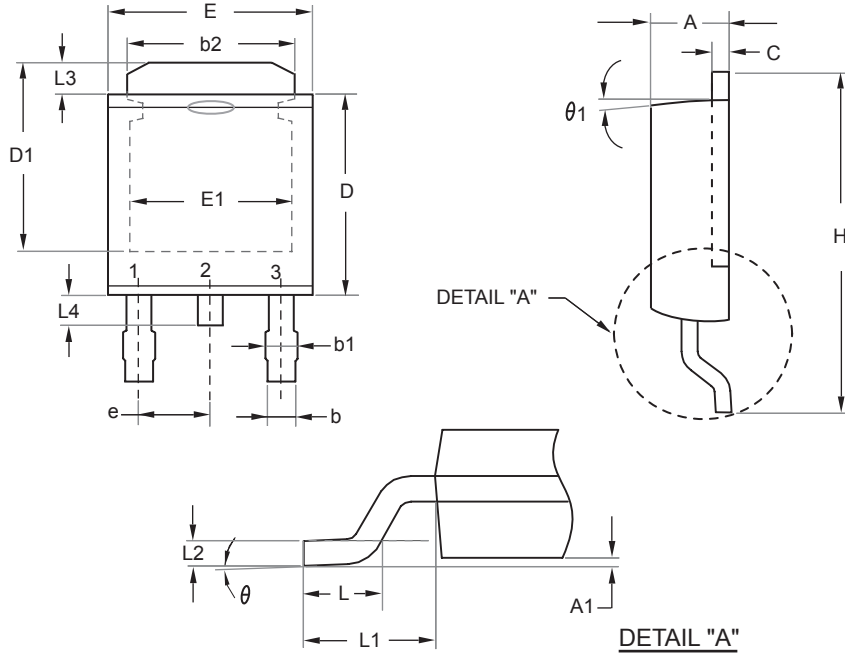

SYMBOLS	MILLIMETERS		INCHES	
	MIN	MAX	MIN	MAX
A	2.100	2.500	0.083	0.098
A1	0.000	0.200	0.000	0.008
b	0.400	0.889	0.016	0.035
b1	0.770	1.140	0.030	0.045
b2	4.800	5.460	0.189	0.215
C	0.400	0.600	0.016	0.024
D	5.300	6.223	0.209	0.245
D1	4.900	5.515	0.193	0.217
E	6.300	6.731	0.248	0.265
E1	4.400	5.004	0.173	0.197
e	2.290 REF		0.090 BSC	
H	8.900	10.400	0.350	0.409
L	1.397	1.770	0.055	0.070
L1	2.743 REF.		0.108 REF.	
L2	0.508 REF.		0.020 REF.	
L3	0.890	1.700	0.035	0.067
L4	0.500	1.100	0.020	0.043
θ	0°	10°	0°	10°
θ_1	7° REF.		7° REF.	

STU/D303S

TO251 Tube/TO-252 Tape and Reel Data

TO-251 Tube

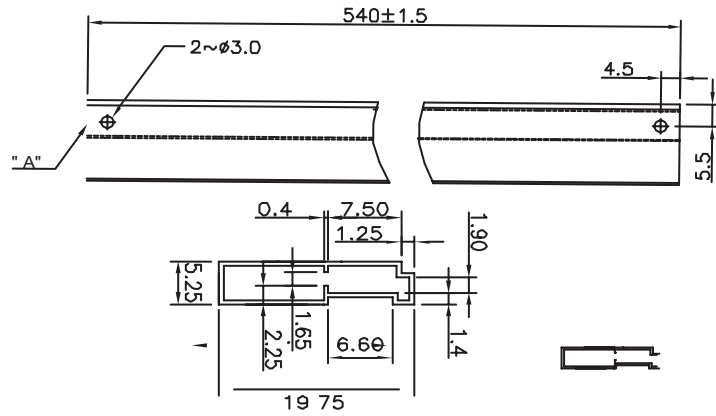

TO-252 Carrier Tape

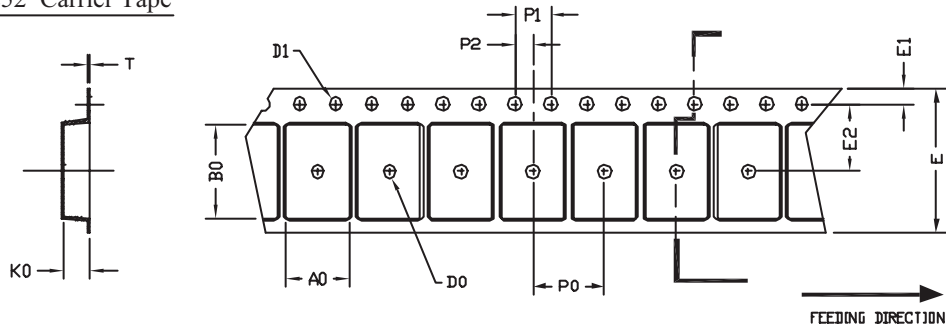

UNIT:mm

PACKAGE	A0	B0	K0	D0	D1	E	E1	E2	P0	P1	P2	T
TO-252 (16 mm)	6.80 ±0.1	10.3 ±0.1	2.50 ±0.1	φ 2	φ 1.5 + 0.1 - 0	16.0 0.3±	1.75 0.1±	7.5 ±0.15	8.0 ±0.1	4.0 ±0.1	2.0 ±0.15	0.3 ±0.05

TO-252 Reel

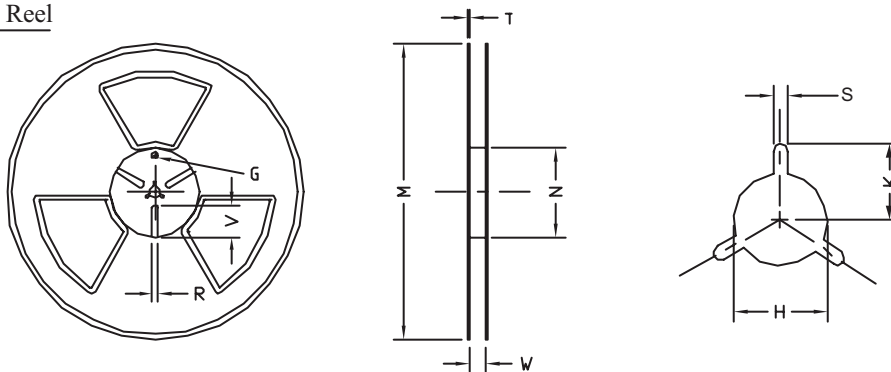

UNIT:mm

TAPE SIZE	REEL SIZE	M	N	W	T	H	K	S	G	R	V
16 mm	φ 330	φ 330 ± 0.5	φ 97 ± 1.0	17.0 + 1.5 - 0	2.2	φ 13.0 + 0.5 - 0.2	10.6	2.0 ±0.5	---	---	---