

WIRING DIAGRAM - SCHEMA D'INTERCONNESSIONI - VERDRÄHTUNGSPLAN - DIAGRAMMA DELLE INTERCONNESSIONI - ESQUEMA DE INTERCONEXIONES

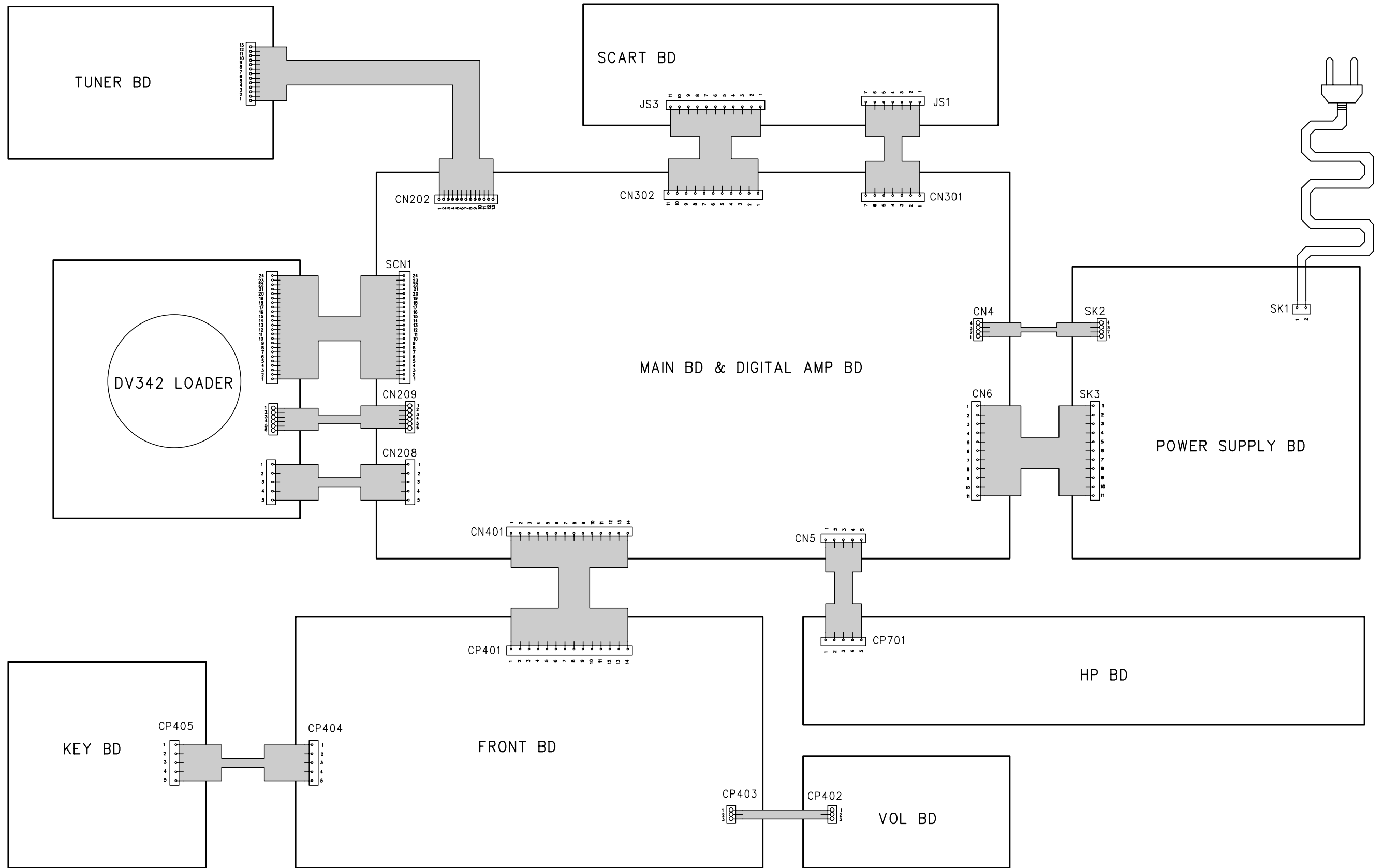

BLOCK DIAGRAM - SCHEMA SYNOPTIQUE - BLOCKSCHALTBILD - SCHEMA A BLOCCHI - ESQUEMA DE BLOQUES

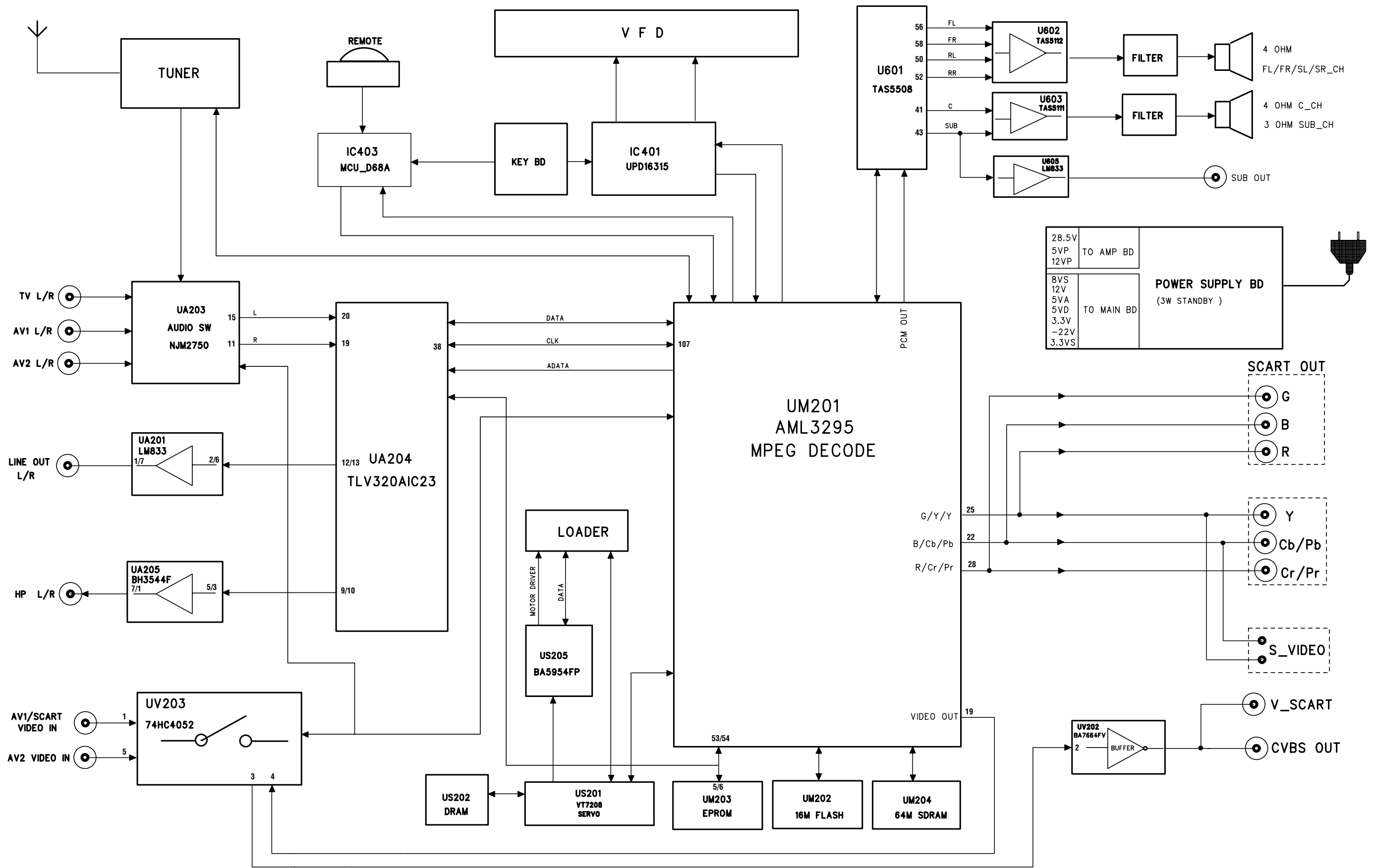

MAIN SCHEMATIC DIAGRAM - SCHEMA DE LA PLATINE PRINCIPALE - GRUNDPLATTE SCHALTBILD - SCHEMA DELLA PIASTRA PRINCIPALE- ESQUEMA DE LA PLATINA PRINCIPAL (1/5)

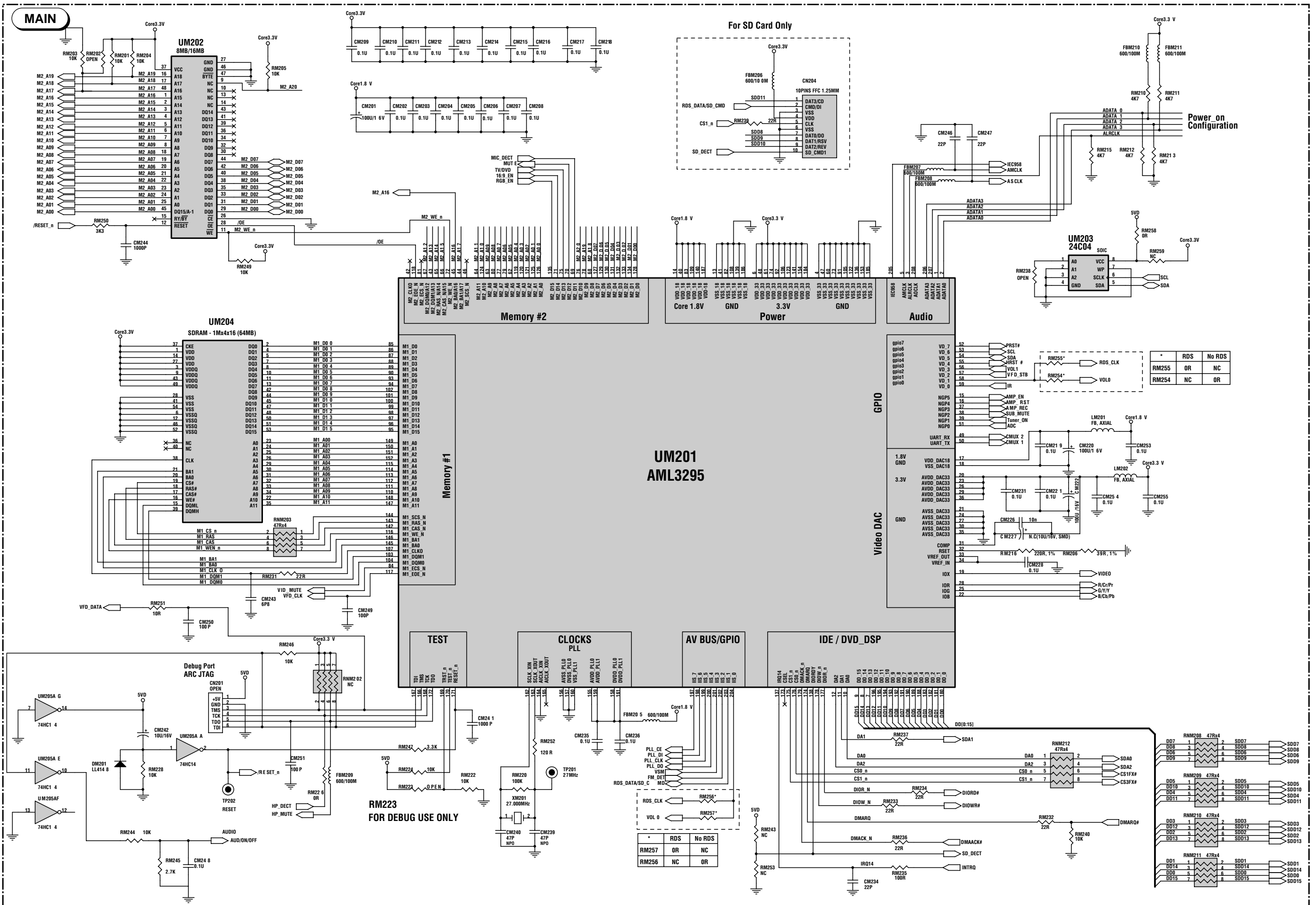

MAIN SCHEMATIC DIAGRAM - SCHEMA DE LA PLATINE PRINCIPALE - GRUNDPLATTE SCHALTBILD - SCHEMA DELLA PIASTRA PRINCIPALE- ESQUEMA DE LA PLATINA PRINCIPAL (2/5)

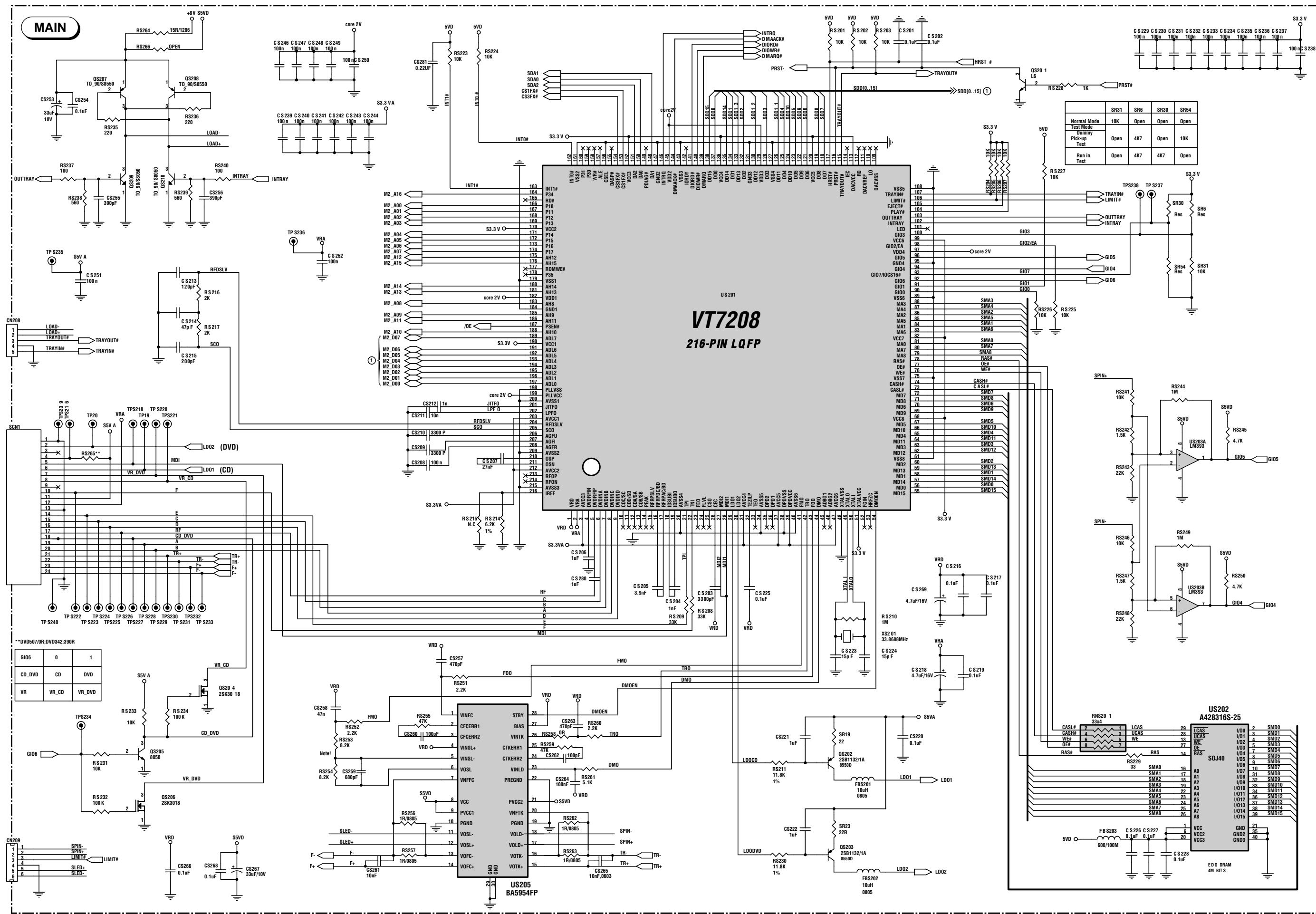

MAIN SCHEMATIC DIAGRAM - SCHEMA DE LA PLATINE PRINCIPALE - GRUNDPLATTE SCHALTBILD - SCHEMA DELLA PIASTRA PRINCIPALE - ESQUEMA DE LA PLATINA PRINCIPAL (3/5)

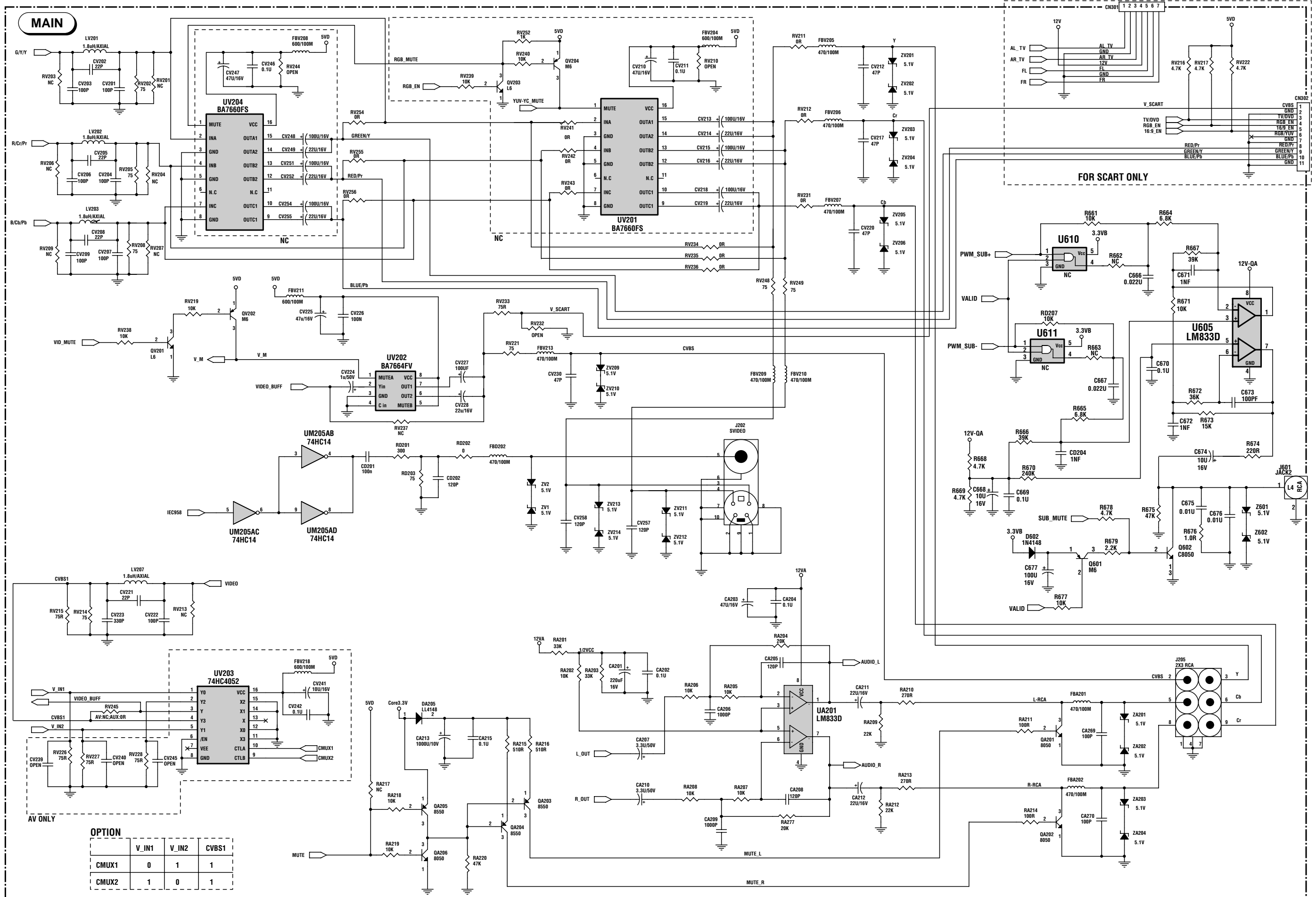

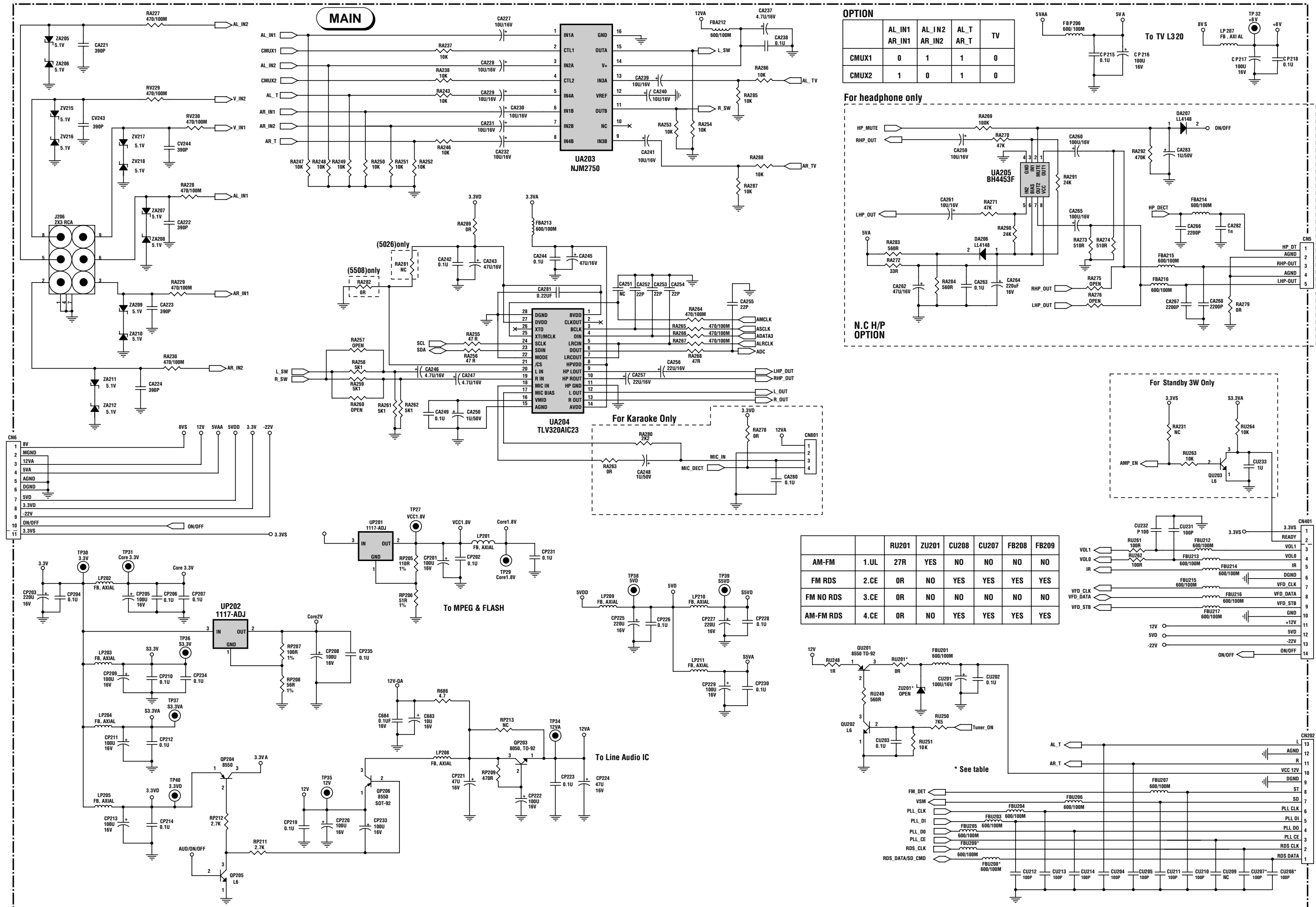

MAIN SCHEMATIC DIAGRAM - SCHEMA DE LA PLATINE PRINCIPALE - SCHALTBILD GRUNDPLATTE - SCHEMA DELLA PIASTRA PRINCIPALE- ESQUEMA DE LA PLATINA PRINCIPAL (5/5)

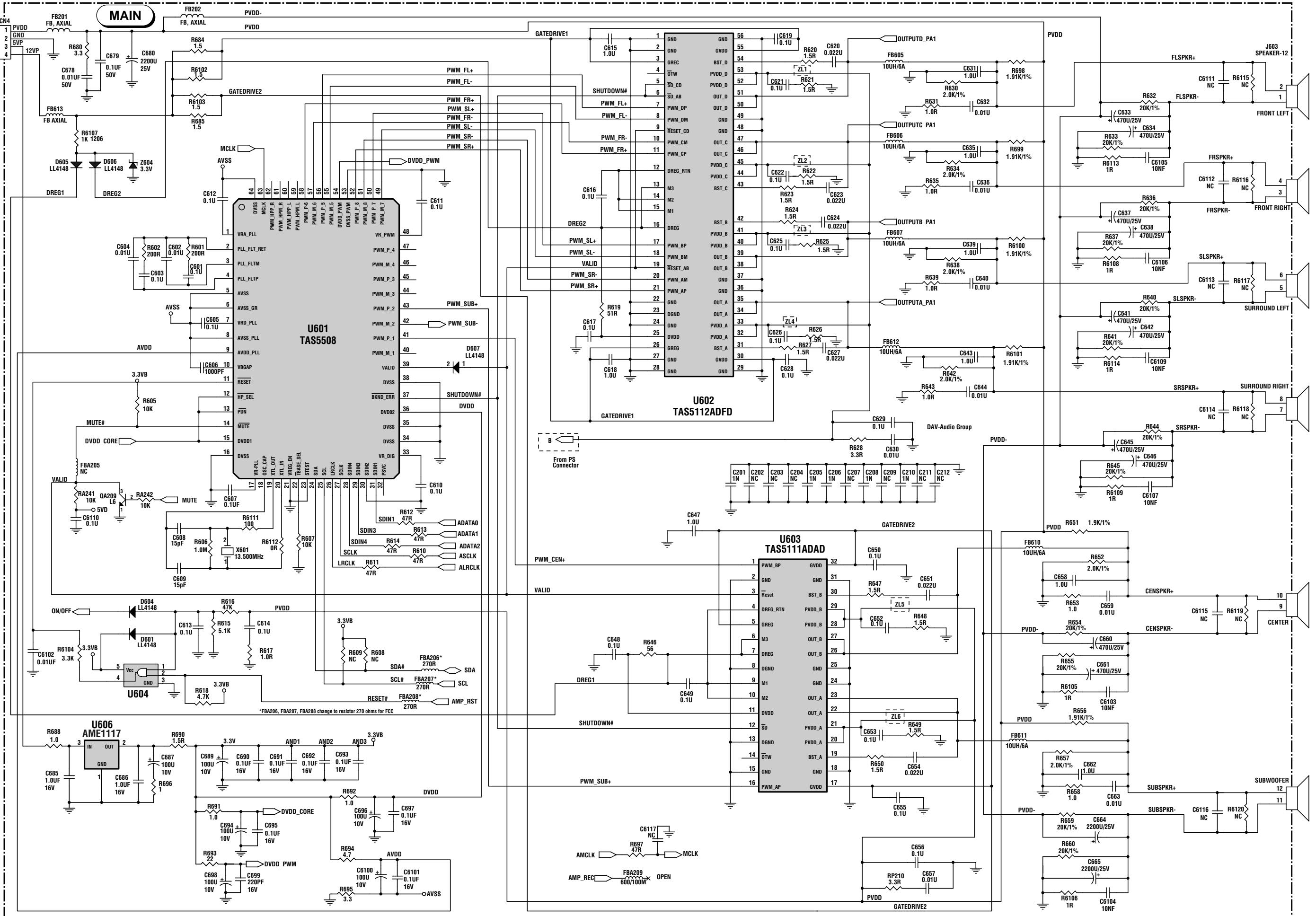

SCART INTERFACE SCHEMATIC DIAGRAM - SCHEMA D'INTERFACE PERITELEVISION - SCHALTBILD SCART INTERFACE - SCHEMA DEI INTERFACCIA PERITEL - ESQUEMA DEL INTERFACE EUROTOMA

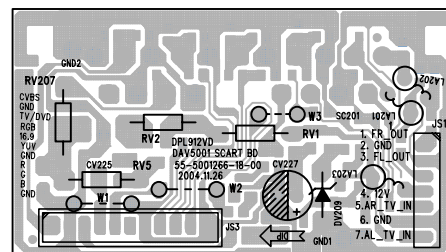
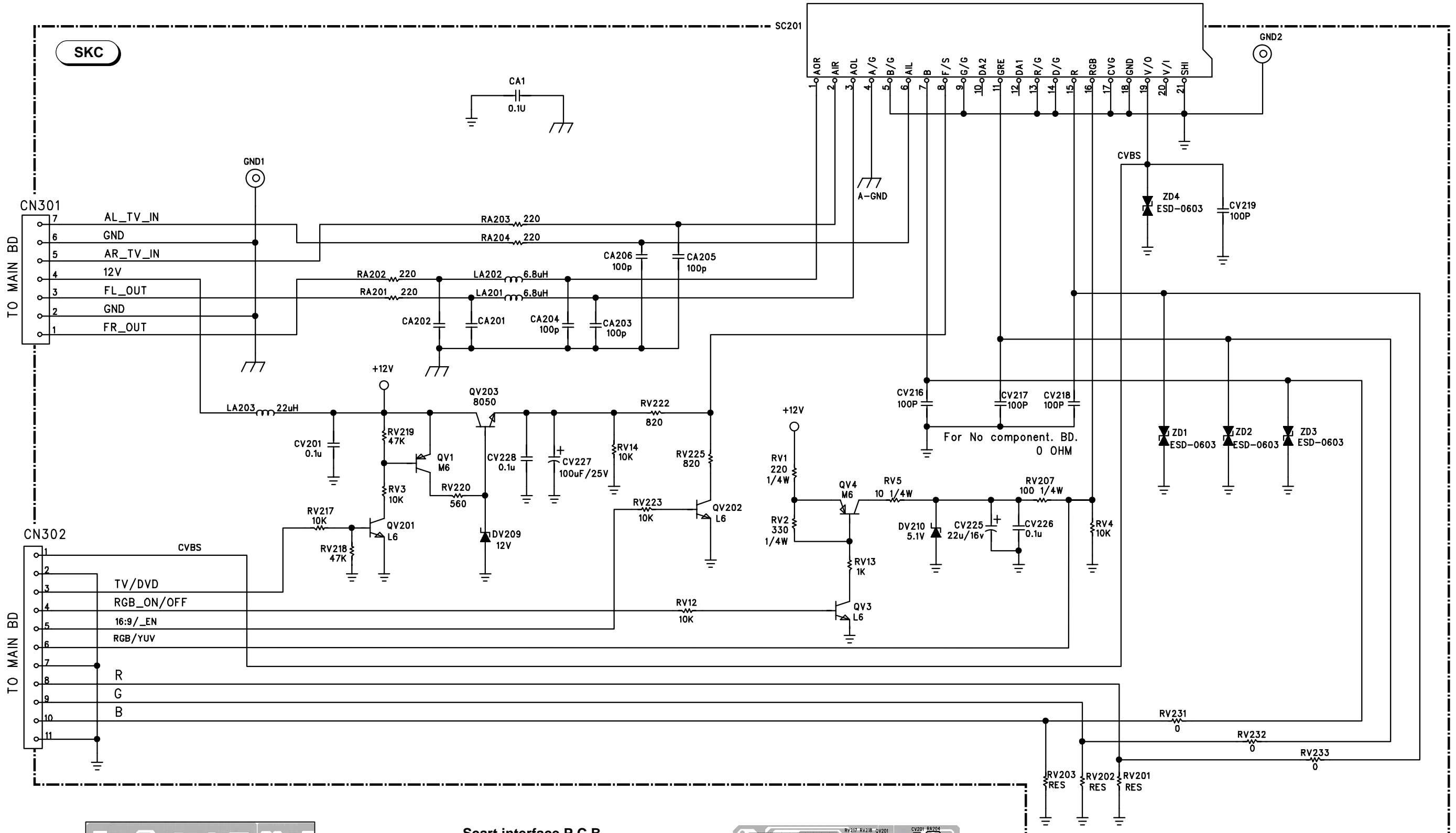

Solder side
Côté cuivre
Lötseite
Lato saldature
Lado del cobre

Scart interface P.C.B.
Platine interface peritélévision
Ltpl. Scart interface
Piastra interfaccia peritel
Platina eurotoma

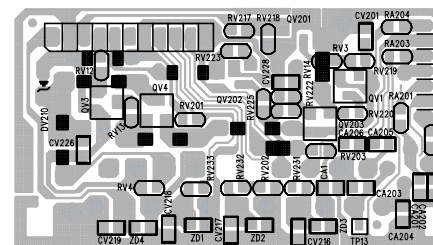

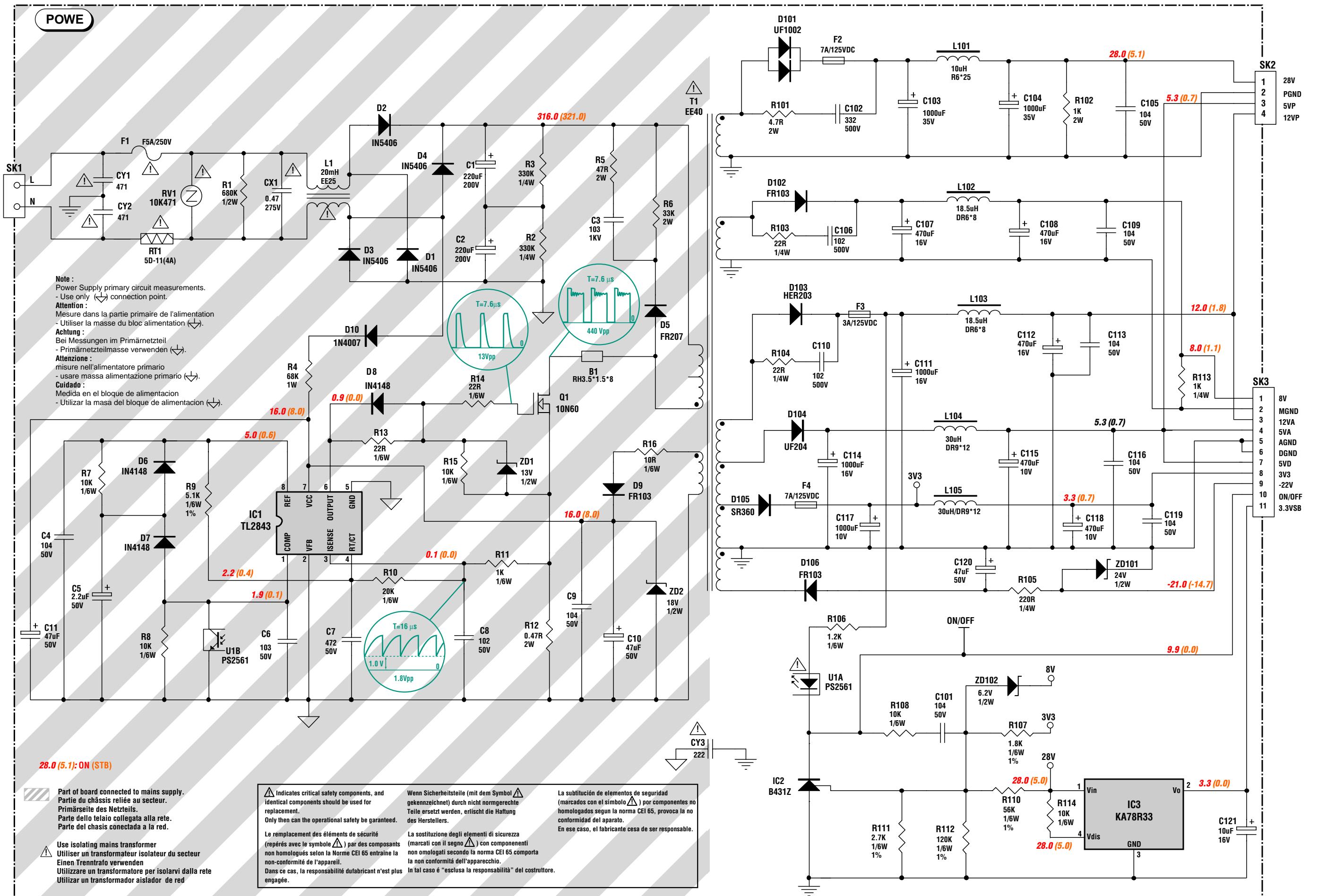

CONTROL / DISPLAY SCHEMATIC DIAGRAM - SCHEMA COMMANDES / AFFICHEUR - BEDIENTEIL / ANZEIGE SCHALTBILD - SCHEMA COMANDI / INDICATORE - ESQUEMA MANDOS / INDICADOR

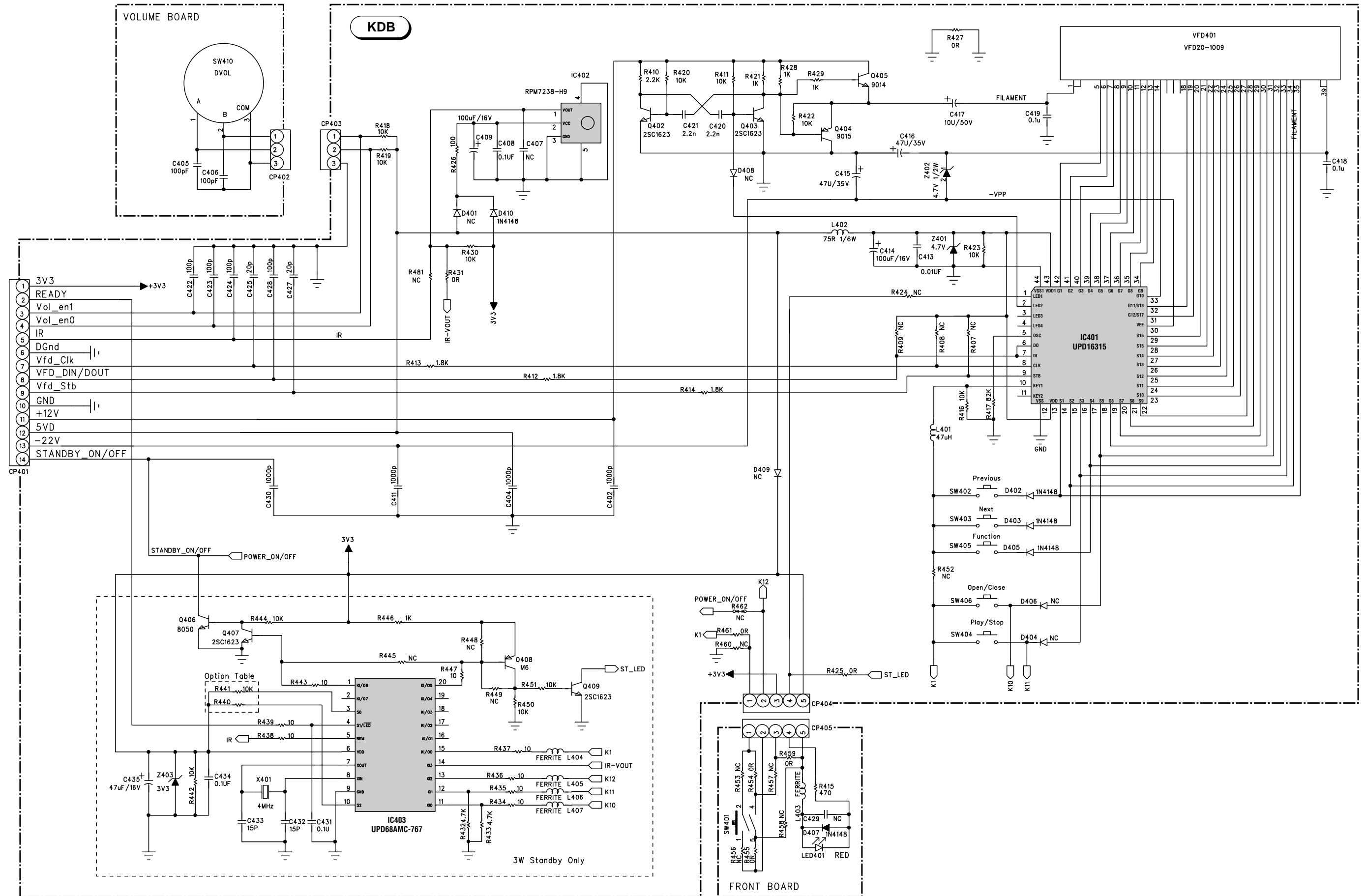

Abbreviations - Abreviations - Abkürzungen - Abbreviazioni - Abreviaciones

AC	Alternating Current	GCA	Gain Controlled Amplifier
ACC	Automatic Colour Control	HPF	High Pass Filter
AGC	Automatic Gain Control	I.R	Infra Red
A_IF	Audio IF	ID	Identification
ALC	Automatic Level Control	INP/IN	Input
AMP	Amplifier	KDB	Key Display Board
APC	Automatic Phase Control	LIM	Limiter
AV	Audio-Video	LPF	Low Pass Filter
BPF	Band Pass Filter	PCB	Printed Circuit Board
CH	Channel	PG	Pulse Generator
CLK	Clock	PLL	Phase Locked Loop
COMP	Comparator	PWM	Pulse Width Modulation
CONV	Converter	SCL	Serial Clock
CSYNC	Composite Synch	SDA	Serial Data
CTL	Control	SMPS	Switch Mode Power Supply
DC	Direct Current	SW	Switch
DET	Detector	VCA	Voltage Controlled Amplifier
DIG	Digital	VCO	Voltage Controlled Oscillator
ENV	Envelope	VD	Supply Voltage Digital
EQ	Equalizer	VE	Voltage (Ever)
FG	Frequency Generator	VS	Voltage (Switched)
GND	Ground		

HEADPHONE JACK SCHEMATIC DIAGRAM - SCHEMA DE LA PLATINE PRISE CASQUE - SCHALTBILD KOPFHÖRERBUSCHSE - SCHEMA DELLA PIASTRA PRESA PER CUFFIA - ESQUEMA DE LA PLATINA TOMA AURICULARES

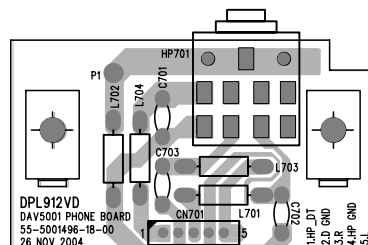
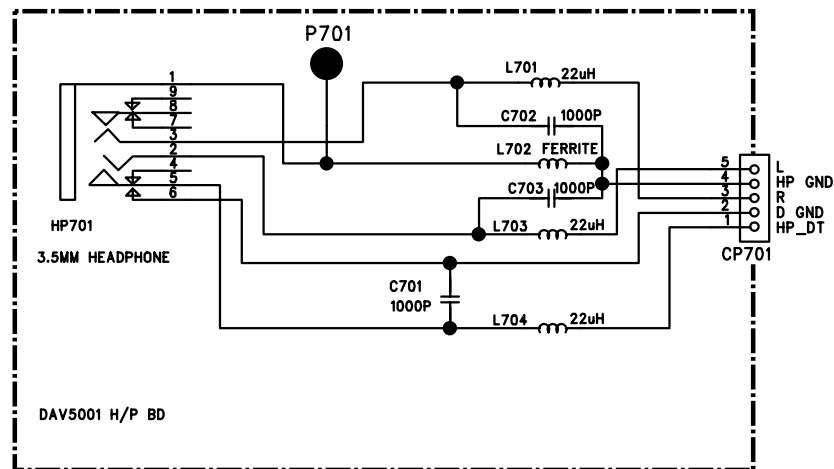

**Headphone-jack P.C.B.
Platine prise-casque
Ltpl. Kopfhörerbuschse
Piastra presa per cuffia
Platina toma auriculares**