

IBBK

DV437SI(RU)
DV438SI(RU)

service manual

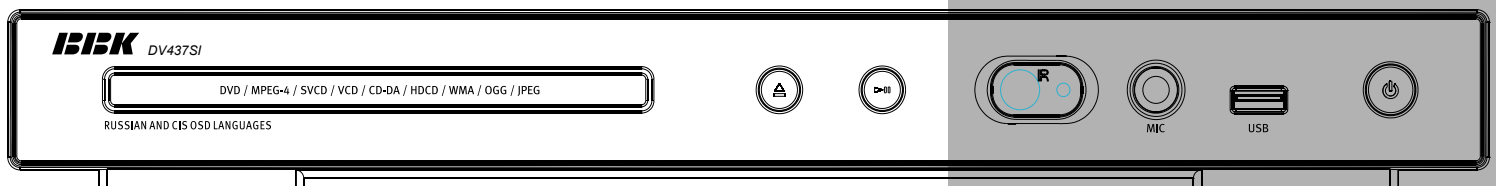

Ver SI10.11

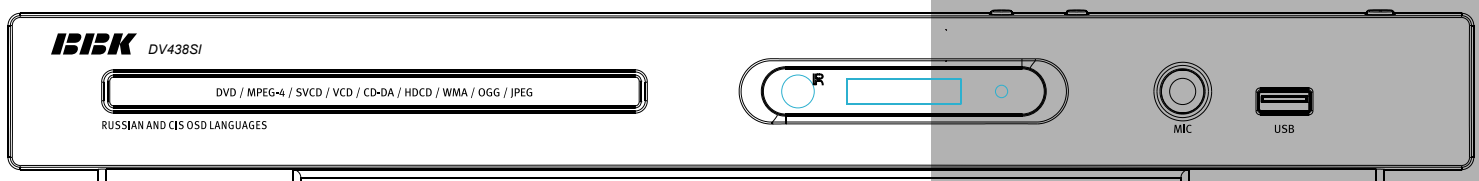

Ver SI10.12

Catalog

Chapter One About Maintenance	1
1.1 Safety precautions	1
1.1.1 Power supply	1
1.1.2 Precautions for antistatic	1
1.1.3 Precautions for laser head	1
1.1.4 A out placement position	2
1.2 Maintenance method	2
1.2.1 Visualized method	2
1.2.2 Electric resistance method	2
1.2.3 Voltage method	2
1.2.4 Current method	2
1.2.5 Cutting method	2
1.2.6 Element substitution method	3
1.2.7 Comparison method	3
1.3 Required device for maintenance	3
Chapter Two Functions and Operation Instructions	4
2.1 Features	4
2.2 Controls and functions	5
2.2.1 Front and side panels control	5
2.2.2 Rear Panel general view	5
2.2.3 LED display general view (NO DISPLAY FOR DV437SI)	6
2.2.4 Remote Control general view	6
2.3 Set list	7
2.4 FUNCTION SETTINGS	7
2.4.1 Function selection and change	7
2.4.2 Language settings	7
2.4.3 Image settings menu	8
2.4.4 Sound settings menu	8
2.4.5 Playback settings	9

2.4.6 Karaoke settings menu	10
2.4.7 Preference settings	10
2.4.8 Parental Control	10
2.4.9 Initial setup menu	10
2.4.10 Reset to defaults	10
2.4.11 Exit setting menu	11
2.4.12 Channel delay set-up	11
2.5 MISCELLANEOUS	13
2.5.1 Useful notes	13
2.5.2 Trouble shooting	13
2.5.3 Specification	14
Chapter Three Block Diagram	15
3.1 OVERALL WIRING DIAGRAM FOR PLAYER	15
3.2 BLOCK DIAGRAM FOR PLAYER	16
Chapter Four Block Diagram of Unit Circuit	17
4.1 Servo Circuit	17
4.2 Decode Circuit	18
4.3 Video Circuit	18
4.4 Audio Circuit	19
4.5 Power Circuit	19
Chapter Five Troubleshooting Flow Chart	20
Chapter Six Waveform Diagram	23
Chapter Seven PCB board	27
7.1 Surface layer of Decode Board	27
7.2 Surface layer of AV Board	28
7.3 Bottom layer of AV Board	28
7.4 Surface layer of Power Board	28
7.5 Bottom layer of Power Board	28
7.6 Surface layer of Main Panel	29
7.7 Bottom layer of Main Panel	29
7.8 USB Board	29

7.9 Surface layer of OK Board	30
8.0 Bottom layer of OK Board	30
Chapter Eight Circuit Diagram	31
8.1 Decode Board	31
8.2 Power Board	34
8.3 Main Panel(DV437SI)	35
8.4 Main Panel(DV438SI)	36
8.5 USB Board	37
Chapter Nine BOM List	38

Caution :

This service manual is only applicable to DV437SI(RU) SI10.11

This service manual is only applicable to DV438SI(RU) SI10.12

Chapter One About Maintenance

1.1 Safety precautions

1.1.1 Power supply

When maintenance personnel are repairing DVD players, he should pay special attention to the power board with 220V AC and 330V DC which will cause hurt and damage to persons!

1.1.2 Precautions for antistatic

Movement and friction will both bring static electricity which causes serious damages to integrated IC. Though static charge is little, when a limited quantity of electric charge is added to large-scale integrated IC, as the capacitance is very small in the meantime, now the integrated IC is very much easy to be struck through by static electricity or the performance will decrease. Thus static electricity prevention is of extraordinary importance. The following are several measures to prevent static electricity:

1. Use a piece of electric conduction metal with the length of about 2 metres to insert into the earth, and Fetch the lead wire from the top of the surplus metal and connect to the required static electricity device. The length and depth of the metal embedded under the earth should be determined according to the wettability of the local soil. For humid places, it may be shorter, and longer and deeper for dry places. If possible, it can be distributed and layed in terms of “#” shape.

2. On operating table-board, the antistatic table cushion should be covered and grounded.

3. All devices and equipments should be placed on the antistatic table cushion and grounded.

4. Maintenance personnel should wear antistatic wrist ring which should be grounded.

5. Places around the operating position should also be covered with electric conduction cushion or Painted with antistatic paint.

1.1.3 Precautions for laser head

1. Do not stare at laser head directly, for laser emission will occur when laser head is working, which will Hurt your eyes!

2. Do not use wiping water or alcohol to clean laser head, and you may use cotton swab.

1.1.4 About placement position

1. Never place DVD player in positions with high temperature and humidity.
2. Avoid placing near high magnetic fields, such as loudspeaker or magnet.
3. Positions for placement should be stable and secure.

1.2 Maintenance method

1.2.1 Visualized method

Directly view whether abnormalities of collision, lack of element, joint welding, shedding welding, rosin joint, copper foil turning up, lead wire disconnection and elements burning up among pins of elements appear. Check power supply of the machine and then use hands to touch the casing of part of elements and check whether they are hot to judge the trouble spot. You should pay more attention when using this method to check in high voltage parts.

1.2.2 Electric resistance method

Set the multimeter in resistance position and test whether the numerical value of resistance of each point in the circuit has difference from the normal value to judge the trouble spot. But in the circuit the tested numerical value of resistance is not accurate, and the tested numerical value of integrated IC's pins can only be used for reference, so the elements should be broken down for test.

1.2.3 Voltage method

Voltage method is relatively convenient, quick and accurate. Set the multimeter in voltage position and test power supply voltage of the player and voltage of a certain point to judge the trouble spot according to the tested voltage variation.

1.2.4 Current method

Set the multimeter in current position and test current of the player of a certain point to judge the trouble spot. But when testing in current method, the multimeter should be series connected in the circuit, which makes this method too trivial and troublesome, so it is less frequently used in reality.

1.2.5 Cutting method

Cutting method should be combined with electric resistance method and voltage method to use. This method is mainly used in phenomena of short circuit and current leakage of the circuit. When cutting the input terminal voltage of a certain level, if voltage of the player rises again, it means that the trouble lies in this level.

1.2.6 Element substitution method

When some elements cannot be judged good or bad, substitution method may be adopted directly.

1.2.7 Comparison method

A same good PC board is usually used to test the correct voltage and waveform. Compared these data with those tested through fault PC board, the cause of troubles may be found.

Through the above maintenance method, theoretical knowledge and maintenance experience, all difficulties and troubles will be readily solved.

1.3 Required device for maintenance

- ◆ Digital oscillograph ($\geq 100\text{MHz}$)
- ◆ TV set
- ◆ SMD rework station
- ◆ Multimeter
- ◆ Soldering iron
- ◆ Pointed-month pincers
- ◆ Cutting nippers
- ◆ Forceps
- ◆ Electric screw driver
- ◆ Terminals connecting cord
- ◆ Headphone
- ◆ Microphone

Chapter Two

Functions and Operation Instructions

2.1 Features

Compatible Disc Types

#Digital video playback: DVD-video, super VCD, VCD compatibility

#MPEG-4 standard support: compatibility with DivX3.11, DivX4, DivX5, DivX Pro, XviD compressed video files

#Digital audio playback: CD(CD-DA)and HDCD compatibility

#Fully compatible with compressed audio files such as MP3,WMA and OGG Vorbis formats

#Playback of DVD-Video, VCD, CD+G Karaoke discs

#Digital graphic albums playback: Kodak picture CD, JPEG compatibility

Audio

#192 kHz/24 bit Audio Digital/Analog converter

#Coaxial and optical outputs for Dolby Digital/DTS/LPCM digital audio

#Mixed audio output for amplifier and TV connection

#Digital multi-channel decoders, providing Dolby Digital/DTS audio stream playing

#Built-in Dolby Pro Logic II decoder makes available to convert stereo signal into multi-channel

#MIC input for karaoke function(only for models DV611SI,DV615SI,DV624SI ,DV626SI,DV628SI)

#Headphones output(only for models DV626SI,DV628SI)

Video

#Progressive Scan Output(Y Pb Pr) producing flicker-free and stable images

#Composite, component(Y Cb Cr), S-Video and RGB/SCART outputs for various types of

Connections

#Capable of playing NTSC/PAL discs written in NTSC system

#Multiple dubbings, angles, subtitles support

#Sharpness,gamma, brightness, contrast, hue, saturation adjustment

Others

#Compatible disc types: CD-R/CD-RW,DVD-R/DVD-RW,DVD+R/DVD+RW

#USB interface to connect Mp3 player, flash card or digital camera

#KARAOKE+ system, expanding karaoke function

#Russia, CIS and Baltic States adaptation interface and filenames, ID3-tags and CD-Text support simplifies device operation

#"Memory" function enables to save the last position after stop playback

#"Q-Play" function provides direct playback and allows to skip commercial impossible to rewind

#"Virtual Keyboard" function provides more convenient DVD playback control

#"Browser" function provides easy access to playback control

#Automatic Screensaver function

#Parental control function to protect children from watching inappropriate discs

#Super wide range of operating power supplies (~110-250v,50/60 Hz), automatic short circuit protection

2.2 Controls and functions

2.2.1 Front and side panels control

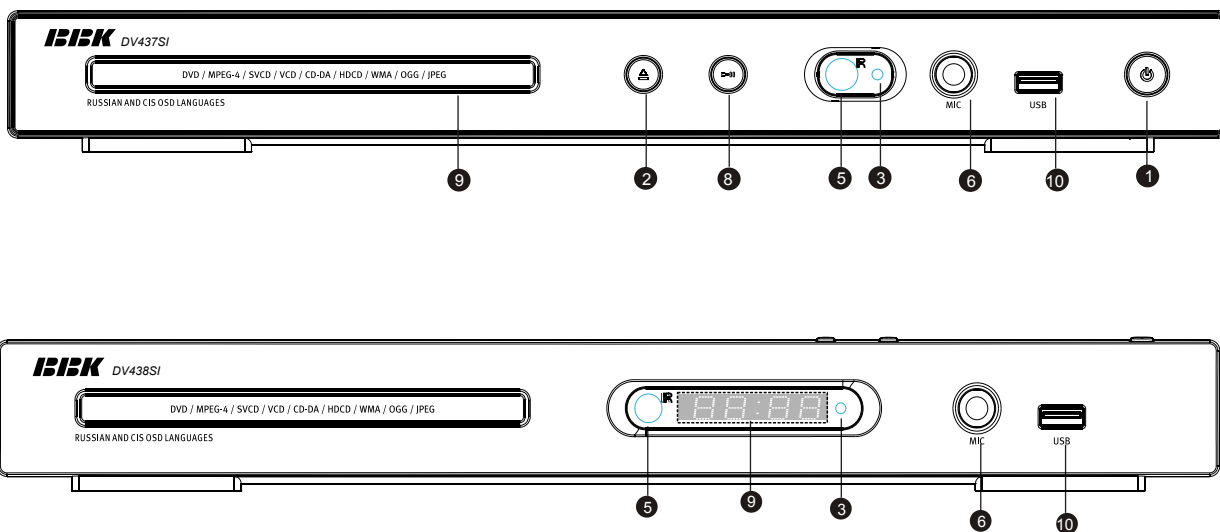

- | | |
|---|---|
| <ul style="list-style-type: none"> ❶ POWER button(Press to switch ON/OFF the device) ❷ OPEN/CLOSE button(Press to open/close the disc tray) ❸ The indicator of operating mode/Standby mode ❹ Sensor of infrared beams | <ul style="list-style-type: none"> ❺ Microphone input ❻ STOP button(Press to stop the playback) ❼ PLAY/PAUSE button(Press to playback/pause) ❽ Disc tray ❾ USB port ❿ Phones jack |
|---|---|

NOTE:

#Presence and location of the buttons, sockets and regulators depend on a model of DVD player.

2.2.2 Rear Panel general view

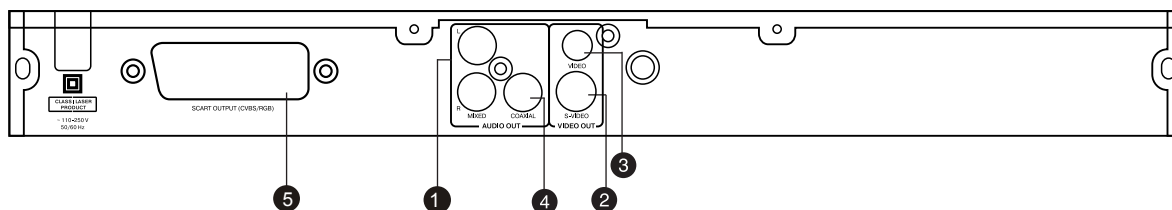

- | | |
|---|--|
| <ul style="list-style-type: none"> ❶ Stereophonic audio output ❷ Socket of video output S-Video ❸ Socket of composite video output | <ul style="list-style-type: none"> ❹ Socket of coaxial digital audio output ❺ SCART socket |
|---|--|

NOTE:

#Presence and location of the buttons, sockets and regulators depend on a model of DVD player.

2.2.3 LED display general view

Playback time

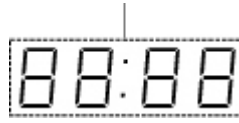

2.2.4 Remote Control general view

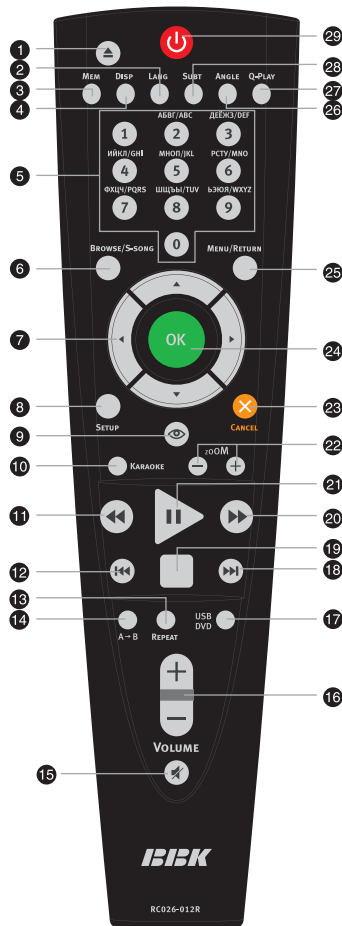

- 1 Button [▲]
Press to open / close the disc tray.
- 2 LANG Button
Press to change the language
- 3 MEM button
Press to memorize the point where playback was stopped/playback from the previously memorized point.
- 4 DISP button
Press to display the disc information.
- 5 NUMERIC buttons
- 6 BROWSE button
Press to turn on/off the browser function
- 7 Cursor buttons (UP/DOWN/LEFT/RIGHT)
- 8 SETUP button
Press to switch to setup mode.
- 9 Button [👁️]
Press to turn on/off the Virtual Keyboard function.
- 10 KARAOKE button
Press to set karaoke function.
- 11 Button [⏮️]
Press to reverse scanning.
- 12 Button [⏪️]
Press to playback from the previous point.
- 13 REPEAT button
Press to repeat playback.
- 14 A-B buttons
Press to repeat the selected portion.
- 15 Button [🔊]
Press to turn on/off the sound.
- 16 VOLUME +/- button
Press to adjust the volume.
- 17 DVD/USB button
Press to switch DVD/USB models.
- 18 Button [⏩️]
Press to playback from the following point.
- 19 Button [⏸️]
Press to stop playback.
- 20 Button [⏭️]
Press to forward scanning.
- 21 Button [▶️]
Press to play/pause the playback.
- 22 ZOOM +/- button
Press to zoom in/out the image.
- 23 CANCEL button
Press to go one level/cancel current operation.
- 24 OK button
- 25 MENU button
DVD-disc menu/PBC function
- 26 ANGLE button
Press to change camera angle
- 27 Q-PLAY button
Press to turn the Q-Play mode on.
- 28 SUBT button
Press to change the subtitles language/JPEG mode.
- 29 Button [🔌]
Press to switch the device on/into standby.

2.3 Set list

DVD player	1PCS
Audio cord	1PCS
Video cord	1PCS
Remote control	1PCS
Battery AAA	2PCS
Warranty card	1PCS
User's manual	1PCS

2.4 FUNCTION SETTINGS

2.4.1 Function selection and change

Press the SETUP key to show the setup menu. You will see the following image on the screen, as shown on the figure:

Select the desired menu item using the UP and DOWN buttons; press OK for confirmation.

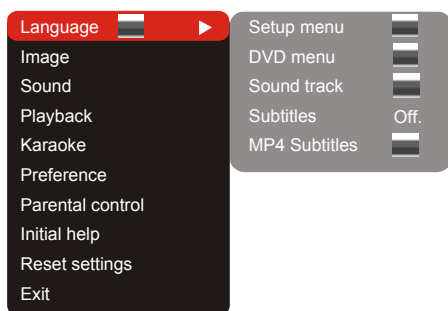

1. For example, if you wish to change the image settings, you have to select the Image item and press the OK.

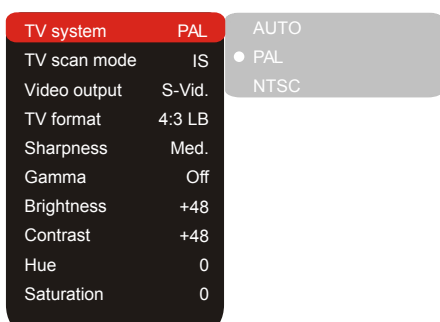

- Using the Up and Down buttons, select the desired item and press OK. For example, select the Sharpness item. Settings will appear on the screen. Then select the desired sharpness level and press OK for confirmation.
- Press LEFT key of the UP and DOWN buttons for exit to previous menu level.
- Press SETUP to exit setup menu.

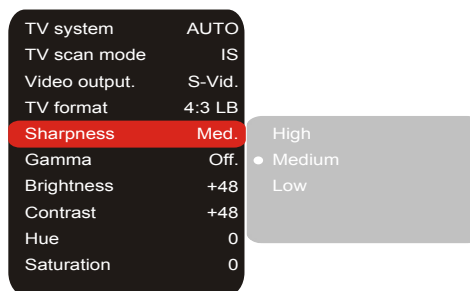

2.4.2 Language settings

1. menu: interface language setup

#Options: Russian, English, Ukrainian, Romanian.

#Default option: English.

2. DVD menu: selection of disc menu language

3. Soundtrack: selection of translation language

#Options: Russian, English, Estonian, Latvian, Kazakh, Romanian, Belarusian, Ukrainian, Chinese.

#Default: English.

#Selection of other languages: select the OTHERS item using the UP and DOWN buttons and press OK. Enter the language code using the numeric buttons and press OK.

#If the language you selected is not recorded on the DVD disc, another available language will be used.

4. DVD Subtitles: selection of DVD subtitles language

#Options: Off, Russian, English, Estonian, Latvian, Kazakh, Romanian, Belarusian, Ukrainian, Chinese and others.

#Default option: Off.

#Selection of other languages: select the OTHERS item using the UP and DOWN buttons and press OK. Enter the language code using numeric buttons and press OK.

#If the language you selected is not recorded on the DVD disc, another available language will be displayed.

5. MP4 subtitles: selection of Mp4 subtitles language

#Options: Russian, English, Ukrainian, Romanian.

#Default option: English.

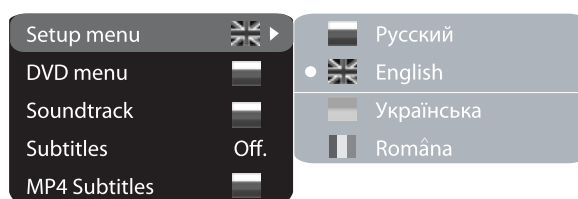

2.4.3 Image settings menu

1. TV system: TV system selection
#Options: Auto, PAL, NTSC.
#Default option: PAL.
2. TV scan mode: scan mode Selection
#Options: progressive, interlaced.
Default option: Interlaced .
#Progressive scan is transferred only via a component video output.
#Before switching to progressive scan, make sure that your TV set supports this operation mode.
3. Video output: selection of video signal
#Options: S-Video, Comp, SCART.
#Default option: S-Video.
4. TV Format: image ratio settings
#Options 4:3 Pan&scan, 4:3 letterbox and 16:9 TV.
#Default option: 4:3 letterbox.
#Some discs are recorded with support of only one ratio. The selected ratio must comply with the TV screen.
5. Sharpness: image sharpness adjustment
#Options: High, Medium, Low.
#Default option: Medium.

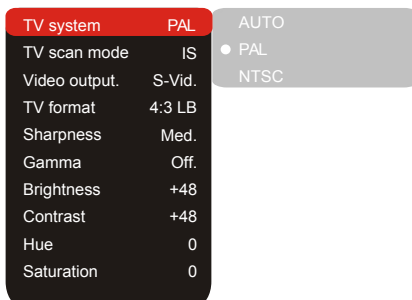

6. Gamma :adjustment of image color temperature
#Options: High, Medium, Low, Off.
#Default option: Off.
 7. Brightness: adjustment of image brightness
 8. Contrast: adjustment of image contrast.
 9. Hues: adjustment of image hues.
 10. Saturation: adjustment of image saturation
- Adjustment of image brightness, contrast, hues and saturation:
#Select the desired item of the image adjustment section using the Up and Down buttons. Press OK or RIGHT key to start adjusting the relevant option.
#Change the option value using the Up and Down buttons.

#Upon completion press the LEFT key of the UP and DOWN buttons to return to image setup menu.

2.4.4 Sound settings menu

1. Mixer

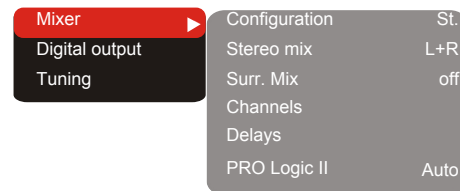

A). Configuration: setting of the mode for stereo signal

#Options : Stereo

#Default option: Stereo.

B). Stereo mix: playback set-up while playing the disc with two independent audio channels.

#Options : L+R, L, R.

#Default options: L+R.

C). Surr. Mix: set-up of surround options while playing the Stereo disc.

#Options : Off, Virt. Surr.

#Default options: Off.

D. Low band: distribution of low frequencies through channels.

#Default options: Front F

#If you want the low-frequency component of the sound signal enter only the subwoofer channel, select and confirm the parameter Subwoofer SW.

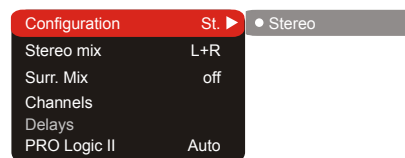

E. Channel settings: separate adjusting of volume by channels.

G. PRO Logic II: function of stereo sound conversion to 5-channel sound.

#Options: On, Off, Auto.

#Default option: Auto.

#In Auto position, the DVD player determines itself, when to use the PRO Logic II decoder. Some discs do not support this function.

2. Digital audio output

A. SPDIF format: set-up of digital audio output options

#Options: RAW , PCM.

#Default options: RAW.

#When you select the RAW option, the undecoded signal is transferred to the DVD player's digital outputs, the decoded signal is transferred to analog outputs. Decoding is performed by the built-in decoder of the DVD player. This feature is meant to ensure that signal decoding at digital outputs is performed by an external device(e.g.an amplifier)

#If you select the PCM option, a PCM coded signal will be transferred to the DVD player's digital outputs.

B. LPCM: set-up of digital audio output options to comply with different amplifiers and receivers.

#Options: 48 kHz 16 bit, 96 kHz 24 bit

#Default option: 48 kHz 16 bit.

3. Sound correction:

A. Max volume: max volume limiting.

#Using the Up and Down buttons, adjust the max volume level.

#Press the LEFT key of the Up and Down buttons to return to sound correction setup menu.

B. Equalizer: equalizer modes.

#Options: Rock, Pop, Live, Dance, Techno, Classic, Soft.

#Default option: Off.

C. Echo: echo effects.

#Options: Off, Concert, Living room, Hall, Bathroom, Cave, Arena, Church.

#Default option: Off.

D. Tone balance: adjustment of tone balance level.

#Adjust the tone balance level using the Up and Down buttons.

#Press the LEFT key of the Up and Down buttons to return to sound correction setup menu.

2.4.5 Playback settings

1. DVD: Advertisement skip: skip the unskippable block while playing a DVD disc.

#Options: Yes, No.

#Default option: No.

2.VCD/SVCD: PBC menu :PBC menu on/off

#Options: On, Off.

#Default option: On.

#If On option is set, while reproducing discs, a menu will appear, in which you can select the order of playing the disc content. If the Off option is set, the reproducing of content is performed in the order, in which it is recorded on the disc.

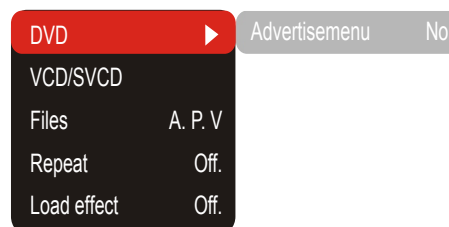

NOTE:

#This function is possible with no disc loaded.

3. Files: selection of reproduced files on the disc
 #Options: Audio, Picture, Video.

#Default option: A, P, V

4. Repeat : file repeat mode

#Options: Off, Single, All.

#Default option: Off.

5. Load effect: type of transition from one JPEG file to another

#Options: Off, from top, from bottom

#Default option: Off.

2.4.6 Karaoke settings menu

1. Microphone: Microphone on/off

#Options: On, Off.

#Default option: Off.

2. Kar. help: karaoke disc playback mode

#Options: L Channel , R Channel , No ast , No voc.

#Default option: No ast .

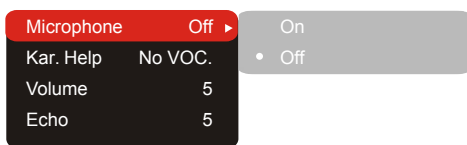

3. Volume:

Microphone: microphone sound volume level.

#Using the UP/DOWN buttons adjust the microphone volume level.

#Press LEFT key of the UP/DOWN buttons to return to karaoke settings menu.



4. Echo: echo level while playing the karaoke disc

#Adjust the echo level Using the UP/DOWN buttons.

#Press LEFT key of the UP/DOWN buttons to return to karaoke settings menu.

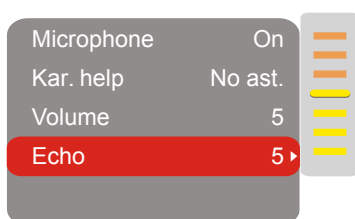

2.4.7 Preference settings

1. Gr. Equalizer: spectrum analyzer

#Options: On, Off.

#Default option: Off.

3. Screensaver: screen saver on/off

#Options: On, off.

#Default option: On.

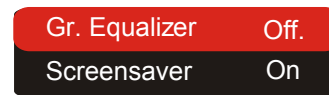

2.4.8 Parental Control

1. Category: setup of age restrictions to prevent children from seeing undesirable discs.

#Options: Any, Kid, G, PG, PG-13, PGR, R, NC-17.

#Default option: Any.

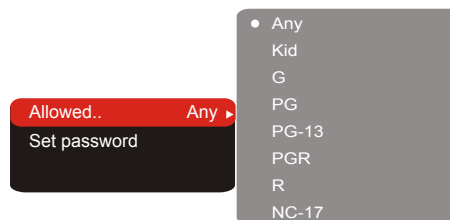

2. Set password: setup of a four-digit password to change the level of age restrictions.

#Default option: 7890.

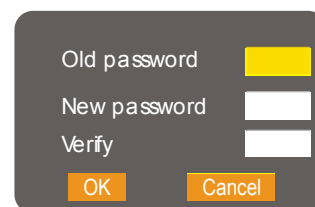

2.4.9 Initial setup menu

#Press the RIGHT key of the UP/DOWN buttons to enter the initial setup menu, then select the desired item using the buttons Up and Down and press OK key for confirmation.

#While being in this menu section, you cannot return to the previous level by pressing the LEFT key of the UP/DOWN buttons.

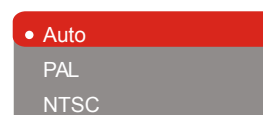

2.4.10 Reset to default ts

Resetting all settings and restoring default options, except age restrictions level and password.

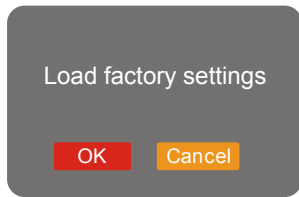

2.4.11 Exit setting menu

Select the exit item using the Up and Down buttons and press the OK to exit the menu.

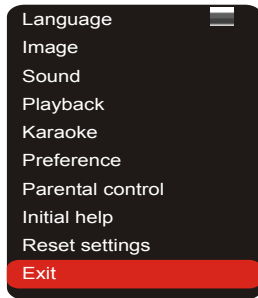

2.4.12 Channel delay set-up

Set-up of time delay in the surround channel

Usually, time delay in the Dolby Digital decoding system is preset to ensure best effect while installing the Home Theater. However, in case you wish to adjust your system more precisely, please consult instructions given in this manual. Set up of time delay for this device is possible in both Dolby Digital and Dolby Pro Logic modes..

To Set the desired delay you have to know the distance from the place where you are, to the front speakers and Surround speakers as shown in Fig. 1 Consult Fig.2(Dolby Pro Logic mode) and3(Dolby Digital mode) in order to determine the distance to Surround speakers(axis Y in the figure) and the distance to the front speakers (axis in the figure).Crossing point of those two lines on the chart will give the recommended delay value.

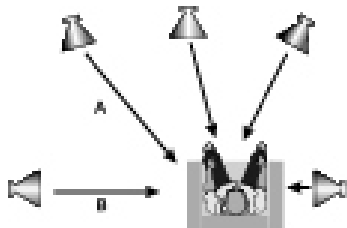

Fig.1.Take into account the A-B distance; use both figures for setting the desired time delay.

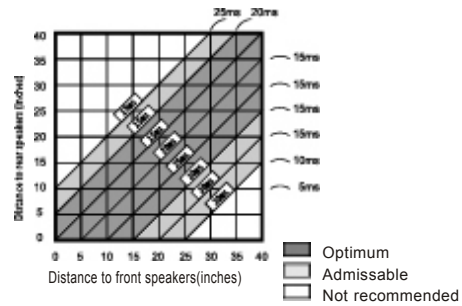

Fig.2.Determine delay value as to Dolby Pro Logic mode

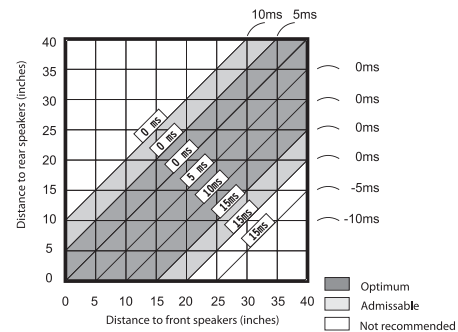

Fig.3.Determine delay value as to Dolby Digital mode.

Set-up of time delay in the central channel

Sometimes several people are listening to the music, and the space is limited. In this case, you can install three speakers(two front ones and a central one) as shown in Fig.1 with the distance to the listener being approximately the same. The central channel delay is to be set at "0".

Should the central speaker be in close proximity to left and right front speakers as shown in Fig. 2, or the central speaker be nearer to listeners when compared with front speakers' location, or the central speaker be nearer to the listener by 1 foot, in all these cases you may set the delay value for the central channel at 1 ms.

For instance, as shown in Fig.2, if the line C is by 1 foot shorter than the lines R and L, the delay value is to be set at 1 ms. If your sofa is broad enough, and there are several listeners sitting on it, it makes sense to locate the speakers in one line, as shown in Fig.3 with the delay value of the central to be set at "0".

Finally, if it will be necessary to install the central speaker behind the left and right front speakers, the delay value shall be set at "0".



Fig.1.Delay of central channel=0
L=C=R

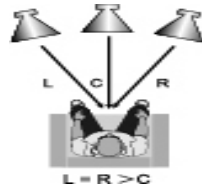

Fig.2.Small area Delay of central channel=L=(or) L=R>C

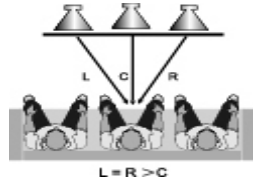
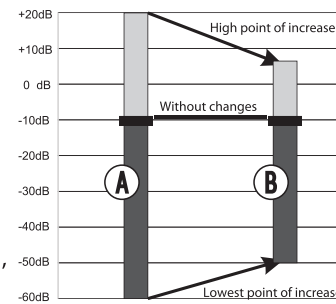

Fig.3.Small area Delay of central channel=0
L=R>C



“Night” mode

The Dolby Digital system provides an extremely broad dynamic range of playback sound-from gentle to roaring. It creates the presence effect, especially while seeing motion pictures. However, at night a powerful sound with a broad dynamic range may give pleasure to you ,but disturb and annoy your family and neighbors. If you just decrease the volume, you will immediately notice that you ceased to hear, e, g, dialogues as clear as you do at normal volume, and such sound effects as rustle,

whisper etc. have merely disappeared. To avoid this, you just have to decrease the volume of “loud” sounds by simultaneously increasing the volume of “soft” sounds with the volume of “average” sounds left unchanged, i.e. Just decrease the dynamic range of sound accompaniment. Only Dolby Digital system provides for such a method of sound control. It uses the principle of compressing the acoustic signal’s dynamic range while recording; therefore, while playing an inverse transformation(volume expansion) takes place. This is called”night” mode. The regulation limits are restricted, however, to avoid distortions of resultant signal.

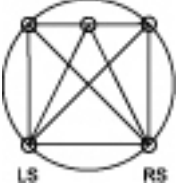

Principle of compressing the acoustic signal’s dynamic range.

	Dolby Digital	Dolby Pro Logic surround
Rear channel	Stereo 20 Hz-20 kHz	Mono channel with limited frequency range(100Hz-7 kHz)
Low-frequency channel(subwoofer)	Available,20-120 Hz	N/a
Sound field distribution	Multivariate 	From left to right, from right to left, from front to rear, from rear to front 
Channels	6 independent channels, each reproducing its own signal at a time	4 segmented channels. Only one channel is decoded at a time.
Miscellaneous	Creates an optimum sound field with illusion of an equal distance from listener to each speaker.	The most cost-efficient way to ensure high-quality surround effect.
	Allows adjusting the decompression degree of sound information("night" mode).	Surround sound may be received from any signal source.

Miscellaneous	Possibility of programmable control of the decoder to transfer basses into low-frequency channel in systems equipped with broad-band speakers and a subwoofer.	Compatible with existing and future two-channel(stereo) formats.
	Undoubted progress in sound recording technology, especially important for program directors, film directors, sound engineers and actors.	Big progress in comparison with conventional stereo, the world's most popular surround format.

2.5 MISCELLANEOUS

2.5.1 Useful notes

#To extend the service life of your DVD player make pauses of not less than 30 seconds between switching off and repeatedly switching on the DVD player.

#Disconnect the DVD player from the wall outlet after shutdown.

#Some DVD player's functions may not be applied to some discs.

#Use supply sources of rated voltage, otherwise the DVD player may not function or be damaged.

#In case of the DVD player's occasional stops, please switch the power supply off and then on again.

2.5.2 Trouble shooting

Please check probable causes of malfunction before addressing the service center.

Sign of trouble	Cause of trouble	Actions to eliminate the trouble
No sound	1.Poor audio cable connection 2.Disc dirty or damaged. 3. Sound disabled by the MUTE button.	1.Make proper connection 2. Clean the disc 3. Press the MUTE button.
No image	1.Poor video cable connection. 2. Incorrect settings of your TV set. 3.The DVD player is in the progressive scan mode while your TV set does not support this mode.	1. Make proper connection. 2. Correct the setting of your TV set. 3. Place the DVD players in the interlaced scan mode through the DVD-receiver's menu.
Black and white image	1. Incorrect TV color system selected. 2. Color level on theTV set adjusted incorrectly.	1. Set the appropriate color system via the menu: SET UP>Image>TV scan. 2.Readjust the color system of your TV set
Discs cannot be read	1. Disc not inserted. 2.Disc inserted incorrectly. 3.Condensate on the DVD player's laser head.	1.Insert the disc. 2.Install the disc with the label side facing up. 3.Switch the DVD players on without disc for an hour.
Microphone does not operate	1.Microphone is unplugged. 2.Low level of the microphone's sound volume.	1.Connect the microphone. 2.Adjust the level of the microphone's sound volume.

Remote control does not operate	1.Remote control is incorrectly directed at the DVD players's screen. 2. Distance to the DVD players is in excess of 8 meters. 3.Run out batteries.	1.Use the remote control according to the manual. 2.Decrease the distance to the DVD players. 3.Replace both batteries.
Some functions do not work	1.Disc is recorded incorrectly. 2.Incorrect key sequence. 3.Static voltage on the DVD player's housing.	1.Wait 5-10 seconds and the DVD players will automatically return to normal state. 2.Repeat the operation one more time. 3.Switch the DVD players off for 1-2 minutes and then switch it on again.
Unstable image	1.Incorrect TV set settings.	1.Correct the TV set settings.

2.5.3 Specification

Supported formats	DVD-Video, Super VCD, VCD, MPEG-4, CD-DA, CD+G, HDCD, MP3, WMA, Kodak Picture CD, JPEG	
Data medium	CD-R, CD-RW, DVD-R, DVD+R, DVD-RW, DVD+RW	
Inputs	Microphone input(two microphone inputs for(DV611SI,DV624SI,DV626SI, DV628SI models.one microphone inputs for DV214&216SI&DV118SI)	
Outputs	Audio outputs	Analog outputs: 2.0CH output. Digital outputs: Coaxial audio out
	Video outputs:	S-Video output, RGB/SCART output, Composite output
Video characteristics	Signal swing of composite video output:	1.0Vp-p(75 Ω)
	Signal swing of S-Video output:	1.0Vp-p(75 Ω)
	Signal swing of component video output:	C:0.286Vp-p(75 Ω) 1.0Vp-p(75 Ω) Cb/Cr:0.7Vp-p(75 Ω)
Audio characteristics	Frequency:	20-20000 Hz(±1 db)
	Signal-to-noise ration:	> 100 db
Voltage range	~110-250V, 50/60 Hz	
Temperature requirement	5-35°C	
Moisture requirement	15-75%(not condensate)	

Model	Dimensions(mm)	Weight(kg)	Power consumption(watt)
DV437SI	360×195×38	1.7	14
DV438SI	360×195×38	1.7	14

#We improve quality of our production permanently, that's why specification can change without notification.

#Some discs, recorded in any supported format on any compatible device, can't playback or can playback incorrect over peculiarity of their record.

Chapter Three Block Diagram

3.1 OVERALL WIRING DIAGRAM FOR PLAYER

Overall wiring diagram of player is shown in figure 3.1.1.

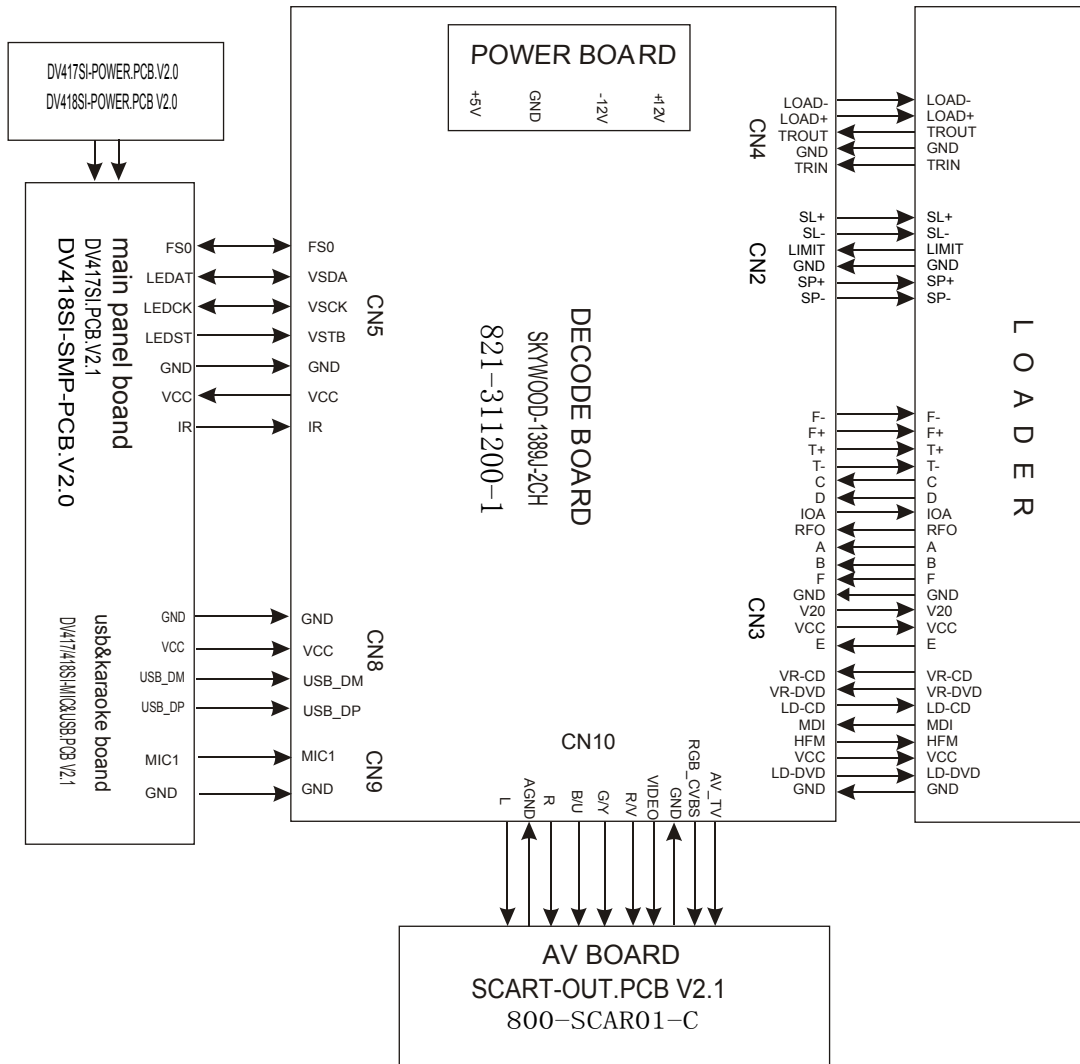

3.2 BLOCK DIAGRAM FOR PLAYER

Block diagram for player is shown in figure 3.2.1.

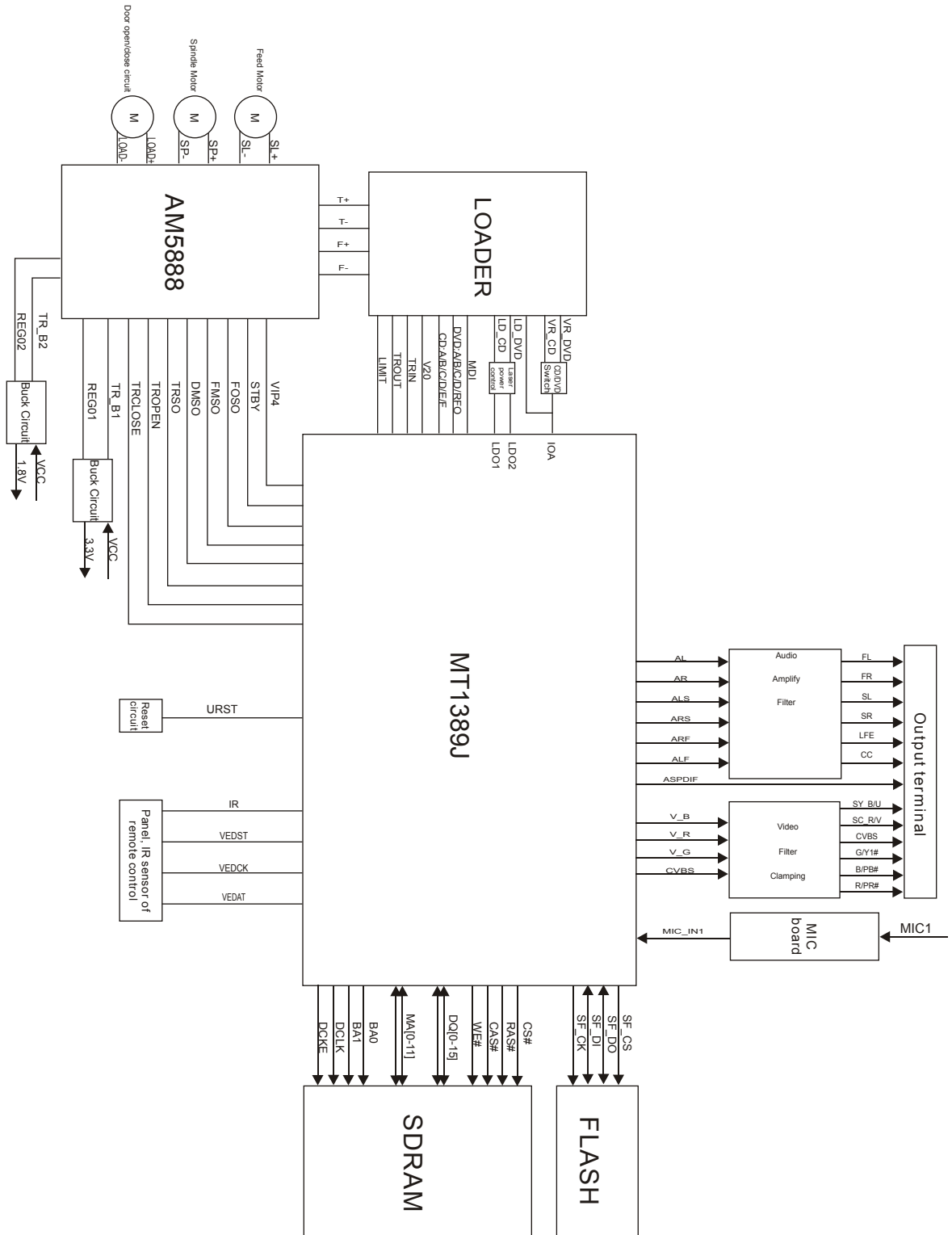

Chapter Four

Block Diagram of Unit Circuit

4.1 Servo Circuit

Servo system of this machine adopts SANYO loader and MTK decode scheme. And servo circuit is mainly composed of front signal processing, digital servo processing, digital signal processing chip MT1389 and driving chip AM5888. MT1389 is also main part of decode circuit. Block diagram of servo circuit is shown in figure 4.1.1.

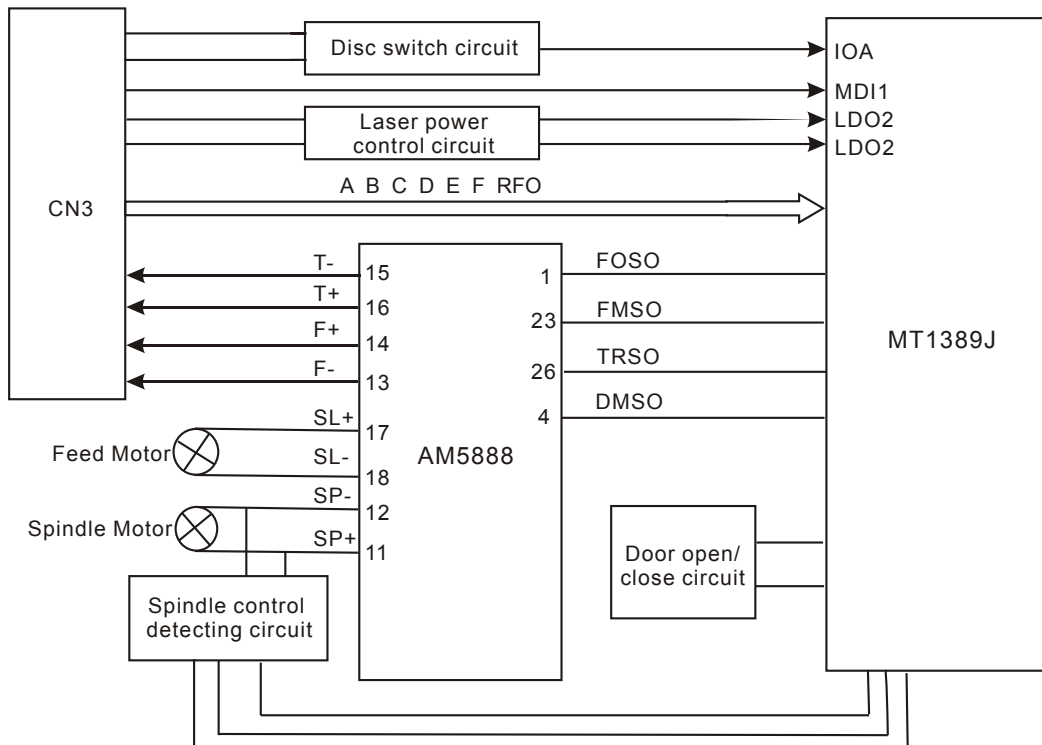

Figure 4.1.1 Block diagram of servo circuit

4.2 Decode Circuit

Decode circuit is mainly composed of MT1389, SDRAM and FLASH. Block diagram of circuit is shown in figure 4.2.1.

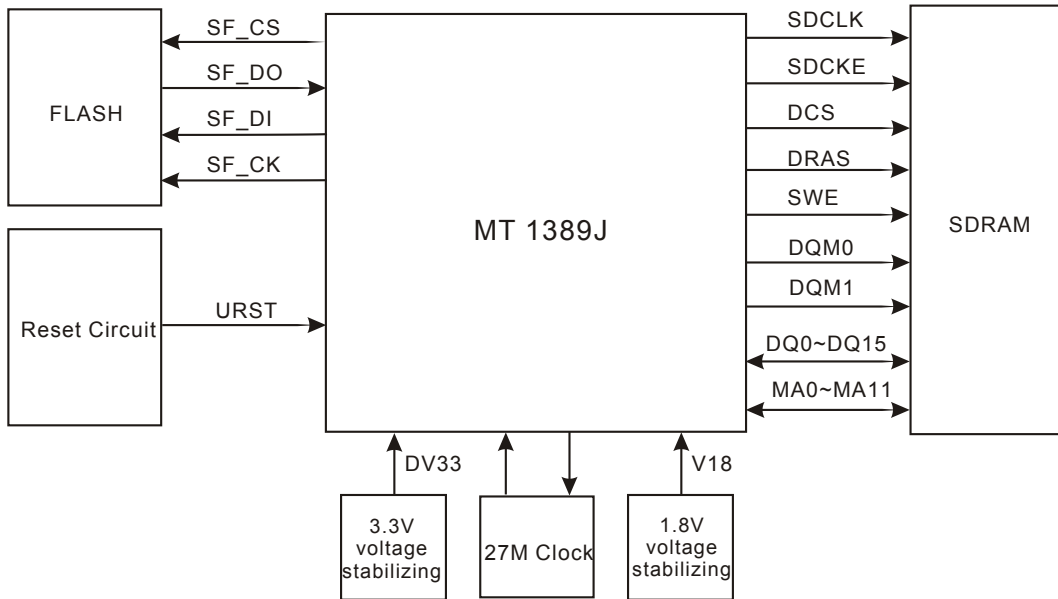

Figure 4.2.1 Block diagram of decode circuit

4.3 Video Circuit

MT1389J has video D/A converter circuit and video output has R/B/G, Y/Pb/Pr, Y/Cb/Cr, CVBS and Y/C output modes, in which R/B/G, Y/Pb/Pr, Y/Cb/Cr and Y/C can not output at the same time and need to be switched via software. CVBS is a separate output mode; four channel video signal is outputted to AV board by MT1389 after video filtering and clamping. Block diagram of video signal process is shown in figure 4.3.1.

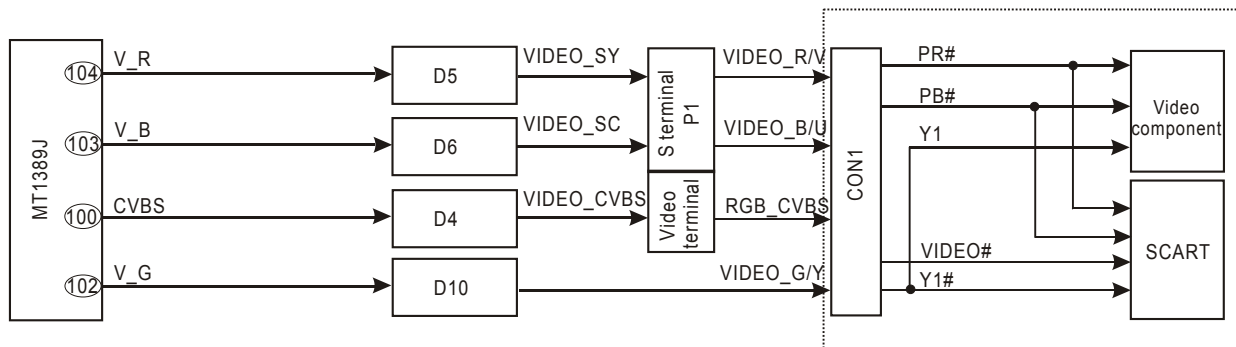

Figure 4.3.1 Block diagram of video signal process

4.4 Audio Circuit

Block diagram for audio circuit is shown in figure 4.4.1:

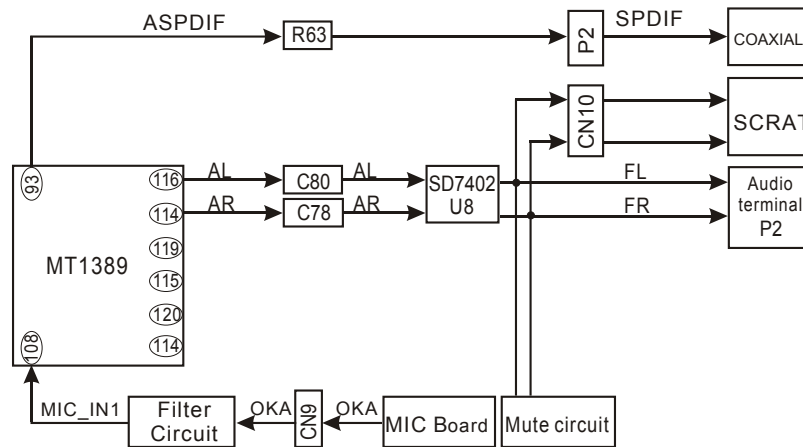

Figure 4.4.1 Block diagram of audio circuit

4.5 Power Circuit

1. Block diagram of power circuit is shown in figure 4.5.1.

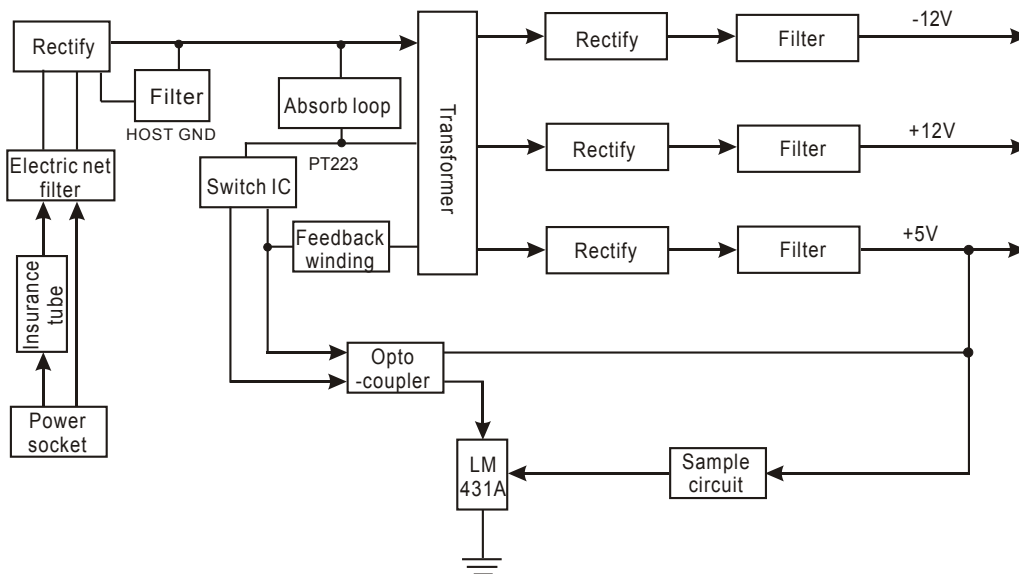
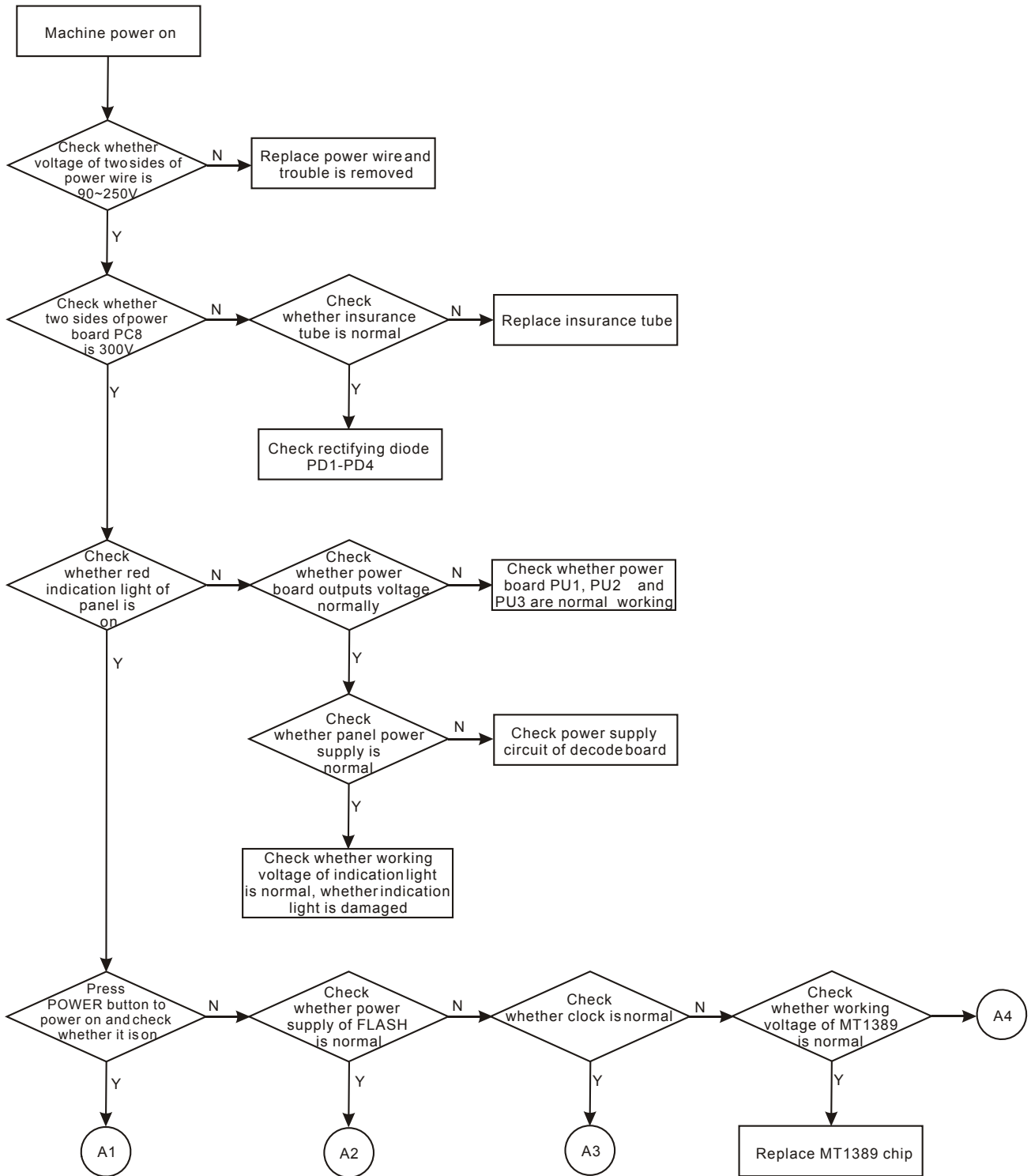
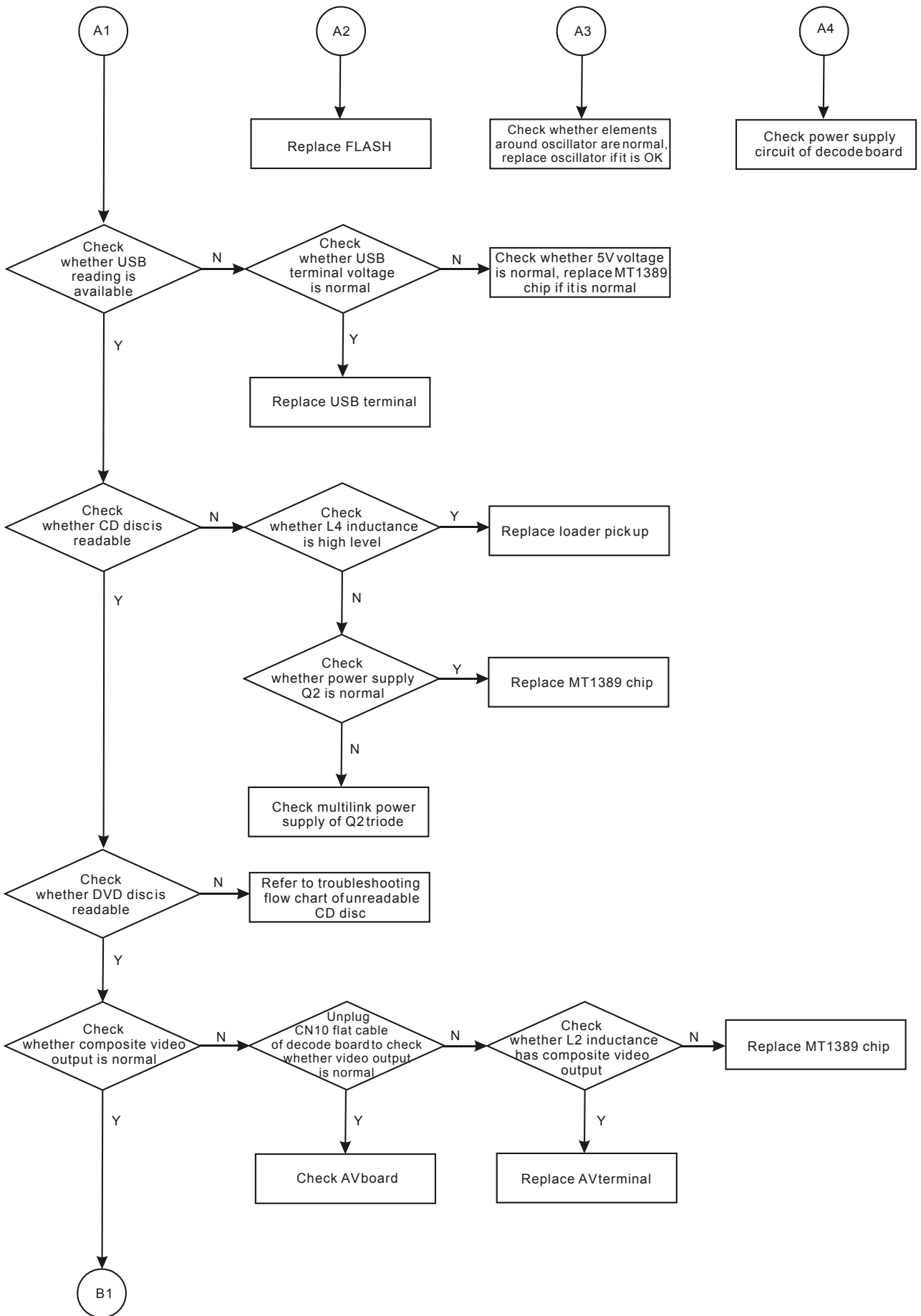

Figure 4.5.1 Block diagram of power circuit

Chapter Five Troubleshooting Flow Chart







Chapter Six Waveform Diagram

This section collects signal waveform diagram of audio, video and each unit circuit with the purpose to help servicing personnel to judge where trouble lies in accurately and quickly to improve servicing skills. For the difference of oscillograph's type, model and tuner, a certain difference may exist, so the servicing personnel are expected to pay more attention to check in daily operation.

1. Waveform diagram for pulse DC of power board PD5 anode.

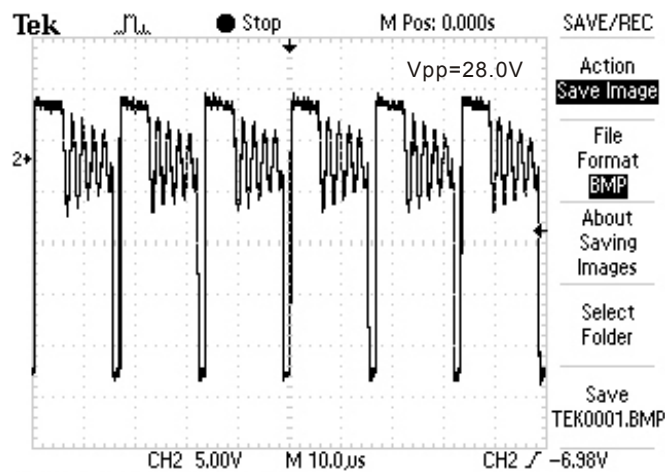

2. Waveform diagram for spindle signal DMO(when spindle has motion).

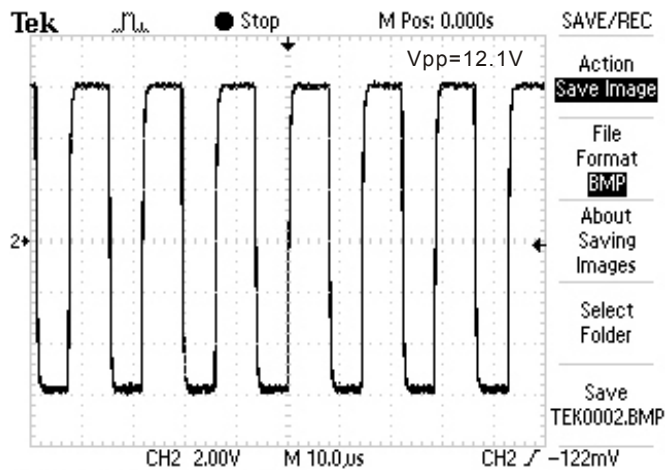

3. Waveform diagram for feed signal FMO(when pick up has feed motion).

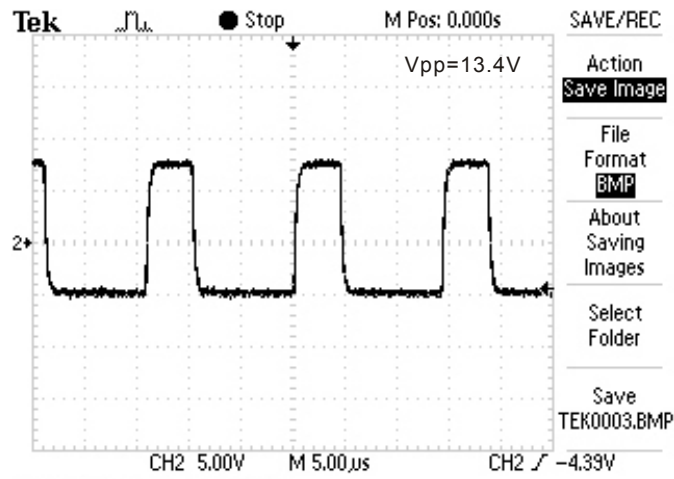

4. Waveform diagram for traction signal TRO(when pick up has traction motion).

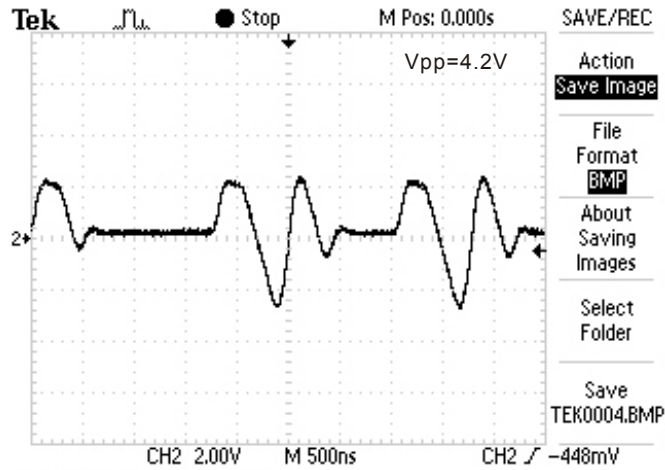

5. Waveform diagram for focus signal FOO(when pick up has focus motion).

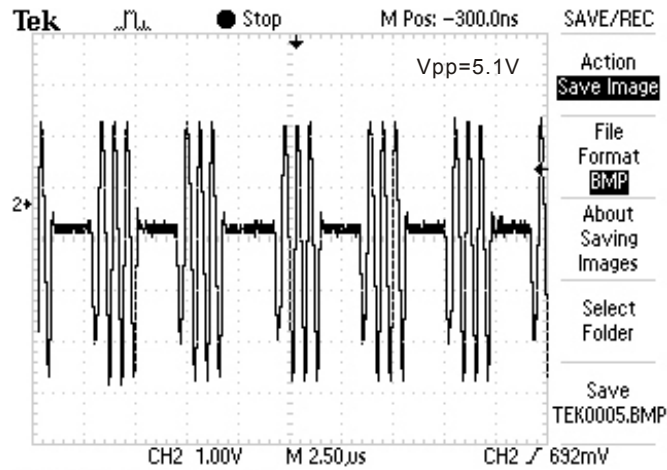

6. Waveform diagram for FLASH chip SF_DI(pin 5 of U6).

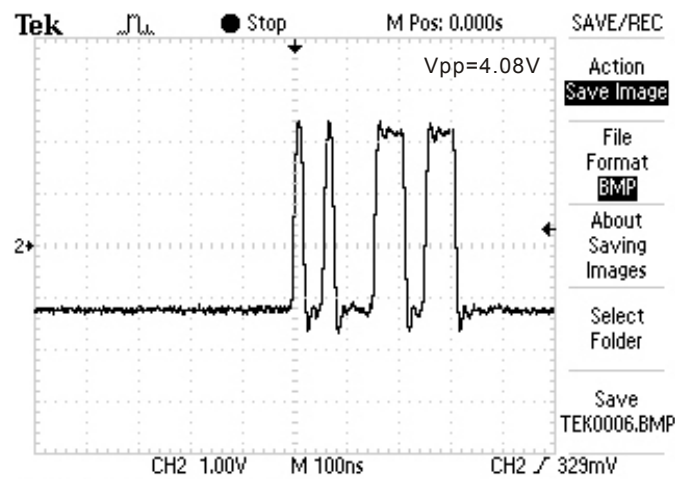

7. Waveform diagram for FLASH chip SF_CK(pin 6 of U6).

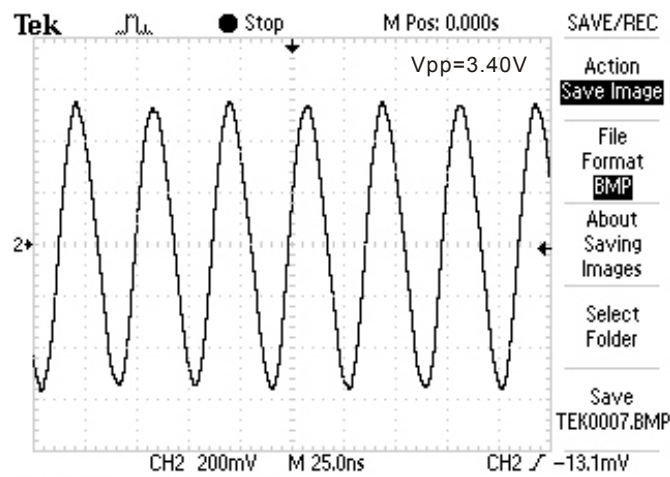

8. Waveform diagram for 27MHz clock (Y1).

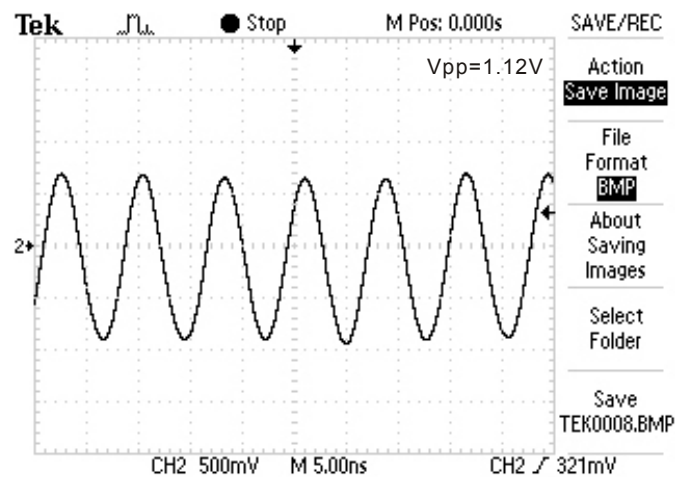

9. Reset signal URST waveform diagram.

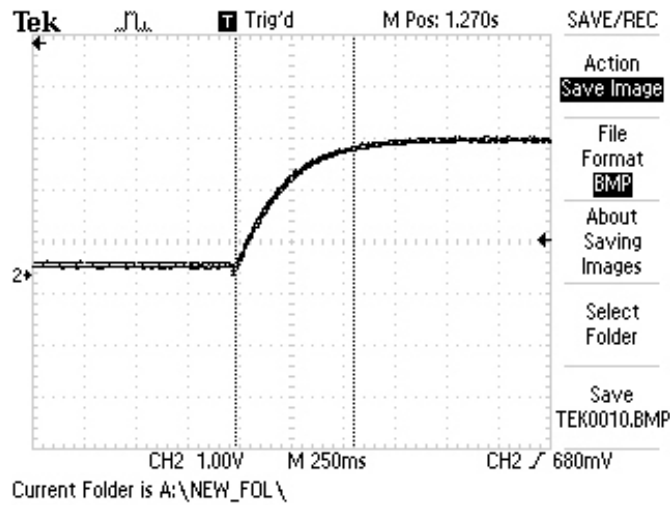

10. Video signal waveform diagram.

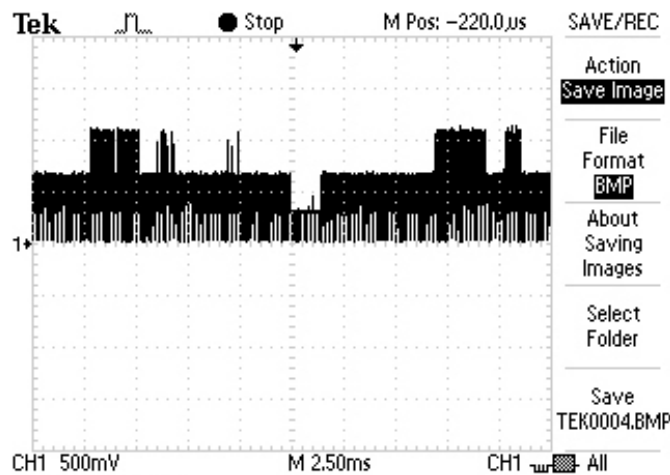

11. 1KHZ audio signal output waveform diagram(it is suggested to use test disc,if not,waveform tested will change at any time,which will affect your judgment).

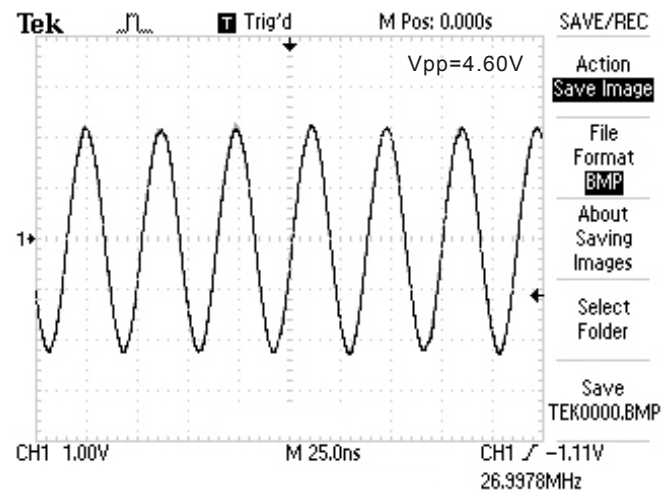

Chapter Seven PCB Board

7.1 Surface layer of Decode Board

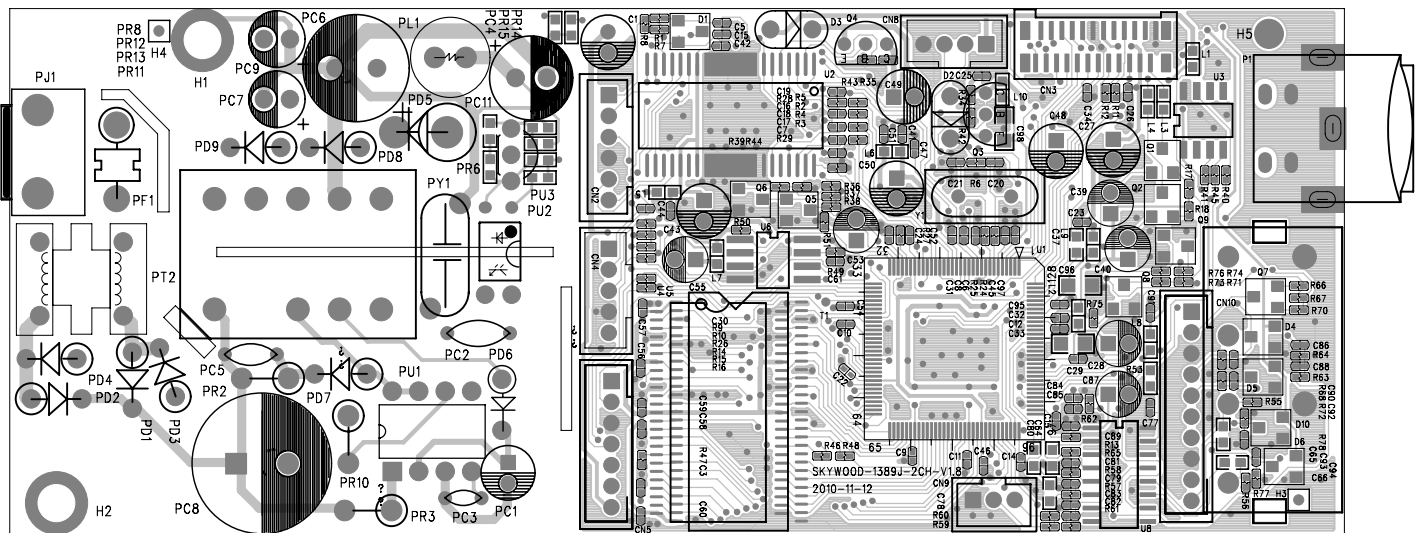

7.2 Surface layer of AV Board

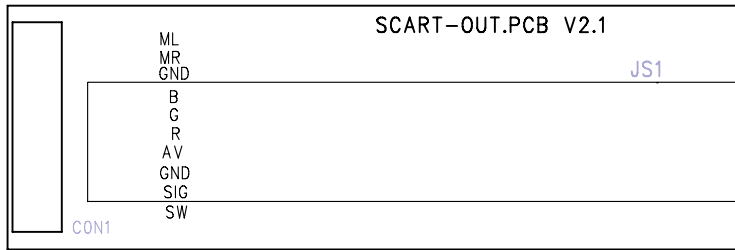

7.3 Bottom layer of AV Board

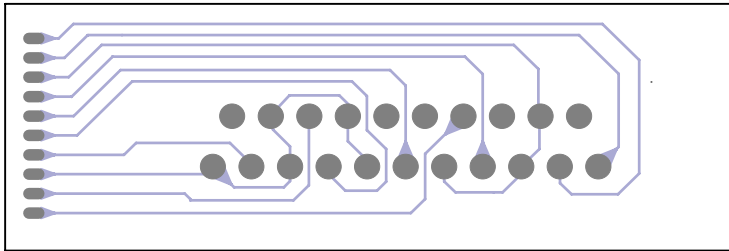

7.4 Surface layer of Power Board

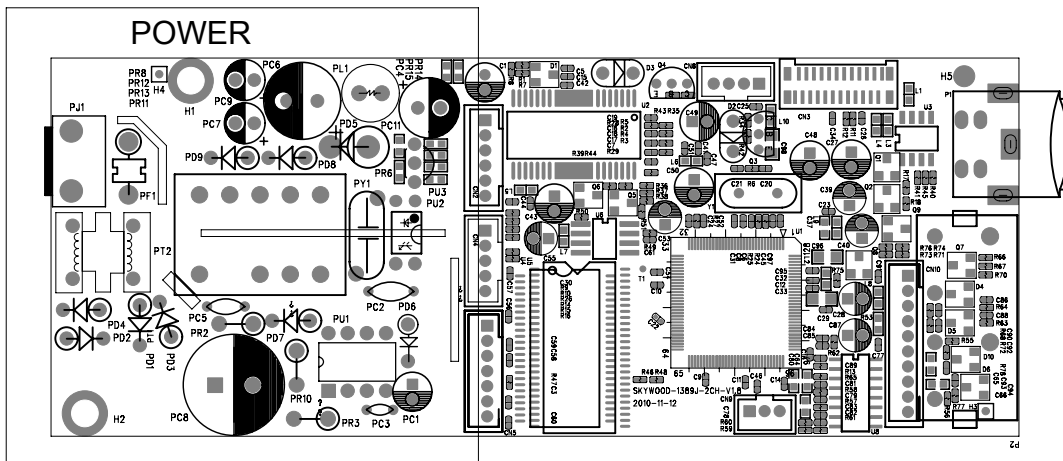

7.5 Bottom layer of Power Board

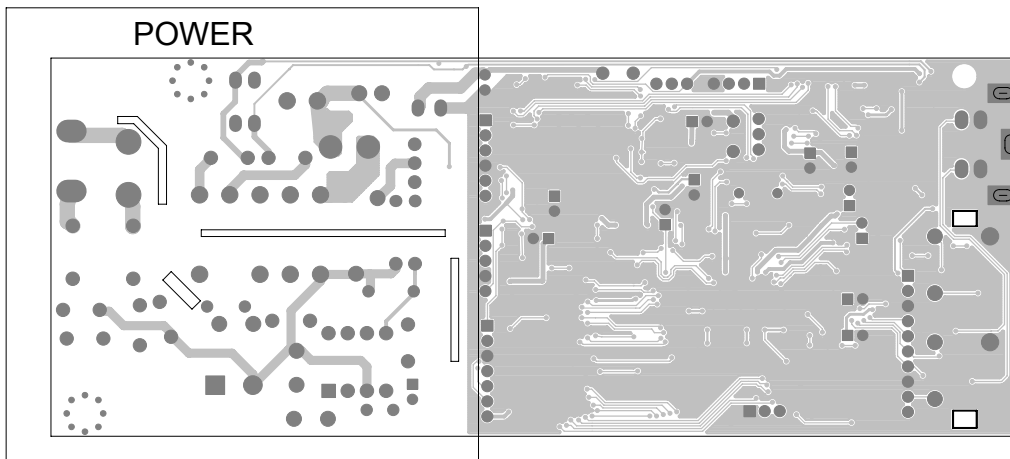

7.6 Surface layer of Main Panel

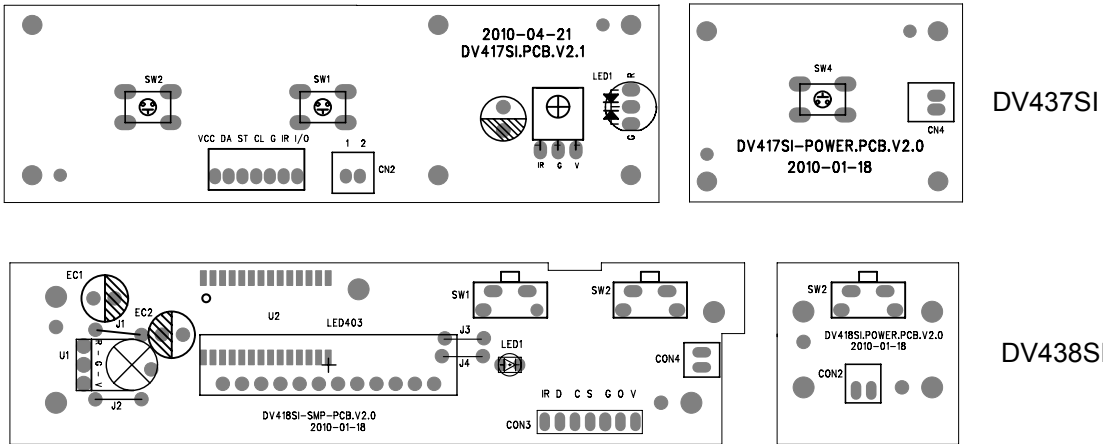

7.7 Bottom layer of Main Panel

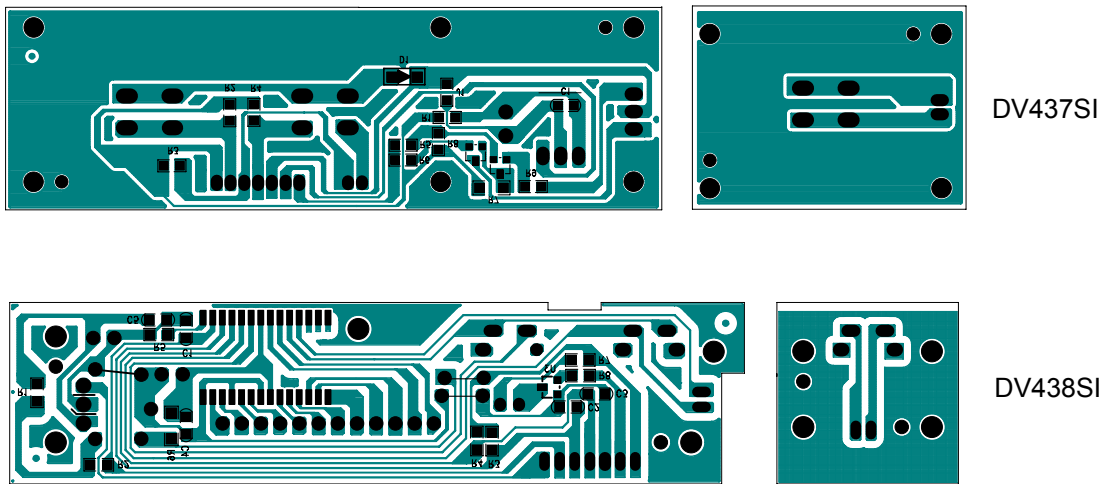

7.8 USB Board

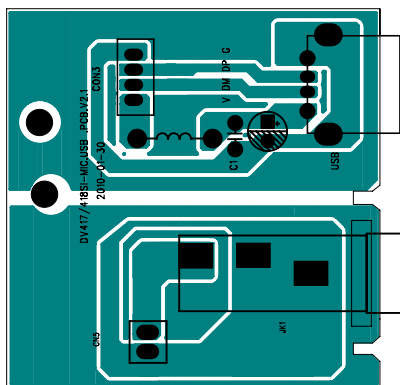

7.9 Surface layer of OK Board

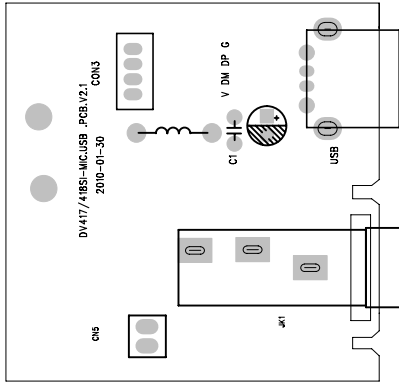

8.0 Bottom layer of OK Board

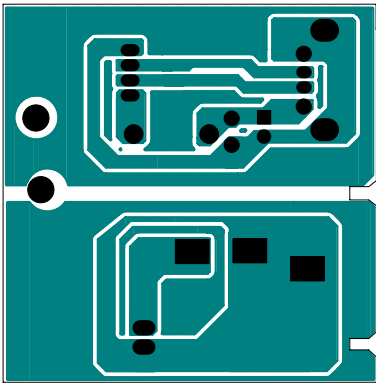

Chapter Eight Circuit Diagram

8.1 Decode Board

OFF-PAGE CONNECTION

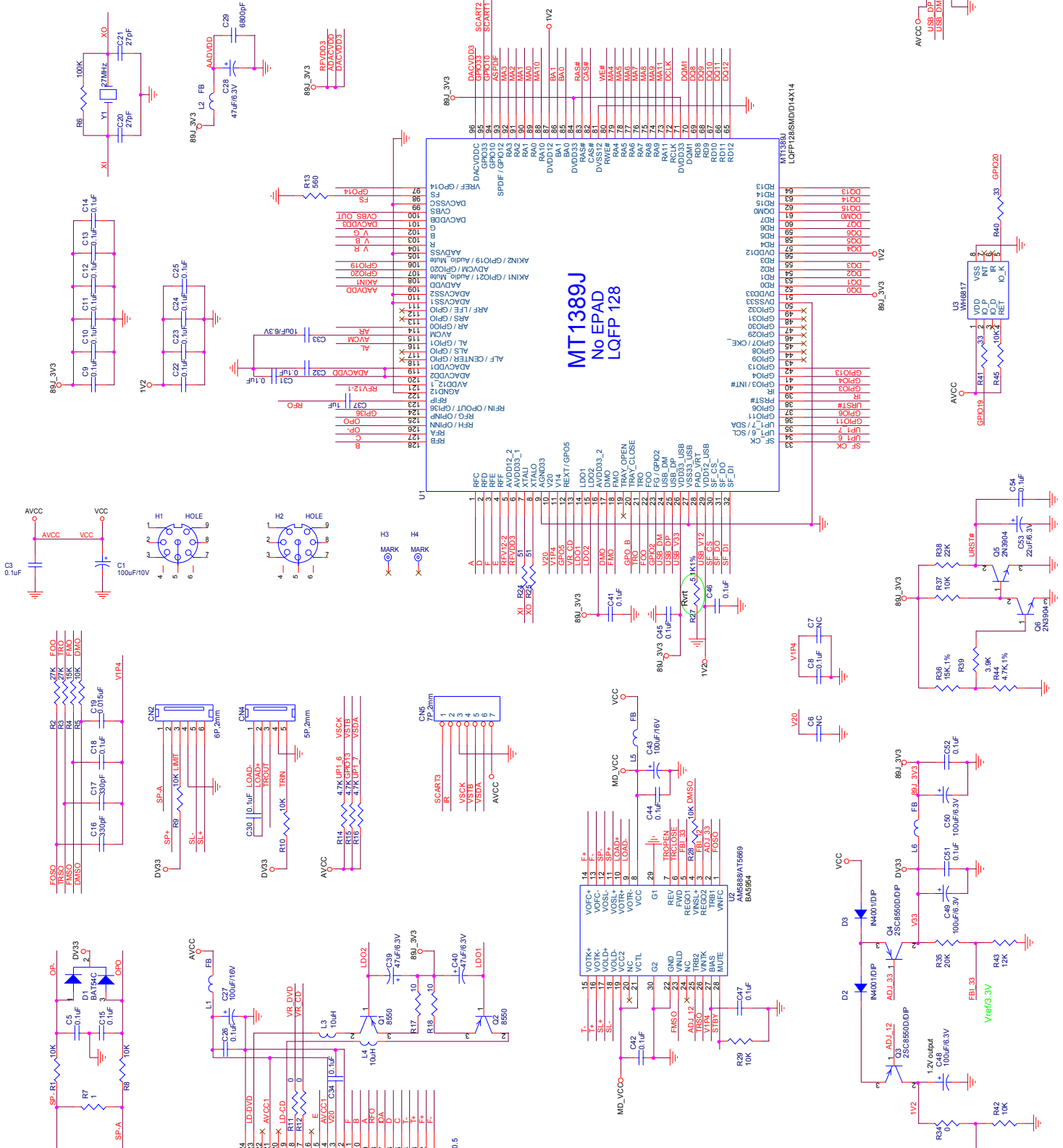
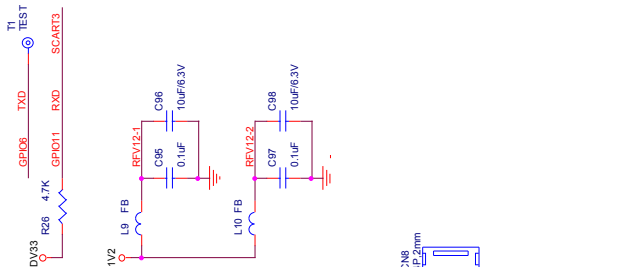
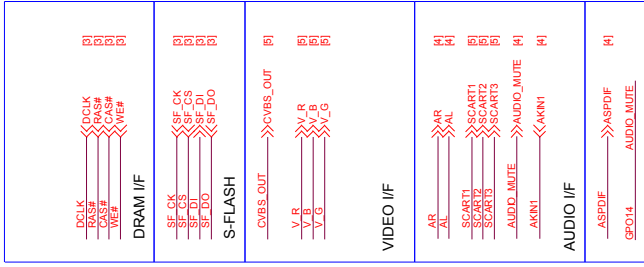

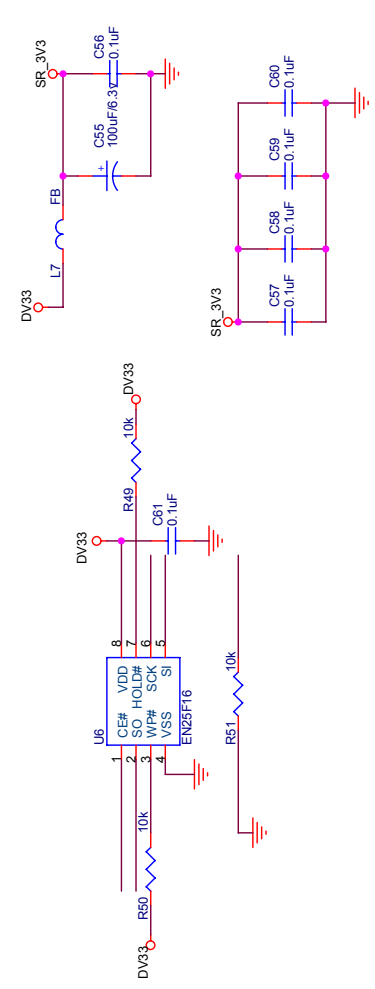
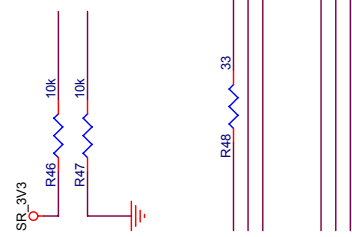
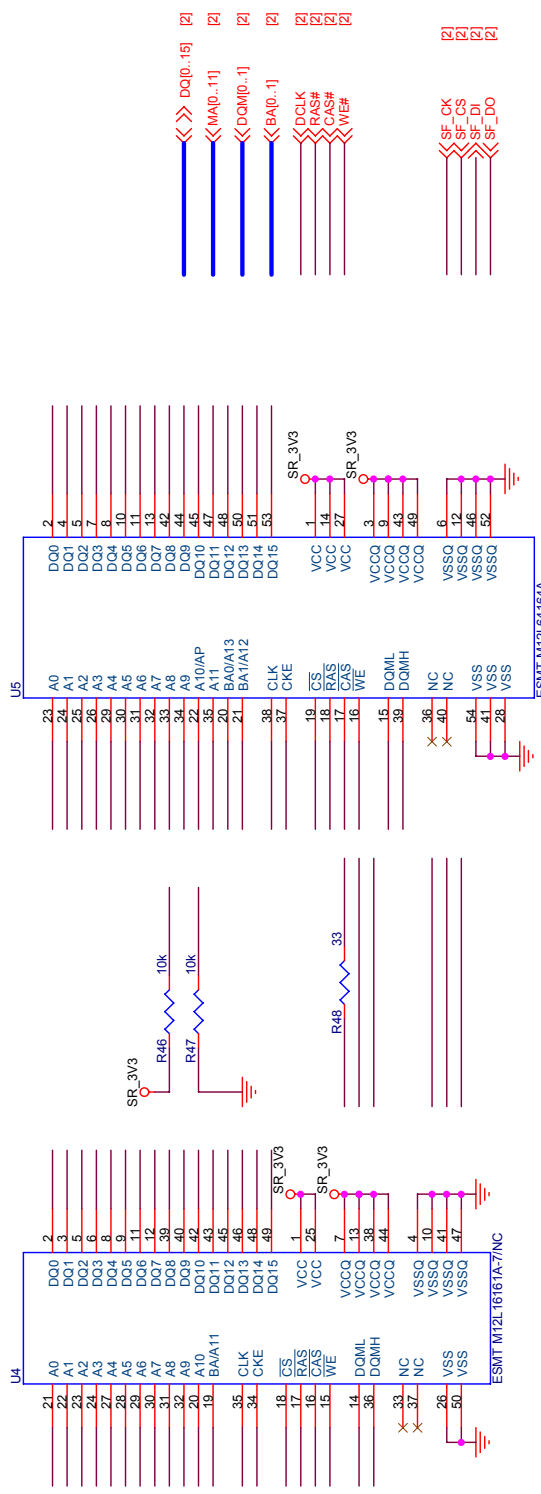

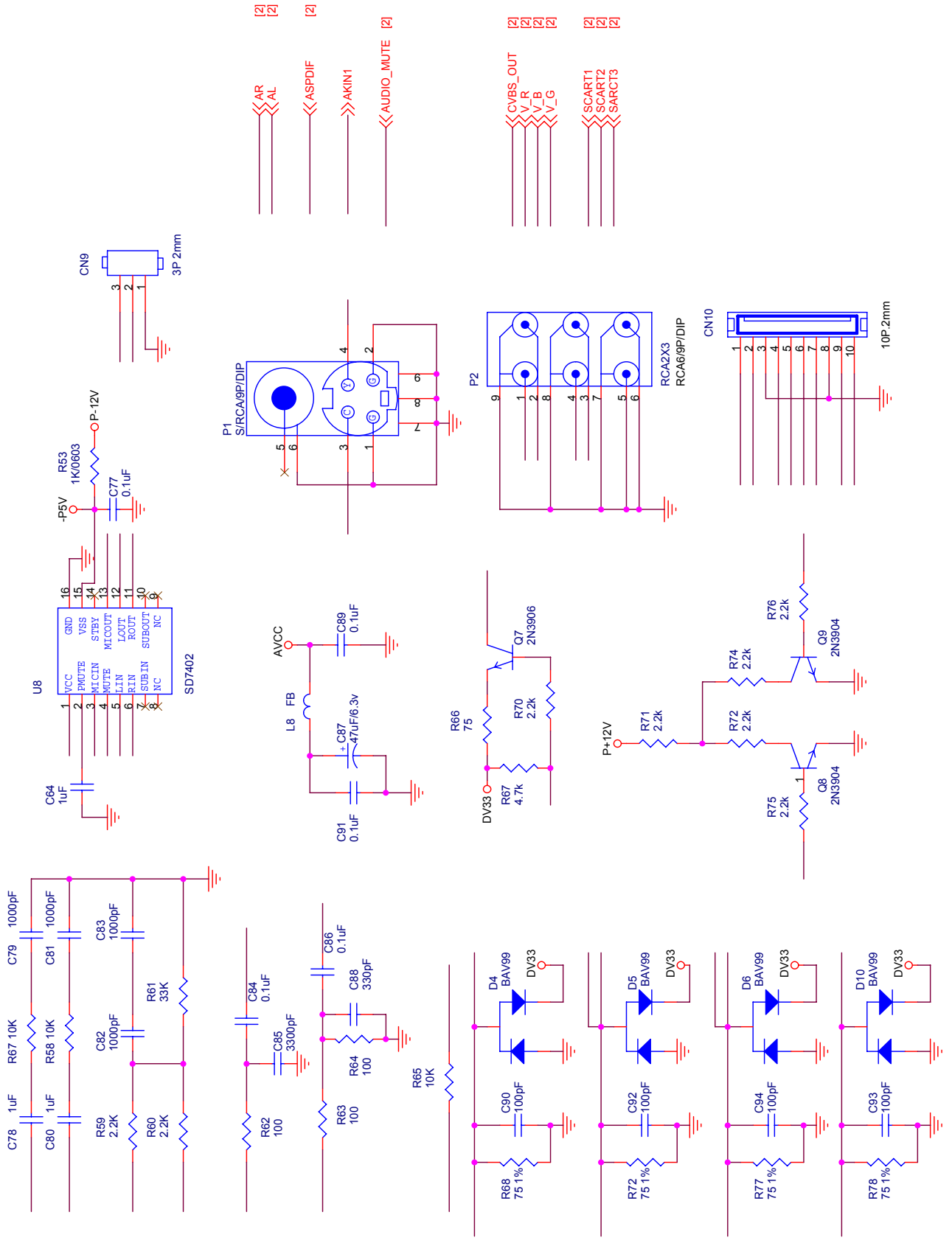

8.2 Power Board

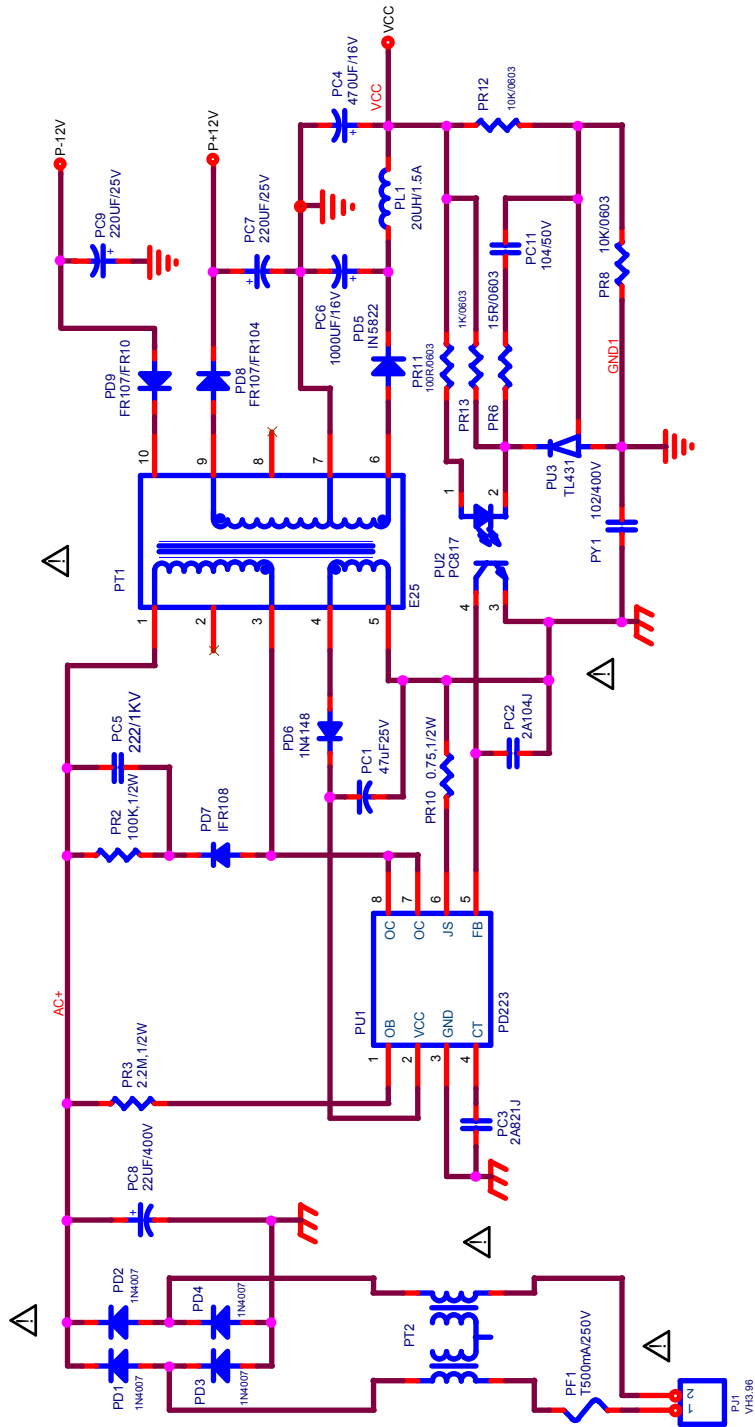

8.3 Main Panel(DV437SI)

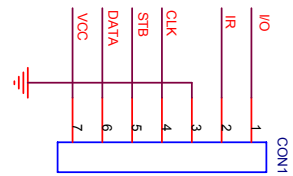
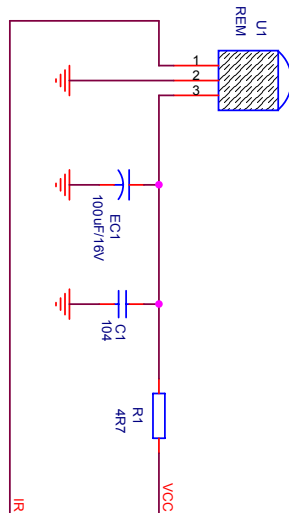
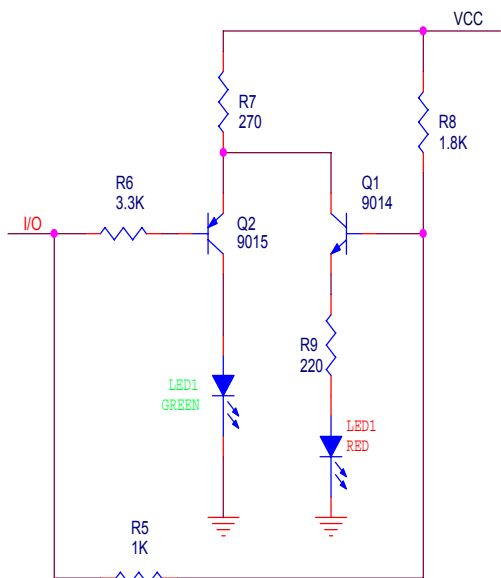
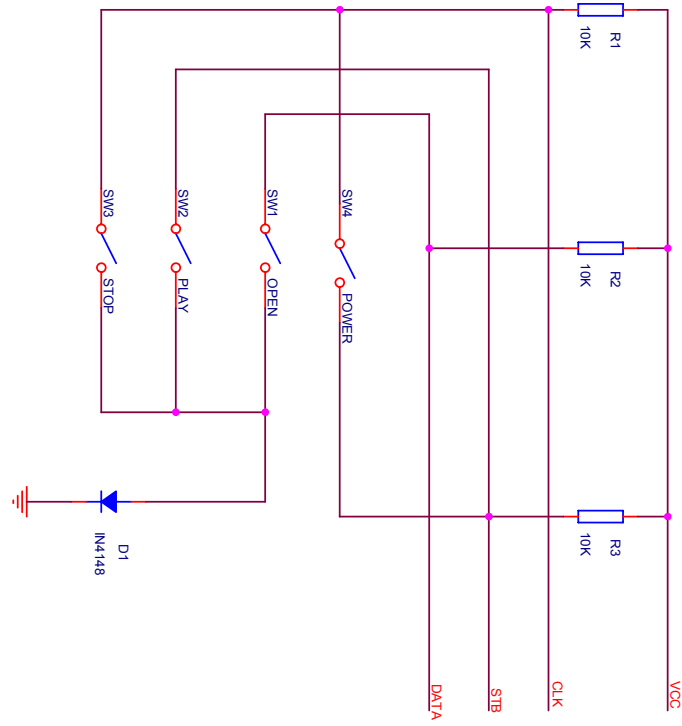

8.4 Main Panel (DV438SI)

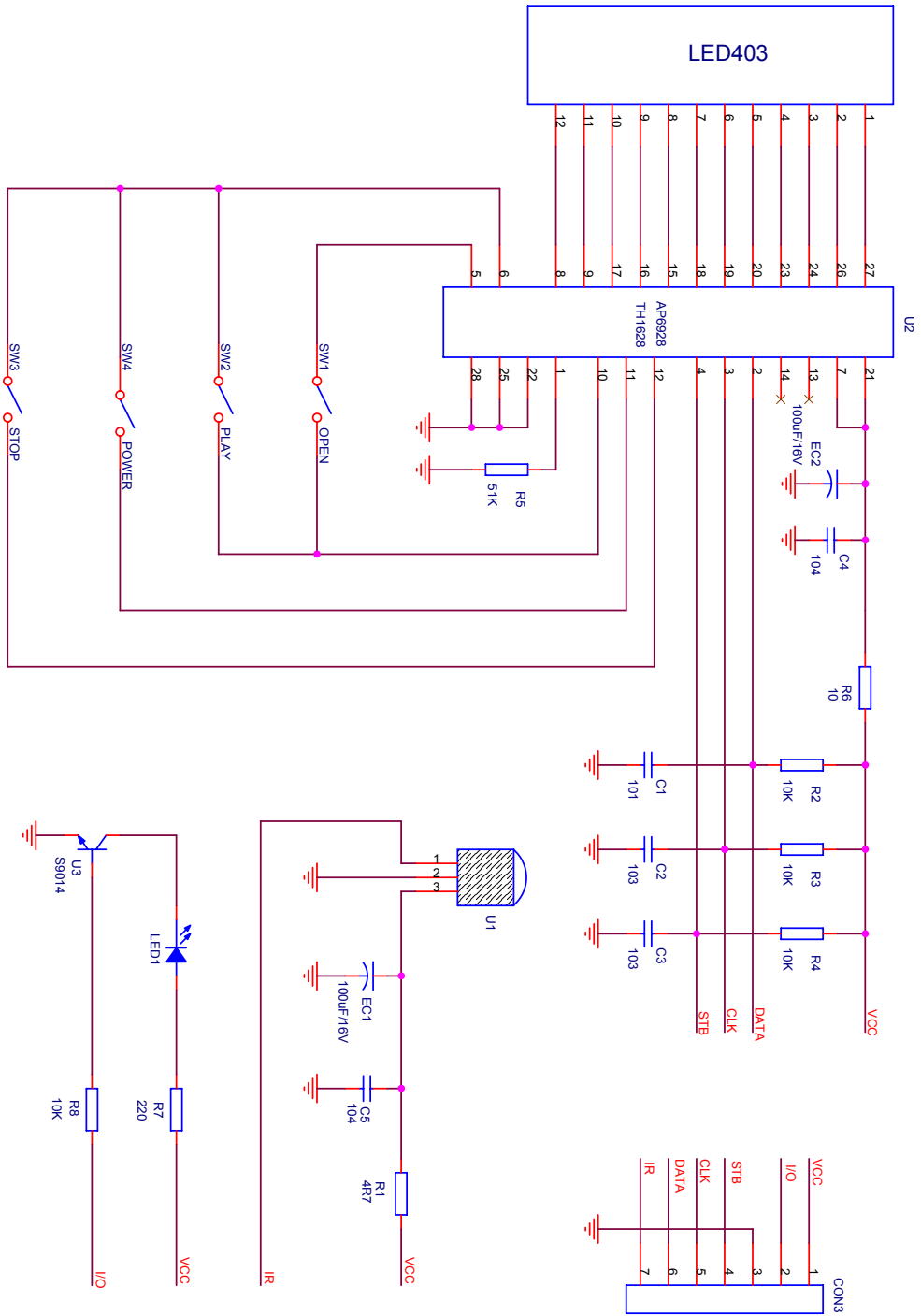

8.5 USB Board

