

**1A LOW DROPOUT LINEAR REGULATOR****AZ1117****General Description**

The AZ1117 is a series of low dropout three-terminal regulators with a dropout of 1.15V at 1A output current capability.

The AZ1117 has an adjustable version, that can provide the output voltage from 1.25V to 12V with only 2 external resistors.

The AZ1117 series provides current limiting and thermal shutdown. Its circuit includes a trimmed bandgap reference to assure output voltage accuracy to be within 1%. Current limit is trimmed to ensure specified output current and controlled short-circuit current. On-chip thermal limiting provides protection against any combination of overload and ambient temperature that would create excessive junction temperature.

The AZ1117 series is available in the industry standard SOT-223, SOT-89, TO-220, TO-252 and TO-263 power packages.

**Features**

- Low dropout voltage: 1.15V at 1A output current
- Trimmed current limit
- On-chip thermal limiting
- Standard SOT-223, SOT-89, TO-220, TO-252 and TO-263 packages
- Three-terminal adjustable or fixed 1.5V, 1.8V, 2.5V, 3.3V, 5V
- Current limit and thermal protection
- Operation junction temp.: 0°C to 125°C

**Applications**

- PC Motherboard
- LCD Monitor
- Graphic Card
- DVD-Video Player
- NIC / Switch
- Telecom Equipment
- High Efficiency Linear Regulator
- Printer and other Peripheral Equipment

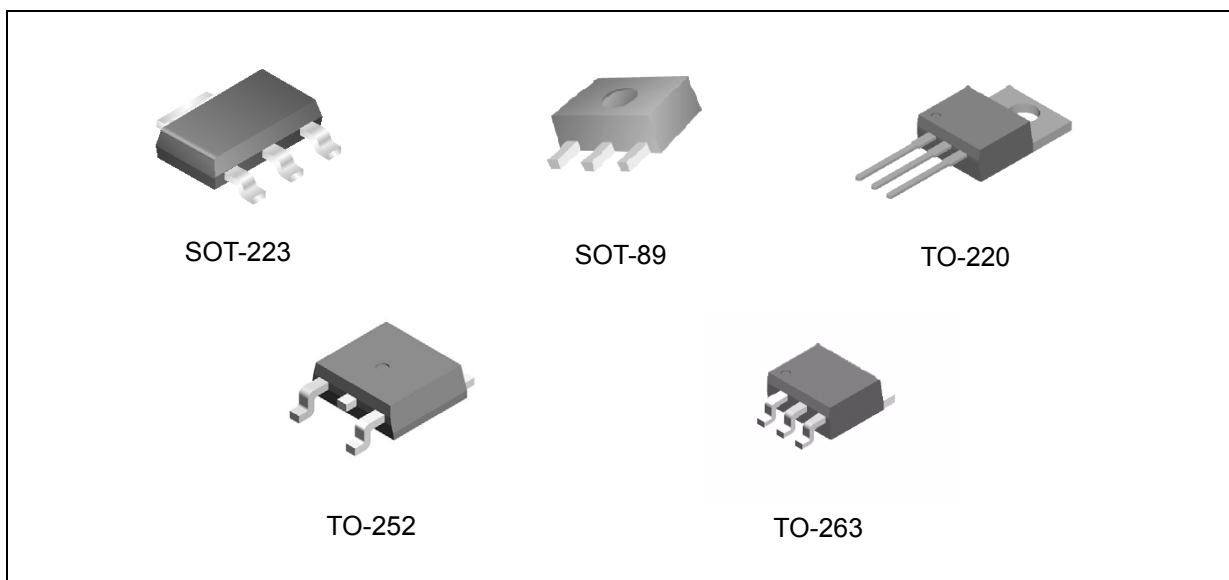

Figure 1. Package Types of AZ1117



**1A LOW DROPOUT LINEAR REGULATOR**

**AZ1117**

**Pin Configuration**

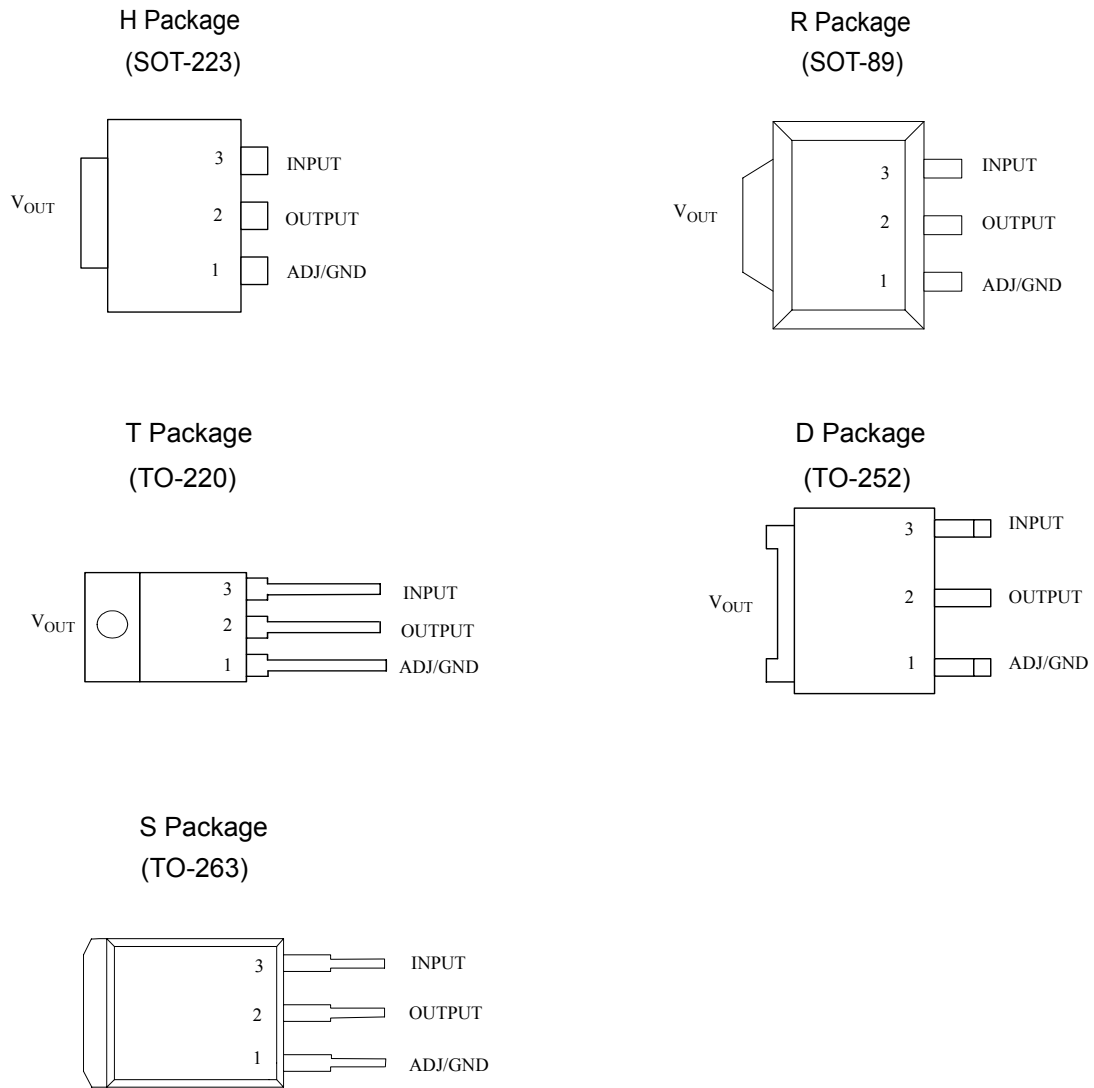

Figure 2. Pin Configuration of AZ1117



**1A LOW DROPOUT LINEAR REGULATOR**

**AZ1117**

**Functional Block Diagram**

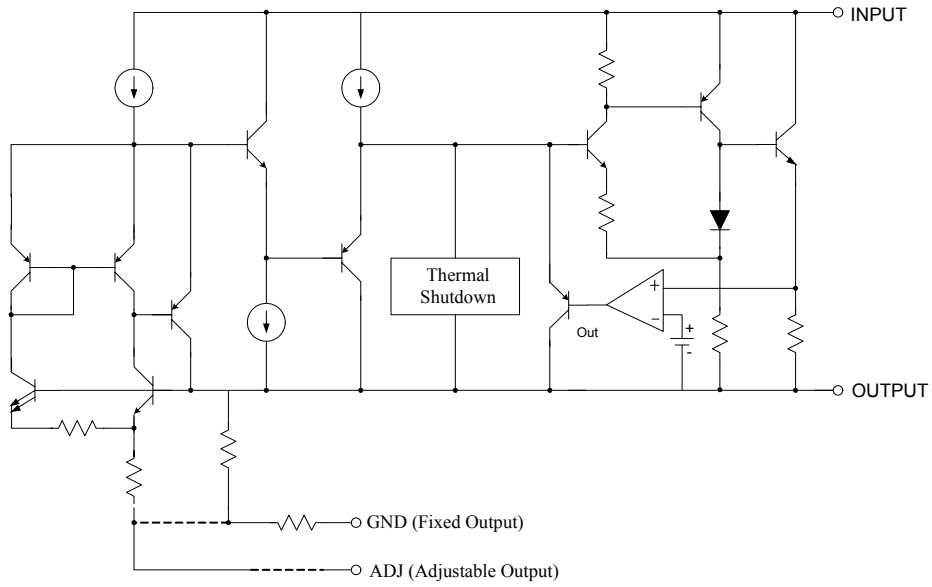

**1A LOW DROPOUT LINEAR REGULATOR****AZ1117****Ordering Information**

Package	Temperature Range	Part Number	Marking ID	Packing Type
SOT-223	0°C~125°C	AZ1117H-ADJ	H11A	Tape/Reel
		AZ1117H-1.5	H12A	Tape/Reel
		AZ1117H-1.8	H13A	Tape/Reel
		AZ1117H-2.5	H14A	Tape/Reel
		AZ1117H-3.3	H16A	Tape/Reel
		AZ1117H-5.0	H17A	Tape/Reel
SOT-89	0°C~125°C	AZ1117R-ADJ	R17A	Tape/Reel
		AZ1117R-1.5	R17B	Tape/Reel
		AZ1117R-1.8	R17C	Tape/Reel
		AZ1117R-2.5	R17D	Tape/Reel
		AZ1117R-3.3	R17E	Tape/Reel
		AZ1117R-5.0	R17F	Tape/Reel
TO-220	0°C~125°C	AZ1117T-ADJ	AZ1117T-ADJ	Tube
		AZ1117T-1.5	AZ1117T-1.5	Tube
		AZ1117T-1.8	AZ1117T-1.8	Tube
		AZ1117T-2.5	AZ1117T-2.5	Tube
		AZ1117T-3.3	AZ1117T-3.3	Tube
		AZ1117T-5.0	AZ1117T-5.0	Tube
TO-252	0°C~125°C	AZ1117D-ADJ	AZ1117D-ADJ	Tape/Reel
		AZ1117D-1.5	AZ1117D-1.5	Tape/Reel
		AZ1117D-1.8	AZ1117D-1.8	Tape/Reel
		AZ1117D-2.5	AZ1117D-2.5	Tape/Reel
		AZ1117D-3.3	AZ1117D-3.3	Tape/Reel
		AZ1117D-5.0	AZ1117D-5.0	Tape/Reel
TO-263	0°C~125°C	AZ1117S-ADJ	AZ1117S-ADJ	Tape/Reel
		AZ1117S-1.5	AZ1117S-1.5	Tape/Reel
		AZ1117S-1.8	AZ1117S-1.8	Tape/Reel
		AZ1117-2.5	AZ1117-2.5	Tape/Reel
		AZ1117-3.3	AZ1117-3.3	Tape/Reel
		AZ1117-5.0	AZ1117-5.0	Tape/Reel

**1A LOW DROPOUT LINEAR REGULATOR****AZ1117****Absolute Maximum Ratings (Note 1)**

Parameter	Value	Unit
V <sub>IN</sub>	20	V
Operating Junction Temperature Range	150	°C
Storage Temperature Range	-65 ~ 150	°C
Lead Temperature (Soldering, 10 sec.)	300	°C
ESD (Machine Model)	600	V

Note 1: Stresses greater than those listed under "Absolute Maximum Ratings " may cause permanent damage to the device. These are stress ratings only, and functional operation of the device at these or any other conditions beyond those indicated under "Recommended Operation Ratings " is not implied. Exposure to "Absolute Maximum Ratings " for extended periods may affect device reliability.

**Recommended Operating Ratings**

Parameter	Min	Max	Unit
V <sub>IN</sub>		15	V
Operating Junction Temperature Range	0	125	°C
Storage Temperature Range	-65	150	°C



**1A LOW DROPOUT LINEAR REGULATOR**

**AZ1117**

**Electrical Characteristics**

(Typicals and limits apply for  $T_J = 25^\circ\text{C}$  unless otherwise specified.)

Parameter	Symbol	Conditions	Min	Typ	Max	Unit
Reference Voltage	$V_{REF}$	$V_{IN} - V_{OUT} = 2V, T_J = 25^\circ\text{C}$ $10\text{mA} \leq I_{OUT} \leq 1A, 1.4V \leq (V_{IN} - V_{OUT}) \leq 10V$	1.238	1.250	1.263	V
Output Voltage	$V_{OUT}$	AZ1117-1.5, $T_J = 25^\circ\text{C}$ , $0 \leq I_{OUT} \leq 1A, 3V \leq V_{IN} \leq 8V$	1.485	1.5	1.515	V
		AZ1117-1.8, $T_J = 25^\circ\text{C}$ , $0 \leq I_{OUT} \leq 1A, 3.2V \leq V_{IN} \leq 10V$	1.782	1.8	1.818	V
		AZ1117-2.5, $T_J = 25^\circ\text{C}$ , $0 \leq I_{OUT} \leq 1A, 3.9V \leq V_{IN} \leq 10V$	2.475	2.5	2.525	V
		AZ1117-3.3, $T_J = 25^\circ\text{C}$ , $0 \leq I_{OUT} \leq 1A, 4.75V \leq V_{IN} \leq 10V$	3.267	3.3	3.33	V
		AZ1117-5.0, $T_J = 25^\circ\text{C}$ , $0 \leq I_{OUT} \leq 1A, 6.5V \leq V_{IN} \leq 12V$	4.95	5.0	5.05	V
Line Regulation	$S_V$	$I_{OUT} = 10\text{mA}, 1.5V \leq V_{IN} - V_{OUT} \leq 10V$		0.035		%
Load Regulation	$S_i$	$V_{IN} - V_{OUT} = 2V, 10\text{mA} \leq I_{OUT} \leq 1A$		0.15		%
Dropout Voltage	$\Delta V$	$I_{OUT} = 100\text{mA}$		1.00	1.1	V
		$I_{OUT} = 500\text{mA}$		1.08	1.18	V
		$I_{OUT} = 1A$		1.15	1.25	V
Current Limit	$I_{limit}$	$(V_{IN} - V_{OUT}) = 2V$		1.50		A
Adjust Pin Current				60		$\mu\text{A}$
Adjust Pin Current Change		$1.4V \leq (V_{IN} - V_{OUT}) \leq 7V, 10\text{mA} \leq I_{OUT} \leq 1A$		0.2		$\mu\text{A}$
Minimum Load Current (ADJ)		$1.5V \leq (V_{IN} - V_{OUT}) \leq 15V$		2		mA
Quiescent Current		$V_{IN} = V_{OUT} + 1.25V$		5		mA
Ripple Rejection		$f = 120\text{Hz}, C_{OUT} = 22\mu\text{F Tantalum}$ , $(V_{IN} - V_{OUT}) = 3V, I_{OUT} = 1A$	60	75		dB
Temperature Stability				0.5		%
Long -Term Stability		$A = 125^\circ\text{C}, 1000\text{hrs}$		0.3		%
RMS Output Noise(% of $V_{OUT}$ )		$T_A = 25^\circ\text{C}, 10\text{Hz} \leq f \leq 10\text{kHz}$		0.003		%
Thermal Resistance, Junction to Case		SOT-223		15		$^\circ\text{C/W}$
		TO-252		10		
		TO-220		4.5		
Thermal Shutdown		Junction Temperature		150		$^\circ\text{C}$
Thermal Shutdown Hysteresis				25		$^\circ\text{C}$



**1A LOW DROPOUT LINEAR REGULATOR**

**AZ1117**

**Typical Characteristics**

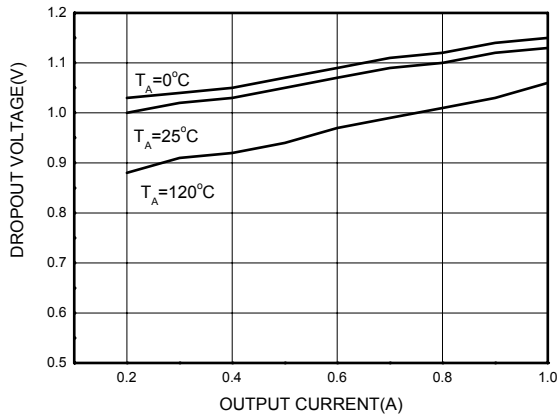

Figure 4. Dropout Voltage vs. Output Current

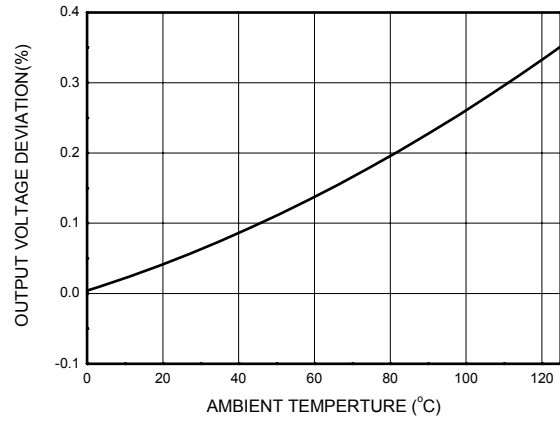

Figure 5. Load Regulation vs. Temperature

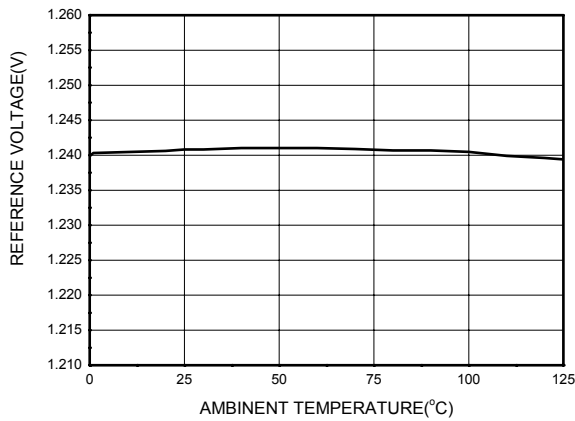

Figure 6. Reference Voltage vs. Temperature

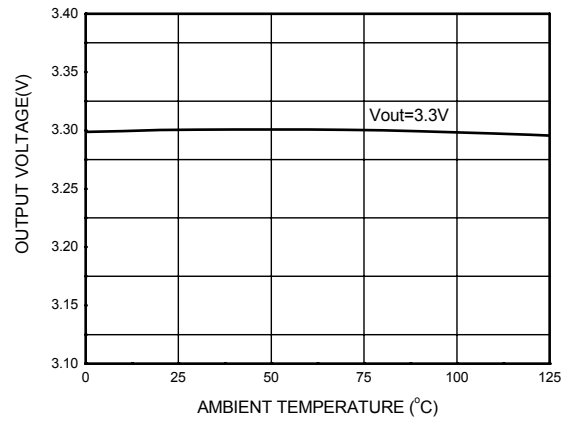

Figure 7. Output Voltage vs. Temperature



1A LOW DROPOUT LINEAR REGULATOR

AZ1117

Typical Characteristics (Continued)

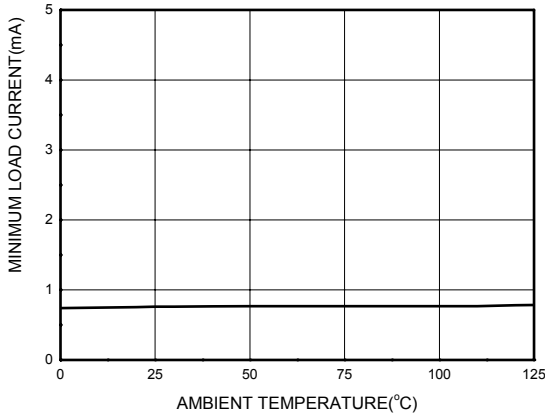

Figure 8. Minimum Load Current vs. Temperature

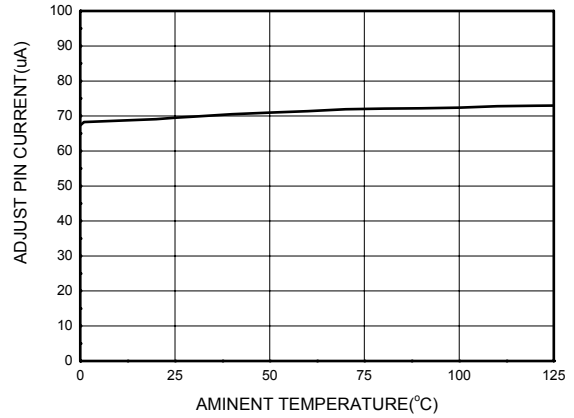

Figure 9. Adjust Pin Current vs. Temperature

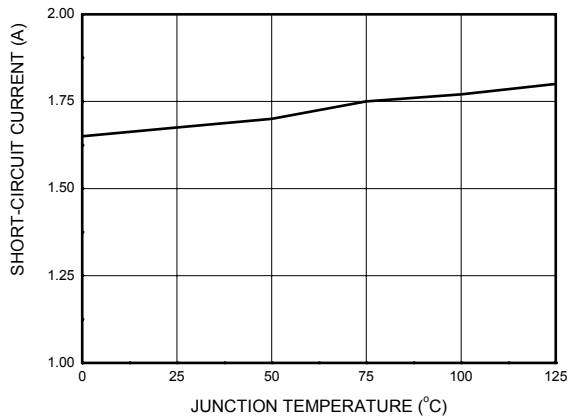

Figure 10. Short-Circuit Current vs. Temperature

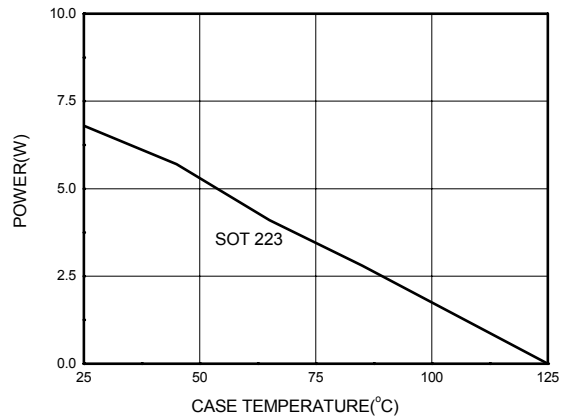

Figure 11. Maximum Power Dissipation





1A LOW DROPOUT LINEAR REGULATOR

AZ1117

Typical Characteristics (Continued)

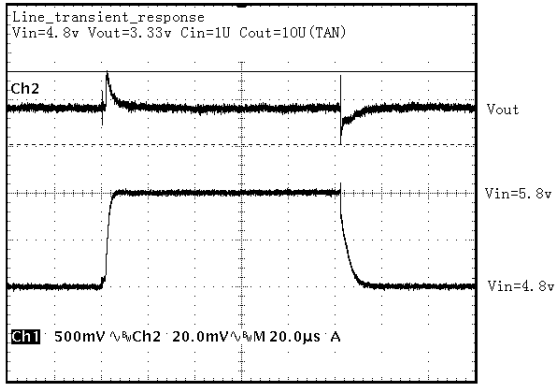

Figure 12. Line Transient Response

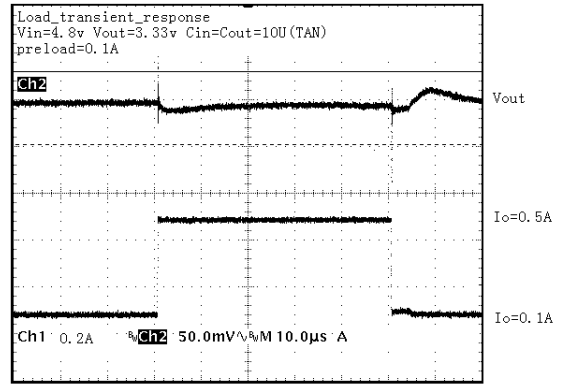

Figure 13. Load Transient Response

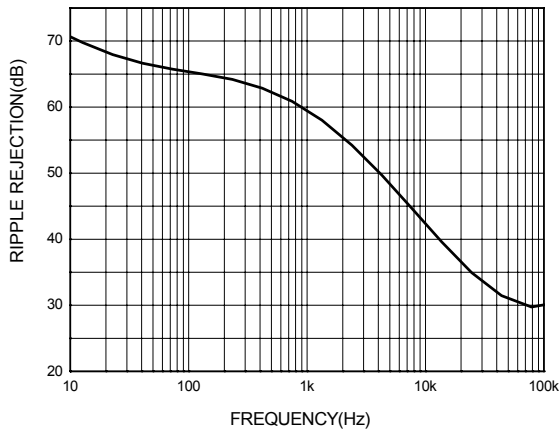

Figure 14. Ripple Rejection vs. Frequency



1A LOW DROPOUT LINEAR REGULATOR

AZ1117

Typical Applications

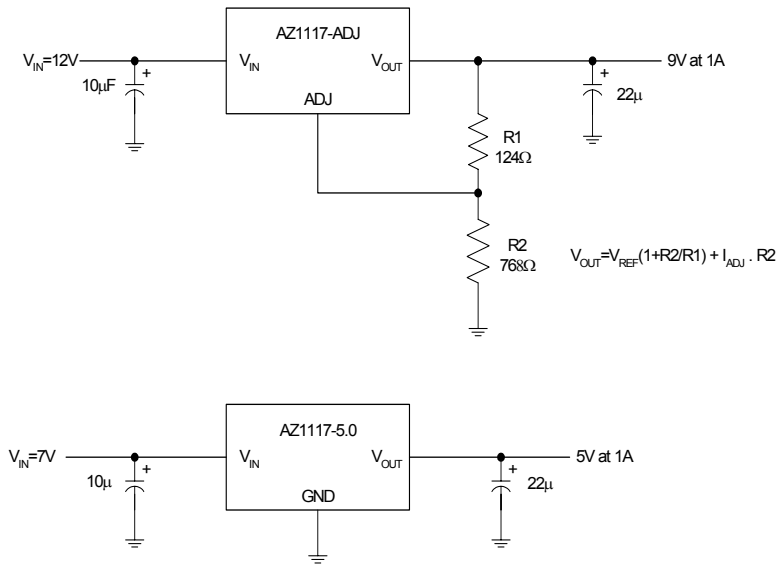

Figure 15. Typical Applications of AZ1117



1A LOW DROPOUT LINEAR REGULATOR

AZ1117

Mechanical Dimensions

SOT - 223

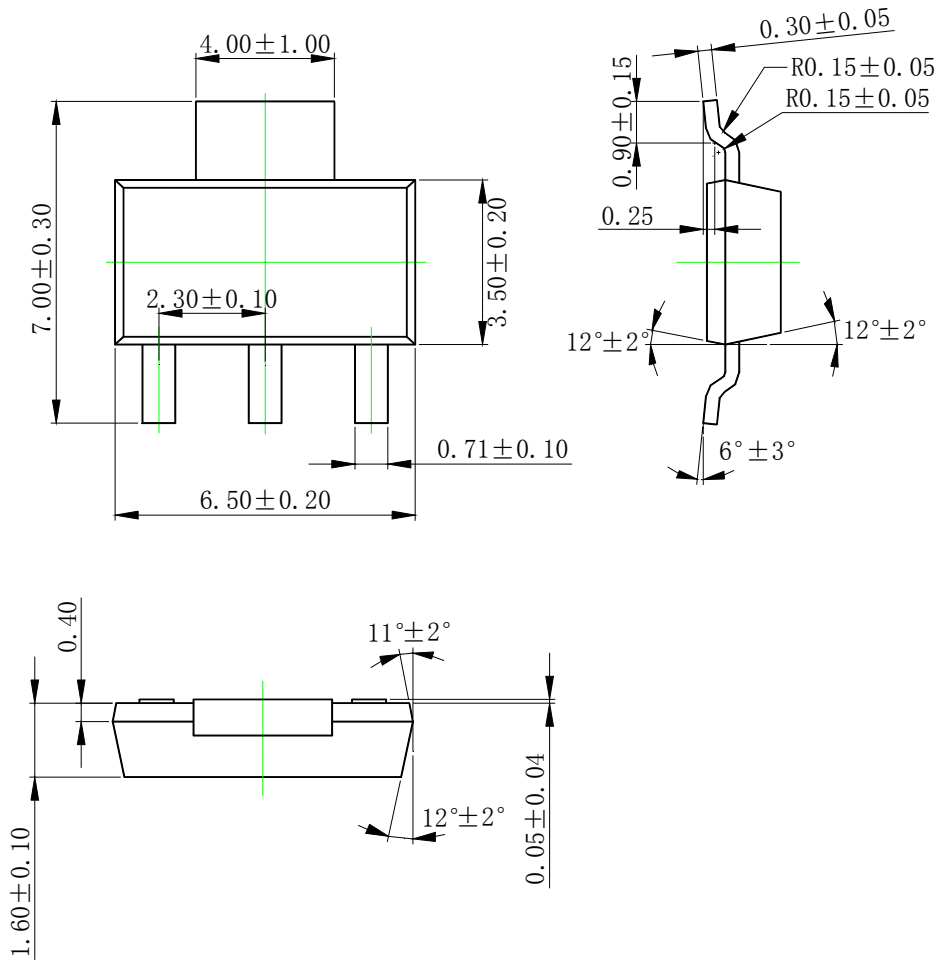



1A LOW DROPOUT LINEAR REGULATOR

AZ1117

Mechanical Dimensions (Continued)

SOT-89

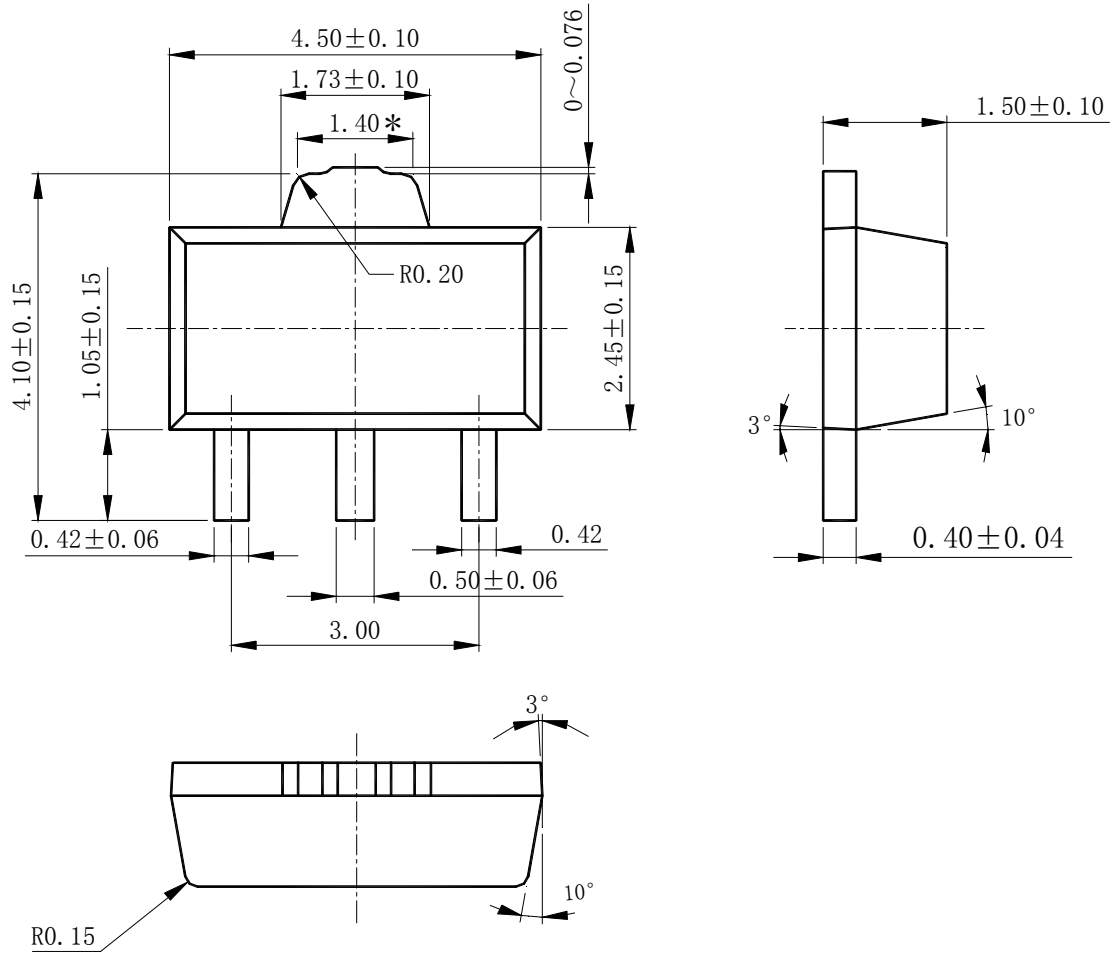



1A LOW DROPOUT LINEAR REGULATOR

AZ1117

Mechanical Dimensions (Continued)

TO - 252

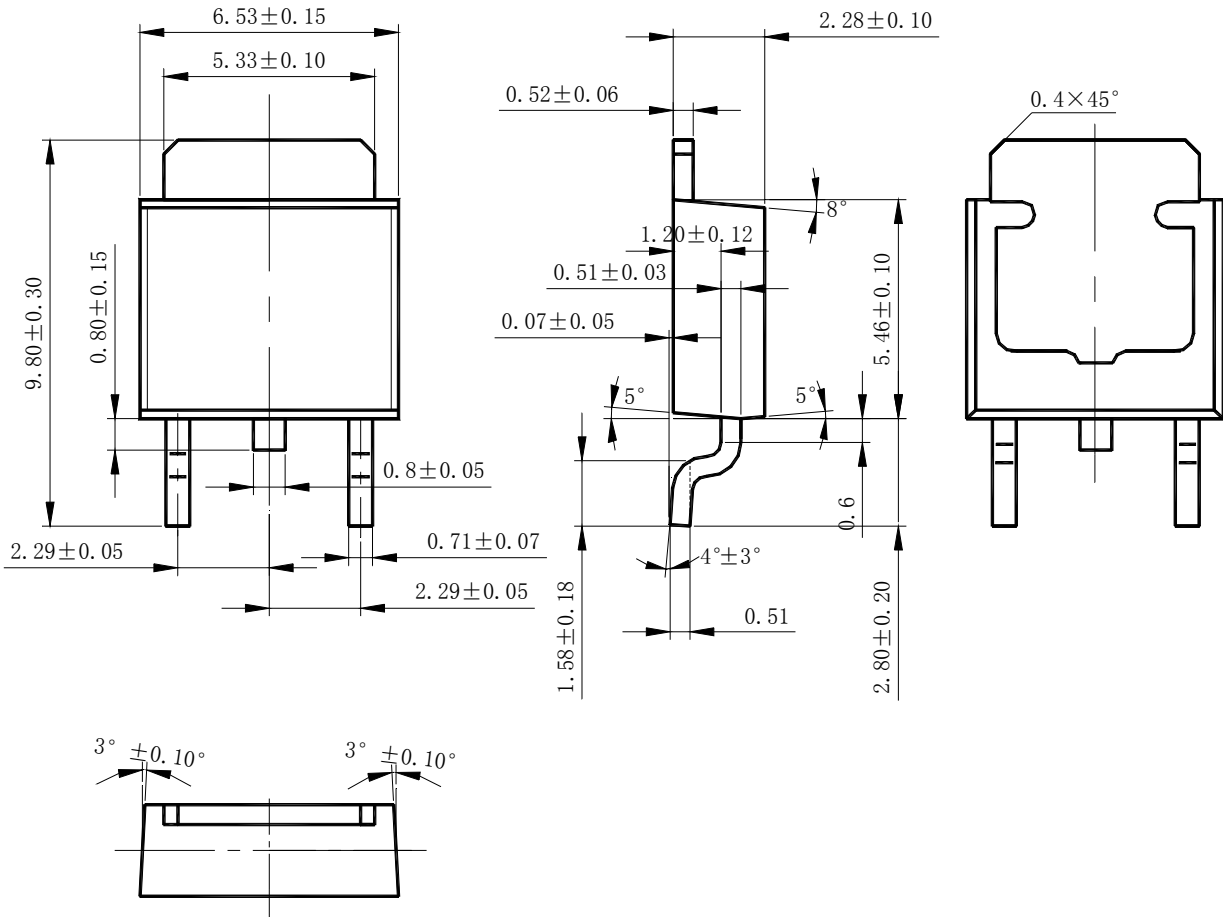



1A LOW DROPOUT LINEAR REGULATOR

AZ1117

Mechanical Dimensions (Continued)

TO - 220

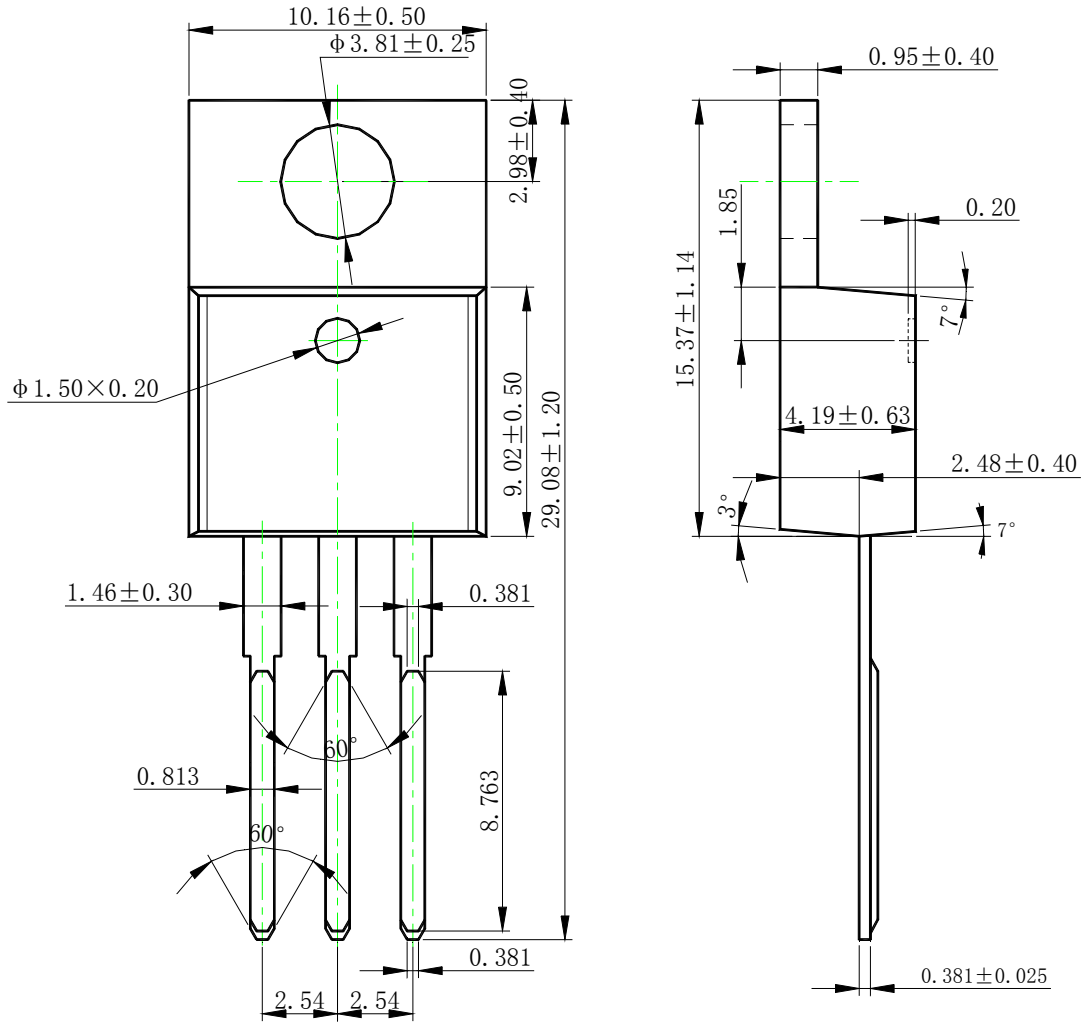



1A LOW DROPOUT LINEAR REGULATOR

AZ1117

Mechanical Dimensions (Continued)

TO - 263

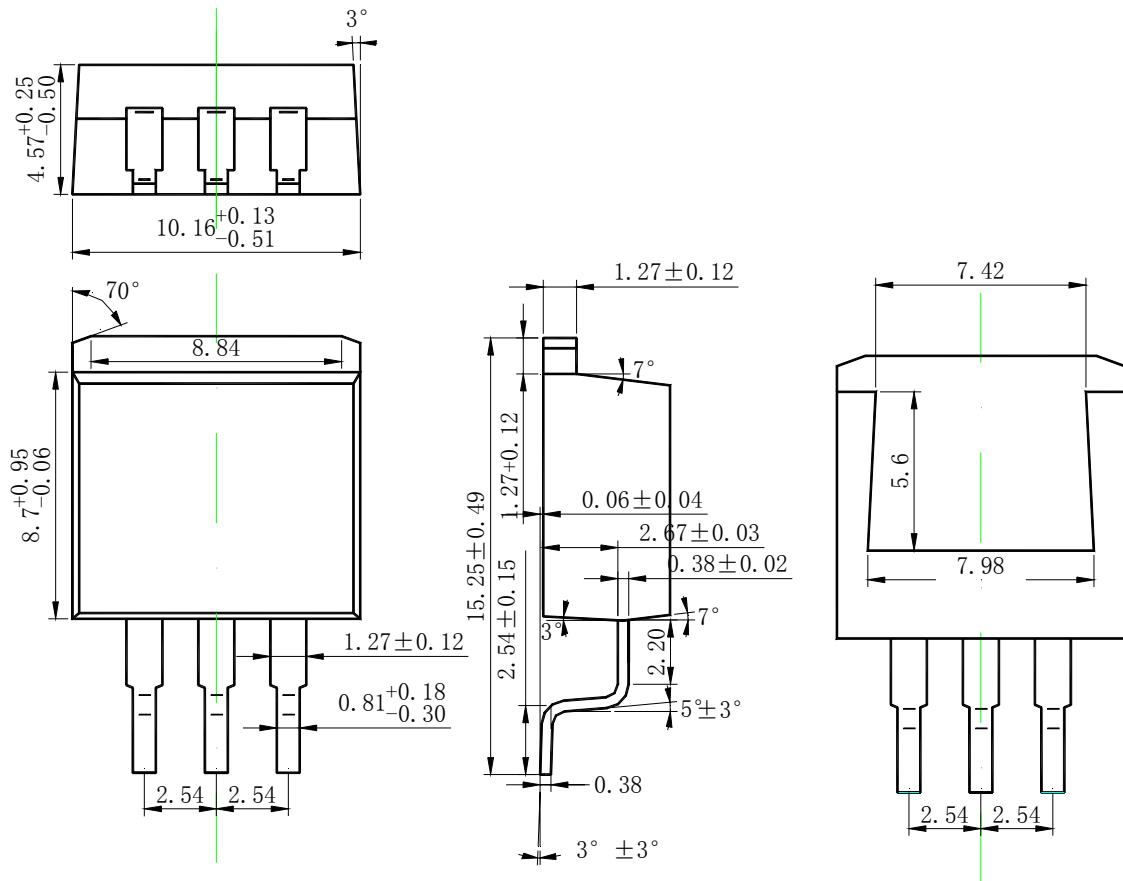



<http://www.aacmicro.com>

---

**USA:** 1510 Montague Expressway, San Jose, CA 95131, USA

Tel: 408-433 9888, Fax: 408-432 9888

**China:** 8th Floor, Zone B, 900 Yi Shan Road, Shanghai 200233, China

Tel: 86-21-6495 9539, Fax: 86-21-6485 9673

**Taiwan:** Room 2210, 22nd Fl, 333, Keelung Road, Secretary 1, Taipei, Taiwan

Tel: 886-2-2564 3699, Fax: 886-2-2564 3770

#### **IMPORTANT NOTICE**

Advanced Analog Circuits Corporation reserves the right to make changes to its products or specifications at any time, without notice, to improve design or performance and to supply the best possible product. Advanced Analog Circuits does not assume any responsibility for use of any circuitry described other than the circuitry embodied in Advanced Analog Circuits' products. The company makes no representation that circuitry described herein is free from patent infringement or other rights of Advanced Analog Circuits Corporation.