

# **LCD TV TRAINING MANUAL**

**UD6500**

**UD6400**

**UD6900**



# Agenda



- I. Inside of *UD6500*
- II. New Part of UD6500
- III. Board description
- IV. Disassembly
- V. Trouble Shooting

# Inside of UD6V

SAMSUNG

Items		Specification
Model Name		UN46D6500VFXZA
General	Size (W*D*H) with Stand	1068.40 x 275.0 x 683.60 (mm)
	Weight with Stand	16.7 (kg)
	Panel Resolution	1920*1080
	A/V	2AV
	S-Video	X
	DVD	1 component 480i/p,720p,1080i/p
	PC	1 Dsub
	HDMI	4 HDMI
	Tuner	1 ATSC/Half NIM/QAM tuner
	Sound Output	6 ohm, 10W
	PIP	O
	Sound option	SRS TruSurround HD
	DNIe	O
	Headphone	X
	Response time	4ms
	Luminance [cd/m2, typical]	500
	C/R	50000:1
	Anynet+ (hdmi cec)	O
	View Angle(H/V)	178/178
	Power Supply	AC 110~220V,60Hz
Power Consumption	<210W	
Color System	NTSC	
Sound System	PCM	

# Spec Comparison





Model		SAMSUNG (UD6500 46") UN46D6500VFXZA	SAMSUNG (LC6400 46") UN46C6400RFXZA
Design			
Set	Size	1068.4 x 275.0 x 683.6 mm	998.0 X 300.0 X 703.5 mm
Panel	Size	Diagonal 46"	Diagonal 46"
	Resolution	1920 x 1080	1920 x 1080
	Viewing angle	H : 178 V : 178	H : 178 V : 178
Color System		ATSC / NTSC	ATSC / NTSC
Tuner		1	1
Function	Contrast (cd/m <sup>2</sup> )	500	500
	CR ( Dynamic )	50000 : 1	50000 : 1
	Enhancer	DNle(FBE3)	DNle(FBE3)
Additional Function		Contents library Internet@TV Media Play (USB&DLNA) (MPEG)	Contents library Internet@TV Media Play (USB&DLNA) (MPEG)
Power Consumption		200W	200W

# Control & Connection Panel

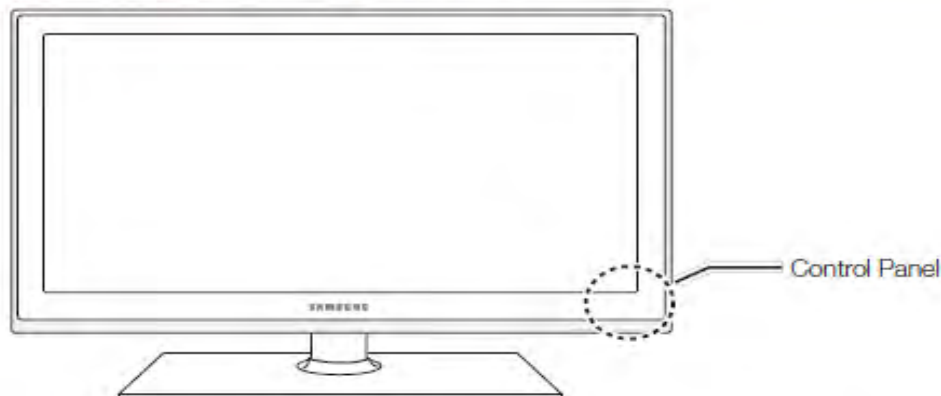
## Viewing the Control Panel

 The product color and shape may vary depending on the model.



Remote control sensor	Aim the remote control towards this spot on the TV.
Power Indicator	Blinks and turns off when the power is on and lights up in standby mode.
SOURCE 	Toggles between all the available input sources. In the on-screen menu, use this button as you would use the <b>ENTER</b>  button on the remote control.
MENU 	Displays an on-screen menu, the OSD (on screen display) of your TV's features.
-VOL+	Adjusts the volume. In the OSD, use the <b>-VOL+</b> buttons as you would use the <b>◀</b> and <b>▶</b> buttons on the remote control.
▼ CH ▲	Changes the channels. In the OSD, use the <b>▼ CH ▲</b> buttons as you would use the <b>▼</b> and <b>▲</b> buttons on the remote control.
 (Power)	Turns the TV on or off.

### Standby mode

Do not leave your TV in standby mode for long periods of time (when you are away on a holiday, for example). A small amount of electric power is still consumed even when the power button is turned off. It is best to unplug the power cord.

# Control & Connection Panel

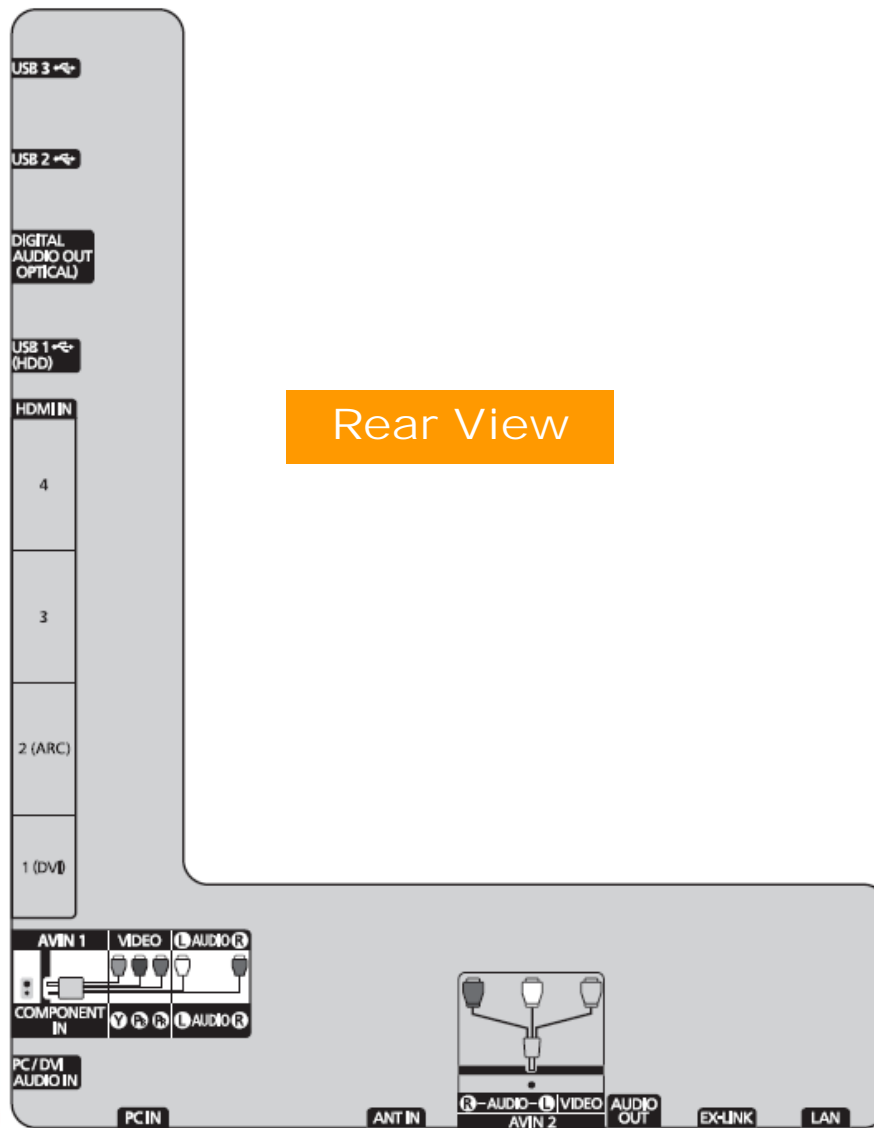

Rear View



# Control & Connection Panel

## Connecting to an Antenna

When the TV is initially powered on, basic settings proceed automatically.

 Connecting the power cord and antenna.

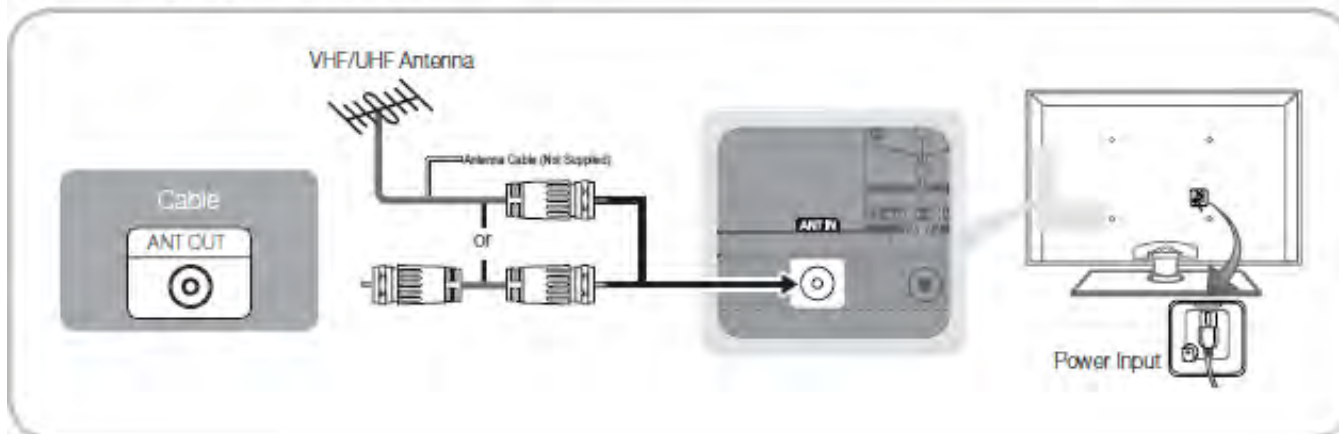



# Control & Connection Panel

## Connecting to an AV Device

### Using an HDMI or an HDMI to DVI Cable: HD connection (up to 1080p)

We recommend using the HDMI connection for the best quality HD picture.

Available devices: DVD, Blu-ray player, HD cable box, HD STB (Set-Top-Box) satellite receiver

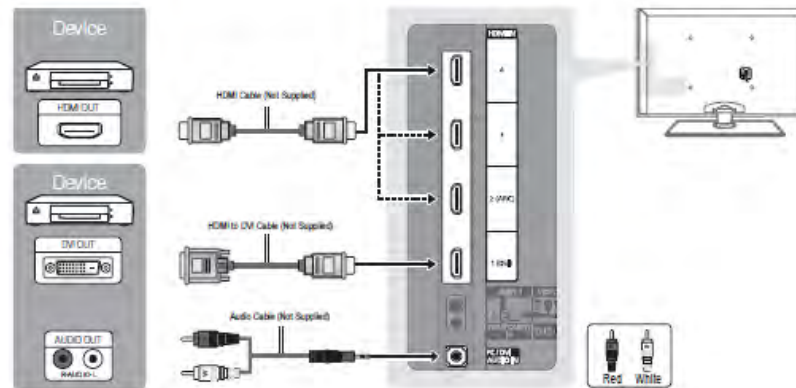

### HDMI IN 1(DVI), 2(ARC), 3, 4, PC/DVI AUDIO IN

- For better picture and audio quality, connect to a digital device using an HDMI cable.
- An HDMI cable supports digital video and audio signals, and does not require an audio cable.
  - To connect the TV to a digital device that does not support HDMI output, use an HDMI/DVI and audio cables.
- The picture may not display normally (if at all) or the audio may not work if an external device that uses an older version of HDMI mode is connected to the TV. If such a problem occurs, ask the manufacturer of the external device about the HDMI version and, if out of date, request an upgrade.
- Be sure to use an HDMI cable with a thickness of 14 mm or less.
- Be sure to purchase a certified HDMI cable. Otherwise, the picture may not display or a connection error may occur.
- A basic high-speed HDMI cable or one with ethernet is recommended. This product does not support the ethernet function via HDMI.
- This product supports the 3D and ARC (Audio Return Channel) functions via an HDMI cable. Note that the ARC function is supported by the HDMI IN 2(ARC) port only.
  - If **3D Auto View** is set to **On**, some functions such as **SMART HUB** may be disabled. In this case, set **3D Auto View** or **3D Mode** to **Off**.
- The ARC function allows digital audio to output via the HDMI IN 2(ARC) port. It can be enabled only when the TV is connected with an audio receiver that supports the ARC function.

# Control & Connection Panel

## Connecting to an Audio Device

### Using an Optical (Digital) or an Audio (Analog) Cable Connection

Available devices: Digital Audio System, Amplifier, DVD home theater

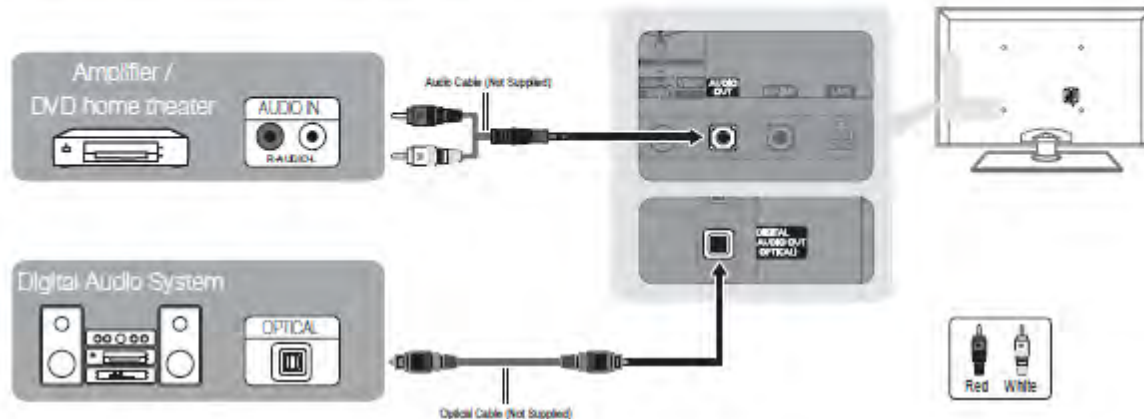

#### DIGITAL AUDIO OUT (OPTICAL)

- When a Digital Audio System is connected to the DIGITAL AUDIO OUT (OPTICAL) jack, decrease the volume of both the TV and the system.
- 5.1 CH (channel) audio is available when the TV is connected to an external device supporting 5.1 CH.
- When the receiver (home theater) is set to on, you can hear sound output from the TV's optical jack. When the TV is receiving a DTV signal, the TV will send 5.1 CH sound to the home theater receiver. When the source is a digital component such as a DVD / Blu-ray player / cable box / STB (Set-Top-Box) satellite receiver and is connected to the TV via HDMI, only 2 CH audio will be heard from the home theater receiver. If you want to hear 5.1 CH audio, connect the digital audio out jack from your DVD / Blu-ray player / cable box / STB satellite receiver directly to an amplifier or home theater.

#### AUDIO OUT: Connects to the audio Input Jacks on your amplifier/DVD home theater.

- When connecting, use the appropriate connector.
- When an audio amplifier is connected to the AUDIO OUT jacks: Decrease the volume of the TV and adjust the volume level with the amplifier's volume control.

# Remote control

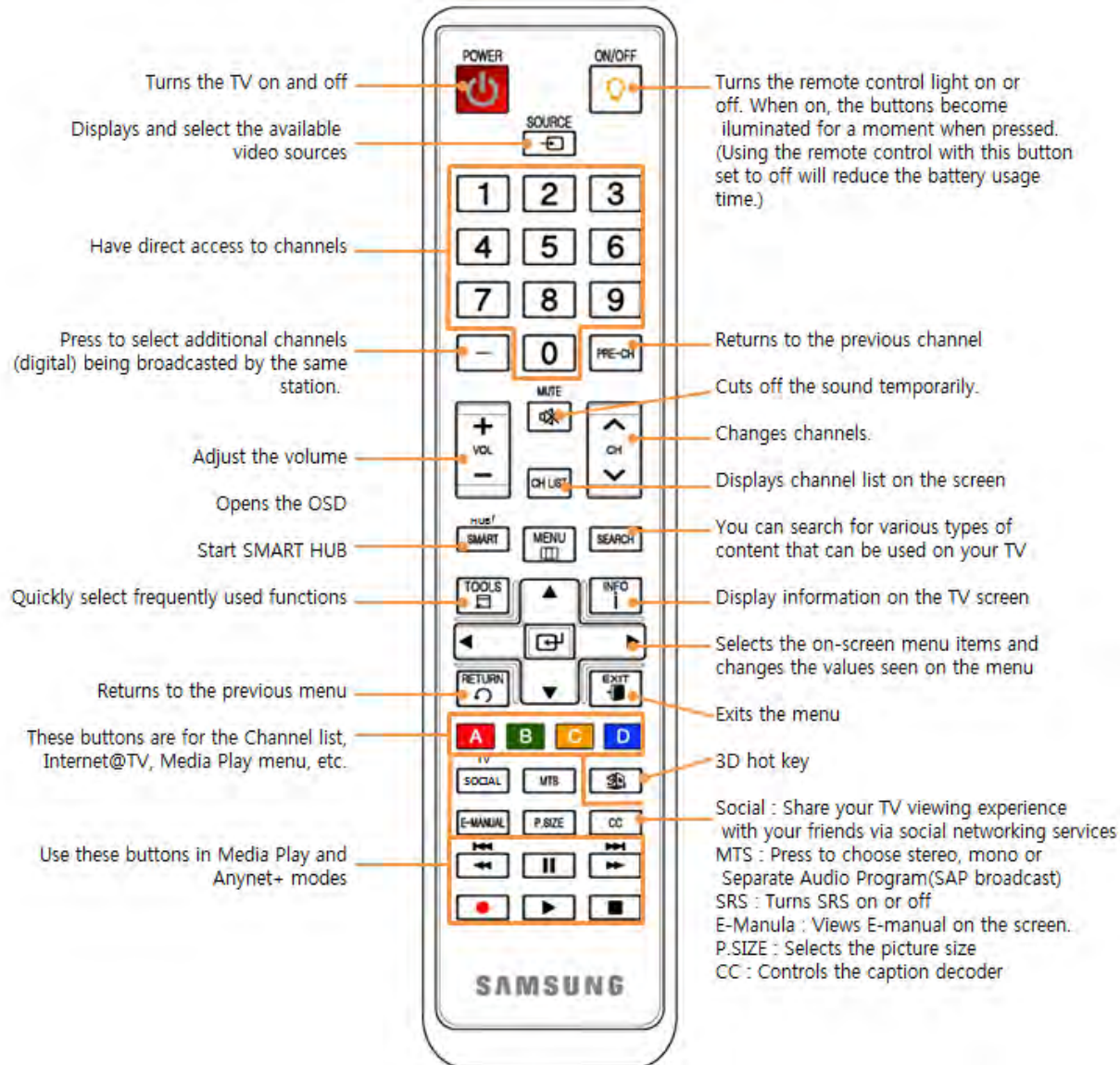



# Inner Feature of UD6V

IP Board, Main Board, Panel

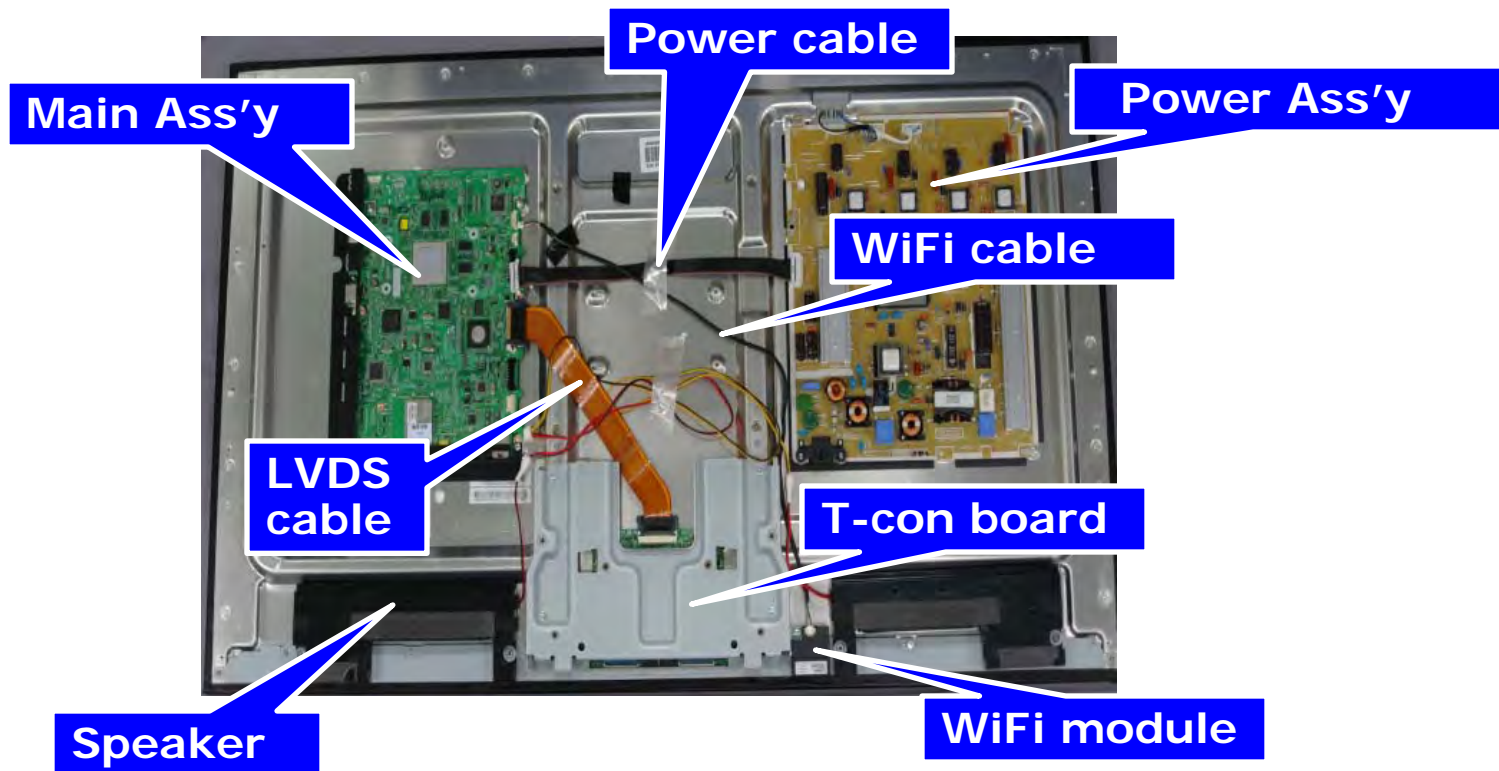

# Inner Feature of UD6000 32" / 40" / 46" / 55"

- IP Board, Main Board, Panel

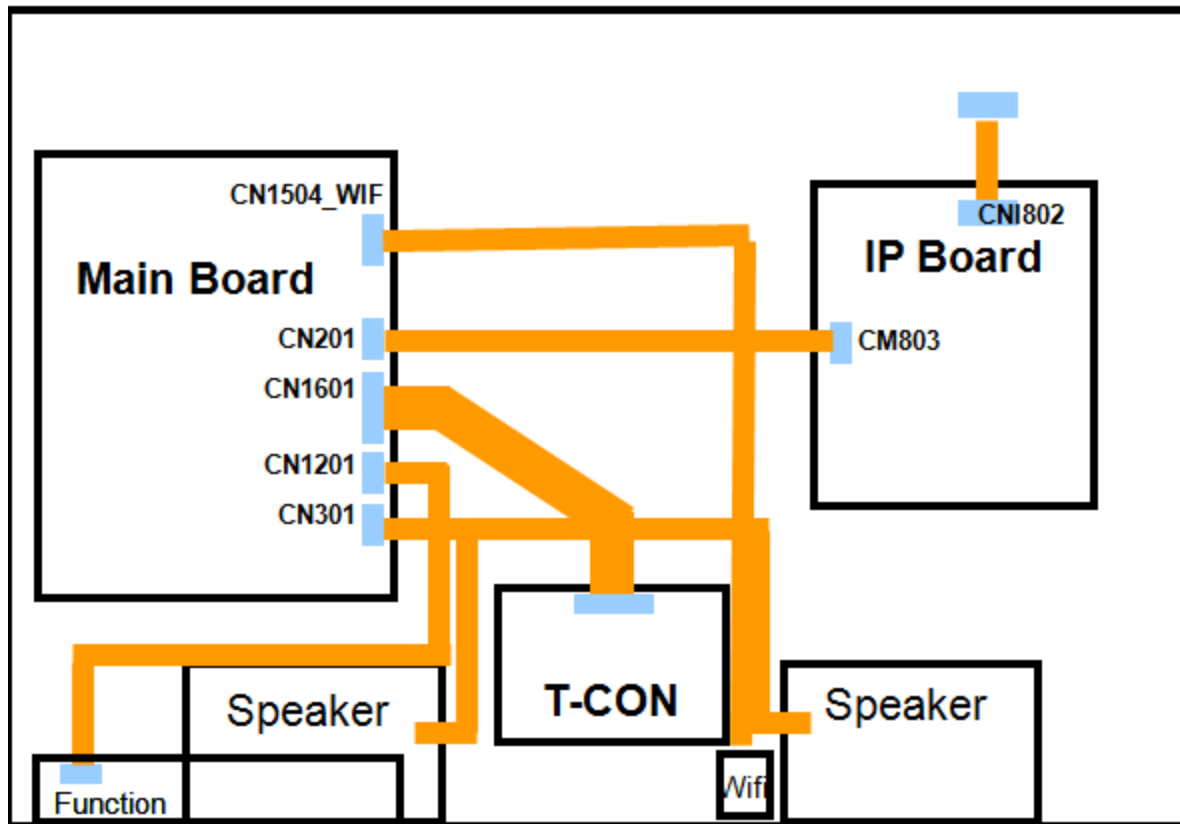

# Arsenal / Valencia Block Diagram

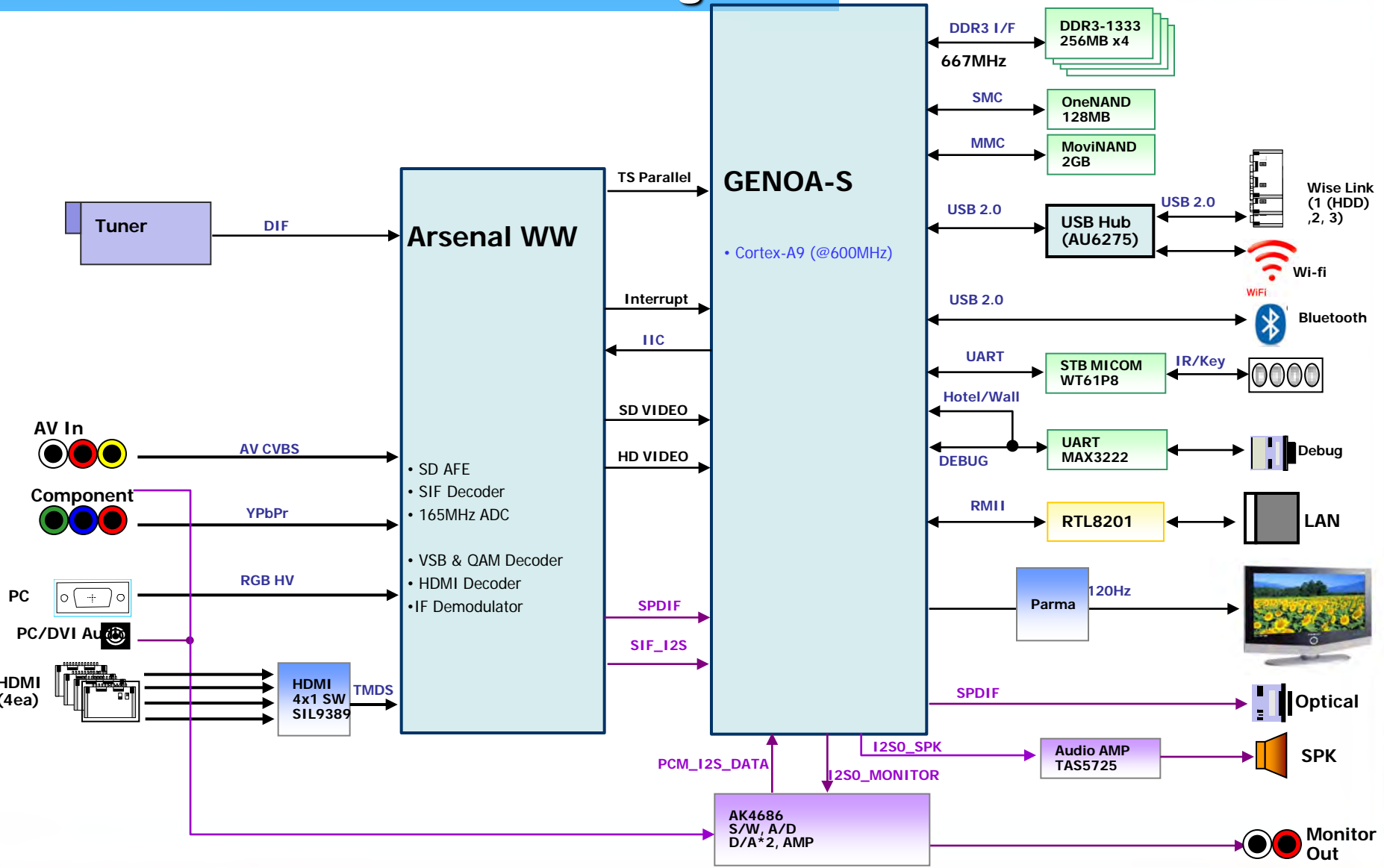

# Arsenal WW Internal Block Diagram

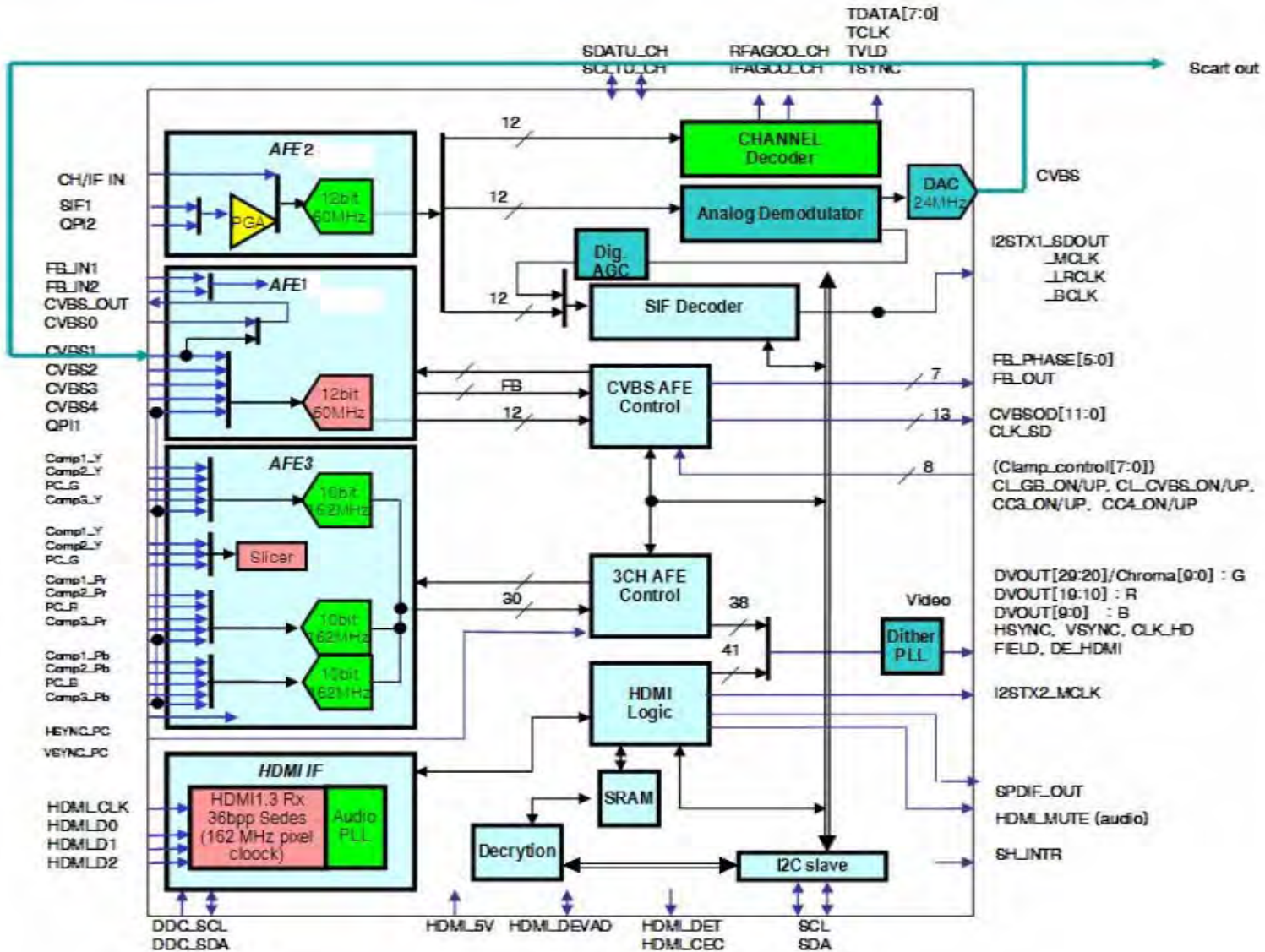



# GenoaS Internal Block Diagram

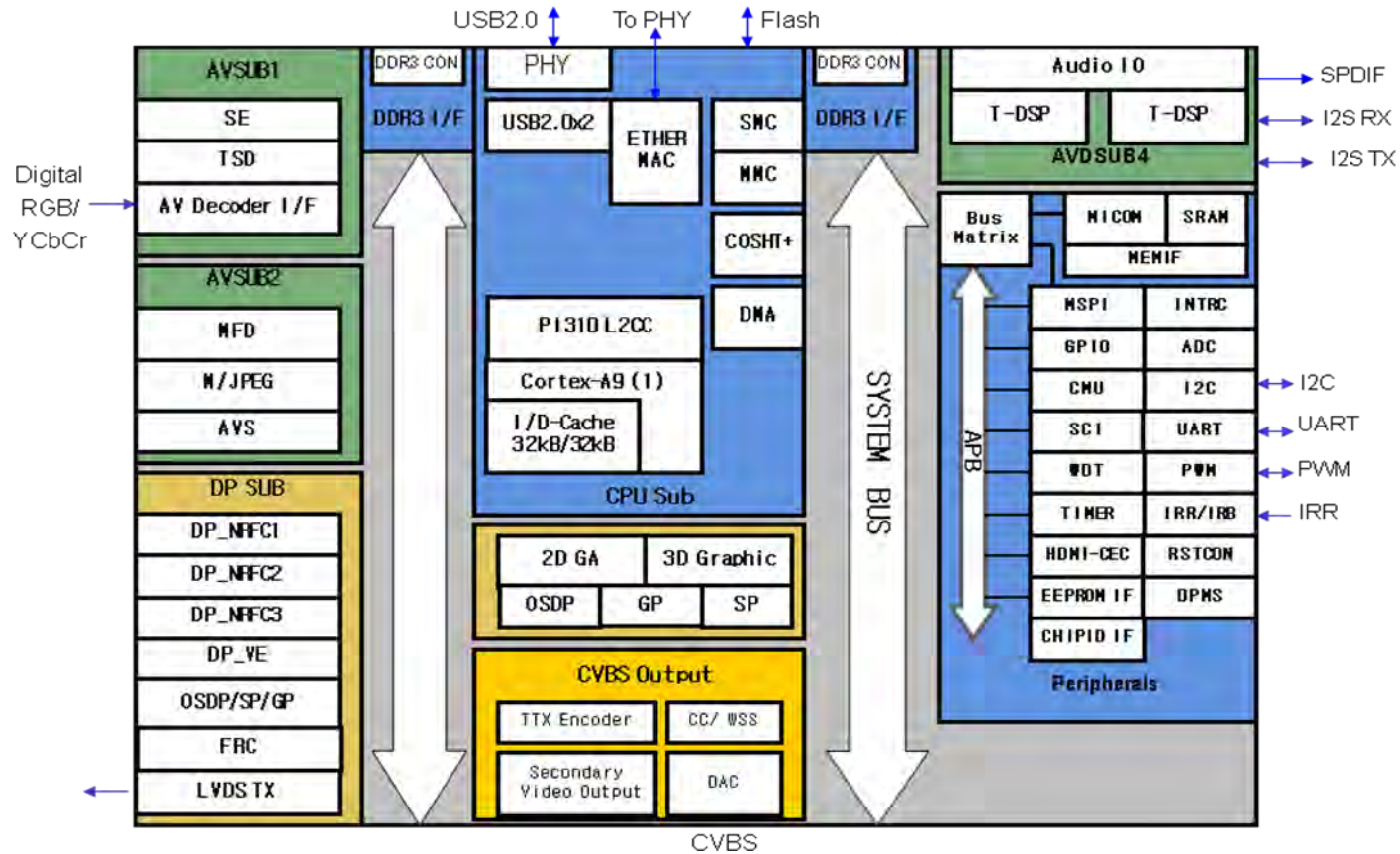

# Video Input path

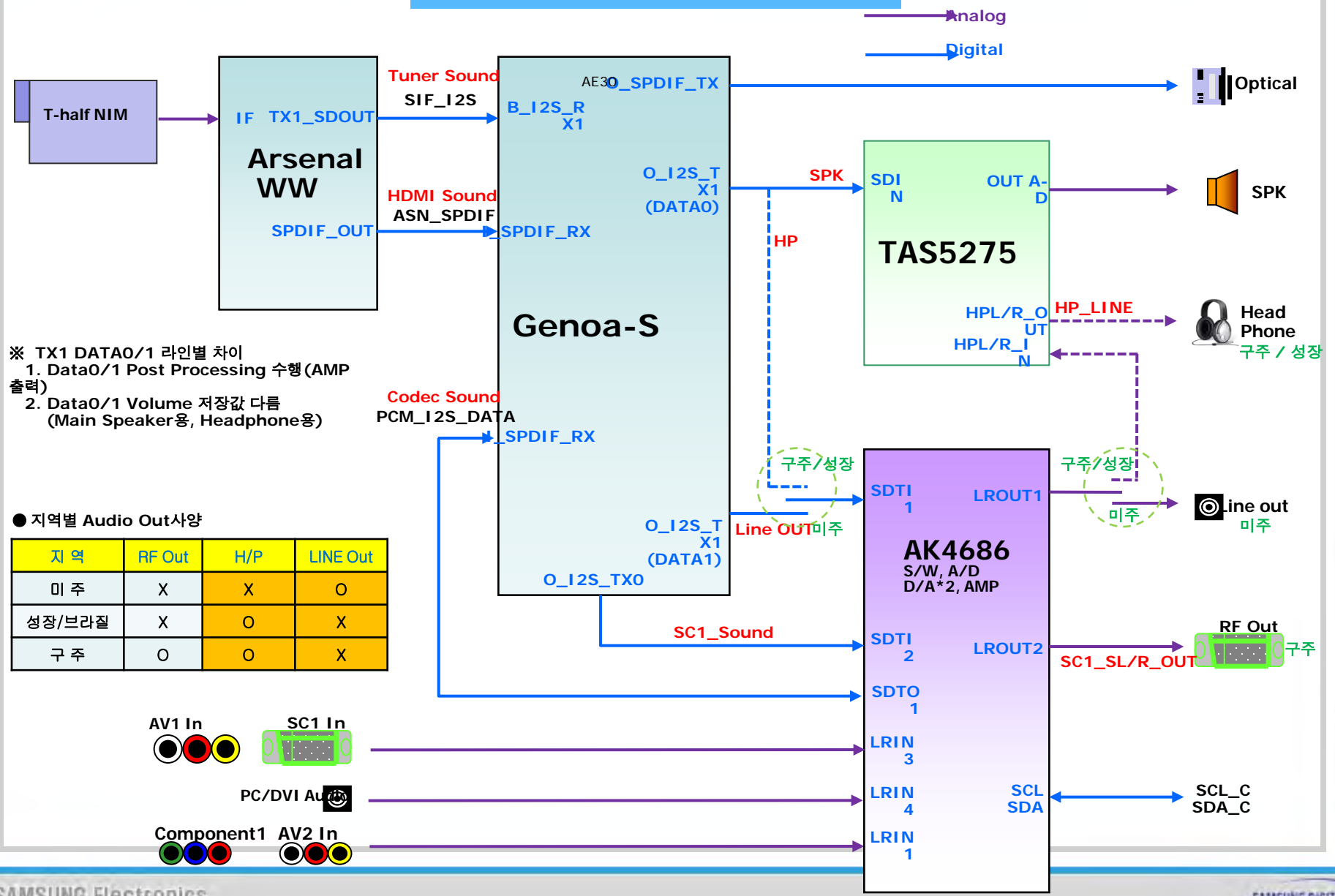

※ TX1 DATA0/1 라인별 차이  
 1. Data0/1 Post Processing 수행 (AMP 출력)  
 2. Data0/1 Volume 저장값 다름 (Main Speaker용, Headphone용)

● 지역별 Audio Out 사양

지역	RF Out	H/P	LINE Out
미주	X	X	O
성장/브라질	X	O	X
구주	O	O	X

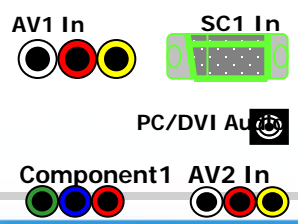

# Reset Tree

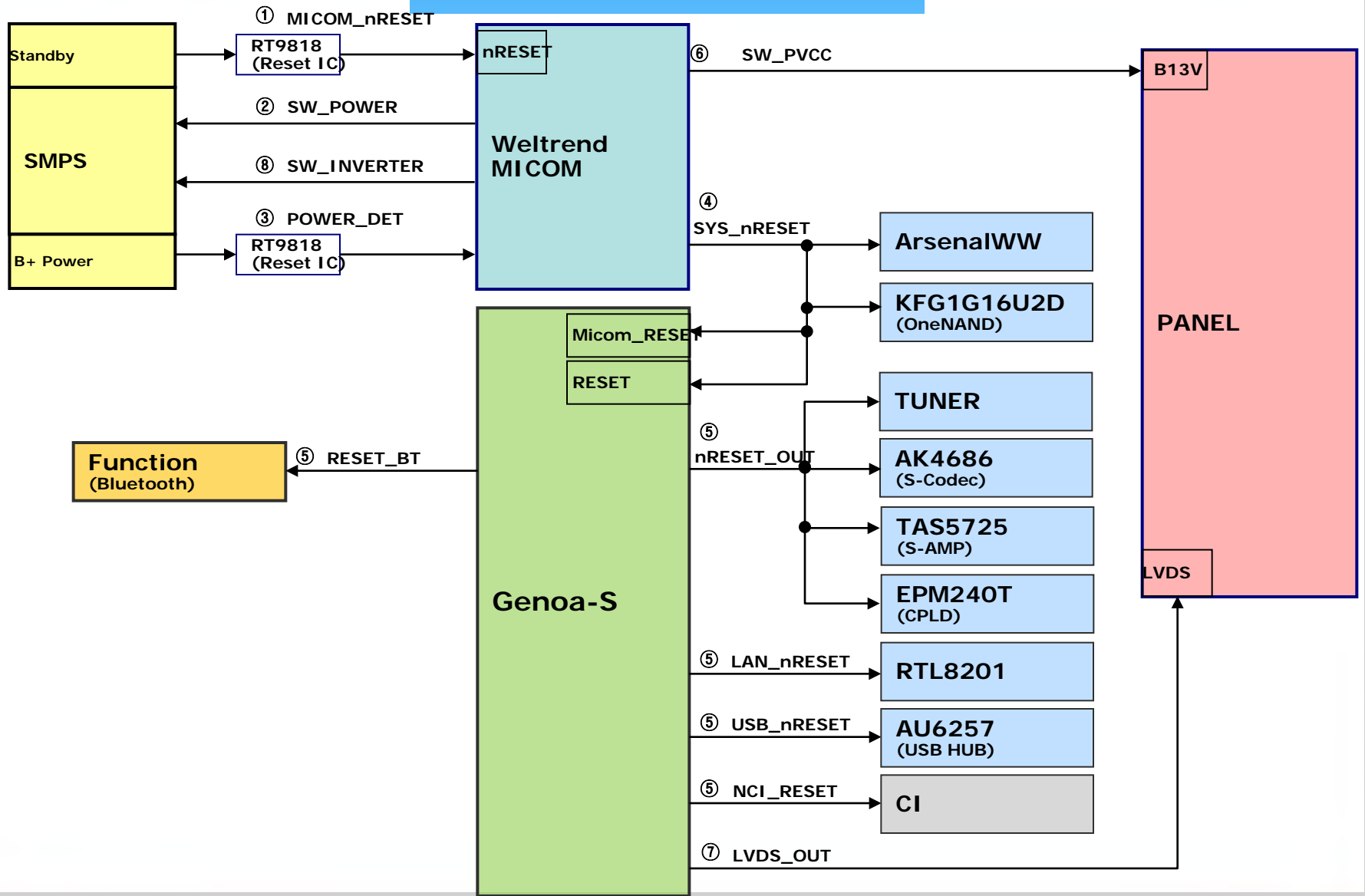

# I2C

**Genoa-S**

I2C0\_CLK  
I2C0\_DAT  
I2C0\_AT

I2C1\_CLK  
I2C1\_DAT  
I2C1\_AT

I2C2\_CLK  
I2C2\_DAT  
(CS2,3공용핀)

I2C3\_CLK  
I2C3\_DAT  
(GPIO0,1공용핀)

Internal MICOM

MI2C0\_CLK  
MI2C0\_DAT

MI2C1\_CLK  
MI2C1\_DAT

MI2C2\_CLK  
MI2C2\_DAT

MSPI / I2C

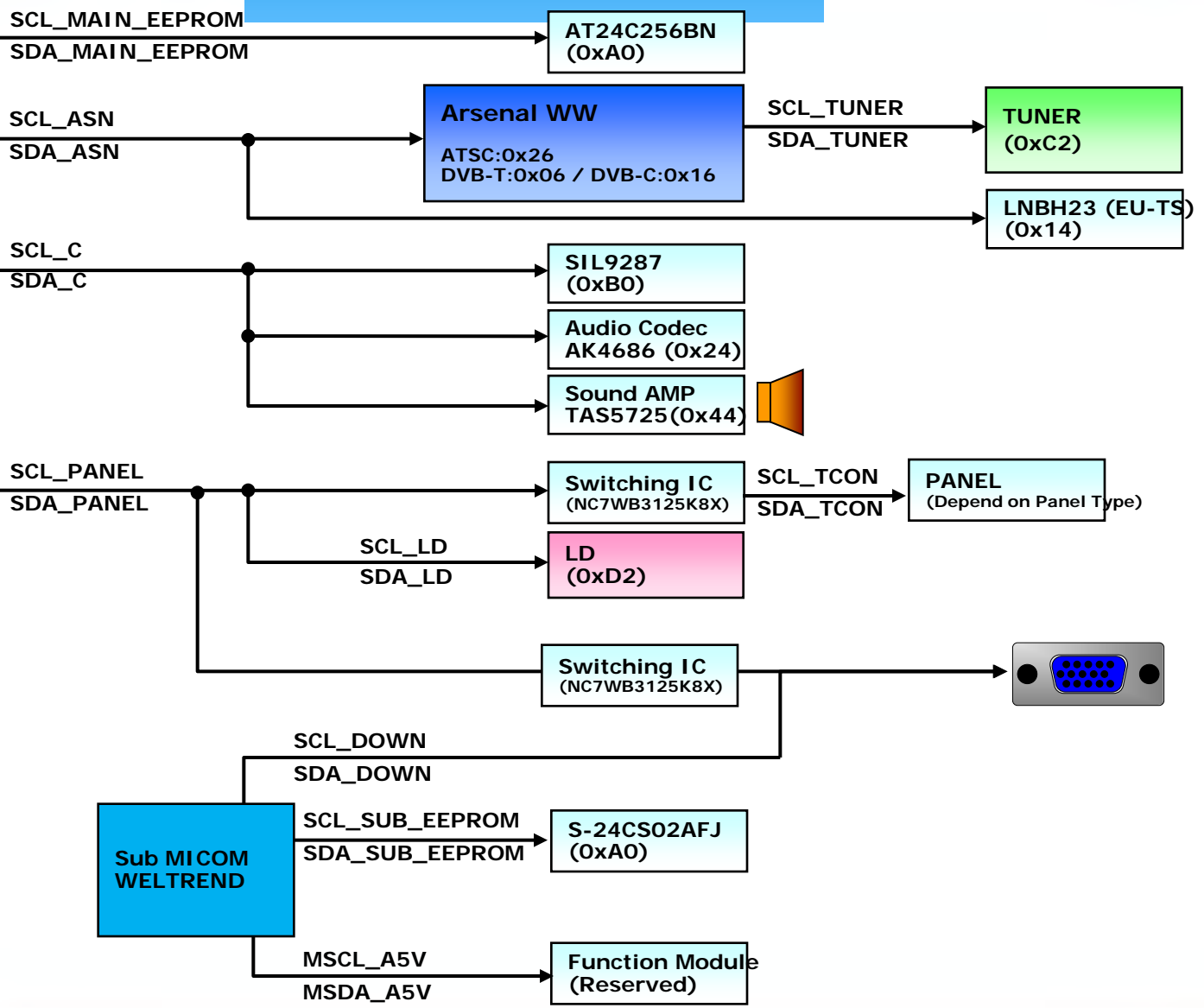

# UART

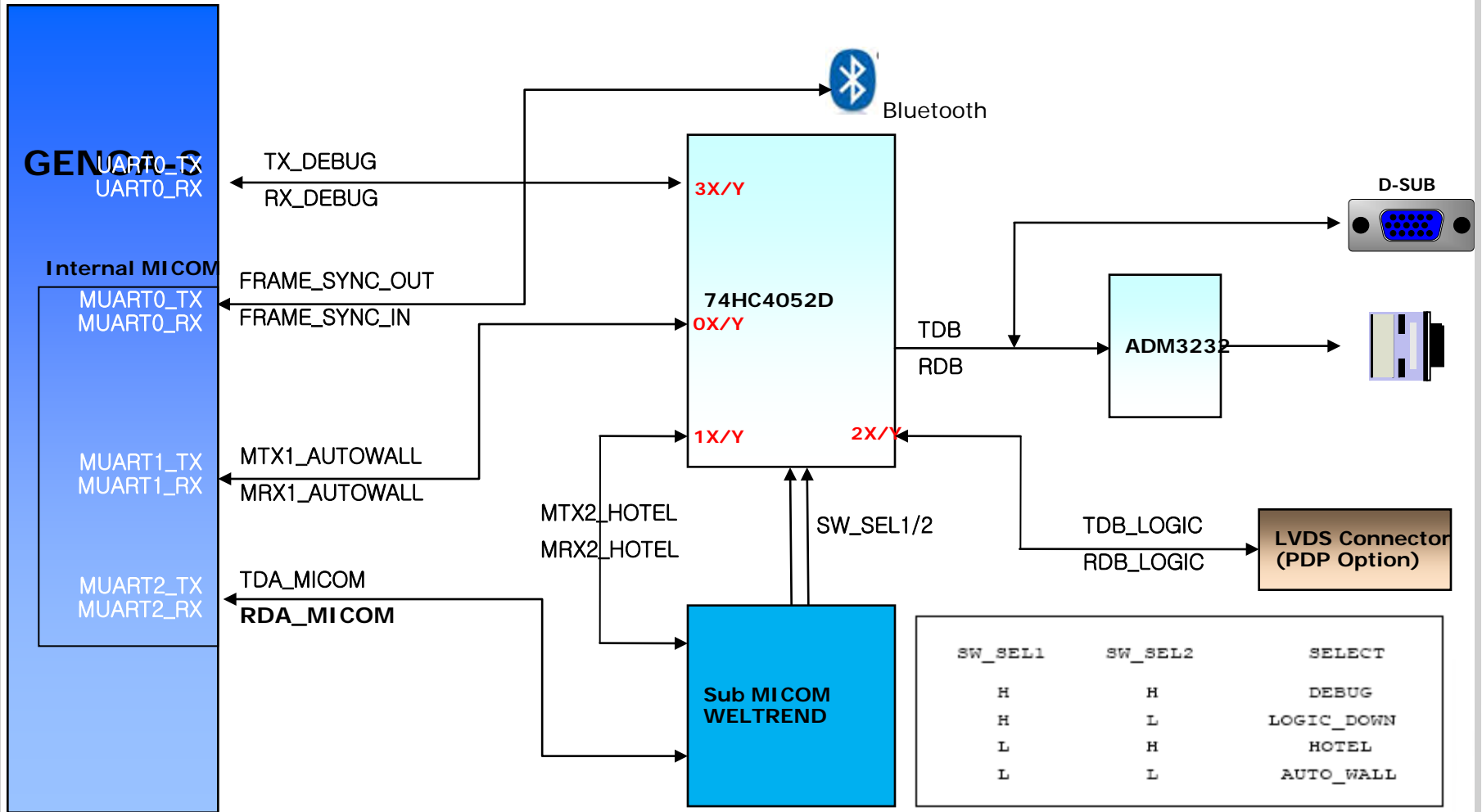

# Power Tree

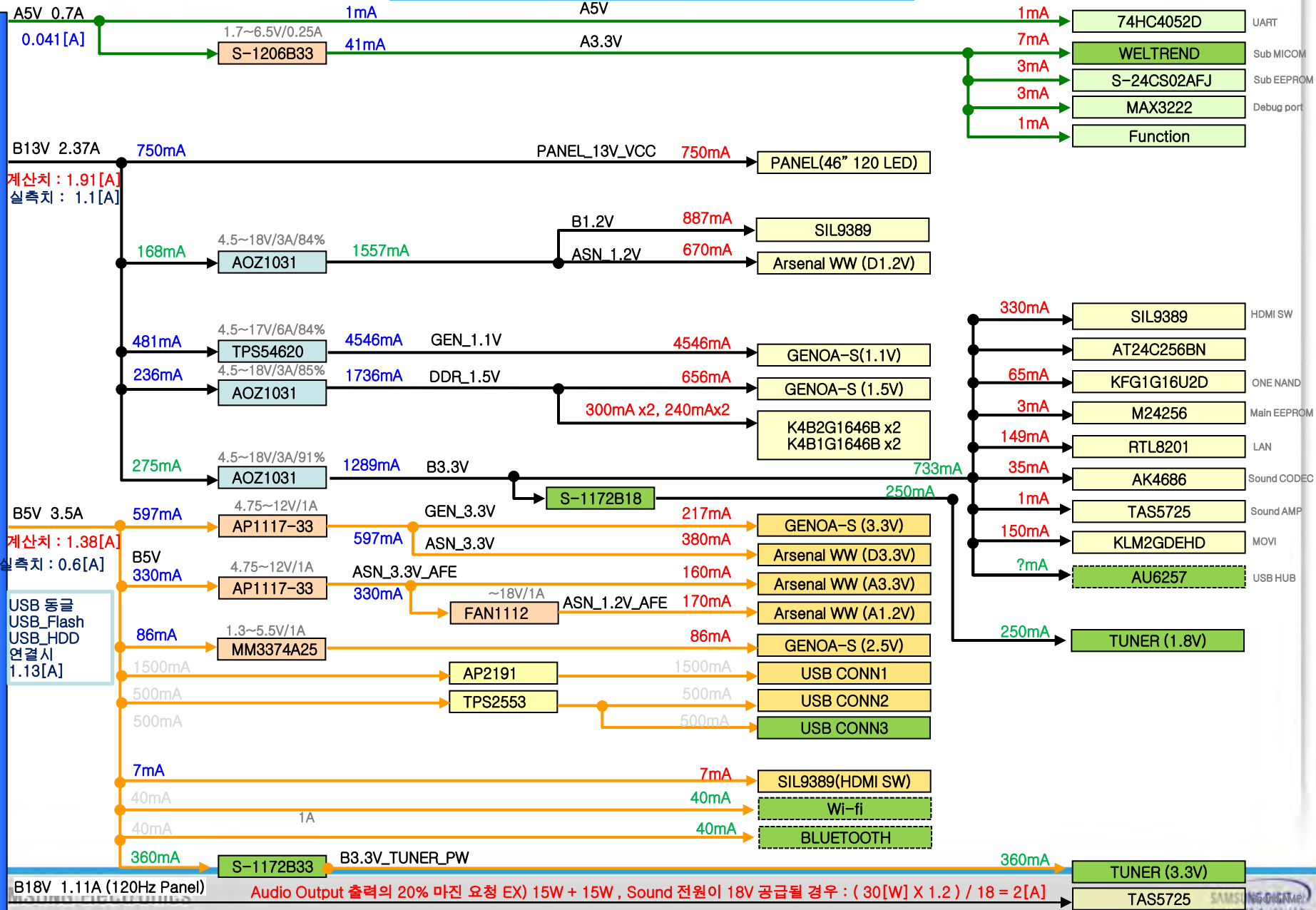

# Reset Timing Sequence

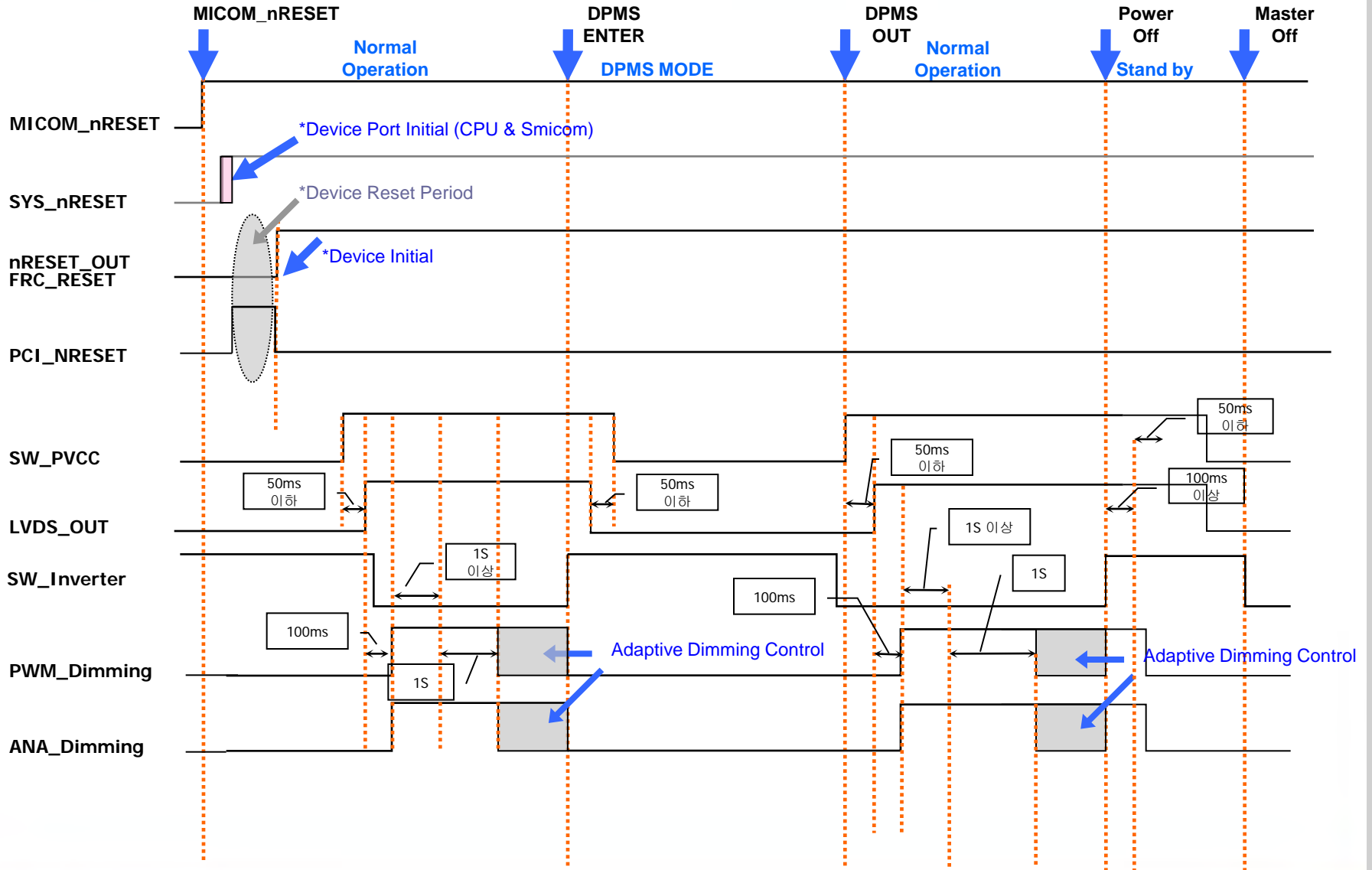



# New Function of UD6V

SAMSUNG

## Auto Motion Plus 120Hz

Removes drag from fast scenes with a lot of movement to provide a clearer picture.

Function (OSD)	120Hz FRC	Judder reduction (only 24p source)	Blur reduction
Off	Off (repeat)	Off	Off
Clear	ON (interpolation)	Off	High
Standard	ON (interpolation)	Medium	Medium
Smooth	ON (interpolation)	High	High
Custom	Level variable (0~10)		
Demo	Demo (Standard/off)		

\* If you enable Auto Motion Plus 120Hz, noise may appear on the screen. If this occurs, set Auto Motion Plus 120Hz to Off.

# Dolby Digital Plus

## Software Differences Between Dolby Digital and Dolby Digital Plus

	Dolby Digital	Dolby Digital Plus
Channels	1.0 to 5.1 discrete	1.0 to 13.1 discrete
Data rate	96–640 kbps	30 kbps–6 Mbps
Discrete sounds	Yes	Yes
Metadata parameters (dialogue normalization, dynamic range, downmixing)	Yes	Yes
Connection	S/PDIF or Toslink	IEEE 1394 HDMI™
Mixing/Streaming capabilities	No	Yes
Backward compatibility	Yes—analog output to Dolby Surround A/V receivers	Yes—S/PDIF to legacy A/V receivers
Availability	Current	Late 2005

# Media Play(USB & DLNA)

## Media Paly\_USB



This function enables you to view and listen to photo(JPEG), audio files(MP3) and movie (MPEG) saved on a USB Mass Storage Class (MSC) device.

# Media Play(USB & DLNA)

## Media Paly\_DLNA

Connectivity > DLNA



You can connect DLNA to your TV after setting up a network in your house.

You must install DLNA software on your PC in order to share stored content on your TV.

# Media Play(USB & DLNA)

## Supported Format vs. '08

Image Category			08 model	09 model
Wireless Ready			X	0
Seek function			X	0
Sub_Title			SMI	SMI,SRT,SUB,TXT,TTXT
Supported Format	Image	Progressive JPEG	X	0
	Audio		Same	
	Video			
			5 File extension	over 9 File extension

## '08 Video format

File Extension	Container	Video Decoder	Resolution	Audio codec
*.avi	AVI	Xvid	800x600	PCM
		H.264 MP	1920 X 1088	AC3
		MPEG4 SP	800 X 600	PCM
		MPEG4 ASP	800 X 600	ADPCM
		LMPEG	800 X 600	PCM
*.mp4	MP4	H.264 BP	1920 X 1088	AAC
		H.264 MP	1920 X 1088	PCM
*.mpg	P6	MPEG2	1920 X 1088	AC3
*.vob, *.vob	VRO	MPEG2	1920 X 1088	AC3



## '09 Video format

File Extension	Container	Video Decoder	Audio codec	Resolution	Frame/sec	MBR/sec	Comments
*.avi	AVI	DNx 5.1 I	H.264 ASP (H.264 MP)	500-600	6 ~ 30	5	HD ready
		DNx 4.x		500-600	6 ~ 30	5	HD ready
		DNx 5.1		500-600	6 ~ 30	5	HD ready
		DNx 6.0		1920x1080	6 ~ 30	20	HD ready
		XvD		1920x1080	6 ~ 30	20	HD ready, GHIO 1-Wrapping Point support
		H.264 BP		1920x1080	6 ~ 30	25	HD ready, GHIO 1-Wrapping Point support
		H.264 MP		1920x1080	6 ~ 30	25	HD ready, GHIO 1-Wrapping Point support
		H.264 HP		1920x1080	6 ~ 30	25	HD ready, GHIO 1-Wrapping Point support
		MPEG-4 SP		500-600	6 ~ 30	5	Same as DNX 4.x
		MPEG-4 ASP		500-600	6 ~ 30	5	GHIO 1-Wrapping Point support
*.mkv	MKV	Hottos JPEG	H.264 ASP (H.264 MP)	500-600	6 ~ 30	5	Teletext H.264 supported
		DNx 5.1 I		500-600	6 ~ 30	5	HD ready
		DNx 4.x		500-600	6 ~ 30	5	HD ready
		DNx 5.1		500-600	6 ~ 30	5	HD ready
		DNx 6.0		1920x1080	6 ~ 30	20	HD ready
		XvD		1920x1080	6 ~ 30	20	HD ready, GHIO 1-Wrapping Point support
		H.264 BP		1920x1080	6 ~ 30	25	HD ready, GHIO 1-Wrapping Point support
		H.264 MP		1920x1080	6 ~ 30	25	HD ready, GHIO 1-Wrapping Point support
		H.264 HP		1920x1080	6 ~ 30	25	HD ready, GHIO 1-Wrapping Point support
		MPEG-4 SP		500-600	6 ~ 30	5	Same as DNX 4.x
*.asf	ASF	MPEG-4 ASP	H.264 ASP (H.264 MP)	500-600	6 ~ 30	5	GHIO 1-Wrapping Point support
		Hottos JPEG		500-600	6 ~ 30	5	Teletext H.264 supported
		DNx 5.1 I		500-600	6 ~ 30	5	HD ready
		DNx 4.x		500-600	6 ~ 30	5	HD ready
		DNx 5.1		500-600	6 ~ 30	5	HD ready
		DNx 6.0		1920x1080	6 ~ 30	20	HD ready
		XvD		1920x1080	6 ~ 30	20	HD ready, GHIO 1-Wrapping Point support
		H.264 BP		1920x1080	6 ~ 30	25	HD ready, GHIO 1-Wrapping Point support
		H.264 MP		1920x1080	6 ~ 30	25	HD ready, GHIO 1-Wrapping Point support
		H.264 HP		1920x1080	6 ~ 30	25	HD ready, GHIO 1-Wrapping Point support
*.wmv (VCI)	Window Media Video v9	MPEG-4 ASP	H.264 ASP (H.264 MP)	500-600	6 ~ 30	5	Same as DNX 4.x
		Hottos JPEG		500-600	6 ~ 30	5	Teletext H.264 supported
		DNx 5.1 I		500-600	6 ~ 30	5	HD ready
		DNx 4.x		500-600	6 ~ 30	5	HD ready
		DNx 5.1		500-600	6 ~ 30	5	HD ready
		DNx 6.0		1920x1080	6 ~ 30	20	HD ready
		XvD		1920x1080	6 ~ 30	20	HD ready, GHIO 1-Wrapping Point support
		H.264 BP		1920x1080	6 ~ 30	25	HD ready, GHIO 1-Wrapping Point support
		H.264 MP		1920x1080	6 ~ 30	25	HD ready, GHIO 1-Wrapping Point support
		H.264 HP		1920x1080	6 ~ 30	25	HD ready, GHIO 1-Wrapping Point support
*.mp4 (H.264)	H.264 MP	MPEG-4 SP	H.264 ASP (H.264 MP)	500-600	6 ~ 30	5	Same as DNX 4.x
		MPEG-4 ASP		500-600	6 ~ 30	5	GHIO 1-Wrapping Point support
		Hottos JPEG		500-600	6 ~ 30	5	Teletext H.264 supported
		DNx 5.1 I		500-600	6 ~ 30	5	HD ready
		DNx 4.x		500-600	6 ~ 30	5	HD ready
		DNx 5.1		500-600	6 ~ 30	5	HD ready
		DNx 6.0		1920x1080	6 ~ 30	20	HD ready
		XvD		1920x1080	6 ~ 30	20	HD ready, GHIO 1-Wrapping Point support
		H.264 BP		1920x1080	6 ~ 30	25	HD ready, GHIO 1-Wrapping Point support
		H.264 MP		1920x1080	6 ~ 30	25	HD ready, GHIO 1-Wrapping Point support
*.h264	H.264 MP	MPEG-4 SP	H.264 ASP (H.264 MP)	500-600	6 ~ 30	5	Same as DNX 4.x
		MPEG-4 ASP		500-600	6 ~ 30	5	GHIO 1-Wrapping Point support
		Hottos JPEG		500-600	6 ~ 30	5	Teletext H.264 supported
		DNx 5.1 I		500-600	6 ~ 30	5	HD ready
		DNx 4.x		500-600	6 ~ 30	5	HD ready
		DNx 5.1		500-600	6 ~ 30	5	HD ready
		DNx 6.0		1920x1080	6 ~ 30	20	HD ready
		XvD		1920x1080	6 ~ 30	20	HD ready, GHIO 1-Wrapping Point support
		H.264 BP		1920x1080	6 ~ 30	25	HD ready, GHIO 1-Wrapping Point support
		H.264 MP		1920x1080	6 ~ 30	25	HD ready, GHIO 1-Wrapping Point support

• There are some technical differences between USB(local play) and DLNA(network play).

So DLNA may have some limitations of functions such as play, seek, jump in unusual case.



# internet@TV

## Screen Display

You can search for various types of content that can be used on your TV. Enter a keyword to search for media, various applications, or online information that you can use on the TV.

TV Screen: Displays the current input source screen..



Information: Displays notices, new applications, and advertisements brought to you by Samsung product introductions.

### Controls:

- **Red (Login):** To log in to **Smart Hub** .
  - **Green (Sorting):** To sort the applications by category.
  - **Yellow (Edit):** You can edit the applications (such as move, making folder).
  - **Blue (Settings):** Edit and configure applications and Smart Hub settings.
- ☑ The color buttons may work differently depending on the application.

Exit: Exits the SMART HUB.

Application service: You can experience various service by provided samsung.

Recommended Applications: Displays the recommended service by Samsung. You are not able to add or delete a service in this list.

Installed Applications list: Displays the installed applications in the TV.



# OTN



**User**

- automatic upgrade
- high speed downloading
- reliable upgrade

**Model A**



- Secure & safe upgrade
- Fault tolerancing

**Model B**



**Model C**



**Network server**

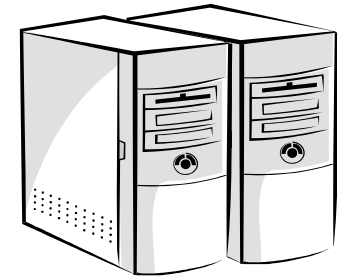

SW management

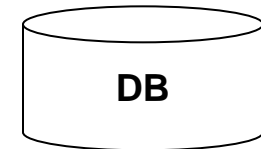

- Scalable service
- Secure & reliable

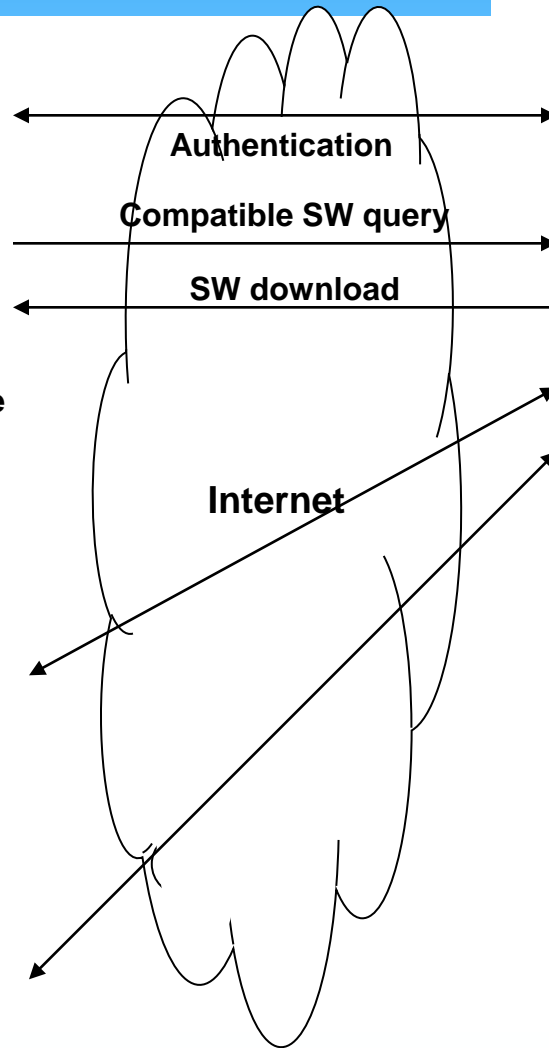

# OTN

## ■ Purpose of OTN

because of variable contents and devices, TV software will be more and more complicate. So it is necessary that TV software is updated real time.

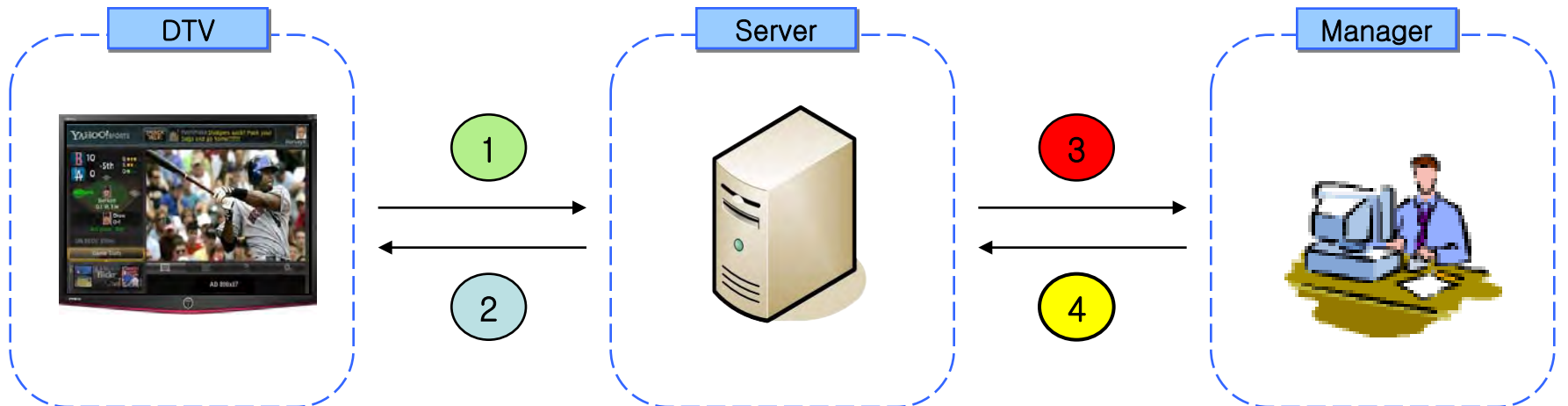

1

- 1. DTV registration info.
- 3. Installed S/W info.
- 7. Download info.
- 8. Install result / Error info.

2

- 2. Verify registration
- 4. Available S/W info.
- 5. Install S/W info.
- 6. S/W Image / Security key

3

- Install error info.
- Statistics info.
- Statistics of error info.

4

- Model info.
- Model S/W ver info.
- S/W release policy

# Home Network Center

- Home Network Applications that built in networking DTV.
- Message: TV display the message, phone call list, schedule of cell phone by network.

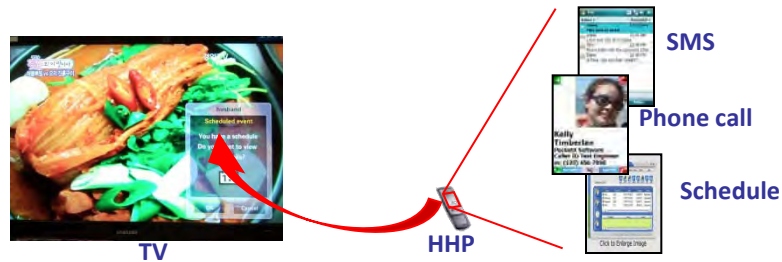

- Media: TV play the movie, picture, music that stored in cell phone by network.

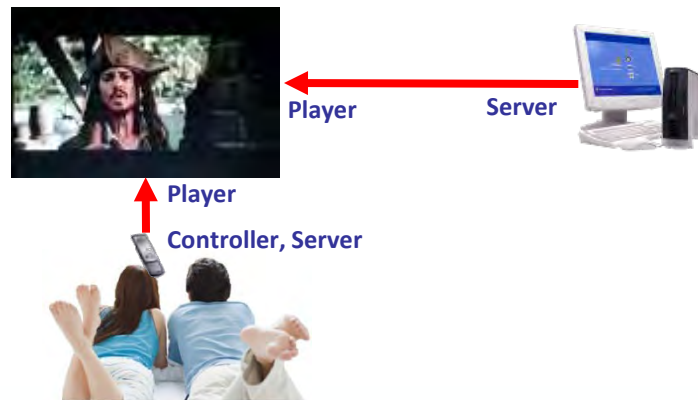

## Supported PC timing

### ■ D-Sub and HDMI/DVI Input

☑ When using an HDMI/DVI cable connection, you must use the **HDMI IN 1** jack.

Mode	Resolution	Horizontal Frequency (kHz)	Vertical Frequency (Hz)	Pixel Clock Frequency (MHz)	Sync Polarity (H / V)
IBM	720 x 400	31.469	70.087	28.322	- / +
MAC	640 x 480	35.000	66.667	30.240	- / -
	832 x 624	49.726	74.551	57.284	- / -
	1152 x 870	68.681	75.062	100.000	- / -
VESA	640 x 480	31.469	59.940	25.175	- / -
	640 x 480	37.861	72.809	31.500	- / -
	640 x 480	37.500	75.000	31.500	- / -
	800 x 600	37.879	60.317	40.000	+ / +
	800 x 600	48.077	72.188	50.000	+ / +
	800 x 600	46.875	75.000	49.500	+ / +
	1024 x 768	48.363	60.004	65.000	- / -
	1024 x 768	56.476	70.069	75.000	- / -
	1024 x 768	60.023	75.029	78.750	+ / +
1152 x 864	67.500	75.000	108.000	+ / +	



## Supported PC timing

Mode	Resolution	Horizontal Frequency (kHz)	Vertical Frequency (Hz)	Pixel Clock Frequency (MHz)	Sync Polarity (H / V)
	1280 x 800	49.702	59.810	83.500	- / +
	1280 x 960	60.000	60.000	108.000	+ / +
	1280 x 1024	63.981	60.020	108.000	+ / +
	1280 x 1024	79.976	75.025	135.000	+ / +
	1360 x 768	47.712	60.015	85.500	+ / +
	1440 x 900	55.935	59.887	106.500	- / +
	1440 x 900	70.635	74.984	136.750	- / +
	1680 x 1050	65.290	59.954	146.250	- / +
	1920 x 1080p	67.500	60.000	148.500	+ / +
CEA	1920 x 1080p	67.500	60.000	148.500	+ / +

## PIP/POP Table

### Amber(08')

Main \ sub	Analog TV	Digital TV
HDMI	O	X
COMP	O	X
PC	O	X
Select sound (Main/Sub)	X	



### LC6400(09'/10')

Main \ sub	Analog TV	Digital TV
HDMI	O	O
COMP	O	O
PC	O	O
Select sound (Main/Sub)	O	

**\* PIP support**

- You can view PIP screen when the main picture is HDMI 1,2,3,4, Component 1,2 or PC

## HDMI/DVI edit name

Amber(08')

HDMI 2/DVI

Edit Name	Sound Input	Picture mode
PC	Auto	PC setting



LC6400(09'/10')

HDMI 1/DVI













Edit Name	Sound Input	Picture mode
PC	Auto	PC setting
DM	DM R/L	Normal setting
DM PC	DM R/L	PC setting

\* Auto : System judge that source type automatically, and select sound input(HDMI /DVI).









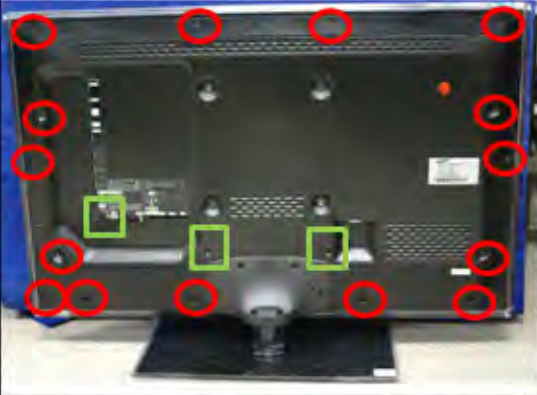

## Disassembly of LB6T

Description	Picture Description	Screws													
<p>1. Remove screws from the Stand. Remove stand.</p> <p>* Screw size used in manual</p>	 														
<table border="1" data-bbox="363 496 716 1039"> <tr> <td data-bbox="363 496 537 654">  </td> <td data-bbox="537 496 716 654">  </td> </tr> <tr> <td data-bbox="363 654 537 768">                     6001-002621 SCREW-MACHINE M4,L8 BLK                 </td> <td data-bbox="537 654 716 768">                     6001-002671 SCREW-MACHINE M3,L6 BLK                 </td> </tr> <tr> <td colspan="2" data-bbox="537 768 716 925">  </td> </tr> <tr> <td colspan="2" data-bbox="537 925 716 1039">                     6001-002653 SCREW-MACHINE M3,L6 WHT                 </td> </tr> </table>				6001-002621 SCREW-MACHINE M4,L8 BLK	6001-002671 SCREW-MACHINE M3,L6 BLK			6001-002653 SCREW-MACHINE M3,L6 WHT		<table border="1" data-bbox="1335 544 1561 1119"> <tr> <td data-bbox="1335 544 1561 586">6001-002621</td> </tr> <tr> <td data-bbox="1335 586 1561 629">SCREW-MACHINE</td> </tr> <tr> <td data-bbox="1335 629 1561 719">M4,L8 BLK</td> </tr> <tr> <td data-bbox="1335 719 1561 943"></td> </tr> <tr> <td data-bbox="1335 943 1561 1033"></td> </tr> <tr> <td data-bbox="1335 1033 1561 1119"></td> </tr> </table>	6001-002621	SCREW-MACHINE	M4,L8 BLK		
															
6001-002621 SCREW-MACHINE M4,L8 BLK	6001-002671 SCREW-MACHINE M3,L6 BLK														
															
6001-002653 SCREW-MACHINE M3,L6 WHT															
6001-002621															
SCREW-MACHINE															
M4,L8 BLK															

## Disassembly of LB6T

Description	Picture Description	Screws
<p>2. Remove the screws of rear-cover.</p>		 <p>6001-002671</p> <p>SCREW-MACHINE</p> <p>M3,L6 BLK</p>
<p>3. Lift up and remove the rear-cover.</p> <p>*Caution : Be careful when you lift up the rear-cover, it's really sharp</p>		

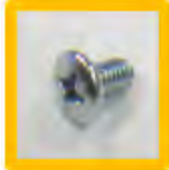
### Disassembly of LB6T

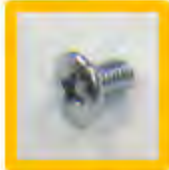

Description	Picture Description	Screws
<p>4. Remove the screws of main board.</p>		 <p>6001-002653</p> <p>SCREW-MACHINE</p> <p>M3,L6 WHT</p>
<p>* New type of LVDS conn. applied to 11 year model. (Double locking)</p> <ul style="list-style-type: none"> <li>① Up the first locking</li> <li>② Push the second locking and detach conn..</li> </ul>		

## Disassembly of LB6T



Description	Picture Description	Screws
<p>4-1. Remove the screws of IP board. Remove the IP board.</p>		 <p>6001-002653</p> <p>SCREW-MACHINE</p> <p>M3,L6 WHT</p>



## Disassembly of LB6T

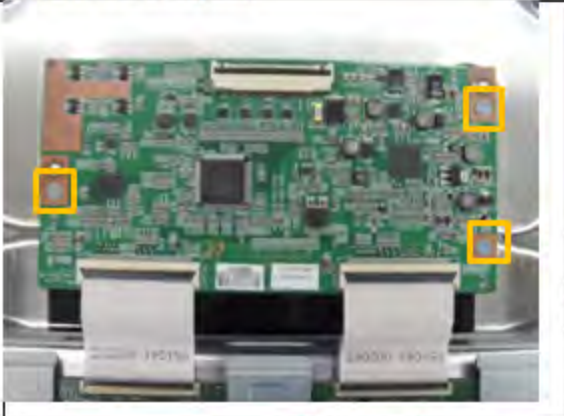

Description	Picture Description	Screws
5-1. Remove the cover-bottom		
6. Remove the screws of Stand-link BLKT, and remove Stand-link BLKT.		<div style="border: 2px solid yellow; padding: 5px; display: inline-block; margin-bottom: 10px;">  </div> <p>6001-002653</p> <p>SCREW-MACHINE</p> <p>M3,L6 WHT</p>

## Disassembly of LB6T

Description	Picture Description	Screws
<p>6. Remove the screws of T-con.</p>		 <p>6001-002653</p> <p>SCREW-MACHINE</p> <p>M3,L6 WHT</p>
<p>6-1. Unlock the locking of T-con cable.</p>		



## Disassembly of LB6T

Description	Picture Description	Screws
7-1. Panel.	 A photograph showing the rear side of the LB6T panel. It features a metal frame with various internal components, including a central display area, wiring (red, yellow, and black), and a small electronic module at the bottom center. The panel is mounted on a dark surface.	
7-2. Front	 A photograph showing the front side of the LB6T panel. It displays a large, rectangular, light-colored display area with a dark border. A thin, curved line is visible on the display surface. The panel is mounted on a dark surface.	

# Trouble Shooting



## Check List for Initial operation

- . Power cord in to the set
- . Power switch on
- . You can sound IP relay (not for 40")
  - \* If you can't sound, check the STB\_5V appear
- . Back-light on
  - \* If back-light doesn't on
    - > Check the backlight on, when 30p power cable is not connected.
- . Picture on or display the banner
  - \* If display is nothing, check the LVDS cable  
And LVDS clk/data line

## Inform to change the Assembly

- . Check the Side-Lable Ver. in set (important)
- . Order to the item with Side-Lable Ver.
- . If you change the item, see the service-bulletin for setting the factory option.

## Inform about error messages

- . If set is connected internet and software is old version , popup below message.

" version XXXXX is available, upgrade?"

- . And select OK, you can update your LCD TV.

# Trouble Shooting - No Power

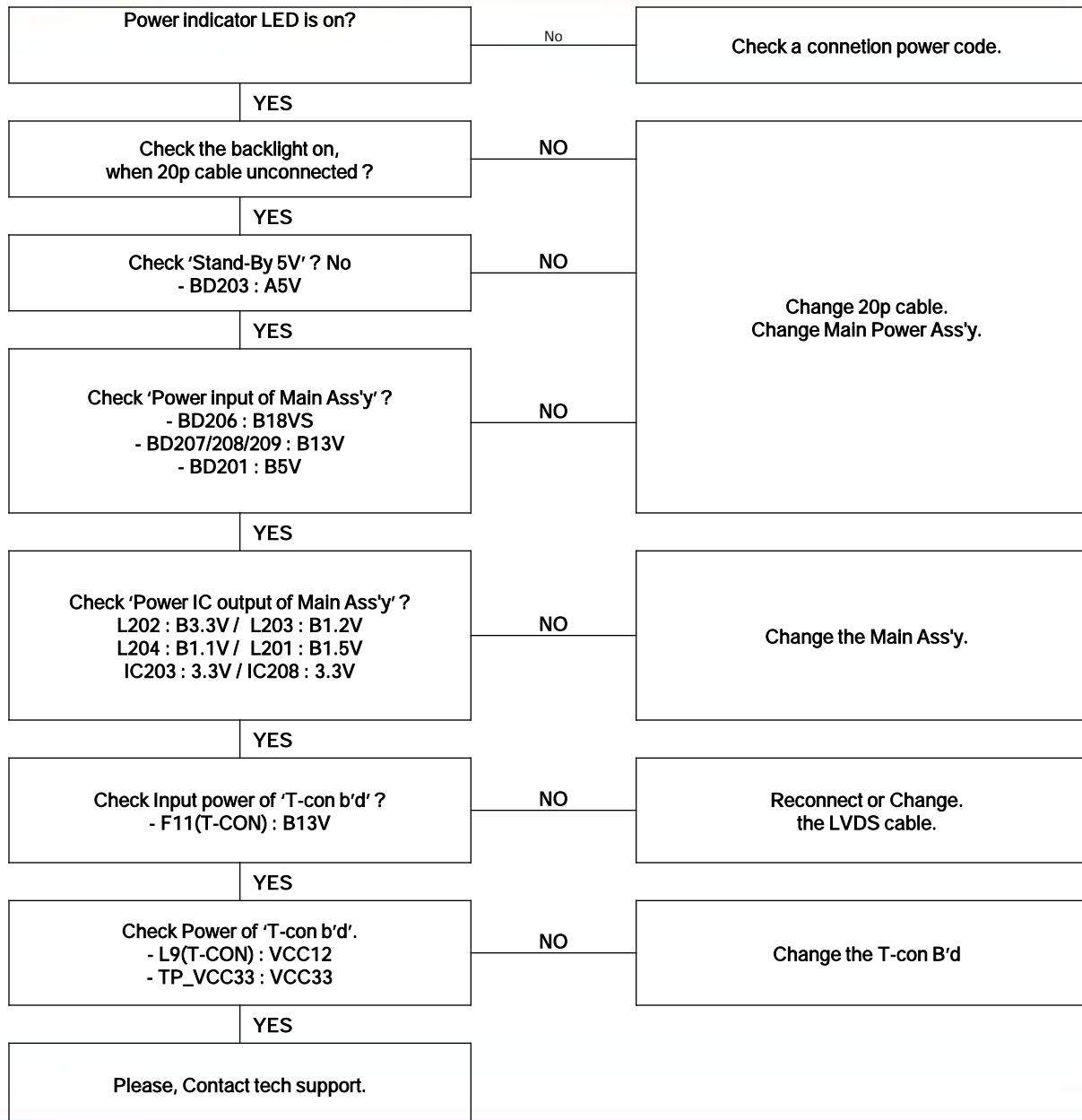

# Trouble Shooting – No Video (analog PC)

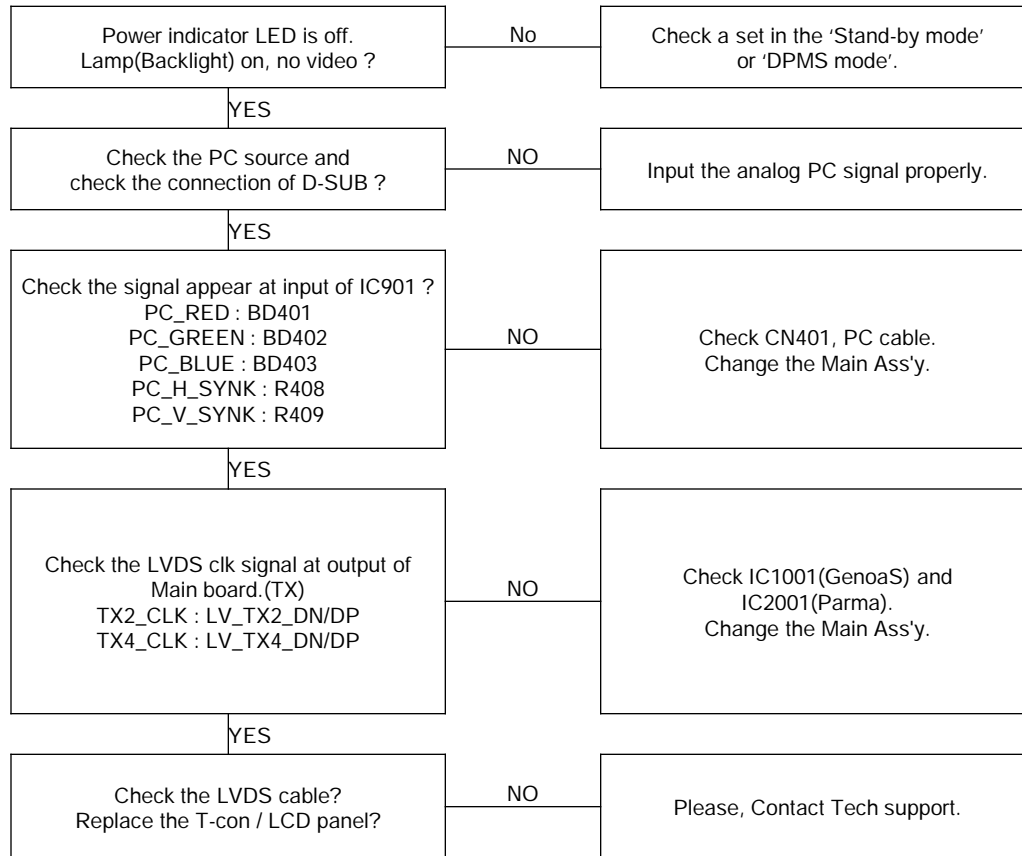



# Trouble Shooting – No Video (analog PC)

4

PC input (V-sink , H-sink , R/G/B )

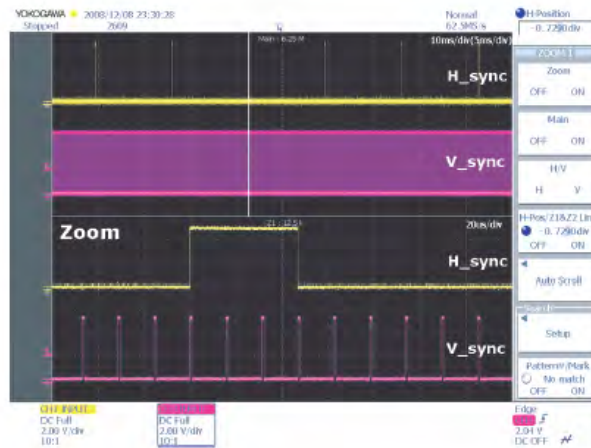

5

LVDS output

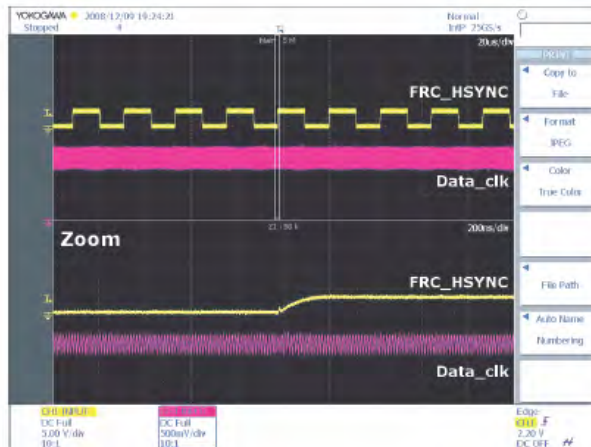

# Trouble Shooting – No Video (HDMI)

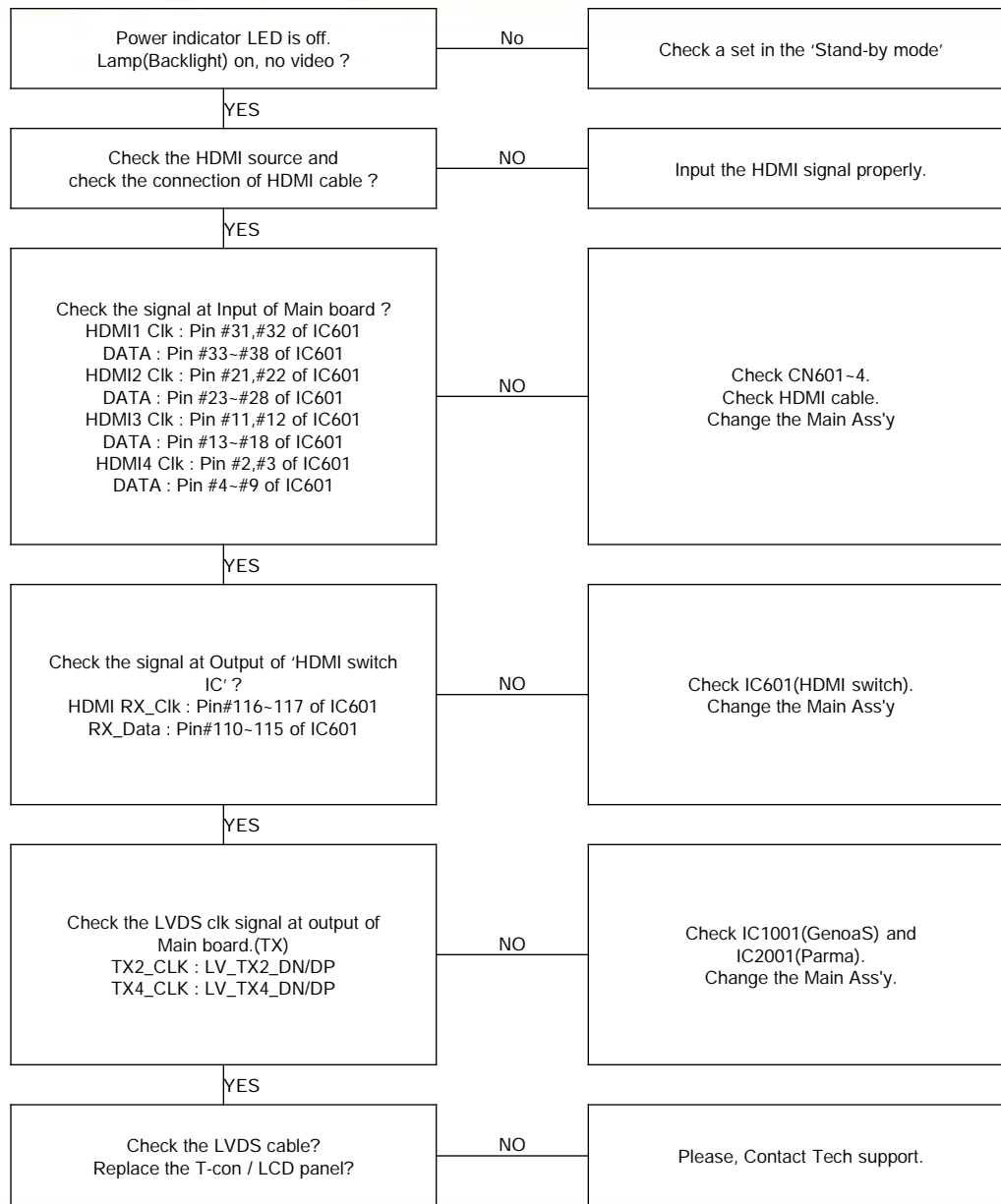

# Trouble Shooting – No Video (HDMI)

6

PC input (V-sink , H-sink , R/G/B )

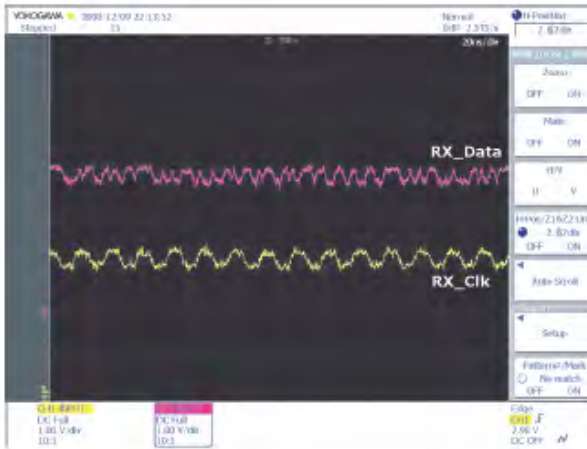

5

LVDS output

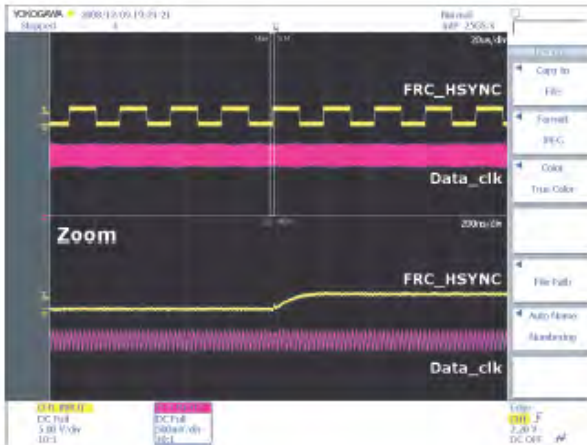

# Trouble Shooting – No Video (Tuner CVBS)

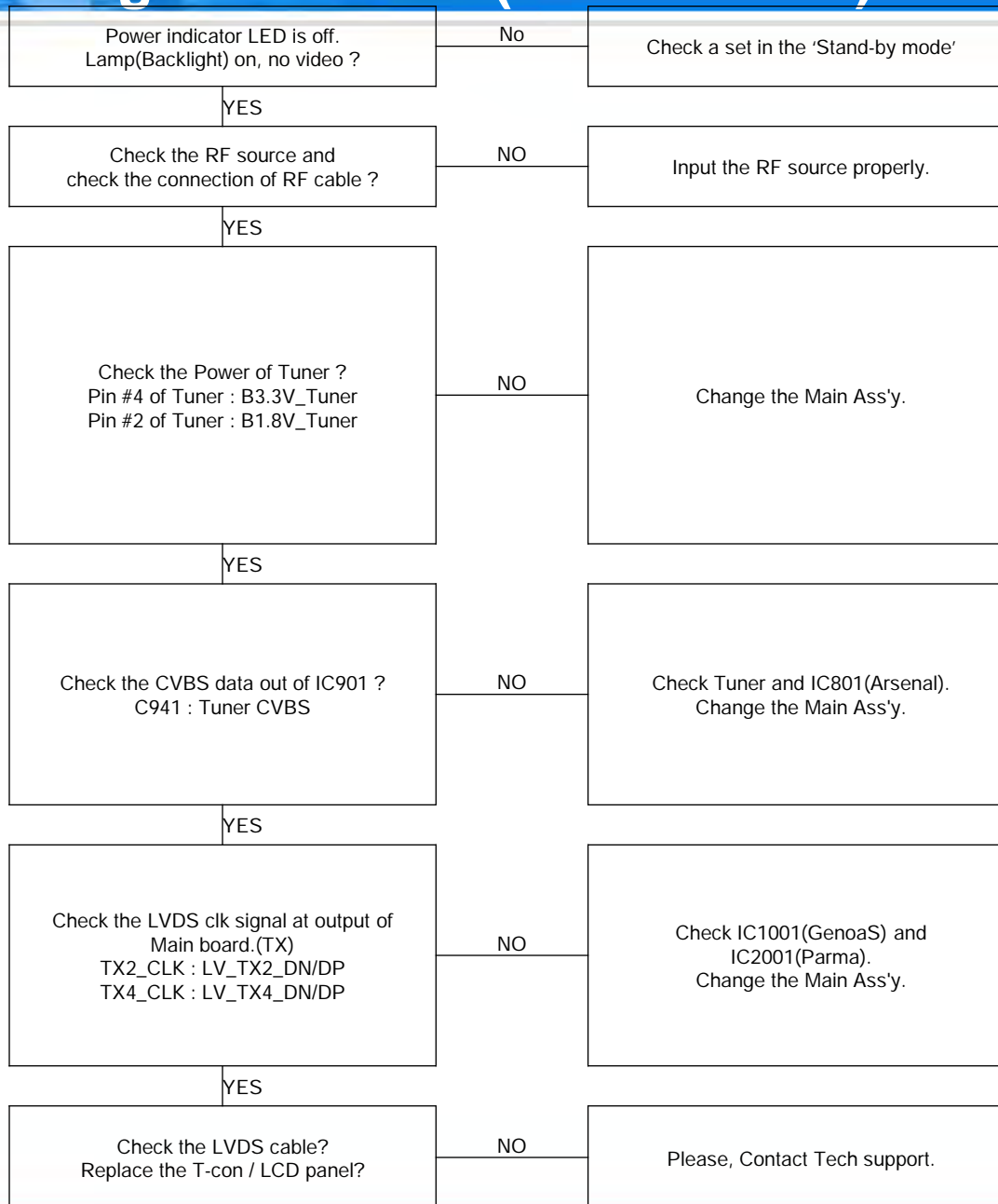

# Trouble Shooting – No Video (Tuner CVBS)

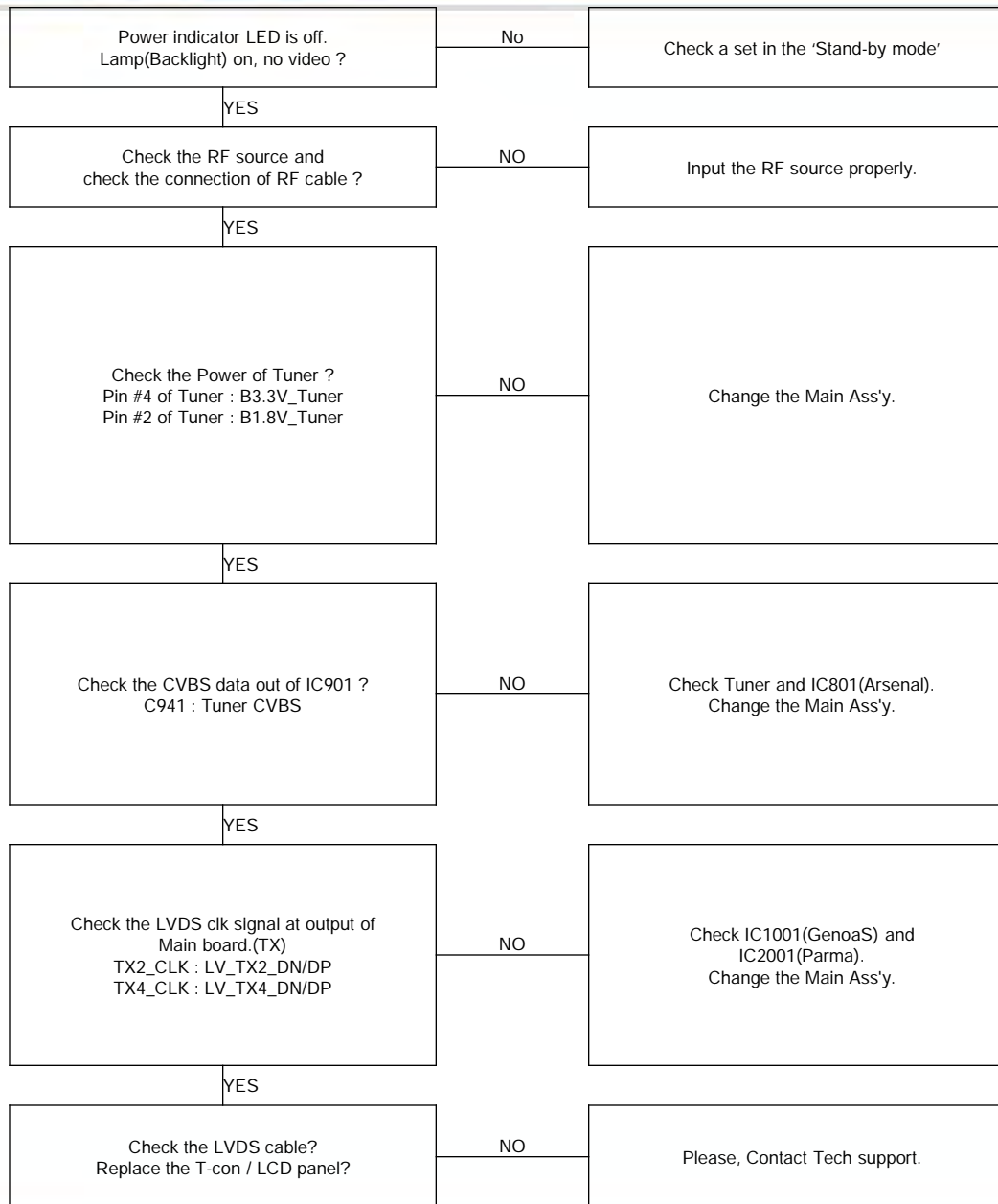

# Trouble Shooting - No Video (Tuner DTV)

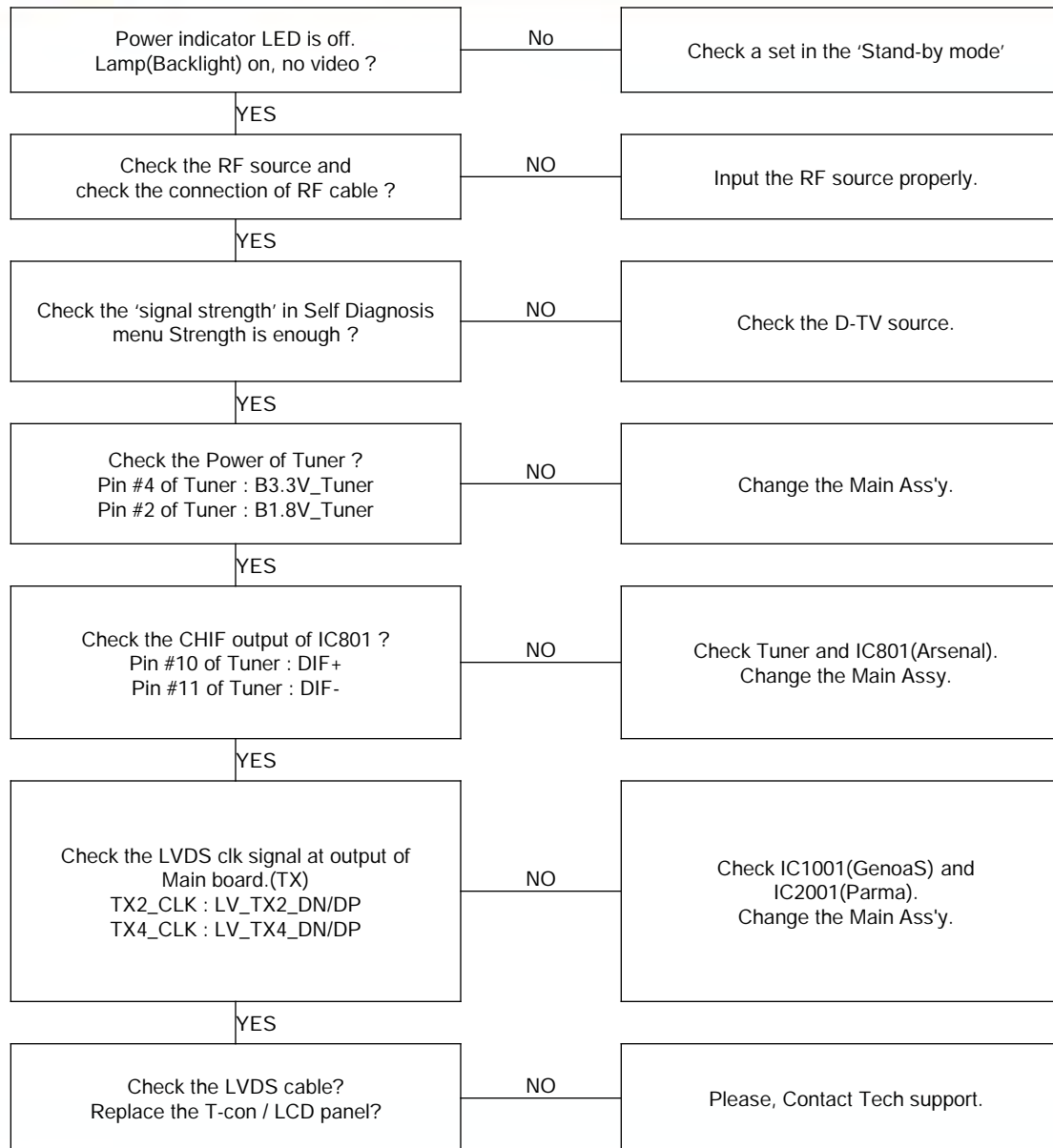



# Trouble Shooting - No Video (Tuner DTV)

5

LVDS output

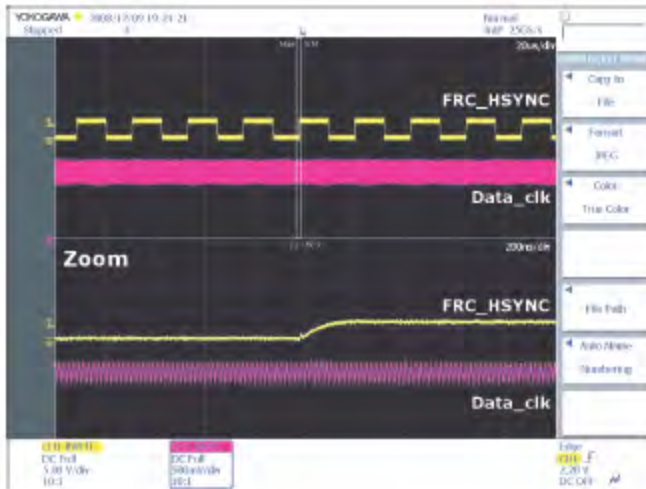

# Trouble Shooting - No Video (Video CVBS)

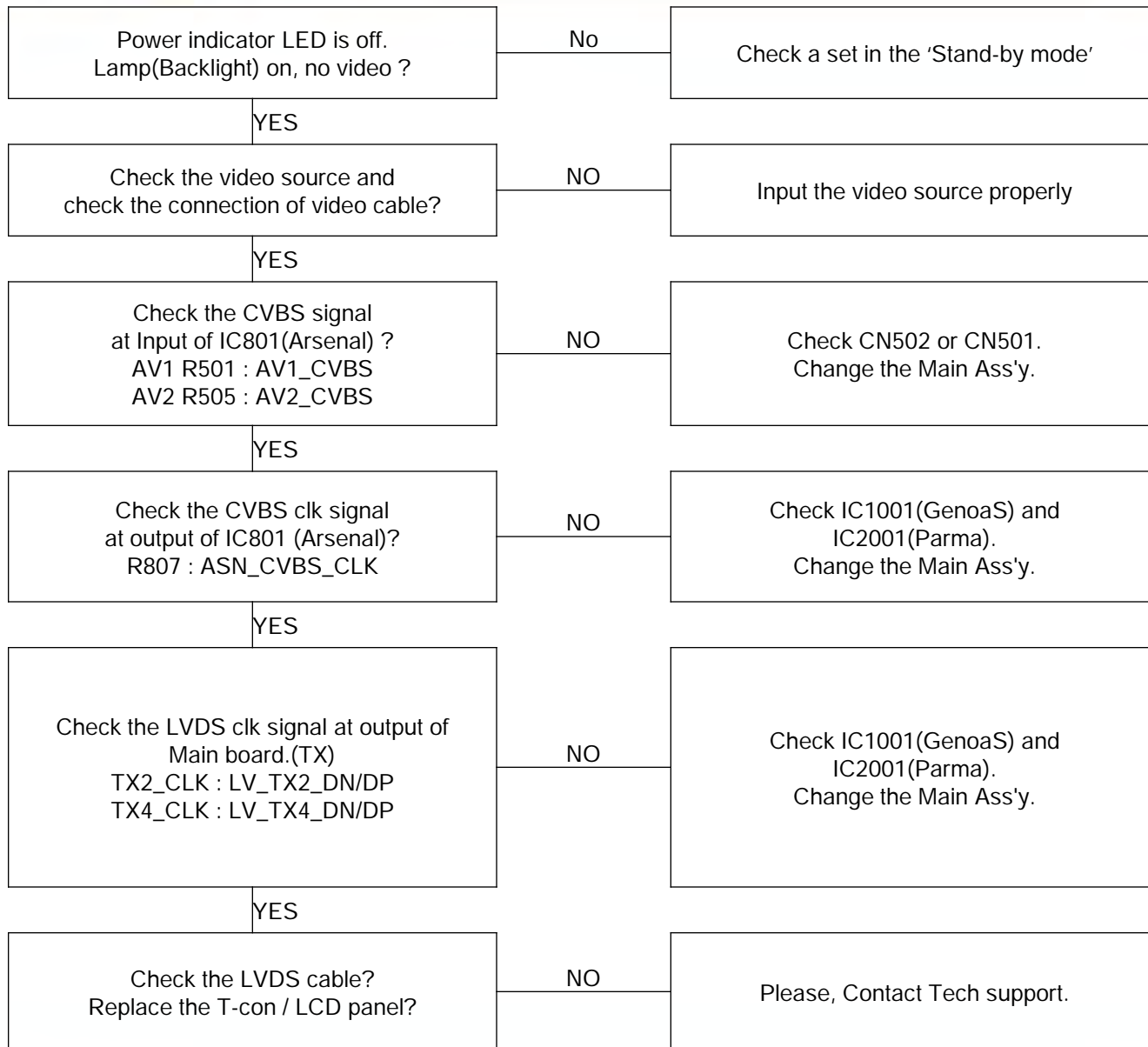

# Trouble Shooting - No Video (Video CVBS)

## 8 CVBS OUT (Grey Bar)

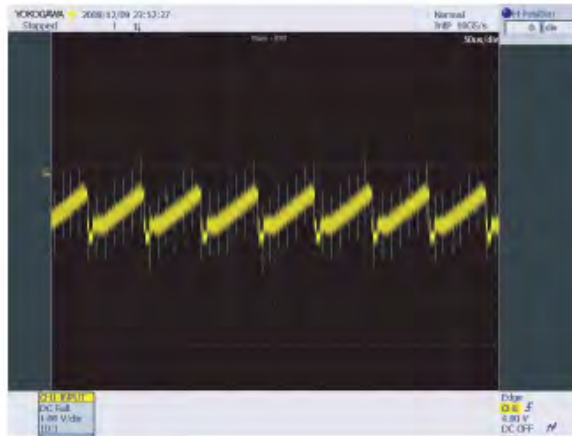

## 5 LVDS output

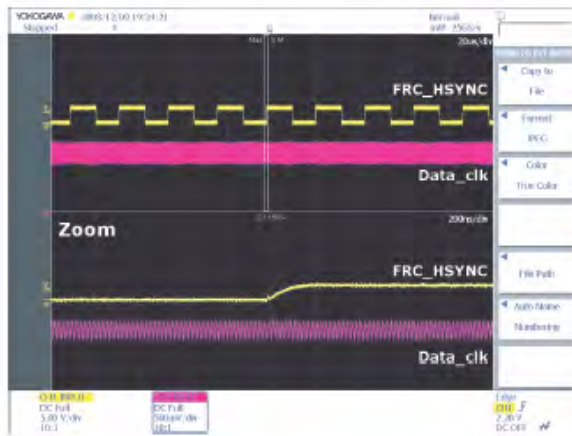

# Trouble Shooting - No Video (Component)

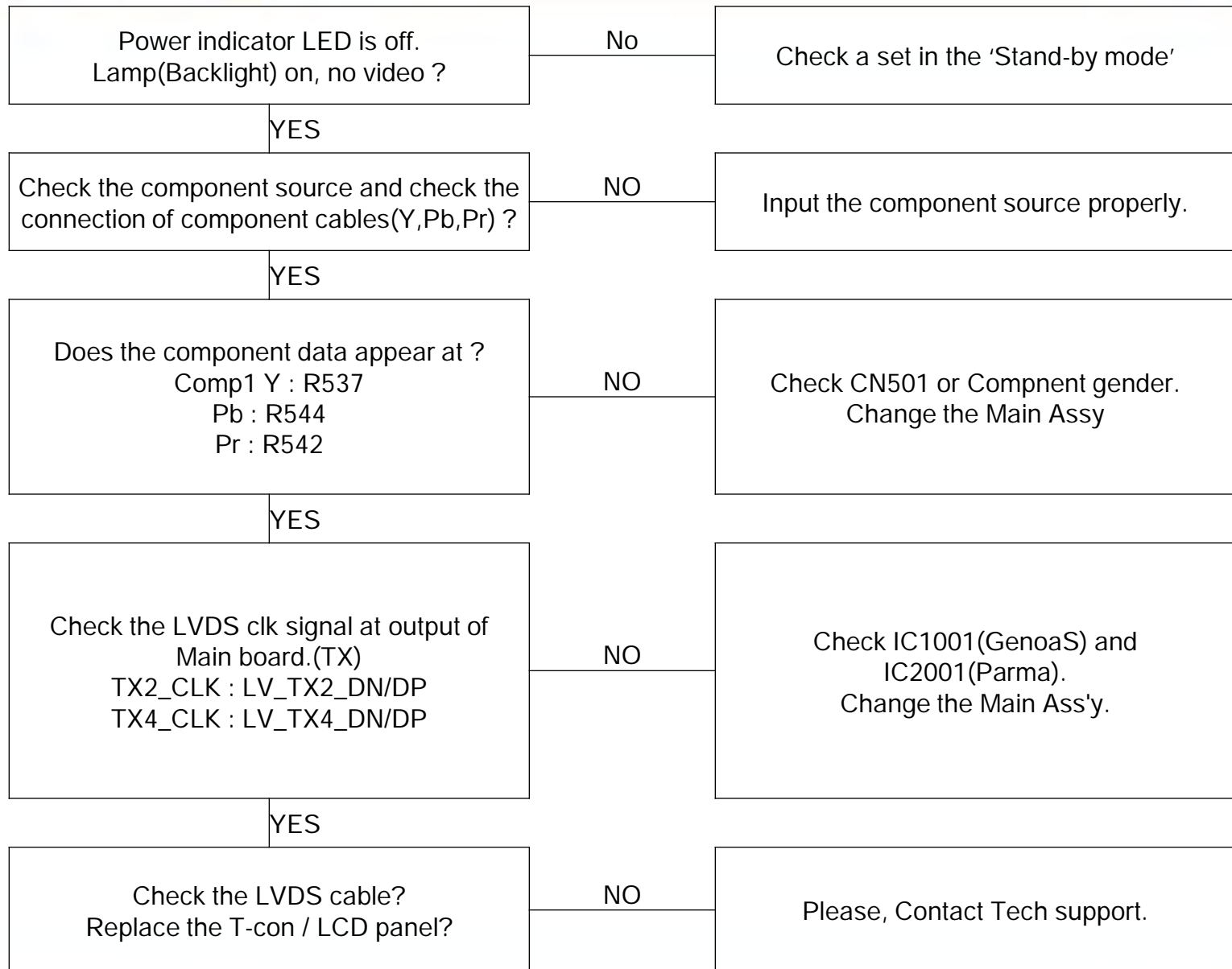

# Trouble Shooting - No Video (Component)

9

Component\_Y (Gray scale) / Pb / Pr (Color bar)

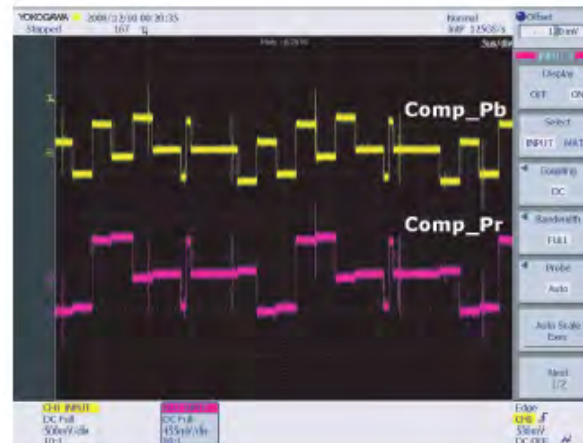
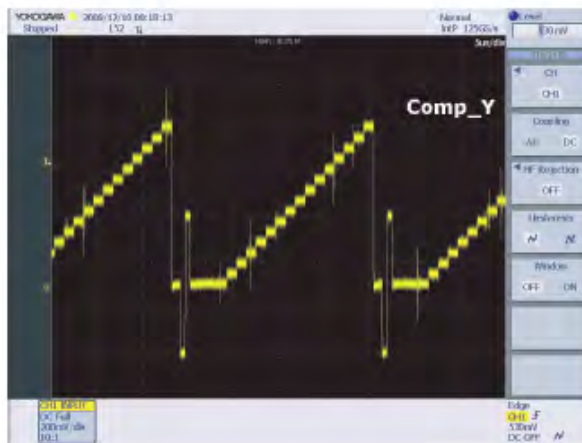

5

LVDS output



# Trouble Shooting – No Sound

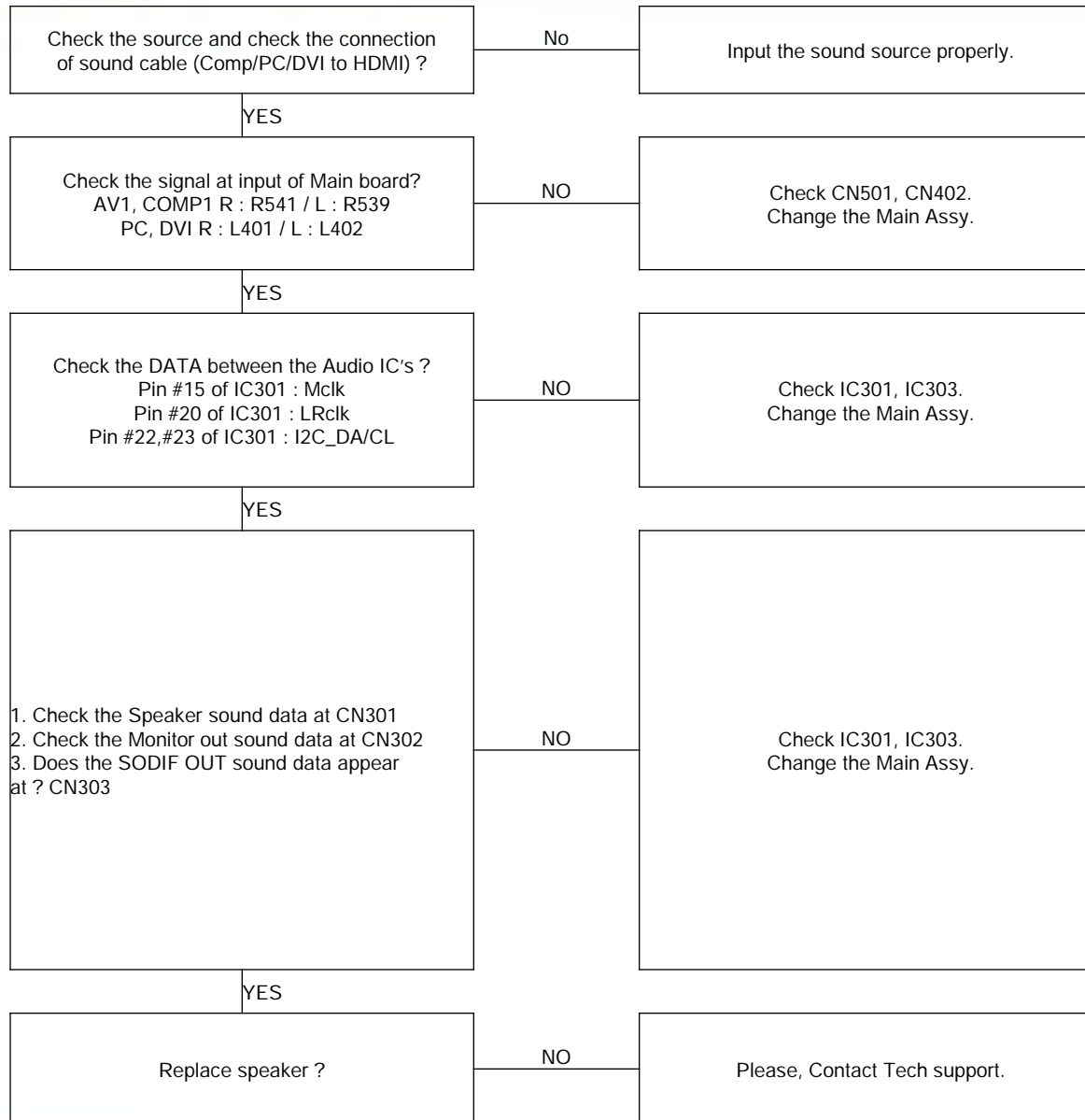



# Trouble Shooting – No Sound

## 10 I2C Data

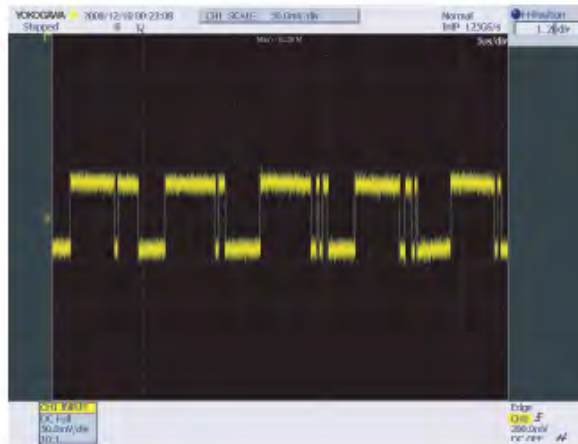

## 11 Speaker out

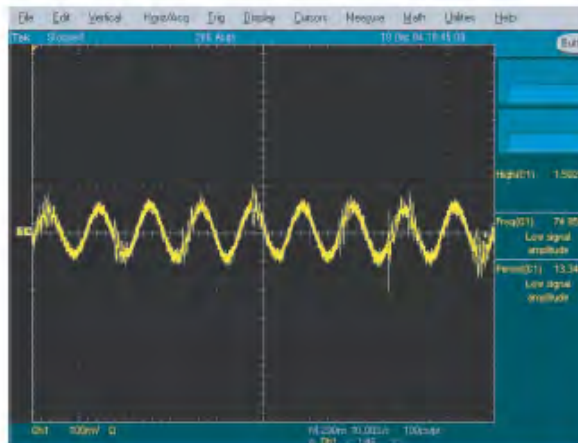

## DOs after changing assembly

- Adjust Panel option, and install EDID data in Factory mode

### <Factory menu>

<b>Option</b>
<b>ADC/WB</b>
<b>Control</b>
<b>Expert</b>
<b>Advanced</b>
T-CHEAUSC-XXXX T-CHEAUSS-XXXX SDAL-4.2.18-0069 RFS Version : 10_64_512_10 T-CHEAUSC 2008-11-20 FRCQ FW : 04B9_CONFIG : 4300 Type : 40A U11 LN40A U11LB650 EDID SUCCESS CALIB : AV X COMP X PC X HMDI X Option : 2432 0100 0 Factory Data Ver : 164 DTP-AP-COMP-060-01 DTP-HIGH-0054 TLIB US3 1G 2008-11-18-01 DTP-BP-0064-03 Date of purchase : 12/3/2008



Factory Reset	
Type	NONE
Model	LB650
TUNER	SEC_Custom
Region	USA
DDR	
Light Effect	OFF
Info Link Type	Canada
Country	0
PDP GROUP	



**Check Point**  
Model : UD6000  
Type :

32" :

40" :

46" :

55" :

<b>Option</b>
<b>ADC/WB</b>
<b>Control</b>
<b>Expert</b>
<b>Advanced</b>
T-CHEAUSC-XXXX T-CHEAUSS-XXXX SDAL-4.2.18-0069 RFS Version : 10_64_512_10 T-CHEAUSC 2008-11-20 FRCQ FW : 04B9_CONFIG : 4300 Type : 40A U11 LN40A U11LB650 EDID SUCCESS CALIB : AV X COMP X PC X HMDI X Option : 2432 0100 0 Factory Data Ver : 164 DTP-AP-COMP-060-01 DTP-HIGH-0054 TLIB US3 1G 2008-11-18-01 DTP-BP-0064-03 Date of purchase : 12/3/2008



<b>EDID</b>
Sub Option
PDP Option
Hotel Option
Shop Option
SOUND



EDID ON/OFF	OFF
EDID WRITE ALL	...
EDID WRITE PC	...
EDID WRITE HDMI	...
EDID 1.2 PORT	...

① EDID on -> ② EDID WRDTE ALL



EDID ON/OFF	ON
EDID WRITE ALL	Success
EDID WRITE PC	Success
EDID WRITE HDMI	Success
EDID 1.2 PORT	NONE

## Factory mode

### 4-3-1 Entering Factory Mode

To enter 'Service Mode' Press the remote-control keys in this sequence :

- If you do not have Factory remote- control

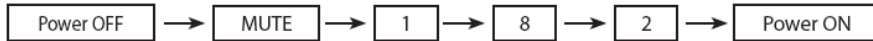

- If you have factory remote-control

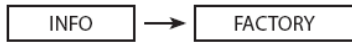

#### 1. Buttons operations withn Service Mode

Menu	Full Menu Display/Move to Parent Menu
Direction Keys ▲/▼	Item Selection by Moving the Cursor
Direction Keys ◀/▶	Data Increase / Decrease for the Selected Item
Source	Cycles through the active input source that are connected to the unit

\* HOW To enter the Advanced menu (Picture)

- Cursor move to 'Advanced'
- Push the '0' button 4 times.
- You can see the 'Picture' menu.

Option	T-TDT6AUSC-****
Control	T-TDT6AUSS-****
SVC	EDID SUCCESS
Expert	CALIB : AV O COMP O PC O HDMI O
ADC/WB	Option : **** **** **
Advanced	
Picture	SDAL-*.***.*
	RFS:P**** T-TDT6AUSC
	YYYY-MM-DD
	Type : ***1UF0C
	Model : LN**C650
	MAC SUCCESS
	Factory Data Ver : ***
	EERC Version : 142
	DTP-AP-COMP_***_**
	DTP-HIIG-***.*
	DTP-BP-****
	Date of purchase : DD/MM/YYYY

- "T-TDT6AUSC" and "T-TDT6AUSS" are firmware version.

# Trouble Shooting

## Factory mode

### ■ Option

<b>Option</b>	Factory Reset	
	Type	40A U11
	Model	LB650
	TUNER	SEC_Custom
	Region	USA
	DDR	
	Light Effect	OFF
	Info Link Type	Canada
	Country	0
	PDP GROUP	

### ■ ADC/WB

<b>ADC</b>	AV Calibration	Failure
	Comp Calibration	...
	PC Calibration	...
	HDMI Calibration	...

<b>ADC Target</b>	1st_AV_Low	64	1st_PC_B_High	...
	1st_AV_High	880	1st_PC_Delta	1
	1st_AV_Delta	1	2nd_AV_R_Low	4
	1st_COMP_Y_Low	16	2nd_AV_G_Low	4
	1st_COMP_Cb_Low	...	2nd_AV_B_Low	4
	1st_COMP_Cr_Low	...	2nd_AV_R_High	940
	1st_COMP_Y_High	940	2nd_AV_G_High	940
	1st_COMP_Cb_High	...	2nd_AV_B_High	940
	1st_COMP_Cr_High	...	2nd_AV_Delta	1
	1st_COMP_Delta	1	2nd_COMP_R_Low	4
	1st_PC_R_Low	16	2nd_COMP_G_Low	4
	1st_PC_G_Low	...	2nd_COMP_B_Low	4
	1st_PC_B_Low	...	2nd_COMP_R_High	940
	1st_PC_R_High	1004	2nd_COMP_G_High	940
	1st_PC_G_High	...	2nd_COMP_B_High	940

<b>ADC Result</b>	2nd_COMP_Delta	1
	2nd_PC_R_Low	4
	2nd_PC_G_Low	4
	2nd_PC_B_Low	4
	2nd_PC_R_High	940
	2nd_PC_G_High	940
	2nd_PC_B_High	940
	2nd_PC_Delta	1
	2nd_HDMI_R_Low	4
	2nd_HDMI_G_Low	4
	2nd_HDMI_B_Low	4
	2nd_HDMI_R_High	940
	2nd_HDMI_G_High	940
	2nd_HDMI_B_High	940
	2nd_HDMI_Delta	1

<b>ADC Result</b>	1st_Y_GH	250
	1st_Y_GL	245
	1st_Cb_BH	...
	1st_Cb_BL	...
	1st_Cr_RH	...
	1st_Cr_RL	...
	2nd_R_L	131
	2nd_G_L	131
	2nd_B_L	131
	2nd_R_H	107
	2nd_G_H	107
	2nd_B_H	107

<b>White Balance</b>	Sub Brightness	128
	R_Offset	512
	G_Offset	512
	B_Offset	512
	Sub Contrast	128
	R_Gain	512
	G_Gain	512
	B_Gain	512
	Movie R_Offset	...
	Movie B_Offset	...
	Movie R_Gain	...
	Movie B_Gain	...

# Trouble Shooting

## Factory mode

EDID	EDID ON/OFF	OFF
	EDID WRITE ALL	...
	EDID WRITE PC	...
	EDID WRITE HDMI	...
	EDID 1.2 PORT	...

Sub Option	RF Mute Time	600ms	LNA Support	0
	SUB U-COM	OFF	WiseLink Movie	ON
	RS-232 Jack	Debug	WiseLink DLNA	ON
	Watchdog	OFF	WiseLink Write	ON
	WD COUNT	0	NETWORK Support	2
	SSC ON/OFF	ON	High Devi	OFF
	SSC MRR	2	Carrier Mute	ON
	SSC MFR	2	Volume Curve	
	SSC QLC	4	HDMI AV MUTE TIME	40
	Gamma	OFF	DVI/HDMI SOUND	Auto
	PANEL DISPLAY TIME	7Hr	HDMI HOT PLUG	Disable
	Dimm Type	EXT	HOT PLUG OFF HOLD	0ms
	LVDS FORMAT	VESA	HDMI FLT CNT SIG	300ms
	Language	...	HDMI FLT CNT LOS	300ms
	UI COLOR	BLUE	UNSTABLE BAN CNT	2500ms

Sub Option	HDMI Err Cnt	2	Font Data Viewer
	HDMI ROBIN	ON	
	PWM MAX	256	
	DVOUT CD	0	
	EDID Jack Ident	OFF	
	Info Link Server Type	operating	
	OTA Duration Test	OFF	
	Alternate Del	OFF	
	OTN Rreset		
	OTN Duration	OFF	
	OTN Fail Test	OFF	
	IIC BUS STOP	OFF	
	Visual Test	Disable	
	Checksum	0x0000	
	View Log	1	

Hotel Option	HOTEL MODE	OFF
	POWER ON CHANNEL	...
	POWER ON BAND	...
	POWER ON VOLUME	...
	MIN VOLUME	...
	MAX VOLUME	...
	PANEL BUTTON LOCK	...
	POWER ON SOURCE	...

Shop Option	Shop Mode	OFF
	USB DEMO ON(SEC)	OFF
	USB DEMO OFF(SEC)	OFF

SOUND	SAP High Threshold	0x40h	Pilot Level Low Thld	0x10h
	SAP Low Threshold	0x20h	A2 Pilot AM Carr High T	...
	Speaker Delay Normal	0x64h	A2 Pilot AM Carr Low T	...
	Auxout Delay Normal	0x64h	NICAM Error High Thld	...
	Spdif Delay Normal	0x0h	NICAM Error Low Thld	...
	Speaker Delay Game	0x28h	FM1 CarrMute High Thld	0x20h
	Auxout Delay Game	0x28h	FM1 CarrMute Low Thld	0x10h
	Spdif Delay Game	0x0h	DRC H Thresh	0x35h
	STA Amp Vol.	0x28h	DRC L Thresh	0x30h
	STA Post Scale	0x7fh	DRC SW Thresh	0x3dh
	STA Speaker EQ	ON		
	STA Sub Woofer	1		
	Mono to Stereo Thld	0x60h		
	Stereo to Mono Thld	0x30h		
	Pilot Level High Thld	0x30h		

# Trouble Shooting

## Factory mode

<b>Config Option</b>	Num of ATV	1	HDMI/DVI SEL	1
	Num of DTV	1	Indicator Led	OFF
	Num of AV	2	Wall Mount	OFF
	Num of SVIDEO	0	Chelsea HV Filp	OFF
	Num of COMP	2		
	Num of HDMI	4		
	Num of PC	1		
	Num of SCART	0		
	Num of DVI	0		
	Num of OPTICAL Link	0		
	Num of MEDIA	1		
	Num of PANEL KEY	6		
	Num of USB Port	2		
	MFT Offset	62,5		
	Select LCD/PDP	LCD		

### ■ Expert

<b>Expert</b>	N/D ADJ	OFF
	Source	...

### ■ Advanced

#### ■ FBE3

<b>FBE3</b>	Pattern_sel	0	Skin-Enable	ON
	BM_slope1	19	Skin-UV	135
	BM_slope2	36	FBE Sub color	128
	BM_slope3	56	M-Skin-UV	...
	BM_slope4	75	M-Sub Color	...
	BM_start	68		
	BM_start_max	110		
	Lfunc_basis	60		
	Hfunc_basis	70		
	Mean-Offset1	30		
	Mean-Offset2	235		
	Mean-Slope	112		
	ACR-Offset	10		
	ACR-th1	10		
	ACR-th2	110		



# Trouble Shooting

## Factory mode

### ■ WB Movie

<b>WB Movie</b>	W/B MOVIE ON/OFF MODE	0x40h	W2_Roffset	...
	Color Tone	...	W2_Boffset	...
	Msub Brightness	...	W3_Rgain	...
	Msub Contrast	...	W3_Bgain	...
	N_Rgain	...	W3_Roffset	...
	N_Bgain	...	W3_Boffset	...
	N_Roffset	...	Movie Contrast	...
	N_Boffset	...	Movie Bright	...
	W1_Rgain	...	Movie color	...
	W1_Bgain	...	Movie Sharpness	...
	W1_Roffset	...	Movie Tint	...
	W1_Boffset	...	Movie Backlight	...
	W2_Rgain	...	Movie Gamma	...
	W2_Bgain	...	M_Sub_Gamma	...

### ■ EPA Standard

<b>EPA Standard</b>	Standard Contrast	95
	Standard Brightness	45
	Standard Sharpness	50
	Standard Color	50
	Standard Tint	0
	Standard Backlight	7

### ■ CH\_VDEC

<b>CH_VDEC</b>	AGC_mode	1	CTI_level	15
	Gain_VCR	0	ST_Beg_NTSC	0
	Y_Gain_Man	880	VS_Slice_Level	4
	Saturation	128	HS_Slice_Level	3
	Hue	0	FB_Delay_adj	0
	Y_Shape_sel	13	RGB_Delay_adj	0
	Y_Shape_SCM	29	h_pk_gain	0
	C_Shape_sel	4	v_pk_gain	0
	C_Shape_SCM	4	h_pk_band	0
	If_ir	0	2d_pk_gain	0
	If_filt_sel	6	2d_pk_band	1
	LTI_en	OFF	slice_mod_fine	0
	LTI_level	100	slice_fdet_lvl	150
	CTI_en	OFF		
	SCM_STI_EN	OFF		

### ■ YC\_Delay

<b>YC_Delay</b>	V_Delay_adj	0
	U_Delay_adj	0

### ■ AR\_ADC

<b>AR_ADC</b>	RED_CUTOFF	-3
	GREEN_CUTOFF	0
	BLUE_CUTOFF	-3
	RED GAIN	-4
	GREEN GAIN	0
	BLUE GAIN	-6
	PHASE	0
	SOG_BW	4
	SSC_PC	6
	RGB_DLY	0

### ■ CH\_DP

<b>CH_DP</b>	MNR	OFF	MJC_DBG	0
	DCR	OFF	MB_STEPS	72
	SD2HD_DCR	OFF	LIMIT_MV_STEP	80
	SD2HD_DE	OFF	GLOBAL_FALLBACK	48
	SD2HD_SCL	OFF	LOCAL_FALLBACK	5
	SD2HD_LTI	OFF		
	SD2HD_NARS	0		
	SD2HD_DUR	50		
	SD2HD_Metric	207		
	Coring_ON_OFF	ON		
	SD_CSC	7094		
	HD_CSC	7438		
	M_SD_CSC	7094		
	M_HD_CSC	7438		
	PC_SD_CSC	7094		

# Trouble Shooting

## Factory mode

### ■ NR

<b>NR</b>	OFF_Y	8	HIGH_Y	80
	OFF_C	4	HIGH_C	20
	OFF_Noise_bias	1	HIGH_Noise_bias	1
	OFF_YMAX	128	HIGH_YMAX	170
	OFF_FADER	200	HIGH_FADER	155
	LOW_Y	65		
	LOW_C	18		
	LOW_Noise_bias	1		
	LOW_YMAX	140		
	LOW_FADER	160		
	MED_Y	75		
	MED_C	20		
	MED_Noise_bias	1		
	MED_YMAX	160		
	MED_FADER	160		

### ■ Sharpness

<b>Sharpness</b>	Pre_GainH1	6	SD_LTIH	16
	Pre_GainH2	22	SD_LTIV	24
	Pre_GainH3	15	PRE_CORING	200
	Post_GainH1	6	POST_CORING_H	200
	Post_GainH2	22	POST_CORING_V	200
	Post_GainH3	15	Pre_TOT	32
	Post_GainV1	40	Post_TOT	32
	Post_GainV2	50	SP Sub Color	59
	Post_GainV3	20		
	CTI_Gain	15		
	Pre_LTIH	4		
	SD_TH	100		
	HD_TH	132		
	NORMAL_LTIH	8		
	NORMAL_LTIV	4		

### ■ Sharpness\_LNA

<b>Sharpness_LNA</b>	S1_Pre_GainH1	4	S2_Post_GainV1	20
	S1_Pre_GainH2	16	S2_Post_GainV2	30
	S1_Pre_GainH3	11	S2_Post_GainV3	10
	S1_Post_GainH1	4	S3_Pre_GainH1	1
	S1_Post_GainH2	16	S3_Pre_GainH2	4
	S1_Post_GainH3	11	S3_Pre_GainH3	3
	S1_Post_GainV1	30	S3_Post_GainH1	1
	S1_Post_GainV2	35	S3_Post_GainH2	4
	S1_Post_GainV3	15	S3_Post_GainH3	3
	S2_Pre_GainH1	2	S3_Post_GainV1	10
	S2_Pre_GainH2	10	S3_Post_GainV2	15
	S2_Pre_GainH3	7	S3_Post_GainV3	5
	S2_Post_GainH1	2		
	S2_Post_GainH2	10		
	S2_Post_GainH3	7		

### ■ CE DIMMING

<b>CE DIMMING</b>	Contrast Dimming	OFF
	Dimming in Standard	ON
	Dimming in Movie	ON

### ■ LNA\_Plus

<b>LNA_Plus</b>	Synctip_Noise	14
	dB01_th	16
	dB12_th	48
	dB23_th	73
	dB34_th	185
	dB45_th	318
	S1_Post_GainV1	30

# Trouble Shooting

## Factory mode

### ■ FRC

<b>FRCQ Option</b>	SSC_OnOff	ON	X_HaloSizSensF	32
	SSC_Width	96	Film_Low_SD	12
	SSC_Freq	240	Film_Medium_SD	3
	FMD_Demo	0	Film_High_SD	0
	PATT_BeforeDDR	0	Film_Low_HD	12
	PATT_AfterDDR	0	Film_Medium_HD	3
	CBS Vertical	ON	Film_High_HD	0
	CBS Horizontal	ON	Video_Judder_Low	10
	X_VStabStatVid	7	Video_Judder_Med	5
	X_VStabStatF	0	Video_Judder_High	0
	X_VStabCorF	8	Hangup Detection	ON
	X_VStabSensF	48	Q LVDS Sequence	0-1-2-3
	X_HaloSizStatVid	7	Q LVDS Format	JEIDA
	X_HaloSizStatF	0	Q LVDS bit width	10bit
	X_HaloSizCorF	12		

<b>FRCQ Fallback</b>	SensD_Film_Low	31	V-Len_Slope_Video	1
	SensD_Film_Medium	31		
	SensD_Film_High	31		
	Rel_Start_Film	20		
	Rel_Slope_Film	3		
	H-Len_Start_Film	127		
	H-Len_Slope_Film	1		
	V-Len_Start_Film	40		
	V-Len_Slope_Film	1		
	SensD_Video	0		
	Rel_Start_Video	20		
	Rel_Slope_Video	1		
	H-Len_Start_Video	127		
	H-Len_Slope_Video	1		
	V-Len_Start_Video	40		

### ■ PQ Others

<b>PQ Others</b>	7.5 IRE NTSC	...
	7.5 IRE OFFSET	...
	HDMI 48Hz Enable	

### ■ EEPROM RESET

<b>EEPROM RESET</b>	EER RESET NVR All Clear	OFF
---------------------	----------------------------	-----

## Compatibility problem

### HDMI

1. Symptoms : Star noise.  
Trouble shooting :  
Factory mode -> Control -> Config option -> HDMI EQ Change  
OR  
Factory mode -> Sub Option -> DVOUT CD : level change
2. Symptoms : Can not detect HDMI devices.  
Trouble shooting : Factory mode -> Control -> Config option  
-> HDMI Hot Plug : Disable  
(Default value of HDMI Hot Plug is 'Enable')

### Component

1. Symptoms : Star noise  
Trouble shooting :  
Factory mode -> Sub Option -> DVOUT CD : level change

## Adjustment (Calibration -> White Balance)

### Calibration

Pattern : MIK K-7256 #24 'Chessboard Pattern'  
Set Aging time : 60min↑

- HDMI Calibration (Time #6, 720p)
- COMP Calibration (Time #6, 720p)
- CVBS Calibration (Time #3, NTSC-J)
- PC Calibration (Time #21, 1024\*768)

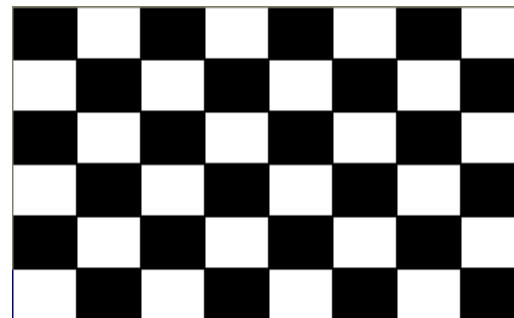

### <Factory menu>

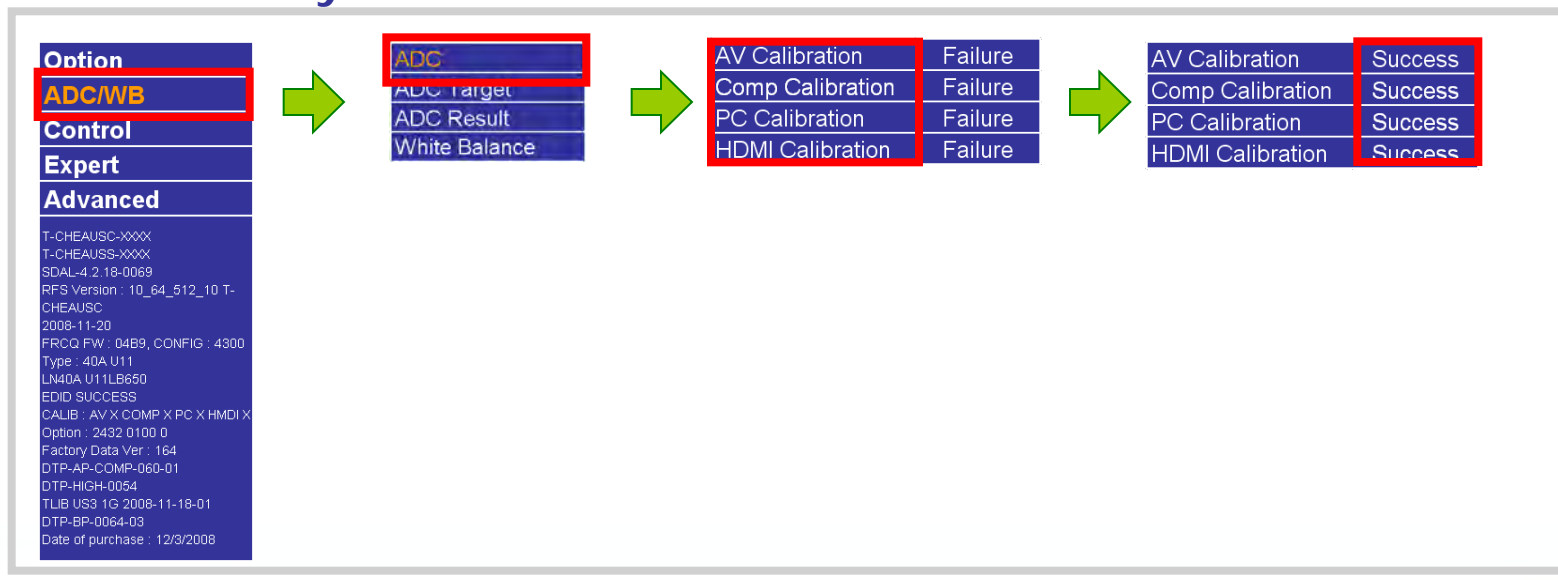

# White balance

## Adjustment (Calibration → White Balance)

### White Balance

Test : CA-210  
 Pattern : MIK K-7256 #92 'Flat W/B Pattern'  
 Set Aging time : 60min↑

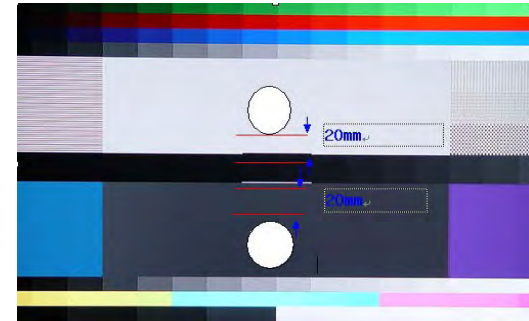

#### <Factory menu>

#### <Adjustment value>

40inch

<b>Option</b>
<b>ADC/WB</b>
<b>Control</b>
<b>Expert</b>
<b>Advanced</b>
T-CHEAUSC-XXXX T-CHEAUSS-XXXX SDAL-4.2.18-0069 RFS Version : 10_64_512_10 T- CHEAUSC 2008-11-20 FRCQ FW : 04B9, CONFIG : 4300 Type : 40A U11 LN40A U11LB650 EDID SUCCESS CALIB : AV X COMP X PC X HDMI X Option : 2432 0100 0 Factory Data Ver : 164 DTP-AP-COMP-060-01 DTP-HIGH-0054 TLIB US3 1G 2008-11-18-01 DTP-BP-0064-03 Date of purchase : 12/3/2008

ADC
ADC Target
ADC Result
<b>White Balance</b>

Sub Brightness	128
R_Offset	512
G_Offset	512
B_Offset	512
Sub Contrast	128
R_Gain	512
G_Gain	512
B_Gain	512
Movie R_Offset	...
Movie R_Offset	...
Movie R_Gain	...
Movie B_Gain	...

P-Mode	Measurement (CA-210)				
	Input signal	x	y	Y	T(K) / MPCD
[ Dynamic Cool1 ]				66.5 fL	
HDMI	H/L	272	278	(Sub_CT:133 Fix)	12,000 (±0)
Comp					
CVBS	L/L	272	278	4.9 fL (Sub-Brt:128 Fix)	12,000 (±0)
[ Movie Warm2 ]				-	
HDMI	H/L	306	327	(Sub_CT:Fix)	6,500 (+6)
Comp					
CVBS	L/L	306	327	- (Sub_Brt:Fix)	6,500 (+6)
				Movie Gamma:OFF	

**Important Spec.**

**SUB-CONTRAST: 133, Gamma: 0.95**



## USB Download

Samsung may offer upgrades for TV's firmware in the future. Please contact the Samsung call center at 1-800-SAMSUNG (726-7864) to receive information about downloading upgrades and using a USB drive. Upgrades will be possible by connecting a USB drive to the USB port located on your TV.

1. Insert a USB drive containing the firmware upgrade into the WISELINK port on the side of the TV.
2. Press the **MENU** button to display the menu.  
Press the **▲** or **▼** button to select "Setup", then press the **ENTER** button.
3. Press the **▲** or **▼** button to select "SW Upgrade", then press the **ENTER** button.
4. Press the **ENTER** button.  
The message "Scanning for USB... It may take up to 30 seconds." is displayed.
5. The message "Upgrade version XXXX to version XXXX?" is displayed.  
The system will be reset after upgrade.  
Press the **◀** or **▶** to select the "OK", then press the **ENTER** button.

Please be careful to not disconnect the power or remove the USB drive while upgrades are being applied. The TV will turn off and turn on automatically after completing the firmware upgrade. Please check the firmware version after the upgrades are complete. When software is upgraded, video and audio settings you have made will return to their default (factory) settings. We recommend you write down your settings so that you can easily reset them after the upgrade.

\*How to check Program Version

1. Press "MENU"
2. Select "SETUP"
3. Cursor position "SW Upgrade"
4. Press "INFO"

