

PFC

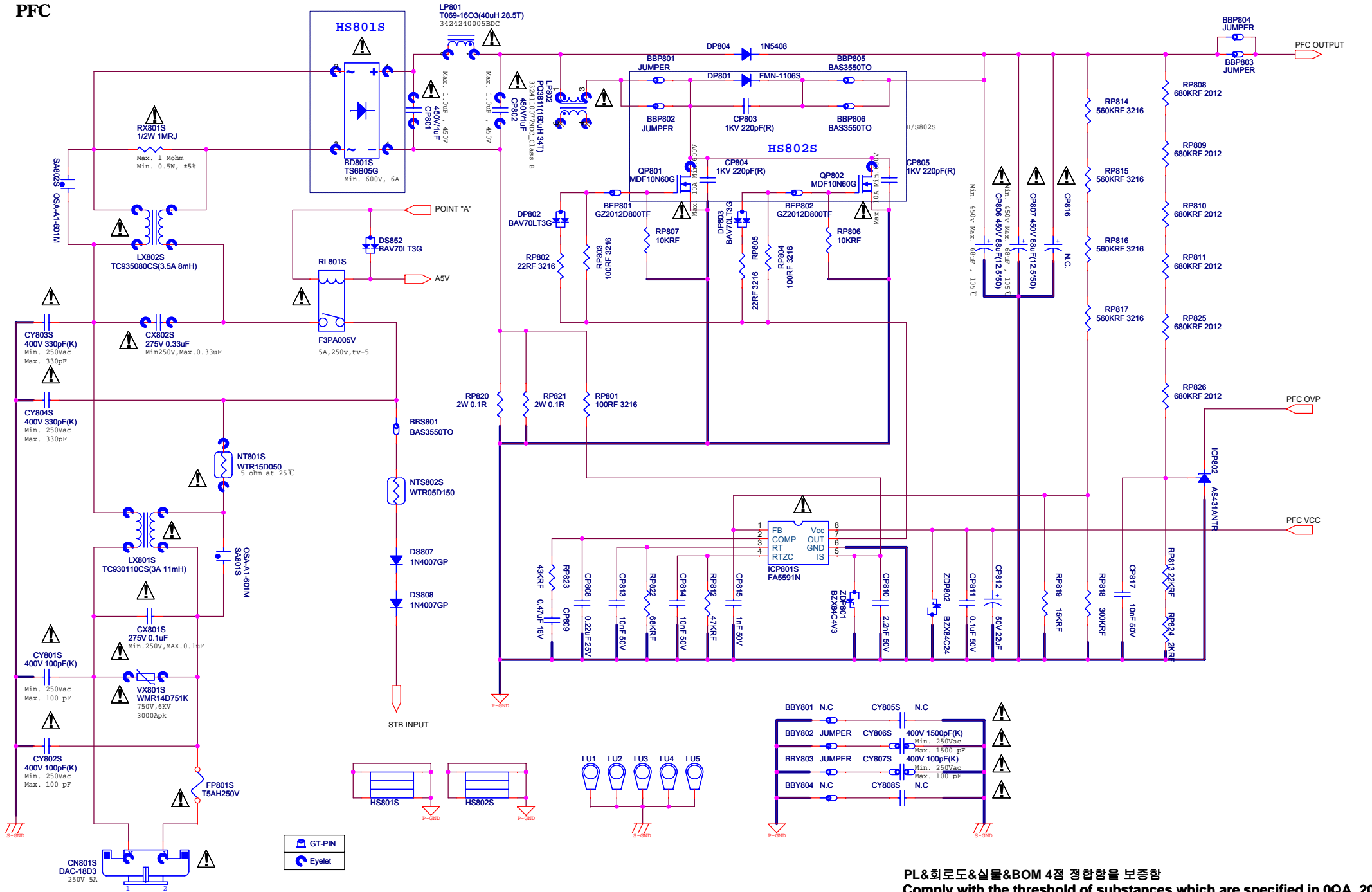

GT-PIN  
Eyelet

PL&회로도&실물&BOM 4점 정합함을 보증함  
Comply with the threshold of substances which are specified in 0QA\_209

NOTE  
 \*\* NC : No Connection  
 \*\* No marking resistor 1608 1% SMD  
 \*\* No marking capacitor 1608 X7R SMD

N.C POINT : CY805S, CY808S, BBY801, BBY804, CP816

MODEL NAME	PD55B2_BHS	SCALE	A3	DESIGNER	S.K. YOO
FIGURE NO.	REV R.E	DATE		DESIGNED BY	T.H.KANG
FIGURE NUMBER	BN44-00428B	APPROVED		APPROVED	S.K. HWANG

# STAND BY

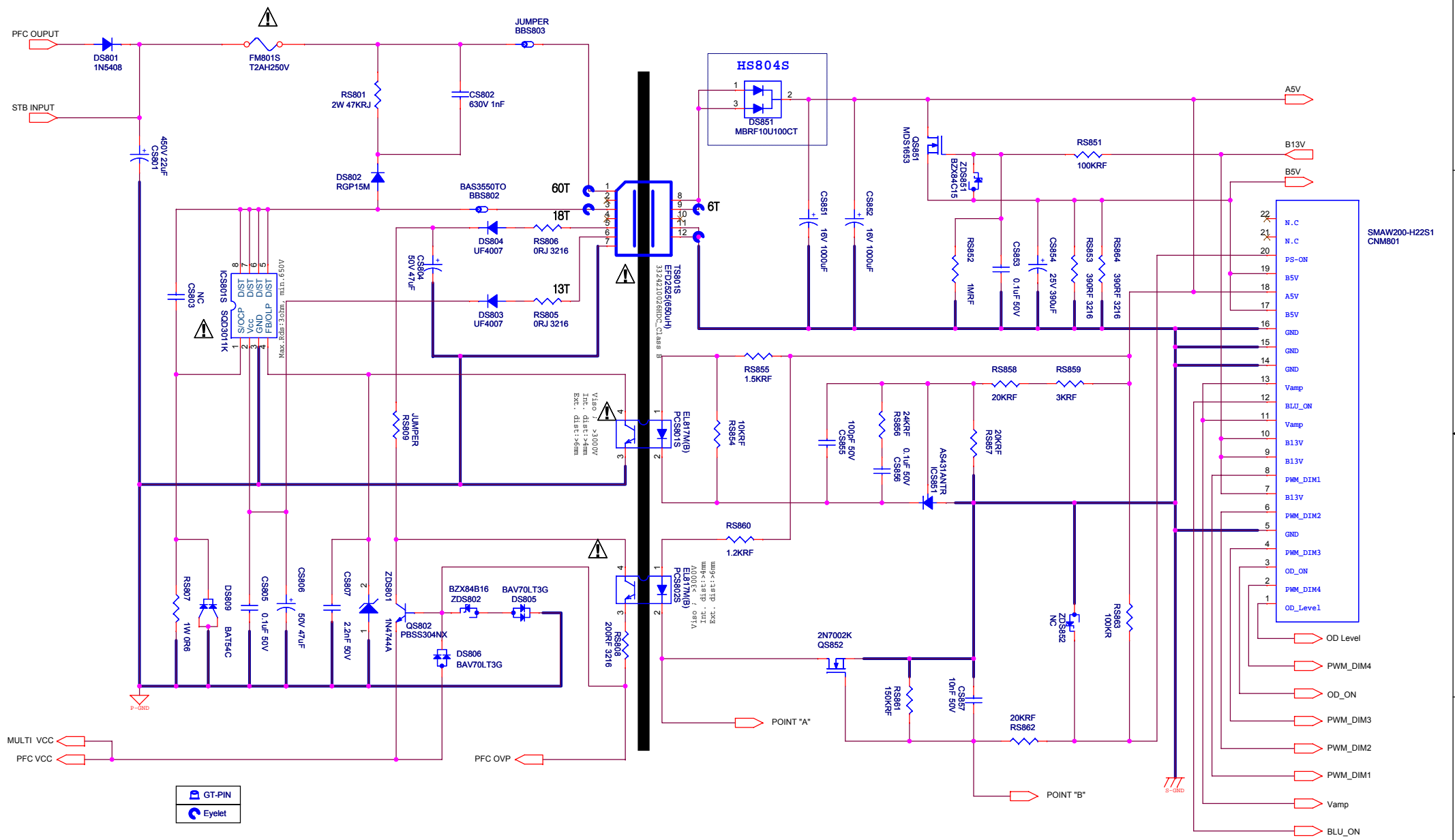

NOTE  
 \*\* NC : No Connection  
 \*\* No marking resistor 1608 1% SMD  
 \*\* No marking capacitor 1608 X7R SMD

N.C POINT : CS803, ZDS852

PL&회로도&실물&BOM 4점 정합함을 보증함  
 Comply with the threshold of substances which are specified in 0QA\_209

	MODEL NAME	SCALE	DESIGN
	PD55B2_BHS	A3	S.K. YOO
	REV R.E		T.H.KANG
	PN NUMBER		APPROVED
BN44-00428B			S.K. HWANG

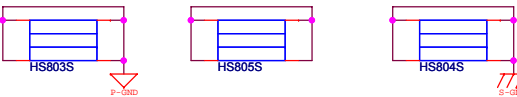
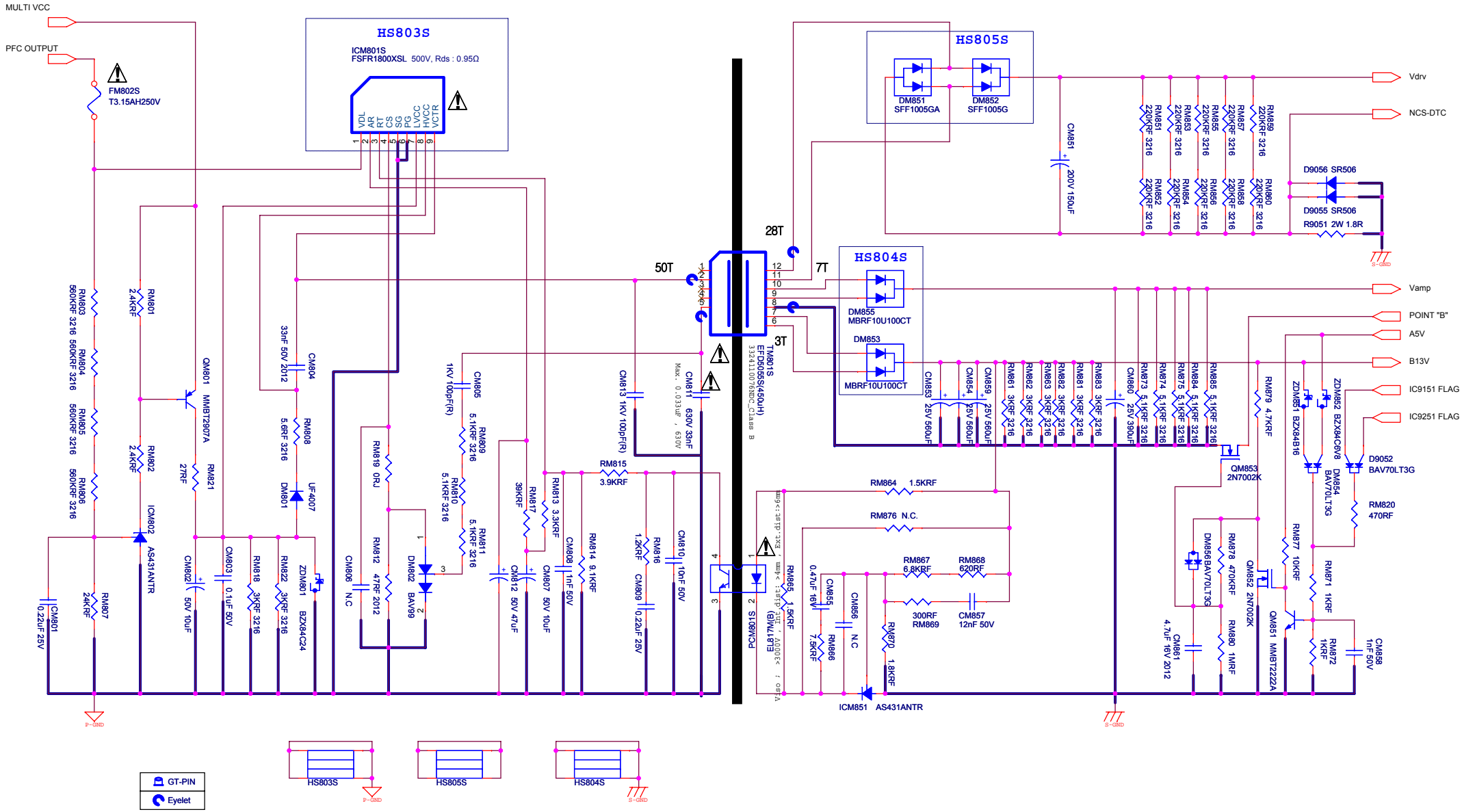

NOTE

- \*\* NC : No Connection
- \*\* No marking resistor 1608 1% SMD
- \*\* No marking capacitor 1608 X7R SMD

N.C POINT : CM806, CM856, RM876

PL&회로도&실물&BOM 4점 정합함을 보증함  
Comply with the threshold of substances which are specified in 0QA\_209

	USER	SCALE	DATE
	MODEL NAME PD55B2_BHS	A3	DRW S.K.YOO
	REV NUMBER BN44-00428B	REV R.E	CHK T.H.KANG
			APPROV S.K. HWANG

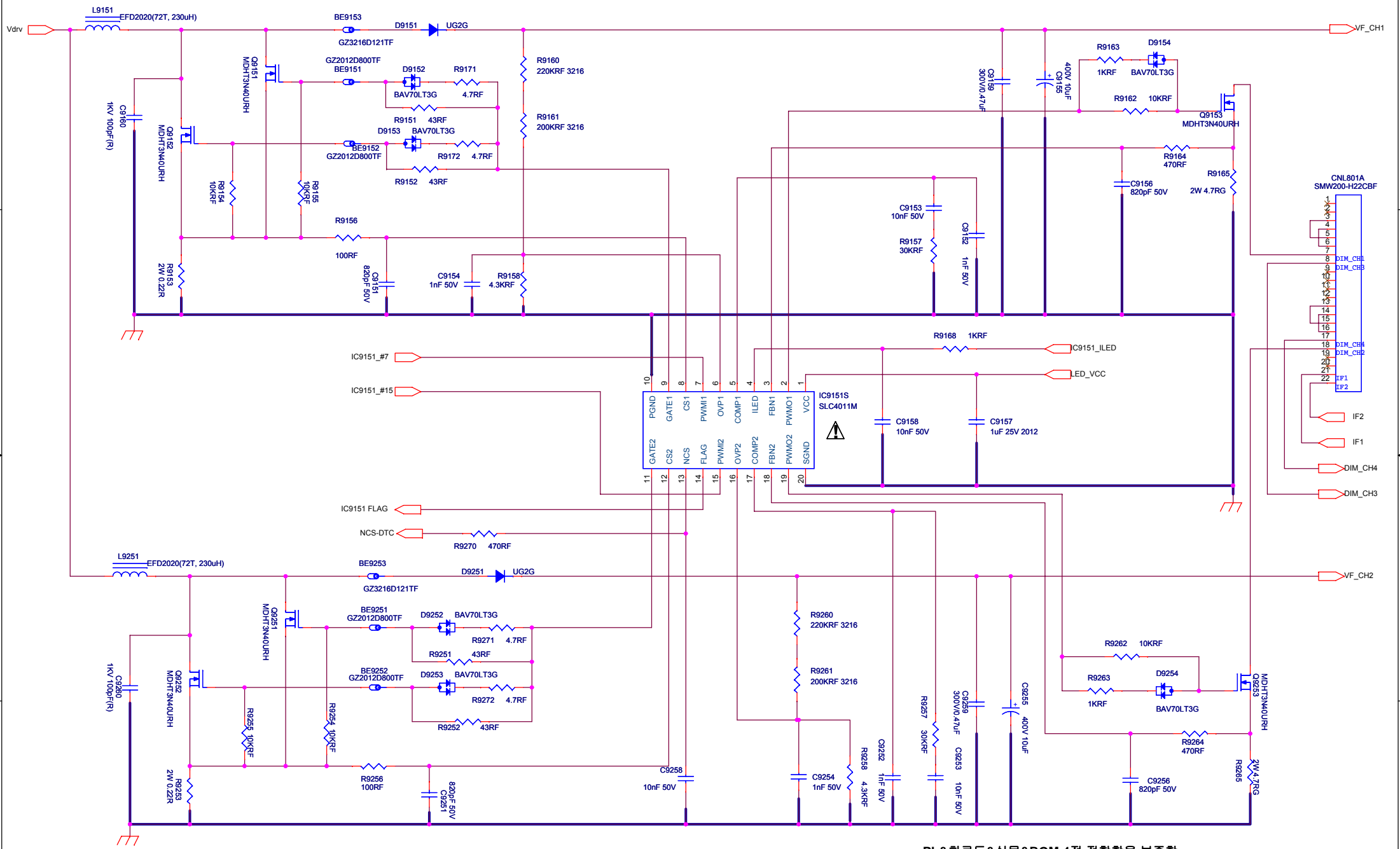

PL&회로도&실물&BOM 4점 정합함을 보증함  
 Comply with the threshold of substances which are specified in 0QA\_209

NOTE  
 \*\* NC : No Connection  
 \*\* No marking resistor 1608 1% SMD  
 \*\* No marking capacitor 1608 X7R SMD

		MODEL NAME PD55B2_BHS	SCALE A3	DRAWN S.K. YOO
		P/N NUMBER BN44-00428B	REV R.E	T.H.KANG
				S.K. HWANG

# LED DRIVER

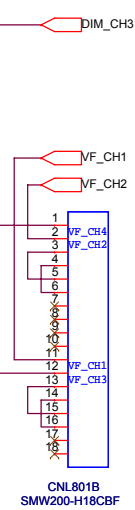
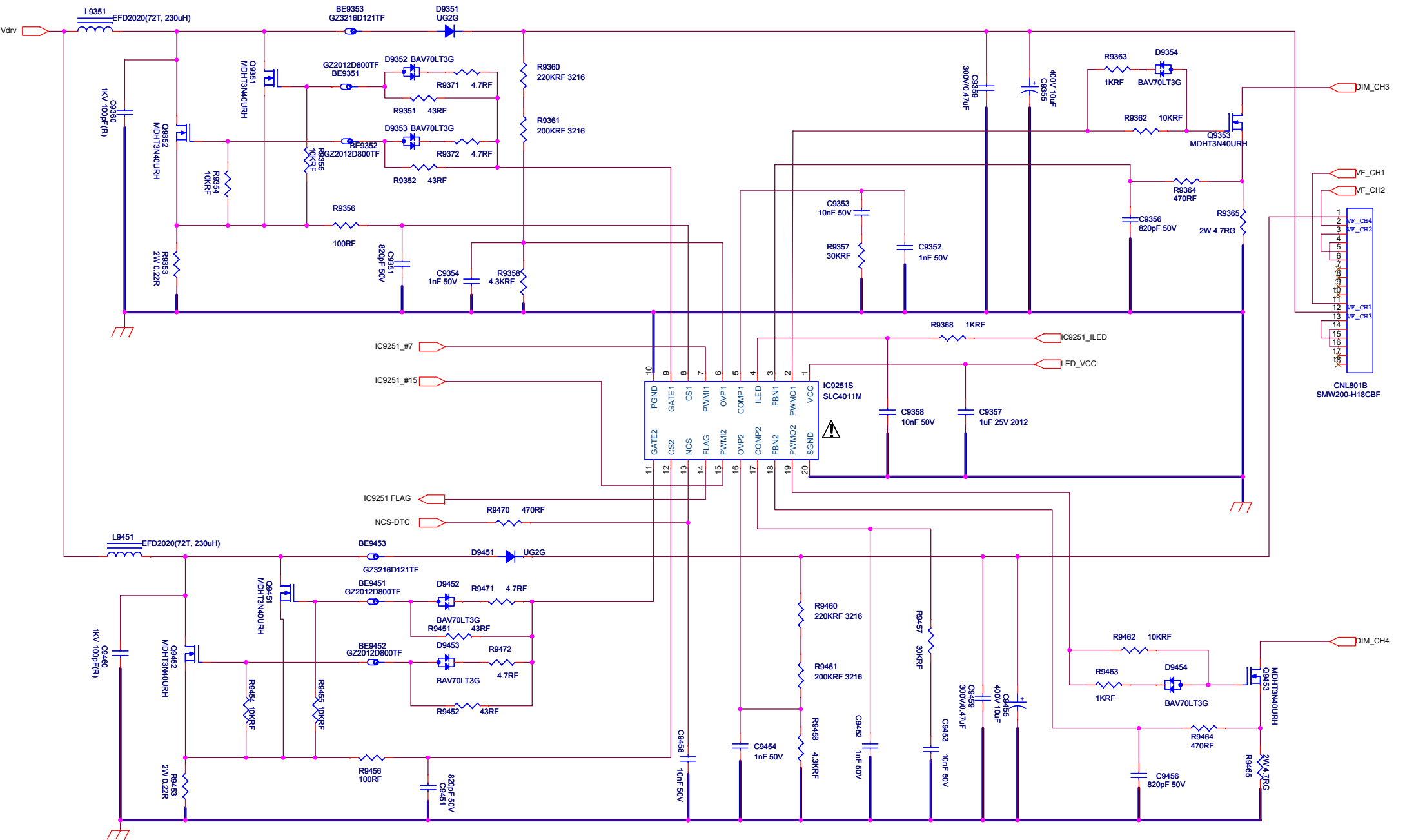

PL&회로도&실물&BOM 4점 정합함을 보증함  
 Comply with the threshold of substances which are specified in 0QA\_209

NOTE  
 \*\* NC : No Connection  
 \*\* No marking resistor 1608 1% SMD  
 \*\* No marking capacitor 1608 X7R SMD

		MODEL NAME <b>PD55B2_BHS</b>	SCALE <b>A3</b>	DRAWN <b>S.K. YOO</b>
		PART NUMBER <b>BN44-00428B</b>	REV <b>REV R.E</b>	CHECKED <b>T.H.KANG</b>
				APPROVED <b>S.K. HWANG</b>

# LED DRIVER

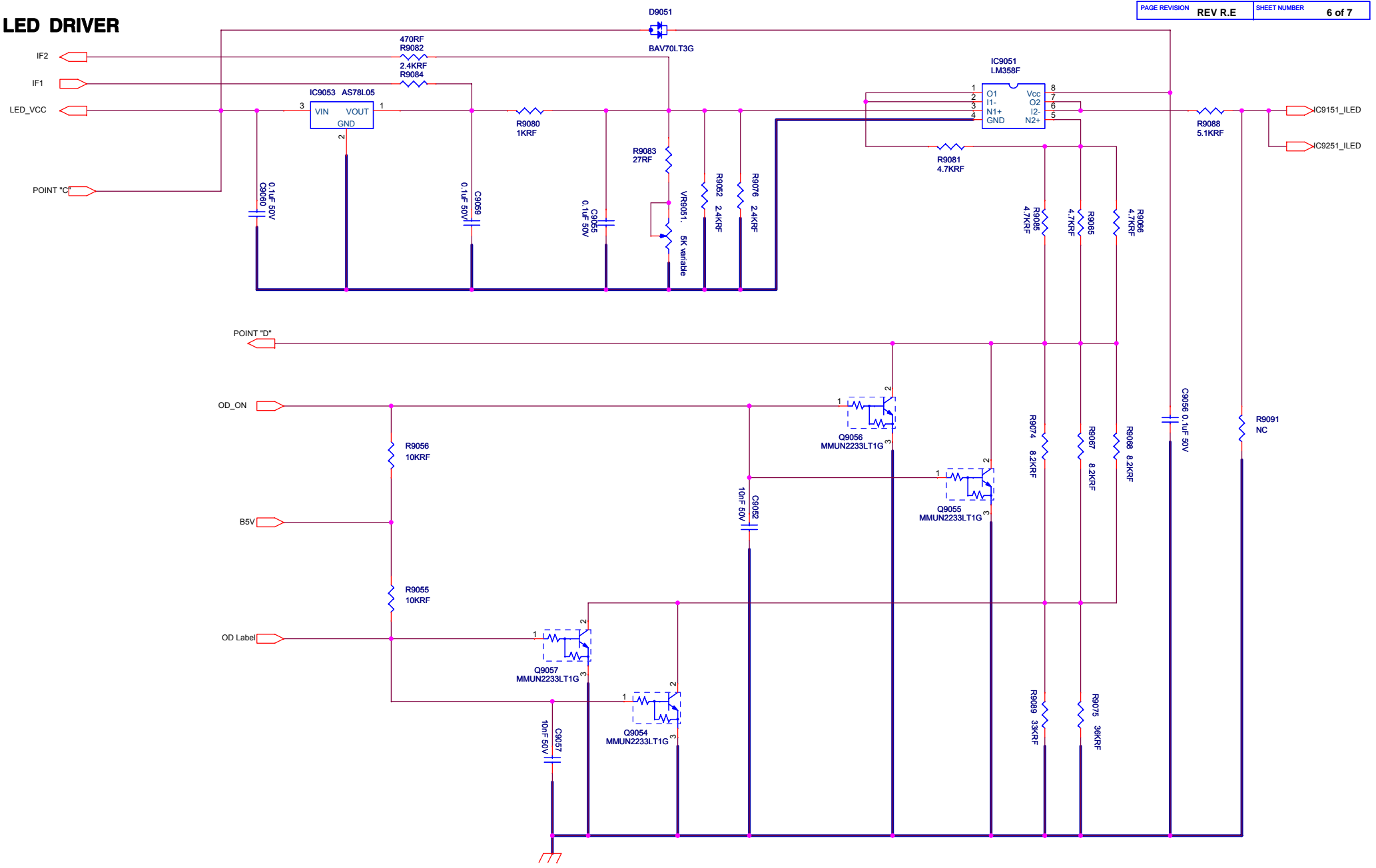

NOTE  
 \*\* NC : No Connection  
 \*\* No marking resistor 1608 1% SMD  
 \*\* No marking capacitor 1608 X7R SMD

N.C POINT : R9091

PL&회로도&실물&BOM 4점 정합함을 보증함  
 Comply with the threshold of substances which are specified in 0QA\_209

	MODEL NAME	SCALE	DESIGN
	PD55B2_BHS	A3	S.K. YOO
	FORM NUMBER	REV R.E	DATE
	BN44-00428B		T.H.KANG
		APPROVED	
		S.K. HWANG	

# LED DRIVER

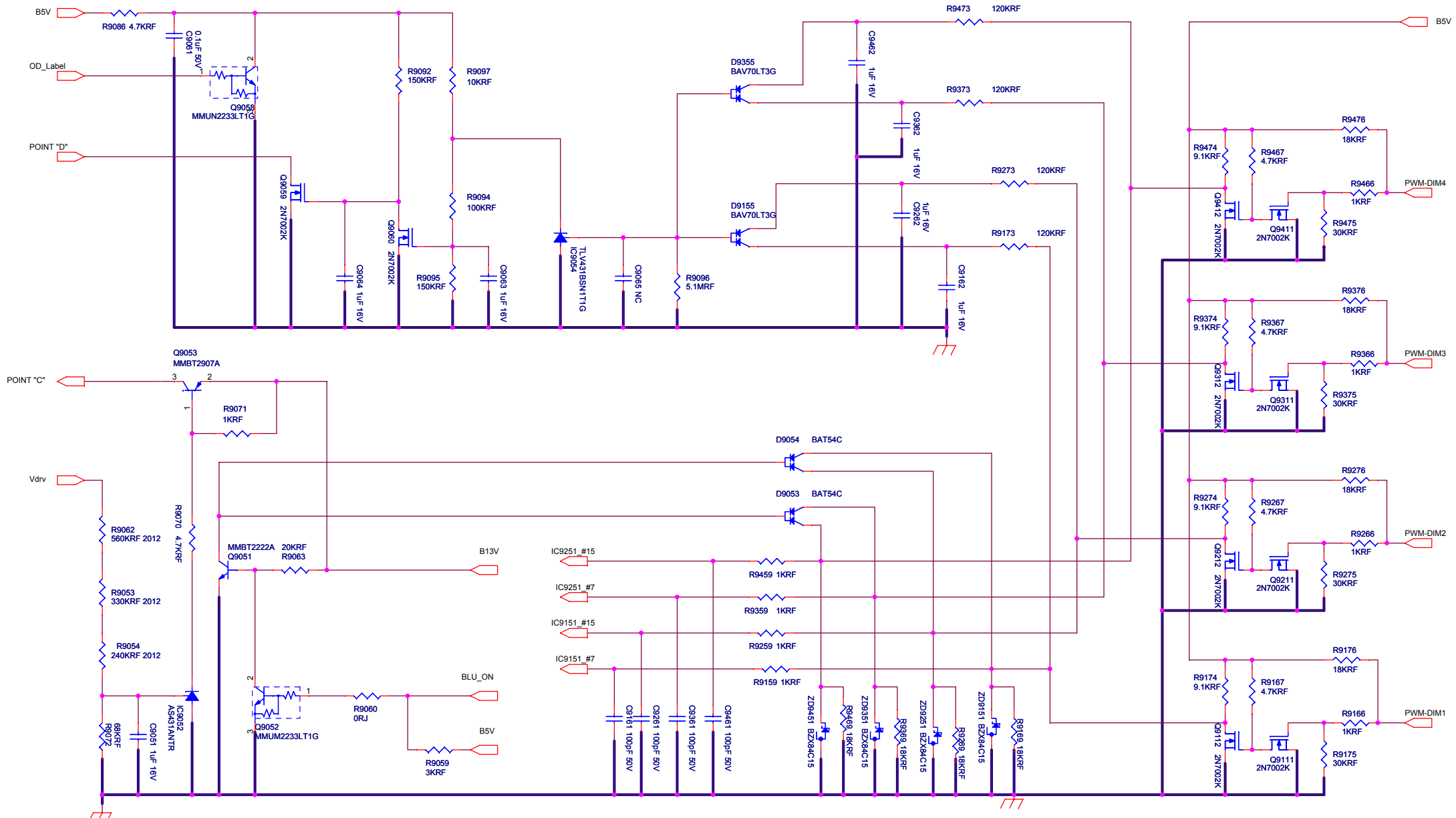

PL&회로도&실물&BOM 4점 정합함을 보증함  
 Comply with the threshold of substances which are specified in 0QA\_209

NOTE  
 \*\* NC : No Connection  
 \*\* No marking resistor 1608 1% SMD  
 \*\* No marking capacitor 1608 X7R SMD

N.C POINT : C9065

	MODEL NAME	SCALE	DESIGNER
	PD55B2_BHS	A3	S.K. YOO
	REV R.E		T.H.KANG
	BN44-00428B		S.K. HWANG