

High Performance Digital FM Transmitter for Portable Devices

General Description

The QN8027 is a high performance, low power, full-featured single-chip stereo FM transmitter designed for portable audio/video players, automotive accessories, cell phones, and GPS personal navigation devices. The QN8027 covers frequencies from 76 MHz to 108 MHz in 50/100/200 kHz step sizes for worldwide FM band support. The QN8027 also supports RDS/RBDS data transmit.

The QN8027 integrates a complete transmitter function, from stereo audio input to RF antenna port, for worldwide FM band personal area broadcasting. It includes variable input gain programming, selectable pre-emphasis, precision low-spur MPX stereo encoding and pilot tone generation, low-noise PLL-based modulation, and an on-chip power amplifier with variable output level and RF band-pass filtering to ensure optimum transmit spectrum purity.

An integrated crystal oscillator and on-chip digital calibration circuits eliminate external tuning components and enable tuning-free manufacturing. Support for 12/24MHz reference clocks allow the chip to use readily available system clocks. Integrated saturation detection and a programmable audio interface eliminate distortion, optimize audio fidelity, and support a wide range of input audio levels. A low power IDLE mode extends battery life. An integrated LDO enables direct connection to the battery and provides high PSRR for superior noise suppression, in particular TDMA noise from GSM/GPRS phones.

The QN8027's small footprint, high integration with minimum external component count, and support for 12/24MHz clock frequencies make it easy to integrate into a variety of small form-factor low-power portable applications. Integrated low-phase noise digital synthesizers and extensive on-chip auto calibration ensures robust consistent performance over temperature and process variations. An integrated voltage regulator enables direct connection to a battery and provides high PSRR for superior noise suppression. A low-power IDLE mode extends battery life.

ESD protection is on all pins. The QN8027 is fabricated in highly reliable CMOS technology.

Key Features

- **Worldwide FM Band Transmit**
 - 76 MHz to 108 MHz full band tuning in 50/100/200 kHz step sizes
 - 50/75 μ s pre-emphasis
- **Ease of Integration**
 - Small footprint, 3 x 3 x 0.95mm MSOP10
 - Only 2 external passive components required
 - Adaptive antenna tuning
 - Low cellular and GPS band spurs
 - High Immunity to TDMA (GSM/GPRS) burst noise
 - Multiple crystal frequencies supported
 - I²C interface
- **Low Power Consumption**
 - 7.0 mA of FCC output level
 - Integrated voltage regulator, direct connect to battery
 - Power saving IDLE-mode
- **High Performance FM Transmitter (FMT)**
 - 65dB Stereo SNR, 0.04% THD
 - Maximum 119 dB μ Vp RF output level with 34dB adjustable range
- **Automatic Input Audio Sensing**
 - RF power automatically turned off if no input audio signal for 60s
- **RDS/RBDS Transmit**
 - Supports US and European data service, including TMC (Traffic Messaging Channel)
- **Robust Operation**
 - -25^oC to +85^oC operation
 - ESD protection on all input and output pads

Typical Applications

- Cell Phones / PDAs / Smart Phones
- Portable Audio & Media Players
- GPS Personal Navigation Devices
- Automotive and Accessories

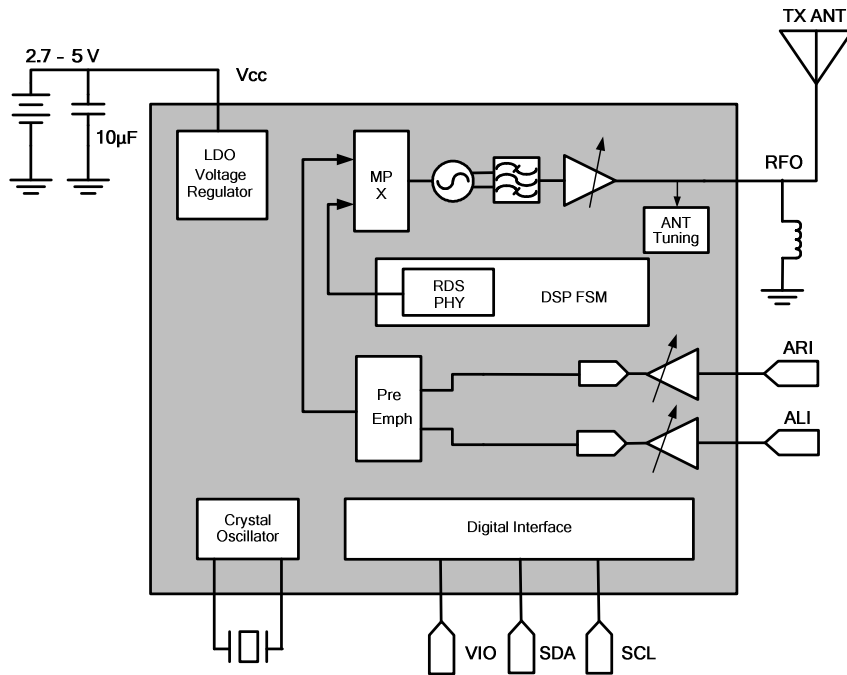

QN8027-SANC Block Diagram

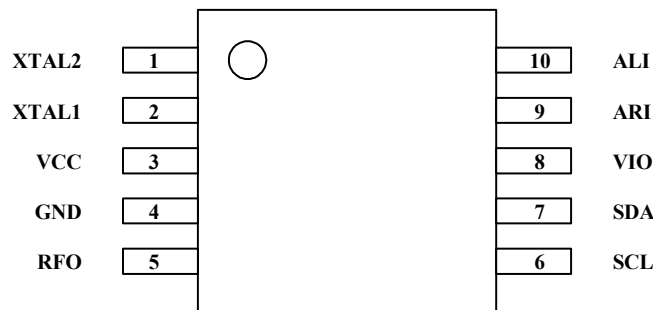

QN8027-SANC Pin out MSOP10

CONTACT INFORMATION

Quintic Corporation (USA)
 3211 Scott Blvd, Suite 203
 Santa Clara, CA 95054
 Tel: +1 408 970-8808
 Fax: +1 408 970-8829
 Email: support@quinticcorp.com
 Web: www.quinticcorp.com

Quintic Microelectronics (China)
 Building 8 B-301A Tsinghua Science Park
 1st East Zhongguancun Rd, Haidian
 Beijing, China 100084
 Tel: +86 (10) 8215-1997
 Fax: +86 (10) 8215-1570
 Email: support@quinticcorp.com
 Web: www.quinticcorp.com

Quintic Microelectronics and Quintic are trademarks of Quintic Corporation. All Rights Reserved.