

NOTES: UNLESS OTHERWISE SPECIFIED

- CONSTRUCTION: MOLDED NYLON ZYTEL 101L HOUSING & PLUNGER: 10/11% GLASS FILLED. COMPRESSION SPRING: STAINLESS STEEL 302, .009" DIA. WIRE PASSIVATED. CONTACT BLADE: STAINLESS STEEL, 304 FULL HARD. PASSIVATED PER MIL-S-5002 TYPE 1.

2. FEATURES:

HOOK CONNECTS TO 0.065" [1.65] DIA WIRE OR SMALLER. DOUBLE GRIPPER IS DESIGNED FOR HARD TO MAKE TEST CONNECTIONS OF VARYING SIZES AND SHAPES. DOUBLE HOOKS ASSURE SOLID CONTACT WITH EASY TO USE SPRING LOADED DESIGN. NARROW BODY CONFIGURATION IDEAL FOR SIDE BY SIDE STACKING OF MULTIPLE CONNECTORS. SQUARE PINS EXIT PLUNGER ON EITHER SIDE AND PERMIT CONNECTION TO .025" [0.64] SQ. OR 0.030" [0.76] DIA. SKT.

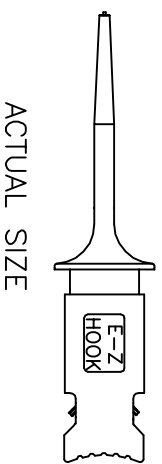
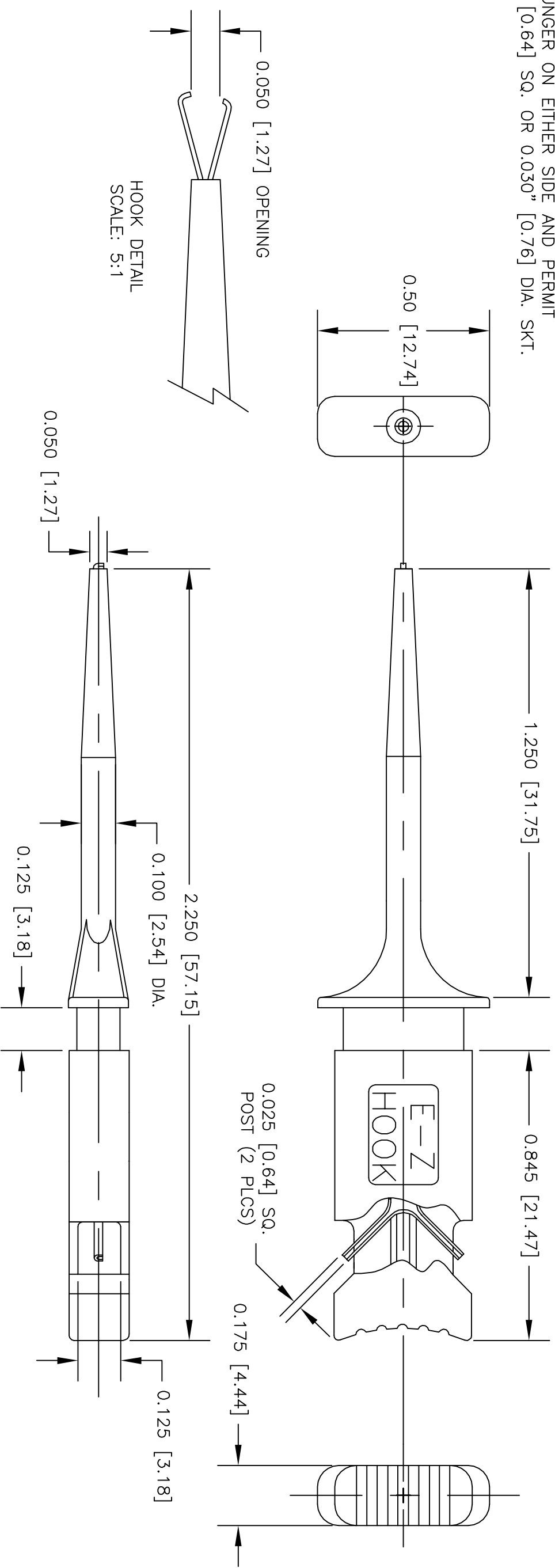

UNLESS OTHERWISE SPECIFIED DIMENSIONS ARE IN INCHES TOLERANCES ARE: FRACTIONS DECIMALS ANGLES		CONTRACT NO.		DESCRIPTION	
± .XX ±	± .XXX ±	APPROVALS	DATE	<b>E-Z-HOOK</b> DIVISION OF TEKTEST INC. ARCADIA, CA 91006 U.S.A. E-Z-MICRO HOOK GRIPPER TEST CONNECTOR	
±	±	DRAWN	6/09		
MATERIAL SEE NOTE.		APPROVED BY		SIZE	CODE IDENT NO. DRAWING NO.
FINISH SEE NOTE.				B	08505 XKMCOLOR
DO NOT SCALE DRAWING				SCALE	3:1
				SHEET	1 OF 1
				REV	