

# JUNO-G JUNO-G(J)

## SERVICE NOTES Issued by RJA

**128 VOICE EXPANDABLE SYNTHESIZER**  
with AUDIO/MIDI Song Recorder

### Table of Contents

Cautionary Notes .....	2	Circuit Board (MAIN Board: 1/2).....	24
Specifications .....	2	Circuit Board (MAIN Board: 2/2).....	25
Location of Controls/Location of Controls Parts List .4		Circuit Board (JACK, PANEL-C, LCD Board: 1/2)....	26
Exploded View (1).....	6	Circuit Board (JACK, PANEL-C, LCD Board: 2/2)....	27
Exploded View (1) Parts List.....	7	Circuit Board (PANEL-A, B Board).....	28
Exploded View (2).....	8	Circuit Diagram (MAIN Board: 1/4).....	30
Exploded View (2) Parts List.....	9	Circuit Diagram (MAIN Board: 2/4).....	32
Keyboard Parts List.....	10	Circuit Diagram (MAIN Board: 3/4).....	34
Parts List.....	11	Circuit Diagram (MAIN Board: 4/4).....	36
Wiring Diagram.....	14	Circuit Diagram (JACK Board: 1/2).....	38
Checking Version Number .....	15	Circuit Diagram (JACK Board: 2/2).....	40
Data Save (User Backup).....	15	Circuit Diagram (PANEL-A Board) .....	42
Data Load (User Restore).....	16	Circuit Diagram (PANEL-B Board) .....	44
Factory Reset.....	16	Circuit Diagram (PANEL-C Board: 1/2) .....	46
System Update.....	16	Circuit Diagram (PANEL-C Board: 2/2) .....	48
Test Mode.....	17	Error Messages .....	50
Block Diagram .....	23		

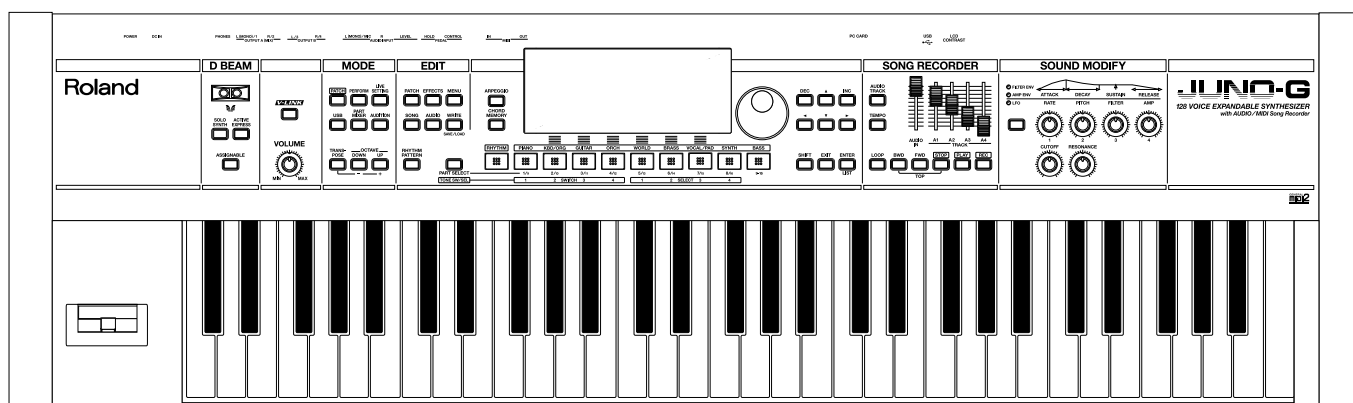

**Copyright © 2006 ROLAND CORPORATION**

All rights reserved. No part of this publication may be reproduced in any form without the written permission of ROLAND CORPORATION.

## Cautionary Notes

### User data status

User data status after each of the following processes is described below. Whenever carrying out procedures that involve deleting or erasing user data, always be sure to back up the user data to some form of external storage media. Refer to **Data Save (User Backup)** (p. 15).

Process	User Data
Checking Version number	Preserved
Factory Reset	Deleted
System Update	Deleted
Test Mode	Preserved

\* Executing Test Mode during Factory Reset deletes the user data.

### Parts List

Due to one or more of the following reasons, parts with parts code \*\*\*\*\* cannot be supplied as service parts.

- Part supplied only as a component in a complete assembly
- Copyright does not permit the part to be supplied
- Part is sold commercially

### Circuit Diagram

In the circuit diagram, 'NIU' is an abbreviation for 'NOT IN USE'.

The circuit board and circuit-board diagram show silkscreened indications, but no components are mounted.

## Specifications

JUNO-G: Synthesizer Keyboard (Conforms to General MIDI 2 System)

### Keyboard

61 keys (with velocity)

### ■ Sound Generator Section

#### Maximum Polyphony

128 voices (shared with audio track section)

#### Parts

16 parts

#### Wave Memory

64 M bytes (16-bit linear equivalent)

#### Preset Memory

Patches: 768 + 256 (GM2)

Rhythm Sets: 36 + 9 (GM2)

Performances: 64

#### User Memory

Patches: 256

Rhythm Sets: 32

Performances: 64

#### Effects

Multi-Effects: 3 systems, 78 types

Chorus: 3 types

Reverb: 5 types

Input Effects: 6 types

Mastering Effects: 3-band compressor

### ■ Song Recorder Section

#### Tracks

MIDI tracks: 16

Audio tracks: 4 stereo tracks

Tempo track: 1

Beat track: 1

#### Song Length

9998 measures

#### Tempo

5–300

#### MIDI Track

Resolution: 480 TPQN

Note Capacity: approx. 400,000 notes

Recording Method: Realtime recording, Step recording

## Audio Track

Data Format: 16-bit linear

Sample Rate: 44.1 kHz

Recording Time:

- memory not expanded (4 M bytes)  
approx. mono 47 seconds (stereo 23.5 seconds)
- memory fully expanded (516 M bytes)  
approx. mono 102 minutes (stereo 51 minutes)

## Others

### Arpeggiator

Preset: 128

User: 128

### Rhythm Pattern

Preset: 256 (32 groups)

User: 256 (32 groups)

### Chord Memory

Preset: 64

User: 64

## Controllers

D Beam Controller

Pitch Bend/Modulation Lever

Sound Modify Knob x 6

## Display

240 x 96 dots graphic LCD (with backlit)

## Expansion Slots

SRX expansion board: 1 slot

DIMM: 1 slot (memory expansion for audio recording)

## External Storage Device

PC Card: 1 slot

(supports SmartMedia and CompactFlash using a PC card adaptor)

## Connectors

Headphones Jack

Output Jacks (L (MONO), R): 1/4 inch phone type

Input Jacks (L (MONO)/MIC, R): 1/4 inch phone type

MIDI Connectors (IN, OUT)

Hold Pedal Jack

Control Pedal Jack

USB Connector (supports file transfer and MIDI)

## Power Supply

DC 9 V (AC Adaptor)

## Current draw

2000 mA

## Dimensions

1022.8 (W) x 298.4 (D) x 101.7 (H) mm

40-5/16 (W) x 11-3/4 (D) x 4-1/16 (H) inches

## Weight

6.2 kg / 13 lbs 11 oz (excluding AC Adaptor)

## Accessories

Owner's Manual English (#04232578)

CD-ROM (Editor/Librarian/USB MIDI driver) (#04349890)

CD-ROM (SONAR LE) (\*\*\*\*\*)

PC Card Protector (#04124301)

AC Adaptor (#03017356)

AC Cord Set (#02562456 for 117V U and 117V U/CS)

(#01903356 for 230V EU and 230V E)

(#03785590 for 240V A)

## Options

Wave Expansion Board: SRX Series

Keyboard Stand: KS-12

Pedal Switch: DP series

Foot Switch: BOSS FS-5U

Expression Pedal: EV-5

# Location of Controls/Location of Controls Parts List

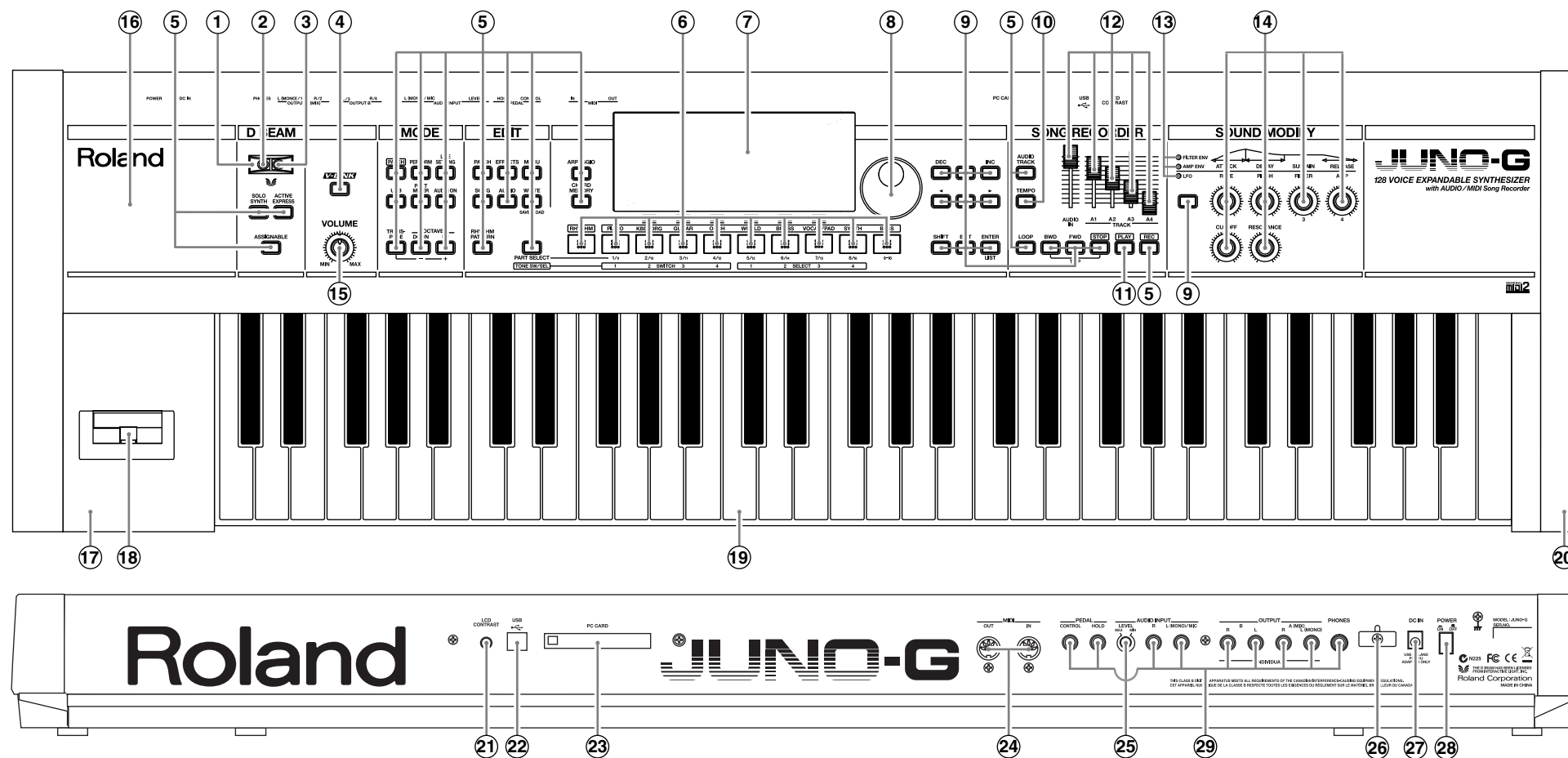

No.	Parts Code	Parts Name	Description	Q'ty	No.	Parts Code	Parts Name	Description	Q'ty
1	01343089	ESCUTCHEON	D-BEAM CONTROLLER ESCT BLK	1	13	00899023	LED	LNJ282RKRXE	3
2	03126134	LED (INFRARED)	TLN233 (F)	1	14	02455223	9M/M ROTARY POTENTIOMETER	EVUF2KFK4B14	6
3	01900612	DIODE	TPS611(F)	1	14	04124267	J R-KNOB	SF-ELA BLK/SLV	6
4	02891789	TACT SWITCH	SKRGADD010 H=5.0	1	15	02455234	12M/M ROTARY POTENTIOMETER	EVJY15F02B14	1
4	04348801	D S-KEYTOP	SX1H-B GRS	1	15	04124267	J R-KNOB	SF-ELA BLK/SLV	1
4	03893601	LED	SLR343BCT3F	1	16	04122867	TOP PANEL		1
5	01904112	LED (RED)	SLR-342VCT32 N.P.Q RANK	25	17	04124223	SIDE PANEL L		1
5	02891789	TACT SWITCH	SKRGADD010 H=5.0	25	18	03234723	BENDER	PB-H0204	1
5	04348801	D S-KEYTOP	SX1H-B GRS	25	19	04344189	KEYBOARD ASSY	MSK-2 61KEY (W/O CABLE)	1
6	01904112	LED (RED)	SLR-342VCT32 N.P.Q RANK	10	20	04124234	SIDE PANEL R		1
6	02891789	TACT SWITCH	SKRGADD010 H=5.0	10	21	04128767	POTENTIOMETER	RK09K1110AFG	1
6	04124312	N S-KEYTOP	MD1H BLK MNP	10	22	02781189	USB CONNECTOR B TYPE FEMALE	YKF45-0021	1
7	04010634	LCD		1	23	01343545	CONNECTOR	SCAA1A0900	1
7	04128778	DISPLAY COVER		1	23	02900867	CARD EJECTOR	SCAB1A5600	1
8	03122134	ROTARY ENCODER	EC12E2420802	1	23	04124290	PC CARD ESCUTCHEON	BLK MNP	1
8	04128090	D R-KNOB	L-ELA MNP	1	24	13429825	MIDI CONNECTOR	YKF51-5054V	2
9	02891789	TACT SWITCH	SKRGADD010 H=5.0	13	25	02781390	9M/M ROTARY POTENTIOMETER	RK09K12A0D0S 20KAX2	1
9	04348801	D S-KEYTOP	SX1H-B GRS	13	26	04451556	CORD HOOK MNP		1
10	01239867	LED (RED/GREEN) CLR	SML72423C TP15	1	27	13449711	AC ADAPTOR JACK	HEC0470-01-630 (for JUNO-G (J)) * equivalent to #13449720	1
10	02891789	TACT SWITCH	SKRGADD010 H=5.0	1	27	13449720	DC JACK	HEC2305-01-250 (for JUNO-G) * equivalent to #13449711	1
10	04348801	D S-KEYTOP	SX1H-B GRS	1	28	01676512	PUSH SWITCH	SDKLA10200	1
11	02454278	LED	SLR-322MC-T32	1	28	12499175	BUTTON	JSPUE0011A	1
11	02891789	TACT SWITCH	SKRGADD010 H=5.0	1	29	00569278	6.5MM JACK	LGR4609-7000	9
11	04348801	D S-KEYTOP	SX1H-B GRS	1					
12	04124278	S-KNOB	SLV	5					
12	04233478	SLIDE POTENTIOMETER	30M/M RS30111AC019	5					

# Exploded View (1)

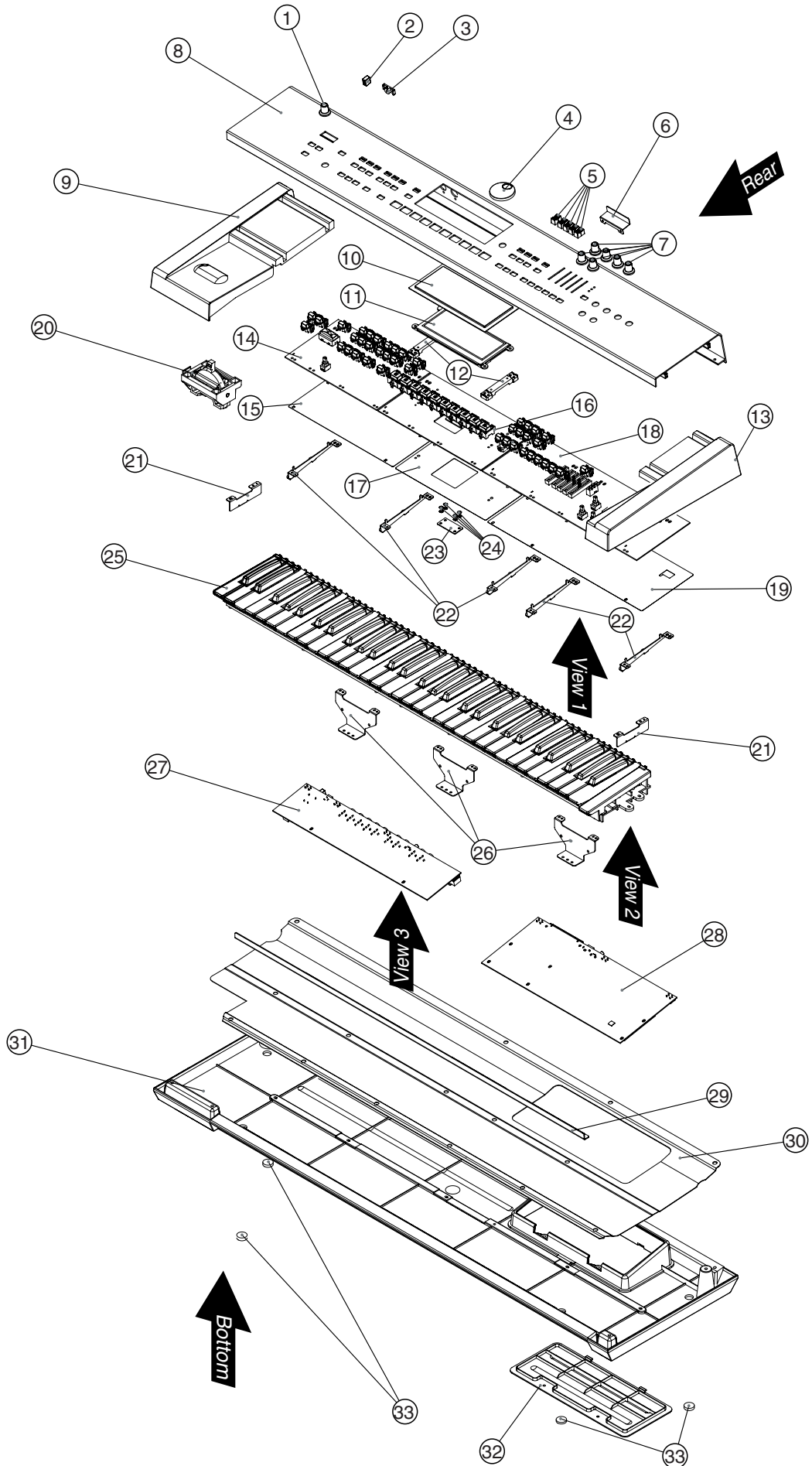

## Exploded View (1) Parts List

No.	Parts Code	Parts Name	Description	Q'ty
1	04124267	J R-KNOB	SF-ELA BLK/SLV	1
2	01676512	PUSH SWITCH	SDKLA10200	1
3	04451556	CORD HOOK MNP		1
4	04128090	D R-KNOB	L-ELA MNP	1
5	04124278	S-KNOB	SLV	5
6	04124301	PROTECTOR PC CARD		1
7	04124267	J R-KNOB	SF-ELA BLK/SLV	6
8	04122867	TOP PANEL		1
9	04124223	SIDE PANEL L		1
10	04128778	DISPLAY COVER		1
11	04010634	LCD		1
12	04124256	LCD HOLDER		2
13	04124234	SIDE PANEL R		1
14	04231889	PANEL-A BOARD ASSY		1
15	04235178	INSULATING SHEET	FOR PANEL-A BOARD	1
16	04231890	PANEL-B BOARD ASSY		1
17	04235189	INSULATING SHEET	FOR PANEL-B BOARD	1
18	73342067	PANEL-C BOARD ASSY JAPAN	equivalent to #04231923	1
19	04235190	INSULATING SHEET	FOR PANEL-C BOARD	1
20	03234723	BENDER	PB-H0204	1
21	03671278	METAL HOLDER	FOR SIDE PANEL	2
22	04124334	PWB HOLDER		5
23	73342078	LCD BOARD ASSY		1
24	00673067	PWB SPACER	WLS-04-0	4
25	04344189	KEYBOARD ASSY	MSK-2 61KEY (W/O CABLE)	1
25	04344201	CABLE ASSY	FOR MSK-2	1
26	04124323	PANEL HOLDER		3
27	73342089	JACK BOARD ASSY JAPAN	equivalent to #04231934	1
28	73342090	MAIN BOARD ASSY JAPAN	equivalent to #04231867	1
29	03671290	REINFORCE BAR		1
30	04129323	SHIELD SHEET		1
31	04124212	BOTTOM CASE		1
32	04124245	EXPANSION COVER		1
33	12359137	RUBBER FOOT	SJ-5012 BLK	4

# Exploded View (2)

View 1

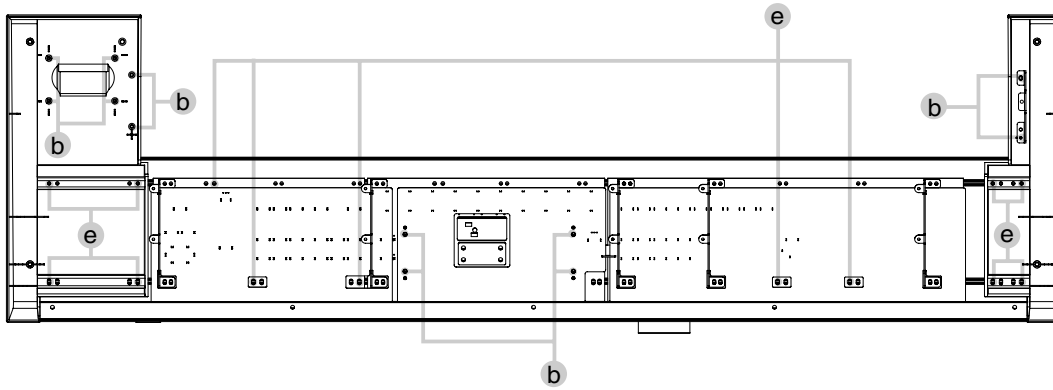

View 2

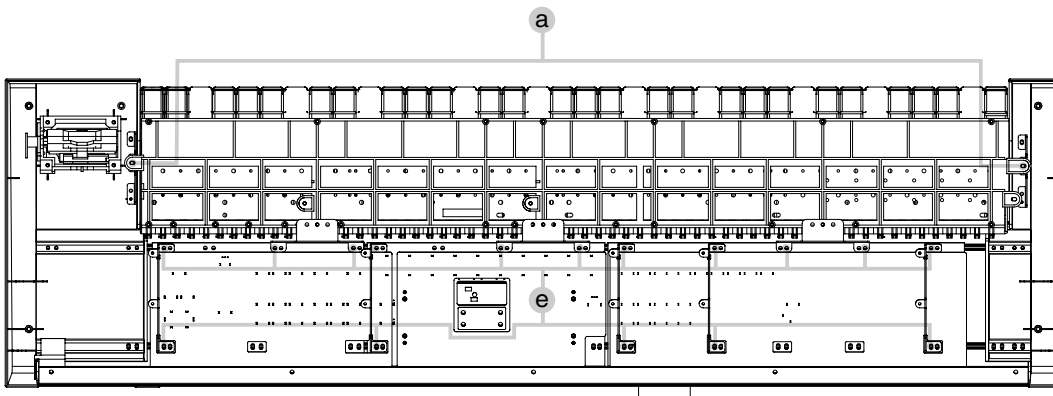

View 3

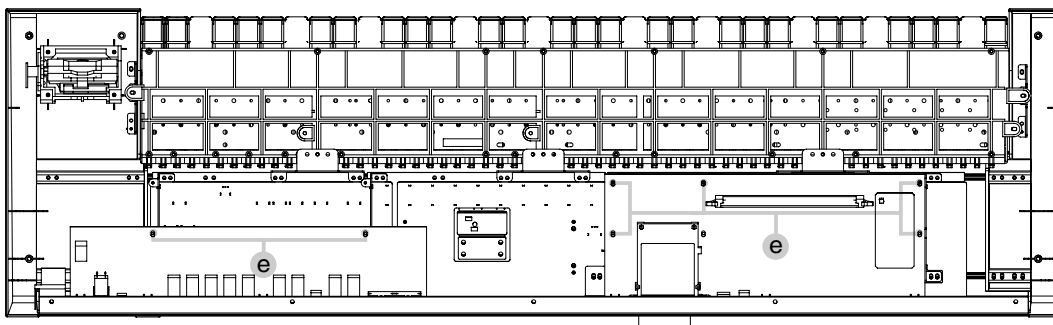

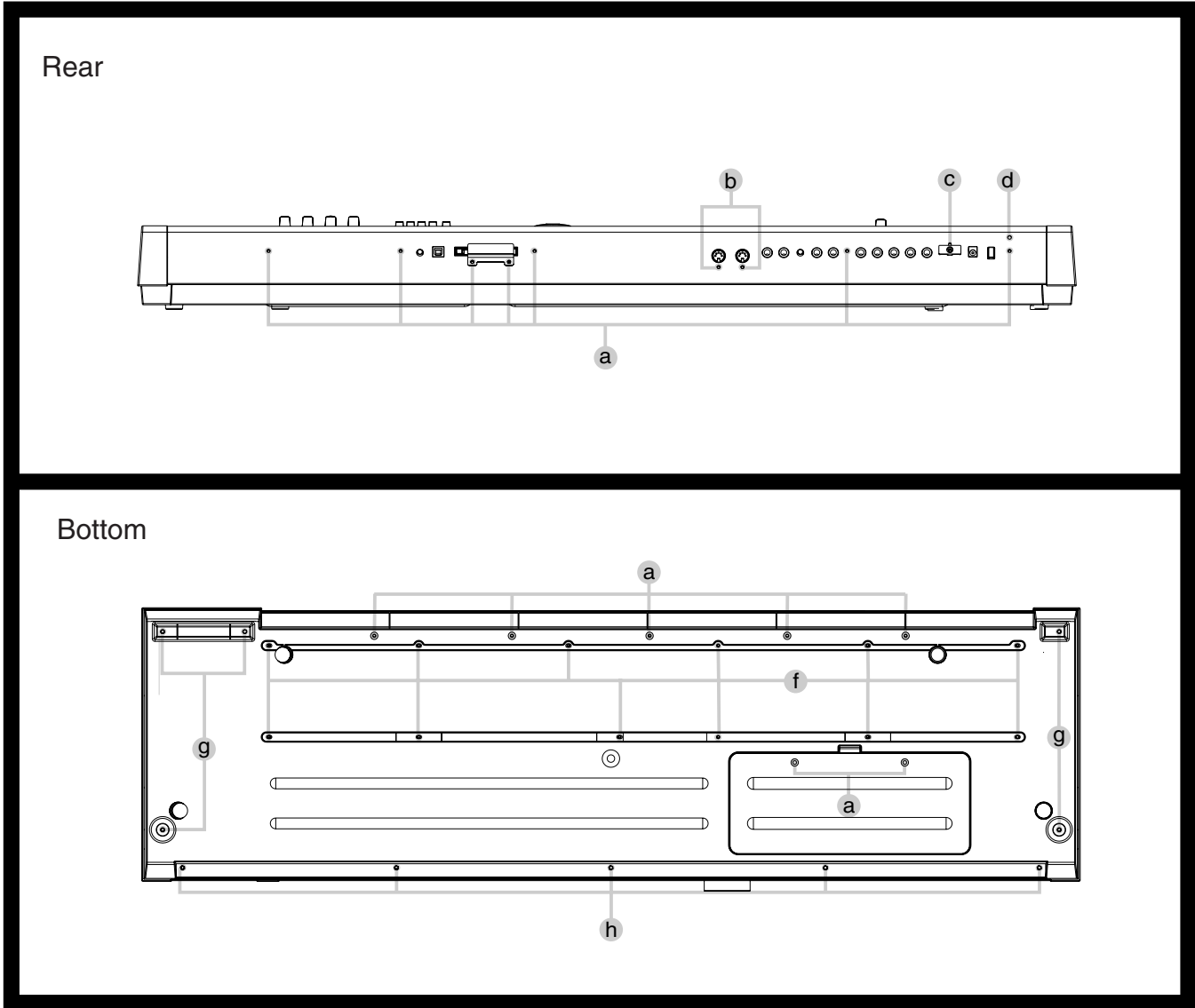

## Exploded View (2) Parts List

No.	Parts Code	Parts Name	Description	Q'ty
a	40012956	SCREW M3X8	PAN MACHINE W/SW+PW FE BZC	16
b	40011312	SCREW 3X8	BINDING TAPTITE P BZC	14
c	40340812	SCREW M3X10	PAN MACHINE W/SW BZC	1
d	40454856	SCREW M4X10	BINDING NI	1
e	40011101	SCREW 3X8	BINDING TAPTITE B BZC	35
f	40011334	SCREW 3X12	BINDING TAPTITE-P FE BZC	12
g	40012501	SCREW M4X12	BINDING TAPTITE P FE BZC	5
h	40011123	SCREW 4X8	BINDING TAPTITE B BZC	5



# Keyboard Parts List

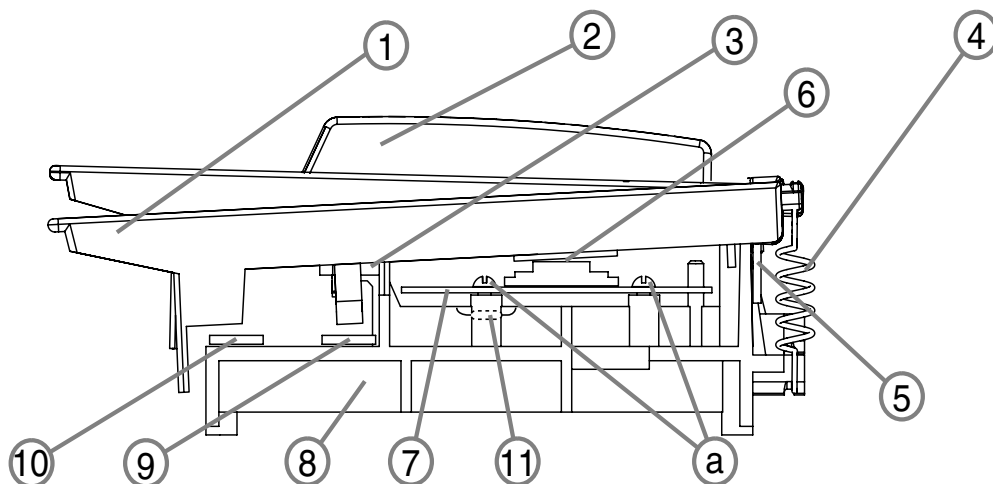

No.	Part Code	Part Name	Description	Q'ty
1	03786378	NATURAL KEY C	FOR MSK-2	5
1	03786389	NATURAL KEY D	FOR MSK-2	5
1	03786390	NATURAL KEY E	FOR MSK-2	5
1	03786401	NATURAL KEY F	FOR MSK-2	5
1	03786412	NATURAL KEY G	FOR MSK-2	5
1	03786423	NATURAL KEY A	FOR MSK-2	5
1	03786434	NATURAL KEY B	FOR MSK-2	5
1	03786445	NATURAL KEY C'	FOR MSK-2	1
2	03786456	SHARP KEY	FOR MSK-2	25
3	03786312	KEY FELT	MSK-2 HOOK T2.0MM L828XW5.5	1
4	03456967	COILED SPRING	MSK-1 NATURAL KEY	36
4	03456978	COILED SPRING	MSK-1 SHARP KEY	25
5	03786301	KEY FELT	MSK-2 BACK T4.0MM L840XW6.0	1
6	03456856	RUBBER SW KEYBOARD 12P	FOR MSK-1	4
6	03456867	RUBBER SW KEYBOARD 13P	FOR MSK-1	1
7	03786345	PWB KEYBOARD LO ASSY	FOR MSK-2	1
7	03786356	PWB KEYBOARD HI ASSY	FOR MSK-2	1
8	*****	CHASSIS KEYBOARD	FOR MSK-2	1
9	03786334	KEY FELT	MSK-2 BOTTOM M T2.0MM L840XW10	1
10	03786323	KEY FELT	MSK-2 BOTTOM L T2.0MM L840XW15	1
11	15019126	SWITCHING DIODE	1SS133 T-77	122
a	40011189	SCREW 3X8	PAN TAPTITE-P FE ZC	34

# Parts List

CASING				
	01343089	ESCUTCHEON	D-BEAM CONTROLLER ESCT BLK	1
#	04124290	PC CARD ESCUTCHEON	BLK MNP	1
#	04124212	BOTTOM CASE		1
#	04128778	DISPLAY COVER		1
#	04124245	EXPANSION COVER		1
#	04124223	SIDE PANEL L		1
#	04124234	SIDE PANEL R		1
#	04122867	TOP PANEL		1
CHASSIS				
	03671278	METAL HOLDER	FOR SIDE PANEL	2
#	04124256	LCD HOLDER		2
#	04124323	PANEL HOLDER		3
#	04124334	PWB HOLDER		5
	03671290	REINFORCE BAR		1
KNOB, BUTTON				
#	04348801	D S-KEYTOP	SX2H-B GRS MNP	9
#	04124278	S-KNOB	SLV	5
	04124267	J R-KNOB	SF-ELA BLK/SLV	6
#	04124312	N S-KEYTOP	MD1H BLK MNP	1
#	04128090	D R-KNOB	L-ELA MNP	1
	12499175	BUTTON	JSPUE0011A	1
SWITCH				
	02891789	TACT SWITCH	SKRGADD010 H=5.0	1
	01676512	PUSH SWITCH	SDKLA10200	1
JACK, EXT TERMINAL				
	13429825	MIDI CONNECTOR	YKF51-5054V	1
	02781189	USB CONNECTOR B TYPE FE- MALE	YKF45-0021	1
	02900867	CARD EJECTOR	SCAB1A5600	1
	01343545	CONNECTOR	SCAA1A0900	1
	00569278	6.5MM JACK	LGR4609-7100F	1
	13449711	AC ADAPTOR JACK	HEC0470-01-630	1
	13449720	DC IN JACK	HEC2305-01-250	1
			for JUNO-G (J) (equivalent to #13449720)	
			for JUNO-G (equivalent to #13449711)	
DISPLAY UNIT				
#	04010634	LCD		1
BENDER UNIT				
	03234723	BENDER	PB-H0204	1
KEYBOARD ASSY				
#	04344189	KEYBOARD ASSY	MSK-2 61KEY (W/O CABLE)	1
#	04344201	CABLE ASSY	FOR MSK-2	1
		* KEYBOARD ASSY and CABLE ASSY need to be ordered separately.		
PWB ASSY				
#	73342078	LCD BOARD ASSY		1
#	73342089	JACK BOARD ASSY JAPAN	equivalent to #04231934	1
#	73342090	MAIN BOARD ASSY JAPAN	equivalent to #04231867	1
#	04231889	PANEL-A BOARD ASSY		1
#	04231890	PANEL-B BOARD ASSY		1
#	73342067	PANEL-C BOARD ASSY JAPAN	equivalent to #04231923	1
DIODE				
	01900612	DIODE	TPS611(F)	1
	03126134	LED(INFRARED)	TLN233(F)	1
	01239867	LED (RED/GREEN)CLR	SML72423C TP15	1
	03893601	LED	SLR343BCT3F	1
	01904112	LED(RED)	SLR-342VCT32 N.P.Q RANK	1
	02454278	LED	SLR-322MC-T32	1
	00899023	LED	LNJ282RKRXE	1

<b>DIODE</b>					
	15019126	SWITCHING DIODE	1SS133 T-77	D1, D2, D3, D4, D5, D6, D7, D8, D9, D10, D11, D12, D13, D14, D15, D16, D17, D18, D19, D20, D21, D22, D23, D24, D25, D26, D27 on PANEL-A	39
				D28, D29, D30, D31, D32, D33, D34, D35, D36, D37, D38, D39 on PANEL-B	
<b>POTENTIOMETER</b>					
	02781390	9M/M ROTARY POTENTIOMETER	RK09K12A0D0S 20KAX2		1
#	04128767	POTENTIOMETER	RK09K1110AFG		1
	02455223	9M/M ROTARY POTENTIOMETER	EVUF2KFK4B14		1
	02455234	12M/M ROTARY POTENTIOMETER	EVJY15F02B14		1
#	04233478	SLIDE POTENTIOMETER	30M/M RS30111AC019		1
<b>ENCODER</b>					
	03122134	ROTARY ENCODER	EC12E2420802		1
<b>CONNECTOR</b>					
	02010078	CONNECTOR	TX25-80P-6ST-E1	for CN10 on MAIN	1
	13369668	CONNECTOR	S8B-PH-K-S JST(LF/SN)(8P)	for CN2 on PANEL-A and CN13 on PANEL-C	2
	13369666	CONNECTOR	S6B PH-K-S(LF/SN)(6P)	for CN5 on PANEL-A	1
#	13369664	CONNECTOR	S4B-PH-K-S(LF/SN)(4P)	for CN15 on PANEL-C	1
	04126190	CONNECTOR	PS-26PE-D4T1-B1E	for CN6 on JACK	1
	03340289	CONNECTOR	B8B-PH-K-S (PB FREE)	for CN4 on MAIN and CN3 on JACK	2
	13369566	CONNECTOR	B6B-PH-K-S JST(LF)(SN)(6P)	for CN2 on JACK	1
	13369564	CONNECTOR	B12B-PH-K-S JST(LF)(SN)	for CN11 on MAIN and CN1 on JACK	2
	02458456	CONNECTOR	30FE-ST-VK-N	for CN3 on PANEL-B and CN12 on PANEL-C	2
	02122467	CONNECTOR	24FE-ST-VK-N	for CN1 on PANEL-A and CN4 on PANEL-B	2
	02780734	CONNECTOR	18FMN-STK	for CN14 on PANEL-C and CN16, 17 on LCD	3
	02011956	CONNECTOR	18FMN-BTK	for CN12 on MAIN and CN4 on JACK	2
	02235467	CONNECTOR	14FMN-STK	for CN7 on PANEL-C	1
	02011912	CONNECTOR	14FMN-BTK	for CN13 on MAIN	1
	13369826	HEADER CONNECTOR	PS-26PE-D4T1-B1-K	for CN6 on JACK	1
<b>WIRING, CABLE</b>					
#	04344201	CABLE ASSY	FOR MSK-2	for KEYBOARD ASSY	1
#	04232501	BAN CARD	BNCD-P=1.25-K-30-170		1
#	04232490	BAN CARD	BNCD-P=1.25-K-24-150		1
#	04232456	BAN CARD	BNCD-P=1.00-K-18-700		1
#	04232489	BAN CARD	BNCD-P=1.00-K-18-200		1
#	04232478	BAN CARD	BNCD-P=1.00-K-14-500		1
	02343645	WIRING	8X650-P2.0-PHR-PHR-F		1
	02343623	WIRING	8X550-P2.0-PHR-PHR-F		1
	02343234	WIRING	6X150-P2.0-PHR-PHR-F		1
	02342167	WIRING	4X900-P2.0-PHR-PHR-F		1
#	04232445	WIRING	12X900-P2.0-PHR-PHR-F		1
<b>SCREWS</b>					
	40343367	SCREW M2X14	PAN MACHINE W/SW+SMALL PWZC		1
	40012956	SCREW M3X8	PAN MACHINE W/SW+PW FE BZC		16
	40340812	SCREW M3X10	PAN MACHINE W/SW BZC		1
	40011501	SCREW M3X8	PAN MACHINE W/SW BZC		1
	40011334	SCREW 3X12	BINDING TAPTITE-P FE BZC		12
	40011312	SCREW 3X8	BINDING TAPTITE P BZC		14
	40011101	SCREW 3X8	BINDING TAPTITE B BZC		35
	40011123	SCREW 4X8	BINDING TAPTITE B BZC		1
	40454856	SCREW M4X10	BINDING NI		1
	40011189	SCREW 3X8	PAN TAPTITE-P FE ZC	for Bender Unit	3
	40012501	SCREW M4X12	BINDING TAPTITE P FE BZC		5
<b>PACKING</b>					
#	04232534	PACKING PAD	SIDE R		1
#	04232523	PACKING PAD	SIDE L		1
#	04232545	PACKING PAD	CENTER		1
#	04232556	PACKING PAD	ADAPTOR		1
#	04232512	PACKING CASE			1

**MISCELLANEOUS**

	00673067	PWB SPACER	WLS-04-0		1
	40016534	INSULOK TIE 204M/M	T-18L		1
	12359137	RUBBER FOOT	SJ-5012 BLK		1
	01902756	PWB SPACER	RSPLS-12L		1
	02019034	PWB SPACER	RSPLS-12L		1
	40122812	ACETATE TAPE	NITTO NO.5 BLK W15MM 30M		1
	12199584	GROUNDING TERMINAL	M1698		1
	02230578	LED SPACER	LDS-50R		1
	12169368	LED SPACER	LDS-40B		1
#	04235190	INSULATING SHEET	FOR PANEL-C BOARD		1
#	04235189	INSULATING SHEET	FOR PANEL-B BOARD		1
#	04235178	INSULATING SHEET	FOR PANEL-A BOARD		1
	40120967	COATING CLIP	CS-3		6
#	04236390	LCD CUSHION	400MM		1
#	04450089	HEATSINK	PC1115-25-PB-SN	for JUNO-G (J) (equivalent to #04236412)	1
#	04236412	HEATSINK	25X15X11	for JUNO-G (equivalent to #04450089)	1
#	04236378	CUSHION	20X30X40		1
	40122556	DOUBLE FACED ADHESHIVE TAPE	#575X W30MM 30M 10P 30CM		1
	40122901	DOUBLE-FACED TAPE	#501F W10MM 20M 20P (CM)		1
	04451556	CORD HOOK MNP			1
	01343090	LED SPACER			1
#	04124301	PROTECTOR PC CARD			1
#	04129323	SHIELD SHEET			1

**ACCESSORIES (Standard)**

#	04232567	(HP)OWNER'S MANUAL	JAPANESE		1
#	04232578	OWNER'S MANUAL	ENGLISH		1
#	40674601	(HP)LEAFLET	CONTENTS LIST		1
#	04349890	CD-ROM EDITOR & DRIVER V1.01			1
	03017356	AC ADAPTOR WITHOUT AC CORD	PSB-1U(R) UNIVERSAL		1
	01903334	AC CORD SET PSE	100V 1.0M FOR PSB-1U	for 100V	1
	02562456	AC CORD SET	120V 1.0M (NON POLAR)	for 117V U, 117V U/C	1
	01903356	AC CORD SET	230V 1.0M FOR PSB	for 230V EU, 230V E	1
	00905234	EURO CONVERTER PLUG	ECP01-5A	for 230V E	1
	03785590	AC CORD SET	SC-078-NA05 240VA	for 240V A	1
	40232334	WARRANTY CARD	MOCHIKOMI JAPAN ONLY		1

# Wiring Diagram

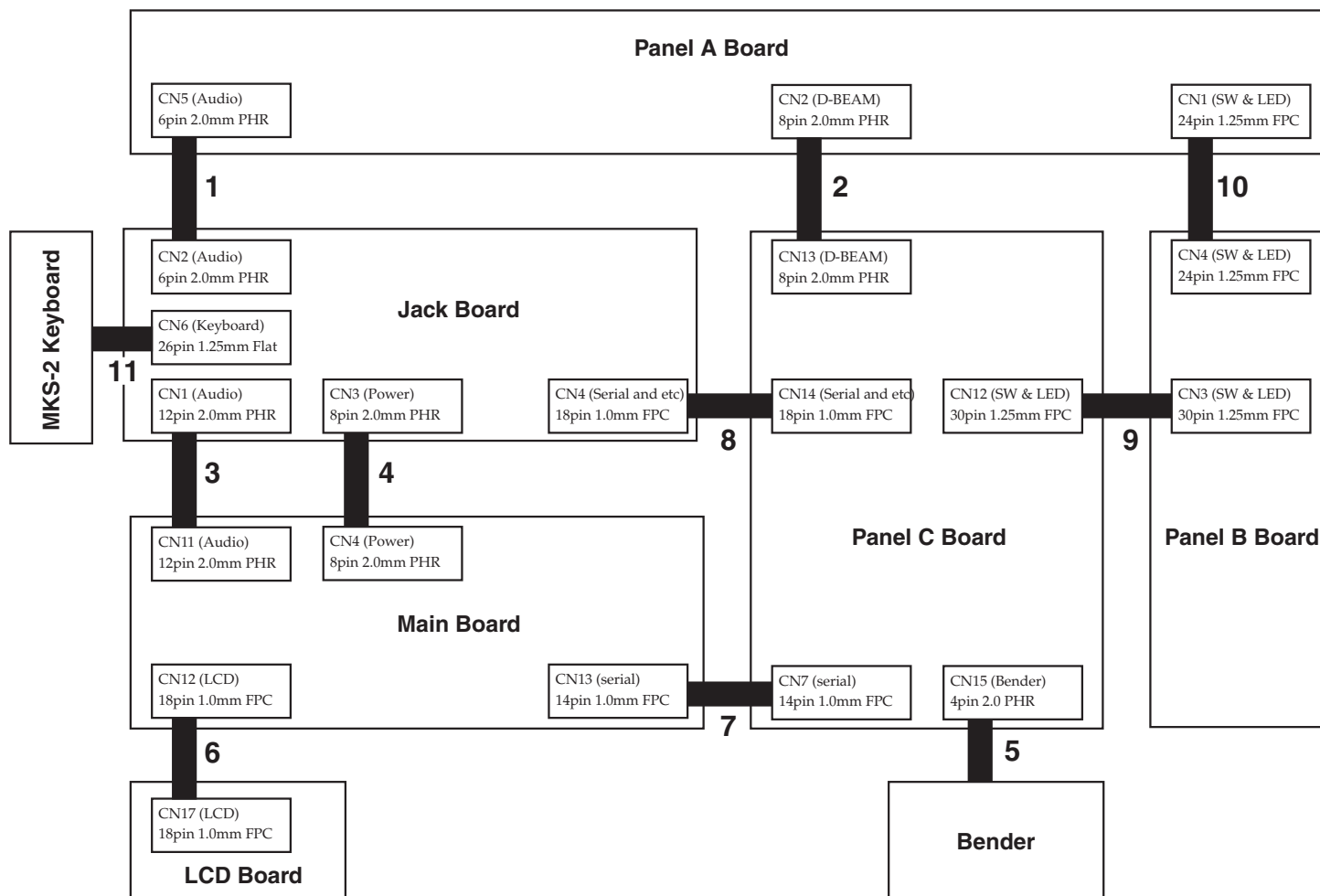

No.	Parts Code	Parts Name	Description
1	02343234	WIRING	6X150-P2.0-PHR-PHR-F
2	02343645	WIRING	8X650-P2.0-PHR-PHR-F
3	# 04232445	WIRING	12X900-P2.0-PHR-PHR-F
4	02343623	WIRING	8X550-P2.0-PHR-PHR-F
5	02342167	WIRING	4X900-P2.0-PHR-PHR-F
6	# 04232489	BAN CARD	BNCD-P=1.00-K-18-200
7	# 04232478	BAN CARD	BNCD-P=1.00-K-14-500
8	# 04232456	BAN CARD	BNCD-P=1.00-K-18-700
9	# 04232501	BAN CARD	BNCD-P=1.25-K-30-170
10	# 04232490	BAN CARD	BNCD-P=1.25-K-24-150
11	# 04344201	CABLE ASSY	FOR MSK-2

## Checking Version Number

1. Turn on the power of the JUNO-G.
2. Press the [MENU] button in EDIT section on the top panel.
3. Press [▲][▼] to select **2. System**, and press [ENTER].  
System Menu appears.



4. Press [F6 (INFORMATION)].  
SYSTEM INFO appears.

### MEMO

#### Function Buttons

Six buttons of [KBD/ORG]--[VOCAL/PAD] standing in the bottom of the screen work as buttons (Function Buttons) to select various functions. They are written like [F1]--[F6] in this document.

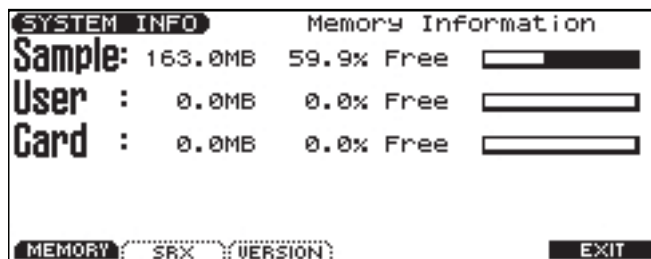

5. Press [F3 (VERSION)] to confirm the System Program version.



6. After confirming, press [EXIT] to return to PATCH PLAY screen.

## Data Save (User Backup)

Saves all of user data in the User Area to a memory card. User data which are saved by this procedure are as follows.

- Performances
- Patches
- Rhythm Sets
- Rhythm Patterns
- Rhythm Groups
- Arpeggio Styles
- Songs
- Samples
- Chord Forms
- System Settings

\* When executing User Backup, about 16 MB as the maximum free space is necessary in the memory card.

1. Insert a memory card into the slot.
2. Press [MENU] in EDIT to open Top Menu.
3. Press [▲][▼] to select **3. Utility**, and press [ENTER].  
UTILITY MENU appears.

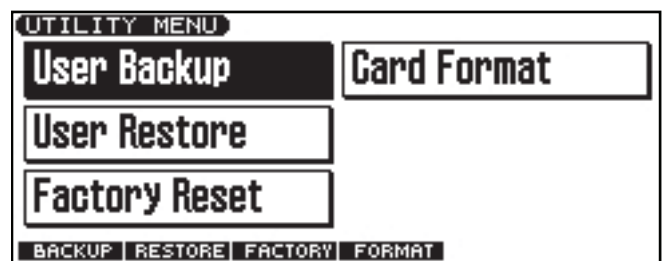

4. Press [F1 (BACKUP)].  
Confirming message appears.

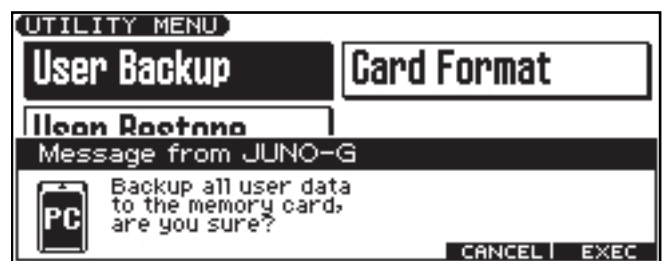

5. Press [F6 (EXEC)] to execute the backup.
6. Press [EXIT] to return to PATCH PLAY screen.

## Data Load (User Restore)

Restores the user data which have been saved in the memory card with the User Backup to User Area in JUNO-G.

\* All of contents in User Area will be erased after executing User Restore.

1. Insert the memory card in which user data have been saved.
2. Press [MENU] in EDIT to open Top Menu.
3. Press [ ▲ ] [ ▼ ] to select **3. Utility**, and press [ENTER].  
UTILITY MENU appears.

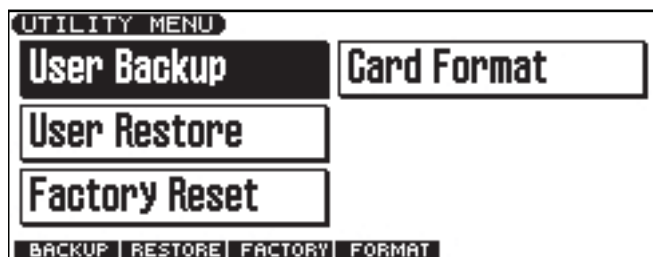

4. Press [F2 (RESTORE)].  
Confirming message appears.

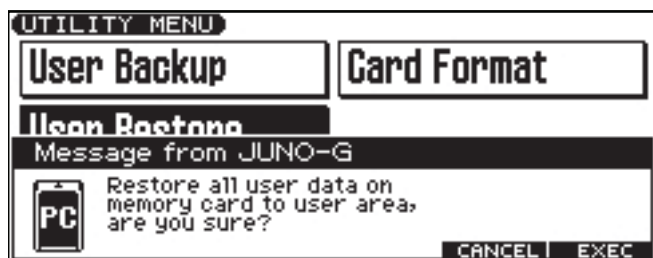

5. Press [F6 (EXEC)] to execute the restore.
6. After the message "Completed. Turn the Power off and on again." appears, turn off and on the power of the JUNO-G.

## Factory Reset



All data in User Area will be lost after executing Factory Reset. If the data which should not be lost are left in the JUNO-G, save them in memory card by User Backup function. Refer to **Data Save (User Backup)** (p. 15).



Never turn off the power while executing Factory Reset. Contents of memory may be lost.

1. Press [MENU] in EDIT to open Top Menu.
2. Press [ ▲ ] [ ▼ ] to select **3. Utility**, and press [ENTER].  
UTILITY MENU appears.

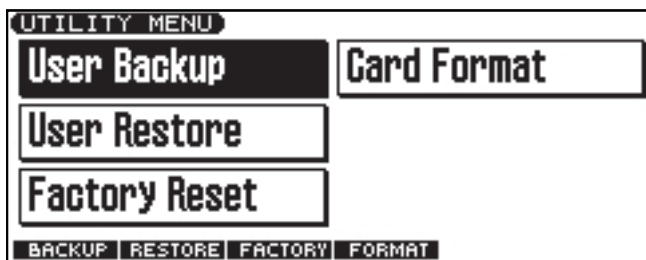

3. Press [F3 (FACTORY)].  
Confirming message appears.

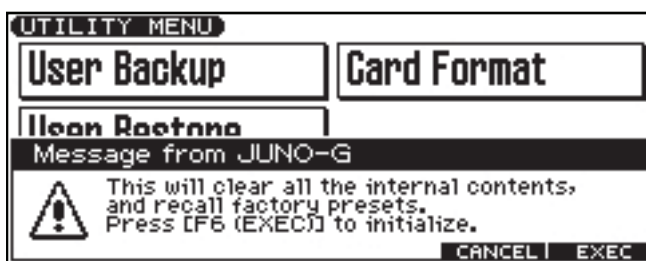

4. Press [F6 (EXEC)] to execute Factory Reset.
5. After the message "Completed. Turn the Power off and on again." appears, turn off and on the power of the JUNO-G.

## System Update



Before executing System Update, save data in the User Memory to memory card by User Backup function. Refer to **Data Save (User Backup)** (p. 15).

## Required Items

- JUNO-G
- UPDATE CD-ROM (#17041856)
- Memory Card x 2 (1 GB or less, for updating and for backup of User Data)
- PC (with a CD-ROM drive and a memory card reader/writer, OS: Windows Me/2000/XP)

\* Don't use Macintosh.

## Update Procedure

1. Save the data in User Memory to a memory card. Refer to **Data Save (User Backup)** (p. 15).
2. Boot up the PC, and insert the UPDATE CD-ROM and a memory card which is not used in step 1.
3. Format the memory card by the PC.
4. Copy the "Roland" folder with its contents in the UPDATE CD-ROM to the memory card.
5. Release the connection of the PC and the card reader/writer by device eject button shown in the taskbar at the lower right of the PC screen.
6. Remove the memory card from the card reader/writer.

7. Insert the memory card to the JUNO-G which power is turned off.
8. Turn on the power of the JUNO-G.  
Updating starts automatically.  
When message "-- Completed!" appears in the screen, updating is completed.
9. Remove the memory card and turn off and on the power.

## Work after Updating

1. After System Update, execute **Checking Version Number** (p. 15) and **Test Mode** (p. 17).
2. Restore the data which were saved in User Memory by step 1 in **Update Procedure** (p. 16). Refer to **Data Load (User Restore)** (p. 16).

## If You Made a Mistake on Updating

- Turn off the power of the JUNO-G and operate from the beginning again.
- If the updating still cannot be successful, exchange the MAIN Board.

## Test Mode

### NOTE

All data in User Area will be lost after executing Test Mode. If the data which should be saved are left in the JUNO-G, save them in memory card by User Backup function. Refer to **Data Save (User Backup)** (p. 15).

### NOTE

Procedure of JUNO-G Test Mode is different between ver. 1.01 or before and ver. 1.02 or later. This service notes explains procedure for ver. 1.02 or later. Check the version (**Checking Version Number** (p. 15)), and if the version is 1.01 or before, then update to ver. 1.02 or later before executing Test Mode. (**System Update** (p. 16))

## Required Items

- JUNO-G
- Memory Card (equal or less than 1GB)
- Memory (DIMM: 128--512 MB)
- Wave Expansion Board: SRX series
- Expression Pedal (e. g. EV-5)
- Headphones
- Noise Meter
- PC (with USB connector, OS: Windows Me/2000/XP)
- USB Cable x 1
- MIDI Cable x 1
- Audio Cable x 4 or 6
- Monitor Speaker
- Oscillator
- Oscilloscope

## Preparation of Test

1. Turn off the power of JUNO-G.
2. Remove the cover on the bottom and set the memory (DIMM) and the SRX.
3. Turn on the power of the JUNO-G and execute the Factory Reset. (**Factory Reset** (p. 16))
4. After completing the Factory Reset, turn off and on the power of the JUNO-G.
5. Now, boot up the PC for the test of **14. USB** (p. 21).

## Entering Test Mode

1. Press [MENU] in EDIT.
2. Press [▼] to select **2. System**, and press [ENTER].  
System Menu appears.



3. Press [F6 (INFORMATION)].  
SYSTEM INFO appears.

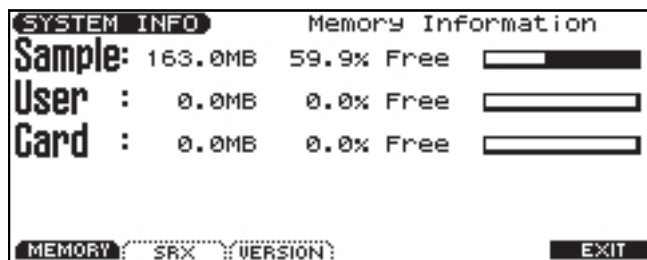

4. Press [SHIFT], [F4 (WORLD)], [F5 (BRASS)] and [ENTER] one by one in this order.  
Test Mode starts.

\* If you make a mistake in the order, turn off and on the power of the JUNO-G and retry from the step 1.

## Exiting Test Mode

Turn off the power of the JUNO-G.



## Test Items

In Test Mode, there are eighteen test items as follows.

1. Version Check
2. Device
3. DIMM
4. Expansion Board
5. Card
6. Encoder
7. Switch & LED
8. Switch2
9. LCD
10. AD
11. Mute
12. MIDI
13. Sound
14. USB
15. D Beam
16. Keyboard
17. Noise
18. Factory Reset

## Selecting Test Items

1. Press [MENU] in EDIT to display **Line Test Menu**.
2. Select test items by rotating VALUE dial or pressing [INC] [DEC] or [ ▲ ] [ ▼ ].
3. Press [ENTER] to execute the test.

## Skipping Test Items

When a test item finishes, basically, the test program advances to the next test item automatically. When the test is **NG**, however, the test program will not advance to the next automatically.

In that case, skip the test item by force with the following operations.

[SHIFT] + [ ► ]: Moves to the next test item by force.

[SHIFT] + [ ◀ ]: Moves to the previous test item by force.

## Details for Test Items

### 1. Version Check

Program version number appears in the screen.

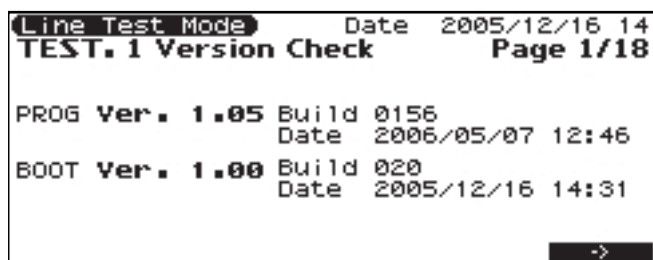

Press the [F6] button to advance to the next test item.

### 2. Device

Checks every device.

The following messages appears in the screen and nine test items are automatically executed.

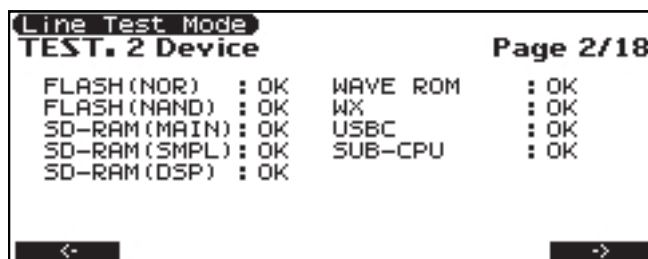

If the all is OK, the test program advances to the next test item automatically.

If there are any problems, **NG** indicates that point---the test program will not advance to the next items automatically.

Items in Screen	Correspond Devices
FLASH (NOR)	IC2
FLASH (NAND)	IC25
SD-RAM (MAIN)	IC3, IC6
SD-RAM (SMPL)	IC41, IC45
SD-RAM (DSP)	IC49
WAVE ROM	IC67
WX	IC43
USBC	IC26
SUB-CPU	JACK SHEET IC13

### 3. DIMM

Checks sockets of DIMMs and the peripheral circuit.

When entering the DIMM test, the following message appears in the screen and the DIMM test starts automatically.

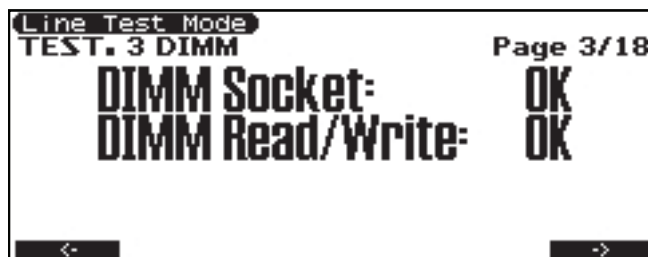

When the test finishes without problem, the test program advances to the next items automatically.

### 4. Expansion Board

Checks sockets of the Expansion Board and the peripheral circuit.

When entering the Expansion Board test, the name of the Expansion Board which is inserted appears in the screen.



After checking the name, press the keys to check whether correct tones in the Expansion Board sound or not.

After checking the tones, press the [F6] button to advance to the next test item.

(If no key were pressed, when the [F6] button are pressed, the test program doesn't advance to the next test item.)

### 5. Card

Checks connectors of the PC card and the peripheral circuit.  
When entering the Card test, the following message appears in the screen.

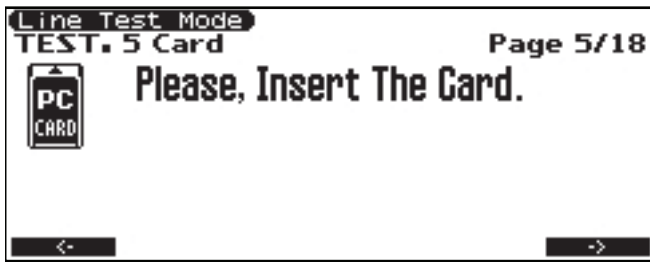

Insert the PC card prepared previously to the card slot.  
If the test is passed, the following message appears.

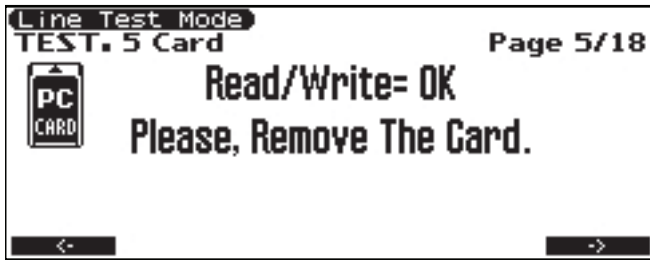

When removing the PC card, the test program advances to the next test item automatically.

### 6. Encoder

When entering the Encoder test, the following message appears in the screen.

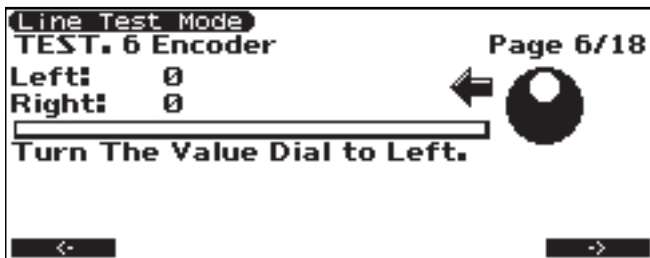

Rotate the VALUE dial counterclockwise for a while, and confirm the **Left: 72 OK** message appears in the screen.

Next, rotate the VALUE dial clockwise for a while; the **Right: 72 OK** message appears in the screen and the test program advances to the next test item automatically.

### 7. Switch1 & LED

Checks the function of switches with LED.  
When entering the Switch1 & LED test, the following message appears in the screen.

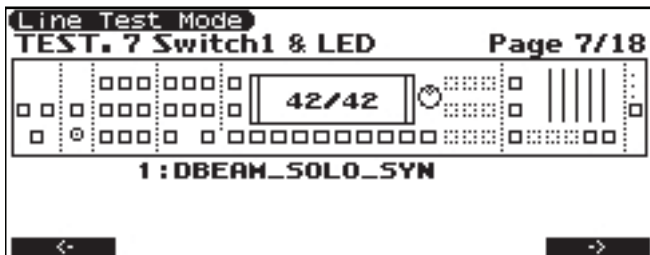

One of the switches with LED on the top panel lights. When pressing the switch, the next switch with LED lights. Continue this operation. When the tests of all switches are passed, the test program advances to the next test item automatically.

### 8. Switch2

Checks the function of switches without LED.  
When entering the Switch2 test, the following message appears in the screen.

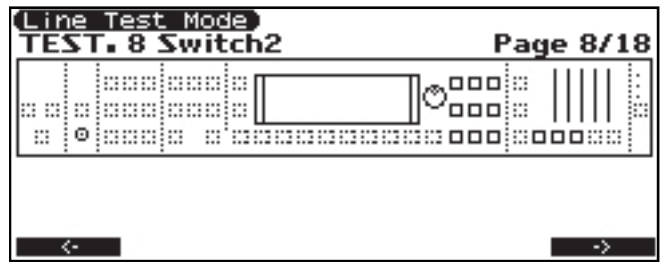

Press the switches drawn with solid lines one by one.  
Confirm the color of the corresponding switch will be light.  
When all switch's color are light and the test result is OK, the test program advances to the next test item automatically.

### 9. LCD

Checks the function of the LCD.  
When entering the LCD test, the following message appears in the screen.



Display pattern are changed whenever [F6] is pressed, then check whether dots are chipped, density is uniform, dust exist or not.

Tiles



Tiles (reversed)



All Over



Nothing



At last, press the [F6] button to advance to the next test item.

### 10. AD

Checks the functions of rotary volume or slide volume.  
When entering the AD test, the following message appears in the screen.

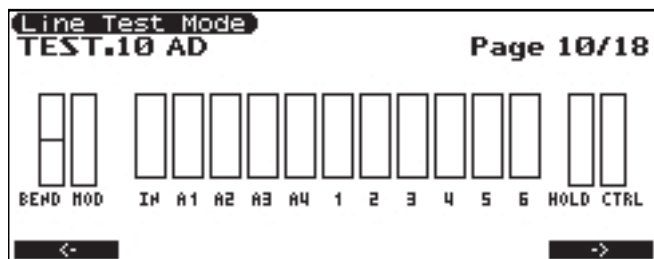

Except for the VOLUME knob and the AUDIO INPUT LEVEL knob on the rear panel, rotate or slide all knobs, sliders, the pitch bend lever and the expression pedals connected to the CONTROL jack and the HOLD jack one by one from MAX to MIN within available range.

\* Set the knob of EV-5 to 0.

Check the color of the corresponding bar changes light when each knob/slider is adjusted to MIN.

When all bars change light and test result is OK, the test program advances to the next test item automatically.

### 11. Mute

Checks the muting circuit.  
When entering the Mute test, the following message appears in the screen and the built-in demo song starts to play.

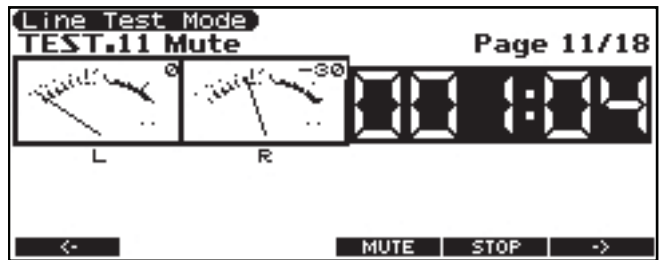

Rotate the VOLUME knob toward the MAX position slowly, confirm the sound is outputted from the PHONES jack.  
Next, confirm the sound is muted while the [F4] button is pressed.  
Press the [F6] button to advance to the next test item.

### 12. MIDI

Checks the MIDI signal flows correctly.  
When entering the MIDI test without connecting MIDI IN and MIDI OUT with a MIDI cable, the following message appears in the screen.



Connect MIDI IN and MIDI OUT with a MIDI cable. When the test is OK, the test program advances the next test item automatically.

### 13. Sound

Checks the audio input/output circuit.

#### Step 1/4 PHONES

Checks the audio signals (L and R) from the PHONES jack.  
When the following message appears in the screen, connect an oscilloscope to the PHONES jack.

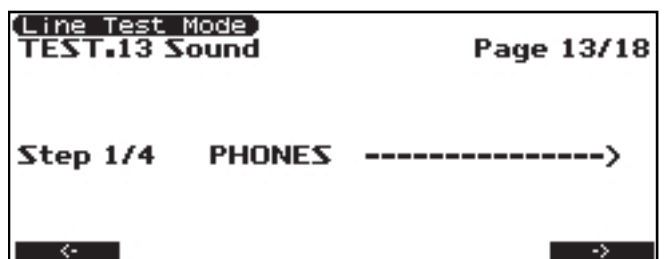

Adjust the VOLUME knob to MAX, and confirm the following audio signals are outputted correctly.

- L: 110 Hz sine wave
- R: 220 Hz sine wave

After confirming, press the [F6] button.

**Step 2/4 INPUT (LINE), OUTPUT A**

Checks the AUDIO INPUT, OUTPUT A and AUDIO INPUT LEVEL knob.  
The following message appears in the screen.

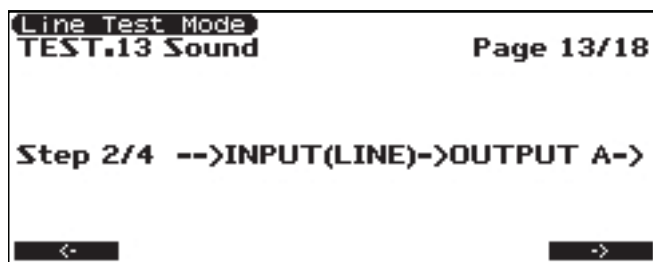

1. Connect an oscillator to the AUDIO INPUT L and R jacks, and connect an oscilloscope to the OUTPUT L and R jacks.
2. Adjust the VOLUME knob to MAX, and adjust the AUDIO INPUT LEVEL knob to MIN.
3. Input the following **Input Signal 1** to AUDIO INPUT L and R.  
**Input Signal 1:** Stereo Sine Wave, 1 kHz, 2 V pp
4. Check the output signals from OUTPUT A L and R change (increase or decrease) correctly correspond to the operation of the AUDIO INPUT LEVEL knob.
5. When the AUDIO INPUT LEVEL knob is adjusted to MAX, confirm the output signals of OUTPUT A L and R are as **Output Signal 1**.  
**Output Signal 1:** Stereo Sine Wave, 1 kHz, 6 V pp
6. Next, when inputting **Input Signal 2** to AUDIO INPUT L and R, confirm the output signals of OUTPUT A L and R change to **Output Signal 2**.  
**Input Signal 2:** Stereo Sine Wave, 20 kHz, 2 V pp  
**Output Signal 2:** Stereo Sine Wave, 20 kHz, 4.8 V pp
7. After confirming, press the [F6] button.

**Step 3/4 INPUT (LINE), OUTPUT B**

Checks the OUTPUT B.  
The following message appears in the screen.

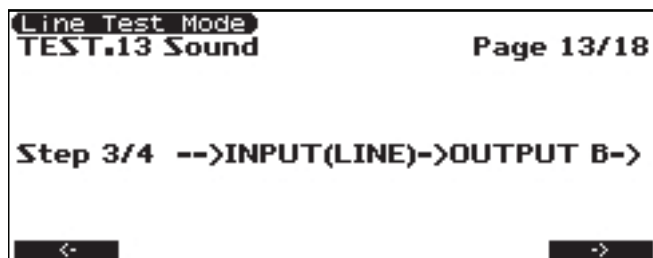

1. Remove the connections of the OUTPUT A L and R jacks, and connect the oscilloscope to the OUTPUT B L and R jacks.
2. Adjust both the VOLUME knob and the AUDIO INPUT LEVEL knob to MAX.
3. When inputting the following **Input Signal 1** to AUDIO INPUT L and R, confirm the output signals of OUTPUT B L and R are like **Output Signal 1**.  
**Input Signal 1:** Stereo Sine Wave, 1 kHz, 2 V pp  
**Output Signal 1:** Stereo Sine Wave, 1 kHz, 6 V pp
4. Next, when inputting **Input Signal 2** to AUDIO INPUT L and R, confirm the output signals of OUTPUT B L and R change to **Output Signal 2**.  
**Input Signal 2:** Stereo Sine Wave, 20 kHz, 2 V pp  
**Output Signal 2:** Stereo Sine Wave, 20 kHz, 4.8 V pp
5. After confirming, press the [F6] button.

**Step 4/4 INPUT (MIC), OUTPUT A**

Checks the MIC input.  
The following message appears in the screen.

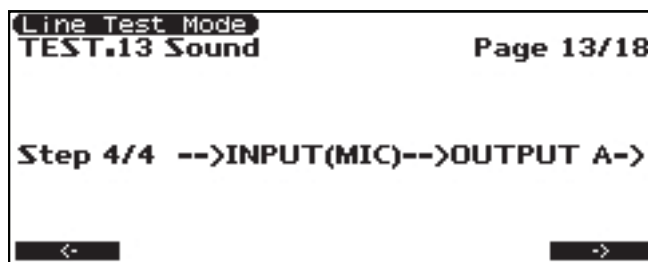

1. Remove the connection of the AUDIO INPUT R, and leave the connection of L (MONO)/MIC as it is.
2. Adjust both the VOLUME knob and the AUDIO INPUT LEVEL knob to MAX.
3. When inputting the following **Input Signal 1** to AUDIO INPUT L (MONO)/MIC, confirm the output signal of OUTPUT A L (MONO) is like **Output Signal 1**.  
**Input Signal 1:** Mono Sine Wave, 1 kHz, 0.16 V pp  
**Output Signal 1:** Mono Sine Wave, 1 kHz, 6 V pp
4. After confirming, press the [F6] button.

**14. USB**

Checks the function of USB.  
When entering the USB test, the following message appears in the screen.



Connect the JUNO-G and PC (equipped with a USB connector, OS: Windows Me/2000/XP) with a USB cable.

When they are connected correctly, the message **Status: Connect** appears.

Cancel the connection with the JUNO-G by device eject button shown in the taskbar at the lower right of the PC screen.

If the test is OK, the test program advances to the next test item automatically.

## 15. D Beam

Checks the D BEAM controller.

When entering the D BEAM test, the following message appears in the screen.

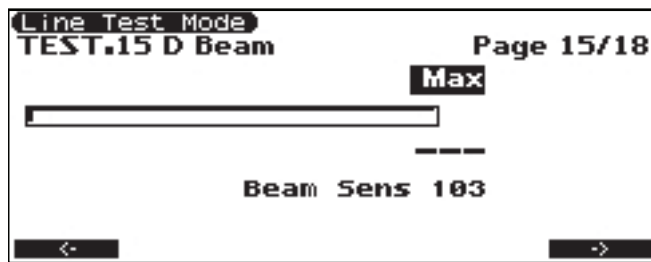

Adjust the **Sens** value with the VALUE dial or [INC]/[DEC] buttons to meet with the following three conditions.

- Value is **0** or **---** when not holding a hand over the D Beam Controller.
- Value is **1-30** when moving a hand up and down over the D Beam Controller and hold it at position about 35 cm over the panel.
- Value is **127** when holding a hand at about 5 cm over the panel.

When the value **0** and **127** are detected, the test program advances to the next test item automatically.

## 16. Keyboard

Checks the Keyboard.

When entering the Keyboard test, the following message appears in the screen.

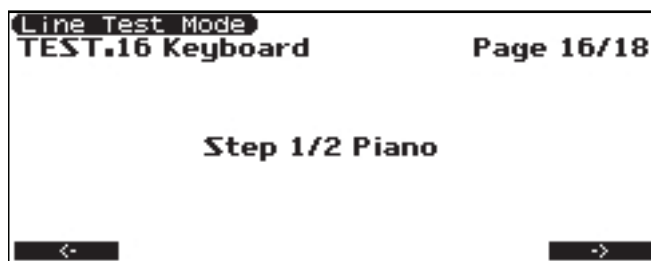

Hit all keys and check they sound with piano sound.

And also, check the volume changes correspond to the force of hitting keys.

Press the [F6] button to change the tone to the organ sound, and play the keyboard to confirm all keys sound correctly.

Press the [F6] button to advance to the next test item.



Press at least one key, or the test program will not advance to the next test item.

## 17. Noise

Checks the residual noise with a noise meter.

The following message appears in the screen.

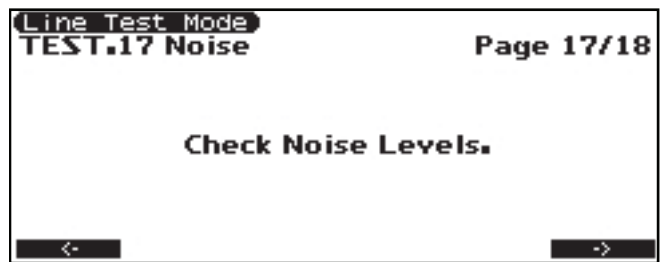

Rotate the VOLUME knob to MAX.

Set the input filter of the noise meter to **DIN Audio**, and confirm to meet with the following requirements.

<b>OUTPUT A</b>	<b>L:</b>	-80 dB or less
	<b>R:</b>	-80 dB or less
<b>OUTPUT B</b>	<b>L:</b>	-80 dB or less
	<b>R:</b>	-80 dB or less

If there is no problem, press [F6] to advance to the next test item.

## 18. Factory Reset

Executes the Factory Reset.

The following message appears in the screen.



Press [ENTER] to execute the Factory Reset.

When completing the Factory Reset, the following message appears in the screen and the Test Mode are finished.



Turn off the power of the JUNO-G, and remove the DIMM and the Expansion Board.

# Block Diagram

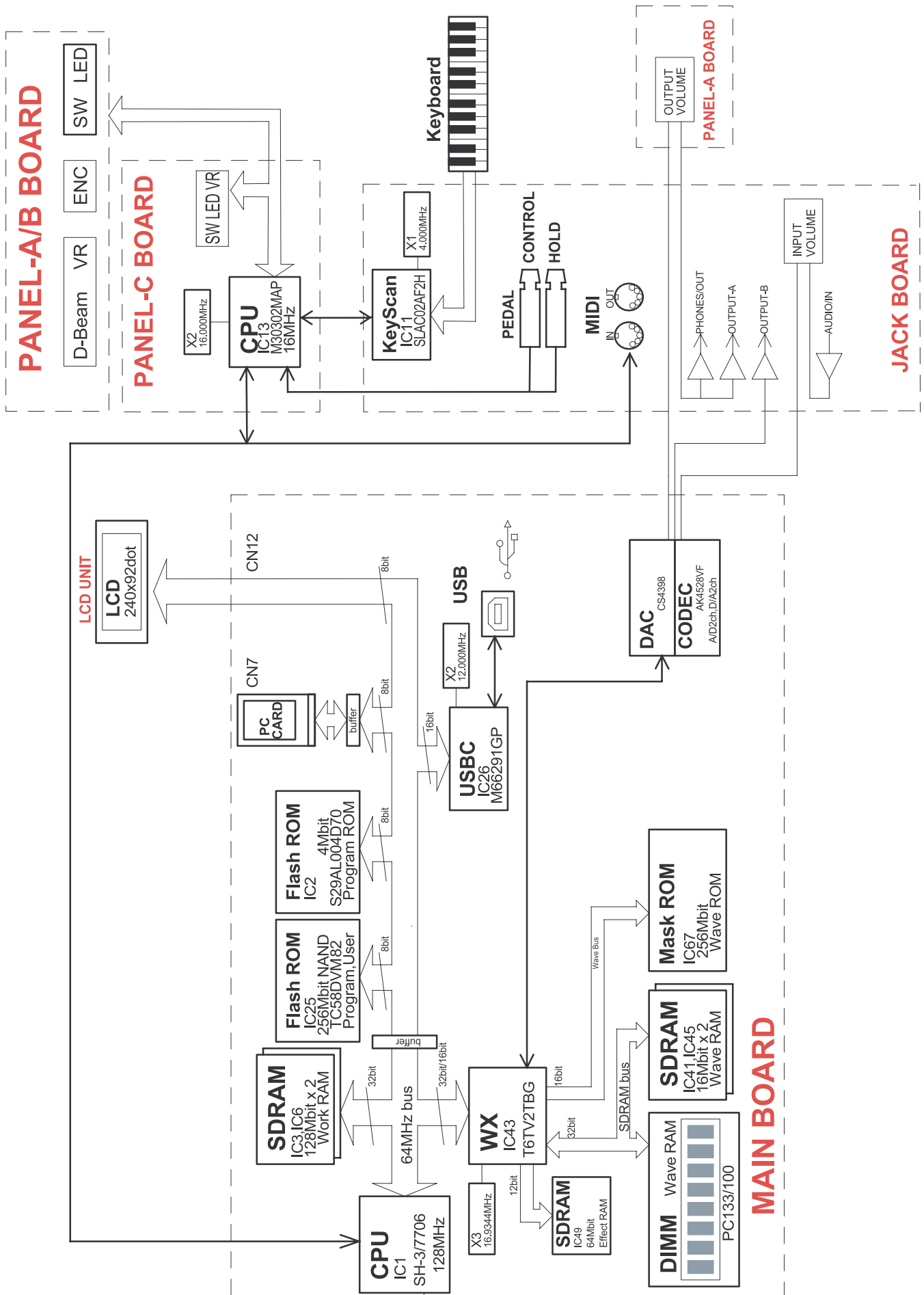

# Circuit Board (MAIN Board: 1/2)

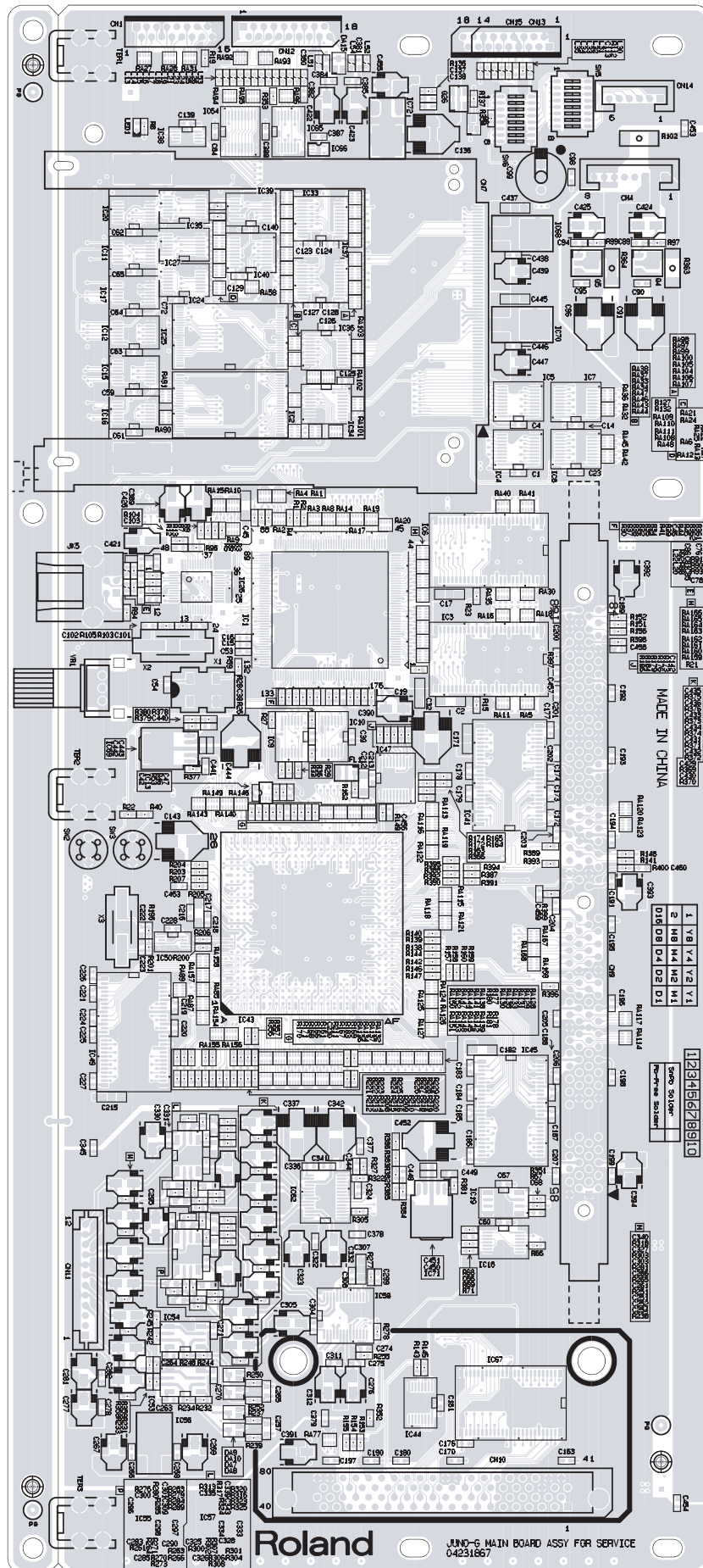

Circuit Board (MAIN Board: 2/2)

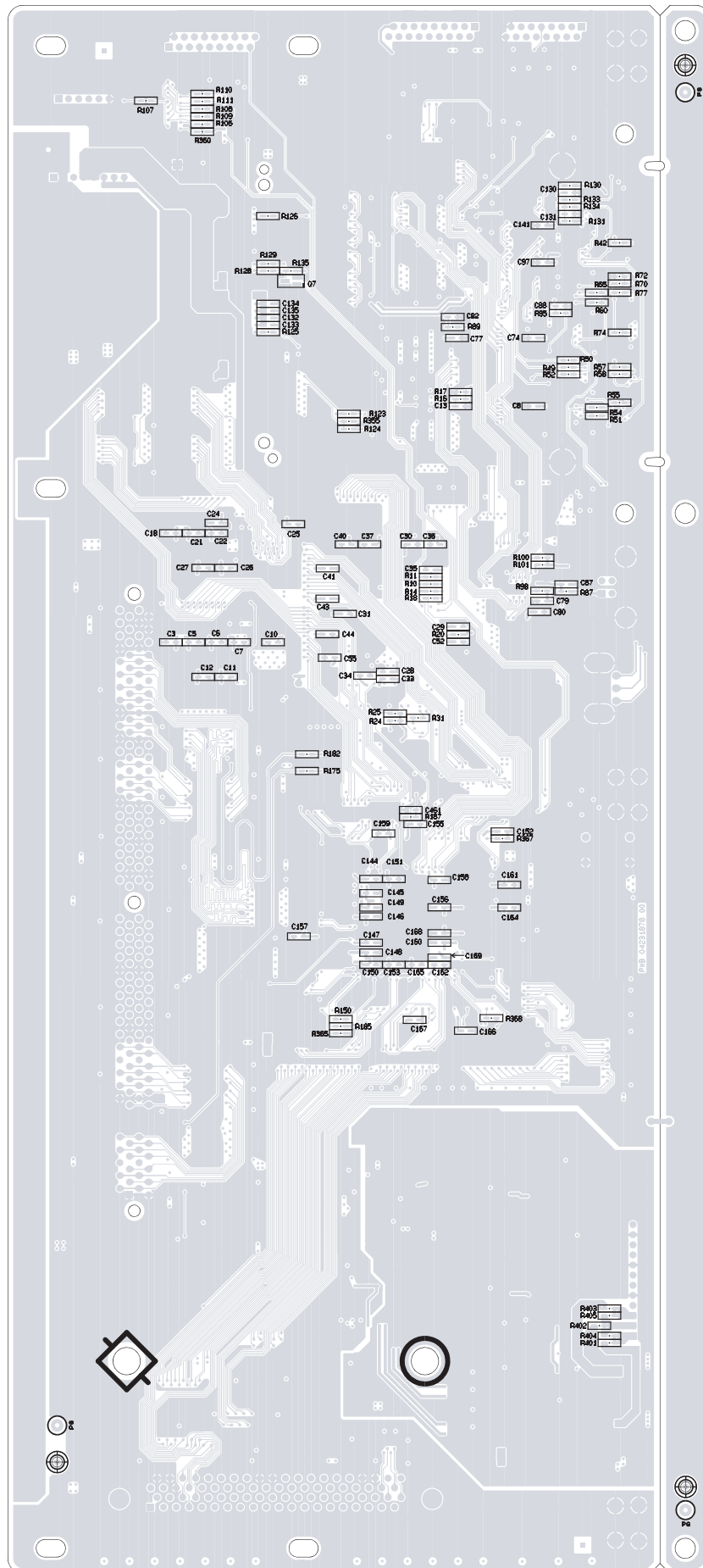



# Circuit Board (JACK, PANEL-C, LCD Board: 1/2)

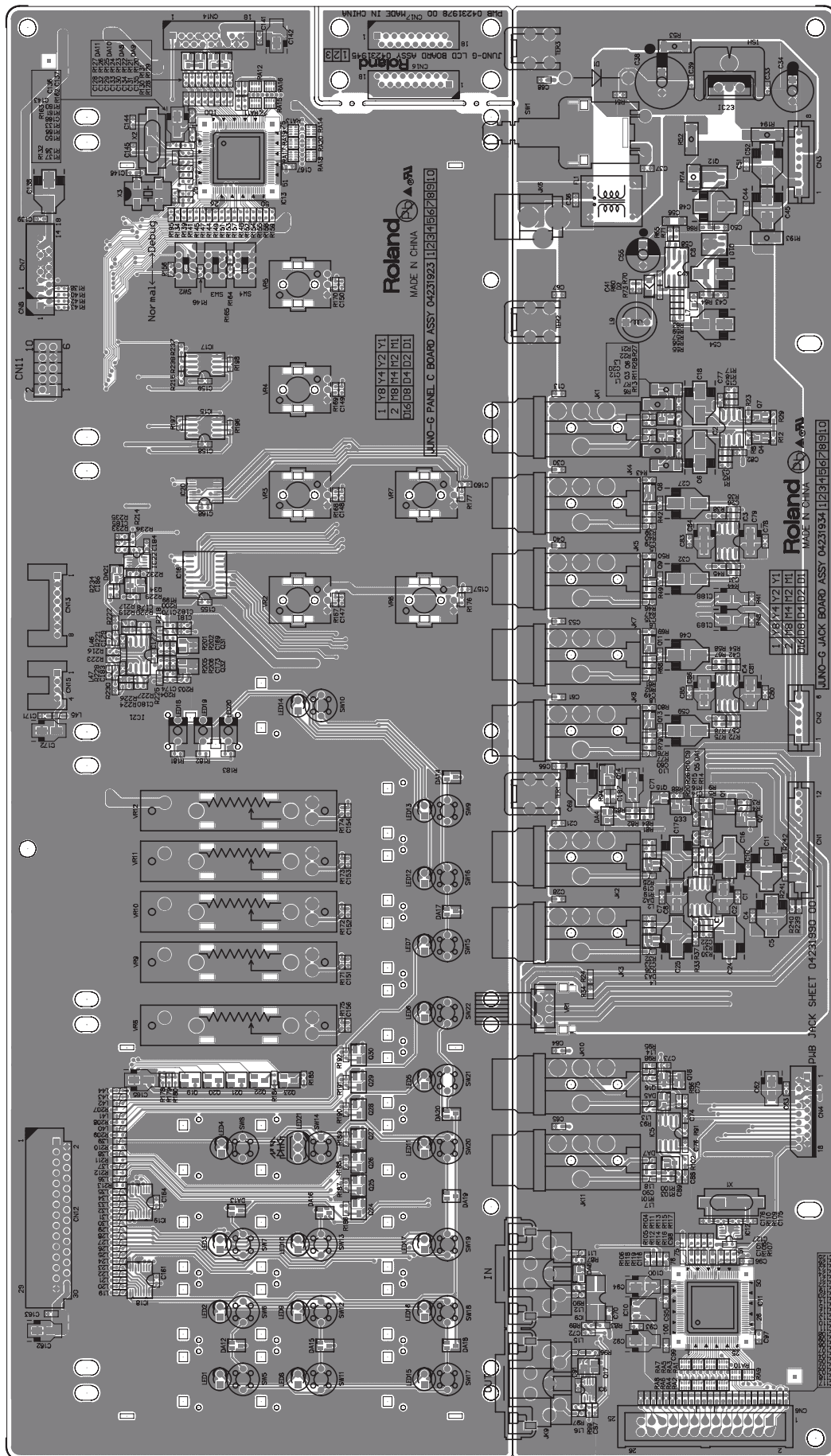

**Circuit Board (JACK, PANEL-C, LCD Board: 2/2)**

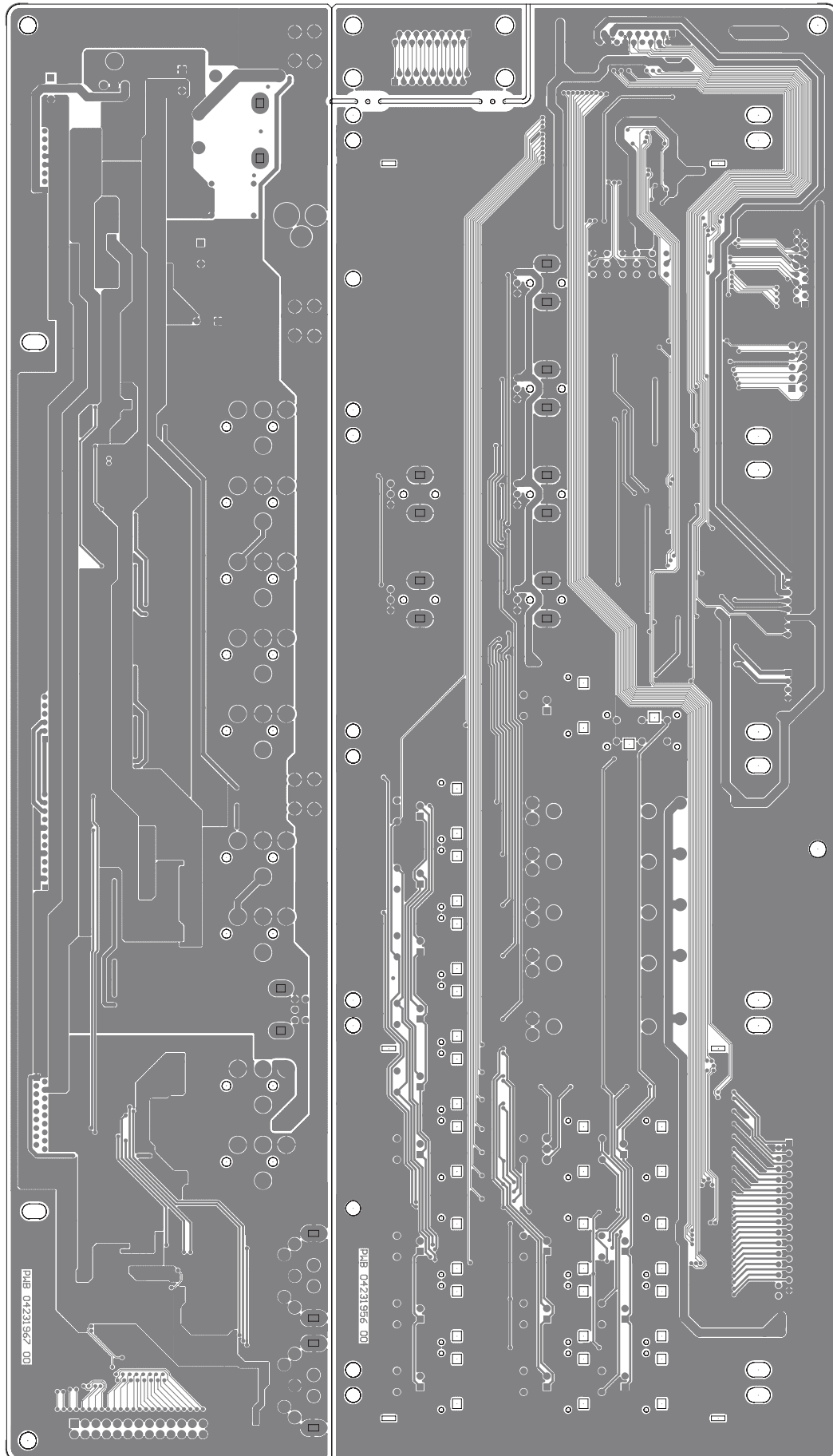

# Circuit Board (PANEL-A, B Board)

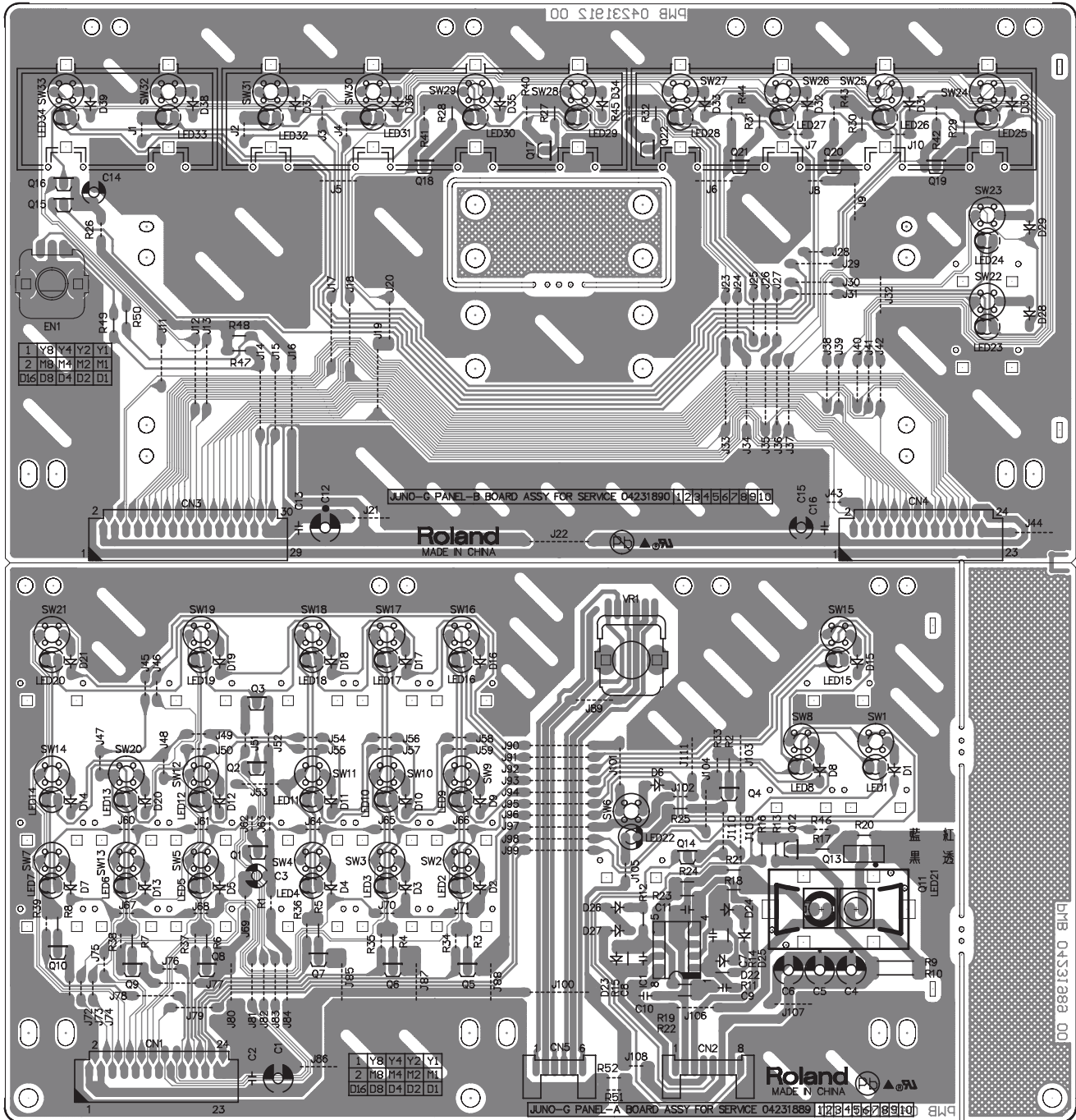



# Circuit Diagram (MAIN Board: 1/4)

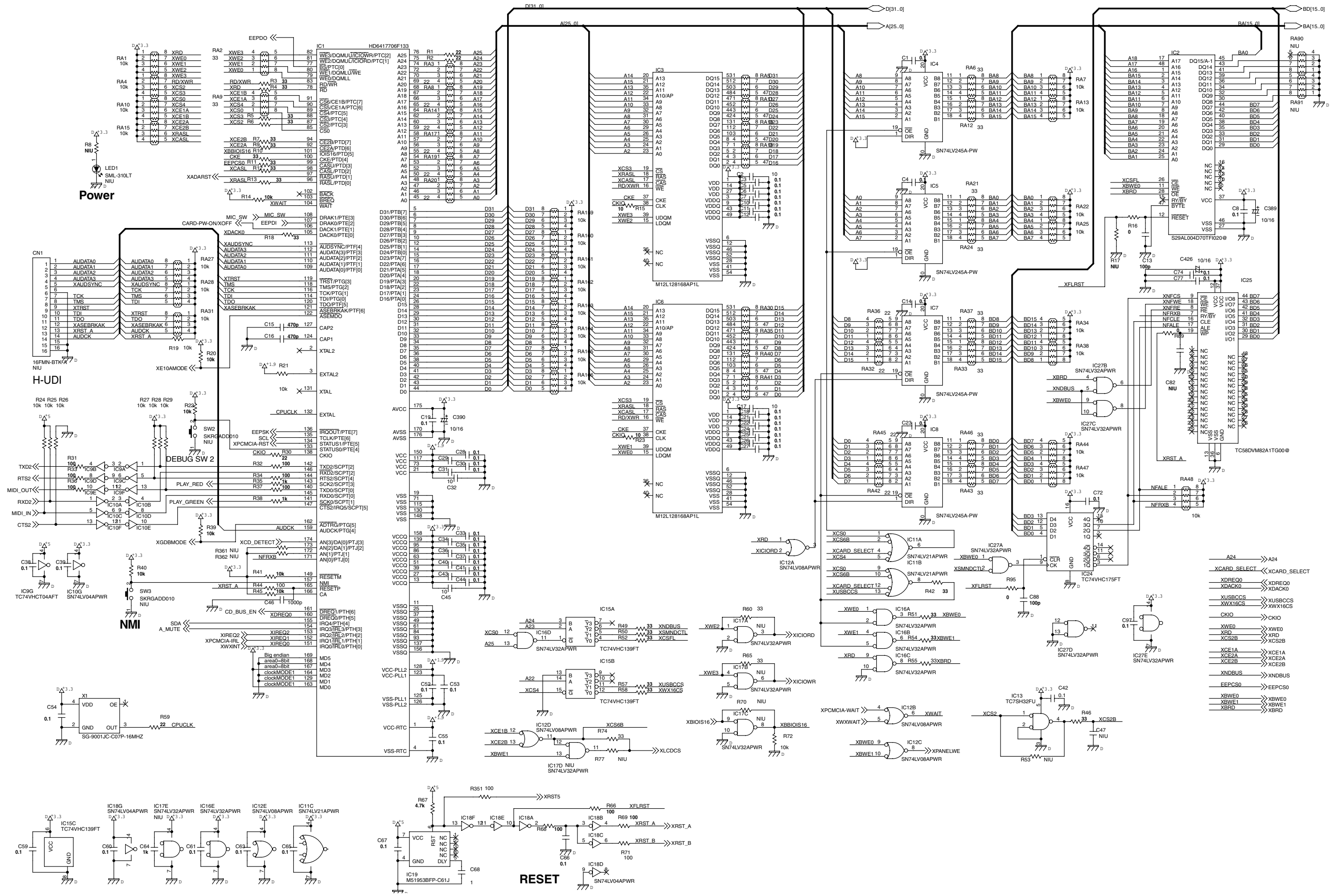

# Circuit Diagram (MAIN Board: 2/4)

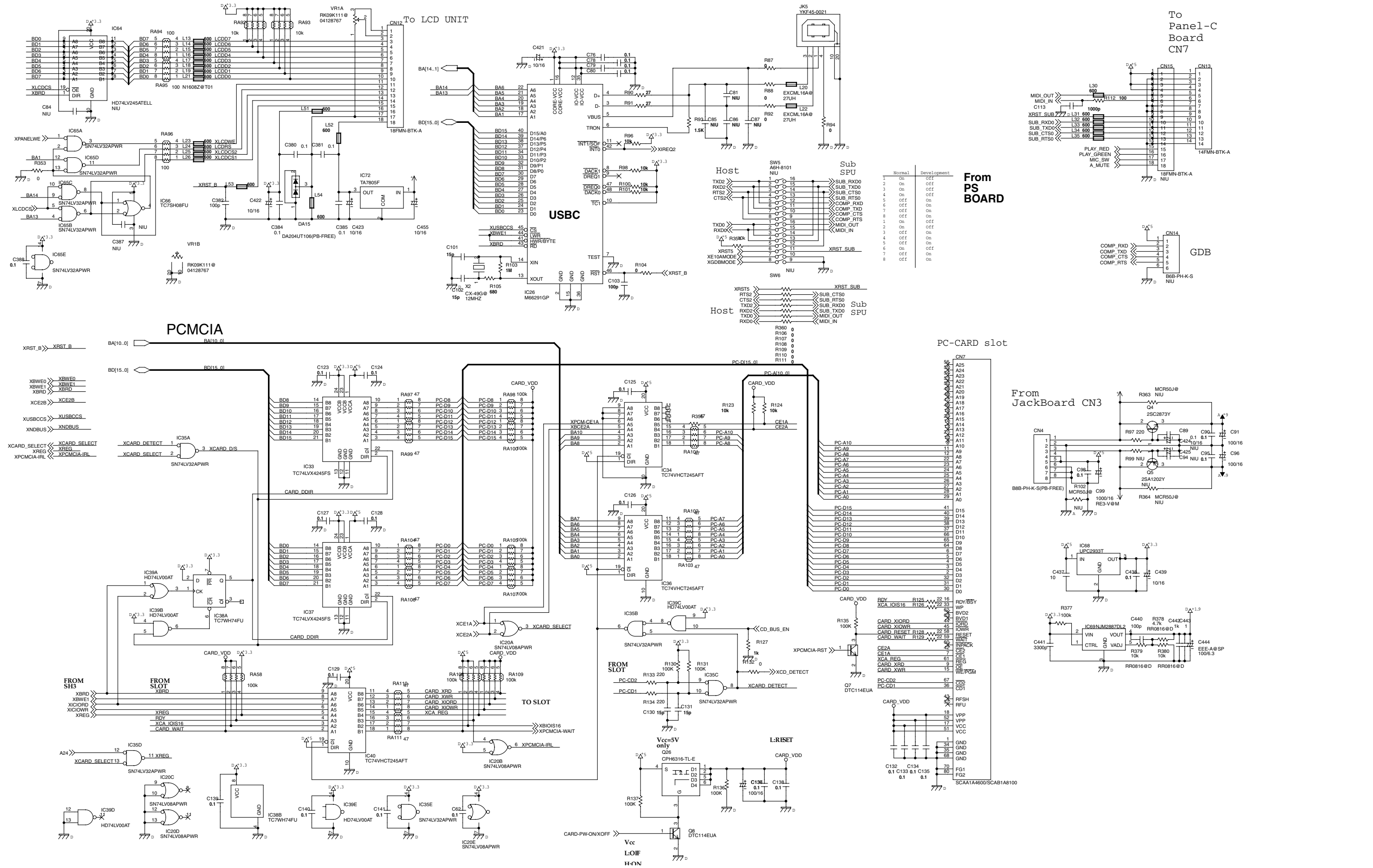

# Circuit Diagram (MAIN Board: 3/4)

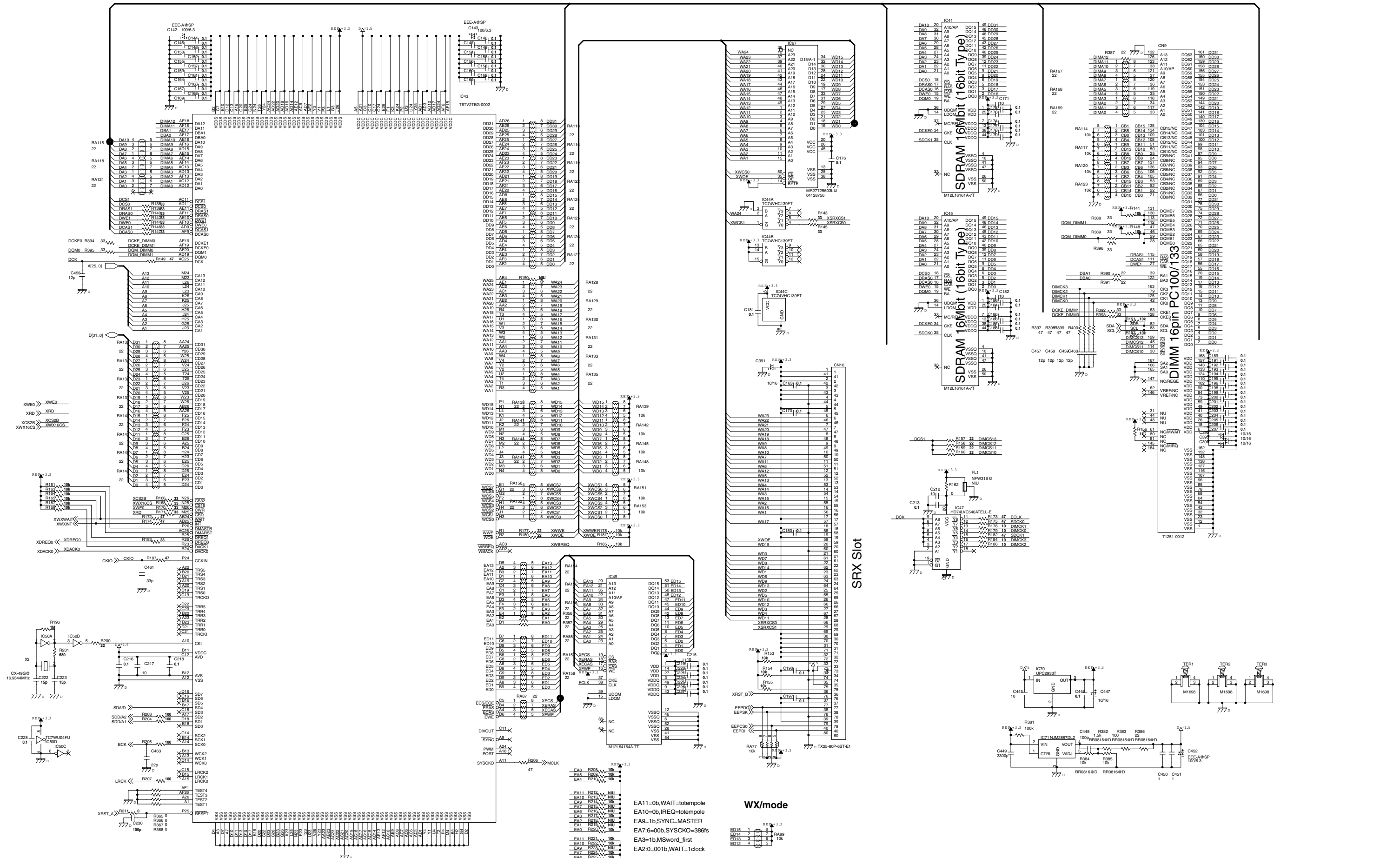

# Circuit Diagram (MAIN Board: 4/4)

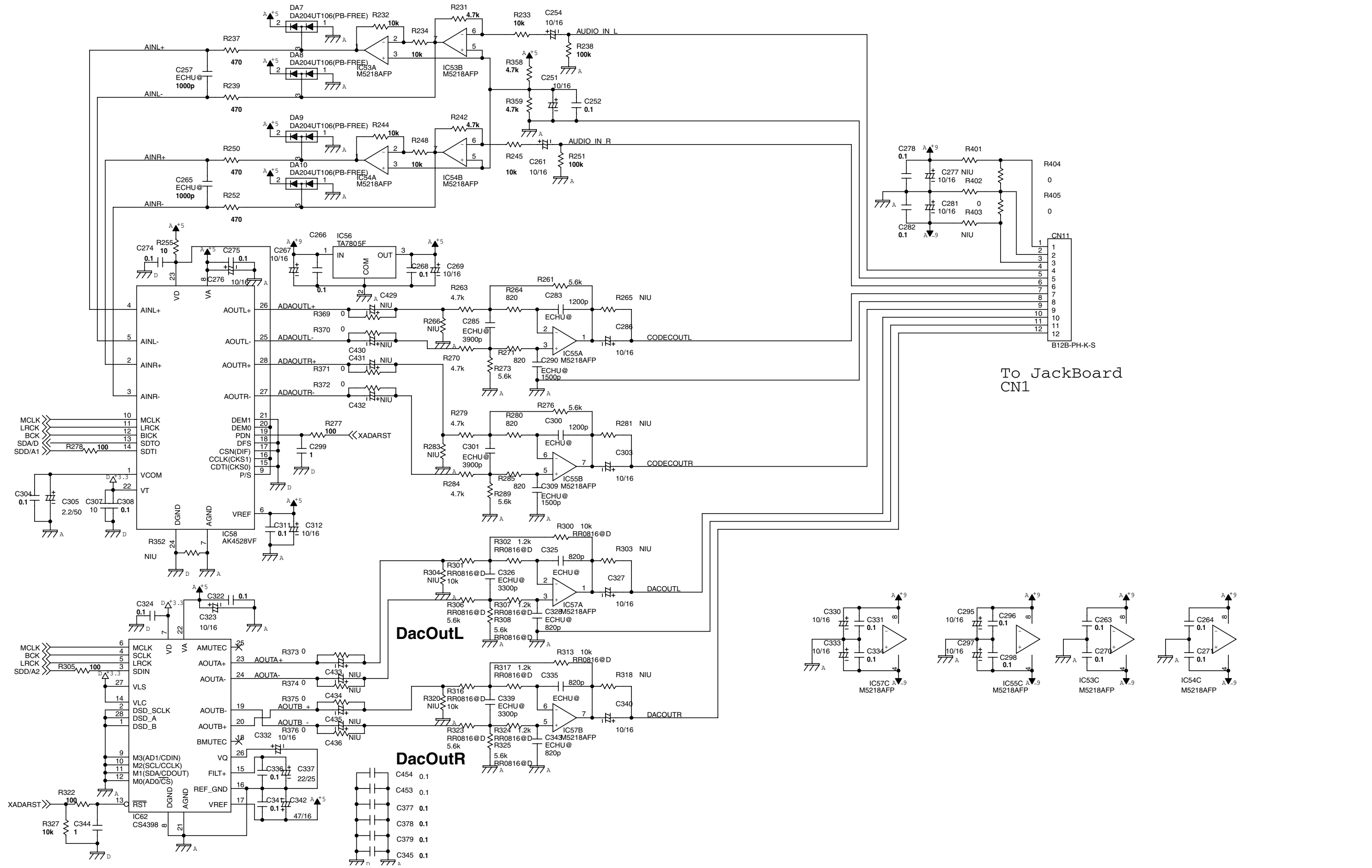

To JackBoard  
CN1



# Circuit Diagram (JACK Board: 1/2)

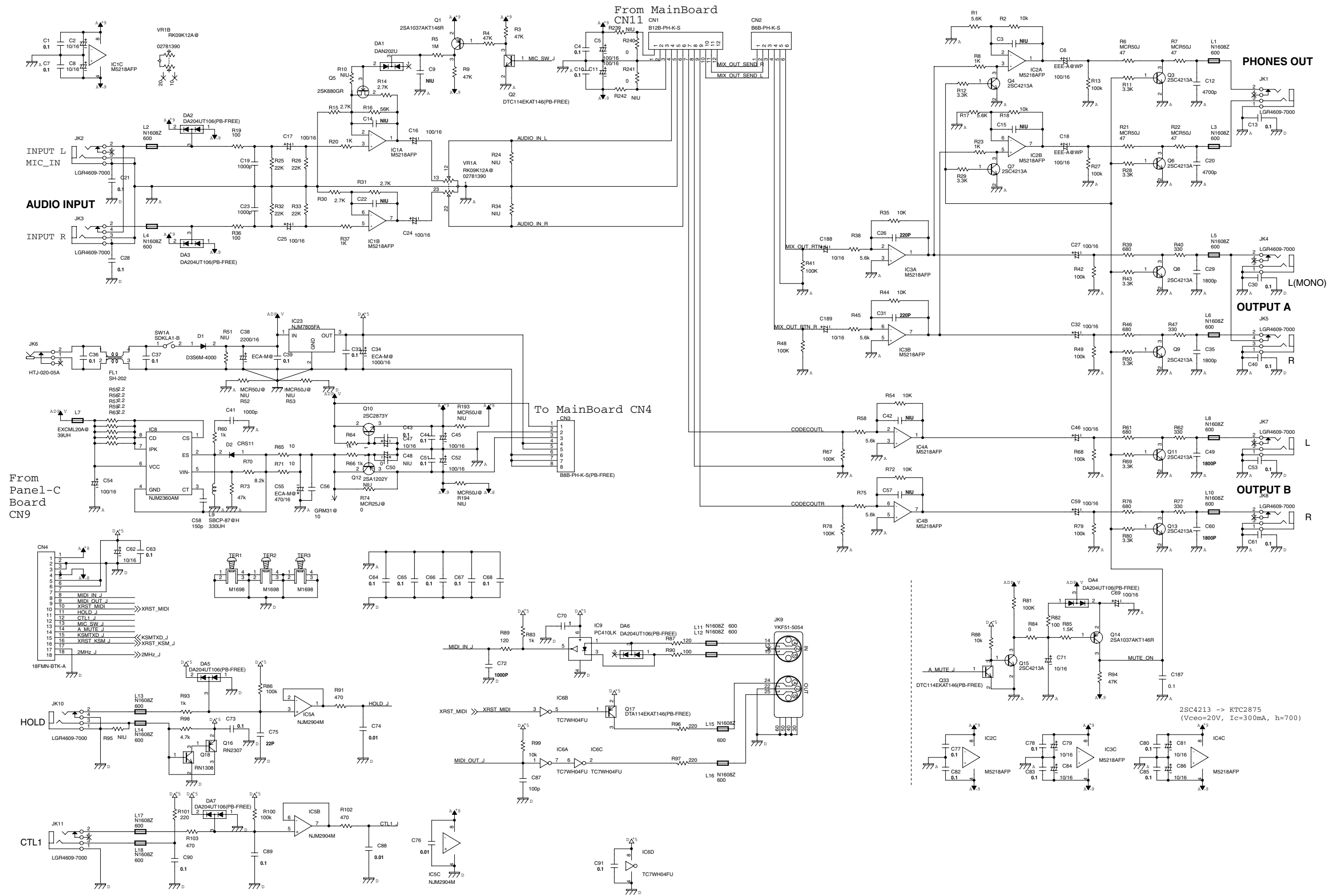

All parts on Jack Board PWB

# Circuit Diagram (JACK Board: 2/2)

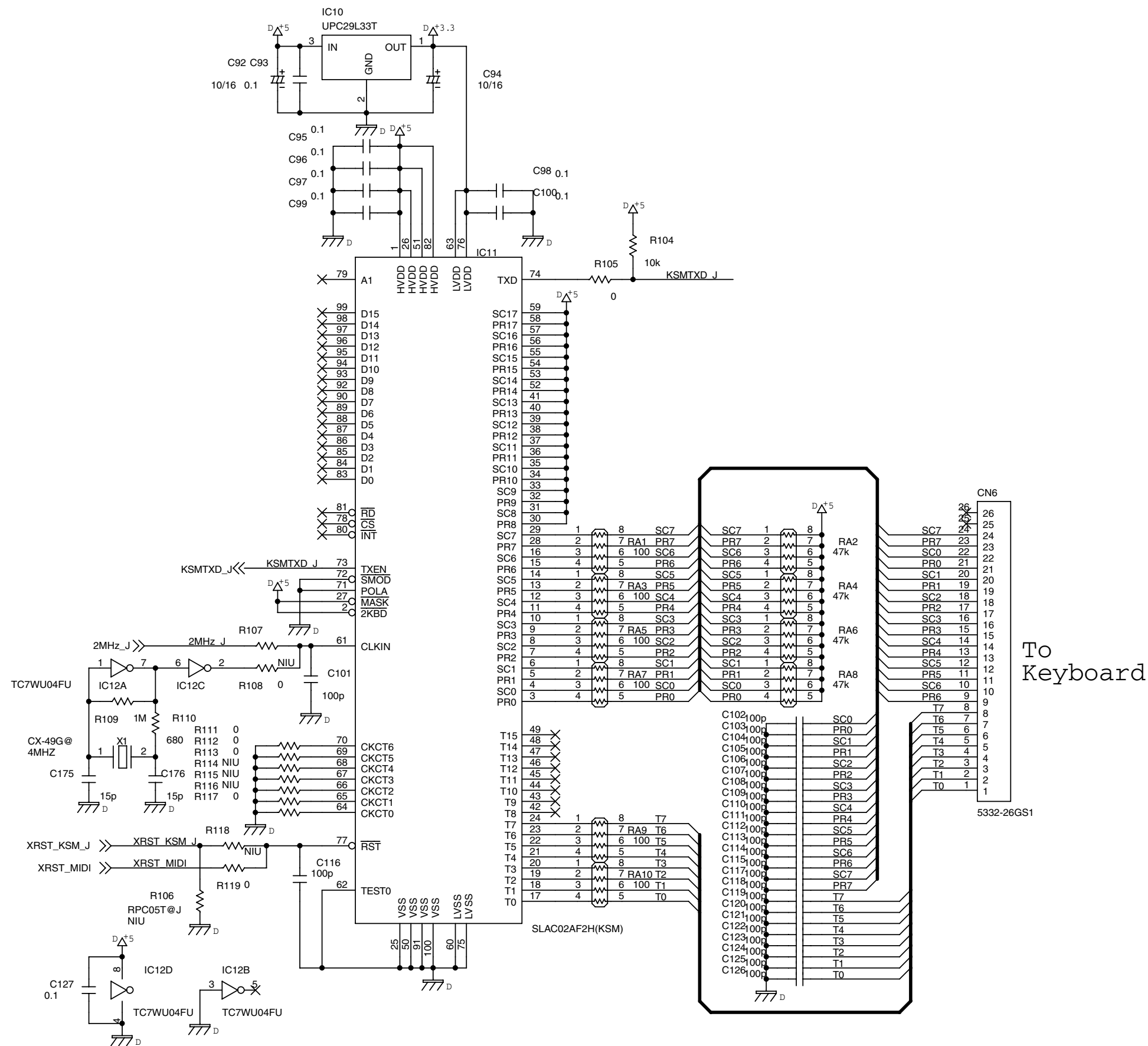

All parts on Jack Board PWB

# Circuit Diagram (PANEL-A Board)

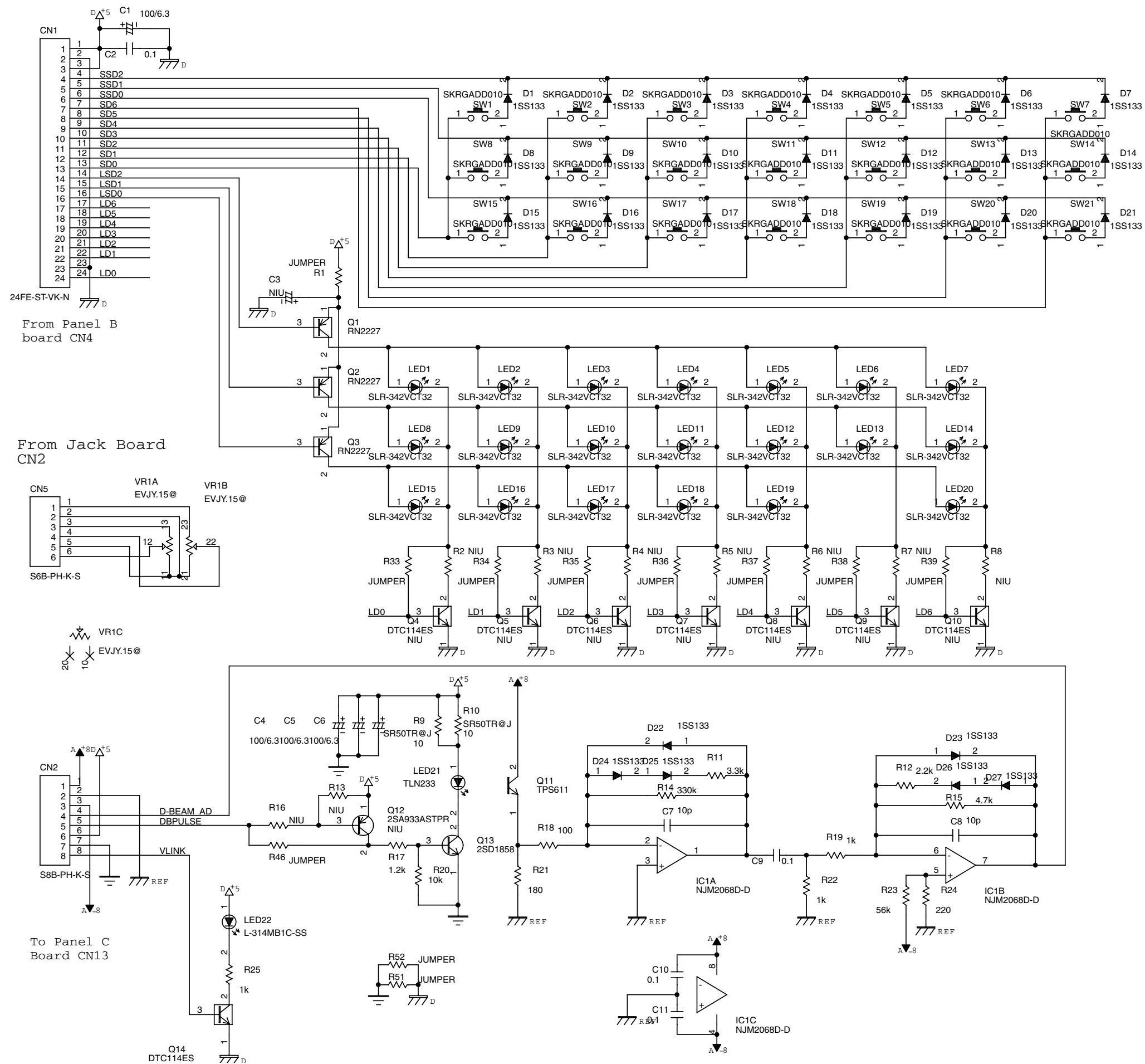

# Circuit Diagram (PANEL-B Board)

From Panel C Board CN12

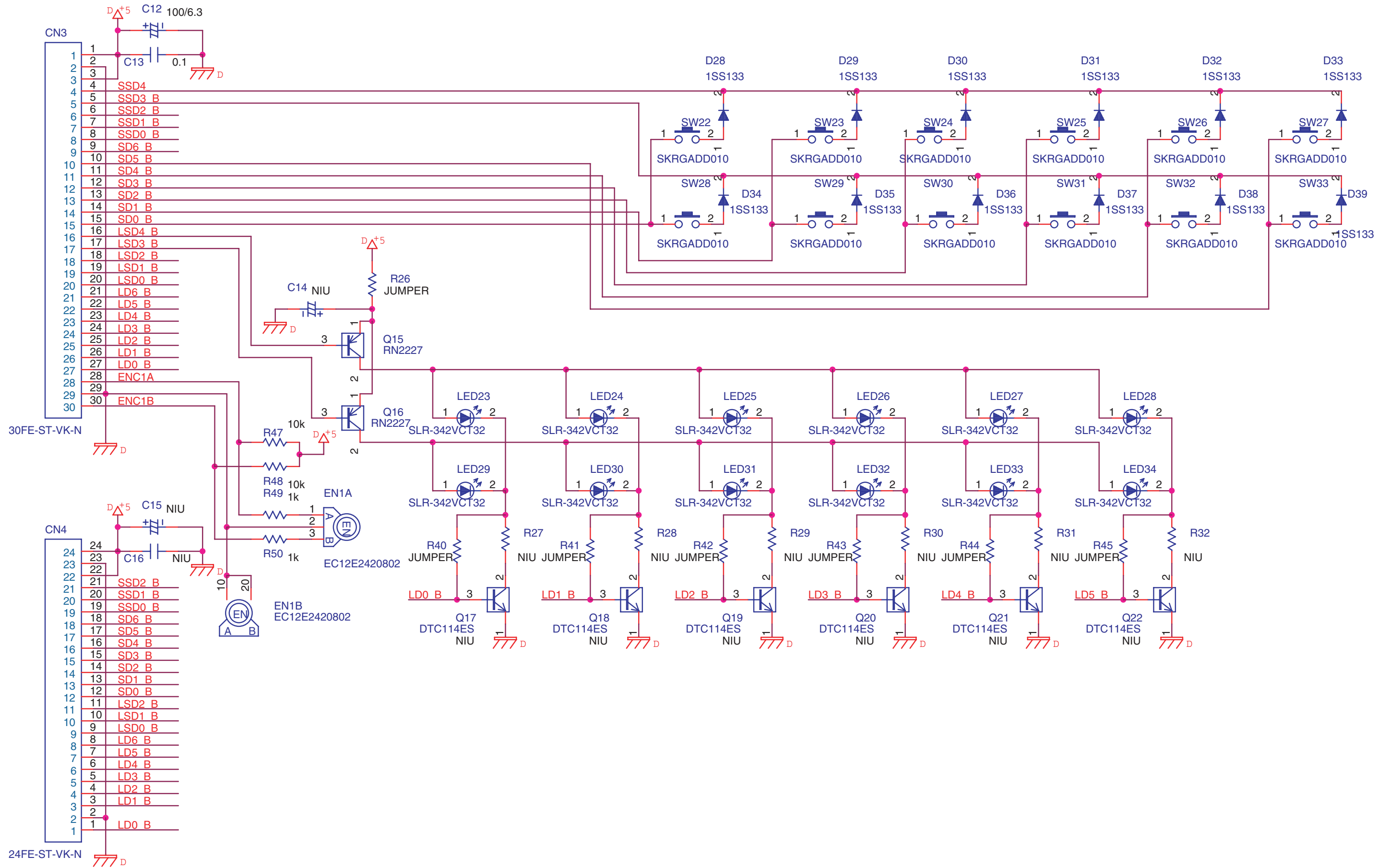

TO Panel A Board CN1

# Circuit Diagram (PANEL-C Board: 1/2)

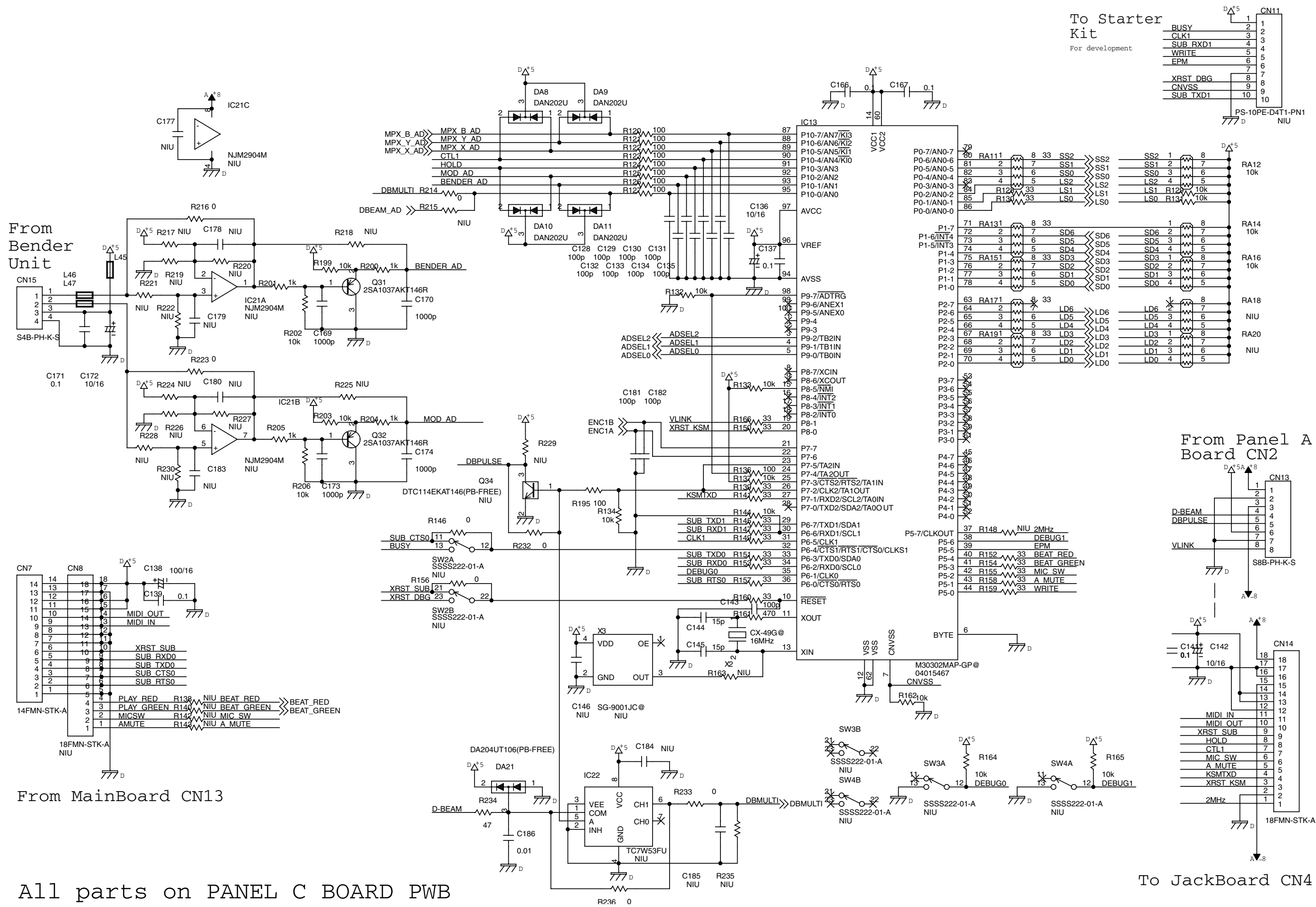

All parts on PANEL C BOARD PWB

# Circuit Diagram (PANEL-C Board: 2/2)

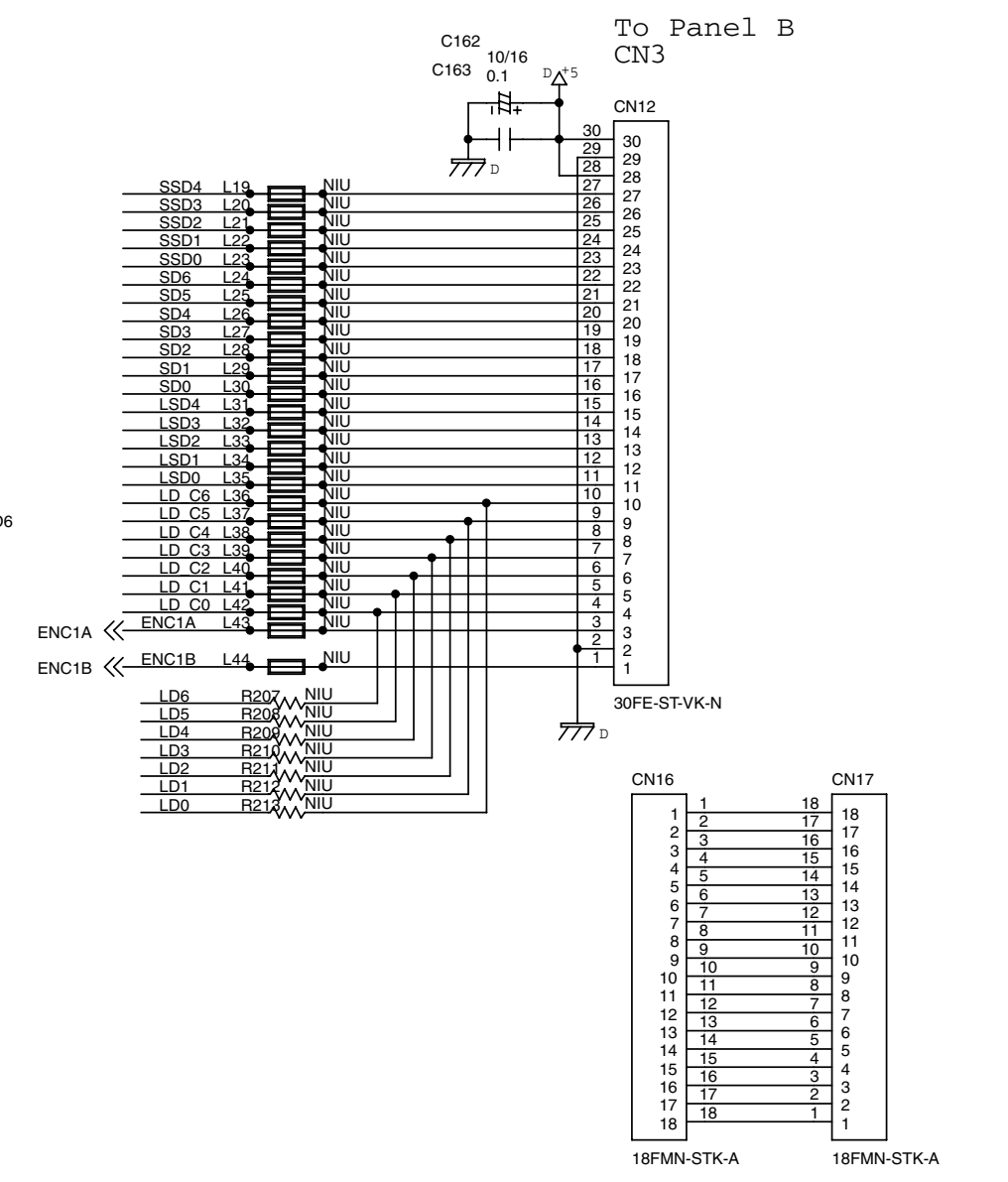
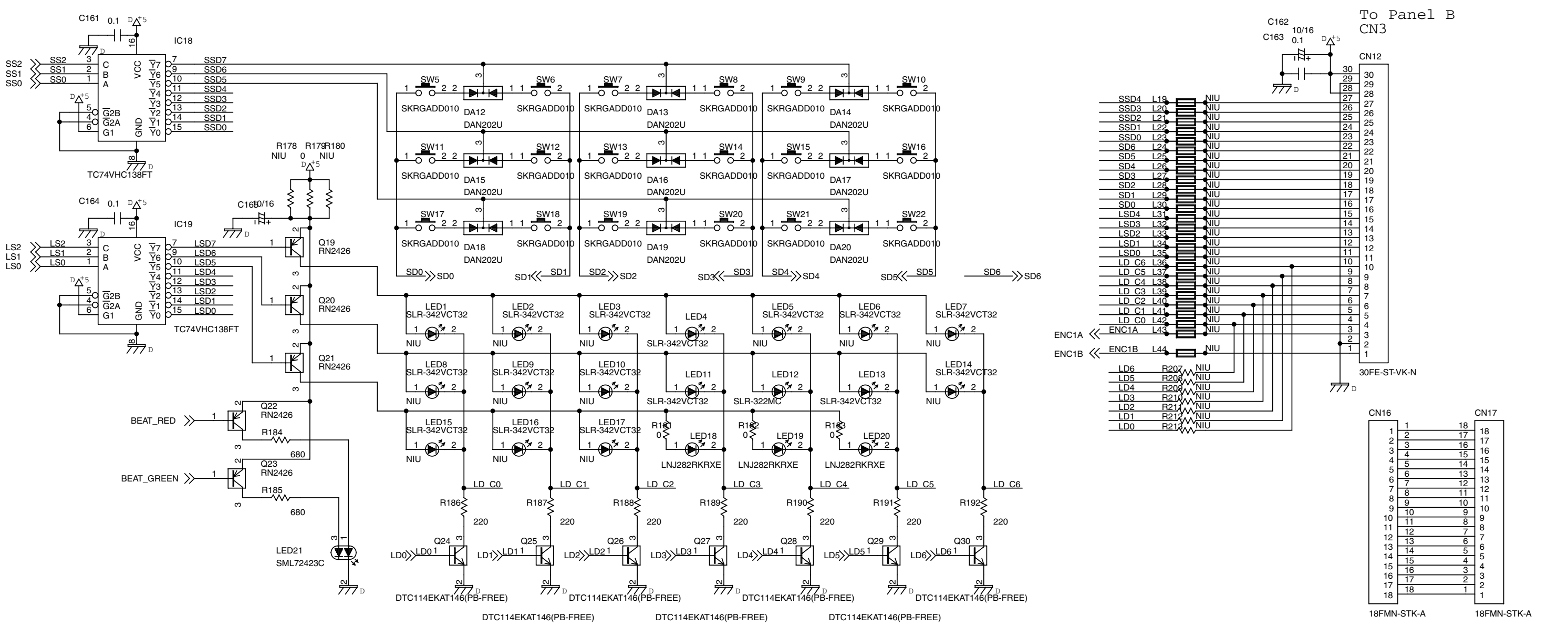
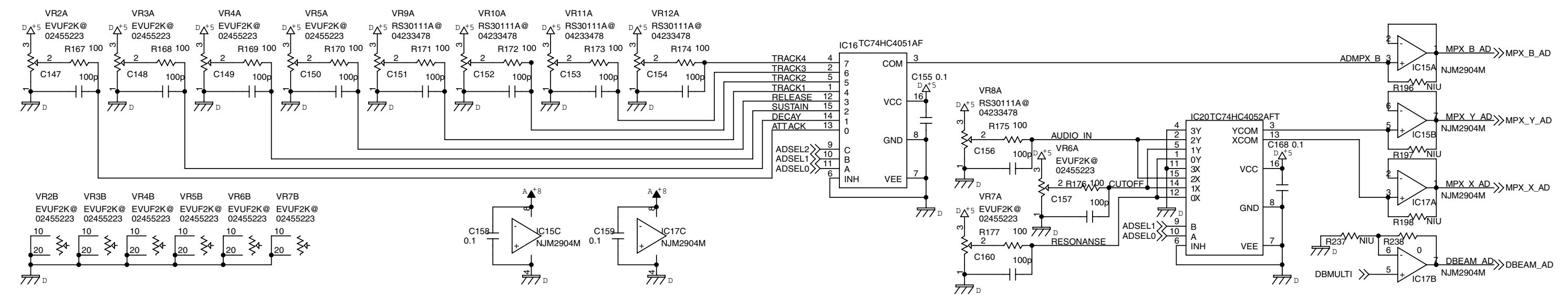

All parts on PANEL C BOARD PWB

## Error Messages

If an incorrect operation is performed, or if processing could not be performed as you specified, an error message will appear. Refer to the explanation for the error message that appears, and take the appropriate action.

Message	Meaning	Action
Cannot Edit Preset Sample!	This is a preset sample, and therefore cannot be edited.	-
Card Not Ready!	A memory card is not inserted in the slot.	Insert a memory card into the slot.
Data not found	The data for placement is not specified.	-
Empty Sample!	The sample contains no data.	Select a sample that contains data.
Empty Song!	The song has not been recorded, and therefore cannot be played.	Select a song that contains data.
File Name Duplicate	A file with the same name already exists.	Delete the file bearing the same name from the disk, and if overwriting and saving the data, merely save the file. If you do not want to delete the file with the same name from the disk, either save the file with a different name.
Illegal File!	The JUNO-G cannot use this file.	-
Memory Damaged!	The contents of memory may have been damaged.	Please perform the Factory Reset operation. If this does not resolve the problem, please contact your dealer or the nearest Roland Service Center.
Memory Full!	Saving is not possible because there is insufficient space in the user area or memory card.	Delete unneeded data.
MIDI Offline!	There is a problem with the MIDI cable connection.	Check that the MIDI cable has not been disconnected or broken.
Movable onto Bar Line Only	The beat change event can be put only on bar line (beginning of a measure).	-
No More Note Numbers!	A maximum of 16 different note numbers can be used in one style of the arpeggio/rhythm function.	Please delete unneeded notes.
No More Sample Numbers!	The sample cannot be divided any further. Since fewer than 256 consecutive sample numbers are vacant, no further sampling is possible.	Erase unneeded samples in order to allocate 256 or more consecutive sample numbers.
No More Song Numbers!	No more songs can be saved. A maximum of 256 songs can be handled simultaneously for both the user bank and card bank.	Please delete unneeded songs.
Now Playing!	Since the JUNO-G is playing, this operation cannot be executed.	Stop playback before you execute the operation.
Permission Denied!	The file is protected.	-
Playback Tempo Range Over	Tempo values exceed the allowable limit, and data is created in which the closest time available within the allowable range is specified.	-
Power off and check DIMM	Turn off the power immediately, and re-insert the DIMM memory correctly.	-
Recording Parameter Error	You are attempting to begin recording after a looped segment.	You are attempting to begin recording within or before a looped segment.
Rec Over Flow	Since a large amount of recorded data was input all at once, it could not be processed correctly.	Reduce the amount of recorded data.
Sample Length Too Short!	The sample is too short, and cannot be edited correctly.	If the sample is extremely short, editing may not produce the desired result.
Sample Memory Full!	Since there is insufficient sample memory, no further sampling or sample editing is possible.	Erase unneeded samples.
Song Format Error	This song is damaged.	This song cannot be used.
Song Full	Since the maximum number of notes that can be recorded in a song has been exceeded, no further recording/editing is possible.	Use the track edit Delete or Erase commands to remove unneeded data from the song that you are recording/editing.
Song Not Found	The selected song cannot be found.	-
Too Many Sample Selected!	The operation cannot be executed, since marks are assigned to more than one sample.	Either clear the marks, or mark only one sample.
Unformatted!	The memory card is in an unsupported format.	Format the memory card.
You Cannot Copy This Message	This message cannot be copied.	-
You Cannot Erase This Message	This message cannot be erased.	-
You Cannot Move This Message	This message cannot be moved.	-





---

# MEMO