

# 첨부 1 : BOM



# 부속 구성 명세표

품번: D05PS4015 PDP PS-424-PH(101C)  
 등록번호: 20050902  
 개발자: 이진영  
 등록자: 김아롱

구분 Draw No. REV  
 DRAW 220-05-008D 0 BOM 220-05-008B B  
 SPEC 220-05-008S A  
 M.ASSY DRAW 220-05-008M 0

page: 2 / 31

순번	자품목번호	품명	UOM	공정명	대체품 코드	대체품 품명	자재위치
Level	조달구분	규격	단위	제조사	대체품 규격	대체품 제조사	부품 PACKING 단위
1	D05PS40156	PDP	1.00000	E/T			
1	제작	PS-424-PH(101C)	EA				1
1	D05PS401568	PDP	1.00000	E/T			
2	제작	PS-424-PH(101C)	EA				1
1	D05PS4015682	PDP	1.00000	ASY-3			
3	제작	PS-424-PH(101C)	EA				1
1	D05PS40156824	PDP	1.00000	ASY-1			
4	제작	PS-424-PH(101C)	EA				1
1	D05PS40156828	PDP	1.00000	ASY-2			
5	제작	PS-424-PH(101C)	EA				1
1	E431030013-L	CAP/FILM	1.00000				C8117
6	구매	103K/250V/85℃ MT(5mm)	EA	명성콘덴서(주)			1
2	E431040031-L	CAP/FILM	1.00000				C8104
6	구매	104K/400V/85℃ MT(7.5mm)	EA	명성콘덴서(주)			1
3	E431050024-L	CAP.FILM	2.00000				C8202,203
6	구매	105K/100V/85℃ MT(7.5mm)	EA	명성콘덴서(주)			1
4	E434730008-L	CAP.FILM	2.00000				C8051,85
6	구매	473K/400V/85℃ MT(5mm)	EA	명성콘덴서(주)			1
5	E431030014-L	CAP/FILM	1.00000				C8109
6	구매	103K/400V/85℃ MT(5mm)	EA	명성콘덴서(주)			1
6	E421010007-L	C-CAPACITOR	1.00000				C8041
6	구매	EK B 3A 101K 06 FK5(101K/1KV)	EA	삼화콘덴서			1
7	E421020027-L	CAPACITOR	1.00000				C8043
6	구매	EK B 3A 102K 08 FK5(102K/1KV)	EA	삼화콘덴서			1
8	E421030013-L	CAP.CERAMIC	2.00000				C8040,243
6	구매	EK F 3A 103Z 10 FK5(103Z/1KV)	EA	삼화콘덴서			1
9	E422210014-L	C-CAPACITOR	1.00000				C8239
6	구매	EK B 3A 221K 06 FK5(221K/1KV)	EA	삼화콘덴서			1
10	E424710012-L	CAPACITOR	1.00000				C8018
6	구매	EK B 3A 471K 06 FK5(471K/1KV)	EA	삼화콘덴서			1

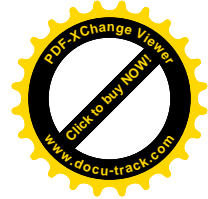
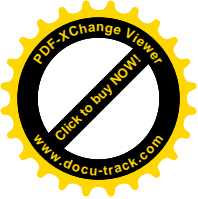

순번	자품목번호	품명	UOM	공정명	대체품 코드	대체품 품명	자재위치
Level	조달구분	규격	단위	제조사	대체품 규격	대체품 제조사	부품 PACKING 단위
11	E471010072-L	CAP,ELEC	1.00000				C8062
6	구매	GF 100uF/25V/105°C(6.3*11)	EA	MANYUE			1
12	E471010039-L	CAP/AL	2.00000				C8019,111
6	구매	GF 100uF/35V/105°C(8*12)	EA	MANYUE			1
13	E471010073-L	CAP,ELEC	2.00000				C8069,149
6	구매	GF 100uF/50V/105°C(10*12.5)	EA	MANYUE			1
14	E471000059-L	CAP/AL	4.00000				C8029,71,96,124
6	구매	GF 10uF/50V/105°C(5*11)	EA	MANYUE			1
15	E474R70029-L	CAP/AL	1.00000				C8035
6	구매	GF 4.7uF/50V/105°C(5*11)	EA	MANYUE			1
16	E474700064-L	CAP,ELEC	3.00000				C8006,34,113
6	구매	GF 47uF/35V/105°C(6.3*11)	EA	MANYUE			1
17	E471020069-L	ELETROLYTIC CAP.	2.00000				C8045,48
6	구매	KM 1000uF/10V/105°C(10*12.5)	EA	MANYUE			1
18	E471020067-L	ELETROLYTIC CAP.	1.00000				C8077
6	구매	KM 1000uF/16V/105°C(10*16)	EA	MANYUE			1
19	E471020061-L	CAP,ELEC	1.00000				C8055
6	구매	KM 1000uF/25V/105°C(10*20)	EA	MANYUE			1
20	E472220032-L	CAP,ELEC	4.00000				C8026,46,49,143
6	구매	KM 2200uF/10V/105°C(10*20)	EA	MANYUE			1
21	E472200059-L	CAP,ELEC	1.00000				C8039
6	구매	KM 22uF/100V/105°C(6.3*11)	EA	MANYUE			1
22	E474R70031-L	CAP,ELEC	1.00000				C8083
6	구매	KM 4.7uF/25V/105°C(5*11)	EA	MANYUE			1
23	E474710084-L	CAP/AL	3.00000				C8068,92,93
6	구매	KM 470uF/25V/105°C(10*12.5)	EA	MANYUE			1
24	E474710088-L	CAP/AL	3.00000				C8044,47,78
6	구매	KM 470uF/50V/105° C (10*20)	EA	MANYUE			1
25	E474700088-L	CAP,ELEC	2.00000				C8222,224
6	구매	KM 47uF/50V/105°C(6.3*11)	EA	MANYUE			1

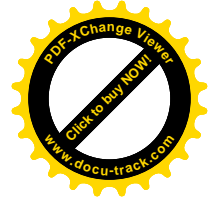
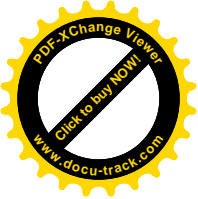

순번	자품목번호	품명	UOM	공정명	대체품 코드	대체품 품명	자재위치
Level	조달구분	규격	단위	제조사	대체품 규격	대체품 제조사	부품 PACKING 단위
26	E470100019-L	CAP,ELEC	1.00000				C8025
6	구매	RD 1uF/50V/105℃(5*11)	EA	삼화전기			1
27	E473310023-L	CAP,ELEC	1.00000				C8014
6	구매	RD 330uF/6.3V/105℃(6.3*11)	EA	삼화전기			1
28	E304000048-L	DIODE,SWITCHING	8.00000				D8009,10,11,13,14,15,24,25
6	구매	1N4007	EA	VISHAY			1
29	E301000628-L	DIODE,SWITCHING	3.00000				D8039,44,54
6	구매	1N4148	EA	ROHM			1
30	E308001127-L	DIODE/FRD	1.00000				D8052
6	구매	BYV26C	EA	VISHAY			1
31	E304000637-L	DIODE,FRD	2.00000				D8035,42
6	구매	BYV26EGP	EA	VISHAY			1
32	E304000596-L	DIODE,SBD	5.00000				D8021,43,49,62,203
6	구매	SB140	EA	VISHAY			1
33	E308001077-L	DIODE	4.00000				D8005,17,23,27
6	구매	UF4007	EA	VISHAY			1
34	E90908056-L	FUSE	1.00000				F8004
6	구매	263 001(250V/1A)	EA	Littelfuse			1
35	E90908170-L	FUSE	2.00000				F8008,9
6	구매	382 1100 (AC250V T1AL)	EA	WICKMANN			1
36	E90908171-L	FUSE	2.00000				F8003,6
6	구매	382 1315 (AC250V T3.15AL)	EA	WICKMANN			1
37	E101005339-L	IC	1.00000				IC8012
6	구매	AME8811AEATZ	EA	AME			1
38	E109004986-L	IC	1.00000				IC8023
6	구매	AZ431LAZ-E1	EA	BCD			1
39	E101029099-L	IC	8.00000				IC8006,19,21,27,33,35,36,38
6	구매	TL431A-TA	EA	(주)태진기술			1
40	E65100104-L	LED	2.00000				LED8001,2
6	구매	SM3517(F3T)	EA	광전자			1

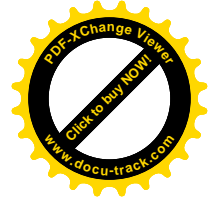
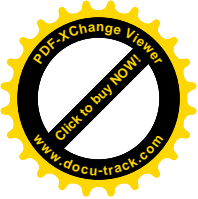

순번	자품목번호	품명	UOM	공정명	대체품 코드	대체품 품명	자재위치
Level	조달구분	규격	단위	제조사	대체품 규격	대체품 제조사	부품 PACKING 단위
41	E202002015-L	TR, PNP	1.00000				Q8004
6	구매	KTA1273-Y	EA	KEC			1
42	E202001265-L	TR, PNP	6.00000				Q8007,10,11,202,203,207
6	구매	KTA1281-Y	EA	KEC			1
43	E201001575-L	TR, NPN	4.00000				Q8005,6,201,205
6	구매	KTC3209-Y	EA	KEC			1
44	E6102R2002-L	RES, METAL	1.00000				R8313
6	구매	2.2ohm/5%/1W	EA	아벨전기(주)			1
45	E612404001-L	RES,METAL GRAZE	2.00000				R8235,267
6	구매	2.4Mohm/5%/1W/R/ABCO	EA	아벨전기(주)			1
46	E612003019-L	RES, METAL	10.00000				R8049,50,51,52,53,57,58,59,60,61
6	구매	200Kohm/5%/0.25W	EA	아벨전기(주)			1
47	E623003004-L	RES, CARBON	3.00000				R8184,185,186
6	구매	330Kohm/5%/0.5W/ABCO	EA	아벨전기(주)			1
48	E6106R8001-L	RES,METAL OXIDE	2.00000				R8211,253
6	구매	6.8ohm/5%/1W/ABCO	EA	아벨전기(주)			1
49	E619002001-L	RES,METAL OXIDE	6.00000				R8131,172,197,296,297,298
6	구매	90Kohm/5%/1W/R/ABCO	EA	아벨전기(주)			1
50	E622000016-L	RESISTOR,SURGE	1.00000				R8006
6	구매	ASR/1Mohm/5%/0.5W	EA	아진 올(A-JIN OHM)			1
51	E622000012-L	RESISTOR,SURGE	2.00000				R8001,23
6	구매	ASR/220ohm/10%/0.5W	EA	아진 올(A-JIN OHM)			1
52	E580100001-L	THERMISTOR	1.00000				RT8001
6	구매	10D/9	EA	삼경세라믹			1
53	E591002019-L	RES,VR	6.00000				VR8002,5,6,7,8,9
6	구매	25PRE 10K	EA	BI			1
54	E302002867-L	DIODE/ZENER	7.00000				ZD8201,202,203,204,232,234,236
6	구매	1N4750A(27V/1W)	EA	TAK CHEONG			1
55	E302000761-L	DIODE,ZENER	1.00000				ZD8220
6	구매	1N4746A(18V/1W)	EA	TAK CHEONG			1

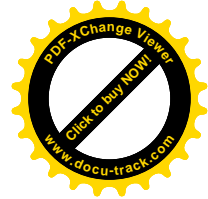
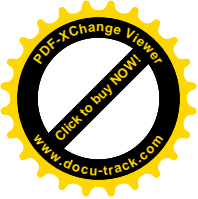

순번	자품목번호	품명	UOM	공정명	대체품 코드	대체품 품명	자재위치
Level	조달구분	규격	단위	제조사	대체품 규격	대체품 제조사	부품 PACKING 단위
56	E302002499-L	ZENERDIODE	1.00000				ZD8225
6	구매	1N5227B	EA	TAK CHEONG			1
57	E617502020-L	RES,METAL	3.00000				R8109,110,111
6	구매	75Kohm/5%/1W	EA	아벨전기(주)			1
58	E630R50004-L	RES,WIREWOUND	1.00000				R8189
6	구매	WNP 1W TC 0R5	EA	아벨전기(주)			1
59	E630R50005-L	RES,WIREWOUND	2.00000				R8226,230
6	구매	WNP 1W TC 0R54	EA	아벨전기(주)			1
60	E630R50006-L	RES,WIREWOUND	1.00000				R8150
6	구매	WNP 1W TC 1R0	EA	아벨전기(주)			1
61	E630R50007-L	RES,WIREWOUND	2.00000				R8232,8095
6	구매	WNP 1W TC 1R5	EA	아벨전기(주)			1
62	E80100059-L	VARISTOR,CHIP	2.00000				RA8001,2
6	구매	TSA-501M	EA	스마트전자(주)			1
63	E474710076-L	CAP,ELEC	2.00000				C8052,56
6	구매	KM 470uF/35V/105℃(10*16)	EA	MANYUE			1
2	E401010014-L	CAPACITOR	1.00000				C8074
5	구매	101J/0805/NPO/50V/TD	EA	TDK			1
3	E401020014-L	CAPACITOR	3.00000				C8030,80,148
5	구매	102J/0805/NPO/50V/TD	EA	TDK			1
4	E401030011-L	CAPACITOR	4.00000				C8027,221,229,235
5	구매	103K/0805/X7R/50V/TD	EA	TDK			1
5	E401040077-L	CAPACITOR	21.00000				C8015,32,58,63,64,76,82,89,102,103,107,122,118,120,121,146,147,223,230,233,236
5	구매	104K/0805/X7R/50V/TD	EA	TDK			1
6	E401050053-L	CAP.CHIP	5.00000				C8130,225,226,232,237
5	구매	105K/0805/X7R/25V/TD	EA	TDK			1
7	E402210012-L	CAPACITOR	6.00000				C8070,95,123,240,241,242
5	구매	221J/0805/NPO/50V/TD	EA	TDK			1
8	E402240032-L	CAP.CHIP	4.00000				C8065,090,119,238
5	구매	224K/0805/X7R/50V/TD	EA	TDK			1

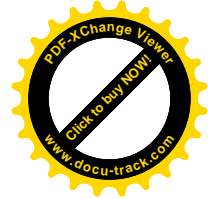
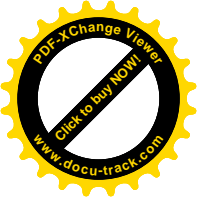

순번	자품목번호	품명	UOM	공정명	대체품 코드	대체품 품명	자재위치
Level	조달구분	규격	단위	제조사	대체품 규격	대체품 제조사	부품 PACKING 단위
9	E404710013-L	CAPACITOR	6.00000				C8031,73,75,79,81,234
5	구매	471J/0805/NPO/50V/TD	EA	TDK			1
10	E404720008-L	CAPACITOR	1.00000				C8116
5	구매	472K/0805/X7R/50V/TD	EA	TDK			1
11	E404730010-L	CAPACITOR	3.00000				C8110,125,127
5	구매	473K/0805/X7R/50V/TD	EA	TDK			1
12	E404740050-L	CAPACITOR	1.00000				C8067
5	구매	474K/0805/X7R/25V/TD	EA	TDK			1
13	E307000069-L	DIODE,FRD	3.00000				D8100,220,221
5	구매	D1FL20U	EA	SHINDENGEN			1
14	E307000039-L	DIODE,SBD	8.00000				D8007,8,12,20,55,58,59,60
5	구매	D1FS4	EA	SHINDENGEN			1
15	E307000029-L	DIODE/SBD	1.00000				D8050
5	구매	D1FS6	EA	SHINDENGEN			1
16	E201000832-L	T.R	5.00000				Q8002,9,17,18,221
5	구매	KTN2222AS	EA	KEC			1
17	E202000062-L	T.R	1.00000				Q8012
5	구매	KTN2907AS	EA	KEC			1
18	E600000016-L	RES,CHIP	8.00000				R8055,148,187,288,291,292,293,294
5	구매	CRS0R0J/1206/0.25W	EA	한룩전자(주)			1
19	E600100036-L	RES,CHIP	2.00000				R8073,144
5	구매	CRS100J/1206/0.25W	EA	한룩전자(주)			1
20	E601000108-L	RES,CHIP	6.00000				R8070,149,177,220,239,243
5	구매	CRS101J/1206/0.25W	EA	한룩전자(주)			1
21	E601001178-L	RES,CHIP	3.00000				R8206,165,264
5	구매	CRS102F/1206/0.25W	EA	한룩전자(주)			1
22	E601001179-L	RES,CHIP	24.00000				R8033,41,65,77,78,85,104,140,153,155,162,180,212,215,216,223,225,227,237,244,254,257,265,300
5	구매	CRS102J/1206/0.25W	EA	한룩전자(주)			1
23	E601001180-L	RES,CHIP	12.00000				R8075,89,98,161,166,191,199,251,258,268,054,056
5	구매	CRS103J/1206/0.25W	EA	한룩전자(주)			1

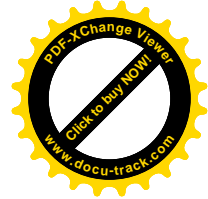
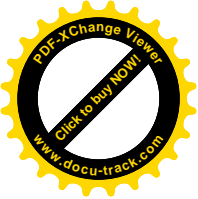

순번	자품목번호	품명	UOM	공정명	대체품 코드	대체품 품명	자재위치
Level	조달구분	규격	단위	제조사	대체품 규격	대체품 제조사	부품 PACKING 단위
24	E601003042-L	RES	1.00000				R8214
5	구매	CRS104F/1206/0.25W	EA	한룩전자(주)			1
25	E601003043-L	RES	1.00000				R8224
5	구매	CRS104J/1206/0.25W	EA	한룩전자(주)			1
26	E601201017-L	RES,CHIP	3.00000				R8029,30,143
5	구매	CRS122J/1206/0.25W	EA	한룩전자(주)			1
27	E601302010-L	RES,CHIP	1.00000				R8118
5	구매	CRS133F/1206/0.25W	EA	한룩전자(주)			1
28	E601203013-L	RES	3.00000				R8011,198,203
5	구매	CRS124F/1206/0.25W	EA	한룩전자(주)			1
29	E601500024-L	RES,CHIP	2.00000				R8124,315
5	구매	CRS151F/1206/0.25W	EA	한룩전자(주)			1
30	E601501030-L	RES,CHIP	1.00000				R8229
5	구매	CRS152F/1206/0.25W	EA	한룩전자(주)			1
31	E601502029-L	RES,CHIP	3.00000				R8299,021,260
5	구매	CRS153J/1206/0.25W	EA	한룩전자(주)			1
32	E601503021-L	RES,CHIP	6.00000				R8003,4,39,40,42,82
5	구매	CRS154F/1206/0.25W	EA	한룩전자(주)			1
33	E601503022-L	RES,CHIP	1.00000				R8064
5	구매	CRS154J/1206/0.25W	EA	한룩전자(주)			1
34	E601801024-L	RES,CHIP	2.00000				R8236,252
5	구매	CRS182J/1206/0.25W	EA	한룩전자(주)			1
35	E601802030-L	RES,CHIP	1.00000				R8238
5	구매	CRS183F/1206/0.25W	EA	한룩전자(주)			1
36	E601802031-L	RES,CHIP	1.00000				R8025
5	구매	CRS183J/1206/0.25W	EA	한룩전자(주)			1
37	E601803013-L	RES,CHIP	1.00000				R8138
5	구매	CRS184J/1206/0.25W	EA	한룩전자(주)			1
38	E600010002-L	RES,CHIP	1.00000				R8245
5	구매	CRS1R0J/1206/0.25W	EA	한룩전자(주)			1



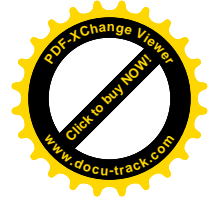
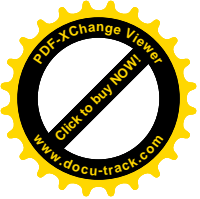

순번	자품목번호	품명	UOM	공정명	대체품 코드	대체품 품명	자재위치
Level	조달구분	규격	단위	제조사	대체품 규격	대체품 제조사	부품 PACKING 단위
39	E602000024-L	RES,CHIP	2.00000				R8129,201
5	구매	CRS201J/1206/0.25W	EA	한룩전자(주)			1
40	E602001029-L	RES,CHIP	1.00000				R8154
5	구매	CRS202F/1206/0.25W	EA	한룩전자(주)			1
41	E602001030-L	RES,CHIP	2.00000				R8014,231
5	구매	CRS202J/1206/0.25W	EA	한룩전자(주)			1
42	E602003025-L	RES,CHIP	10.00000				R8027,87,135,174,176,179,218,228,286,287
5	구매	CRS204F/1206/0.25W	EA	한룩전자(주)			1
43	E602003024-L	RES,CHIP	1.00000				R8208
5	구매	CRS204J/1206/0.25W/HANRYUK	EA	한룩전자(주)			1
44	E602200011-L	RES,CHIP	1.00000				R8217
5	구매	CRS221J/1206/0.25W	EA	한룩전자(주)			1
45	E602201025-L	RES,CHIP	7.00000				R8032,34,116,136,151,178,204
5	구매	CRS222J/1206/0.25W	EA	한룩전자(주)			1
46	E602202017-L	RES,CHIP	1.00000				R8026
5	구매	CRS223F/1206/0.25W	EA	한룩전자(주)			1
47	E602202018-L	RES,CHIP	1.00000				R8117
5	구매	CRS223J/1206/0.25W	EA	한룩전자(주)			1
48	E602203008-L	RES,CHIP	1.00000				R8200
5	구매	CRS224F/1206/0.25W	EA	한룩전자(주)			1
49	E602401013-L	RES,CHIP	2.00000				R8071,99
5	구매	CRS242F/1206/0.25W	EA	한룩전자(주)			1
50	E602402011-L	RES,CHIP	1.00000				R8100
5	구매	CRS243F/1206/0.25W	EA	한룩전자(주)			1
51	E602403014-L	RES,CHIP	2.00000				R8079,81
5	구매	CRS244F/1206/0.25W	EA	한룩전자(주)			1
52	E600270009-L	RES	1.00000				R8192
5	구매	CRS270J/1206/0.25W	EA	한룩전자(주)			1
53	E602700014-L	RES	1.00000				R8195
5	구매	CRS271J/1206/0.25W/HANRYUK	EA	한룩전자(주)			1

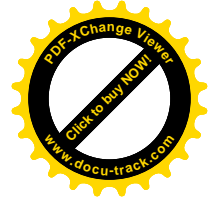
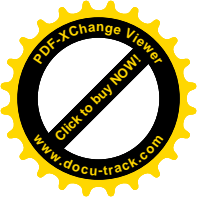

순번	자품목번호	품명	UOM	공정명	대체품 코드	대체품 품명	자재위치
Level	조달구분	규격	단위	제조사	대체품 규격	대체품 제조사	부품 PACKING 단위
54	E602701017-L	RES,CHIP	1.00000				R8107
5	구매	CRS272J/1206/0.25W	EA	한룩전자(주)			1
55	E602702020-L	RES,CHIP	2.00000				R8132,205
5	구매	CRS273J/1206/0.25W	EA	한룩전자(주)			1
56	E602703012-L	RES	5.00000				R8010,16,18,285,130
5	구매	CRS274F/1206/0.25W	EA	한룩전자(주)			1
57	E602703013-L	RES	1.00000				R8168
5	구매	CRS274J/1206/0.25W	EA	한룩전자(주)			1
58	E603001018-L	RES,CHIP	4.00000				R8262,295,157,160
5	구매	CRS302F/1206/0.25W	EA	한룩전자(주)			1
59	E603001019-L	RES,CHIP	1.00000				R8213
5	구매	CRS302J/1206/0.25W	EA	한룩전자(주)			1
60	E603002023-L	RES,CHIP	1.00000				R8114
5	구매	CRS303F/1206/0.25W	EA	한룩전자(주)			1
61	E603003019-L	RES	5.00000				R8005,8,9,15,210
5	구매	CRS304F/1206/0.25W	EA	한룩전자(주)			1
62	E600330010-L	RES,CHIP	5.00000				R8141,246,247,248,279
5	구매	CRS330J/1206/0.25W	EA	한룩전자(주)			1
63	E603301018-L	RES,CHIP	2.00000				R8139,190
5	구매	CRS332J/1206/0.25W	EA	한룩전자(주)			1
64	E603302023-L	RES,CHIP	2.00000				R8043,142
5	구매	CRS333F/1206/0.25W	EA	한룩전자(주)			1
65	E603302024-L	RES,CHIP	3.00000				R8133,240,241
5	구매	CRS333J/1206/0.25W	EA	한룩전자(주)			1
66	E603900018-L	RES,CHIP	1.00000				R8314
5	구매	CRS391F/1206/0.25W	EA	한룩전자(주)			1
67	E603900019-L	RES,CHIP	1.00000				R8152
5	구매	CRS391J/1206/0.25W	EA	한룩전자(주)			1
68	E604300010-L	RES,CHIP	2.00000				R8128,263
5	구매	CRS431J/1206/0.25W	EA	한룩전자(주)			1

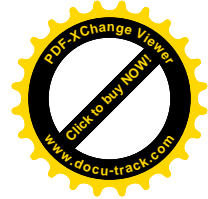
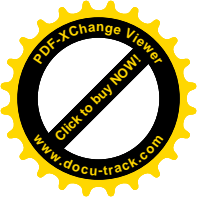

순번	자품목번호	품명	UOM	공정명	대체품 코드	대체품 품명	자재위치
Level	조달구분	규격	단위	제조사	대체품 규격	대체품 제조사	부품 PACKING 단위
69	E600470019-L	RES,CHIP	8.00000				R8080,134,175,202,270,275,276,277
5	구매	CRS470J/1206/0.25W	EA	한룩전자(주)			1
70	E604700028-L	RES,CHIP	5.00000				R8020,31,108,122,209
5	구매	CRS471J/1206/0.25W	EA	한룩전자(주)			1
71	E604701030-L	RES,CHIP	3.00000				R8083,115,274
5	구매	CRS472F/1206/0.25W	EA	한룩전자(주)			1
72	E604701031-L	RES,CHIP	6.00000				R8045,97,113,163,256,266
5	구매	CRS472J/1206/0.25W	EA	한룩전자(주)			1
73	E604702026-L	RES,CHIP	3.00000				R8169,278,316
5	구매	CRS473J/1206/0.25W	EA	한룩전자(주)			1
74	E6004R7018-L	RES,CHIP	1.00000				R8269
5	구매	CRS4R7J/1206/0.25W	EA	한룩전자(주)			1
75	E605100016-L	RES,CHIP	1.00000				R8159
5	구매	CRS511J/1206/0.25W	EA	한룩전자(주)			1
76	E605101017-L	RES	1.00000				R8017
5	구매	CRS512F/1206/0.25W	EA	한룩전자(주)			1
77	E605103022-L	RES,CHIP	1.00000				R8242
5	구매	CRS514J/1206/0.25W	EA	한룩전자(주)			1
78	E605600018-L	RES,CHIP	1.00000				R8282
5	구매	CRS561F/1206/0.25W	EA	한룩전자(주)			1
79	E605600019-L	RES,CHIP	1.00000				R8171
5	구매	CRS561J/1206/0.25W	EA	한룩전자(주)			1
80	E605601018-L	RES	6.00000				R8048,72,86,102,105,233
5	구매	CRS562J/1206/0.25W/HANRYUK	EA	한룩전자(주)			1
81	E606800020-L	RES,CHIP	3.00000				R8145,181,221
5	구매	CRS681J/1206/0.25W	EA	한룩전자(주)			1
82	E606801020-L	RES,CHIP	3.00000				R8156,183,234
5	구매	CRS682F/1206/0.25W	EA	한룩전자(주)			1
83	E606801021-L	RES,CHIP	3.00000				R8146,182,219
5	구매	CRS682J/1206/0.25W	EA	한룩전자(주)			1

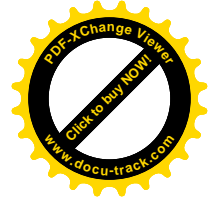
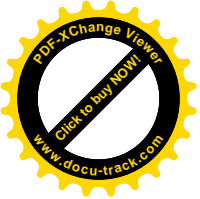

순번	자품목번호	품명	UOM	공정명	대체품 코드	대체품 품명	자재위치
Level	조달구분	규격	단위	제조사	대체품 규격	대체품 제조사	부품 PACKING 단위
84	E606802015-L	RES,CHIP	3.00000				R8088,93,103
5	구매	CRS683J/1206/0.25W	EA	한룩전자(주)			1
85	E606803008-L	RES,CHIP	1.00000				R8024
5	구매	CRS684F/1206/0.25W	EA	한룩전자(주)			1
86	E607501019-L	RES,CHIP	2.00000				R8147,222
5	구매	CRS752F/1206/0.25W	EA	한룩전자(주)			1
87	E607503002-L	RES,CHIP	1.00000				R8091
5	구매	CRS754F/1206/0.25W	EA	한룩전자(주)			1
88	E609100012-L	RES,CHIP	1.00000				R8164
5	구매	CRS911F/1206/0.25W	EA	한룩전자(주)			1
89	E609103008-L	RES,CHIP	1.00000				R8092
5	구매	CRS914F/1206/0.25W	EA	한룩전자(주)			1
90	E609103009-L	RES,CHIP	1.00000				R8094
5	구매	CRS914J/1206/0.25W	EA	한룩전자(주)			1
91	E101000192-L	I.C	1.00000				U8003
5	구매	NJM2903M	EA	J.R.C			1
92	E101000202-L	I.C	1.00000				U8005
5	구매	NJM2904M	EA	J.R.C			1
93	E302002932-L	DIODE/ZENER	8.00000				ZD8226,227,228,229,230,231,233,235
5	구매	MMSZ5227BT1G(3.6V)	EA	ON SEMI			1
					E302003272-L	DIODE/ZENER	
					MMSZ5227B	PAN JIT INTL INC(TW)	
94	E302002942-L	DIODE/ZENER	1.00000				ZD8003
5	구매	MMSZ5231BT1G(5.1V)	EA	ON SEMI			1
					E302003252-L	DIODE/ZENER	
					MMSZ5231B	DIODES INC.	
95	E302002934-L	DIODE/ZENER	1.00000				ZD8223
5	구매	MMSZ5235BT1G(6.8V)	EA	ON SEMI			1
					E302003282-L	DIODE/ZENER	
					MMSZ5235B	PAN JIT INTL INC(TW)	

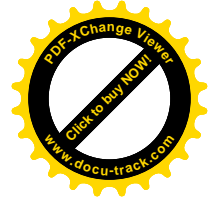
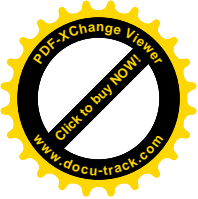

순번	자품목번호	품명	UOM	공정명	대체품 코드	대체품 품명	자재위치
Level	조달구분	규격	단위	제조사	대체품 규격	대체품 제조사	부품 PACKING 단위
96	E302002962-L	DIODE/ZENER	2.00000				ZD8101,102
5	구매	MMSZ5241BT1G(11V)	EA	ON SEMI			1
					E302003292-L	DIODE/ZENER	
					MMSZ5241B	PAN JIT INTL INC(TW)	
97	E302002972-L	DIODE/ZENER	3.00000				ZD8004,5,205
5	구매	MMSZ5245BT1G(15V)	EA	ON SEMI			1
					E302002714-L	D.D	
					MMSZ5245B(15V)	DIODES INC.	
98	E302002982-L	DIODE/ZENER	1.00000				ZD8222
5	구매	MMSZ5254BT1G(27V)	EA	ON SEMI			1
					E302003302-L	DIODE/ZENER	
					MMSZ5254B	PAN JIT INTL INC(TW)	
99	E401030053-L	CAPACITOR	1.00000				C8112
5	구매	103K/0805/X7R/100V/TD	EA	TDK			1
100	E6003R3006-L	RES,CHIP	1.00000				R8007
5	구매	CRS3R3F/1206/0.25W	EA	한룩전자(주)			1
101	E606800021-L	RES,CHIP	14.00000				R8301,2,3,4,5,6,7,8,9,10,11,12,319,320
5	구매	CRS680F/1206/0.25W	EA	한룩전자(주)			1
102	E602200011-L	RES,CHIP	1.00000				R8022
5	구매	CRS221J/1206/0.25W	EA	한룩전자(주)			1
103	E603300019-L	RES.CHIP	1.00000				R8037
5	구매	CRS331F/1206/0.25W	EA	한룩전자(주)			1
104	E604702027-L	RES,CHIP	2.00000				R8317,8318
5	구매	CRS473F/1206/0.25W	EA	한룩전자(주)			1
2	E304000669-L	DIODE,FRD	1.00000				D8047
4	구매	FSF10A20	EA	N.I			1
3	E308001239-L	DIODE	1.00000				D8037
4	구매	SF304C	EA	RECTRON			1
4	E308001209-L	DIODE	1.00000				D8003
4	구매	STTH12R06FP	EA	ST MICRO-ELECTRONICS			1

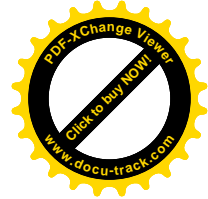
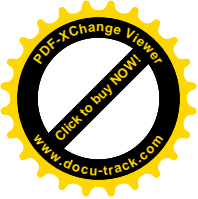

순번	자품목번호	품명	UOM	공정명	대체품 코드	대체품 품명	자재위치
Level	조달구분	규격	단위	제조사	대체품 규격	대체품 제조사	부품 PACKING 단위
5	E308001219-L	DIODE/FRD	1.00000				D8004
4	구매	STTH15R06FP	EA	ST MICRO-ELECTRONICS			1
6	E308001199-L	DIODE/FRD	4.00000				D8026,30,45,53
4	구매	STTH2003CFP	EA	ST MICRO-ELECTRONICS			1
7	E308001249-L	DIODE/FRD	2.00000				D8033,41
4	구매	FSF10A40	EA	N.I			1
8	E703203190-L	HEATSINK	1.00000				H8001
4	구매	131*35*25,BD(PS-PHV4)	EA	도성정밀			1
					E703203200-L	HEATSINK	
					131*35*25,BD(PS-PHV4)	정승오금	
					E703203210-L	HEATSINK	
					131*35*25,BD(PS-PHV4)	(주)미경스크린	
9	E703202890-L	HEATSINK	1.00000				H8002
4	구매	156.1*35*32,PFC(PS-PHV4)	EA	도성정밀			1
					E703202910-L	HEATSINK	
					156.1*35*32,PFC(PS-PHV4)	정승오금	
					E703202900-L	HEATSINK	
					156.1*35*32,PFC(PS-PHV4)	(주)미경스크린	
10	E703202920-L	HEATSINK	1.00000				H8004
4	구매	61*35*32,LC(PS-PHV4)	EA	도성정밀			1
					E703202940-L	HEATSINK	
					61*35*32,LC(PS-PHV4)	정승오금	
					E703202930-L	HEATSINK	
					61*35*32,LC(PS-PHV4)	(주)미경스크린	
11	E703202950-L	HEATSINK	1.00000				H8005
4	구매	116*35*32,VS_D(PS-PHV4)	EA	도성정밀			1
					E703202970-L	HEATSINK	
					116*35*32,VS_D(PS-PHV4)	정승오금	
					E703202960-L	HEATSINK	
					116*35*32,VS_D(PS-PHV4)	(주)미경스크린	

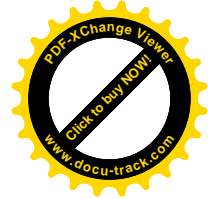
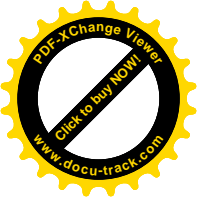

순번	자품목번호	품명	UOM	공정명	대체품 코드	대체품 품명	자재위치
Level	조달구분	규격	단위	제조사	대체품 규격	대체품 제조사	부품 PACKING 단위
12	E703202980-L	HEATSINK	1.00000				H8006
4	구매	91*35*32,IMG(PS-424-PHV4)	EA	도성정밀			1
					E703203000-L	HEATSINK	
					91*35*32,IMG(PS-424-PHV4)	정승오금	
					E703202990-L	HEATSINK	
					91*35*32,IMG(PS-424-PHV4)	(주)미경스크린	
13	E703203010-L	HEATSINK	1.00000				H8007
4	구매	156*35*32,VS(PS-PHV4)	EA	도성정밀			1
					E703203030-L	HEATSINK	
					156*35*32,VS(PS-PHV4)	정승오금	
					E703203020-L	HEATSINK	
					156*35*32,VS(PS-PHV4)	(주)미경스크린	
14	E703203040-L	HEATSINK	3.00000				H8009,10,11
4	구매	15*11*30(PS-PHV4)	EA	도성정밀			1
					E703203060-L	HEATSINK	
					15*11*30(PS-PHV4)	정승오금	
					E703203050-L	HEATSINK	
					15*11*30(PS-PHV4)	(주)미경스크린	
15	E703203160-L	HEATSINK	1.00000				H8012
4	구매	15*11*30*12,IMG(PS-PHV4)	EA	도성정밀			1
					E703203180-L	HEATSINK	
					15*11*30*12,IMG(PS-PHV4)	정승오금	
					E703203170-L	HEATSINK	
					15*11*30*12,IMG(PS-PHV4)	(주)미경스크린	
16	E109004959-L	IC	1.00000				IC8028
4	구매	F9222L	EA	FUJI			1
17	E109004989-L	IC	3.00000				IC8015,24,29
4	구매	STR-G6353	EA	SANKEN			1
18	E203001639-L	FET	2.00000				Q8015,16
4	구매	2SK3679-01MR	EA	FUJI			1

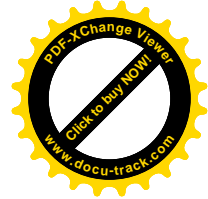
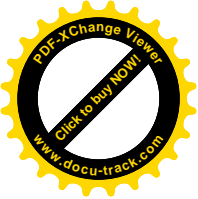

순번	자품목번호	품명	UOM	공정명	대체품 코드	대체품 품명	자재위치
Level	조달구분	규격	단위	제조사	대체품 규격	대체품 제조사	부품 PACKING 단위
19	E203001646-L	FET	1.00000				Q8220
4	구매	STP80PF55	EA	ST MICRO-ELECTRONICS			1
20	E203001459-L	FET	2.00000				Q8001,3
4	구매	IXFH26N60Q	EA	IXYS CORPORATION.			1
21	E90900381-L	SILICONGREASE	1.00000				
4	구매	SE-4490CV	GM	DOWCORNING			1
22	E90900021-L	WASHER,PLASTIC	5.00000				
4	구매	TR(SMALL)	EA	시장구매			1
23	E90908164-L	CLAMP	1.00000				
4	구매	87.5*7*16.3	EA	도성정밀			1
					E90908175-L	CLAMP	
					87.5*7*16.3	정승오금	
					E90908165-L	CLAMP	
					87.5*7*16.3	(주)미경스크린	
24	E90908168-L	CLAMP	1.00000				
4	구매	2.0t*22*8	EA	도성정밀			1
					E90908174-L	CLAMP	
					2.0t*22*8	정승오금	
					E90908169-L	CLAMP	
					2.0t*22*8	(주)미경스크린	
25	E90900432-L	COOLSHEET	1.00000				
4	구매	SP900SAC-29*155	EA	(유)버쿼스트컴퍼니코리아			1
26	E90900434-L	COOLSHEET	1.00000				
4	구매	SP900SAC-36*155, 6HOLE	EA	(유)버쿼스트컴퍼니코리아			1
27	E90900433-L	COOLSHEET	1.00000				
4	구매	SP900SAC-36*155, 5HOLE	EA	(유)버쿼스트컴퍼니코리아			1
28	E90900436-L	COOLSHEET	5.00000				
4	구매	TO-220H-S9(13*18)	EA	(유)버쿼스트컴퍼니코리아			1
29	E90900284-L	COOLSHEET	1.00000				
4	구매	TO-3PH-S9	EA	APEX			1



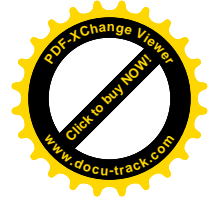
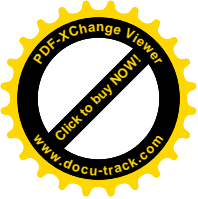

순번	자품목번호	품명	UOM	공정명	대체품 코드	대체품 품명	자재위치
Level	조달구분	규격	단위	제조사	대체품 규격	대체품 제조사	부품 PACKING 단위
30	E700001690-L	SCREW	20.00000				
4	구매	+PAN M3*P0.5-8.0L S/W P/W NI/P	EA	시장구매			1
31	E700002180-L	SCREW	7.00000				
4	구매	+PAN M3*10L S/W P/W NI/P	EA	(주)아세아볼트			1
32	E700001520-L	SCREW+PAN	4.00000				
4	구매	M3*12L sems screw (F/S) NI_PLATE	EA	시장구매			1
33	E203001679-L	FET	1.00000				Q8008
4	구매	STP6NK90ZFP	EA	ST MICRO-ELECTRONICS			1
34	E75120399-L	PCB	1.00000				
4	구매	380*245*1.6t (PHV4_42/101C)_ECO	EA	(주)다빈			1
					E75120398-L	PCB	
					380*245*1.6t (PHV4_42/101C)_ECO	대진전자	
					E75120400-L	PCB	
					380*245*1.6t (PHV4_42/101C)_ECO	현우산업(주)	
35	E303000269-L	DIODE/BRIDGE	1.00000				D8006
4	구매	RS1505M	EA	RECTRON			1
36	E203001689-L	FET	2.00000				Q8020,22
4	구매	IXTQ22N60P	EA	IXYS CORPORATION.			1
37	E101005089-L	IC	2.00000				IC8026,41
4	구매	LM2576TV-ADJG	EA	(주)태진기술			1
38	E101004429-L	I.C	2.00000				IC8013,14
4	구매	LM2576TV-5G	EA	(주)태진기술			1
39	E431040030-L	CAP/FILM	3.00000				C8228,012,001
4	구매	104K 630V S 403 MPE	EA	성호전자			1
40	E432230008-L	CAP	1.00000				C8097
4	구매	HHC630V223J	EA	OKAYA			1
41	E471010068-L	CAP/AL	1.00000				C8106
4	구매	KM 100uF/160V/105°C(12.5*25)	EA	MANYUE			1
42	E474700080-L	CAP,ELEC	2.00000				C8050,84
4	구매	KM 47uF/350V/105°C(16*25)	EA	MANYUE			1

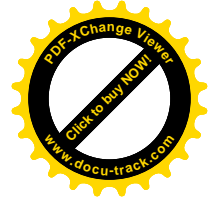
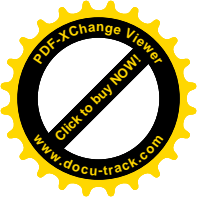

순번	자품목번호	품명	UOM	공정명	대체품 코드	대체품 품명	자재위치
Level	조달구분	규격	단위	제조사	대체품 규격	대체품 제조사	부품 PACKING 단위
43	E431050022-L	CAP.FILM	3.00000				C8008,87,88
4	구매	105J/630V/105℃ MP (27.5mm)-M	EA	명성콘덴서(주)			1
44	E432250010-L	CAP/FILM	1.00000				C8101
4	구매	225J/150V/105℃ MP (22.5mm)-M	EA	명성콘덴서(주)			1
45	E433350004-L	CAP.FILM	1.00000				C8100
4	구매	335J/150V/105℃ MP (22.5mm)-M	EA	명성콘덴서(주)			1
46	E434740017-L	CAP.FILM	1.00000				C8009
4	구매	474J/630V/105℃ MP (22.5mm)-M	EA	명성콘덴서(주)			1
47	E422210017-L	CAP	1.00000				C8013
4	구매	SD B 2G 221K 08 FF1(221K/Y1)	EA	삼화콘덴서			1
48	E424710014-L	C-CAPACITOR	2.00000				C8002,11
4	구매	SD B 2G 471K 08 FF1(471K/Y1)	EA	삼화콘덴서			1
49	E473320008-L	ELETROLYTIC CAP.	2.00000				C8059,60
4	구매	WB1A338M12025(3300uF/10V)	EA	삼화전기			1
50	E476810017-L	CAP/AL	5.00000				C8037,42,53,54,91
4	구매	WB 680uF/50V/105℃(12.5*25)	EA	삼화전기			1
51	E473300040-L	ELETROLYTIC CAP.	1.00000				C8028
4	구매	WL 33uF/450V/105℃(16*31.5)	EA	삼화전기			1
52	E474700071-L	CAP,ELEC	1.00000				C8057
4	구매	WL 47uF/450V/105℃(18*31.5)	EA	삼화전기			1
53	E86210248-L	CONNECTOR	1.00000				CN1M02
4	구매	B7B-PH-K-S	EA	JST			1
54	E86210222-L	CONNECTOR	1.00000				CN1M03
4	구매	B10B-PH-K-S	EA	JST			1
55	E86210223-L	CONNECTOR	1.00000				CN1M10
4	구매	B4B-PH-K-S	EA	JST			1
56	E86210225-L	CONNECTOR	1.00000				CN1M46
4	구매	B11B-PH-K-S	EA	JST			1
57	E86210178-L	CONNECTOR	1.00000				CN8001
4	구매	B2P3-VH	EA	JST			1

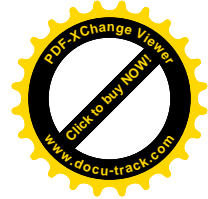
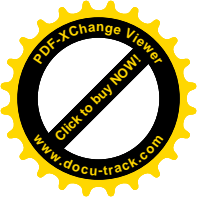

순번	자품목번호	품명	UOM	공정명	대체품 코드	대체품 품명	자재위치
Level	조달구분	규격	단위	제조사	대체품 규격	대체품 제조사	부품 PACKING 단위
58	E86210237-L	CONNECTOR	1.00000				CN8002
4	구매	35313-0960	EA	MOLEX			1
59	E86210230-L	CONNECTOR	1.00000				CN8003
4	구매	35313-1060	EA	MOLEX			1
60	E86210232-L	CONNECTOR	2.00000				CN8004,5
4	구매	35313-0560	EA	MOLEX			1
61	E86210231-L	CONNECTOR	1.00000				CN8006
4	구매	35312-1060	EA	MOLEX			1
62	E304000048-L	DIODE,SWITCHING	1.00000				D8061
4	구매	1N4007	EA	VISHAY			1
63	E307000207-L	DIODE,SBD	2.00000				D8034,56
4	구매	SB540	EA	VISHAY			1
64	E304000467-L	DIODE	2.00000				D8019,31
4	구매	SB560	EA	VISHAY			1
65	E308001209-L	DIODE	1.00000				D8002
4	구매	STTH12R06FP	EA	ST MICRO-ELECTRONICS			1
66	E308001077-L	DIODE	7.00000				D8029,32,36,38,16,18,22
4	구매	UF4007	EA	VISHAY			1
67	E90908049-L	FUSE	1.00000				F8002
4	구매	215 001(250V/1A)	EA	Littelfuse			1
68	E90908050-L	FUSE	1.00000				F8005
4	구매	215 002(250V/2A)	EA	Littelfuse			1
69	E90907971-L	FUSE	1.00000				F8007
4	구매	215 004(250V/4A)	EA	Littelfuse			1
70	E90907972-L	FUSE	1.00000				F8001
4	구매	215 008(250V/8A)	EA	Littelfuse			1
71	E90900390-L	Fuse Holder	4.00000				F8001,2,5,7
4	구매	FB58(20mm)	EA	Littelfuse			1
72	E101005319-L	IC	2.00000				IC8034,007
4	구매	KIA7815	EA	KEC			1

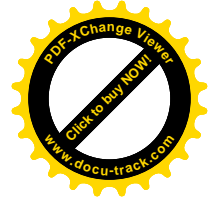
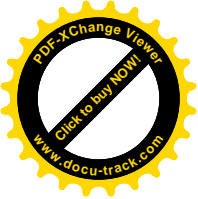

순번	자품목번호	품명	UOM	공정명	대체품 코드	대체품 품명	자재위치
Level	조달구분	규격	단위	제조사	대체품 규격	대체품 제조사	부품 PACKING 단위
73	E109005046-L	IC	1.00000				IC8003
4	구매	NCP1200AP100G	EA	ON SEMI			1
74	E109005106-L	I.C	2.00000				IC8016,17
4	구매	NCP1207PG	EA	ON SEMI			1
75	E652000198-L	PHOTO COUPLER	5.00000				IC8011,01,05,09,10
4	구매	TCET1109	EA	VISHAY			1
76	E8621194-L	CONNECTOR	2.00000				J8003,4
4	구매	PH01-02SSG	EA	PLASTRON			1
77	E50900128-L	INDUCTOR	4.00000				L8003,8,10,14
4	구매	L8003,8,10,14PH-V4(21Phi CS203075)	EA	경인전자			1
					E50900129-L	INDUCTOR	
					L8003,8,10,14PH-V4(21Phi CS203075)	동흥전자(주)	
					E50900130-L	INDUCTOR	
					L8003,8,10,14PH-V4(21Phi CS203075)	크로바하이텍(주)	
78	E50900143-L	INDUCTOR	1.00000				L8004
4	구매	L8004PH-V4(23Phi PFC CS229026)/Rev0.65	EA	경인전자			1
					E50900144-L	INDUCTOR	
					L8004PH-V4(23Phi PFC CS229026)/Rev0.65	동흥전자(주)	
					E50900145-L	INDUCTOR	
					L8004PH-V4(23Phi PFC CS229026)/Rev0.65	크로바하이텍(주)	
79	E50900134-L	INDUCTOR	2.00000				L8007,9
4	구매	L8007,9,PH-V4(3A AR6*20)	EA	경인전자			1
					E50900135-L	INDUCTOR	
					L8007,9,PH-V4(3A AR6*20)	동흥전자(주)	
					E50900136-L	INDUCTOR	
					L8007,9,PH-V4(3A AR6*20)	크로바하이텍(주)	
80	E50900137-L	INDUCTOR	1.00000				L8015
4	구매	L8015PH-V4(VS EER2834)	EA	경인전자			1
					E50900138-L	INDUCTOR	
					L8015PH-V4(VS EER2834)	동흥전자(주)	

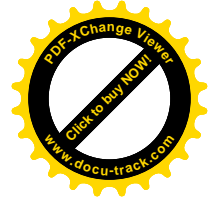
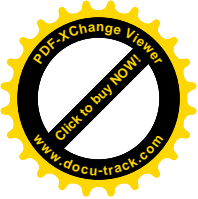

순번	자품목번호	품명	UOM	공정명	대체품 코드	대체품 품명	자재위치
Level	조달구분	규격	단위	제조사	대체품 규격	대체품 제조사	부품 PACKING 단위
					E50900139-L	INDUCTOR	
					L8015PH-V4(VS EER2834)	크로바하이텍(주)	
81	E50900140-L	INDUCTOR	1.00000				L8016
4	구매	L8016PH-V4(5A AR6*30)	EA	경인전자			1
					E50900141-L	INDUCTOR	
					L8016PH-V4(5A AR6*30)	동흥전자(주)	
					E50900142-L	INDUCTOR	
					L8016PH-V4(5A AR6*30)	크로바하이텍(주)	
82	E202002002-L	TR	1.00000				Q8013
4	구매	KTB1151	EA	KEC			1
83	E611003020-L	RES,METAL OXIDE	2.00000				R8044,47
4	구매	100Kohm/5%/1W/M/ABCO	EA	아벨전기(주)			1
84	E621503008-L	RES, CARBON	1.00000				R8127
4	구매	150Kohm/5%/3W	EA	아벨전기(주)			1
85	E611001016-L	RES,METAL	4.00000				R8036,38,121,123
4	구매	1K/5%/3W/R-FORMING	EA	아벨전기(주)			1
86	E615602004-L	RES,MOR	4.00000				R8125,173,283,284
4	구매	56Kohm/5%/3W/M-forming	EA	아벨전기(주)			1
87	E612702013-L	RES,METAL OXIDE	1.00000				R8273
4	구매	27Kohm/5%/3W/M/ABCO	EA	아벨전기(주)			1
88	E613902013-L	RES,METAL OXIDE	1.00000				R8119
4	구매	39Kohm/5%/3W/M/ABCO	EA	아벨전기(주)			1
89	E614700014-L	RES,METAL OXIDE	1.00000				R8249
4	구매	470ohm/5%/3W/ABCO	EA	아벨전기(주)			1
91	E614700016-L	RES,MOR	1.00000				R8250
4	구매	470ohm/5%/3W/R-forming	EA	아벨전기(주)			1
92	E613302021-L	RES,MOR	2.00000				R8035,126
4	구매	33Kohm/5%/3W/R-forming	EA	아벨전기(주)			1
94	E645101001-L	RES,CEMENT	1.00000				R8272
4	구매	RQR-05 5.1KJ	EA	한미정밀전자			1

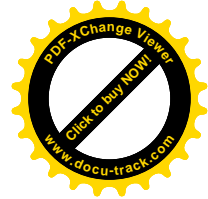
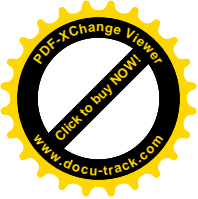

순번	자품목번호	품명	UOM	공정명	대체품 코드	대체품 품명	자재위치
Level	조달구분	규격	단위	제조사	대체품 규격	대체품 제조사	부품 PACKING 단위
95	E6406R8006-L	RES,CEMENT	1.00000				R8013
4	구매	RQR-07 6.8J	EA	(주)에치엠알			1
96	E621801006-L	RES	1.00000				R8120
4	구매	1.8Kohm/5%/3W/M/ABCO	EA	아벨전기(주)			1
97	E640R01002-L	RES,CEMENT	2.00000				R8019,194
4	구매	MPR-05RS 0.01ohm/5%	EA	한미정밀전자			1
98	E640R30002-L	RES,CEMENT	2.00000				R8158,167
4	구매	MPR-05RS 0.3ohm/5%	EA	한미정밀전자			1
99	E90500019-L	RELAY	2.00000				RLY8001,2
4	구매	SDT-S-105DMR	EA	TYCO ELECTRONICS H.K.LTD.			1
100	E580150001-L	THERMISTOR	1.00000				RT8002
4	구매	DSC 20D-15	EA	디에스씨전자(주)			1
101	E55100288-L	TRANSFORMER	1.00000				T8001
4	구매	T8001PH-V4(Vsb EE1927)	EA	경인전자			1
					E55100289-L	TRANSFORMER	
					T8001PH-V4(Vsb EE1927)	동흥전자(주)	
					E55100290-L	TRANSFORMER	
					T8001PH-V4(Vsb EE1927)	크로바하이텍(주)	
102	E55100291-L	TRANSFORMER	1.00000				T8002
4	구매	T8002PH-V4(Vcc EER2834)	EA	경인전자			1
					E55100292-L	TRANSFORMER	
					T8002PH-V4(Vcc EER2834)	동흥전자(주)	
					E55100293-L	TRANSFORMER	
					T8002PH-V4(Vcc EER2834)	크로바하이텍(주)	
103	E55100294-L	TRANSFORMER	1.00000				T8003
4	구매	T8003PH-V4(Vsemi EER2834)	EA	경인전자			1
					E55100295-L	TRANSFORMER	
					T8003PH-V4(Vsemi EER2834)	동흥전자(주)	
					E55100296-L	TRANSFORMER	
					T8003PH-V4(Vsemi EER2834)	크로바하이텍(주)	

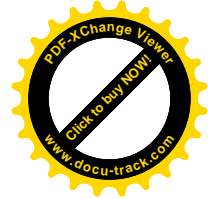
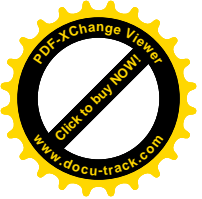

순번	자품목번호	품명	UOM	공정명	대체품 코드	대체품 품명	자재위치
Level	조달구분	규격	단위	제조사	대체품 규격	대체품 제조사	부품 PACKING 단위
104	E55100297-L	TRANSFORMER	1.00000				T8004
4	구매	T8004PH-V4(Vset EE2525)	EA	경인전자			1
					E55100298-L	TRANSFORMER	
					T8004PH-V4(Vset EE2525)	동흥전자(주)	
					E55100299-L	TRANSFORMER	
					T8004PH-V4(Vset EE2525)	크로바하이텍(주)	
105	E55100300-L	TRANSFORMER	1.00000				T8005
4	구매	T8005PH-V4(Vscan EE2525)	EA	경인전자			1
					E55100301-L	TRANSFORMER	
					T8005PH-V4(Vscan EE2525)	동흥전자(주)	
					E55100302-L	TRANSFORMER	
					T8005PH-V4(Vscan EE2525)	크로바하이텍(주)	
106	E55100303-L	TRANSFORMER	1.00000				T8006
4	구매	T8006PH-V4(Va EE4242)	EA	경인전자			1
					E55100304-L	TRANSFORMER	
					T8006PH-V4(Va EE4242)	동흥전자(주)	
					E55100305-L	TRANSFORMER	
					T8006PH-V4(Va EE4242)	크로바하이텍(주)	
107	E55100306-L	TRANSFORMER	1.00000				T8007
4	구매	T8007PH-V4(Vs EER4950)	EA	경인전자			1
					E55100307-L	TRANSFORMER	
					T8007PH-V4(Vs EER4950)	동흥전자(주)	
					E55100308-L	TRANSFORMER	
					T8007PH-V4(Vs EER4950)	크로바하이텍(주)	
108	E55100309-L	TRANSFORMER	1.00000				T8009
4	구매	T8009PH-V4(Ve EE2525)	EA	경인전자			1
					E55100310-L	TRANSFORMER	
					T8009PH-V4(Ve EE2525)	동흥전자(주)	
					E55100311-L	TRANSFORMER	
					T8009PH-V4(Ve EE2525)	크로바하이텍(주)	

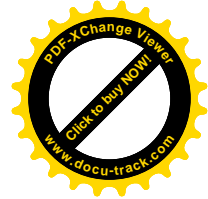
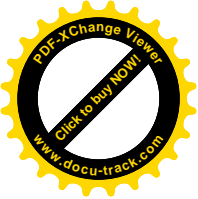

순번	자품목번호	품명	UOM	공정명	대체품 코드	대체품 품명	자재위치
Level	조달구분	규격	단위	제조사	대체품 규격	대체품 제조사	부품 PACKING 단위
109	E55100321-L	TRANSFORMER	1.00000				T8201
4	구매	T8201PH-V4(Vdrv EE1312)_7	EA	경인전자			1
					E55100322-L	TRANSFORMER	
					T8201PH-V4(Vdrv EE1312)_7	동흥전자(주)	
					E55100323-L	TRANSFORMER	
					T8201PH-V4(Vdrv EE1312)_7	크로바하이텍(주)	
110	E302002867-L	DIODE/ZENER	4.00000				ZD8001,2,200,100
4	구매	1N4750A(27V/1W)	EA	TAK CHEONG			1
111	E90900435-L	SILICON	5.00000				
4	구매	3-1944 RTV	GM	DOWCORNING			1
112	E304000757-L	DIODE	1.00000				D8001
4	구매	1N5408-M	EA	VISHAY			1
113	E50900146-L	INDUCTOR	1.00000				L8002
4	구매	L8002PH-V4(PFC EER4950)_7	EA	경인전자			1
					E50900147-L	INDUCTOR	
					L8002PH-V4(PFC EER4950)_7	동흥전자(주)	
114	E612203009-L	RES, METAL	1.00000				R8002
4	구매	220Kohm/5%/3W-M	EA	아벨전기(주)			1
115	E6406R8022-L	RES/CEMENT	1.00000				R8012
4	구매	RCT071N 6R8 J 144 SMT	EA	스마트전자(주)			1
116	E50900148-L	INDUCTOR	2.00000				L8005,6
4	구매	DV505140BS	EA	TNC			1
117	E431050023-L	CAP.FILM	1.00000				C8003
4	구매	LE474	EA	OKAYA			1
118	E431050017-L	CAP,FILM	2.00000				C8004,5
4	구매	LE105	EA	OKAYA			1
119	E80100060-L	VARISTOR	1.00000				SA8001
4	구매	20S681K	EA	JOYIN			1
120	E472210066-L	CAP/AL	2.00000				C8007,10
4	구매	HE 220uF/450V/105℃(30*40)	EA	삼화전기			1



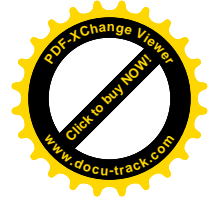
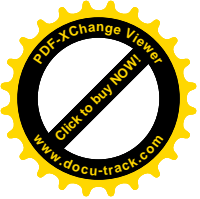

순번	자품목번호	품명	UOM	공정명	대체품 코드	대체품 품명	자재위치
Level	조달구분	규격	단위	제조사	대체품 규격	대체품 제조사	부품 PACKING 단위
121	E474710089-L	CAP/AL	2.00000				C8098,99
4	구매	HP 470uF/315V/105℃(30*40)	EA	MANYUE			1
122	E474710090-L	CAP/AL	3.00000				C8105,108,231
4	구매	KM 470uF/100V/105℃(16*30)	EA	MANYUE			1
123	E65200046-L	PHOTOCOUPLER	10.00000				IC8004,18,20,22,25,30,31,32,37,300
4	구매	LTV-817BN	EA	LITEON			1
124	E307001259-L	DIODE/FRD	2.00000				D8046,48
4	구매	FCU20A40	EA	N.I			1
125	E307001249-L	DIODE/FRD	1.00000				D8040
4	구매	MBRF1560CT	EA	VISHAY			1
2	D05PS4015681	PDP	1.00000	E/T			
3	제작	PS-424-PH(101C)	EA				1
1	D05PS4015681A	PDP	1.00000	E/T			
4	제작	PS-424-PH(101C)/ALARM	EA				1
1	D05PS4015681A8	PDP	1.00000	ASY-3			
5	제작	PS-424-PH(101C)/ALARM	EA				1
1	D05PS4015681A4	PDP	1.00000	ASY-1			
6	제작	PS-424-PH(101C)/ALARM	EA				1
1	E401040077-L	CAPACITOR	19.00000				BC8240,902,904,905,906,907,908,909,910,911,912,913,914,915,916,917,918,919,920
7	구매	104K/0805/X7R/50V/TD	EA	TDK			1
2	E471000063-L	CAP, ELEC	2.00000				BC8901,903
7	구매	RC 10uF/35V/105℃(5*5.3)	EA	삼화전기			1
3	E301000952-L	DIODE	6.00000				BD8901,2,4,5,6,7
7	구매	KDS184	EA	KEC			1
4	E65100103-L	LED	1.00000				BD8903
7	구매	SM1316	EA	광전자			1
5	E201000832-L	T.R	2.00000				BQ8240,902
7	구매	KTN2222AS	EA	KEC			1
6	E202000062-L	T.R	1.00000				BQ8901
7	구매	KTN2907AS	EA	KEC			1

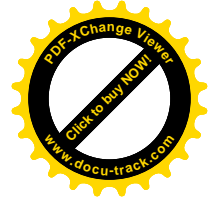
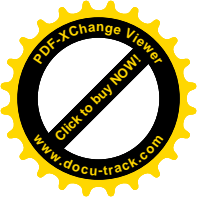

순번	자품목번호	품명	UOM	공정명	대체품 코드	대체품 품명	자재위치
Level	조달구분	규격	단위	제조사	대체품 규격	대체품 제조사	부품 PACKING 단위
7	E6000R0013-L	RES,CHIP	2.00000				BR8906,907
7	구매	0R0J/0805/0.1W/HANRYUK	EA	한룩전자(주)			1
8	E601001029-L	RES,CHIP	4.00000				BR8903,19,24,27
7	구매	102J/0805/0.1W/HANRYUK	EA	한룩전자(주)			1
9	E601002037-L	RES,CHIP	5.00000				BR8241,243,904,905,915
7	구매	103J/0805/0.1W/HANRYUK	EA	한룩전자(주)			1
10	E601003032-L	RES,CHIP	1.00000				BR8901
7	구매	104J/0805/0.1W/HANRYUK	EA	한룩전자(주)			1
11	E601502019-L	RES,CHIP	1.00000				BR8910
7	구매	153J/0805/0.1W/HANRYUK	EA	한룩전자(주)			1
12	E601802019-L	RES,CHIP	1.00000				BR8926
7	구매	183J/0805/0.1W/HANRYUK	EA	한룩전자(주)			1
13	E602202013-L	RES,CHIP	1.00000				BR8930
7	구매	223J/0805/0.1W/HANRYUK	EA	한룩전자(주)			1
14	E602402007-L	RES,CHIP	1.00000				BR8931
7	구매	243J/0805/0.1W/HANRYUK	EA	한룩전자(주)			1
15	E602703010-L	RES	3.00000				BR8913,16,20
7	구매	274J/0805/0.1W/HANRYUK	EA	한룩전자(주)			1
16	E603301012-L	RES,CHIP	1.00000				BR8925
7	구매	332J/0805/0.1W/HANRYUK	EA	한룩전자(주)			1
17	E603601006-L	RES,CHIP	1.00000				BR8928
7	구매	362J/0805/0.1W/HANRYUK	EA	한룩전자(주)			1
18	E603901017-L	RES,CHIP	2.00000				BR8911,29
7	구매	392J/0805/0.1W/HANRYUK	EA	한룩전자(주)			1
19	E603902015-L	RES	2.00000				BR8914,32
7	구매	393J/0805/0.1W/HANRYUK	EA	한룩전자(주)			1
20	E604700022-L	RES,CHIP	5.00000				BR8242,912,918,922,923
7	구매	471J/0805/0.1W/HANRYUK	EA	한룩전자(주)			1
21	E604701022-L	RES,CHIP	3.00000				BR8934,36,37
7	구매	472J/0805/0.1W/HANRYUK	EA	한룩전자(주)			1

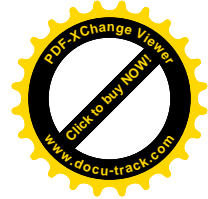
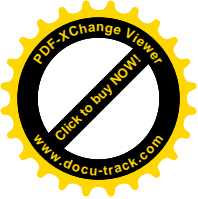

순번	자품목번호	품명	UOM	공정명	대체품 코드	대체품 품명	자재위치
Level	조달구분	규격	단위	제조사	대체품 규격	대체품 제조사	부품 PACKING 단위
22	E607501016-L	RES,CHIP	1.00000				BR8909
7	구매	752J/0805/0.1W/HANRYUK	EA	한룩전자(주)			1
23	E609101013-L	RES,CHIP	2.00000				BR8908,38
7	구매	912J/0805/0.1W/HANRYUK	EA	한룩전자(주)			1
24	E109005033-L	IC,SRAM	1.00000				BU8901
7	구매	ST72F324K2T6	EA	ST MICRO-ELECTRONICS			1
25	E101005309-L	IC	1.00000				BU8902
7	구매	NJM2370U05	EA	J.R.C			1
26	E302002934-L	DIODE/ZENER	1.00000				BZD8901
7	구매	MMSZ5235BT1G(6.8V)	EA	ON SEMI			1
					E302003282-L	DIODE/ZENER	
					MMSZ5235B	PAN JIT INTL INC(TW)	
27	E302002935-L	DIODE/ZENER	1.00000				BZD8902
7	구매	MMSZ5242BT1G(12V)	EA	ON SEMI			1
					E302003262-L	DIODE/ZENER	
					MMSZ5242B	DIODES INC.	
28	E8621196-L	CON	1.00000				CON8901
7	구매	53261-0690	EA	MOLEX			1
29	E308001259-L	DIODE/FRD	1.00000				BD8908
7	구매	05A4	EA	RECTRON			1
30	E75120394-L	PCB	1.00000				
7	구매	72*32*1.0t (PHV4 MICOM/Rev0.7)	EA	(주)다빈			1
					E75120393-L	PCB	
					72*32*1.0t (PHV4 MICOM/Rev0.7)	대진전자	
					E75120395-L	PCB	
					72*32*1.0t (PHV4 MICOM/Rev0.7)	현우산업(주)	
2	E86211201-L	CON	1.00000				CON8902
6	구매	PH01-24SRU	EA	PLASTRON			1
3	E8621194-L	CONNECTOR	2.00000				BJ8901,2
6	구매	PH01-02SSG	EA	PLASTRON			1

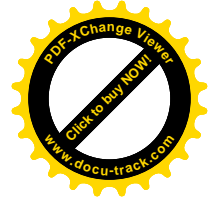
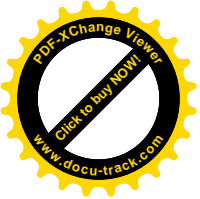

순번	자품목번호	품명	UOM	공정명	대체품 코드	대체품 품명	자재위치
Level	조달구분	규격	단위	제조사	대체품 규격	대체품 제조사	부품 PACKING 단위
2	D05PS4015681B	PDP	1.00000	E/T			
4	제작	PS-424-PH(101C)/PFC-PWM	EA				1
1	D05PS4015681B8	PDP	1.00000	ASY-3			
5	제작	PS-424-PH(101C)/PFC-PWM	EA				1
1	D05PS4015681B4	PDP	1.00000	ASY-1			
6	제작	PS-424-PH(101C)/PFC-PWM	EA				1
1	E401020013-L	CAPACITOR	3.00000				C8302,303,307
7	구매	102K/0805/X7R/50V/TKD	EA	TKD			1
2	E401030011-L	CAPACITOR	1.00000				C8320
7	구매	103K/0805/X7R/50V/TD	EA	TKD			1
3	E401040077-L	CAPACITOR	2.00000				C8304,309
7	구매	104K/0805/X7R/50V/TD	EA	TKD			1
4	E401050053-L	CAP.CHIP	2.00000				C8300,311
7	구매	105K/0805/X7R/25V/TD	EA	TKD			1
5	E402240032-L	CAP.CHIP	1.00000				C8305
7	구매	224K/0805/X7R/50V/TD	EA	TKD			1
6	E404740050-L	CAPACITOR	1.00000				C8310
7	구매	474K/0805/X7R/25V/TD	EA	TKD			1
7	E470100018-L	CAP, ELEC	1.00000				C8312
7	구매	RC 1.0uF/50V/105°C(4*5.3)	EA	삼화전기			1
8	E472200043-L	ELETROLYTIC CAP.	1.00000				C8301
7	구매	RC 22uF/25V/105°C(6.3*5.3)	EA	삼화전기			1
9	E101005282-L	IC	1.00000				U8300
7	구매	L4981AD	EA	ST MICRO-ELECTRONICS			1
10	E101000192-L	I.C	1.00000				U8301
7	구매	NJM2903M	EA	J.R.C			1
11	E101000795-L	I.C	1.00000				U8320
7	구매	TL431ASF	EA	(주)태진기술			1
12	E601501031-L	RES,CHIP	1.00000				R8305
7	구매	CRS152J/1206/0.25W	EA	한록전자(주)			1

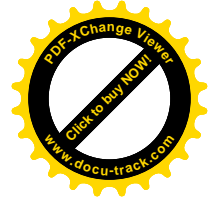
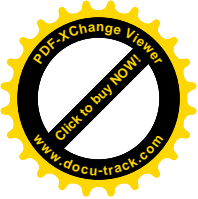

순번	자품목번호	품명	UOM	공정명	대체품 코드	대체품 품명	자재위치
Level	조달구분	규격	단위	제조사	대체품 규격	대체품 제조사	부품 PACKING 단위
13	E601001180-L	RES,CHIP	1.00000				R8321
7	구매	CRS103J/1206/0.25W	EA	한룩전자(주)			1
14	E602002027-L	RES,CHIP	2.00000				R8322,323
7	구매	CRS203F/1206/0.25W	EA	한룩전자(주)			1
15	E602202017-L	RES,CHIP	1.00000				R8308
7	구매	CRS223F/1206/0.25W	EA	한룩전자(주)			1
16	E602203008-L	RES,CHIP	2.00000				R8304,8324
7	구매	CRS224F/1206/0.25W	EA	한룩전자(주)			1
17	E602702021-L	RES,CHIP	1.00000				R8302
7	구매	CRS273F/1206/0.25W	EA	한룩전자(주)			1
18	E605101017-L	RES	1.00000				R8303
7	구매	CRS512F/1206/0.25W	EA	한룩전자(주)			1
19	E608203010-L	RES	1.00000				R8320
7	구매	CRS824J/1206/0.25W	EA	한룩전자(주)			1
20	E609101014-L	RES,CHIP	2.00000				R8300,01
7	구매	CRS912F/1206/0.25W	EA	한룩전자(주)			1
21	E609102011-L	RES,CHIP	1.00000				R8307
7	구매	CRS913F/1206/0.25W	EA	한룩전자(주)			1
22	E603302023-L	RES,CHIP	1.00000				R8325
7	구매	CRS333F/1206/0.25W	EA	한룩전자(주)			1
23	E75120385-L	PCB	1.00000				
7	구매	40.5*30*1.0t (PHV4 PFC/Rev0.7)	EA	(주)다빈			1
					E75120384-L	PCB	
					40.5*30*1.0t (PHV4 PFC/Rev0.7)	대진전자	
					E75120386-L	PCB	
					40.5*30*1.0t (PHV4 PFC/Rev0.7)	현우산업(주)	
2	E86210247-L	CON	1.00000				CN8008
6	구매	PH01-16-SRU	EA	PLASTRON			1
3	D05PS4015681C	PDP	1.00000	E/T			
4	제작	PS-424-PH(101C)/VS-PWM	EA				1

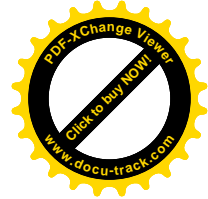
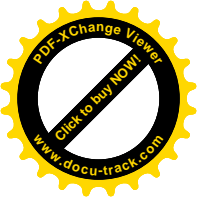

순번	자품목번호	품명	UOM	공정명	대체품 코드	대체품 품명	자재위치
Level	조달구분	규격	단위	제조사	대체품 규격	대체품 제조사	부품 PACKING 단위
1	D05PS4015681C8	PDP	1.00000	ASY-3			
5	제작	PS-424-PH(101C)/VS-PWM	EA				1
1	D05PS4015681C4	PDP	1.00000	ASY-1			
6	제작	PS-424-PH(101C)/VS-PWM	EA				1
1	E401030011-L	CAPACITOR	5.00000				C8207,212,219,220,221
7	구매	103K/0805/X7R/50V/TD	EA	TDK			1
2	E401040077-L	CAPACITOR	2.00000				C8205,208
7	구매	104K/0805/X7R/50V/TD	EA	TDK			1
3	E401050053-L	CAP.CHIP	4.00000				C8129,206,209,214
7	구매	105K/0805/X7R/25V/TD	EA	TDK			1
4	E402020001-L	CAPACITOR	1.00000				C8218
7	구매	202K/0805/X7R/50V/AV	EA	AVX			1
5	E402210012-L	CAPACITOR	2.00000				C8213,217
7	구매	221J/0805/NPO/50V/TD	EA	TDK			1
6	E471000062-L	CAP,ELEC	1.00000				C8211
7	구매	RC 10uF/50V/105℃(6.3*5.3)	EA	삼화전기			1
7	E102000682-L	IC	1.00000				IC8200
7	구매	MC14093BD	EA	ON SEMI			1
8	E101002103-L	IC	1.00000				IC8201
7	구매	TL494CDR	EA	T.I			1
9	E201000832-L	T.R	1.00000				Q8204
7	구매	KTN2222AS	EA	KEC			1
10	E600000016-L	RES,CHIP	2.00000				R8281,282
7	구매	CRS0R0J/1206/0.25W	EA	한룩전자(주)			1
11	E601000108-L	RES,CHIP	1.00000				R8255
7	구매	CRS101J/1206/0.25W	EA	한룩전자(주)			1
12	E601001179-L	RES,CHIP	2.00000				R8235,243
7	구매	CRS102J/1206/0.25W	EA	한룩전자(주)			1
13	E601001180-L	RES,CHIP	1.00000				R8250
7	구매	CRS103J/1206/0.25W	EA	한룩전자(주)			1

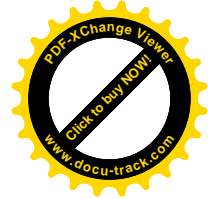
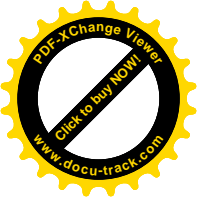

순번	자품목번호	품명	UOM	공정명	대체품 코드	대체품 품명	자재위치
Level	조달구분	규격	단위	제조사	대체품 규격	대체품 제조사	부품 PACKING 단위
14	E601203014-L	RES	2.00000				R8248,280
7	구매	CRS124J/1206/0.25W	EA	한룩전자(주)			1
15	E601501031-L	RES,CHIP	1.00000				R8246
7	구매	CRS152J/1206/0.25W	EA	한룩전자(주)			1
16	E601502029-L	RES,CHIP	1.00000				R8258
7	구매	CRS153J/1206/0.25W	EA	한룩전자(주)			1
17	E602201025-L	RES,CHIP	1.00000				R8249
7	구매	CRS222J/1206/0.25W	EA	한룩전자(주)			1
18	E602401014-L	RES	1.00000				R8245
7	구매	CRS242J/1206/0.25W	EA	한룩전자(주)			1
19	E603001019-L	RES,CHIP	1.00000				R8239
7	구매	CRS302J/1206/0.25W	EA	한룩전자(주)			1
20	E603301018-L	RES,CHIP	1.00000				R8279
7	구매	CRS332J/1206/0.25W	EA	한룩전자(주)			1
21	E603302023-L	RES,CHIP	1.00000				R8251
7	구매	CRS333F/1206/0.25W	EA	한룩전자(주)			1
22	E603903010-L	RES	1.00000				R8256
7	구매	CRS394J/1206/0.25W	EA	한룩전자(주)			1
23	E604702026-L	RES,CHIP	2.00000				R8247,257
7	구매	CRS473J/1206/0.25W	EA	한룩전자(주)			1
24	E608201017-L	RES	1.00000				R8252
7	구매	CRS822J/1206/0.25W	EA	한룩전자(주)			1
25	E75120379-L	PCB	1.00000				
7	구매	39*34.5*1.0t (PHV4 VS/Rev0.65)	EA	다빈전자			1
					E75120378-L	PCB	
					39*34.5*1.0t (PHV4 VS/Rev0.65)	대진전자	
					E75120380-L	PCB	
					39*34.5*1.0t (PHV4 VS/Rev0.65)	현우산업(주)	
2	E8621202-L	PIN CONNECTOR	1.00000				CN8333
6	구매	PH01-11SRU	EA	PLASTRON			1

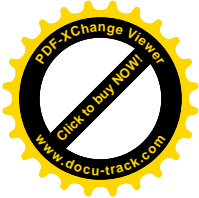
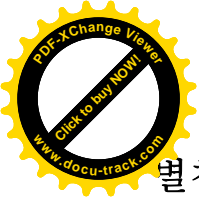

별첨2

NO	PART NAME	Q'TY	MATERIAL	PRODUCT SIZE	FINISH
1	HEAT SINK	1	A6063S-T5	131*35*32	WHITE ANODIZING
2	단자	2	SPC		Sn-PLT

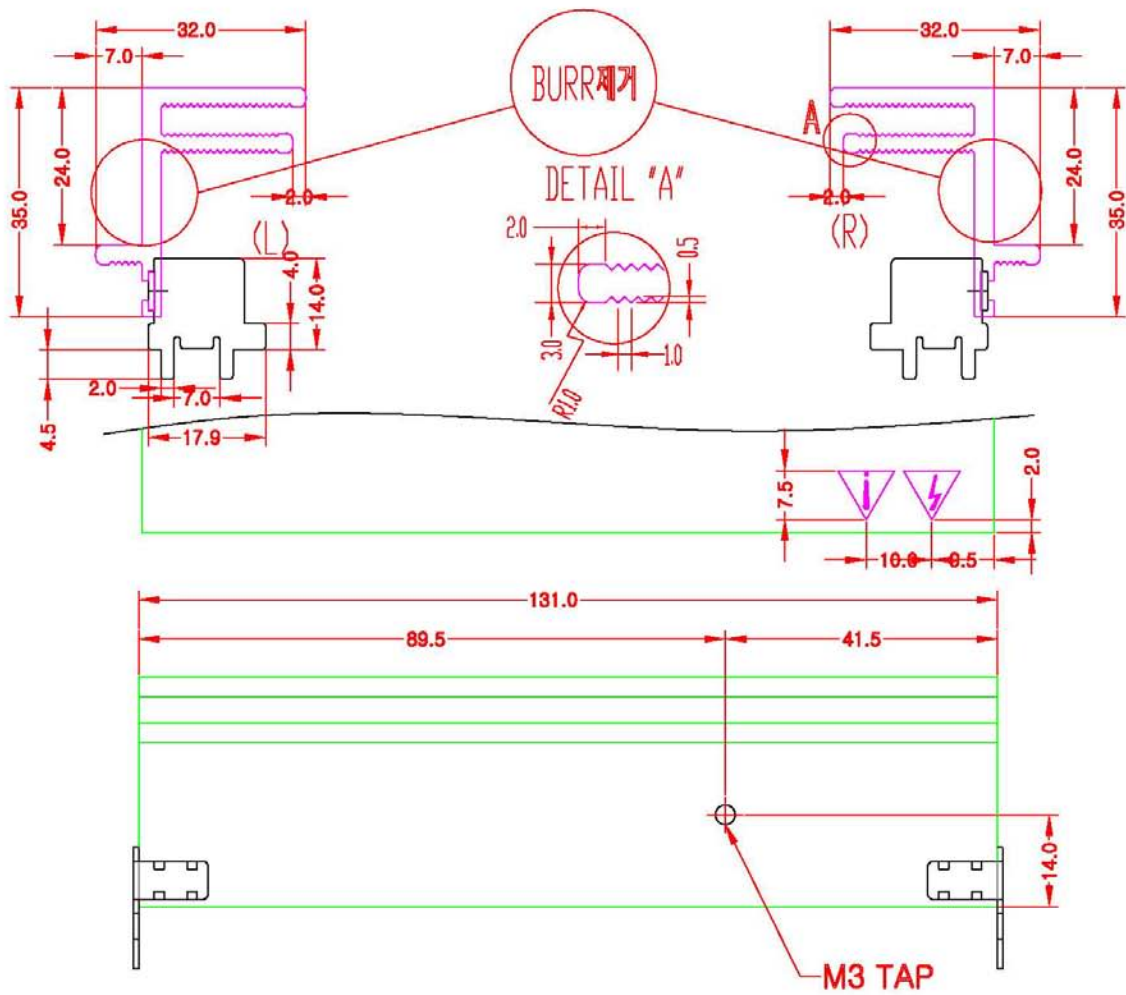

DATE	REVISION RECORD			WRITTEN BY		CHECKED BY	REMARKS
TOLERANCE	SCALE	DRAW	DESIGED	CHECKED	APPROVED	PART NAME	HEAT SINK
±0.3	1/1	C,W,K			'05.06.09	MODEL	H8001
MI KYEONG SCREEN CO.,LTD						E-CODE	E703203210-L



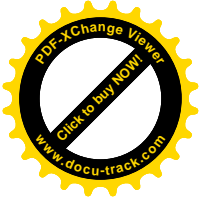
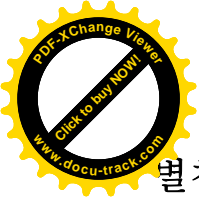

별첨2

NO	PART NAME	Q'TY	MATERIAL	PRODUCT SIZE	FINISH
1	HEAT SINK	1	A6063S-T5	156.1*35*32	WHITE ANODIZING
2	단자	2	SPC		Sn-PLT

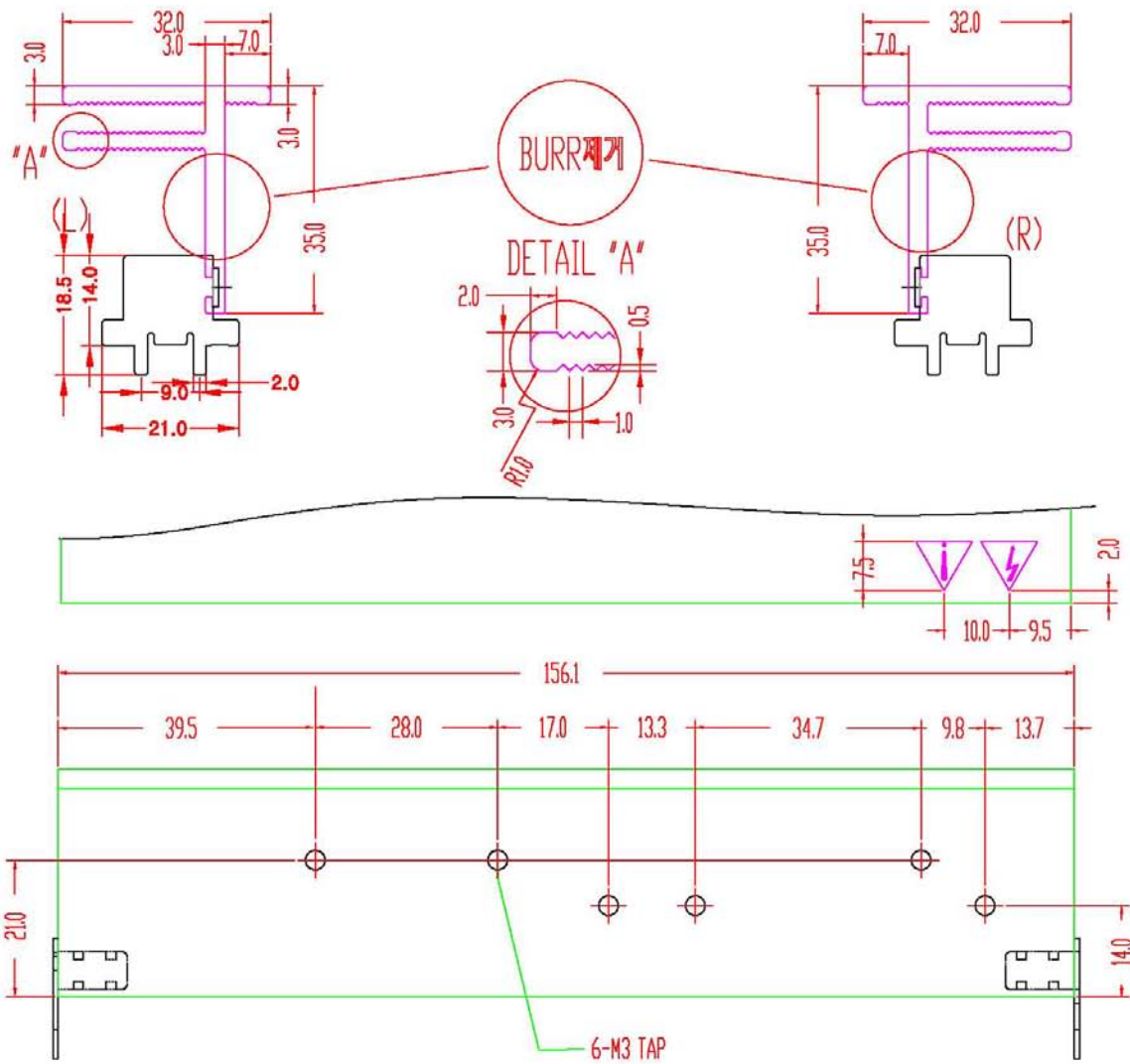

DATE	REVISION RECORD			WRITTEN BY		CHECKED BY	REMARKS
TOLERANCE	SCALE	DRAW	DESIGD	CHECKED	APPROVED	PART NAME	HEAT SINK
±0.3		C,W,K			'05.03.28	MODEL	H8002
MI KYEONG SCREEN CO.,LTD						E-CODE	E703202900-L

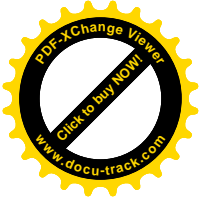
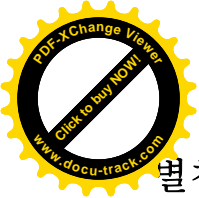

별첨2

NO	PART NAME	Q'TY	MATERIAL	PRODUCT SIZE	FINISH
1	HEAT SINK	1	A6063S-T5	61*35*32	WHITE ANODIZING
2	단자	2	SPC		Sn-PLT

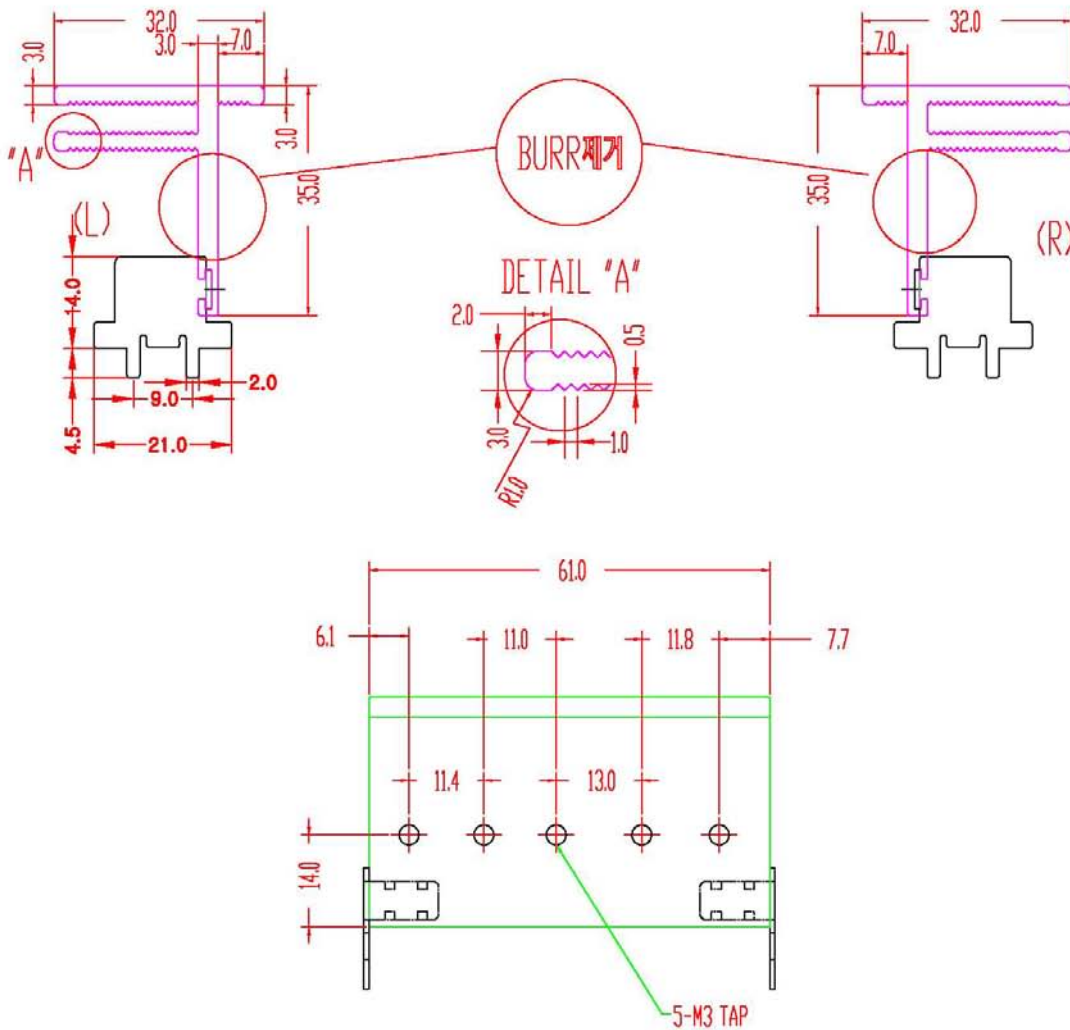

DATE	REVISION RECORD			WRITTEN BY		CHECKED BY	REMARKS
TOLERANCE	SCALE	DRAW	DESIGD	CHECKED	APPROVED	PART NAME	HEAT SINK
±0.3	/	C,W,K			'05.03.28	MODEL	H8004
MI KYEONG SCREEN CO.,LTD						E-CODE	E703202930-L

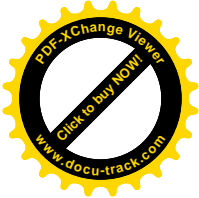
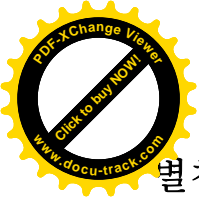

별첨2

NO	PART NAME	Q'TY	MATERIAL	PRODUCT SIZE	FINISH
1	HEAT SINK	1	A6063S-T5	116*35*32	WHITE ANODIZING
2	단자	2	SPC		Sn-PLT

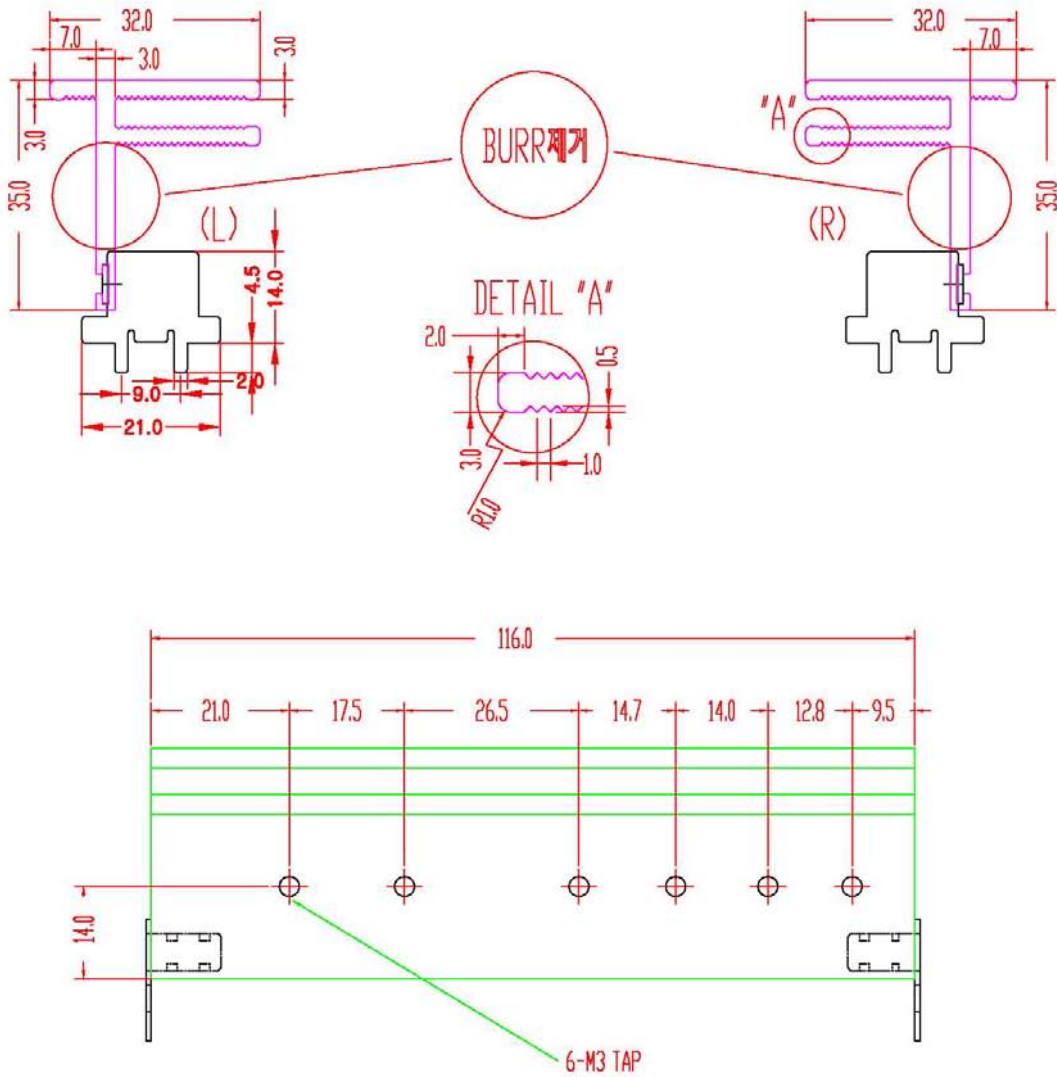

DATE	REVISION RECORD			WRITTEN BY		CHECKED BY	REMARKS
TOLERANCE	SCALE	DRAW	DESIGED	CHECKED	APPROVED	PART NAME	HEAT SINK
±0.3		C,W,K			'05.03.28	MODEL	H8005
MI KYEONG SCREEN CO.,LTD						E-CODE	E703202960-L

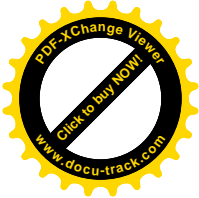
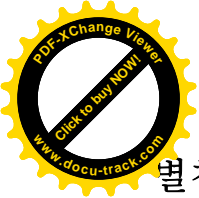

별첨2

NO	PART NAME	Q'TY	MATERIAL	PRODUCT SIZE	FINISH
1	HEAT SINK	1	A6063S-T5	91*35*32	WHITE ANODIZING
2	단자	2	SPC		Sn-PLT

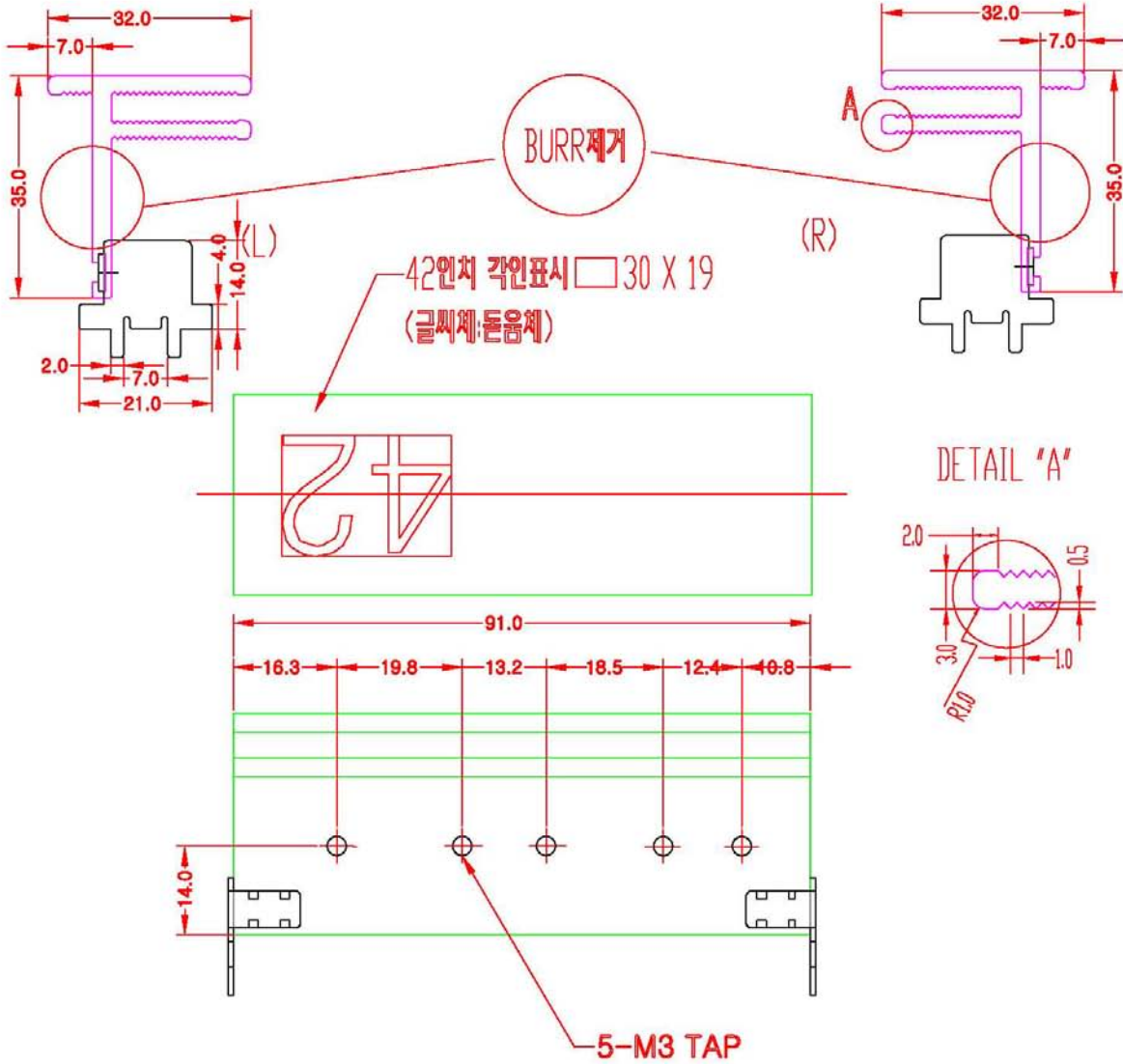

DATE	REVISION RECORD			WRITTEN BY		CHECKED BY	REMARKS
TOLERANCE	SCALE	DRAW	DESIGED	CHECKED	APPROVED	PART NAME	HEAT SINK
±0.3	2/1	C,W,K			'05.06.09	MODEL	H8006
MI KYEONG SCREEN CO.,LTD						E-CODE	E703202990-L

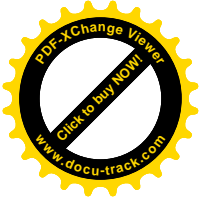
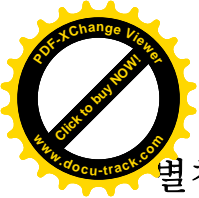

별첨2

NO	PART NAME	Q'TY	MATERIAL	PRODUCT SIZE	FINISH
1	HEAT SINK	1	A6063S-T5	156*35*32	WHITE ANODIZING
2	단자	2	SPC		Sn-PLT

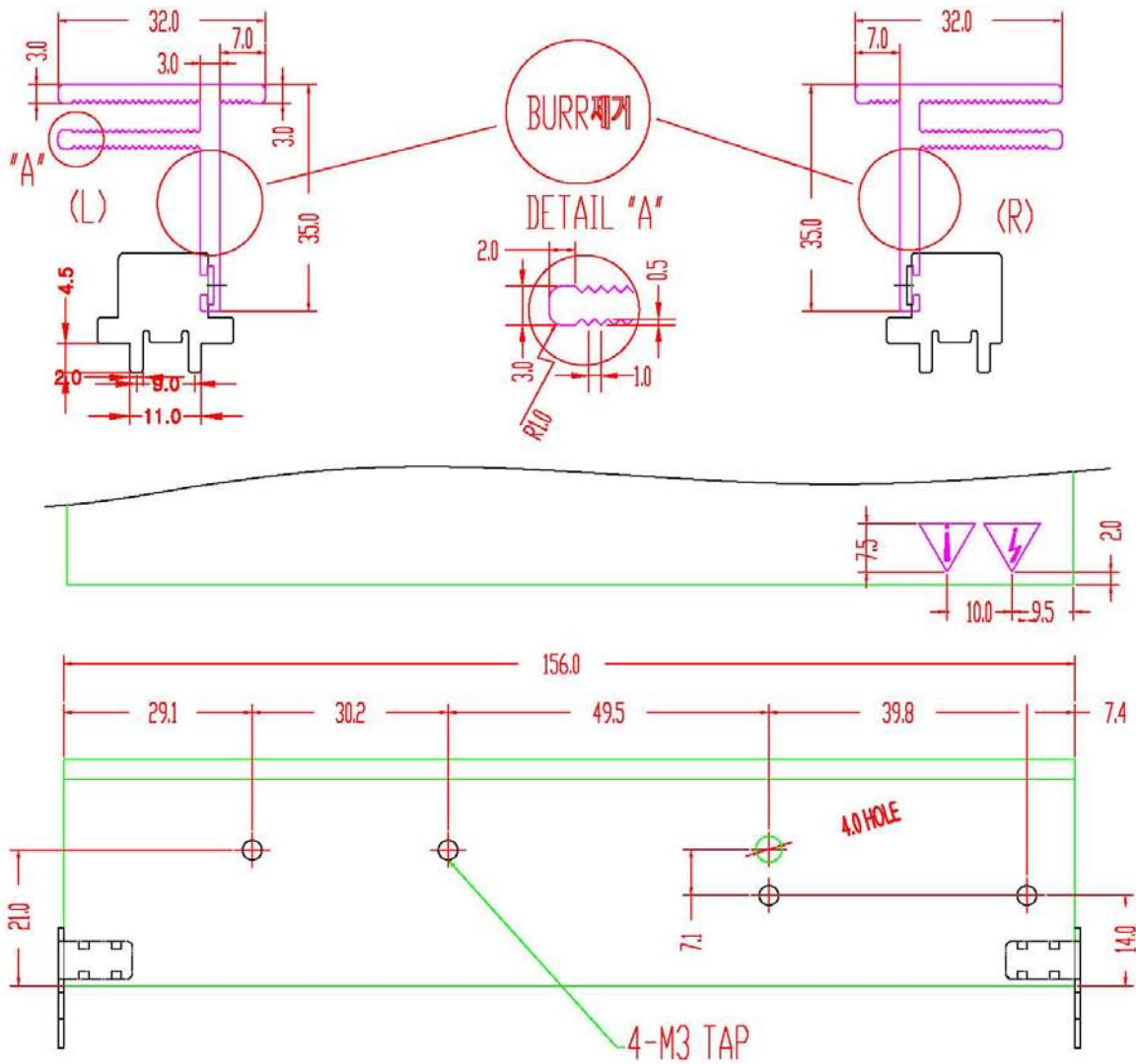

DATE	REVISION RECORD			WRITTEN BY		CHECKED BY	REMARKS
TOLERANCE	SCALE	DRAW	DESIGED	CHECKED	APPROVED	PART NAME	HEAT SINK
±0.3		C,W,K			'05.03.28	MODEL	H8007
MI KYEONG SCREEN CO.,LTD						E-CODE	E703203020-L

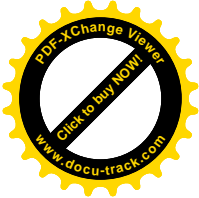
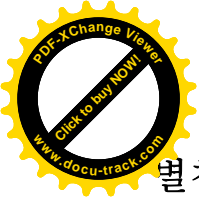

별첨2

NO	PART NAME	Q'TY	MATERIAL	PRODUCT SIZE	FINISH
1	HEAT SINK	1	A6063S-T5	30*15*11	초음파 탈지
2	SOLDER PIN	1	C2602 1/2H		Sn-PLT

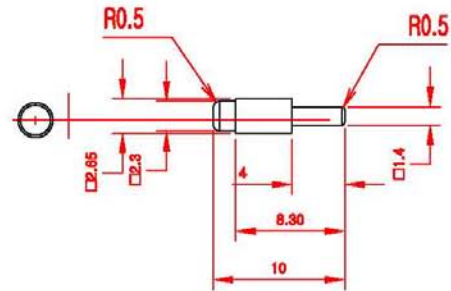
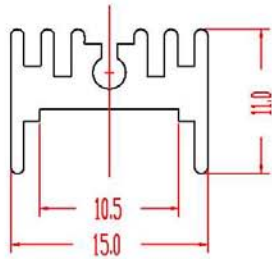

SOLDER PIN

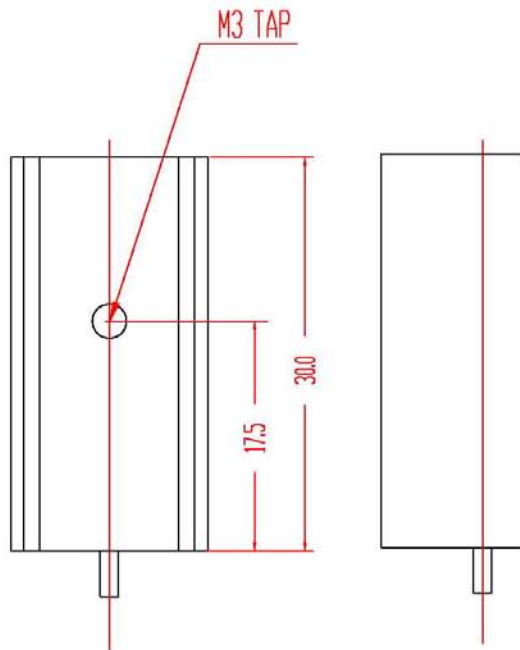

NOTE

1. SOLDER PIN 압입후 흔들림이 없을것.
2. TAP 가공상태가 양호할것.

DATE	REVISION RECORD			WRITTEN BY		CHECKED BY	REMARKS
TOLERANCE	SCALE	DRAW	DESIGED	CHECKED	APPROVED	PART NAME	HEAT SINK
±0.3	2/1	C,W,K			'05.03.28	MODEL	H8009,10,11
MI KYEONG SCREEN CO.,LTD						E-CODE	E703203050-L

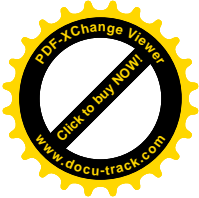
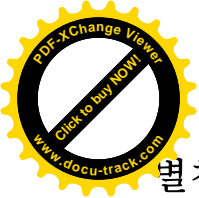

별첨2

NO	PART NAME	Q'TY	MATERIAL	PRODUCT SIZE	FINISH
1	HEAT SINK	1	A6063S-T5	30*15*11	초음파 탈지
2	SOLDER PIN	2	C2602 1/2H		Sn-PLT

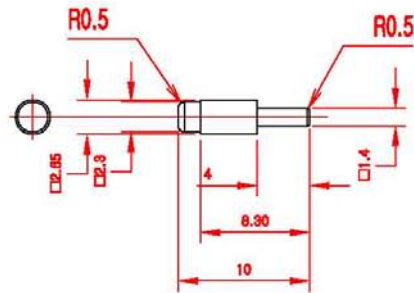
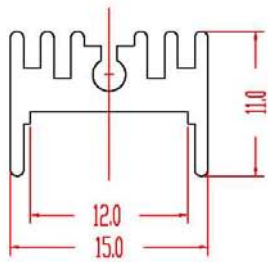

SOLDER PIN S:2/1

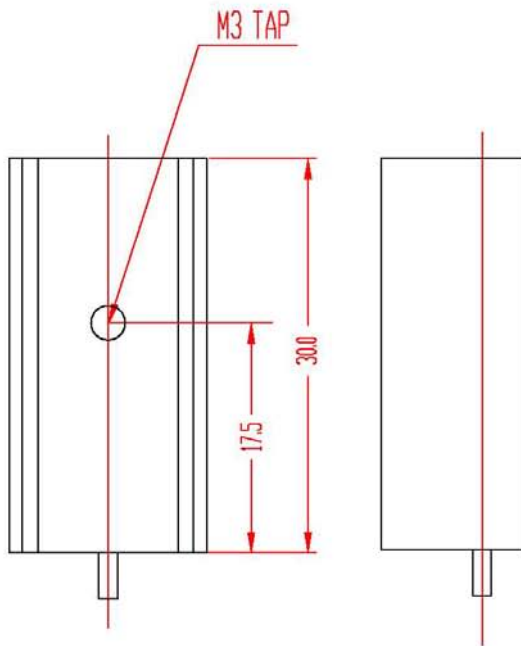

- NOTE**
1. SOLDER PIN 압입후 흔들림이 없을것.
  2. TAP 가공상태가 양호할것.

DATE		REVISION RECORD		WRITTEN BY		CHECKED BY		REMARKS
TOLERANCE	SCALE	DRAW	DESIGED	CHECKED	APPROVED	PART NAME	HEAT SINK	
±0.3	2/1	C,W,K			'05.06.09	MODEL	H8012	
MI KYEONG SCREEN CO.,LTD						E-CODE	E703203080-L	

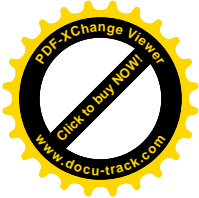
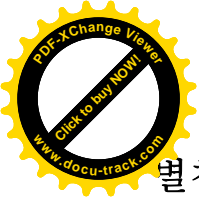

별첨2

NO	PART NAME	Q'TY	MATERIAL	PRODUCT SIZE	FINISH
1	CLAMP-1	1	A6063S-T5	87.5*16.3*7	초음파 탈지

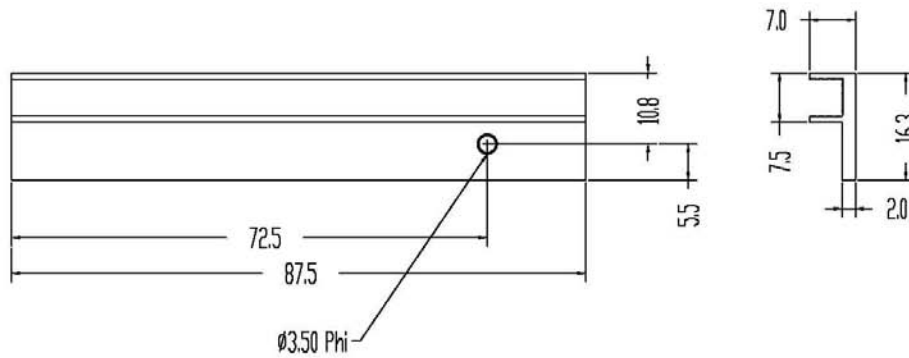

DATE	REVISION RECORD			WRITTEN BY		CHECKED BY	REMARKS
TOLERANCE	SCALE	DRAW	DESIGED	CHECKED	APPROVED	PART NAME	HEAT SINK
±0.3		C,W,K			'05.03.28	MODEL	CLAMP-1
MI KYEONG SCREEN CO.,LTD						E-CODE	E90908165-L



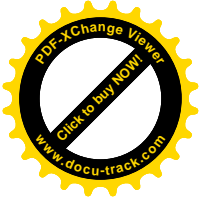
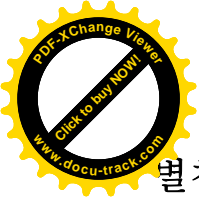

별첨2

NO	PART NAME	Q'TY	MATERIAL	PRODUCT SIZE	FINISH
1	CLAMP	1	A1050P 1/2H	2.0t*22*8	WHITE ALUMITE
2					

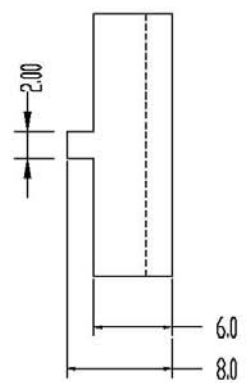
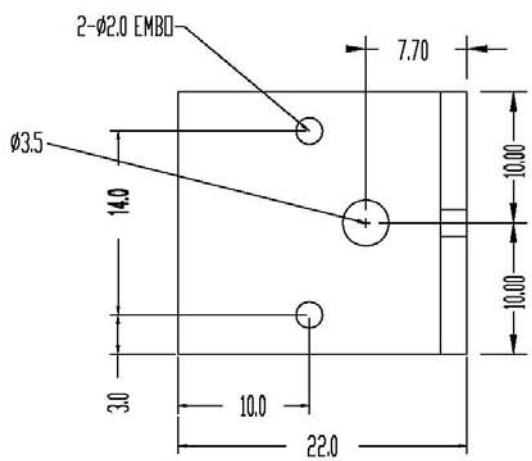
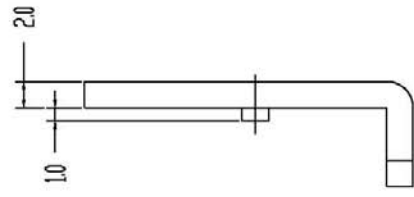

DATE		REVISION RECORD		WRITTEN BY		CHECKED BY		REMARKS	
TOLERANCE	SCALE	DRAW	DESIGED	CHECKED	APPROVED	PART NAME	HEATSINK		
±0.3		C,W.K			'05.03.28	MODEL	CLAMP		
MI KYEONG SCREEN CO.,LTD						E-CODE	E90908169-L		

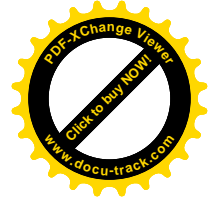
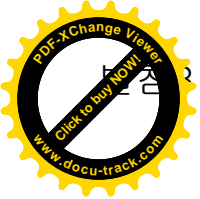

[PH-V4 LJ44-00101C ECO Change item]

Block	Location	Rev0.65 Component	ECO (42") Component	PCB	Change History
AC	L8005,8006	CV108200S	DV505140BS(φ 25)	No Change	Low cost Component Development
	D8006	RS3506M	RS1505M		
	C8003	X2 275VAC 474M	LE474		
	C8004,8005	X2 275VAC 105M	LE105		
	SA8001	V20E 420	20S681K		
	RA8001,8002	DSP-501-N	TSA-501M		
	R8109,10,11	68K/1W	75K/1W	No Change	Power consumption solution
	D8022	-	UF4007(Add)	Change	
	Detect Point	D8014	D8015	Change	
	D8001	ON_semi	VISHAY	No Change	Change Vender For Temperature Stress take Margin
R8012	Micron	Smart	No Change		

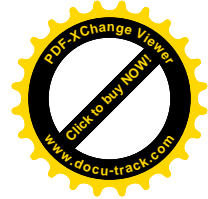
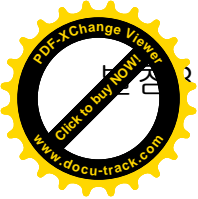

[PH-V4 LJ44-00101C ECO Change item]

Block	Location	Rev0.65 Component	ECO (42") Component	PCB	Change History
Standby	H8008	Existence	Remove	No Change	<b>Low cost Component Development</b>
	D8016, D8018	D1FL20U	UF4007	Change	<b>Power consumption solution</b>
	R8095	2.2/1W	1.5/1W	No Change	
	Q8008	2SK3532-01MR FUJI	STP6NK90ZFP ST	No Change	
	R8054, R8056	-	10K*2 (Add)	Change	<b>Add TR Switching, Circuit For " ADJ control"</b>
	Q8002	-	KTN2222AS (Add)		
	R8096 R8101 R8106 IC8008 U8002 R8076 C8021	10K 2.2K 4.7K TECT1103 ST-22 10K 50V/104	Remove	Change	<b>Remove ' Thermal Detect" For Power consumption solution</b>
	ZD8100 ZD8225	MMSZ5254 MMSZ5227	1N4750 1N747A	Change	<b>P/L Test solution</b>

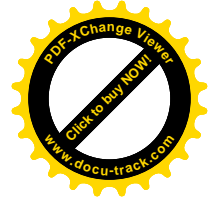
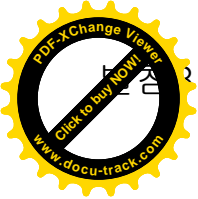

[PH-V4 LJ44-00101C ECO Change item]

Block	Location	Rev0.65 Component	ECO (42") Component	PCB	Change History
PFC	C8007,8010	HP 450V 330uF	HP 450V 220uF	No Change	Low cost Component Development
	D8021	-	SB140 (Add)	Change	Gate circuit Change For Temperature Stress take Margin
	R8021, R8260	10K	15K	No Change	
	ZD8220	-	1N4746 (Add)	Change	
	R8301~12, R8319,20 R8022	20(SMD)*12 - -	68(SMD)*14 220(Add)	Change	
	C8012 R8002	103/1K 4.7/3W	104/630V 220K/3W	Change	Voltage Stress Improvement which Follow In Temperature Stress take Margin
	IC8007 C8001	KIA7818 250V/104	KIA7815 630V/104	No Change	PFC Temperature Stress take Margin
	R8037	1K	330	No Change	PFC Current Stress take Margin
	R8022 Q8002 C8220 ZD8220 ZD8221 IC8220 C8227 R8290	1K KTC3205 104/50V 1N4747 1N4747 KIA7815 100uF/35V 0	Remove	Change	Gate circuit Change For Temperature Stress take Margin

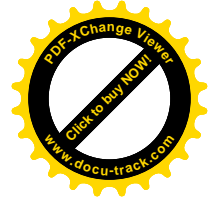
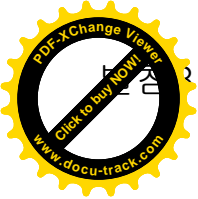

[PH-V4 LJ44-00101C ECO Change item]

Block	Location	Rev0.65 Component	ECO (42") Component	PCB	Change History
PFC	C8243 R8317 R8318	-	1KV/103 (Add) 47K (Add) 47K (Add)	Change	<b>Voltage Stress Improvement which Follow In Temperature Stress take Margin</b>
	R8007	-	3.3 (Add)	No Change	
PFC SUB	R8324 R8325	-	220K (Add) 33K (Add)	Change	<b>IC UVLO Level Adjustment</b>
VA	C8112	50V/103	100V/103	No Change	<b>Cap crack Solution</b>
	C8105, C8108 C8231	KM 100V 680uF	KM 100V 470uF	No Change	
	R8226, R8230	JRW1N 0R54J	1W 0.54J	No Change	
VG	IC8026	LM2576V-ADJG	LM2576V-ADJG	No Change	<b>Low cost Component Development</b>
VS	Q8020, Q8022	FQA24N60	IXTQ22N60P	No Change	
	C8098, C8099	HP 315V 680uF	HP 315V 470uF	No Change	
VCC	IC8014	LM2576V-5G	LM2576V-5G	No Change	<b>F/B Value Change For No load Characteristic take Margin</b>
	IC8041	LM2576V-ADJG	LM2576V-ADJG	No Change	
	R8160 R8165 R8264	18K 3K 200K	3K 1K 1K	No Change	

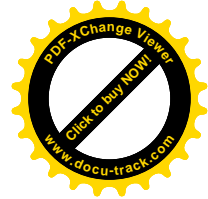
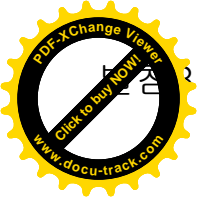

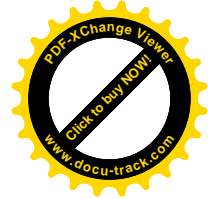
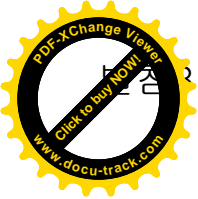

[PH-V4 LJ44-00101C ECO Change item]

Block	Location	Rev0.65 Component	ECO (42") Component	PCB	Change History
Vsemi	IC8013	LM2576V-5G	LM2576V-5G	No Change	Low cost Component Development
Vset	R8150	JRW1N1R0J	1W 1J		
Ve	R8189	JRW1N0R5J	1W 0.5J		
Vscan	R8232	JRW1N1R5J	1W 1.5J	Chang	Not use
	D8057	D1FL20U	Remove		
	R8173	240K/3W	56K/3W	No Change	Stress take Margin
	R8283	39K/2W	56K/3W		
R8284	39K/2W	56K/3W			
Sequence	IC8001,IC8005, IC8009,IC8010	TECT1103	TECT1109	No Change	Characteristic Improvement In High Temperature
	IC8004,18,20, 22,25,30,31, 32,37,8300	TECT1103	LTV817BN	No Change	Low cost Component Development

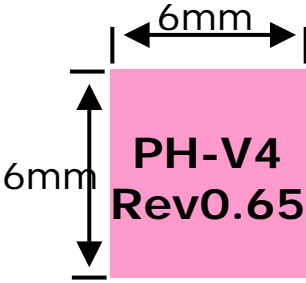
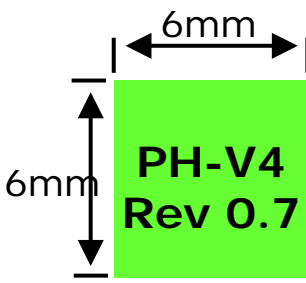

[PH-V4 LJ44-00101C ECO Change item]

Block	Location	Rev0.65	ECO (42")	PCB	Reference
Microm	BD8908	—	05A4 (400V0.5A)	Change	Noise DC_Prot
	Sticker Color			No Change	Revision Distinguish Due to add diode(05A4) Within Alarm b'd
Pattern	AC Line	—	After 2'nd Line Filter (L8006)Movement	Change	POD Noise Improvement
	Heat sink	—	All Heat Sink PCB PAD Strengthen	Change	Work Improvement
	C8002,C8011 C8013			Change	Work Improvement

- No Wattage Mark Resistor is 1206 type SMD Resistor. Refer to Append each change Item & Remove Item

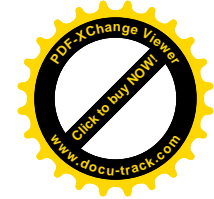
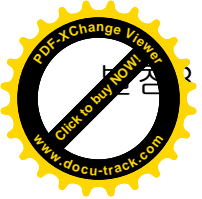

### [PH-V4 LJ44-00101C ECO Change item]

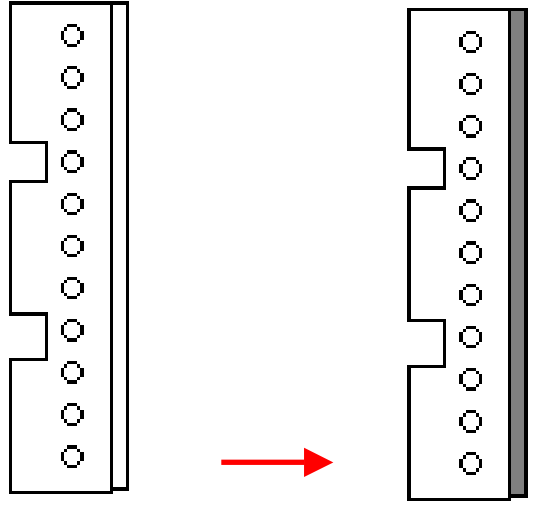
	ITEM	내역	
1	Connector Silk	 <p data-bbox="869 917 1041 949">&lt;Rev 0.65&gt;</p> <p data-bbox="1198 917 1433 949">&lt;Rev 0.7 ECO&gt;</p>	Add silk Line.



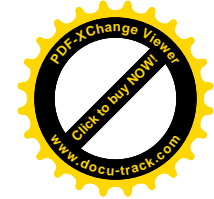
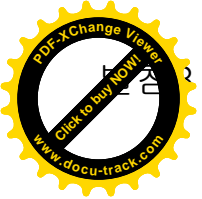

### [PH-V4 LJ44-00101C ECO Change item]

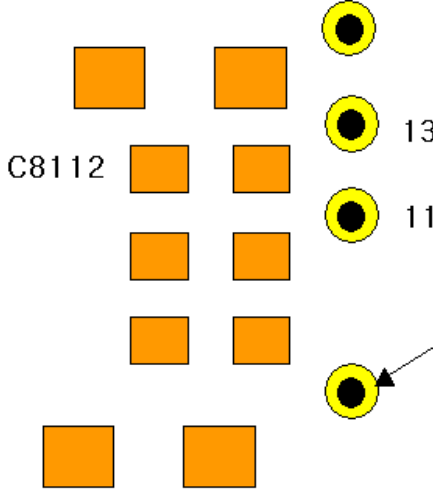
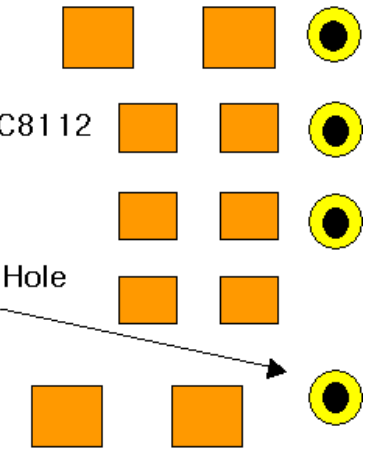
	ITEM	내용	
2	Va Component	 <p data-bbox="981 906 1146 938">&lt;Rev 0.65&gt;</p>	 <p data-bbox="1563 906 1774 938">&lt;Rev 0.7ECO&gt;</p>
3	All Bottom Silk	Adding Silk for Clinch short Prevention	

[PH-V4 LJ44-00101C ECO Add Change item]

Block	Location	Rev0.65 Component	ECO (42") Component	Change History
VS	C8202,8203	105/63V (Box) Pitch : 5mm	105/100V(Dipping) Pitch : 7.5mm	Component Reliability take Margin

1. PCB Top Side

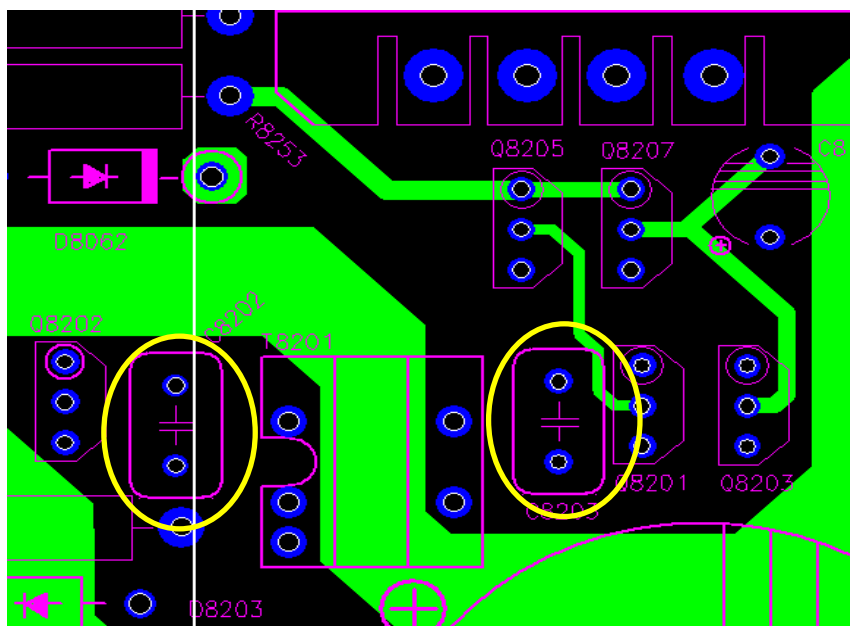

(As is)

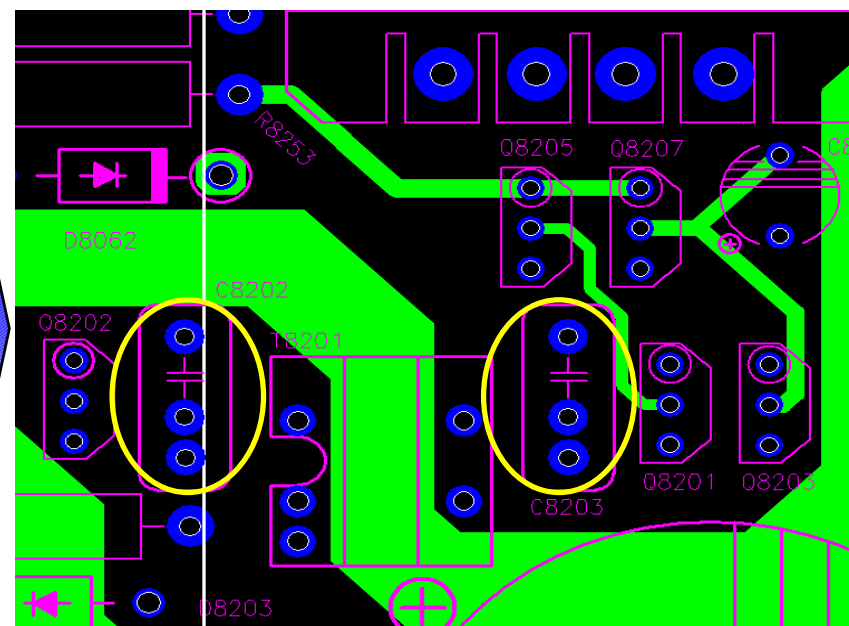

(To be)

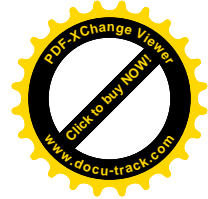
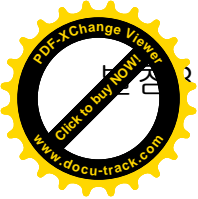

### [PH-V4 LJ44-00101C ECO Add Change item]

Block	Location	Rev0.65 Component	ECO (42") Component	Change History
VS	C8202,8203	105/63V (Box) Pitch : 5mm	105/100V(Dipping) Pitch : 7.5mm	Component Reliability take Margin

### 2. PCB Bottom Side

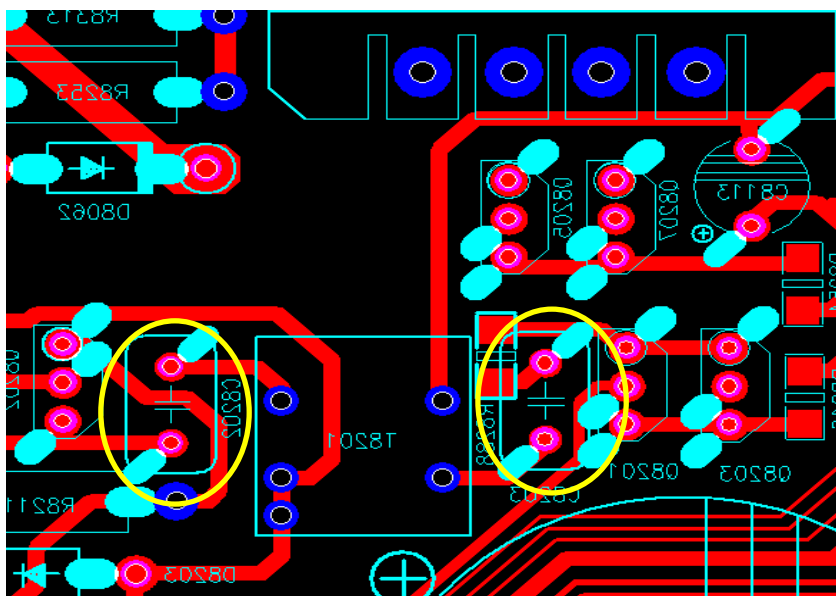

(As is)

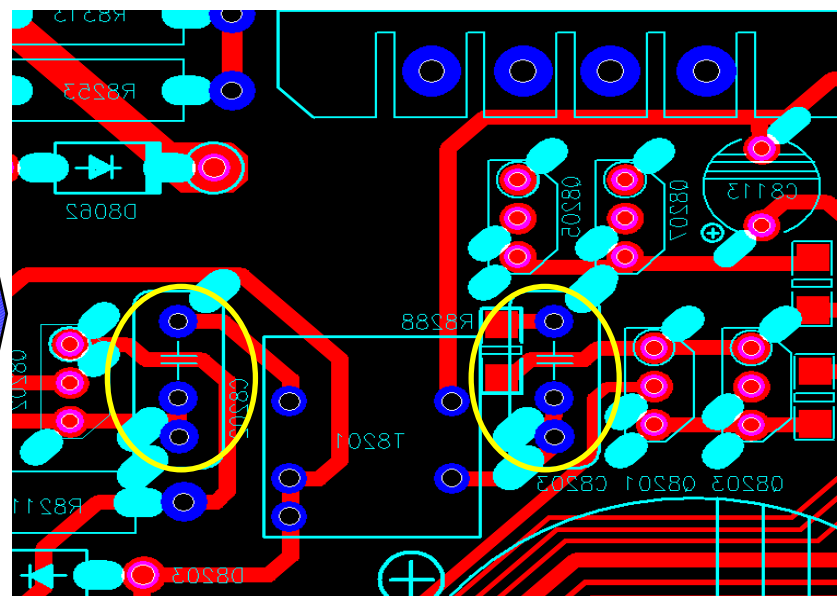
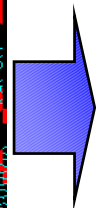

(To be)

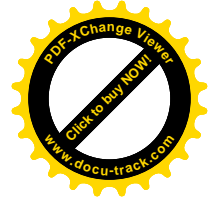
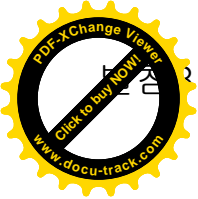

[PH-V4 LJ44-00101C ECO Add Change item]

Block	Location	Rev0.65 Component	ECO (42") Component	Change History
VS	C8202,8203	105/63V (Box)	105/100V(Dipping)	Component Reliability take Margin
	T8201	EE1312(No Barrier)	EE1312 (Barrier)	
Vsemi	R8120	3W 750J	3W 1.8KJ	Customer V.O.C

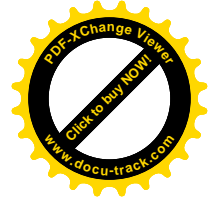
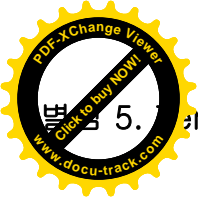

별첨 5. Zener Diode 제조사 추가

No.	규격	제조사	대체품 규격	대체품 제조사	자재위치
1	MMSZ5227BT1G(3.6V)	ON SEMI			ZD8226,ZD8227,ZD8228,ZD8229,ZD8230,ZD8231,ZD8233,ZD8235
			MMSZ5227B	PAN JIT INTL INC.(TW)	
2	MMSZ5231BT1G(5.1V)	ON SEMI			ZD8003
			MMSZ5231B	DIODES INC.	
3	MMSZ5235BT1G(6.8V)	ON SEMI			ZD8223
			MMSZ5235B	PAN JIT INTL INC.(TW)	
4	MMSZ5241BT1G(11V)	ON SEMI			ZD8101,ZD8102
			MMSZ5241B	PAN JIT INTL INC.(TW)	
5	MMSZ5245BT1G(15V)	ON SEMI			ZD8004,ZD8005,ZD8205
			MMSZ5245B	DIODES INC.	
6	MMSZ5254BT1G(27V)	ON SEMI			ZD8222
			MMSZ5254B	PAN JIT INTL INC.(TW)	
7	MMSZ5235BT1G(6.8V)	ON SEMI			BZD8901
			MMSZ5235B	PAN JIT INTL INC.(TW)	
8	MMSZ5242BT1G(12V)	ON SEMI			BZD8902
			MMSZ5242B	DIODES INC.	