

- Tentative Specification
- Preliminary Specification
- Approval Specification

MODEL NO.: V390HJ1

SUFFIX: PE1

39" FHD\_60Hz\_Open Cell

Customer:	
APPROVED BY	SIGNATURE
Name / Title _____	_____
Note	
_____	
Please return 1 copy for your confirmation with your signature and comments.	

Approved By	Checked By	Prepared By
Chao-Chun Chung	Vita Wu	WJ Chang

CONTENTS

CONTENTS.....	2
REVISION HISTORY.....	4
1. GENERAL DESCRIPTION .....	5
1.1 OVERVIEW .....	5
1.2 FEATURES .....	5
1.3 MECHANICAL SPECIFICATIONS.....	6
2. ABSOLUTE MAXIMUM RATINGS .....	7
2.1 ABSOLUTE RATINGS OF ENVIRONMENT.....	7
2.2 ABSOLUTE RATINGS OF ENVIRONMENT (OPEN CELL).....	8
2.3 ELECTRICAL ABSOLUTE RATINGS.....	8
2.3.1 TFT LCD MODULE.....	8
3. ELECTRICAL CHARACTERISTICS.....	9
3.1 TFT LCD OPEN CELL .....	9
4. INPUT TERMINAL PIN ASSIGNMENT .....	10
4.1 TFT LCD OPEN CELL .....	11
5. INPUT TERMINAL PIN ASSIGNMENT .....	12
5.1 TFT LCD OPEN CELL INPUT.....	12
5.2 COLOR DATA INPUT ASSIGNMENT.....	15
5.3 FLICKER (Vcom) ADJUSTMENT .....	17
6. INTERFACE TIMING.....	18
6.1 INPUT SIGNAL TIMING SPECIFICATIONS .....	18
6.2 POWER ON/OFF SEQUENCE .....	20
7. OPTICAL CHARACTERISTICS.....	21
7.1 TEST CONDITIONS.....	21
7.2 OPTICAL SPECIFICATIONS .....	22
8. PRECAUTIONS.....	22
8.1 ASSEMBLY AND HANDLING PRECAUTIONS.....	25
8.2 SAFETY PRECAUTIONS .....	26

9. DEFINITION OF LABELS.....	27
9.1 OPEN CELL LABEL.....	27
10. PACKAGING.....	29
10.1 PACKAGING SPECIFICATIONS .....	29
10.2 PACKAGING METHOD.....	29
11. MECHANICAL CHARACTERISTIC .....	31

**REVISION HISTORY**

Version	Date	Page(New)	Section	Description
Ver. 2.0	Nov. 16, 2012	All	All	The Approval Specification was first issued.
Ver. 2.1	Jan. 03, 2013	18	6.1	Update min/Max value of frame rate.

1. GENERAL DESCRIPTION

1.1 OVERVIEW

V390HJ-PE1 is a 39" TFT Liquid Crystal Display product with driver ICs and 2ch-LVDS interface. This product supports 1920 x 1080 Full HD TV format and can display 16.7M colors (8-bit). The backlight unit is not built in.

1.2 FEATURES

CHARACTERISTICS ITEMS	SPECIFICATIONS
Screen Diagonal [in]	39
Pixels [lines]	1920 × 1080
Active Area [mm]	853.92(H) × 480.33(V) (38.5" diagonal)
Sub-Pixel Pitch [mm]	0.14825(H) × 0.44475(V)
Pixel Arrangement	RGB Vertical Stripe
Weight [g]	1260 Typ. (g)
Physical Size [mm]	874.86(W) × 522.53 (H) × 2.8(D) Typ.
Display Mode	Transmissive Mode / Normally Black
Contrast Ratio	Typ. 2000:1 (Typical value measure by CMI's Module)
Glass thickness (Array / CF) [mm]	0.5 / 0.5
Viewing Angle (CR>20)	Typ. +88/-88(H), +88/-88(V) (CR ≥ 20) (Typical value measured by CMI's module)
Color Chromaticity	R = (0.643, 0.329) G = (0.279, 0.589) B = (0.133, 0.111) W = (0.311, 0.347) * Please refer to "color chromaticity" in 7.2
Cell Transparency [%]	(5.8%) * Please refer to "Center Transmittance" in 7.2
Polarizer Surface Treatment	Anti-Glare coating (Haze 1%)
Rotation Function	Unachievable
Display Orientation	Signal input with "CMI"

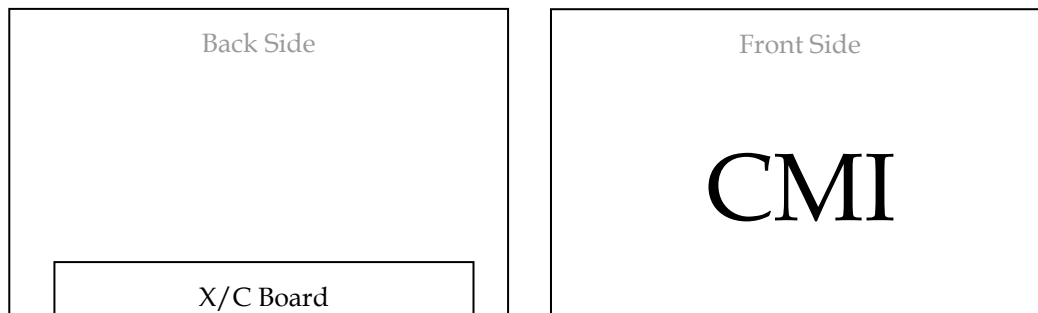

1.3 MECHANICAL SPECIFICATIONS

Item	Min.	Typ.	Max.	Unit	Note
Weight	1210	1260	1310	g	-
I/F connector mounting position	The mounting inclination of the connector makes the screen center within $\pm 0.5\text{mm}$ as the horizontal.				(2)

Note (1) Please refer to the attached drawings for more information of front and back outline dimensions.

Note (2) Connector mounting position

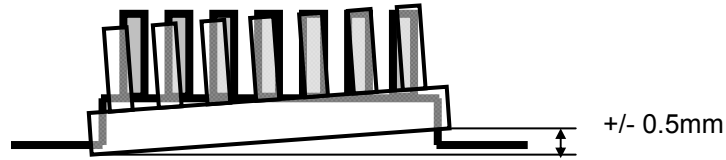

**2. ABSOLUTE MAXIMUM RATINGS**

**2.1 ABSOLUTE RATINGS OF ENVIRONMENT**

Item	Symbol	Value		Unit	Note
		Min.	Max.		
Storage Temperature	TST	-20	+60	°C	(1) With CMI Module
Operating Ambient Temperature	TOP	0	50	°C	(1), (2) With CMI Module

Note (1) Temperature and relative humidity range is shown in the figure below.

- (a) 90 %RH Max. ( $T_a \leq 40\text{ }^\circ\text{C}$ ).
- (b) Wet-bulb temperature should be 39 °C Max. ( $T_a > 40\text{ }^\circ\text{C}$ ).
- (c) No condensation.

Note (2) Thermal management should be considered in final product design to prevent the surface temperature of display area from being over 65 °C. The range of operating temperature may degrade in case of improper thermal management in final product design.

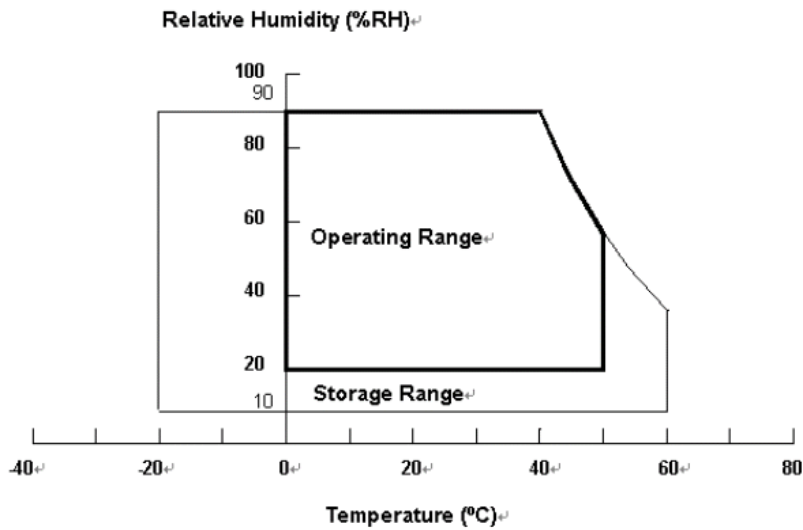

**2.2 ABSOLUTE RATINGS OF ENVIRONMENT (OPEN CELL)**

Recommended Storage Condition: With shipping package.

Recommended Storage temperature range: 25±5 °C

Recommended Storage humidity range: 50±10%RH

Recommended Shelf life: a month

**2.3 ELECTRICAL ABSOLUTE RATINGS**

**2.3.1 TFT LCD MODULE**

Item	Symbol	Value		Unit	Note
		Min.	Max.		
Power Supply Voltage	VCC	-0.3	13.5	V	(1)
Logic Input Voltage	VIN	-0.3	3.6	V	

Note (1) Permanent damage to the device may occur if maximum values are exceeded. Function operation should be restricted to the conditions described under Normal Operating Conditions.



3. ELECTRICAL CHARACTERISTICS

3.1 TFT LCD OPEN CELL

(Ta = 25 ± 2 °C)

Parameter	Symbol	Value			Unit	Note	
		Min.	Typ.	Max.			
Power Supply Voltage	V <sub>CC</sub>	10.8	12	13.2	V	(1)	
Rush Current	I <sub>RUSH</sub>	—	—	2.64	A	(2)	
Power consumption	White Pattern	P <sub>T</sub>	—	4.32	W	(3)	
	Black Pattern	P <sub>T</sub>	—	4.2			
	Horizontal Stripe	P <sub>T</sub>	—	6.96			
Power Supply Current	White Pattern	P <sub>T</sub>	—	0.36	A		
	Black Pattern	P <sub>T</sub>	—	0.35			
	Horizontal Stripe	P <sub>T</sub>	—	0.58			
LVDS interface	Differential Input High Threshold Voltage	V <sub>LVTH</sub>	+100	—	+300	mV	(4)
	Differential Input Low Threshold Voltage	V <sub>LVTL</sub>	-300	—	-100	mV	
	Common Input Voltage	V <sub>CM</sub>	1.0	1.2	1.4	V	
	Differential input voltage	V <sub>ID</sub>	200	—	600	mV	
	Terminating Resistor	R <sub>T</sub>	—	100	—	ohm	
CMOS interface	Input High Threshold Voltage	V <sub>IH</sub>	2.7	—	3.3	V	
	Input Low Threshold Voltage	V <sub>IL</sub>	0	—	0.7	V	

Note (1) The module should be always operated within the above ranges.

The ripple voltage should be controlled under 10% of V<sub>CC</sub> (Typ.).

Note (2) Measurement condition :

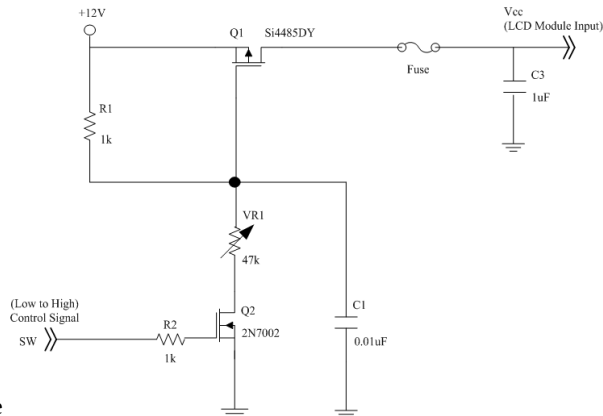

Note

dissipation check pattern below is displayed.

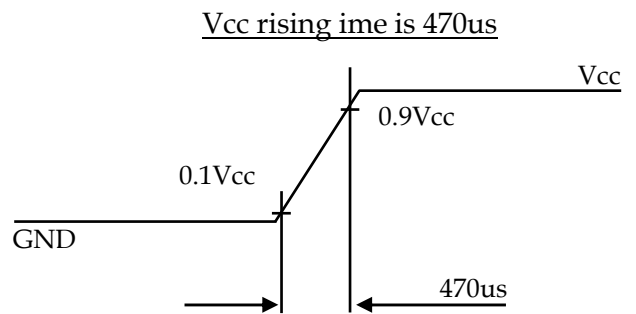

ditions at V<sub>CC</sub> = 12 V, Ta = 25 ± 2 °C, f<sub>v</sub> = 60 Hz, whereas a power

a. White Pattern

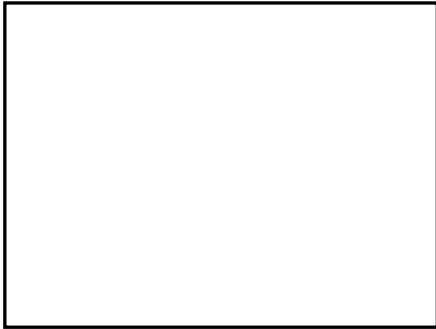

Active Area

b. Black Pattern



Active Area

c. Heavy Loading pattern Ex: Horizontal Stripe (by cell and platform)

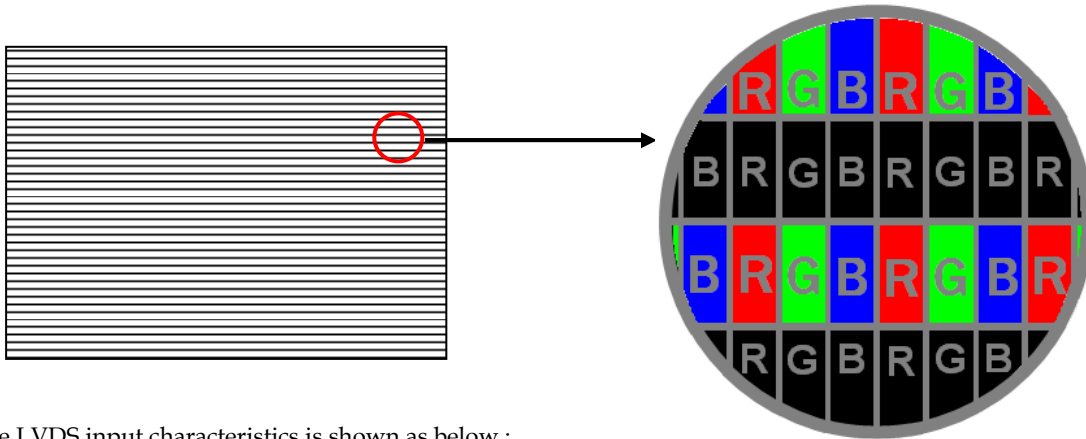

Note (4) The LVDS input characteristics is shown as below :

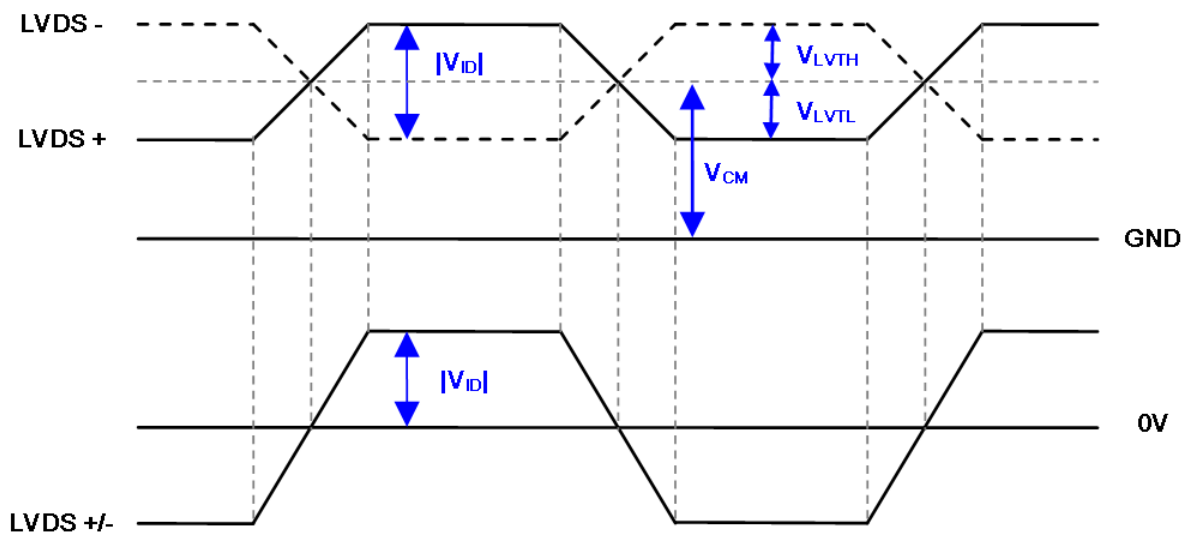

4. INPUT TERMINAL PIN ASSIGNMENT

4.1 TFT LCD OPEN CELL

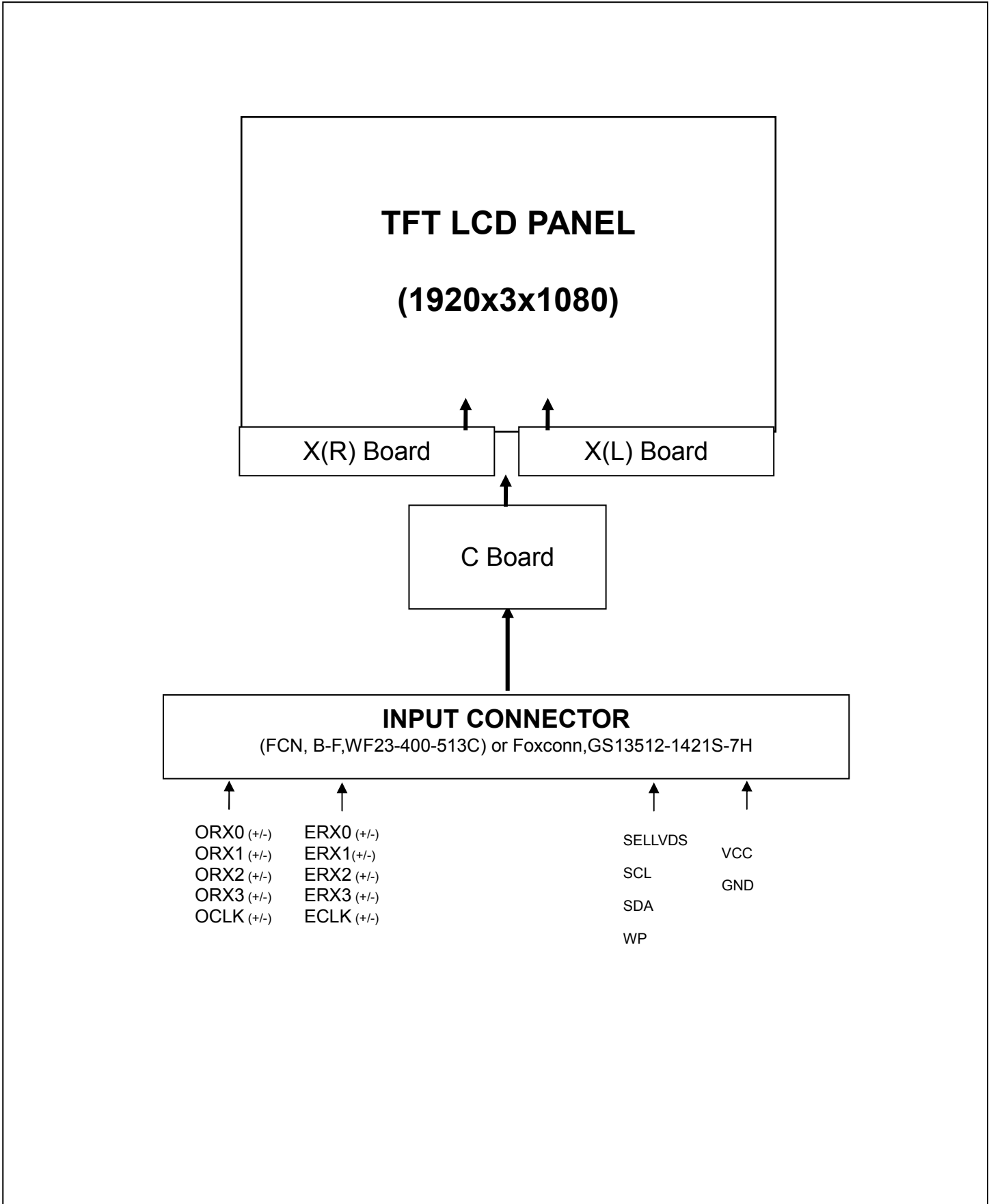

## 5. INPUT TERMINAL PIN ASSIGNMENT

### 5.1 TFT LCD OPEN CELL INPUT

CNF1 Connector Part No.: WF23-400-513C,(FCN) or Foxconn,GS13512-1421S-7H.

Matting connector : JAE FI-RE51HL

Pin	Name	Description	Note
1	N.C.	No Connection	(2)
2	N.C.	No Connection	
3	N.C.	No Connection	
4	N.C.	No Connection	
5	N.C.	No Connection	
6	N.C.	No Connection	
7	SELLVDS	LVDS data format Selection (0V~0.7V→JEIDA, 2.7V~3.3V/OPEN→VESA) 【No Floating】	(3)(4)
8	N.C.	No Connection	(2)
9	N.C.	No Connection	
10	N.C.	No Connection	
11	GND	Ground	(5)
12	ORX0-	Odd pixel Negative LVDS differential data input. Channel 0	
13	ORX0+	Odd pixel Positive LVDS differential data input. Channel 0	
14	ORX1-	Odd pixel Negative LVDS differential data input. Channel 1	
15	ORX1+	Odd pixel Positive LVDS differential data input. Channel 1	
16	ORX2-	Odd pixel Negative LVDS differential data input. Channel 2	
17	ORX2+	Odd pixel Positive LVDS differential data input. Channel 2	
18	GND	Ground	
19	OCLK-	Odd pixel Negative LVDS differential clock input.	
20	OCLK+	Odd pixel Positive LVDS differential clock input.	(5)
21	GND	Ground	(5)
22	ORX3-	Odd pixel Negative LVDS differential data input. Channel 3	
23	ORX3+	Odd pixel Positive LVDS differential data input. Channel 3	
24	N.C.	No Connection	(2)
25	N.C.	No Connection	
26	N.C.	No Connection	
27	N.C.	No Connection	
28	ERX0-	Even pixel Negative LVDS differential data input. Channel 0	(5)
29	ERX0+	Even pixel Positive LVDS differential data input. Channel 0	
30	ERX1-	Even pixel Negative LVDS differential data input. Channel 1	
31	ERX1+	Even pixel Positive LVDS differential data input. Channel 1	
32	ERX2-	Even pixel Negative LVDS differential data input. Channel 2	
33	ERX2+	Even pixel Positive LVDS differential data input. Channel 2	
34	GND	Ground	(5)
35	ECLK-	Even pixel Negative LVDS differential clock input	
36	ECLK+	Even pixel Positive LVDS differential clock input	
37	GND	Ground	(5)
38	ERX3-	Even pixel Negative LVDS differential data input. Channel 3	
39	ERX3+	Even pixel Positive LVDS differential data input. Channel 3	(5)
40	N.C.	No Connection	(2)
41	N.C.	No Connection	
42	GND	Ground	(2)
43	GND	Ground	
44	GND	Ground	
45	GND	Ground	
46	GND	Ground	

47	N.C.	No Connection	(2)
48	VCC	Power input (+12V)	
49	VCC	Power input (+12V)	
50	VCC	Power input (+12V)	
51	VCC	Power input (+12V)	

Note (1) LVDS connector pin order defined as below

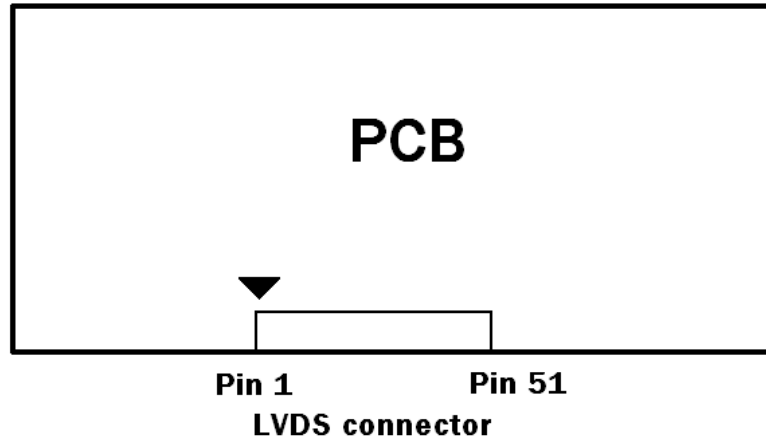

Note (2) Reserved for internal use. Please leave it open.

Note (3) Connect to Open or +3.3V: VESA Format, connect to GND: JEIDA Format.

SELLVDS	Mode
L	JEIDA
H, OPEN(default)	VESA

L : Connect to GND, H: Connect to +3.3V

Note (4) Interface optional pin has internal scheme as following diagram. Customer should keep the interface voltage level requirement which including Panel board loading as below.

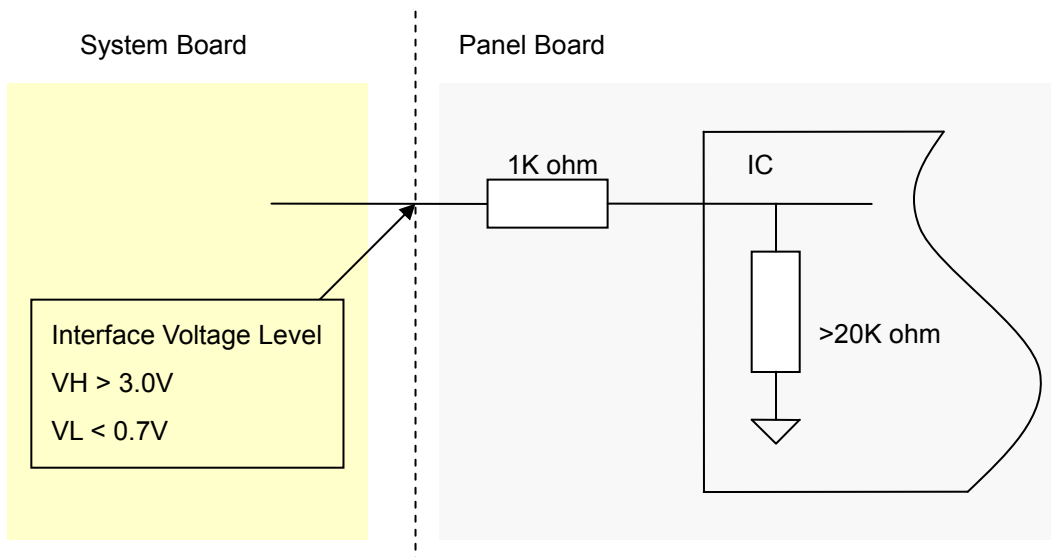

Note (5) Two pixel data send into the module for every clock cycle. The first pixel of the frame is odd pixel and the second pixel is even pixel.

Note (6) LVDS connector mating dimension range request is 0.93mm~1.0mm as below.

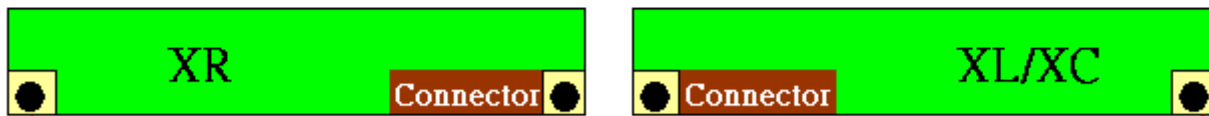
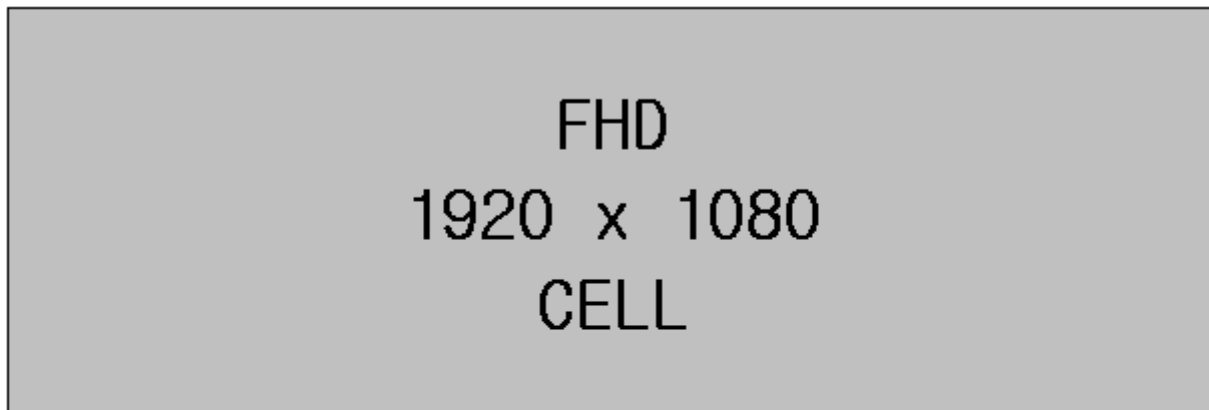
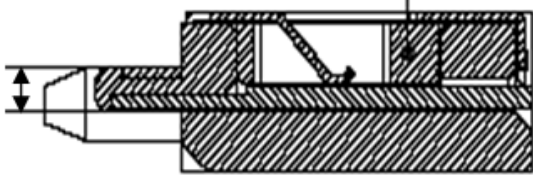

The screw hole which is distant from the connector is merged with Ground.

5.2 LVDS INTERFACE

JEIDA Format : SELLVDS = L

VESA Format : SELLVDS = H or Open

VESA LVDS format

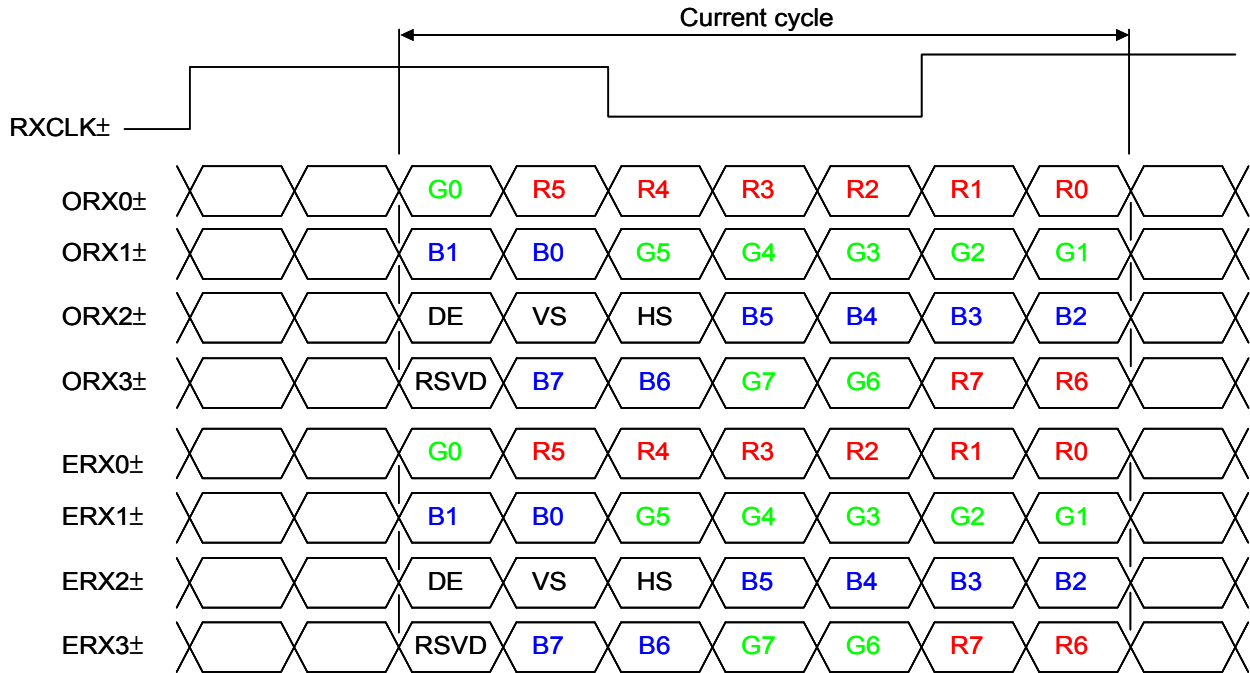

JEDIA LVDS format

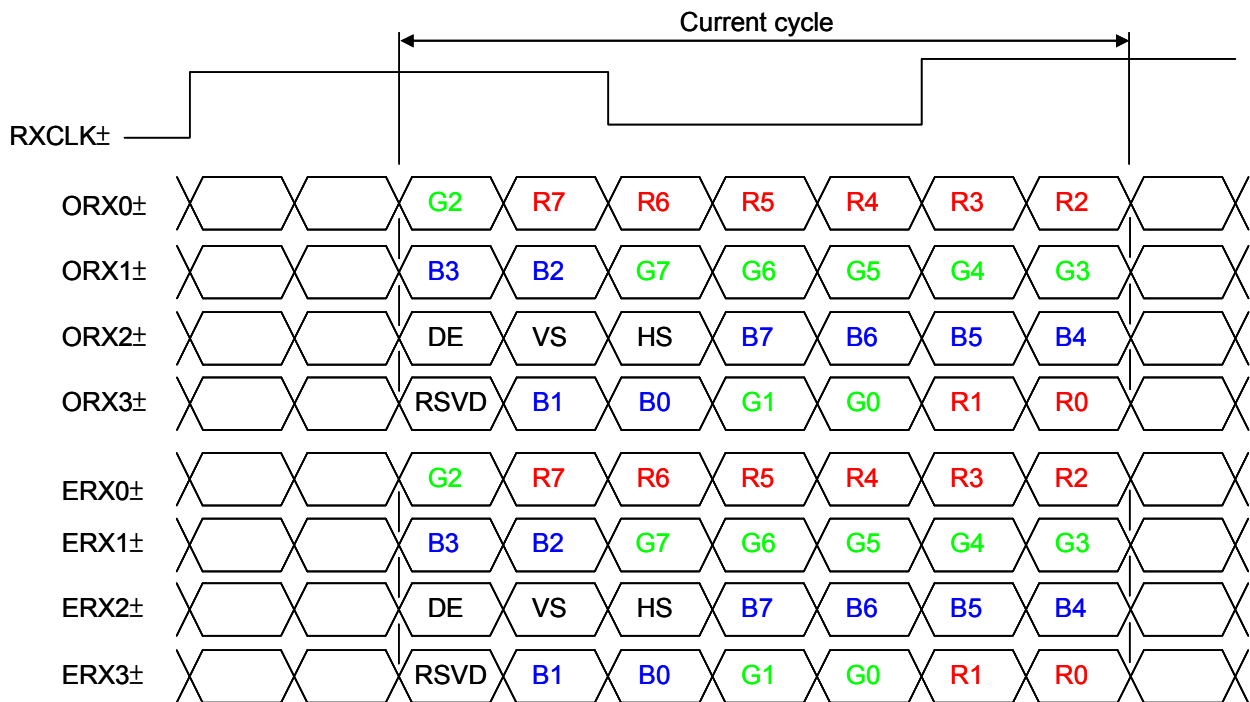

5.3 COLOR DATA INPUT ASSIGNMENT

The brightness of each primary color (red, green and blue) is based on the 8-bit gray scale data input for the color. The higher the binary input, the brighter the color. The table below provides the assignment of the color versus data input.

Color		Data Signal																							
		Red								Green								Blue							
		R7	R6	R5	R4	R3	R2	R1	R0	G7	G6	G5	G4	G3	G2	G1	G0	B7	B6	B5	B4	B3	B2	B1	B0
Basic Colors	Black	0	0	0	0	0	0	0	0	0	0	0	0	0	0	0	0	0	0	0	0	0	0	0	0
	Red	1	1	1	1	1	1	1	1	0	0	0	0	0	0	0	0	0	0	0	0	0	0	0	0
	Green	0	0	0	0	0	0	0	0	1	1	1	1	1	1	1	1	0	0	0	0	0	0	0	0
	Blue	0	0	0	0	0	0	0	0	0	0	0	0	0	0	0	0	1	1	1	1	1	1	1	1
	Cyan	0	0	0	0	0	0	0	0	1	1	1	1	1	1	1	1	1	1	1	1	1	1	1	1
	Magenta	1	1	1	1	1	1	1	1	0	0	0	0	0	0	0	0	1	1	1	1	1	1	1	1
	Yellow	1	1	1	1	1	1	1	1	1	1	1	1	1	1	1	1	0	0	0	0	0	0	0	0
	White	1	1	1	1	1	1	1	1	1	1	1	1	1	1	1	1	1	1	1	1	1	1	1	1
Gray Scale Of Red	Red (0) / Dark	0	0	0	0	0	0	0	0	0	0	0	0	0	0	0	0	0	0	0	0	0	0	0	
	Red (1)	0	0	0	0	0	0	0	1	0	0	0	0	0	0	0	0	0	0	0	0	0	0	0	
	Red (2)	0	0	0	0	0	0	1	0	0	0	0	0	0	0	0	0	0	0	0	0	0	0	0	
	:	:	:	:	:	:	:	:	:	:	:	:	:	:	:	:	:	:	:	:	:	:	:	:	
	:	:	:	:	:	:	:	:	:	:	:	:	:	:	:	:	:	:	:	:	:	:	:	:	
	Red (253)	1	1	1	1	1	1	0	1	0	0	0	0	0	0	0	0	0	0	0	0	0	0	0	
	Red (254)	1	1	1	1	1	1	1	0	0	0	0	0	0	0	0	0	0	0	0	0	0	0	0	
	Red (255)	1	1	1	1	1	1	1	1	0	0	0	0	0	0	0	0	0	0	0	0	0	0	0	
Gray Scale Of Green	Green (0) / Dark	0	0	0	0	0	0	0	0	0	0	0	0	0	0	0	0	0	0	0	0	0	0	0	
	Green (1)	0	0	0	0	0	0	0	0	0	0	0	0	0	0	1	0	0	0	0	0	0	0	0	
	Green (2)	0	0	0	0	0	0	0	0	0	0	0	0	0	1	0	0	0	0	0	0	0	0	0	
	:	:	:	:	:	:	:	:	:	:	:	:	:	:	:	:	:	:	:	:	:	:	:	:	
	:	:	:	:	:	:	:	:	:	:	:	:	:	:	:	:	:	:	:	:	:	:	:	:	
	Green (253)	0	0	0	0	0	0	0	0	1	1	1	1	1	1	0	1	0	0	0	0	0	0	0	
	Green (254)	0	0	0	0	0	0	0	0	1	1	1	1	1	1	1	0	0	0	0	0	0	0	0	
	Green (255)	0	0	0	0	0	0	0	0	1	1	1	1	1	1	1	1	0	0	0	0	0	0	0	
Gray Scale Of Blue	Blue (0) / Dark	0	0	0	0	0	0	0	0	0	0	0	0	0	0	0	0	0	0	0	0	0	0	0	
	Blue (1)	0	0	0	0	0	0	0	0	0	0	0	0	0	0	0	0	0	0	0	0	0	0	1	
	Blue (2)	0	0	0	0	0	0	0	0	0	0	0	0	0	0	0	0	0	0	0	0	0	1	0	
	:	:	:	:	:	:	:	:	:	:	:	:	:	:	:	:	:	:	:	:	:	:	:	:	
	:	:	:	:	:	:	:	:	:	:	:	:	:	:	:	:	:	:	:	:	:	:	:	:	
	Blue (253)	0	0	0	0	0	0	0	0	0	0	0	0	0	0	0	1	1	1	1	1	1	0	1	
	Blue (254)	0	0	0	0	0	0	0	0	0	0	0	0	0	0	0	1	1	1	1	1	1	1	0	
	Blue (255)	0	0	0	0	0	0	0	0	0	0	0	0	0	0	0	1	1	1	1	1	1	1	1	

Note (1) 0: Low Level Voltage, 1: High Level Voltage



5.4 FLICKER (Vcom) ADJUSTMENT

(1) Adjustment Pattern :

The adjustment pattern is shown as below. If customer needs below pattern, please directly contact with CMI account FAE.

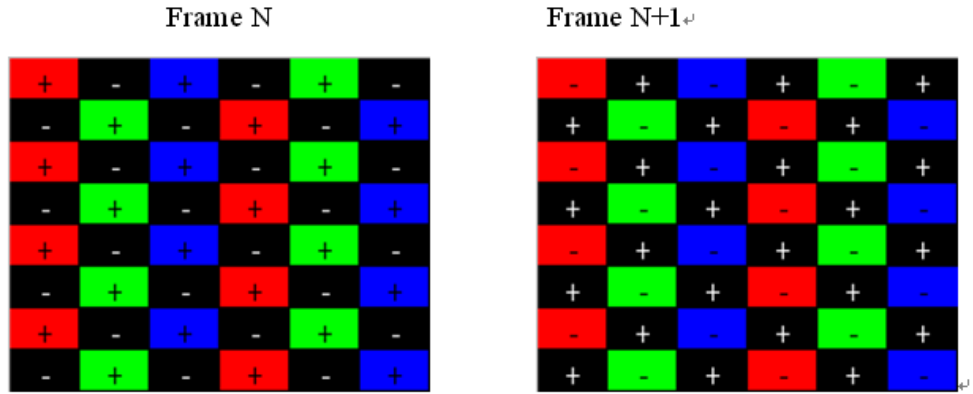

(2) Adjustment method: (Digital V-com)

Programmable memory IC is used for Digital V-com adjustment in this model. CMI provide Auto Vcom tools to adjust Digital V-com. The detail connection and setting instruction, please directly contact with Account FAE or refer CMI Auto V-com adjustment OI. Below items is suggested to be ready before Digital V-com adjustment in customer LCM line.

- a. USB Sensor Board.
- b. Programmable software.
- c. Document: Auto V-com adjustment suggestion OI.

6. INTERFACE TIMING

6.1 INPUT SIGNAL TIMING SPECIFICATIONS

The input signal timing specifications are shown as the following table and timing diagram.

Signal	Item	Symbol	Min.	Typ.	Max.	Unit	Note	
LVDS Receiver Clock	Frequency	$F_{clk_{in}}$ ( $=1/TC$ )	60	74.25	80	MHz		
	Input cycle to cycle jitter	$T_{rcl}$	-	-	200	ps	(3)	
	Spread spectrum modulation range	$F_{clk_{in\_mod}}$	$F_{clk_{in}}-2\%$	-	$F_{clk_{in}}+2\%$	MHz	(4)	
	Spread spectrum modulation frequency	$F_{SSM}$	-	-	200	KHz		
LVDS Receiver Data	Receiver Skew Margin	$T_{RSKM}$	-400	-	400	ps	(5)	
Vertical Active Display Term	Frame Rate	$F_{r5}$	47	50	53	Hz	$T_v=T_{vd}+T_{vb}$	
		$F_{r6}$	57	60	63	Hz		
	Total	$T_v$	1115	1125	1135	Th		
	Display	$T_{vd}$	1080	1080	1080	Th		-
	Blank	$T_{vb}$	35	45	55	Th		-
Horizontal Active Display Term	Total	$T_h$	1030	1100	1325	$T_c$	$T_h=T_{hd}+T_{hb}$	
	Display	$T_{hd}$	960	960	960	$T_c$	-	
	Blank	$T_{hb}$	70	140	365	$T_c$	-	

Note (1) Please make sure the range of pixel clock has follow the below equation :

$$F_{clk_{in}}(\max) \geq F_{r6} \times T_v \times T_h$$

$$F_{r5} \times T_v \times T_h \geq F_{clk_{in}}(\min)$$

Note (2) This module is operated in DE only mode and please follow the input signal timing diagram below :

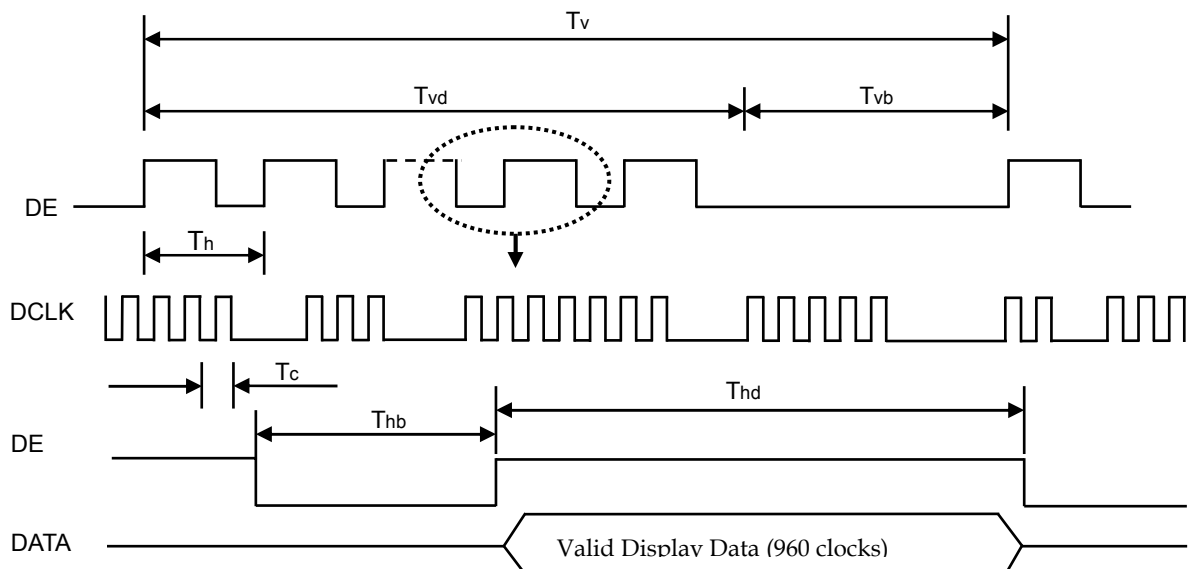

Note (3) The input clock cycle-to-cycle jitter is defined as below figures.  $Trcl = |T_1 - T|$

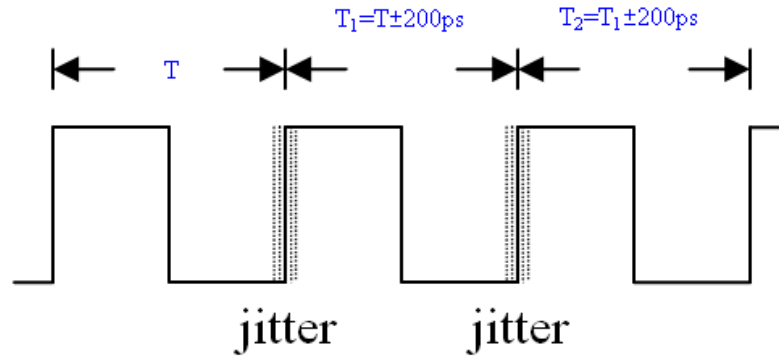

Note (4) The SSCG (Spread spectrum clock generator) is defined as below figures.

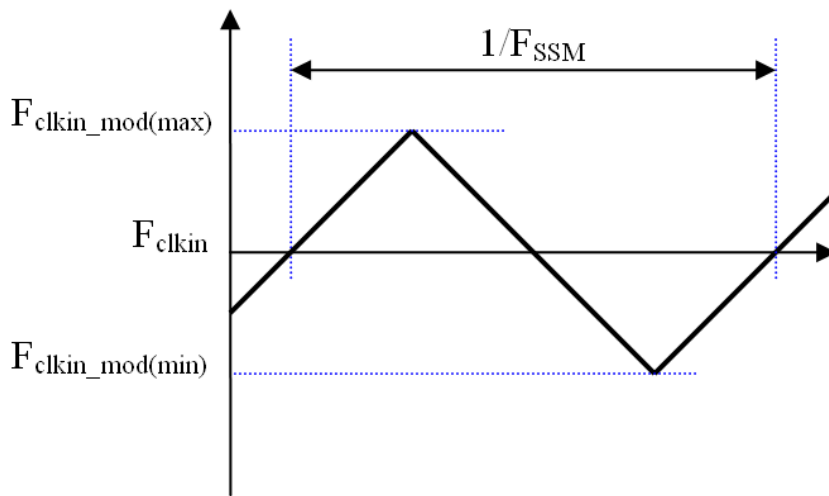

Note (5) The LVDS timing diagram and the receiver skew margin is defined and shown in following figure.

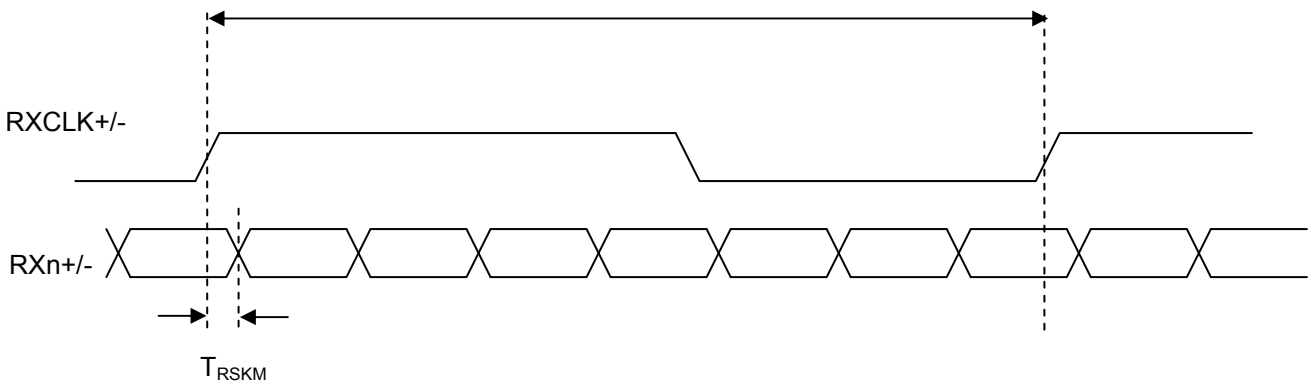

6.2 POWER ON/OFF SEQUENCE

To prevent a latch-up or DC operation of LCD module, the power on/off sequence should be as the diagram below.

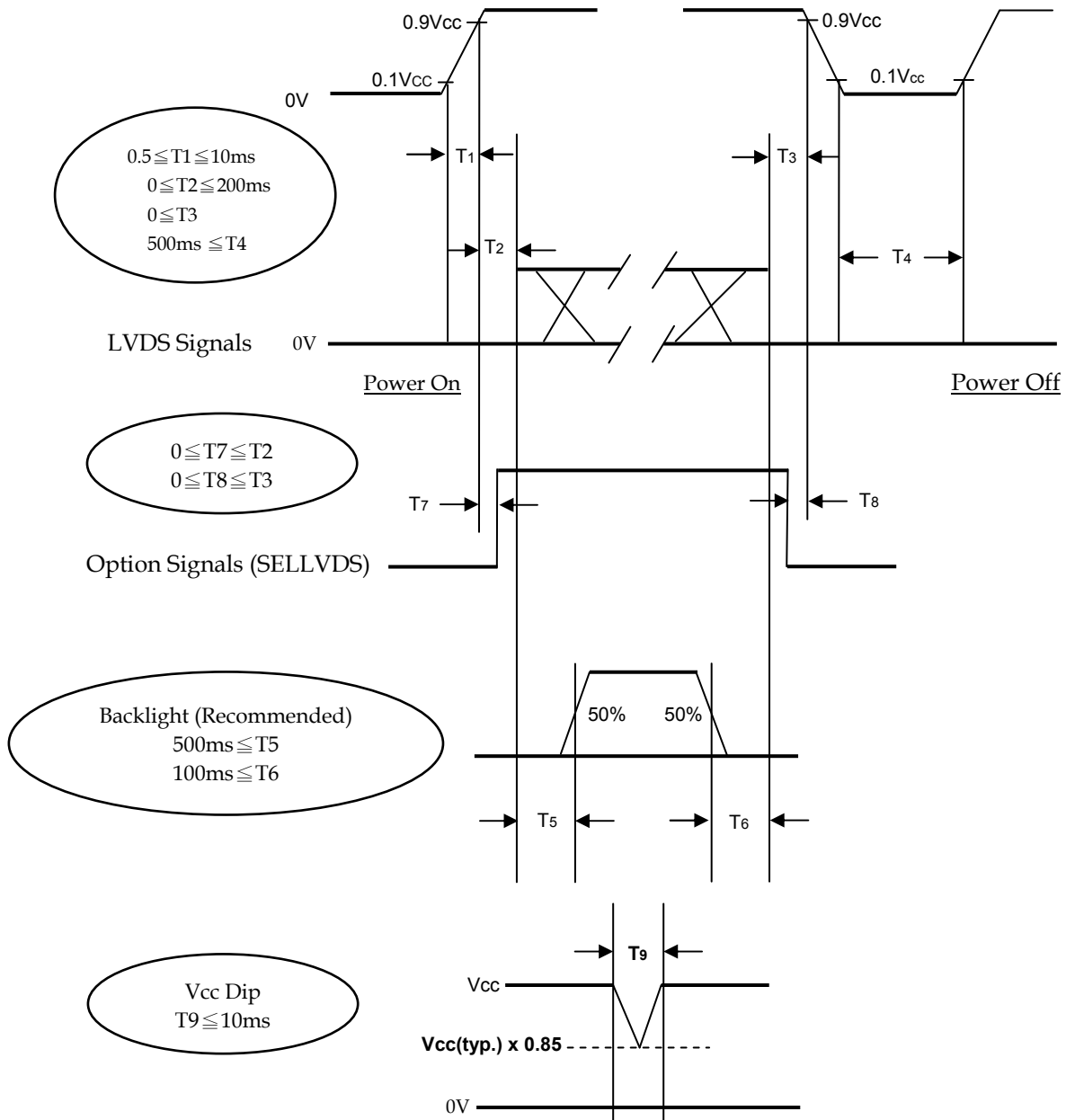

- Note (1) The supply voltage of the external system for the module input should follow the definition of Vcc.
- Note (2) Apply the lamp voltage within the LCD operation range. When the backlight turns on before the LCD operation or the LCD turns off before the backlight turns off, the display may momentarily become abnormal screen.
- Note (3) In case of VCC is in off level, please keep the level of input signals on the low or high impedance.  
If  $T2 < 0$ , that maybe cause electrical overstress failure.
- Note (4) T4 should be measured after the module has been fully discharged between power off and on period.
- Note (5) Interface signal shall not be kept at high impedance when the power is on.
- Note (6) Vcc must decay smoothly when power-off.

7. OPTICAL CHARACTERISTICS

7.1 TEST CONDITIONS

Item	Symbol	Value	Unit
Ambient Temperature	Ta	25 ±2	°C
Ambient Humidity	Ha	50 ±10	%RH
Vertical Frame Rate	Fr	60	Hz
Supply Voltage	V <sub>CC</sub>	12.0 ±1.2	V
Input Signal	According to typical value in "3. ELECTRICAL CHARACTERISTICS"		
LED Current	I <sub>L</sub>	145 ±4	mA

The LCD module should be stabilized at given temperature for 1 hour to avoid abrupt temperature change during measuring in a windless room.

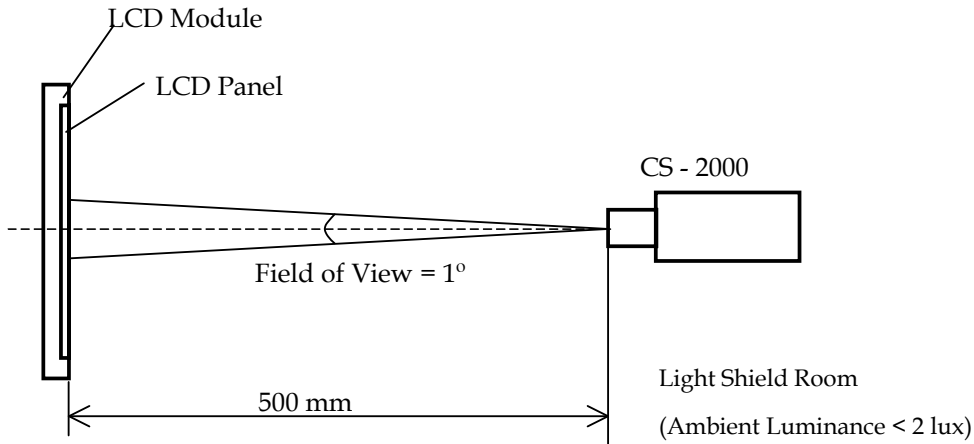

7.2 OPTICAL SPECIFICATIONS

The relative measurement methods of optical characteristics are shown as below. The following items should be measured under the test conditions described in 7.1 and stable environment shown in 7.1.

Item		Symbol	Condition	Min.	Typ.	Max.	Unit	Note
Color Chromaticity	Red	Rcx	Viewing Angle at Normal Direction Standard light source "C"	-0.03	0.643	+0.03	-	(0)
		Rcy			0.329		-	
	Green	Gcx			0.279		-	
		Gcy			0.589		-	
	Blue	Bcx			0.133		-	
		Bcy			0.111		-	
	White	Wcx			0.311		-	
		Wcy			0.347		-	
Transmittance		T%	$\theta_x=0^\circ, \theta_Y=0^\circ$ With CMI Module@60Hz	-	5.8	-	-	(1),(5)
Transmittance Variation		$\delta T$				1.3		(1),(6)
Contrast Ratio		CR		1400	2000	-	-	(1),(3)
Response Time		Gray to gray	$\theta_x=0^\circ, \theta_Y=0^\circ$ With CMI Module@60Hz	-	9.5	19	ms	(1),(4)
Viewing Angle	Horizontal	$\theta_{x+}$	CR $\geq$ 20 With CMI Module		88	-	Deg.	(1),(2)
		$\theta_{x-}$			88	-		
	Vertical	$\theta_{Y+}$			88	-		
		$\theta_{Y-}$			88	-		

Note (0) Light source is the standard light source "C" which is defined by CIE and driving voltage are based on suitable gamma voltages. The calculating method is as following :

- 1.Measure Module's and BLU's spectrum at center point. W, R,G, B are with signal input. BLU (V390HJ1-LE1) is supplied by CMI.
- 2.Calculate cell's spectrum.
- 3.Calculate cell's chromaticity by using the spectrum of standard light source "C".

Note (1) Light source is the BLU which supplied by CMI and driving voltage are based on suitable gamma voltages.

Note (2) Definition of Viewing Angle ( $\theta_x, \theta_y$ ) :

Viewing angles are measured by Autronic Conoscope Cono-80 (or Eldim EZ-Contrast 160R)

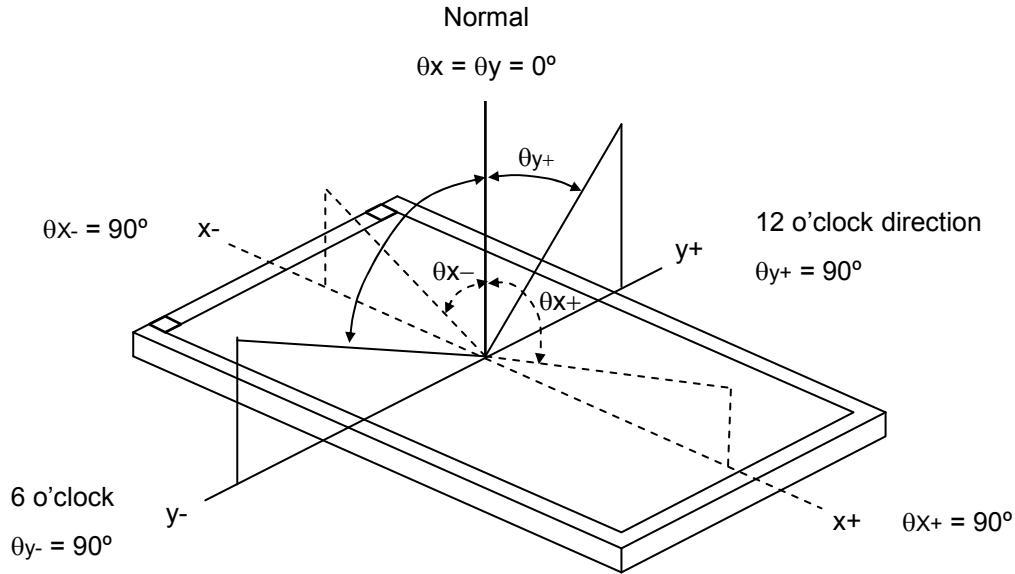

Note (3) Definition of Contrast Ratio (CR) :

The contrast ratio can be calculated by the following expression.

$$\text{Contrast Ratio (CR)} = \frac{\text{Surface Luminance of L255}}{\text{Surface Luminance of L0}}$$

L1023: Luminance of gray level 255

L 0: Luminance of gray level 0

CR = CR (5), where CR (X) is corresponding to the Contrast Ratio of the point X at the figure in Note (6).

Note (4) Definition of Gray-to-Gray Switching Time :

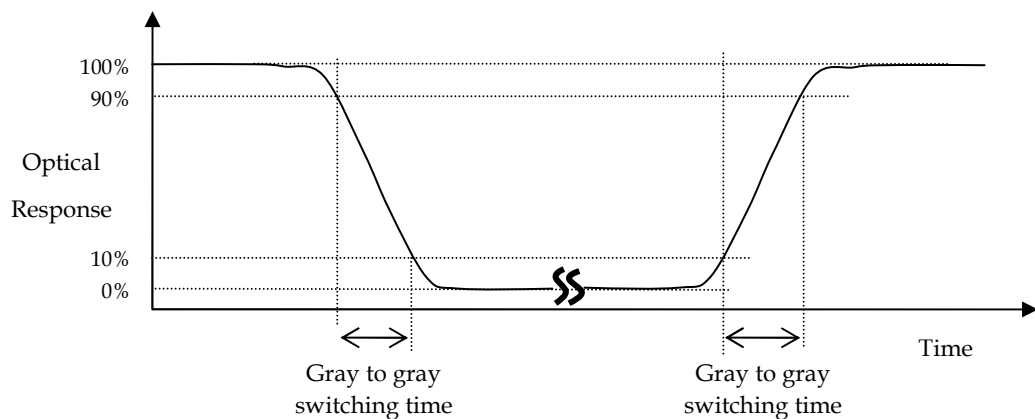

The driving signal means the signal of gray level 0, 31, 63, 95, 127, 159, 191, 223 and 255

Gray to gray average time means the average switching time of gray level 0, 31, 63, 95, 127, 159, 191, 223 and 255 to each other.

Note (5) Definition of Transmittance (T%) :

Measure the luminance of gray level 255 of LCD module and the luminance of BLU at 5 points.

$$\text{Transmittance (T\%)} = \frac{\text{average [L (1), L (2), L (3), L (4), L (5)] of LCD module}}{\text{average [L (1), L (2), L (3), L (4), L (5)] of BLU}} \times 100\%$$

The 5 point is corresponding of the point X at the figure in Note (6).

Note (6) Definition of Transmittance Variation ( $\delta T$ ) :

Measure the transmittance at 5 points.

The transmittance of each point can be calculated by the following expression.

$$T (X) = \text{L255 (X) of LCD module} / \text{Luminance (X) of BLU.}$$

L255: Luminance of gray level 255

$$\text{Transmittance Variation } (\delta T) = \frac{\text{Maximum [T (1), T (2), T (3), T (4), T (5)]}}{\text{Minimum [T (1), T (2), T (3), T (4), T (5)]}}$$

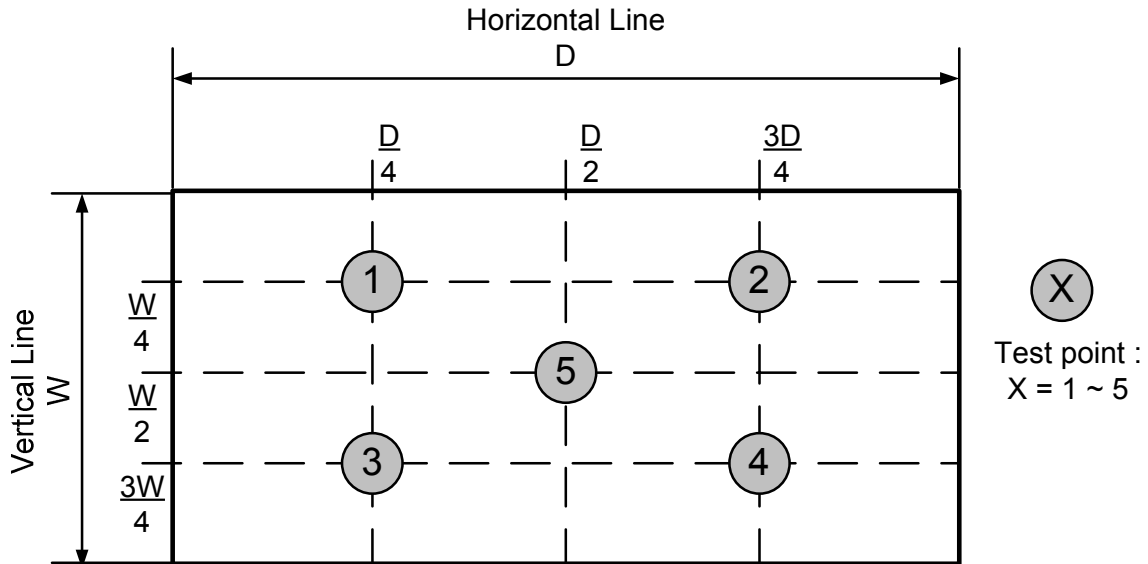



## 8. PRECAUTIONS

### 8.1 ASSEMBLY AND HANDLING PRECAUTIONS

- [ 1 ] Do not apply improper or unbalanced force such as bending or twisting to open cells during assembly.
- [ 2 ] It is recommended to assemble or to install an open cell into a customer's product in clean working areas.  
The dust and oil may cause electrical short to an open cell or worsen polarizers on an open cell.
- [ 3 ] Do not apply pressure or impulse to an open cell to prevent the damage.
- [ 4 ] Always follow the correct power-on sequence when an open cell is assembled and turned on. This can prevent the damage and latch-up of the CMOS LSI chips.
- [ 5 ] Do not design sharp-pointed structure / parting line / tooling gate on the plastic part of a COF (Chip on film), because the burr will scrape the COF.
- [ 6 ] If COF would be bended in assemble process, do not place IC on the bending corner.
- [ 7 ] The gap between COF IC and any structure of BLU must be bigger than 2 mm. This can prevent the damage of COF IC.
- [ 8 ] The bezel opening must have no burr and be smooth to prevent the surface of an open cell scraped.
- [ 9 ] The bezel of a module or a TV set can not contact with force on the surface of an open cell. It might cause light leakage or scrape.
- [ 10 ] In the case of no FFC or FPC attached with open cells, customers can refer the FFC / FPC drawing and buy them by self.
- [ 11 ] It is important to keep enough clearance between customers' front bezel/backlight and an open cell.  
Without enough clearance, the unexpected force during module assembly procedure may damage an open cell.
- [ 12 ] Do not plug in or unplug an I/F (interface) connector while an assembled open cell is in operation.
- [ 13 ] Use a soft dry cloth without chemicals for cleaning, because the surface of the polarizer is very soft and easily scratched.
- [ 14 ] Moisture can easily penetrate into an open cell and may cause the damage during operation.
- [ 15 ] When storing open cells as spares for a long time, the following precaution is necessary.
  - [ 15.1 ] Do not leave open cells in high temperature and high humidity for a long time. It is highly recommended to store open cells in the temperature range from 0 to 35°C at normal humidity without condensation.
  - [ 15.2 ] Open cells shall be stored in dark place. Do not store open cells in direct sunlight or fluorescent light environment.
- [ 16 ] When ambient temperature is lower than 10°C, the display quality might be reduced.
- [ 17 ] Unpacking (Cartons/Tray plates) in order to prevent open cells broken:
  - [ 17.1 ] Moving tray plates by one operator may cause tray plates bent which may induce open cells broken.  
Two operators carry one carton with their two hands. Do not throw cartons/tray plates, avoid any impact on cartons/tray plates, and put down & pile cartons/tray plates gently.
  - [ 17.2 ] A tray plate handled with unbalanced force may cause an open cell damaged. Trays should be completely put on a flat platform.
  - [ 17.3 ] To prevent open cells broken, tray plates should be moved one by one from a plastic bag.

- [ 17.4 ] Please follow the packing design instruction, such as the maximum number of tray stacking to prevent the deformation of tray plates which may cause open cells broken.
- [ 17.5 ] To prevent an open cell broken or a COF damaged on a tray, please follow the instructions below:
  - [17.5.1] Do not peel a polarizer protection film of an open cell off on a tray
  - [17.5.2] Do not install FFC or LVDS cables of an open cell on a tray
  - [17.5.3] Do not press the surface of an open cell on a tray.
  - [17.5.4] Do not pull X-board when an open cell placed on a tray.
- [ 18 ] Unpacking (Hard Box) in order to prevent open cells broken:
  - [ 18.1 ] Moving hard boxes by one operator may cause hard boxes fell down and open cells broken by abnormal methods. Two operators carry one hard box with their two hands. Do handle hard boxes carefully, such as avoiding impact, putting down, and piling up gently.
  - [ 18.2 ] To prevent hard boxes sliding from carts and falling down, hard boxes should be placed on a surface with resistance.
  - [ 18.3 ] To prevent an open cell broken or a COF damaged in a hard box, please follow the instructions below:
    - [18.3.1] Do not peel a polarizer protection film of an open cell off in a hard box.
    - [18.3.2] Do not install FFC or LVDS cables of an open cell in a hard box.
    - [18.3.3] Do not press the surface of an open cell in a hard box.
    - [18.3.4] Do not pull X-board when an open cell placed in a hard box.
- [ 19 ] Handling – In order to prevent open cells, COFs , and components damaged:
  - [ 19.1 ] The forced displacement between open cells and X-board may cause a COF damaged. Use a fixture tool for handling an open cell to avoid X-board vibrating and interfering with other components on a PCBA & a COF.
  - [ 19.2 ] To prevent open cells and COFs damaged by taking out from hard boxes, using vacuum jigs to take out open cells horizontally is recommended.
  - [ 19.3 ] Improper installation procedure may cause COFs of an open cell over bent which causes damages. As installing an open cell on a backlight or a test jig, place the bottom side of the open cell first on the backlight or the test jig and make sure no interference before fitting the open cell into the backlight/the test jig.
  - [ 19.4 ] Handle open cells one by one.
- [ 20 ] Avoid any metal or conductive material to contact PCB components, because it could cause electrical damage or defect.

## 8.2 SAFETY PRECAUTIONS

- [ 1 ] If the liquid crystal material leaks from the open cell, it should be kept away from the eyes or mouth. In case of contact with hands, skin or clothes, it has to be washed away thoroughly with soap.
- [ 2 ] After the end of life, open cells are not harmful in case of normal operation and storage.

9. DEFINITION OF LABELS

9.1 OPEN CELL LABEL

The barcode nameplate is pasted on each open cell as illustration for CMI internal control.

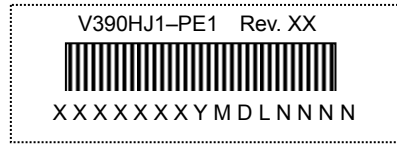
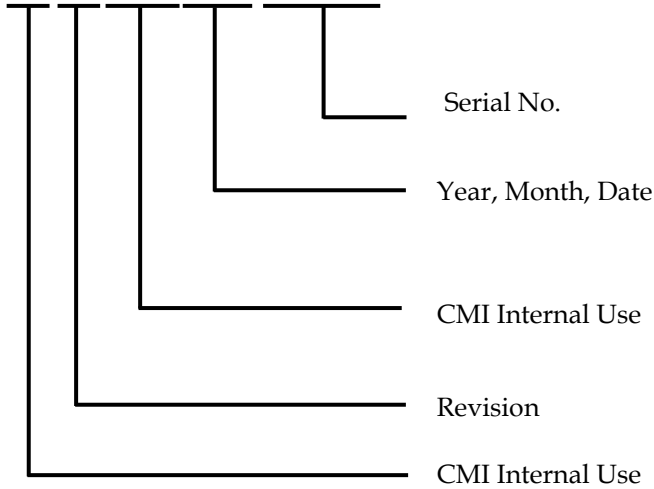

Figure.9-1 Serial No. Label on SPWB and Cell

Model Name : V390HJ1-PE1

Revision : Rev. XX, for example: A0, A1... B1, B2... or C1, C2...etc.

Serial ID : XXXXXX YMDLNNNN



Serial ID includes the information as below:

Manufactured Date:

Year: 2010=0, 2011=1,2012=2...etc.

Month: 1~9, A~C, for Jan. ~ Dec.

Day: 1~9, A~Y, for 1st to 31st, exclude I ,O, and U.

Revision Code: Cover all the change

Serial No.: Manufacturing sequence of product

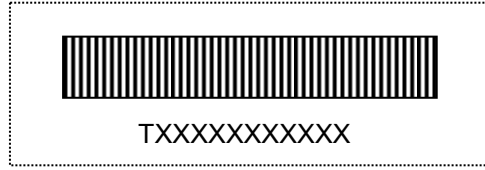
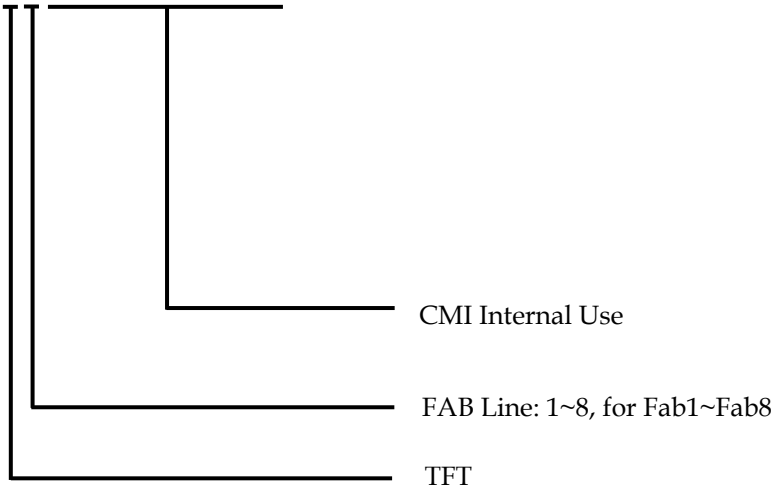

Figure.9-2 Panel ID Label on Cell

Panel ID Label includes the information as below :

Panel ID: T X X X X X X X X X X



10. PACKAGING

10.1 PACKAGING SPECIFICATIONS

- (1) 20 LCD TV Panels / 1 Box
- (2) Box dimensions : 980 (L) X 640 (W) X116 (H)mm
- (3) Weight : approximately 33Kg ( 20 panels per box)
- (4) 280 LCD TV Panels / 1 Group

10.2 PACKAGING METHOD

Packing method (Hard Box) is shown in following figures.

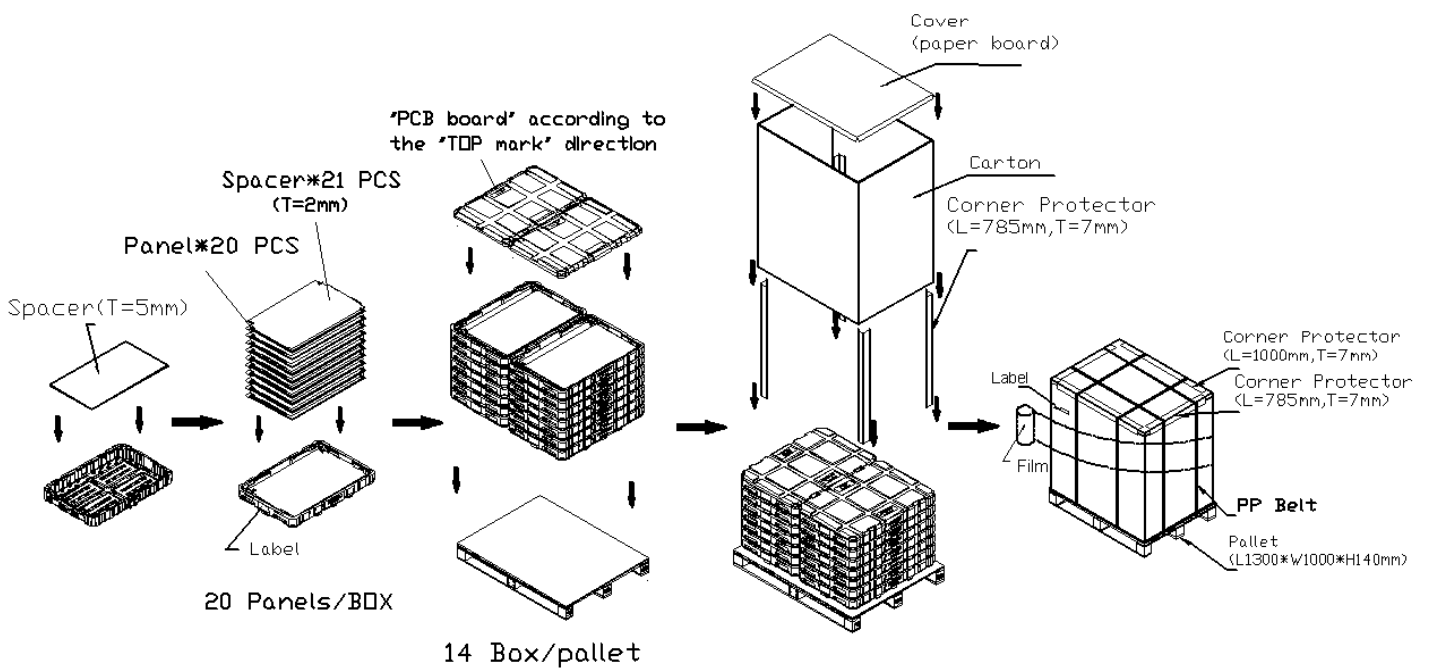

Sea / Land Transportation

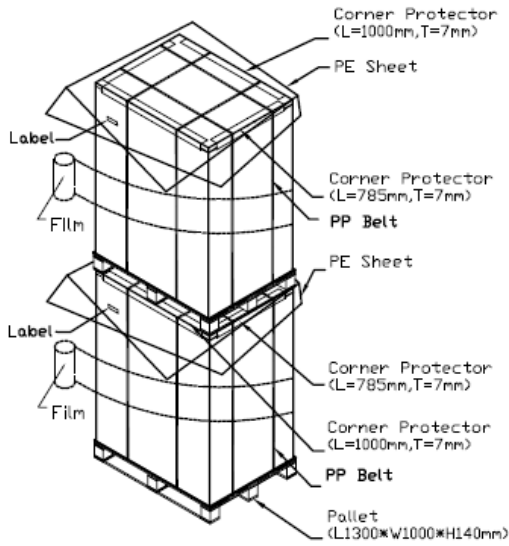

14 Box / Pallet +14 Box / Pallet

Air Transportation

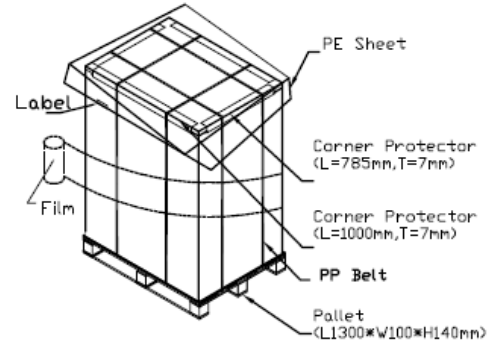

14 Box / Pallet

