

+5U

CS4  
CS3  
CS2  
CS1  
DEG

+5U

P503

UTTL  
HTTL  
H-LIN  
ROT.  
ACL  
MUTE  
STBY  
OFF  
SCL1  
SDA1

GND  
UIDEO+5U  
GND  
UFLB  
SW5U  
SCL1  
SDA1  
HFLB1  
CLBL  
GND  
ABL  
G1  
P502A

P503A

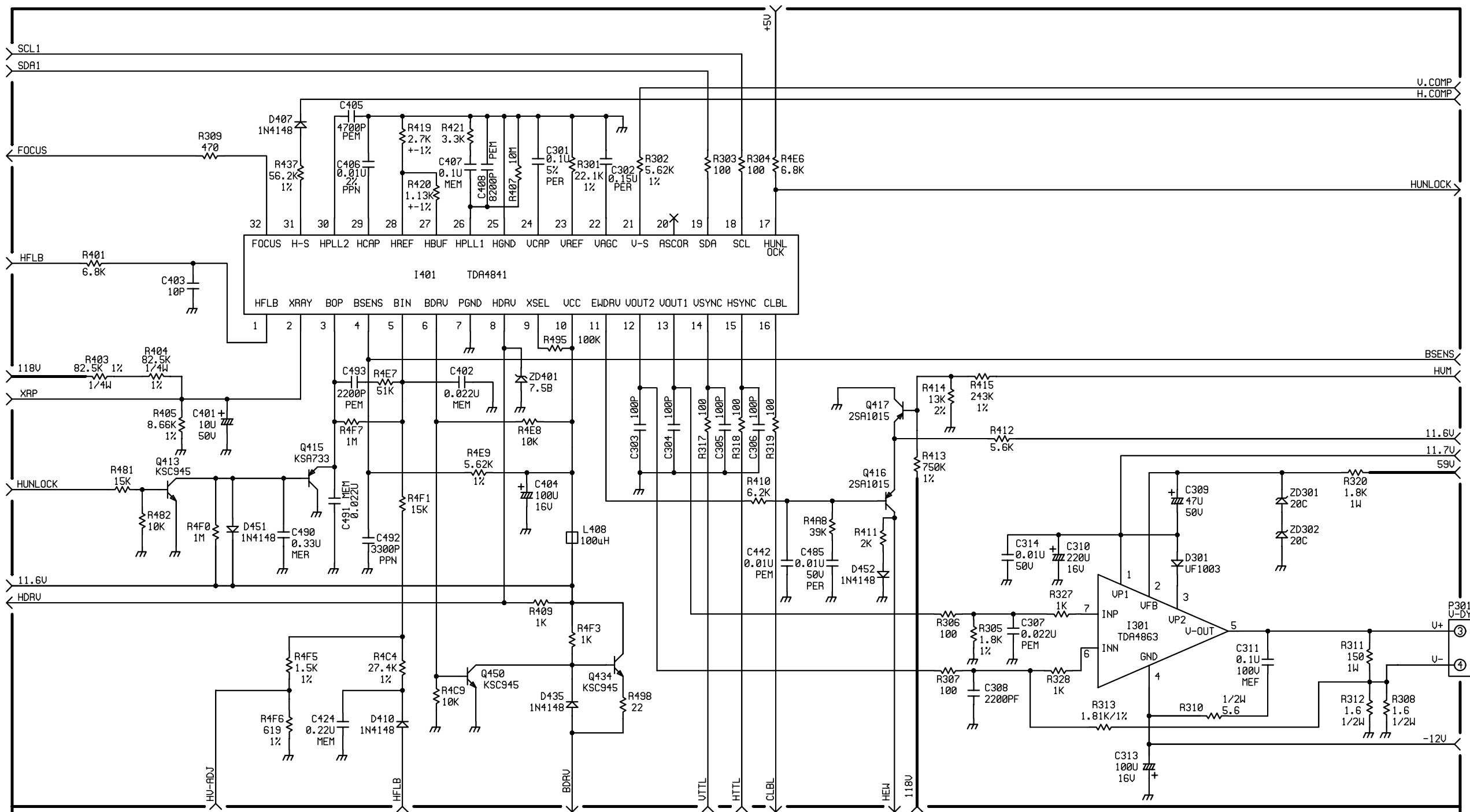

DRAWN :	DATE :	LITE-ON TECHNOLOGY CO.	
BETTY WU	06/14/01	TITLE :	
CHECK :	DATE :	C1770NSL/T MPS CKT.	
APPRO :	DATE :	DWG. NO :	A1
DESING :	DATE :	8915630000-02	
CHECK :	DATE :	PCB. NO :	SHEET :
APPRO :	DATE :	6831156300-02	1 OF 1

