

# HCD-EH15

## SERVICE MANUAL

Ver. 1.0 2008.04



*Canadian Model  
UK Model  
E Model  
Australian Model  
Russian Model*

- HCD-EH15 is the amplifier, CD player, tape deck and tuner section in CMT-EH15.

CD Section	Model Name Using Similar Mechanism	NEW
	Base Unit Name	BU-K8BD90-WOD
	Optical Pick-up Name	KSM-213CDP
Tape Section	Model Name Using Similar Mechanism	NEW
	Tape Transport Mechanism Type	MF-EH10

### SPECIFICATIONS

#### Amplifier section

European and Russian models:

DIN power output (rated): 4 + 4 W (4 ohms at 1 kHz, DIN)  
Continuous RMS power output (reference): 5 + 5 W (4 ohms at 1 kHz, 10% THD)  
Music power output (reference): 7 + 7 W

Other models:

DIN power output (rated): 4 + 4 W (4 ohms at 1 kHz, DIN)  
Continuous RMS power output (reference): 5 + 5 W (4 ohms at 1 kHz, 10% THD)

Inputs

AUDIO IN (stereo mini jack): Sensitivity 800 mV, impedance 47 kilohms

Outputs

PHONES (stereo mini jack): Accepts headphones with an impedance of 8 ohms or more  
SPEAKER: Accepts impedance of 4 ohms

#### CD player section

System: Compact disc and digital audio system

Laser Diode Properties

Emission Duration: Continuous

Laser Output\*: Less than 44.6µW

\* This output is the value measurement at a distance of 200 mm from the objective lens surface on the Optical Pick-up Block with 7 mm aperture.

Frequency response: 20 Hz – 20 kHz

Signal-to-noise ratio: More than 90 dB

Dynamic range: More than 90 dB

#### Tape deck section

Recording system: 4-track 2-channel, stereo

#### Tuner section

FM stereo, FM/AM superheterodyne tuner

Antenna:

FM lead antenna

AM loop antenna

FM tuner section:

Tuning range

Canadian model: 87.5 – 108.0 MHz (100 kHz step)

Other models: 87.5 – 108.0 MHz (50 kHz step)

Intermediate frequency: 10.7 MHz

AM tuner section:

Tuning range

Canadian and Latin American models:

530 – 1,710 kHz (with 10 kHz tuning interval)

531 – 1,710 kHz (with 9 kHz tuning interval)

European and Russian models:

531 – 1,602 kHz (with 9 kHz tuning interval)

Australian model:

531 – 1,710 kHz (with 9 kHz tuning interval)

530 – 1,710 kHz (with 10 kHz tuning interval)

Other models:

531 – 1,602 kHz (with 9 kHz tuning interval)

530 – 1,610 kHz (with 10 kHz tuning interval)

Intermediate frequency: 450 kHz

#### General

Power requirements:

Canadian model: AC 120 V, 60 Hz

Mexican model: AC 120 V, 60 Hz

European and Russian models: AC 230 V, 50/60 Hz

Australian model: AC 230 – 240 V, 50/60 Hz

Argentine model: AC 220 V, 50/60 Hz

Korean model: AC 220 V, 60 Hz

Taiwan model: AC 120 V, 50/60 Hz

Other models: AC 110 – 120 or 220 – 240 V, 50/60 Hz

Adjustable with voltage selector

Power consumption: 25 W

Dimensions (w/h/d) (excl. speakers): Approx. 155 × 241 × 224.6 mm

Mass (excl. speakers): Approx. 2.2 kg

Design and specifications are subject to change without notice.

9-889-094-01

2008D05-1

© 2008.04

**Sony Corporation**

Audio Business Group

Published by Sony Techno Create Corporation

## COMPACT DISC DECK RECEIVER

# SONY®

## Notes on chip component replacement

- Never reuse a disconnected chip component.
- Notice that the minus side of a tantalum capacitor may be damaged by heat.

### CAUTION

Use of controls or adjustments or performance of procedures other than those specified herein may result in hazardous radiation exposure.

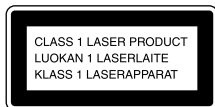

This appliance is classified as a CLASS 1 LASER product. This marking is located on the rear exterior.

## TABLE OF CONTENTS

<b>1. SERVICING NOTES</b> .....	3
<b>2. GENERAL</b> .....	4
<b>3. DISASSEMBLY</b>	
3-1. Disassembly Flow .....	6
3-2. Rear Cabinet Block .....	6
3-3. Front Cabinet Block, Top Cabinet Block, MAIN Board .....	7
3-4. MF-EH10 (Tape Mechanism Deck), Cassette Lid.....	7
3-5. Base Unit Block (BU-K8BD90-WOD) .....	8
3-6. Optical Pick-up Block (KSM-213CDP) .....	8
<b>4. TEST MODE</b> .....	9
<b>5. MECHANICAL ADJUSTMENTS</b> .....	10
<b>6. ELECTRICAL ADJUSTMENTS</b> .....	10
<b>7. DIAGRAMS</b>	
7-1. Printed Wiring Board - CD Board - .....	14
7-2. Schematic Diagram - CD Board - .....	15
7-3. Printed Wiring Board - PANEL Board - .....	16
7-4. Schematic Diagram - PANEL Board - .....	17
7-5. Schematic Diagram - MAIN Section (1/2) - .....	18
7-6. Schematic Diagram - MAIN Section (2/2) - .....	19
7-7. Printed Wiring Boards - MAIN Section - .....	20
<b>8. EXPLODED VIEWS</b>	
8-1. Overall Section .....	27
8-2. Front Cabinet Section .....	28
8-3. Top Cabinet Section .....	29
8-4. Base Unit Section (BU-K8BD90-WOD) .....	30
<b>9. ELECTRICAL PARTS LIST</b> .....	31

### SAFETY-RELATED COMPONENT WARNING!

COMPONENTS IDENTIFIED BY MARK  $\triangle$  OR DOTTED LINE WITH MARK  $\triangle$  ON THE SCHEMATIC DIAGRAMS AND IN THE PARTS LIST ARE CRITICAL TO SAFE OPERATION. REPLACE THESE COMPONENTS WITH SONY PARTS WHOSE PART NUMBERS APPEAR AS SHOWN IN THIS MANUAL OR IN SUPPLEMENTS PUBLISHED BY SONY.

### ATTENTION AU COMPOSANT AYANT RAPPORT À LA SÉCURITÉ!

LES COMPOSANTS IDENTIFIÉS PAR UNE MARQUE  $\triangle$  SUR LES DIAGRAMMES SCHÉMATIQUES ET LA LISTE DES PIÈCES SONT CRITIQUES POUR LA SÉCURITÉ DE FONCTIONNEMENT. NE REMPLACER CES COM- POSANTS QUE PAR DES PIÈCES SONY DONT LES NUMÉROS SONT DON- NÉS DANS CE MANUEL OU DANS LES SUPPLÉMENTS PUBLIÉS PAR SONY.

## SECTION 1 SERVICING NOTES

### NOTES ON HANDLING THE OPTICAL PICK-UP BLOCK OR BASE UNIT

The laser diode in the optical pick-up block may suffer electrostatic break-down because of the potential difference generated by the charged electrostatic load, etc. on clothing and the human body. During repair, pay attention to electrostatic break-down and also use the procedure in the printed matter which is included in the repair parts.

The flexible board is easily damaged and should be handled with care.

### NOTES ON LASER DIODE EMISSION CHECK

The laser beam on this model is concentrated so as to be focused on the disc reflective surface by the objective lens in the optical pickup block. Therefore, when checking the laser diode emission, observe from more than 30 cm away from the objective lens.

### UNLEADED SOLDER

Boards requiring use of unleaded solder are printed with the lead-free mark (LF) indicating the solder contains no lead.

(Caution: Some printed circuit boards may not come printed with the lead free mark due to their particular size)

### : LEAD FREE MARK

Unleaded solder has the following characteristics.

- Unleaded solder melts at a temperature about 40 °C higher than ordinary solder.  
Ordinary soldering irons can be used but the iron tip has to be applied to the solder joint for a slightly longer time.  
Soldering irons using a temperature regulator should be set to about 350 °C.  
Caution: The printed pattern (copper foil) may peel away if the heated tip is applied for too long, so be careful!
- Strong viscosity  
Unleaded solder is more viscous (sticky, less prone to flow) than ordinary solder so use caution not to let solder bridges occur such as on IC pins, etc.
- Usable with ordinary solder  
It is best to use only unleaded solder but unleaded solder may also be added to ordinary solder.

### MODEL IDENTIFICATION

#### – Rear Cabinet –

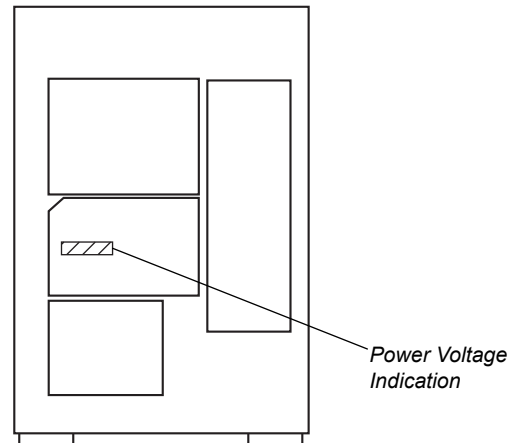

Model	POWER VOLTAGE INDICATION
Canadian and Mexican models	AC 120 V, 60 Hz
UK and Russian models	AC 230 V, 50/60 Hz
Australian model	AC 230 – 240 V, 50/60 Hz
Argentina model	AC 220 V, 50/60 Hz
Korean model	AC 220 V, 60 Hz
Taiwan model	AC 120 V, 50/60 Hz
Singapore, Chilean and Peruvian models	AC 110 – 120 or 220 – 240 V, 50/60 Hz

### LASER DIODE AND FOCUS SEARCH OPERATION CHECK

During normal operation of the equipment, emission of the laser diode is prohibited unless the upper lid is closed while turning on the SW750. (push switch type)

The following checking method for the laser diode is operable.

#### • Method

##### Emission of the laser diode is visually checked.

1. Open the upper lid.
2. Push the SW750 as shown in Fig.1.  
**Note:** Do not push the detection lever strongly, or it may be bent or damaged.
3. Check the object lens for confirming normal emission of the laser diode. If not emitting, there is a trouble in the automatic power control circuit or the optical pick-up.  
In this operation, the object lens will move up and down 2 times along with inward motion for the focus search.

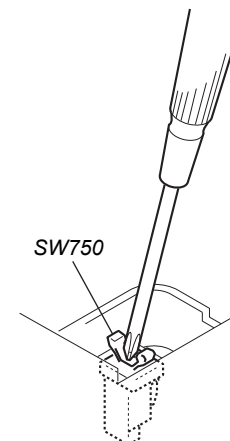

**Fig.1 Method to push the SW750**

This section is extracted from instruction manual.

**Basic Operations**

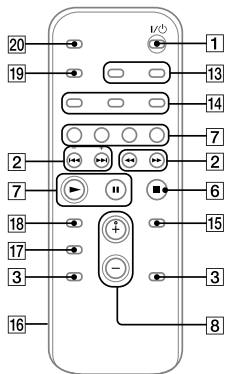
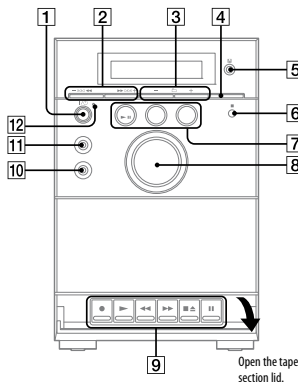

This manual mainly explains operations using the remote, but the same operations can also be performed using the buttons on the unit having the same or similar names.

**Before using the system**

**To use the remote**

Slide and remove the battery compartment lid [16], and insert the two R6 (size AA) batteries (not supplied), side first, matching the polarities shown below.

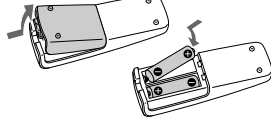

**Notes on using the remote**

- With normal use, the batteries should last for about six months.
- Do not mix an old battery with a new one or mix different types of batteries.
- If you do not use the remote for a long period of time, remove the batteries to avoid damage from battery leakage and corrosion.

**To set the clock**

Use buttons on the remote to set the clock.

- 1 Turn on the system.  
Press I/⏻ (on/standby) [1].
- 2 Select the clock set mode.  
Press CLOCK/TIMER SET [13]. If the current mode appears, press ◀▶ [2] repeatedly to select "CLOCK", and then press ENTER [15].
- 3 Set the time.  
Press ◀▶ [2] repeatedly to set the hour, and then press ENTER [15]. Use the same procedure to set the minutes.  
The clock settings are lost when you disconnect the power cord or if a power failure occurs.

**Selecting a music source**

Press the following buttons (or press FUNCTION [7] repeatedly).

To select	Press
CD	CD [7].
Tuner	TUNER/BAND [7].
Tape	FUNCTION [7] repeatedly until "TAPE" appears.
Component* (connected using an audio cord)	AUDIO IN [7].

\* If the component has the AVLS (Automatic Volume Limiter System) or BASS BOOST function, turn off the function to avoid distorted sound from the speakers.

**Adjusting the sound**

**To adjust the volume**

Press VOLUME +/- (or turn the VOLUME control on the unit) [8].

**To add a sound effect**

To	Press
Generate a more dynamic sound (Dynamic Sound Generator X-tra)	DSGX [4] on the unit.
Set the sound effect	EQ [17].

**Playing a CD/MP3 disc**

- 1 Select the CD function.  
Press CD (or FUNCTION repeatedly) [7].
- 2 Place a disc.  
Press ▲PUSH OPEN/CLOSE on the unit, and place a disc with the label side up on the CD compartment. To close the CD compartment, press ▲PUSH OPEN/CLOSE on the unit.

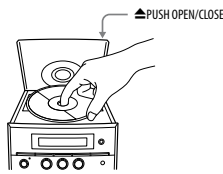

- 3 Start playback.  
Press ▶ (play) (or CD/▶|| (play/pause) on the unit) [7].

To	Press
Pause playback	(pause) (or CD/▶   on the unit) [7]. To resume play, press it again.
Stop playback	■ (stop) [6].
Select a folder on an MP3 disc	◀ +/- (select folder) [3].
Select a track or file	◀▶ (go back/go forward) (◀◀/▶▶ on the unit) [2].
Find a point in a track or file	Hold down ◀▶ (rewind/fast forward) [2] during playback, and release it at the desired point.
Select Repeat Play	REPEAT [14] repeatedly until "REP" or "REPI" appears.

**To change the play mode**

Press PLAY MODE [14] repeatedly while the player is stopped. You can select normal play ("□" for all MP3 files in the folder on the disc), shuffle play ("SHUF" or "SHUF\*"), or program play ("PGM").

\* When playing a CD-DA disc, □ (SHUF) Play performs the same operation as SHUF Play.

**Notes on Repeat Play**

- All tracks or files on a disc are played repeatedly up to five times.
- "REPI" indicates that a single track or file is repeated until you stop it.

**Notes on playing MP3 discs**

- Do not save other types of tracks or files or unnecessary folders on a disc that has MP3 files.
- Folders that have no MP3 files are skipped.
- MP3 files are played back in the order that they are recorded onto the disc.
- The system can only play MP3 files that have a file extension of ".MP3".
- If there are files on the disc that have the ".MP3" file extension, but that are not MP3 files, the unit may produce noise or may malfunction.
- The maximum number of:
  - folders is 150 (including the root folder).
  - MP3 files is 255.
  - MP3 files and folders that can be contained on a single disc is 256.
  - folder levels (the tree structure of files) is 8.
- Compatibility with all MP3 encoding/writing software, recording device, and recording media cannot be guaranteed. Incompatible MP3 discs may produce noise or interrupted audio or may not play at all.

**Notes on playing multisession discs**

- If the disc begins with a CD-DA (or MP3) session, it is recognized as a CD-DA (or MP3) disc, and playback continues until another session is encountered.
- A disc with a mixed CD format is recognized as a CD-DA (audio) disc.

**Listening to the radio**

- 1 Select "FM" or "AM."  
Press TUNER/BAND [7] repeatedly.
- 2 Select the tuning mode.  
Press TUNING MODE [14] repeatedly until "AUTO" appears.
- 3 Tune in the desired station.  
Press +/- (or TUNING +/- on the unit) [2]. Scanning stops automatically when a station is tuned in. When you tune in a station that provides RDS services, the station name appears.

**Tip**  
To stop automatic scanning, press ■ (stop) [6].

**To tune in a station with a weak signal**

Press TUNING MODE [14] repeatedly until "MANUAL" appears, and then press +/- (or TUNING +/- on the unit) [2] repeatedly to tune in the desired station.

**To reduce static noise on a weak FM stereo station**

Press FM MODE [14] repeatedly until "MONO" appears to turn off stereo reception.

**Playing a tape**

Use buttons on the unit to play a tape.

- 1 Select the tape function.  
Press FUNCTION [7] repeatedly.
- 2 Insert a tape.  
Press ■▲ (stop/eject) [9], and insert the tape into the cassette holder. Make sure there is no slack in the tape to avoid damaging the tape or the tape deck.
- 3 Start playback.  
Press ▶ (play) [9].

To	Press
Pause playback	(pause) [9]. To resume play, press it again.
Stop playback	■▲ (stop/eject) [9].
Rewind or fast forward*	◀▶ (rewind/fast forward) [9].

\* Be sure to press ■▲ (stop/eject) [9] after the tape has been wound or rewound to the end.

**Note**  
Do not turn off the system during playback or recording.

**Changing the display**

To change	Press
Information on the display <sup>1)</sup>	DISPLAY [19] repeatedly when the system is on.
Display mode (Clock)	DISPLAY [19] when the system is off <sup>2)</sup> . The clock is displayed for eight seconds.

<sup>1)</sup> For example, you can view CD/MP3 disc information, such as the track or file number or folder name during normal play, or the total play time while the player is stopped.  
<sup>2)</sup> The STANDBY indicator [12] lights up when the system is turned off.

**Notes on the display information**

- The following are not displayed.
  - total playing time for a CD-DA disc depending on the play mode.
  - total playing time for an MP3 disc.
  - remaining playing time for a track and an MP3 file.
- The following are not displayed correctly:
  - elapsed playing time of an MP3 file encoded using VBR (variable bit rate).
  - folder and file names that do not follow either ISO9660 Level 1, Level 2 or Joliet in the expansion format.
- The following are displayed:
  - ID3 tag information for MP3 files when ID3 version 1 and version 2 tags are used.
  - up to 15 characters of ID3 tag information using uppercase letters (A to Z), numbers (0 to 9), and symbols (< > \* + - / @ [ \ ] \_).

**Using optional audio components**

**To connect an optional headphones**

Connect headphones to the PHONES jack [10] on the unit.

**To connect an optional component**

Connect additional audio source component to the AUDIO IN jack [11] on the unit using an audio analog cord (not supplied). Turn down the volume on the system, and then select the AUDIO IN function.

## Other Operations

### Creating your own CD program (Program Play)

Use buttons on the remote to create your own program.

- 1 Press CD [7] to select the CD function.
- 2 Press PLAY MODE [14] repeatedly until "PGM" appears while the player is stopped.
- 3 Press [◀▶] [2] repeatedly until the desired track number appears.  
When programming MP3 files, press [◻] +/- [3] repeatedly to select the desired folder, and then select the desired file.

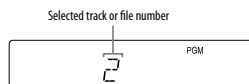

- 4 Press ENTER [15] to add the track or file to the program.
- 5 Repeat steps 3 through 4 to program additional tracks or files, up to a total of 15 tracks or files.
- 6 To play your program of tracks or files, press ▶ [7].  
The program remains available until you open the CD compartment. To play it again, select the CD function, and then press ▶ [7].

To cancel Program Play, press PLAY MODE [14] repeatedly until "PGM" disappears while the player is stopped.

To delete the last track or file of the program, press CLEAR [18] while the player is stopped.

To view program information, such as total track number of the program, press DISPLAY [19] repeatedly.

### Presetting radio stations

You can preset your favorite radio stations and tune them in instantly by selecting the corresponding preset number.

Use buttons on the remote to preset stations.

- 1 Press TUNER/BAND [7] repeatedly to select "FM" or "AM."
- 2 Press TUNING MODE [14] repeatedly until "AUTO" appears (or "MANUAL" appears, for a station with a weak signal).
- 3 Press +/- [2] to tune in the desired station.  
Scanning stops automatically when a station is tuned in, and then "TUNED" and "STEREO" (for stereo programs) appear.

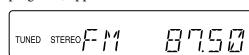

If "TUNED" does not appear and the scanning does not stop, press TUNING MODE [14] until "MANUAL" appears, and then press +/- [2] repeatedly to tune in the desired station.

- 4 Press TUNER MEMORY [14].

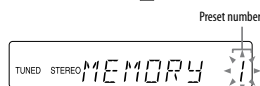

- 5 Press +/- [2] repeatedly to select your desired preset number.  
If another station is already assigned to the selected preset number, the station is replaced by the new stations.
- 6 Press ENTER [15].
- 7 Repeat steps 1 through 6 to store other stations.  
You can preset up to 20 FM and 10 AM stations. The preset stations are retained for about half a day even if you disconnect the power cord or if a power failure occurs.
- 8 To call up a preset radio station, press TUNING MODE [14] repeatedly until "PRESET" appears, and then press +/- [2] repeatedly to select the desired preset number.

To change the AM tuning interval from the factory preset to 9 kHz (or 10 kHz, for some areas; this function is not available on European and Russian model), tune in any AM station, and then turn off the system. Press DISPLAY [19] to display the clock, and while hold down TUNING + [2] on the unit, press I/O [1] on the unit. All the AM preset stations are erased. To reset the interval to the factory preset, repeat the procedure.

### Recording onto a tape

Use a TYPE I (normal) tape only.

You can record just the portions you like from a sound source, including connected audio components.

Use buttons on the unit to control tape recording.

- 1 Insert a recordable tape into the cassette holder with the side you want to record facing forward.
- 2 Prepare the recording source.  
Select the desired source to record.  
Place the disc you want to record.  
When recording a folder from an MP3 disc, press PLAY MODE [14] on the remote repeatedly to select "◻", and then press [◻] +/- [3] repeatedly to select the desired folder.  
To record only your favorite CD tracks or MP3 files in your desired order, perform steps 2 to 5 of "Creating your own CD program."

- 3 Start recording.  
Press ● (record) [9], and then start playing the desired recording source.  
The CD starts playing automatically.  
If there is noise while recording from the tuner, reposition the appropriate antenna to reduce the noise.  
While recording, you cannot listen to other sources.

To stop recording, press ■▲ [9].

**Tip**  
We recommend that you press ■ [9] first, and then press ■▲ [9] to avoid noise being recorded when you stop recording.

### Using the Timers

The system offers two timer functions. If you use both timers, the Sleep Timer has priority.

Use buttons on the remote to use the timer functions.

#### Sleep Timer:

You can fall asleep to music. This function works even if the clock is not set.  
Press SLEEP [20] repeatedly. If you select "AUTO," the system automatically turns off after the current disc or tape stops or in 100 minutes.  
If the tape deck is still playing or recording at the set time, the system turns off after the tape deck stops.

#### Play Timer:

You can wake up to CD or tuner at a preset time.

Make sure you have set the clock.

- 1 Prepare the sound source.  
Prepare the sound source, and then press VOLUME +/- [8] to adjust the volume.  
To start from a specific CD track or MP3 file, create your own CD program.
- 2 Press CLOCK/TIMER SET [13].
- 3 Press [◀▶] [2] repeatedly to select "PLAY SET" and then press ENTER [15].  
"ON TIME" appears, and the hour indication flashes.
- 4 Set the time to start playing.  
Press [◀▶] [2] repeatedly to set the hour, and then press ENTER [15].  
The minute indication flashes. Use the procedure above to set the minutes.
- 5 Use the same procedure as in step 4 to set the time to stop playing.
- 6 Select the sound source.  
Press [◀▶] [2] repeatedly until the desired sound source appears, and then press ENTER [15]. The display shows the timer settings.
- 7 Press I/O [1] to turn off the system.  
The system turns on 15 seconds before the preset time. If the system is on at the preset time, the Play Timer will not play.

To activate or check the timer again, press CLOCK/TIMER SELECT [13], press [◀▶] [2] repeatedly until "PLAY SEL" appears, and then press ENTER [15].

To cancel a timer, repeat the same procedure as above until "OFF" appears, and then press ENTER [15].

To change the setting, start over from step 1.

**Tip**  
The Play Timer setting remains as long as the setting is not canceled manually.

## SECTION 3 DISASSEMBLY

- This set can be disassembled in the order shown below.

### 3-1. DISASSEMBLY FLOW

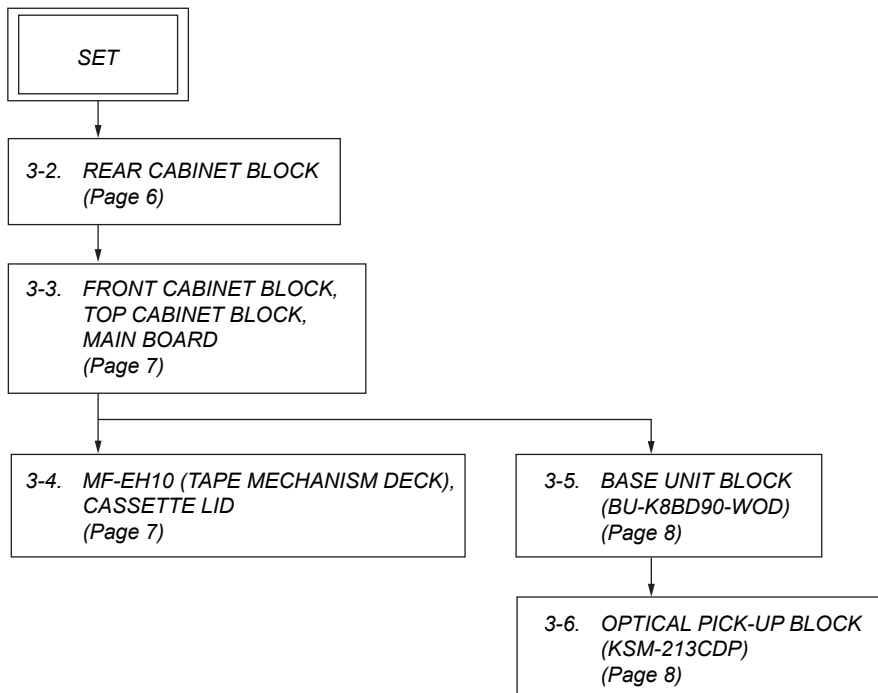

**Note:** Follow the disassembly procedure in the numerical order given.

### 3-2. REAR CABINET BLOCK

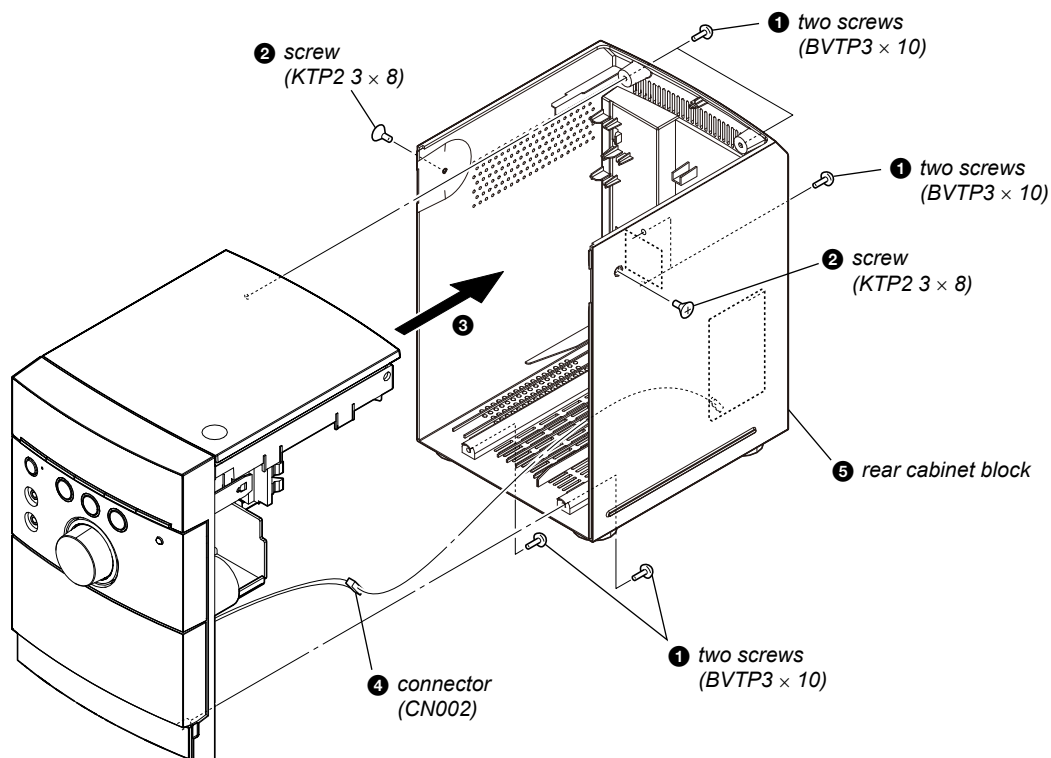

3-3. FRONT CABINET BLOCK, TOP CABINET BLOCK, MAIN BOARD

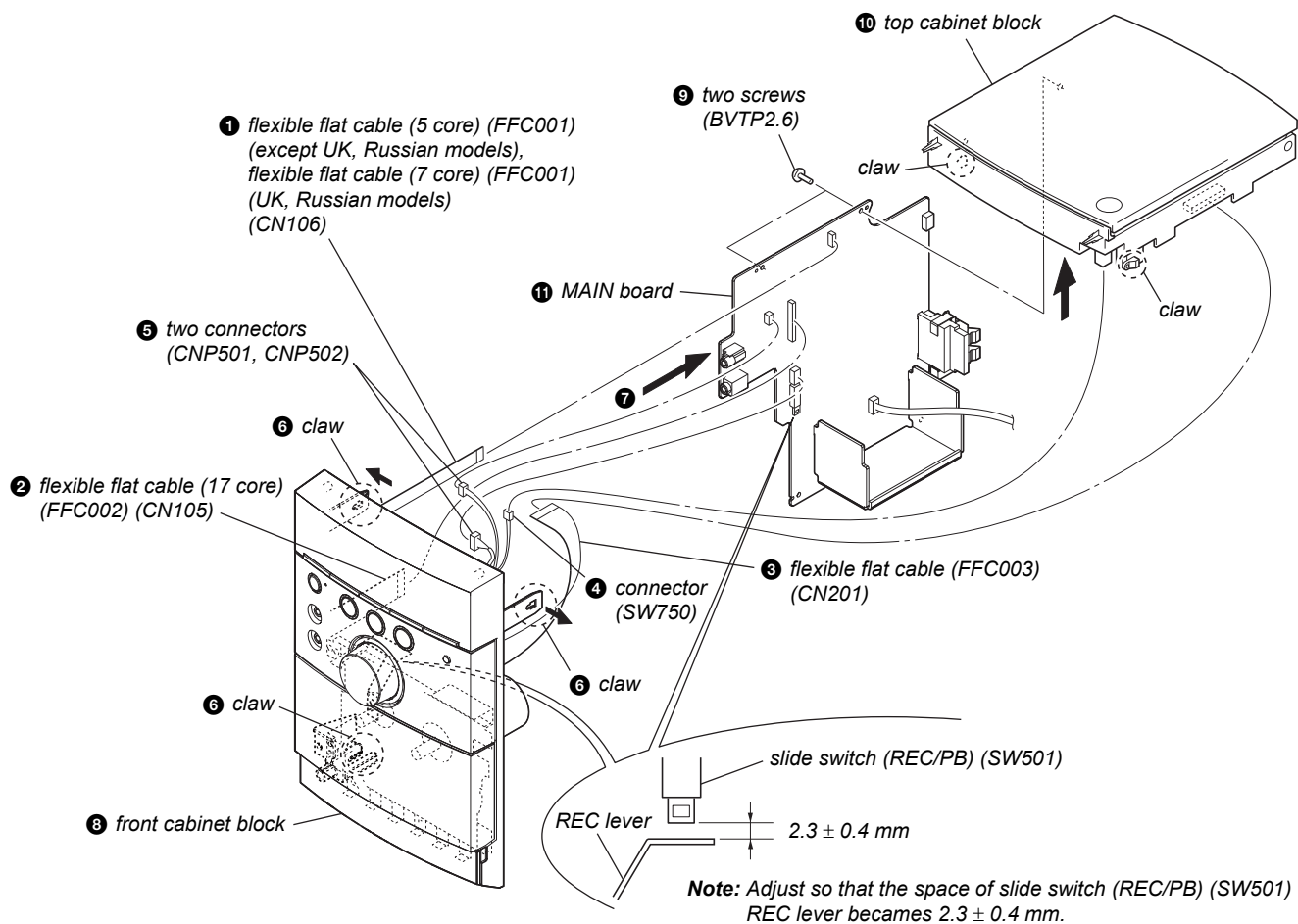

3-4. MF-EH10 (TAPE MECHANISM DECK), CASSETTE LID

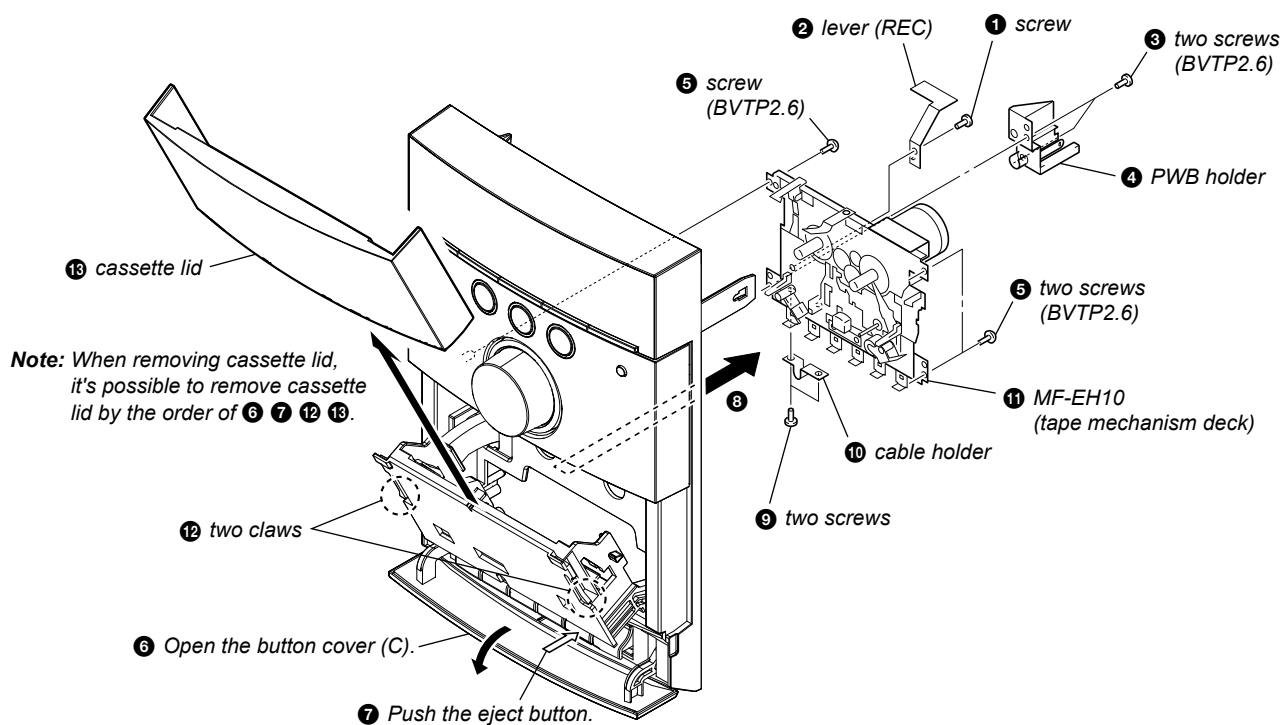

## 3-5. BASE UNIT BLOCK (BU-K8BD90-WOD)

*Note: This illustration sees the top cabinet block back side from back.*

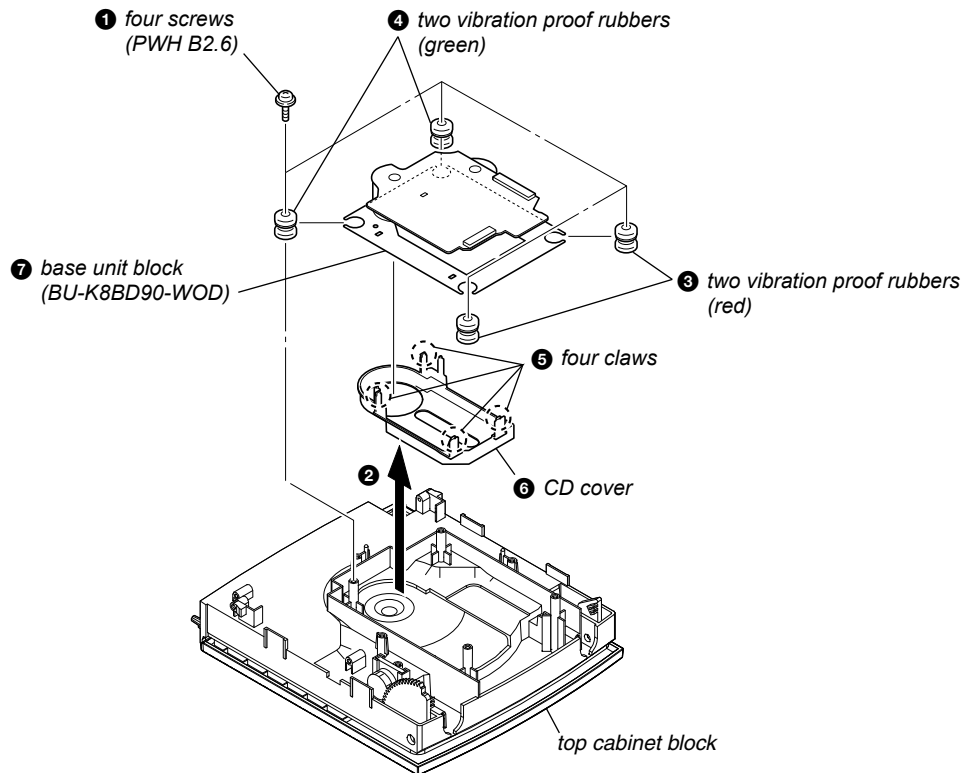

## 3-6. OPTICAL PICK-UP BLOCK (KSM-213CDP)

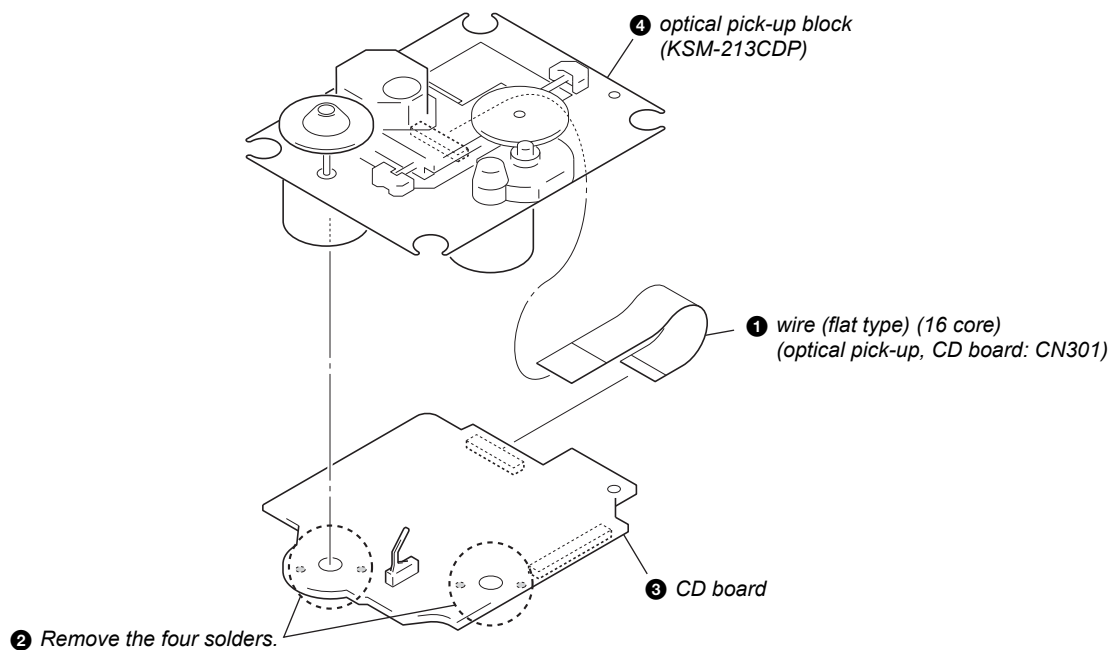



## SECTION 4 TEST MODE

### COLD RESET

The cold reset clears all data including preset data stored in the memory to initial conditions. Execute this mode when returning the set to the customer.

#### Procedure:

1. Press three buttons of [■], [⏪ ⏩ – TUNING] and [I/⏻] simultaneously.
2. When “RESET” appears, the set enters standby status.

### PANEL TEST

#### Procedure:

1. Press the [I/⏻] button to turn the power on.
2. Press three buttons of [FUNCTION], [TUNER/BAND], and [I/⏻] simultaneously.
3. When the panel test is activated, [STANDBY] LED and segments on the liquid crystal display are all turned on.
4. Press the [CD ▶▶] button, date and version are displayed. For example, “1115V002”.
5. Press the [TUNER/BAND] button, model name and destination are displayed. For example, “EH15ASIA”.
6. To release from this mode, press three buttons of [FUNCTION], [TUNER/BAND], and [I/⏻] simultaneously.

### TUNER STEP CHANGE

#### (Except UK and Russian models)

The AM tuning interval can be changed over 9 kHz or 10 kHz.

#### Procedure:

1. Press the [I/⏻] button to turn the power on.
2. Press the [TUNER/BAND] button to select TUNER (AM) function.
3. Press the [I/⏻] button again to turn the power off (standby).
4. After pressing the [DISPLAY] button on the remote commander, while pressing the [TUNING + ▶▶ ▷▷] button, press the [I/⏻] button.
5. It turns power on and display “9K STEP” or “10K STEP”, and thus the tuning interval is changed over.

### CD SERVICE MODE

This mode can move the SLED of the optical pick-up, and also can turn the optical pick-up laser power on and off.

#### Procedure:

1. Press the [I/⏻] button to turn the power on.
2. Press the [FUNCTION] button to select CD function.
3. Press three buttons of [⏪ ⏩ – TUNING], [FUNCTION], and [I/⏻] simultaneously.
4. It enters the CD service mode and displays “SERVICE”.
5. To release from this mode, press three buttons of [⏪ ⏩ – TUNING], [FUNCTION] and [I/⏻] simultaneously.

#### Key Operation:

[TUNING + ▶▶ ▷▷], [⏪ ⏩ – TUNING]:

Use these keys to move the SLED. When [TUNING + ▶▶ ▷▷] is pressed in this mode, the SLED moves to outer circumference and the message “SLED OUT” is displayed.

When [⏪ ⏩ – TUNING] is pressed in this mode, the SLED moves to inner circumference and the message “SLED IN” is displayed.

[FUNCTION]:

Use this key to turn the optical pick-up laser power on and off. When the laser power is turned on, the message “LD ON” is displayed. When the laser power is turned off, the message “LD OFF” is displayed.

### CD ERROR CODE

The past errors of the optical pick-up system (= optical unit + CD board) are displayed as the BD Errors as shown below.

#### Procedure:

1. Press the [I/⏻] button to turn the power on.
2. Press the [FUNCTION] button to select CD function.
3. Press three buttons of [⏪ ⏩ – TUNING], [DSGX] and [I/⏻] simultaneously.
4. Then, the BD error code is displayed as “D0xxxxxx” (x means hexadecimal number) on the liquid crystal display as shown below.
5. Every pressing of the [TUNING + ▶▶ ▷▷] button in this mode increments the number after “D” starting from “D0” up to “D4”, and then returns to “D0”. Every pressing of the [⏪ ⏩ – TUNING] button in this mode decrements the number after “D”. The smaller the error code number is, the newer the error content is.
6. To release from this mode, press the [I/⏻] button to turn the power off.

#### Contents of “BD Errors”

Error display example

D 0 01 06 01  
① ② ③ ④

- ① It indicates the error history number  
0 to 4: The error code number 0 indicates the newest error.
- ② It indicates the error content  
01: The focus servo cannot lock-in.  
02: GFS is no good (NG).  
03: The startup time exceeds the specified period of time (time over)  
04: The focus servo is unlocked continuously.  
05: Q code cannot be obtained within the specified period of time.  
06: The tracking servo cannot lock-in.  
07: Blank disc
- ③ It indicates the on-going processing of optical pick-up system (= optical unit + CD board) when the trouble has occurred.  
01: The CD SHIP mode processing is in progress.  
02: The POWER OFF processing is in progress.  
03: The POWER ON processing is in progress.  
04: The INITIALIZE processing is in progress.  
05: The optical pick-up system (= optical unit + CD board) is in the stop state.  
06: The STOP operation is in progress.  
07: The startup processing is in progress.  
08: The TOC read-in processing is in progress.  
09: The SEARCH operation is in progress.  
0A: The PLAY operation is in progress.  
0B: The PAUSE operation is in progress.  
0C: The PLAY – MANUAL SEARCH operation is in progress.  
0D: The PAUSE – MANUAL SEARCH operation is in progress.
- ④ It indicates the operation that is being processed when the trouble has occurred.  
It indicates the step number of each processing specified by ③. Because the numbers of steps are different in each processing, this number is different in each processing.

## SECTION 5 MECHANICAL ADJUSTMENTS

### PRECAUTION

- Clean the following parts with a denatured-alcohol-moistened swab:
 

record/playback head	pinch roller
erase head	rubber belts
capstan	idlers
- Demagnetize the record/playback head with a head demagnetizer. (Do not bring the head magnetizer close to the erase head.)
- Do not use a magnetized screwdriver for the adjustments.
- After the adjustments, apply suitable locking compound to the parts adjusted.
- The adjustments should be performed with the rated power supply voltage unless otherwise noted.

### TORQUE MEASUREMENT

Mode	Torque meter	Meter reading
FWD	CQ-102AS	2.0 – 8.0 mN · m (20 – 80 g · cm) (0.28 – 1.12 oz · inch)
FWD Back Tension	CQ-102C	0.15 – 0.6 mN · m (1.5 – 6.0 g · cm) (0.021 – 0.083 oz · inch)
FF	CQ-201AS	5.0 – 17.7 mN · m (50 – 177 g · cm) (0.7 – 2.48 oz · inch)
REW	CQ-201B	5.0 – 17.7 mN · m (50 – 177 g · cm) (0.7 – 2.48 oz · inch)

### TAPE TENSION MEASUREMENT

Mode	Torque meter	Meter reading
FWD	CQ-403A	more than 80 g (more than 2.82 oz)

## SECTION 6 ELECTRICAL ADJUSTMENTS

**DECK SECTION**    0 dB=0.775 V

- Demagnetize the record/playback head with a head demagnetizer.
- Do not use a magnetized screwdriver for the adjustments.

### TEST TAPE

Tape	Signal	Used for
P-4-A063	6.3 kHz, -10 dB	Azimuth Adjustment

### RECORD/PLAYBACK HEAD AZIMUTH ADJUSTMENT

#### Procedure:

- Mode: Playback

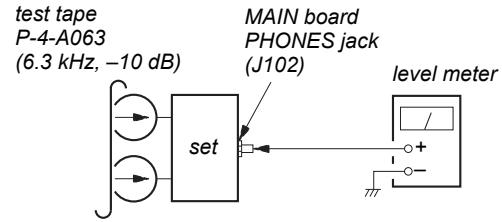

- Turn the adjustment screw and check output peaks. If the peaks do not match for L-CH and R-CH, turn the adjustment screw so that outputs match within 1dB of peak.

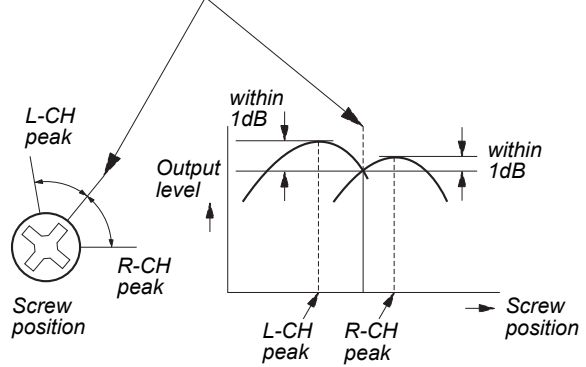

- Mode: Playback

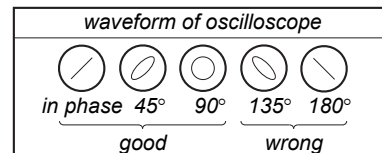
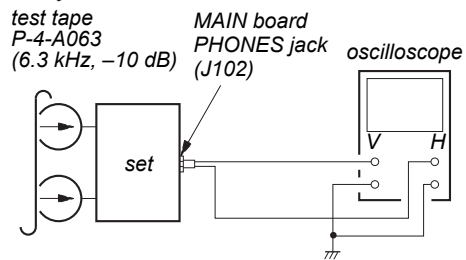

- After the adjustments, apply suitable locking compound to the parts adjusted.

**Adjustment Location:** Record/Playback/Erase Head

**Note:** Remove the cassette lid before this adjustment.  
Refer to "DISASSEMBLY" (page 6)

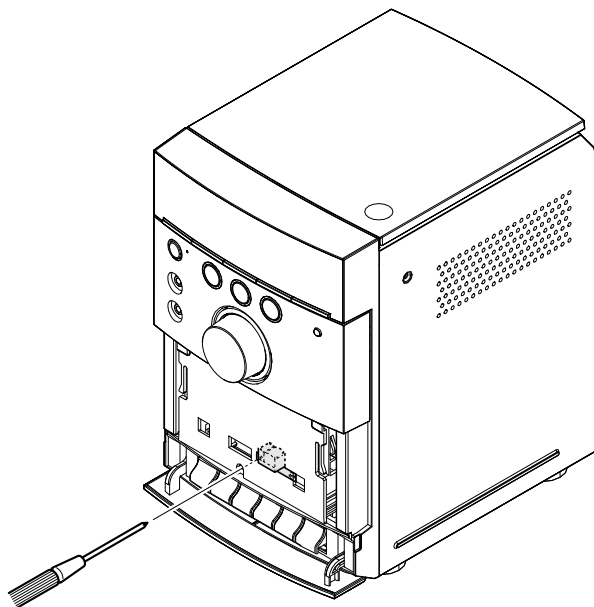

**TUNER SECTION**

0 dB=1 μV

**[AM]**

**Setting:**

Function: TUNER

Band: AM

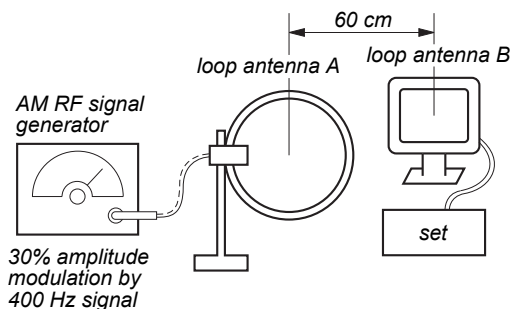

**[FM]**

**Setting:**

Function: TUNER

Band: FM

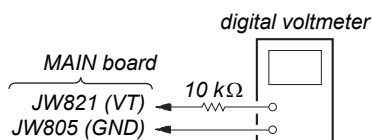
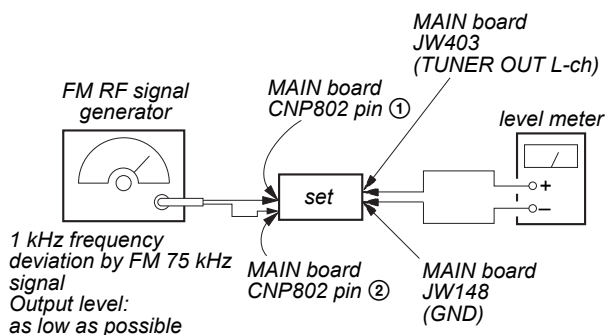

- Repeat the procedures in each adjustment several times, and the tracking adjustments should be finally done by the trimmer capacitors.
- Remove FM antenna in FM adjustment.

( ): UK and Russian models

AM VT VOLTAGE ADJUSTMENT		
Adjustment Part	Frequency Display	Reading on Digital Voltmeter
L852	530 (531) kHz	1.5 ± 0.1 V
Confirmation	1710 (1602) kHz	8.0 (7.2) ± 0.5 V

( ): UK and Russian models

AM TRACKING ADJUSTMENT	
Adjust for a maximum reading on level meter	
L851	530 (531) kHz

FM VT VOLTAGE ADJUSTMENT		
Adjustment Part	Frequency Display	Reading on Digital Voltmeter
L805	87.5 MHz	1.75 ± 0.1 V
Confirmation	108 MHz	6.2 ± 0.5 V

FM TRACKING ADJUSTMENT	
Adjust for a maximum reading on level meter	
L804	98 MHz

**FM DETECTOR ADJUSTMENT**

**Setting:**

Function: TUNER

BAND button: FM

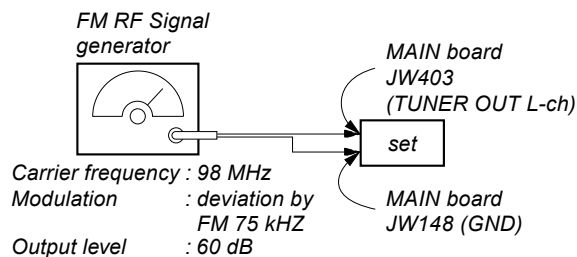

1. Tune the set to 98 MHz.
2. Adjust L806 so that modulation distortion may become the best in the vicinity of the maximum value where the tuner out level becomes -156Bs or more.

## Adjustment Location:

### - MAIN Board (Component Side) -

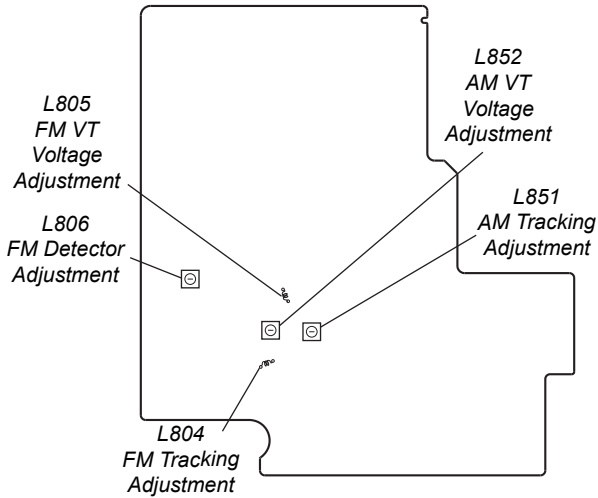

### - MAIN Board (Conductor Side) -

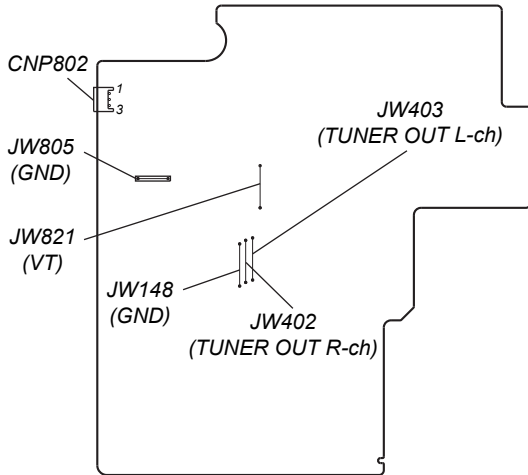

## FM TUNE LEVEL CHECK

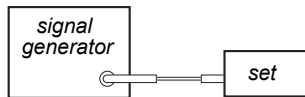

### Procedure:

1. Turn on the set.
2. Input the following signal from signal generator to FM antenna input directly.

Carrier frequency : A = 87.5 MHz, B = 98 MHz, C = 108 MHz  
 Deviation : 75 kHz  
 Modulation : 1 kHz  
 ANT input : 35 dBu (EMF)

**Note:** Use 75 ohm coaxial cable to connect signal generator and the set.  
 You cannot use video cable for checking.  
 Use signal generator whose output impedance is 75 ohm.

3. Set to FM tuner function and tune A, B and C signals.
4. Confirm "TUNED" is lit on the display for A, B and C signals.

When the selected station signal is received in good condition, "TUNED" is displayed.

## CD SECTION

### Note:

1. CD Block is basically constructed to operate without adjustment.
2. Use YEDS-18 disc (3-702-101-01) unless otherwise indicated.
3. Use an oscilloscope with more than 10 MΩ impedance.
4. Clean the object lens by an applicator with neutral detergent when the signal level is low than specified value with the following checks.
5. Check the focus bias check when optical pick-up block is replaced.

## FOCUS BIAS CHECK

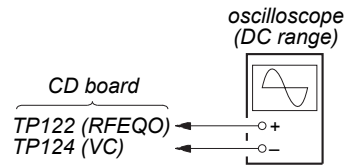

### Procedure:

1. Connect oscilloscope to TP122 (RFEQO) and TP124 (VC) on the CD board.
2. Press the [I/⏻] button to turn the power on.
3. Set the disc (YEDS-18) and press the [CD ▶||] button to playback.
4. Confirm that oscilloscope waveform is as shown in the figure below. (eye pattern)

A good eye pattern means that the diamond shape (◇) in the center of the waveform can be clearly distinguished.

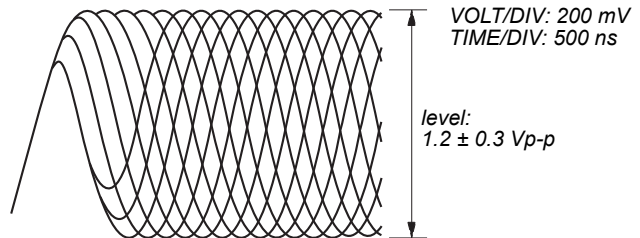

## Checking Location:

### - CD Board (Conductor Side) -

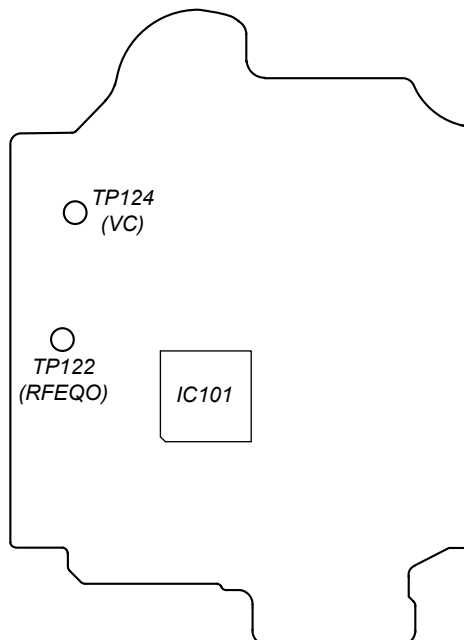

## SECTION 7 DIAGRAMS

**THIS NOTE IS COMMON FOR PRINTED WIRING BOARDS AND SCHEMATIC DIAGRAMS.**  
(In addition to this, the necessary note is printed in each block.)

### For Printed Wiring Boards.

**Note:**

- : Parts extracted from the component side.
- : parts extracted from the conductor side.
- : indicates side identified with part number.
- △: internal component.
- : Pattern from the side which enables seeing.  
(The other layers' patterns are not indicated.)

**Caution:**

Pattern face side: Parts on the pattern face side seen from (Conductor Side) the pattern face are indicated.  
Parts face side: Parts on the parts face side seen from (Component Side) the parts face are indicated.

- Indication of transistor.

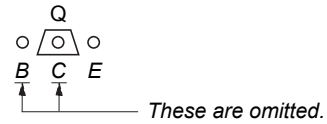
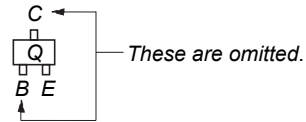

### For Schematic Diagrams.

**Note:**

- All capacitors are in  $\mu\text{F}$  unless otherwise noted. (p: pF) 50 WV or less are not indicated except for electrolytics and tantalums.
- All resistors are in  $\Omega$  and 1/4 W or less unless otherwise specified.
- △: internal component.
- : panel designation.

**Note:**

The components identified by mark △ or dotted line with mark △ are critical for safety. Replace only with part number specified.

**Note:**

Les composants identifiés par une marque △ sont critiques pour la sécurité. Ne les remplacer que par une pièce portant le numéro spécifié.

- : B+ Line.
- : adjustment for repair.
- Voltages and waveforms are dc with respect to ground under no-signal (detuned) conditions.
  - CD Board —
  - no mark: CD PLAY
  - Other Section —
  - no mark: FM
  - [ ]: AM
  - ( ): CD PLAY
  - < >: TAPE PLAY
  - { } : REC
- Voltages are taken with VOM (Input impedance 10 M $\Omega$ ). Voltage variations may be noted due to normal production tolerances.
- Waveforms are taken with a oscilloscope. Voltage variations may be noted due to normal production tolerances.
- Circled numbers refer to waveforms.
- Signal path.
  - : FM
  - : AM
  - ⇒: CD PLAY
  - ⇒: TAPE PLAY
  - ⇒: REC
  - ⇒: AUDIO IN
- Abbreviation
  - AR : Argentina model
  - AUS : Australian model
  - CND : Canadian model
  - E51 : Chilean and Peruvian model
  - KR : Korean model
  - MX : Mexican model
  - RU : Russian model
  - SP : Singapore model
  - TW : Taiwan model

### • Circuit Board Location

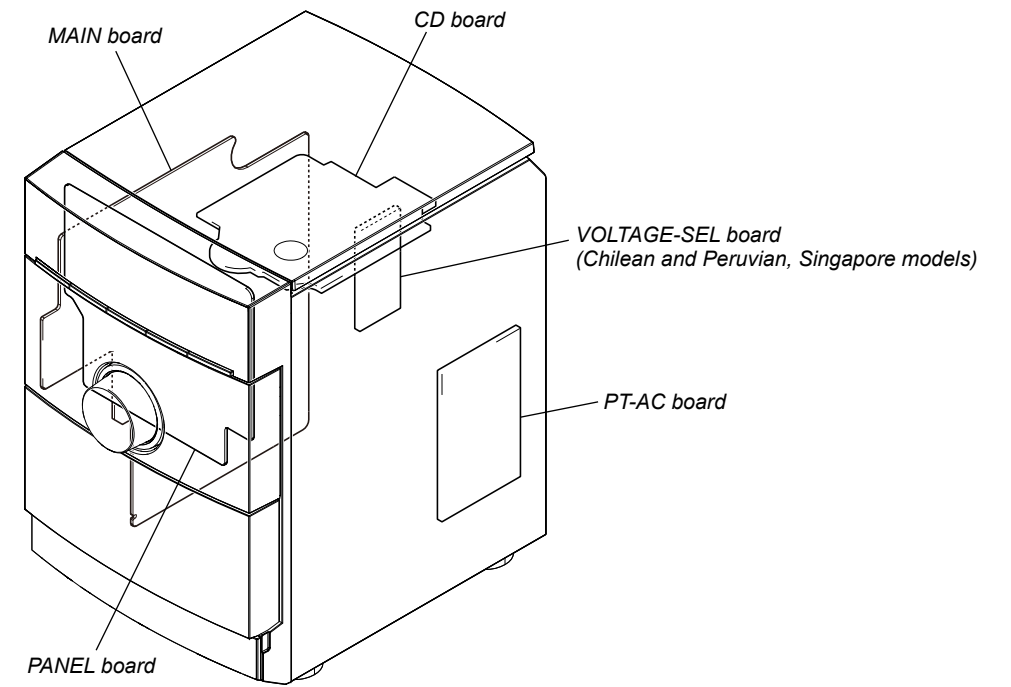

### • Waveforms — CD Board —

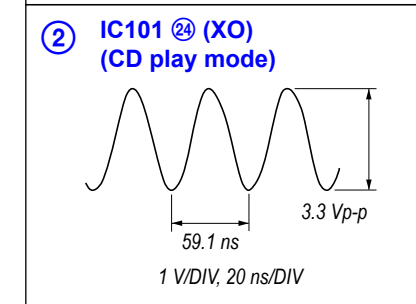
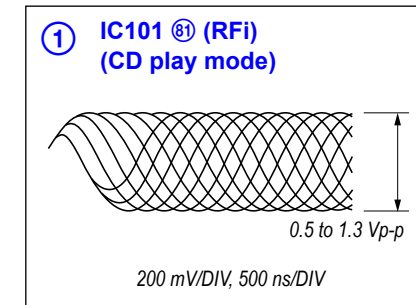

### — MAIN Board —

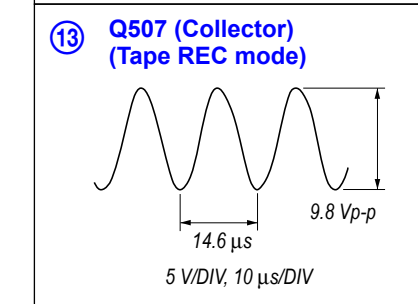
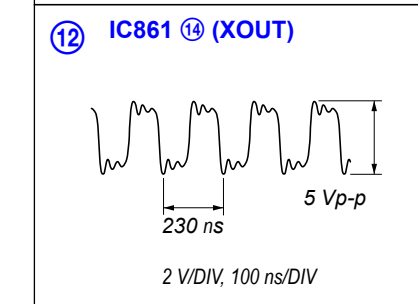
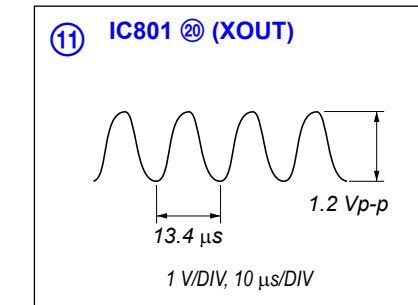

### — PANEL Board —

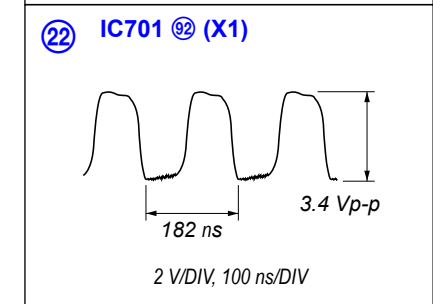
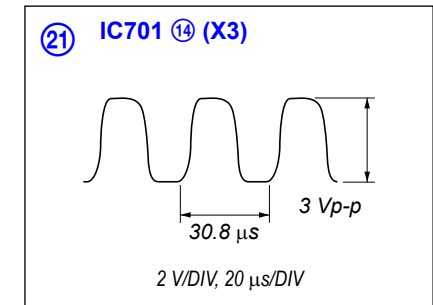

7-1. PRINTED WIRING BOARD - CD Board - • See page 13 for Circuit Boards Location. •  : Uses unleaded solder.

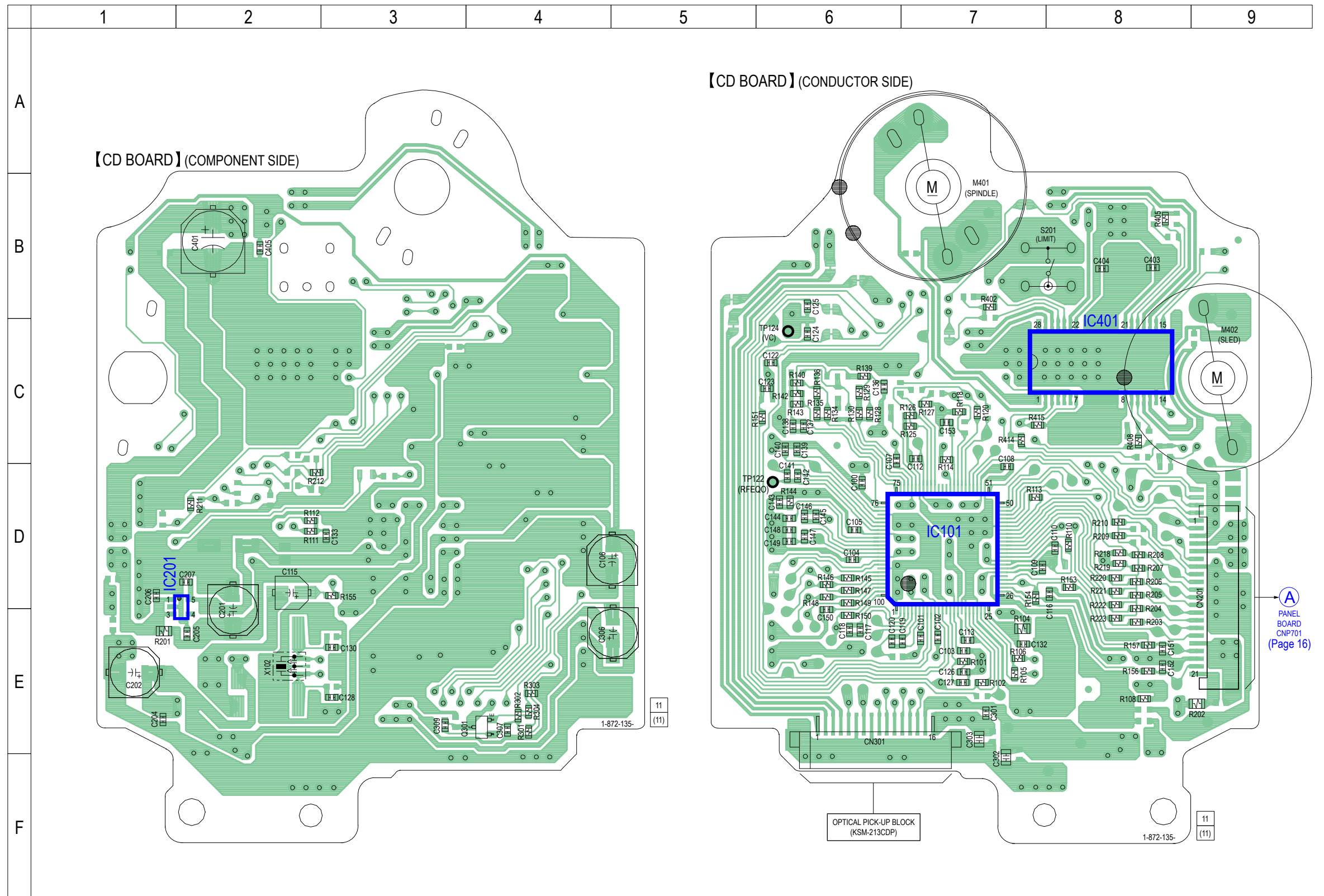

7-2. SCHEMATIC DIAGRAM - CD Board - See page 13 for Waveforms. See Page 21 for IC Block Diagrams. See Page 24 for IC Pin Function Description.

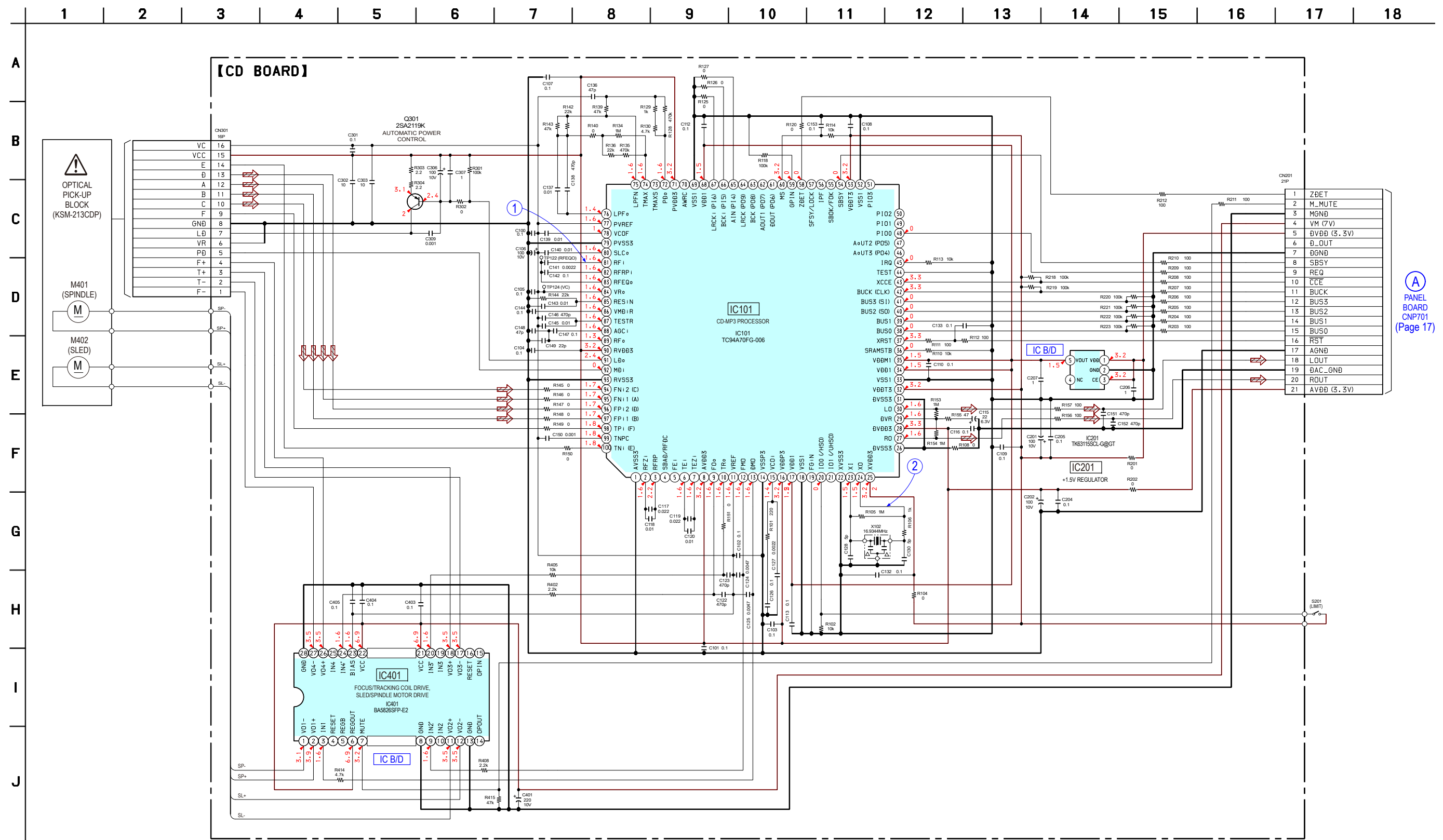

PANEL BOARD CNP701 (Page 17)

7-3. PRINTED WIRING BOARD - PANEL Board - • See page 13 for Circuit Boards Location. •  : Uses unleaded solder.

• Semiconductor Location

Ref. No.	Location
D701	B-7
D702	B-7
D801	G-2
D804	F-2
IC701	C-4
IC703	C-2
LED701	B-2
LED702	D-8
Q701	B-7
Q702	C-8
Q703	C-7
Q704	C-7
Q705	C-7
Q706	C-7
Q707	B-2
Q713	C-6
Q714	C-6

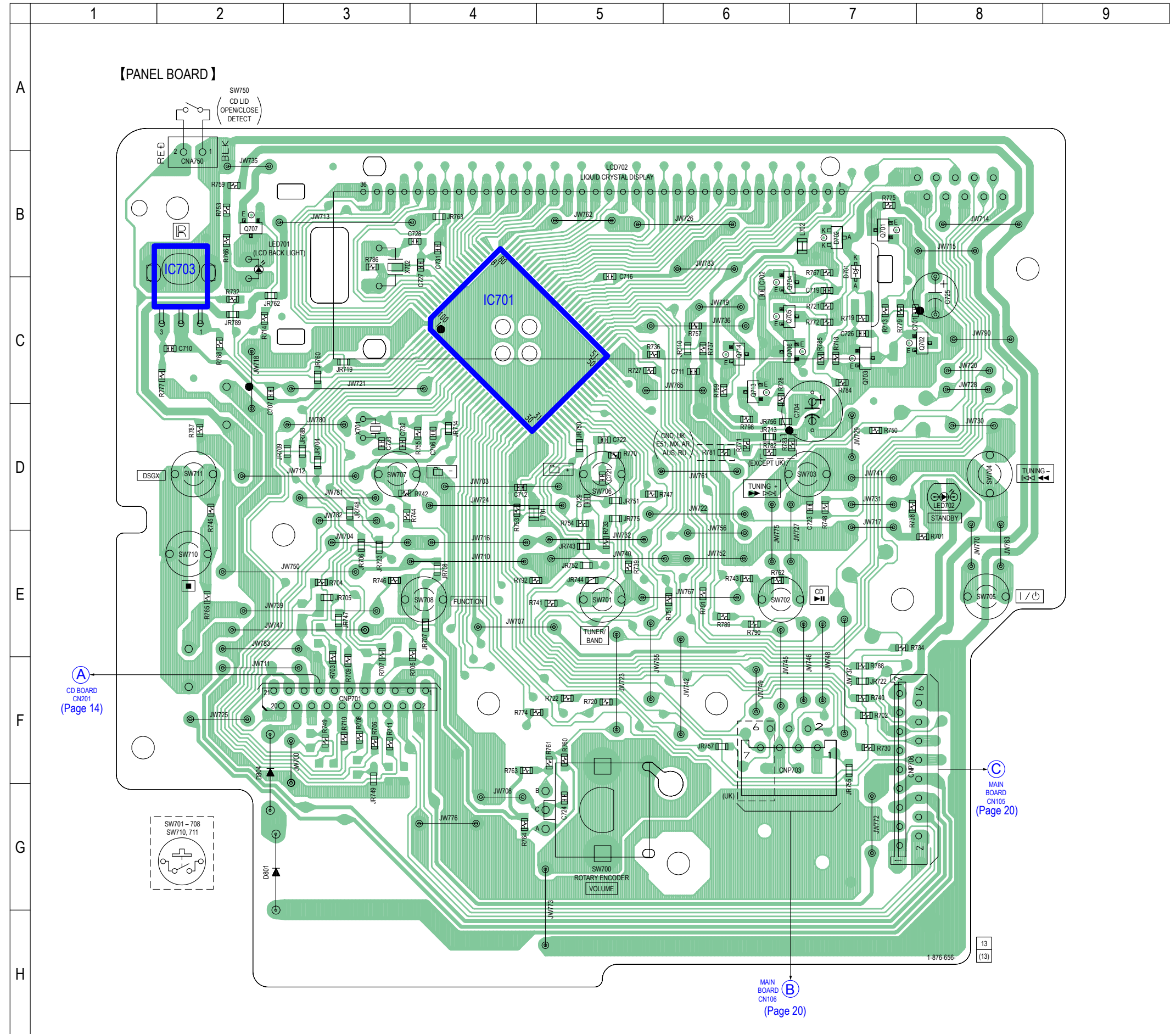



7-4. SCHEMATIC DIAGRAM - PANEL Board - • See page 13 for Waveforms. • See Page 24 for IC Pin Function Description.

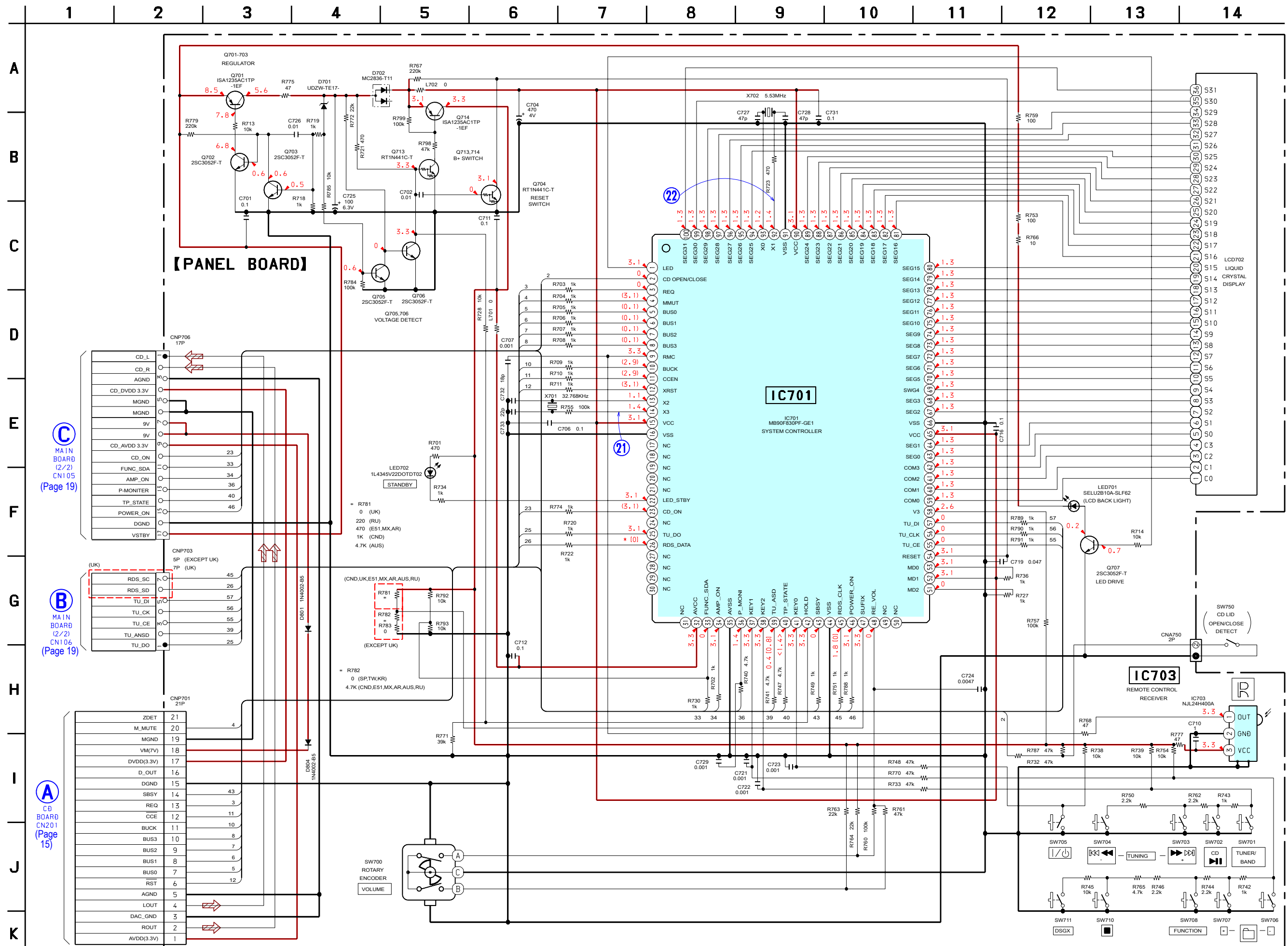

**C** MAIN BOARD (2/2) CN105 (Page 19)

**B** MAIN BOARD (2/2) CN106 (Page 19)

**A** CD BOARD CN201 (Page 15)

7-5. SCHEMATIC DIAGRAM - MAIN Section (1/2) - • See page 13 for Waveforms. • See Page 21 for IC Block Diagrams.

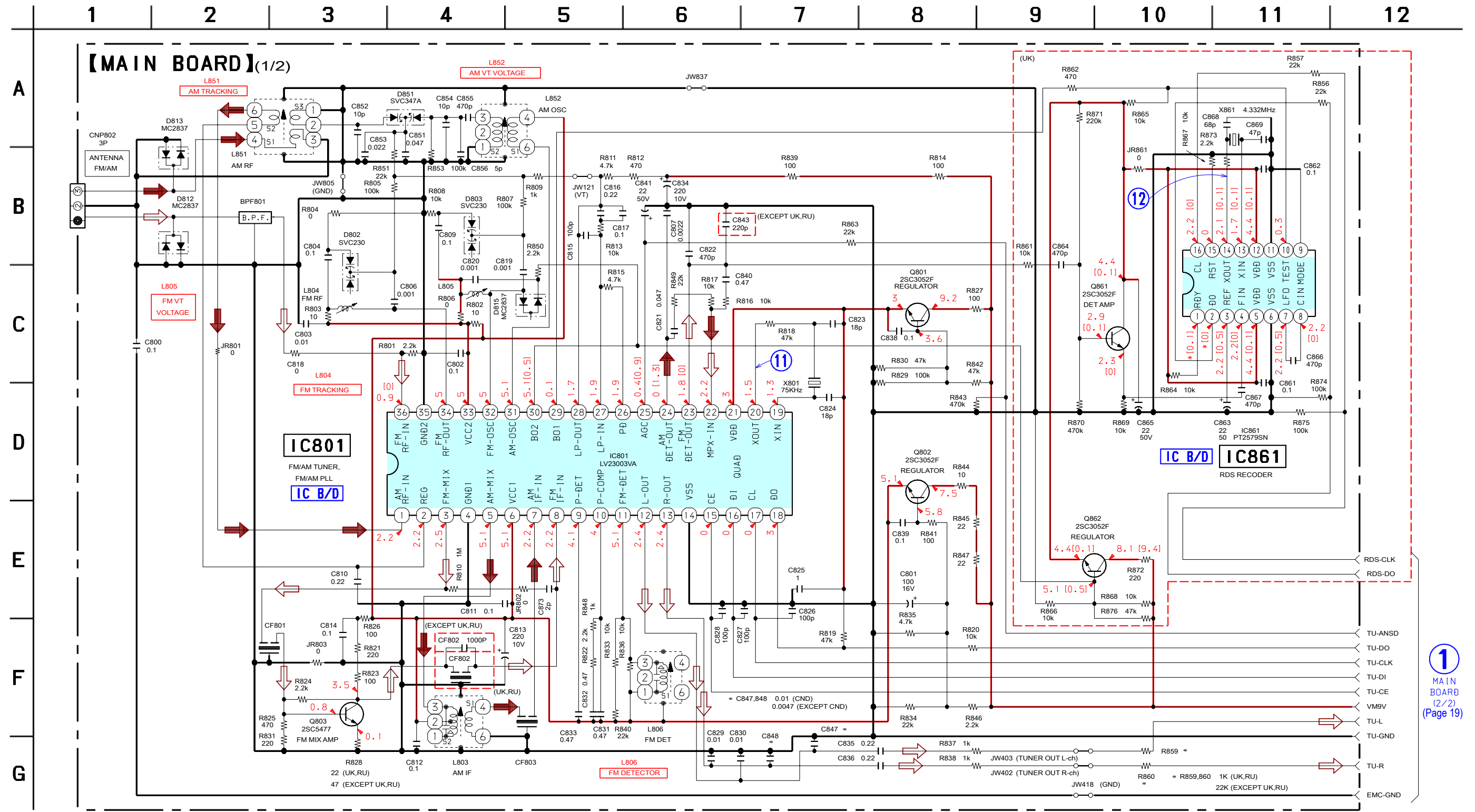

7-6. SCHEMATIC DIAGRAM - MAIN Section (2/2) - • See page 13 for Waveforms. • See Page 21 for IC Block Diagrams.

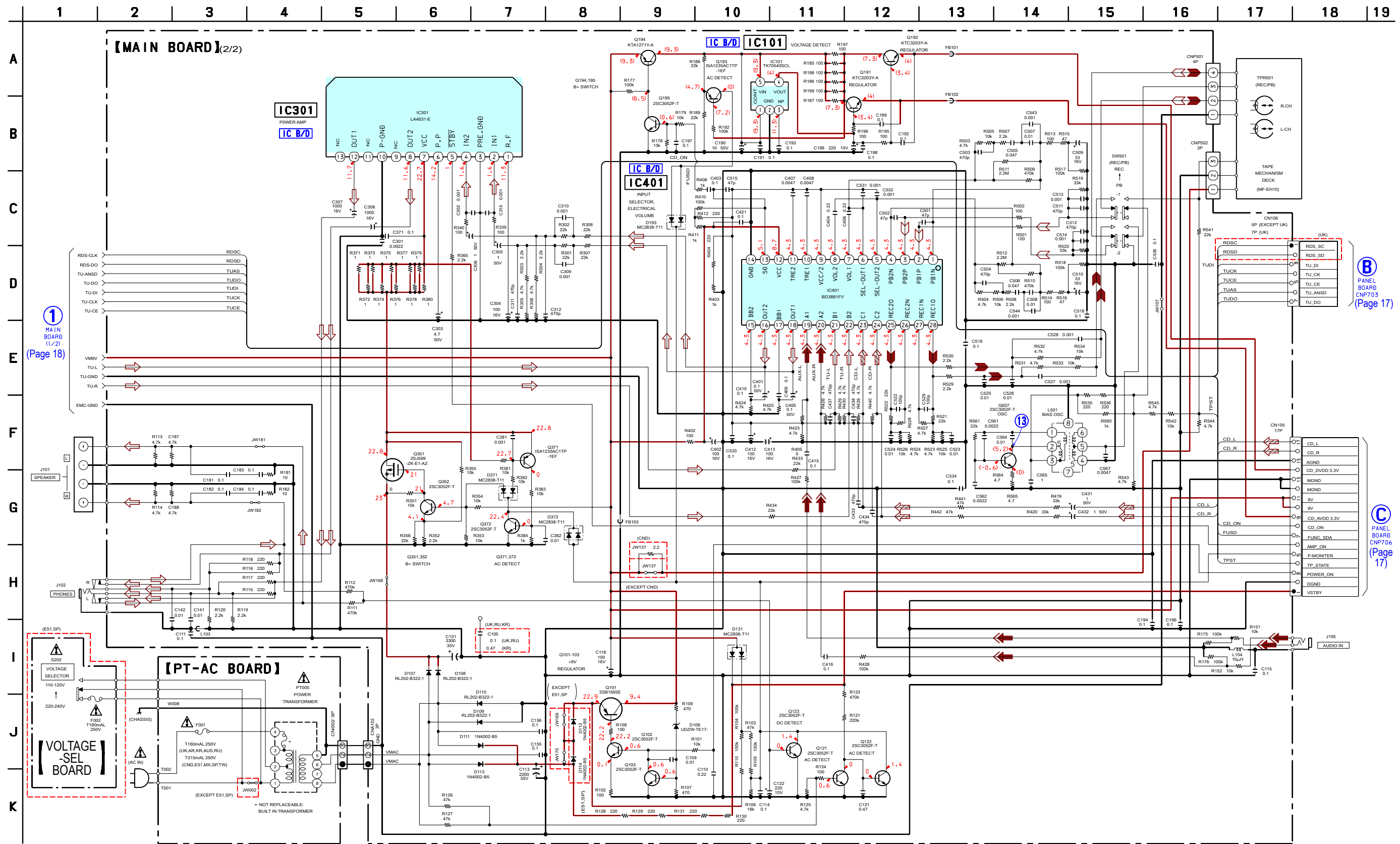

1 MAIN BOARD (1/2) (Page 18)

B PANEL BOARD CN703 (Page 17)

C PANEL BOARD CN706 (Page 17)

7-7. PRINTED WIRING BOARDS - MAIN Section - • See page 13 for Circuit Boards Location. •  : Uses unleaded solder.

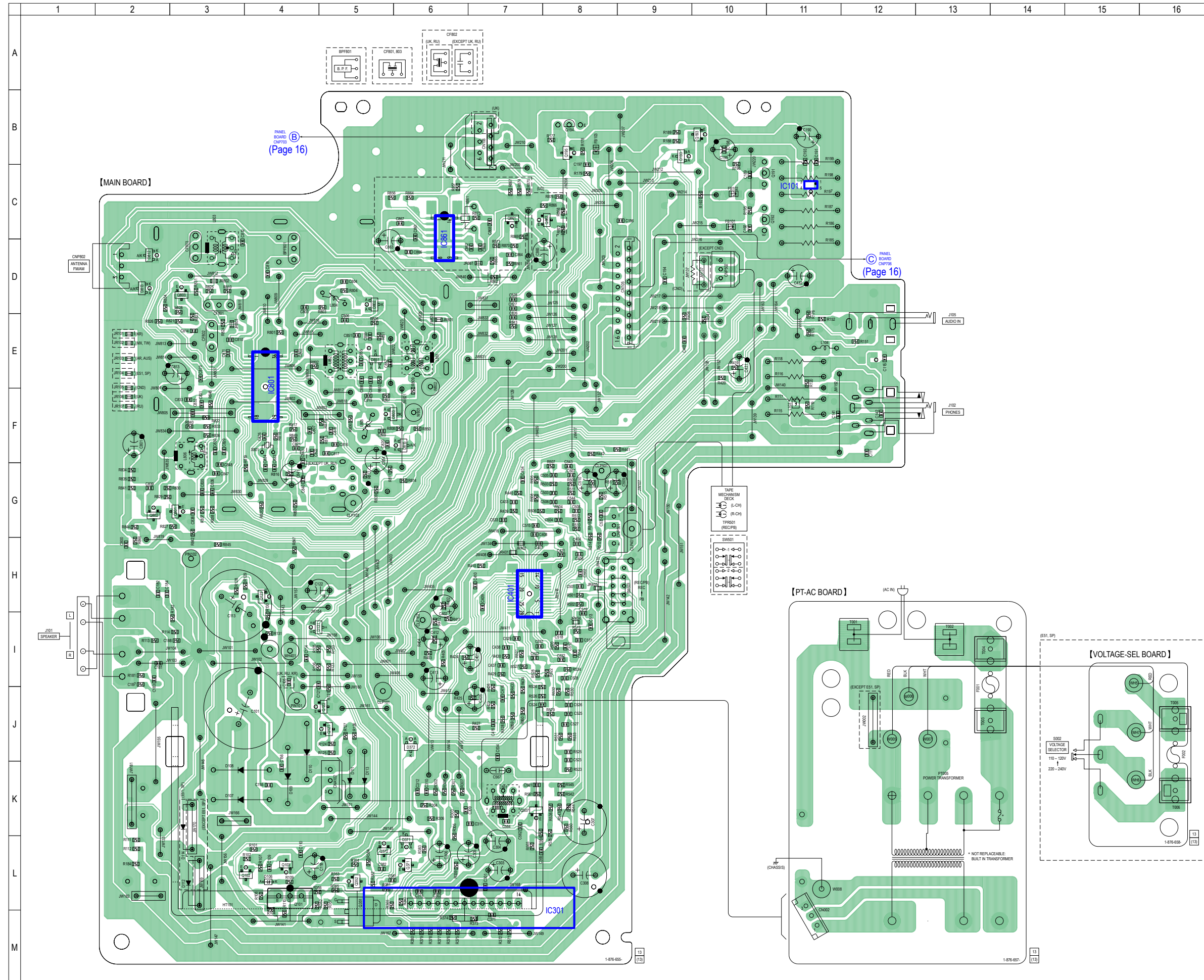

• Semiconductor Location

Ref. No.	Location
D106	L-4
D107	K-3
D108	K-3
D109	K-4
D110	J-4
D111	K-5
D112	L-3
D113	K-5
D114	K-3
D131	I-4
D193	B-9
D371	L-6
D372	J-6
D802	D-5
D803	F-6
D812	D-2
D813	D-2
D815	F-6
D851	E-5
IC101	C-11
IC301	L-6
IC401	H-7
IC801	E-4
IC861	C-6
Q101	L-4
Q102	L-4
Q103	L-4
Q121	J-5
Q122	J-5
Q123	H-4
Q191	C-10
Q192	C-10
Q193	B-10
Q194	B-8
Q195	B-8
Q351	M-5
Q352	L-5
Q371	L-6
Q372	L-5
Q507	K-7
Q801	G-3
Q802	G-2
Q803	D-3
Q861	C-7
Q862	C-8

• IC Block Diagrams  
 – CD Board –  
 IC201 TK63115SCL-G@GT

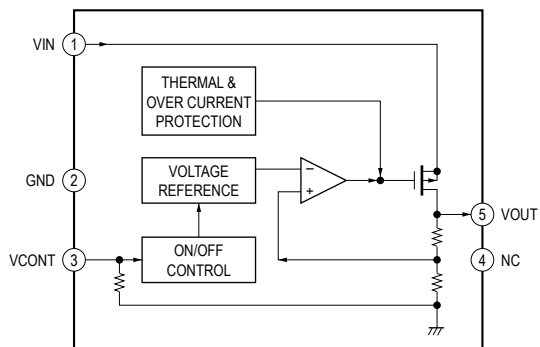

IC401 BA5826SFP-E2

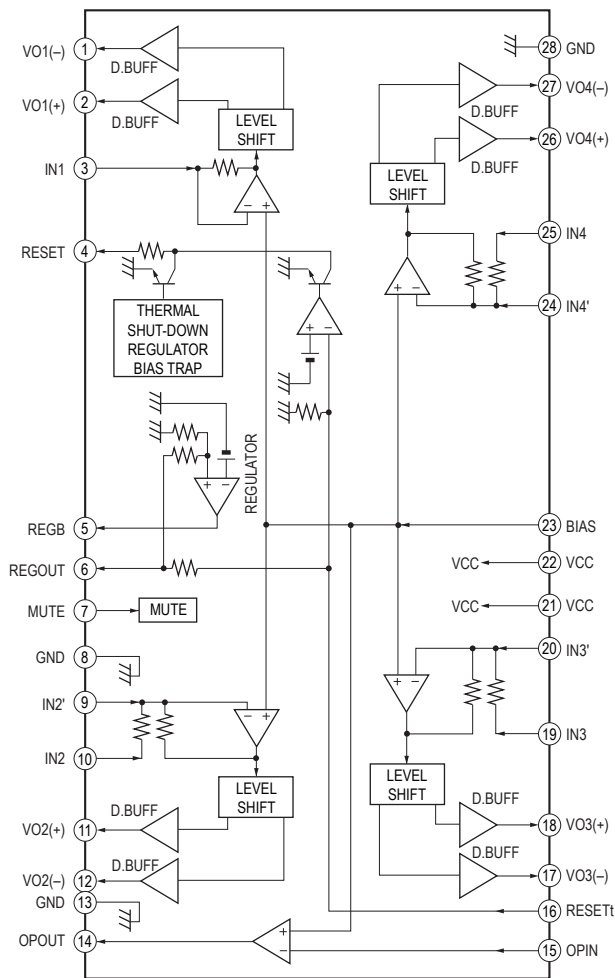

– MAIN Board –  
 IC101 TK70540SCL-G

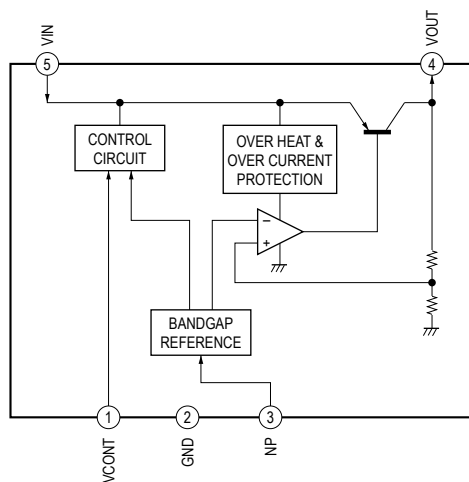

IC301 LA4631-E

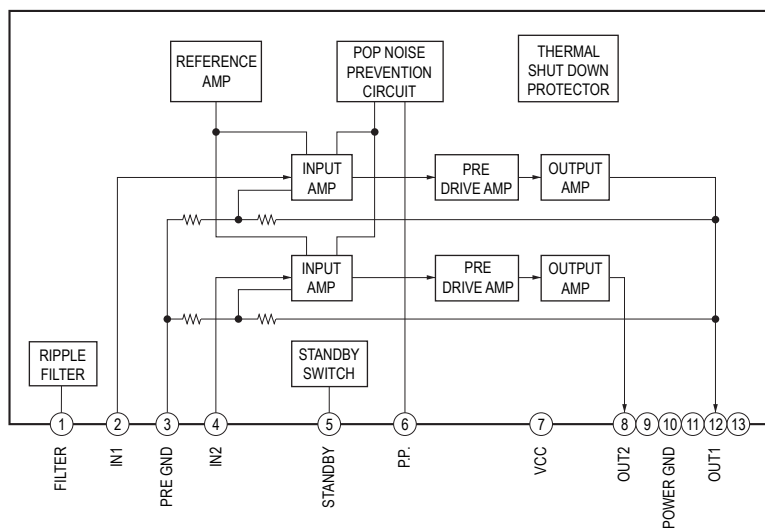

## IC401 BD3881FV

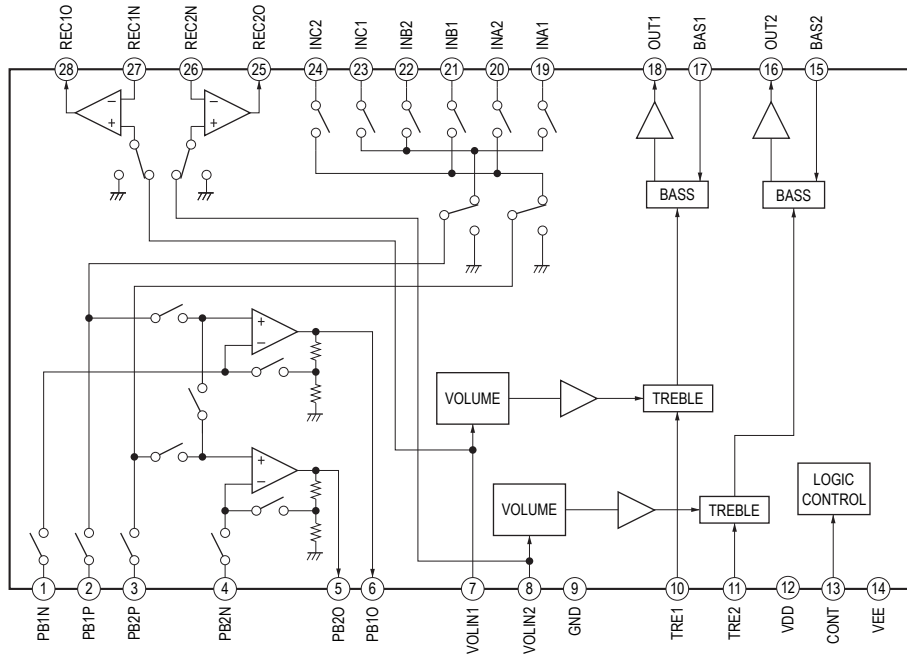

## IC861 PT2579SN

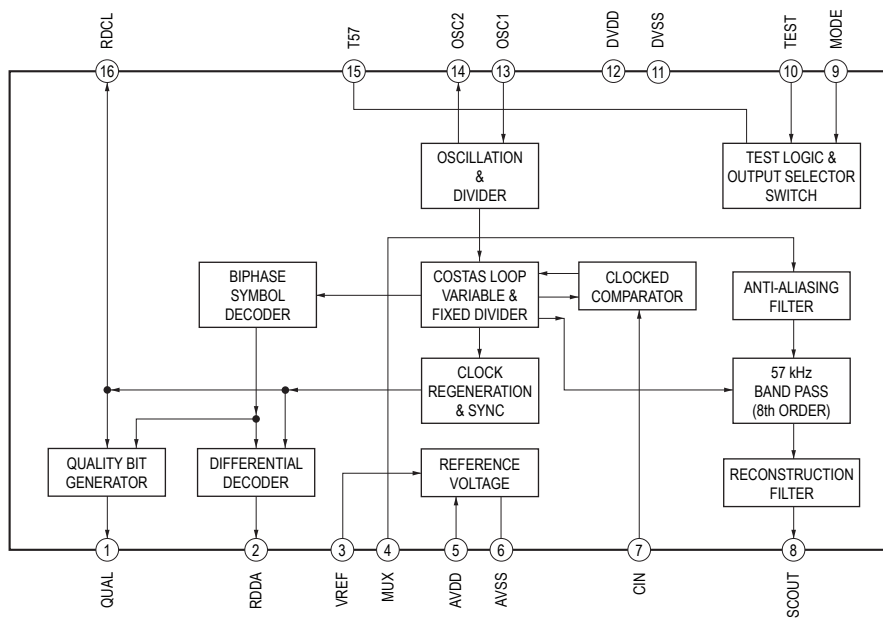

IC801 LV23003VA

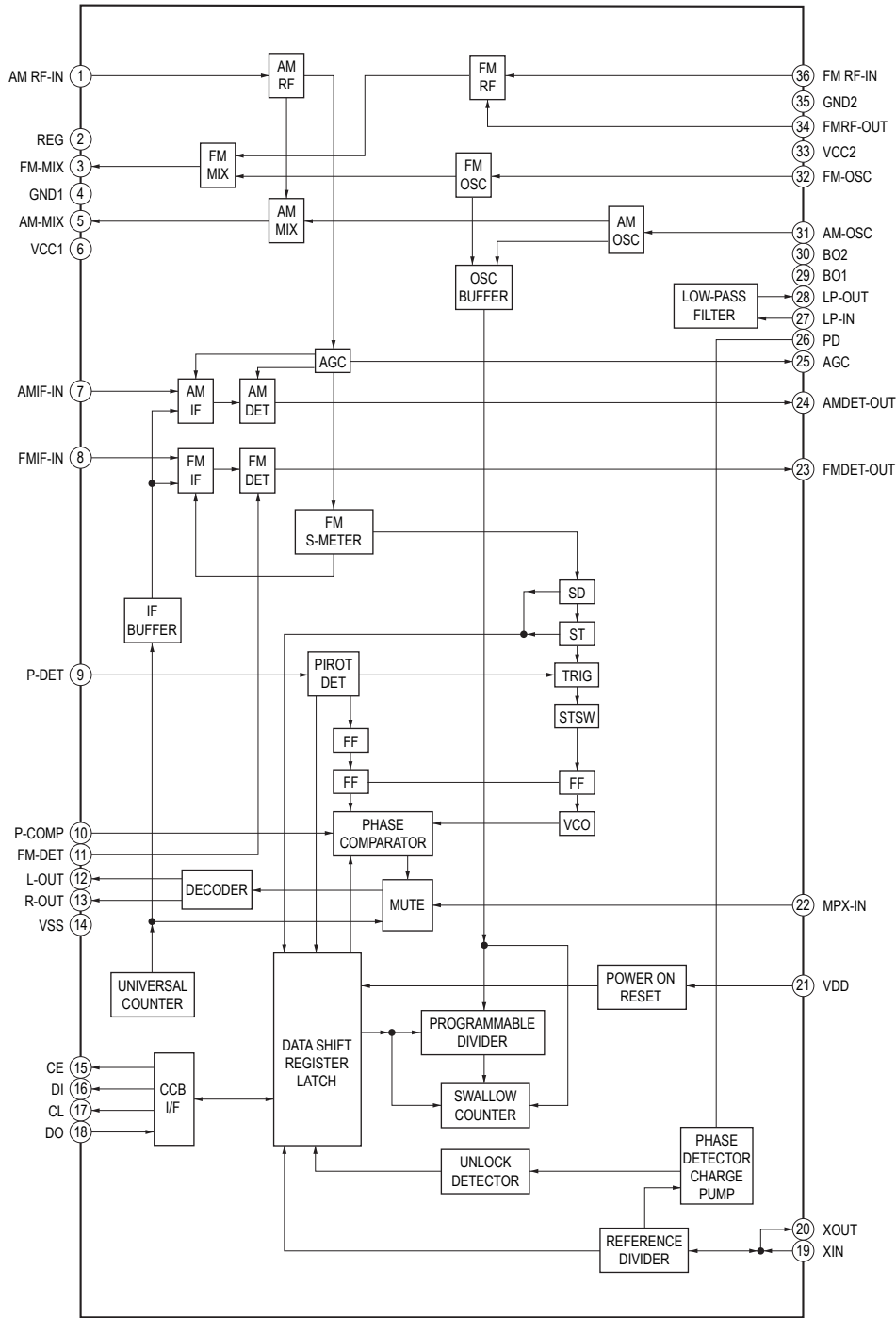

## • IC Pin Function Description

## CD BOARD IC101 (CD-MP3 PROCESSOR) TC94A70FG-006

Pin No.	Pin Name	I/O	Description
1	AVSS3	-	Ground terminal
2	RFZi	I	RF ripple zero crossing signal input terminal
3	RFRP	O	RF ripple signal output terminal
4	SBAD/RFDC	O	Sub beam addition signal or RF peak detection signal output terminal Not used
5	FEi	O	Focus error signal output terminal Not used
6	TEi	O	Tracking error signal output terminal
7	TEZi	I	Tracking error zero crossing signal input terminal
8	AVDD3	-	Power supply terminal (+3.3 V)
9	FOo	O	Focus coil drive signal output terminal
10	TRo	O	Tracking coil drive signal output terminal
11	VREF	I	Reference voltage (+1.65V) input terminal
12	FMo	O	Sled motor drive signal output terminal
13	DMo	O	Spindle motor drive signal output terminal
14	VSSP3	-	Ground terminal
15	VCOi	I	VCO control voltage input terminal
16	VDDP3	-	Power supply terminal (+3.3 V)
17	VDD1	-	Power supply terminal (+1.5 V)
18	VSS	-	Ground terminal
19	FGiN	I	FG signal input terminal Not used
20	IO0 (/HSO)	I	Disc inner position detection signal input terminal
21	IO1 (/UHSO)	O	Not used
22	XVSS3	-	Ground terminal
23	XI	I	System clock input terminal (16.9344 MHz)
24	XO	O	System clock output terminal (16.9344 MHz)
25	XVDD3	-	Power supply terminal (+3.3 V)
26	DVSS3	-	Ground terminal
27	RO	O	Audio data (R-ch) output to the input selector
28	DVDD3	-	Power supply terminal (+3.3 V)
29	DVR	O	Reference voltage (+1.65V) output terminal
30	LO	O	Audio data (L-ch) output to the input selector
31	DVSS3	-	Ground terminal
32	VDDT3	-	Power supply terminal (+3.3 V)
33	VSS1	-	Ground terminal
34	VDD1	-	Power supply terminal (+1.5 V)
35	VDDM1	-	Power supply terminal (+1.5 V)
36	SRAMSTB	I	S-RAM standby mode control signal input terminal Fixed at "L" in this set
37	XRST	I	Reset signal input from the system controller "L": reset
38, 39	BUS0, BUS1	I	Serial data input from the system controller
40	BUS2 (SO)	I	Serial data input from the system controller
41	BUS3 (SI)	I	Serial data input from the system controller
42	BUCK (CLK)	I	Serial data transfer clock signal input from the system controller
43	XCCE	I	Chip enable signal input from the system controller
44	TEST	I	Setting terminal for test mode Normally fixed at "L"
45	IRQ	I	Interrupt request signal input terminal Not used
46	AoUT3 (PO4)	O	Request signal output terminal Not used
47	AoUT2 (PO5)	O	Audio data output terminal Not used
48	PIO0	O	Request signal output to the system controller
49, 50	PIO1, PIO2	O	Not used
51	PIO3	I	Gate signal input terminal Not used
52	VSS1	-	Ground terminal
53	VDDT3	-	Power supply terminal (+3.3 V)
54	SBSY	O	Subcode block sync signal output to the system controller
55	SBOK/FOK	O	Not used
56	IPF	O	Not used



Pin No.	Pin Name	I/O	Description
57	SFSY/LOCK	O	Not used
58	ZDET	O	Zero detection signal output terminal Not used
59	GPIN	I	Not used
60	MS	I	Microcomputer interface mode selection signal input terminal Fixed at "H" in this set
61	DOUT (PO6)	O	Digital audio data output terminal Not used
62	AOUT (PO7)	O	Audio data output terminal Not used
63	BCK (PO8)	O	Bit clock signal output terminal Not used
64	LRCK (PO9)	O	L/R sampling clock signal output terminal Not used
65	AIN (PI4)	I	Digital audio data input terminal Not used
66	BCKi (PI5)	I	Bit clock signal input terminal Not used
67	LRCKi (PI6)	I	L/R sampling clock signal input terminal Not used
68	VDD1	-	Power supply terminal (+1.5 V)
69	VSS	-	Ground terminal
70	AWRC	-	Not used
71	PVDD3	-	Power supply terminal (+3.3 V)
72	PDO	O	Phase error margin signal between EFM signal and PLCK signal output terminal
73	TMAXS	O	TMAX detection signal output terminal Not used
74	TMAX	O	TMAX detection signal output terminal
75	LPFN	I	Inverted signal input from the operation amplifier for PLL loop filter
76	LPFo	O	Signal output from the operation amplifier for PLL loop filter
77	PVREF	I	Reference voltage (+1.65V) input terminal
78	VCOF	O	VCO filter output terminal
79	PVSS3	-	Ground terminal
80	SLCo	O	EFM slice level output terminal
81	RFi	I	RF signal input terminal
82	RFRPi	I	RF ripple signal input terminal
83	RFEQo	O	EFM slice level output terminal
84	VRo	O	Reference voltage (+1.65V) output terminal
85	RESiN	O	External resistor connection terminal
86	VMDiR	O	Reference voltage (+1.65V) output terminal for automatic power control circuit
87	TESTR	O	Low-pass filter terminal for RFEQO offset correction
88	AGCi	I	RF signal amplitude adjustment amplification input terminal
89	RFo	O	RF signal generation amplification output terminal
90	RVDD3	-	Power supply terminal (+3.3 V)
91	LDo	O	Laser diode on/off control signal output to the automatic power control circuit "H": laser diode on
92	MDi	I	Light amount monitor input from the laser diode of optical pick-up block
93	RVSS3	-	Ground terminal
94	FNi2 (C)	I	Main beam (C) input from the optical pick-up block
95	FNi1 (A)	I	Main beam (A) input from the optical pick-up block
96	FPi2 (D)	I	Main beam (D) input from the optical pick-up block
97	FPi1 (B)	I	Main beam (B) input from the optical pick-up block
98	TPi (F)	I	Sub beam (F) input from the optical pick-up block
99	TNPC	O	External capacitor connection terminal
100	TNi (E)	I	Sub beam (E) input from the optical pick-up block

## PANEL BOARD IC701 MB90F830PF-GE1 (SYSTEM CONTROLLER)

Pin No.	Pin Name	I/O	Description
1	LED	O	LED drive signal output terminal for liquid crystal display back light "H": LED on
2	CD OPEN/CLOSE	I	CD lid open/close detection switch input terminal "L": CD lid is closed
3	REQ	I	Request signal input from the CD-MP3 processor
4	MMUT	O	Muting signal output to the coil/motor driver
5 to 8	BUS0 to BUS3	O	Serial data output to the CD-MP3 processor
9	RMC	I	Remote control signal input from the remote control receiver
10	BUCK	O	Serial data transfer clock signal output to the CD-MP3 processor
11	XCCEN	O	Chip enable signal output to the CD-MP3 processor
12	XRST	O	Reset signal output to the CD-MP3 processor "L": reset
13	X2	I	Sub system clock input terminal (32.768 kHz)
14	X3	O	Sub system clock output terminal (32.768 kHz)
15	VCC	-	Power supply terminal (+3.3V)
16	VSS	-	Ground terminal
17 to 21	NC	-	Not used
22	LED_STBY	O	LED drive signal output terminal for STANDBY indicator "L": LED on
23	CD_ON	O	Power supply on/off control signal output terminal for CD section "H": power on
24	NC	-	Not used
25	TU_DO	I	Serial data input from the FM/AM tuner
26	RDA_DATA	I	RDS serial data input from the RDS decoder (UK model only)
27 to 31	NC	-	Not used
32	AVCC	-	Power supply terminal (+3.3V)
33	FUNC_SDA	O	Serial data output to the electrical volume
34	AMP_ON	O	Standby control signal output to the power amplifier "L": standby
35	AVSS	-	Ground terminal
36	P_MONI	I	Power monitor input terminal
37, 38	KEY1, KEY2	I	Front panel key input terminal (A/D input)
39	TU_ASD	I	Auto gain control signal input from the FM/AM tuner
40	TP_STATE	I	REC/PB detection signal input terminal
41	KEY0	I	Power key input terminal
42	HOLD	I	Hold signal input terminal
43	SBSY	I	Subcode block sync signal input from the CD-MP3 processor
44	VSS	-	Ground terminal
45	RDS_CLK	I	RDS serial data transfer clock signal input from the RDS decoder (UK model only)
46	POWER_ON	O	Main power supply on/off control signal output terminal "H": power on
47	SUFIX	I	Destination setting terminal
48	RE_VOL	I	Jog dial pulse input from the rotary encoder (for VOLUME)
49, 50	NC	-	Not used
51	MD2	I	Mode setting terminal Fixed at "L" in this set
52, 53	MD1, MD0	I	Mode setting terminal Fixed at "H" in this set
54	RESET	I	Reset signal input terminal "L": reset For several hundreds msec. after the power supply rises, "L" is input, then it changes to "H"
55	TU_CE	O	Chip enable signal output to the FM/AM tuner
56	TU_CLK	O	Serial data transfer clock signal output to the FM/AM tuner
57	TU_DI	O	Serial data output to the FM/AM tuner
58	V3	-	Terminal for doubler circuit capacitor connection to develop liquid crystal display drive voltage
59 to 62	COM0 to COM3	O	Common drive signal output to the liquid crystal display
63, 64	SEG0, SEG1	O	Segment drive signal output to the liquid crystal display
65	VCC	-	Power supply terminal (+3.3V)
66	VSS	-	Ground terminal
67 to 89	SEG2 to SEG24	O	Segment drive signal output to the liquid crystal display
90	VCC	-	Power supply terminal (+3.3V)
91	VSS	-	Ground terminal
92	X1	I	Main system clock output terminal (5.53 MHz)
93	X0	O	Main system clock input terminal (5.53 MHz)
94 to 100	SEG25 to SEG31	O	Segment drive signal output to the liquid crystal display

SECTION 8  
EXPLODED VIEWS

Note:

- XX and -X mean standardized parts, so they may have some difference from the original one.
- Items marked "\*" are not stocked since they are seldom required for routine service. Some delay should be anticipated when ordering these items.
- The mechanical parts with no reference number in the exploded views are not supplied.

- Color Indication of Appearance Parts Example:  
KNOB, BALANCE (WHITE) . . . (RED)  
↑ ↑  
Parts Color Cabinet's Color
- Accessories are given in the last of the electrical parts list.
- Abbreviation  
AR : Argentina model  
AUS : Australian model  
CND : Canadian model  
E51 : Chilean and Peruvian model  
KR : Korean model

- MX : Mexican model
- RU : Russian model
- SP : Singapore model
- TW : Taiwan model

<p>The components identified by mark Δ or dotted line with mark Δ are critical for safety. Replace only with part number specified.</p> <p>Les composants identifiés par une marque Δ sont critiques pour la sécurité. Ne les remplacer que par une pièce portant le numéro spécifié.</p>
---

8-1. OVERALL SECTION

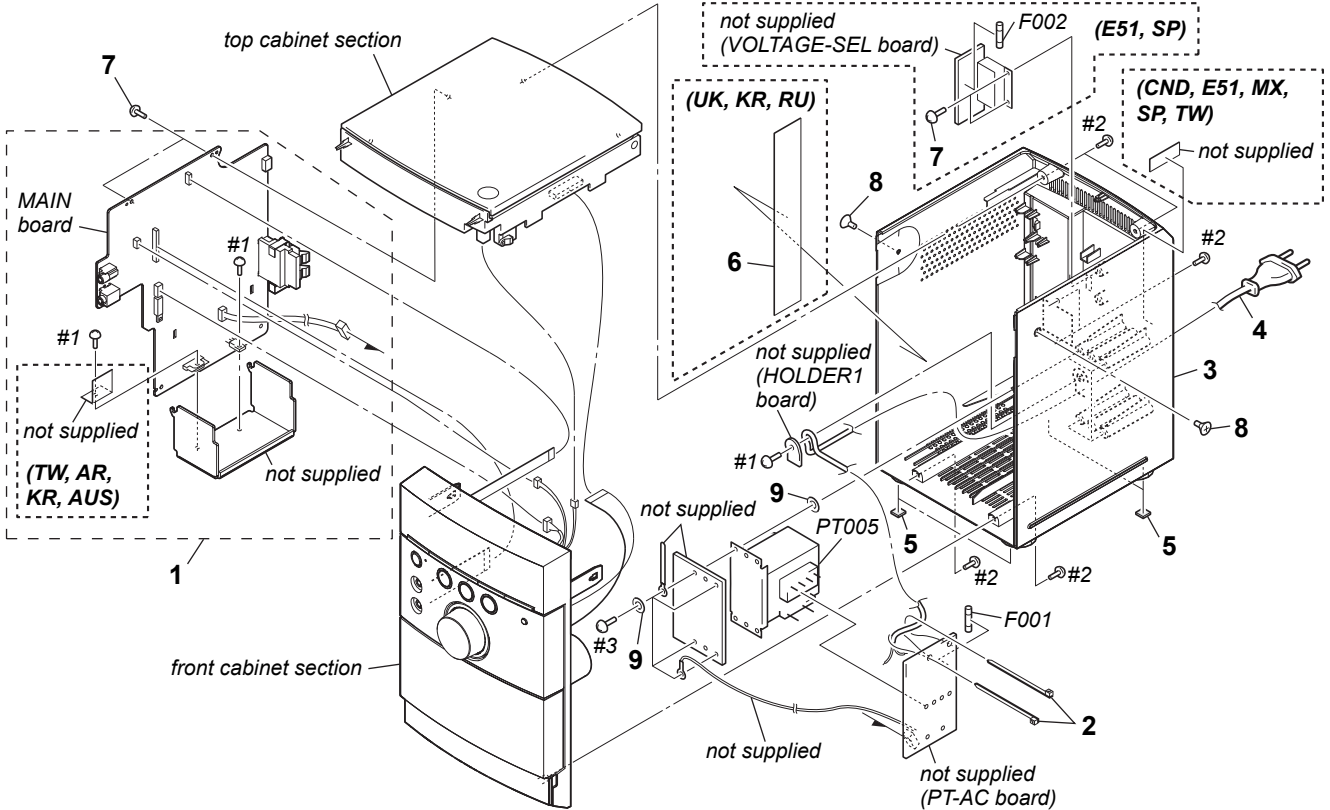

Ref. No.	Part No.	Description	Remark	Ref. No.	Part No.	Description	Remark
1	A-1508-439-A	MAIN BOARD, COMPLETE (UK)		Δ 4	1-832-228-11	CORD, POWER (AR)	
1	A-1508-519-A	MAIN BOARD, COMPLETE (CND)		5	3-198-753-11	FOOT (FELT)	
1	A-1508-544-A	MAIN BOARD, COMPLETE (AR, AUS)		6	3-700-085-01	SHEET, COPPER LEAF (UK, KR, RU)	
1	A-1508-664-A	MAIN BOARD, COMPLETE (E51, SP)					
1	A-1508-703-A	MAIN BOARD, COMPLETE (KR)		7	3-087-053-01	+BVTP2.6 (3CR)	
1	A-1508-735-A	MAIN BOARD, COMPLETE (MX, TW)		8	2-580-644-01	SCREW, +KTP2 3X8	
1	A-1542-780-A	MAIN BOARD, COMPLETE (RU)		9	3-572-085-00	WASHER, FIBER	
2	3-701-748-00	CORD, POWER (KR)		Δ F001	1-532-275-33	FUSE (T160mAL/250V) (UK, AR, KR, AUS, RU)	
3	3-287-571-01	CABINET, REAR (UK, TW, AR, KR, AUS, RU)		Δ F001	1-532-467-33	FUSE (T315mAL/250V) (CND, E51, MX, SP, TW)	
3	3-287-571-11	CABINET, REAR (CND)		Δ F002	1-532-275-33	FUSE (T160mAL/250V) (E51, SP)	
3	3-287-571-21	CABINET, REAR (E51, SP)		Δ PT005	1-445-421-11	TRANSFORMER, POWER (AR, KR)	
3	3-287-571-31	CABINET, REAR (MX)		Δ PT005	1-445-422-11	TRANSFORMER, POWER (UK, RU)	
Δ 4	1-769-079-51	CORD, POWER (KR)		Δ PT005	1-445-423-11	TRANSFORMER, POWER (E51, SP, AUS)	
Δ 4	1-775-790-81	CORD, POWER (AUS)		Δ PT005	1-445-424-11	TRANSFORMER, POWER (CND, MX, TW)	
Δ 4	1-790-757-52	CORD, POWER (CND, MX)		#1	7-685-646-79	SCREW +BVTP 3X8 TYPE2 IT-3	
Δ 4	1-827-597-81	CORD, POWER (TW)		#2	7-685-647-79	SCREW +BVTP 3X10 TYPE2 IT-3	
Δ 4	1-830-891-11	CORD, POWER (UK, E51, SP, RU)		#3	7-685-649-79	SCREW +BVTP 3X14 TYPE2 IT-3	

## 8-2. FRONT CABINET SECTION

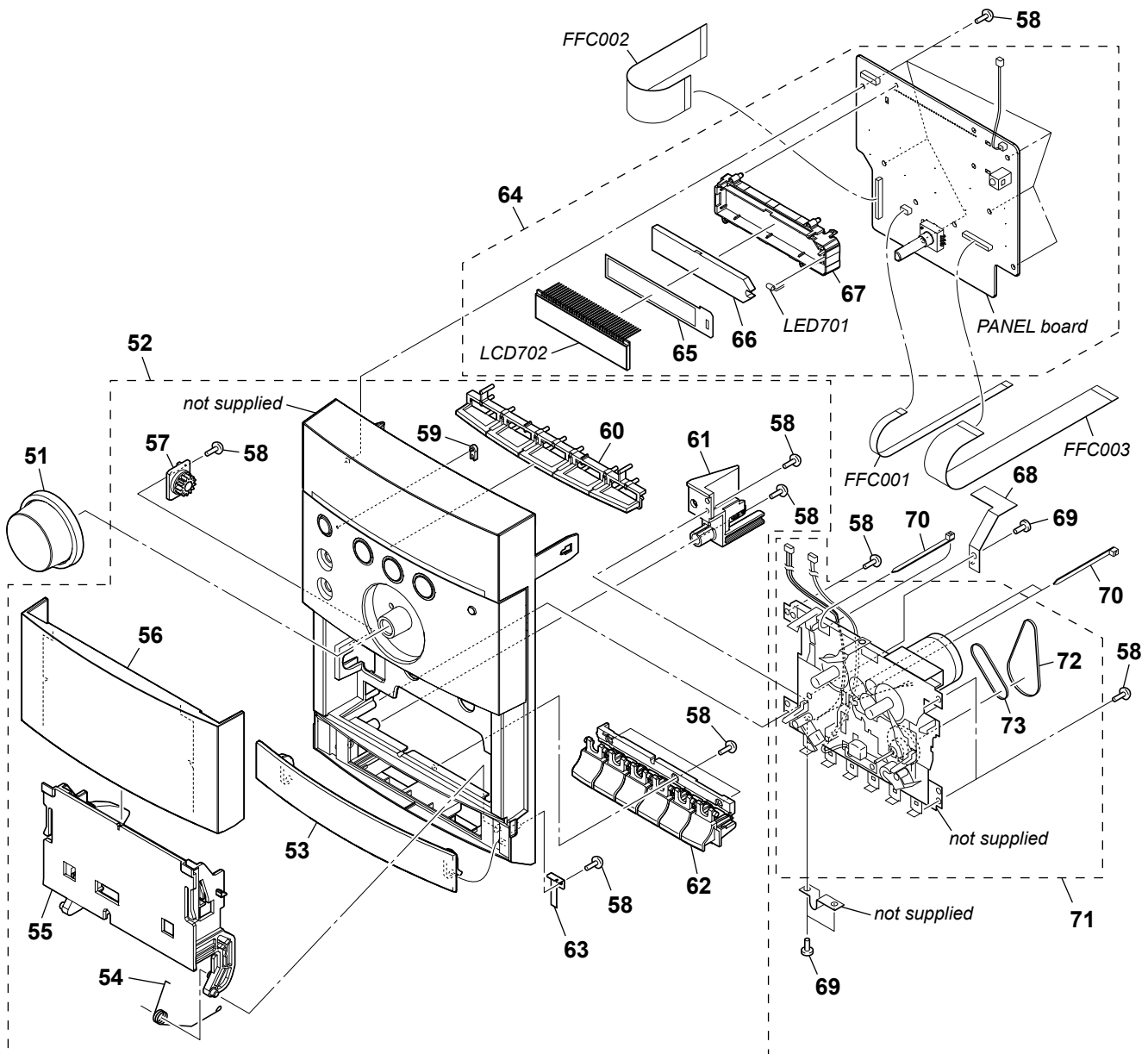

Ref. No.	Part No.	Description	Remark	Ref. No.	Part No.	Description	Remark
51	3-280-084-01	KNOB (VOL)		64	A-1527-693-A	PANEL BOARD, COMPLETE (AUS)	
52	A-1508-461-A	CABINET ASSY, FRONT (EXCEPT UK, RU)		64	A-1542-781-A	PANEL BOARD, COMPLETE (RU)	
52	A-1518-789-A	CABINET ASSY, FRONT (UK)		65	2-636-545-01	SHEET (LCD)	
52	A-1551-700-A	CABINET ASSY, FRONT (RU)		66	2-636-532-01	ILLUMINATOR (LCD)	
53	3-280-079-01	BUTTON COVER (C)		67	2-636-531-01	HOLDER (LCD)	
54	2-637-768-01	SPRING (CASSETTE)		68	2-636-546-01	LEVER (REC)	
55	3-288-035-01	HOLDER (CASSETTE)		69	3-254-022-01	SCREW	
56	3-280-077-01	LID, CASSETTE		70	3-701-748-00	CLAMP	
57	3-047-468-01	DAMPER		71	A-1313-349-A	MF-EH10 (TAPE MECHANISM DECK)	
58	3-087-053-01	+BVTP2.6 (3CR)		72	2-670-389-01	BELT (1)	
59	3-280-087-01	LENS (POWER)		73	3-214-817-01	BELT (FR)	
60	3-280-083-01	BUTTON (OPERATION)		FFC001	1-832-796-21	CABLE, FLEXIBLE FLAT (5 CORE) (RU)	
61	2-636-524-01	HOLDER, PWB		FFC001	1-832-797-21	CABLE, FLEXIBLE FLAT (5 CORE)	(EXCEPT UK, RU)
62	3-280-081-01	BUTTON (CASSETTE)	(●, ▶, ◀, ►, ■, ▲,   )	FFC001	1-832-807-21	CABLE, FLEXIBLE FLAT (7 CORE) (UK)	
63	3-280-088-01	SPRING (C-BUTTON LID)		FFC002	1-832-854-21	CABLE, FLEXIBLE FLAT (17 CORE)	
64	A-1508-455-A	PANEL BOARD, COMPLETE (UK)		FFC003	1-835-211-21	CABLE, FLEXIBLE FLAT	
64	A-1508-530-A	PANEL BOARD, COMPLETE (CND)		LCD702	1-802-381-11	DISPLAY PANEL, LIQUID CRYSTAL	
64	A-1508-558-A	PANEL BOARD, COMPLETE (SP, TW, KR)		LED701	6-502-498-01	LED SELU2B10A-SLF62FGH (LCD BACK LIGHT)	
64	A-1508-593-A	PANEL BOARD, COMPLETE (E51, MX, AR)					

8-3. TOP CABINET SECTION

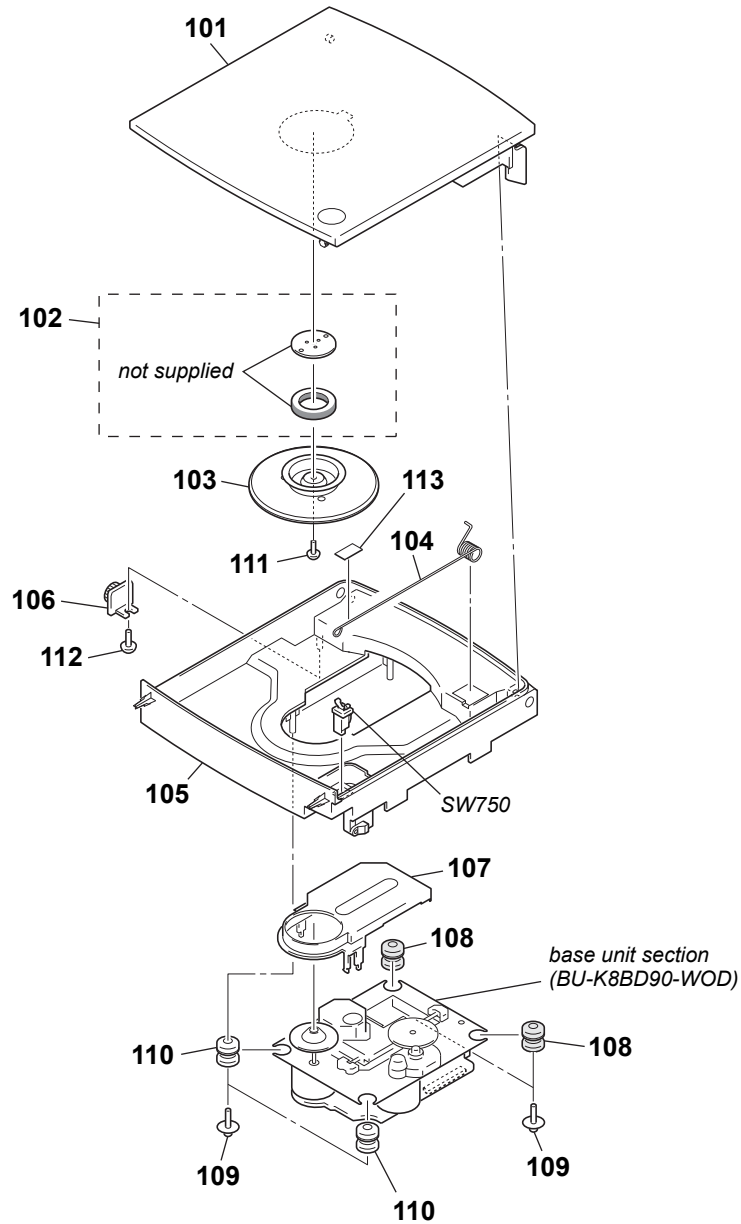

Ref. No.	Part No.	Description	Remark	Ref. No.	Part No.	Description	Remark
101	2-636-518-31	LID, CD		109	3-252-828-01	SCREW (B2.6), (+) PWH TAPPING	
102	1-452-899-11	MAGNET		110	3-931-379-31	RUBBER, VIBRATION PROOF (GREEN)	
103	3-019-395-01	PLATE, CHUCKING		111	3-253-143-01	SCREW (B2.6), (+) P TAPPING	
104	2-637-769-01	SPRING (CD)		112	3-087-053-01	+BVTP2.6 (3CR)	
105	2-636-515-02	CABINET, TOP		113	2-675-085-01	SPACER	
106	3-047-468-11	DAMPER		SW750	1-692-960-11	SWITCH, PUSH (1 KEY) (CD LID OPEN/CLOSE DETECT)	
107	4-247-493-01	COVER, CD					
108	3-931-379-21	RUBBER, VIBRATION PROOF (RED)					

## 8-4. BASE UNIT SECTION (BU-K8BD90-WOD)

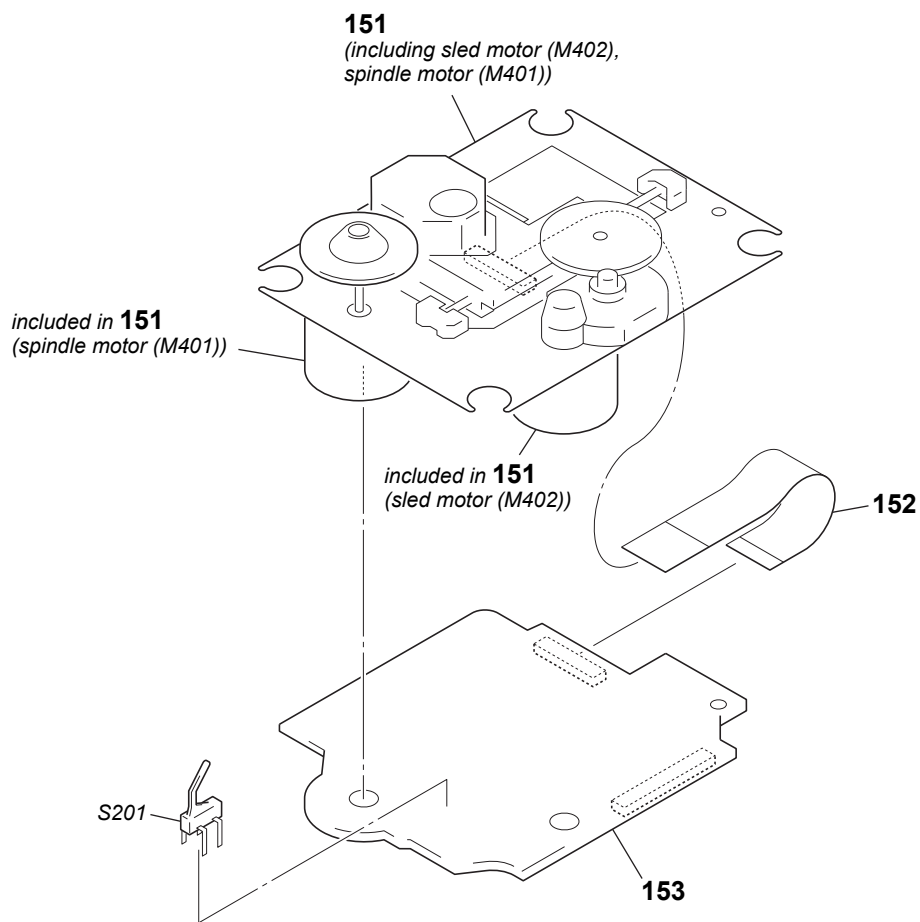

Ref. No.	Part No.	Description	Remark	Ref. No.	Part No.	Description	Remark
△ 151	8-820-126-02	OPTICAL PICK-UP BLOCK (KSM-213CDP/C2NP) (Including spindle motor (M401), sled motor (M402))		153	A-1217-914-A	CD BOARD, COMPLETE	
152	1-834-268-21	WIRE (FLAT TYPE) (16 CORE)		S201	1-771-853-11	SWITCH, DETECTION (LIMIT)	

## SECTION 9 ELECTRICAL PARTS LIST

CD

**Note:**

- Due to standardization, replacements in the parts list may be different from the parts specified in the diagrams or the components used on the set.
- -XX and -X mean standardized parts, so they may have some difference from the original one.
- Items marked "\*" are not stocked since they are seldom required for routine service.  
Some delay should be anticipated when ordering these items.
- CAPACITORS  
uF:  $\mu$ F
- COILS  
uH:  $\mu$ H

- RESISTORS  
All resistors are in ohms.  
METAL: Metal-film resistor.  
METAL OXIDE: Metal oxide-film resistor.  
F: nonflammable
- SEMICONDUCTORS  
In each case, u:  $\mu$ , for example:  
uA. . . :  $\mu$ A. . . ,  $\mu$ PA. . . ,  $\mu$ PA. . . ,  
uPB. . . :  $\mu$ PB. . . ,  $\mu$ PC. . . ,  $\mu$ PC. . . ,  
uPD. . . :  $\mu$ PD. . .
- Abbreviation  
AR : Argentina model  
AUS : Australian model  
CND : Canadian model  
E51 : Chilean and Peruvian model  
KR : Korean model

- MX : Mexican model  
RU : Russian model  
SP : Singapore model  
TW : Taiwan model

When indicating parts by reference number, please include the board name.

The components identified by mark  $\triangle$  or dotted line with mark  $\triangle$  are critical for safety.  
Replace only with part number specified.

Les composants identifiés par une marque  $\triangle$  sont critiques pour la sécurité.  
Ne les remplacer que par une pièce portant le numéro spécifié.

Ref. No.	Part No.	Description	Remark	Ref. No.	Part No.	Description	Remark
	A-1217-914-A	CD BOARD, COMPLETE *****					
		< CAPACITOR >					
C100	1-164-360-11	CERAMIC CHIP 0.1uF	16V	C147	1-107-826-11	CERAMIC CHIP 0.1uF	10% 16V
C101	1-164-360-11	CERAMIC CHIP 0.1uF	16V	C148	1-162-923-11	CERAMIC CHIP 47PF	5% 50V
C102	1-164-360-11	CERAMIC CHIP 0.1uF	16V	C149	1-162-919-11	CERAMIC CHIP 22PF	5% 50V
C103	1-164-360-11	CERAMIC CHIP 0.1uF	16V	C150	1-162-964-11	CERAMIC CHIP 0.001uF	10% 50V
C104	1-164-360-11	CERAMIC CHIP 0.1uF	16V	C151	1-164-315-11	CERAMIC CHIP 470PF	5% 50V
C105	1-164-360-11	CERAMIC CHIP 0.1uF	16V	C152	1-164-315-11	CERAMIC CHIP 470PF	5% 50V
C106	1-128-995-21	ELECT CHIP 100uF	20% 10V	C153	1-164-360-11	CERAMIC CHIP 0.1uF	16V
C107	1-164-360-11	CERAMIC CHIP 0.1uF	16V	C201	1-128-995-21	ELECT CHIP 100uF	20% 10V
C108	1-164-360-11	CERAMIC CHIP 0.1uF	16V	C202	1-128-995-21	ELECT CHIP 100uF	20% 10V
C109	1-164-360-11	CERAMIC CHIP 0.1uF	16V	C204	1-164-360-11	CERAMIC CHIP 0.1uF	16V
C110	1-164-360-11	CERAMIC CHIP 0.1uF	16V	C205	1-164-360-11	CERAMIC CHIP 0.1uF	16V
C112	1-164-360-11	CERAMIC CHIP 0.1uF	16V	C206	1-165-908-11	CERAMIC CHIP 1uF	10% 10V
C113	1-164-360-11	CERAMIC CHIP 0.1uF	16V	C207	1-165-908-11	CERAMIC CHIP 1uF	10% 10V
C115	1-124-778-00	ELECT CHIP 22uF	20% 6.3V	C301	1-164-360-11	CERAMIC CHIP 0.1uF	16V
C116	1-164-360-11	CERAMIC CHIP 0.1uF	16V	C302	1-137-710-91	CERAMIC CHIP 10uF	20% 6.3V
C117	1-164-227-11	CERAMIC CHIP 0.022uF	10% 25V	C303	1-137-710-91	CERAMIC CHIP 10uF	20% 6.3V
C118	1-162-970-11	CERAMIC CHIP 0.01uF	10% 25V	C306	1-128-995-21	ELECT CHIP 100uF	20% 10V
C119	1-164-227-11	CERAMIC CHIP 0.022uF	10% 25V	C307	1-165-908-11	CERAMIC CHIP 1uF	10% 10V
C120	1-162-970-11	CERAMIC CHIP 0.01uF	10% 25V	C309	1-162-964-11	CERAMIC CHIP 0.001uF	10% 50V
C122	1-164-315-11	CERAMIC CHIP 470PF	5% 50V	C401	1-128-394-11	ELECT CHIP 220uF	20% 10V
C123	1-164-315-11	CERAMIC CHIP 470PF	5% 50V	C403	1-164-360-11	CERAMIC CHIP 0.1uF	16V
C124	1-162-968-11	CERAMIC CHIP 0.0047uF	10% 50V	C404	1-164-360-11	CERAMIC CHIP 0.1uF	16V
C125	1-162-968-11	CERAMIC CHIP 0.0047uF	10% 50V	C405	1-164-360-11	CERAMIC CHIP 0.1uF	16V
C126	1-107-826-11	CERAMIC CHIP 0.1uF	10% 16V			< CONNECTOR >	
C127	1-162-966-11	CERAMIC CHIP 0.0022uF	10% 50V	CN201	1-784-833-51	CONNECTOR, FFC (LIF (NON-ZIF)) 21P	
C128	1-162-910-11	CERAMIC CHIP 5PF	0.25PF 50V	CN301	1-770-425-51	CONNECTOR, FFC/FPC 16P	
C130	1-162-910-11	CERAMIC CHIP 5PF	0.25PF 50V			< IC >	
C132	1-164-360-11	CERAMIC CHIP 0.1uF	16V	IC101	6-709-624-01	IC TC94A70FG-006	
C133	1-107-826-11	CERAMIC CHIP 0.1uF	10% 16V	IC201	6-710-808-01	IC TK63115SCL-G@GT	
C136	1-162-923-11	CERAMIC CHIP 47PF	5% 50V	IC401	6-710-637-01	IC BA5826SFP-E2	
C137	1-162-970-11	CERAMIC CHIP 0.01uF	10% 25V			< TRANSISTOR >	
C138	1-164-315-11	CERAMIC CHIP 470PF	5% 50V	Q301	6-551-120-01	TRANSISTOR 2SA2119K	
C139	1-162-970-11	CERAMIC CHIP 0.01uF	10% 25V			< RESISTOR >	
C140	1-162-970-11	CERAMIC CHIP 0.01uF	10% 25V	R101	1-216-813-11	METAL CHIP 220	5% 1/10W
C141	1-162-966-11	CERAMIC CHIP 0.0022uF	10% 50V	R102	1-216-833-11	METAL CHIP 10K	5% 1/10W
C142	1-107-826-11	CERAMIC CHIP 0.1uF	10% 16V	R104	1-216-295-91	SHORT CHIP 0	
C143	1-162-970-11	CERAMIC CHIP 0.01uF	10% 25V	R105	1-216-857-11	METAL CHIP 1M	5% 1/10W
C144	1-107-826-11	CERAMIC CHIP 0.1uF	10% 16V	R106	1-216-821-11	METAL CHIP 1K	5% 1/10W
C145	1-162-970-11	CERAMIC CHIP 0.01uF	10% 25V	R108	1-216-864-11	SHORT CHIP 0	
C146	1-164-315-11	CERAMIC CHIP 470PF	5% 50V	R110	1-216-833-11	METAL CHIP 10K	5% 1/10W

# HCD-EH15

**CD** **MAIN**

Ref. No.	Part No.	Description			Remark
R111	1-216-809-11	METAL CHIP	100	5%	1/10W
R112	1-216-809-11	METAL CHIP	100	5%	1/10W
R113	1-216-833-11	METAL CHIP	10K	5%	1/10W
R114	1-216-833-11	METAL CHIP	10K	5%	1/10W
R118	1-216-845-11	METAL CHIP	100K	5%	1/10W
R120	1-216-864-11	SHORT CHIP	0		
R125	1-216-864-11	SHORT CHIP	0		
R126	1-216-864-11	SHORT CHIP	0		
R127	1-216-864-11	SHORT CHIP	0		
R128	1-216-853-11	METAL CHIP	470K	5%	1/10W
R129	1-216-821-11	METAL CHIP	1K	5%	1/10W
R130	1-216-829-11	METAL CHIP	4.7K	5%	1/10W
R134	1-216-857-11	METAL CHIP	1M	5%	1/10W
R135	1-216-853-11	METAL CHIP	470K	5%	1/10W
R136	1-216-837-11	METAL CHIP	22K	5%	1/10W
R139	1-216-841-11	METAL CHIP	47K	5%	1/10W
R140	1-216-864-11	SHORT CHIP	0		
R142	1-216-837-11	METAL CHIP	22K	5%	1/10W
R143	1-216-841-11	METAL CHIP	47K	5%	1/10W
R144	1-216-837-11	METAL CHIP	22K	5%	1/10W
R145	1-216-864-11	SHORT CHIP	0		
R146	1-216-864-11	SHORT CHIP	0		
R147	1-216-864-11	SHORT CHIP	0		
R148	1-216-864-11	SHORT CHIP	0		
R149	1-216-864-11	SHORT CHIP	0		
R150	1-216-864-11	SHORT CHIP	0		
R151	1-216-864-11	SHORT CHIP	0		
R153	1-216-857-11	METAL CHIP	1M	5%	1/10W
R154	1-216-857-11	METAL CHIP	1M	5%	1/10W
R155	1-216-805-11	METAL CHIP	47	5%	1/10W
R156	1-216-809-11	METAL CHIP	100	5%	1/10W
R157	1-216-809-11	METAL CHIP	100	5%	1/10W
R201	1-216-295-91	SHORT CHIP	0		
R202	1-216-295-91	SHORT CHIP	0		
R203	1-216-809-11	METAL CHIP	100	5%	1/10W
R204	1-216-809-11	METAL CHIP	100	5%	1/10W
R205	1-216-809-11	METAL CHIP	100	5%	1/10W
R206	1-216-809-11	METAL CHIP	100	5%	1/10W
R207	1-216-809-11	METAL CHIP	100	5%	1/10W
R208	1-216-809-11	METAL CHIP	100	5%	1/10W
R209	1-216-809-11	METAL CHIP	100	5%	1/10W
R210	1-216-809-11	METAL CHIP	100	5%	1/10W
R211	1-216-809-11	METAL CHIP	100	5%	1/10W
R212	1-216-809-11	METAL CHIP	100	5%	1/10W
R218	1-216-845-11	METAL CHIP	100K	5%	1/10W
R219	1-216-845-11	METAL CHIP	100K	5%	1/10W
R220	1-216-845-11	METAL CHIP	100K	5%	1/10W
R221	1-216-845-11	METAL CHIP	100K	5%	1/10W
R222	1-216-845-11	METAL CHIP	100K	5%	1/10W
R223	1-216-845-11	METAL CHIP	100K	5%	1/10W
R301	1-216-845-11	METAL CHIP	100K	5%	1/10W
R302	1-216-864-11	SHORT CHIP	0		
R303	1-216-789-11	METAL CHIP	2.2	5%	1/10W
R304	1-216-789-11	METAL CHIP	2.2	5%	1/10W
R402	1-216-825-11	METAL CHIP	2.2K	5%	1/10W
R405	1-216-833-11	METAL CHIP	10K	5%	1/10W
R408	1-216-825-11	METAL CHIP	2.2K	5%	1/10W
R414	1-216-829-11	METAL CHIP	4.7K	5%	1/10W
R415	1-216-841-11	METAL CHIP	47K	5%	1/10W

Ref. No.	Part No.	Description			Remark
< VIBRATOR >					
X102	1-795-101-21	VIBRATOR, CERAMIC (16.9344MHz)			
*****					
	A-1508-439-A	MAIN BOARD, COMPLETE (UK)			
	A-1508-519-A	MAIN BOARD, COMPLETE (CND)			
	A-1508-544-A	MAIN BOARD, COMPLETE (AR, AUS)			
	A-1508-664-A	MAIN BOARD, COMPLETE (E51, SP)			
	A-1508-703-A	MAIN BOARD, COMPLETE (KR)			
	A-1508-735-A	MAIN BOARD, COMPLETE (MX, TW)			
	A-1542-780-A	MAIN BOARD, COMPLETE (RU)			
*****					
	7-685-646-79	SCREW +BVTP 3X8 TYPE2 N-S			
< BAND PASS FILTER >					
BPF801	1-236-711-21	FILTER, BAND PASS			
< CAPACITOR/RESISTOR >					
C101	1-128-549-11	ELECT	3300uF	20%	35V
C105	1-100-566-91	CERAMIC CHIP	0.1uF	10%	25V
					(UK, RU)
C105	1-117-863-11	CERAMIC CHIP	0.47uF	10%	6.3V
					(KR)
C109	1-162-970-11	CERAMIC CHIP	0.01uF	10%	25V
C110	1-115-467-11	CERAMIC CHIP	0.22uF	10%	10V
C111	1-164-156-11	CERAMIC CHIP	0.1uF		25V
C113	1-126-953-11	ELECT	2200uF	20%	35V
C114	1-100-566-91	CERAMIC CHIP	0.1uF	10%	25V
C115	1-164-156-11	CERAMIC CHIP	0.1uF		25V
C118	1-126-933-11	ELECT	100uF	20%	16V
C121	1-117-863-11	CERAMIC CHIP	0.47uF	10%	6.3V
C122	1-126-923-91	ELECT	220uF	20%	10V
C141	1-162-970-11	CERAMIC CHIP	0.01uF	10%	25V
C142	1-162-970-11	CERAMIC CHIP	0.01uF	10%	25V
C155	1-165-621-91	CERAMIC CHIP	0.1uF		50V
C156	1-165-621-91	CERAMIC CHIP	0.1uF		50V
C181	1-164-156-11	CERAMIC CHIP	0.1uF		25V
C182	1-164-156-11	CERAMIC CHIP	0.1uF		25V
C183	1-164-156-11	CERAMIC CHIP	0.1uF		25V
C184	1-164-156-11	CERAMIC CHIP	0.1uF		25V
C187	1-216-829-11	METAL CHIP	4.7K	5%	1/10W
C188	1-216-829-11	METAL CHIP	4.7K	5%	1/10W
C189	1-100-566-91	CERAMIC CHIP	0.1uF	10%	25V
C190	1-126-964-11	ELECT	10uF	20%	50V
C191	1-100-566-91	CERAMIC CHIP	0.1uF	10%	25V
C192	1-100-566-91	CERAMIC CHIP	0.1uF	10%	25V
C193	1-100-566-91	CERAMIC CHIP	0.1uF	10%	25V
C194	1-100-566-91	CERAMIC CHIP	0.1uF	10%	25V
C196	1-100-566-91	CERAMIC CHIP	0.1uF	10%	25V
C197	1-100-566-91	CERAMIC CHIP	0.1uF	10%	25V
C198	1-100-566-91	CERAMIC CHIP	0.1uF	10%	25V
C199	1-126-923-91	ELECT	220uF	20%	10V
C301	1-162-966-11	CERAMIC CHIP	0.0022uF	10%	50V
C302	1-162-964-11	CERAMIC CHIP	0.001uF	10%	50V
C303	1-126-963-11	ELECT	4.7uF	20%	50V
C304	1-126-933-11	ELECT	100uF	20%	16V
C305	1-126-960-11	ELECT	1uF	20%	50V
C306	1-126-960-11	ELECT	1uF	20%	50V
C307	1-126-767-11	ELECT	1000uF	20%	16V
C308	1-126-767-11	ELECT	1000uF	20%	16V



Ref. No.	Part No.	Description	Remark	Ref. No.	Part No.	Description	Remark
C309	1-162-964-11	CERAMIC CHIP	0.001uF 10% 50V	C544	1-162-964-11	CERAMIC CHIP	0.001uF 10% 50V
C310	1-162-964-11	CERAMIC CHIP	0.001uF 10% 50V	C561	1-162-966-11	CERAMIC CHIP	0.0022uF 10% 50V
C311	1-162-962-11	CERAMIC CHIP	470PF 10% 50V	C562	1-162-966-11	CERAMIC CHIP	0.0022uF 10% 50V
C312	1-162-962-11	CERAMIC CHIP	470PF 10% 50V	C564	1-162-970-11	CERAMIC CHIP	0.01uF 10% 25V
C315	1-162-964-11	CERAMIC CHIP	0.001uF 10% 50V	C565	1-115-156-11	CERAMIC CHIP	1uF 10V
C371	1-164-156-11	CERAMIC CHIP	0.1uF 25V	C567	1-130-479-00	MYLAR	0.0047uF 5% 50V
C381	1-162-964-11	CERAMIC CHIP	0.001uF 10% 50V	C800	1-164-156-11	CERAMIC CHIP	0.1uF 25V
C382	1-162-970-11	CERAMIC CHIP	0.01uF 10% 25V	C801	1-126-933-11	ELECT	100uF 20% 16V
C401	1-126-956-91	ELECT	0.1uF 20% 50V	C802	1-100-566-91	CERAMIC CHIP	0.1uF 10% 25V
C402	1-126-933-11	ELECT	100uF 20% 16V	C803	1-162-970-11	CERAMIC CHIP	0.01uF 10% 25V
C403	1-100-566-91	CERAMIC CHIP	0.1uF 10% 25V	C804	1-100-566-91	CERAMIC CHIP	0.1uF 10% 25V
C404	1-115-467-11	CERAMIC CHIP	0.22uF 10% 10V	C806	1-162-964-11	CERAMIC CHIP	0.001uF 10% 50V
C405	1-126-956-91	ELECT	0.1uF 20% 50V	C807	1-162-966-11	CERAMIC CHIP	0.0022uF 10% 50V
C406	1-115-467-11	CERAMIC CHIP	0.22uF 10% 10V	C809	1-100-566-91	CERAMIC CHIP	0.1uF 10% 25V
C407	1-162-968-11	CERAMIC CHIP	0.0047uF 10% 50V	C810	1-115-467-11	CERAMIC CHIP	0.22uF 10% 10V
C408	1-162-968-11	CERAMIC CHIP	0.0047uF 10% 50V	C811	1-164-156-11	CERAMIC CHIP	0.1uF 25V
C409	1-100-566-91	CERAMIC CHIP	0.1uF 10% 25V	C812	1-164-156-11	CERAMIC CHIP	0.1uF 25V
C410	1-100-566-91	CERAMIC CHIP	0.1uF 10% 25V	C813	1-126-923-91	ELECT	220uF 20% 10V
C412	1-126-933-11	ELECT	100uF 20% 16V	C814	1-164-156-11	CERAMIC CHIP	0.1uF 25V
C413	1-126-933-11	ELECT	100uF 20% 16V	C815	1-162-927-11	CERAMIC CHIP	100PF 5% 50V
C415	1-100-566-91	CERAMIC CHIP	0.1uF 10% 25V	C816	1-115-467-11	CERAMIC CHIP	0.22uF 10% 10V
C416	1-100-566-91	CERAMIC CHIP	0.1uF 10% 25V	C817	1-100-566-91	CERAMIC CHIP	0.1uF 10% 25V
C421	1-100-566-91	CERAMIC CHIP	0.1uF 10% 25V	C818	1-216-864-11	SHORT CHIP	0
C431	1-126-960-11	ELECT	1uF 20% 50V	C819	1-162-964-11	CERAMIC CHIP	0.001uF 10% 50V
C432	1-126-960-11	ELECT	1uF 20% 50V	C820	1-162-964-11	CERAMIC CHIP	0.001uF 10% 50V
C433	1-162-962-11	CERAMIC CHIP	470PF 10% 50V	C821	1-165-176-11	CERAMIC CHIP	0.047uF 10% 16V
C434	1-162-962-11	CERAMIC CHIP	470PF 10% 50V	C822	1-162-962-11	CERAMIC CHIP	470PF 10% 50V
C437	1-162-962-11	CERAMIC CHIP	470PF 10% 50V	C823	1-162-918-11	CERAMIC CHIP	18PF 5% 50V
C438	1-162-962-11	CERAMIC CHIP	470PF 10% 50V	C824	1-162-918-11	CERAMIC CHIP	18PF 5% 50V
C501	1-162-923-11	CERAMIC CHIP	47PF 5% 50V	C825	1-125-837-91	CERAMIC CHIP	1uF 10% 6.3V
C502	1-162-923-11	CERAMIC CHIP	47PF 5% 50V	C826	1-162-927-11	CERAMIC CHIP	100PF 5% 50V
C503	1-162-962-11	CERAMIC CHIP	470PF 10% 50V	C827	1-162-927-11	CERAMIC CHIP	100PF 5% 50V
C504	1-162-962-11	CERAMIC CHIP	470PF 10% 50V	C828	1-162-927-11	CERAMIC CHIP	100PF 5% 50V
C505	1-165-176-11	CERAMIC CHIP	0.047uF 10% 16V	C829	1-162-970-11	CERAMIC CHIP	0.01uF 10% 25V
C506	1-165-176-11	CERAMIC CHIP	0.047uF 10% 16V	C830	1-162-970-11	CERAMIC CHIP	0.01uF 10% 25V
C507	1-162-970-11	CERAMIC CHIP	0.01uF 10% 25V	C831	1-117-863-11	CERAMIC CHIP	0.47uF 10% 6.3V
C508	1-162-970-11	CERAMIC CHIP	0.01uF 10% 25V	C832	1-117-863-11	CERAMIC CHIP	0.47uF 10% 6.3V
C509	1-126-966-11	ELECT	33uF 20% 50V	C833	1-117-863-11	CERAMIC CHIP	0.47uF 10% 6.3V
C510	1-126-966-11	ELECT	33uF 20% 50V	C834	1-126-923-91	ELECT	220uF 20% 10V
C511	1-162-962-11	CERAMIC CHIP	470PF 10% 50V	C835	1-115-467-11	CERAMIC CHIP	0.22uF 10% 10V
C512	1-162-962-11	CERAMIC CHIP	470PF 10% 50V	C836	1-115-467-11	CERAMIC CHIP	0.22uF 10% 10V
C513	1-162-964-11	CERAMIC CHIP	0.001uF 10% 50V	C838	1-100-566-91	CERAMIC CHIP	0.1uF 10% 25V
C514	1-162-964-11	CERAMIC CHIP	0.001uF 10% 50V	C839	1-100-566-91	CERAMIC CHIP	0.1uF 10% 25V
C515	1-162-923-11	CERAMIC CHIP	47PF 5% 50V	C840	1-117-863-11	CERAMIC CHIP	0.47uF 10% 6.3V
C518	1-164-156-11	CERAMIC CHIP	0.1uF 25V	C841	1-126-965-91	ELECT	22uF 20% 50V
C519	1-164-156-11	CERAMIC CHIP	0.1uF 25V	C843	1-162-960-11	CERAMIC CHIP	220PF 10% 50V
C522	1-162-927-11	CERAMIC CHIP	100PF 5% 50V	C847	1-162-968-11	CERAMIC CHIP	0.0047uF 10% 50V (EXCEPT UK, RU) (EXCEPT CND)
C523	1-162-970-11	CERAMIC CHIP	0.01uF 10% 25V	C847	1-162-970-11	CERAMIC CHIP	0.01uF 10% 25V (CND)
C524	1-162-970-11	CERAMIC CHIP	0.01uF 10% 25V	C848	1-162-968-11	CERAMIC CHIP	0.0047uF 10% 50V (EXCEPT CND)
C525	1-162-970-11	CERAMIC CHIP	0.01uF 10% 25V	C848	1-162-970-11	CERAMIC CHIP	0.01uF 10% 25V (CND)
C526	1-162-970-11	CERAMIC CHIP	0.01uF 10% 25V	C851	1-165-176-11	CERAMIC CHIP	0.047uF 10% 16V
C527	1-162-964-11	CERAMIC CHIP	0.001uF 10% 50V	C852	1-162-915-11	CERAMIC CHIP	10PF 0.5PF 50V
C528	1-162-964-11	CERAMIC CHIP	0.001uF 10% 50V	C853	1-164-227-11	CERAMIC CHIP	0.022uF 10% 25V
C529	1-162-927-11	CERAMIC CHIP	100PF 5% 50V	C854	1-162-915-11	CERAMIC CHIP	10PF 0.5PF 50V
C531	1-162-964-11	CERAMIC CHIP	0.001uF 10% 50V	C855	1-162-962-11	CERAMIC CHIP	470PF 10% 50V
C532	1-162-964-11	CERAMIC CHIP	0.001uF 10% 50V	C856	1-162-910-11	CERAMIC CHIP	5PF 0.25PF 50V
C533	1-100-566-91	CERAMIC CHIP	0.1uF 10% 25V				
C534	1-100-566-91	CERAMIC CHIP	0.1uF 10% 25V				
C535	1-100-566-91	CERAMIC CHIP	0.1uF 10% 25V				
C543	1-162-964-11	CERAMIC CHIP	0.001uF 10% 50V				

# HCD-EH15

## MAIN

Ref. No.	Part No.	Description	Remark	Ref. No.	Part No.	Description	Remark
C861	1-100-566-91	CERAMIC CHIP 0.1uF	10% 25V (UK)			< JACK/TERMINAL BOARD >	
C862	1-100-566-91	CERAMIC CHIP 0.1uF	10% 25V (UK)	J101	1-780-314-11	TERMINAL BOARD (SPEAKER)	
C863	1-126-965-91	ELECT 22uF	20% 50V (UK)	J102	1-815-629-11	JACK (PHONES)	
C864	1-162-962-11	CERAMIC CHIP 470PF	10% 50V (UK)	J105	1-566-822-51	JACK (AUDIO IN)	
C865	1-126-965-91	ELECT 22uF	20% 50V (UK)			< JUMPER RESISTOR >	
C866	1-162-962-11	CERAMIC CHIP 470PF	10% 50V (UK)				
C867	1-162-962-11	CERAMIC CHIP 470PF	10% 50V (UK)	JR101	1-216-864-11	SHORT CHIP 0 (KR)	
C868	1-162-925-11	CERAMIC CHIP 68PF	5% 50V (UK)	JR102	1-216-864-11	SHORT CHIP 0 (MX, TW)	
C869	1-162-923-11	CERAMIC CHIP 47PF	5% 50V (UK)	JR103	1-216-864-11	SHORT CHIP 0 (AR, AUS)	
C873	1-162-907-11	CERAMIC CHIP 2PF	0.25PF 50V	JR104	1-216-864-11	SHORT CHIP 0 (E51, SP)	
		< FILTER/CAPACITOR >		JR105	1-216-864-11	SHORT CHIP 0 (CND)	
CF801	1-795-426-11	FILTER, CERAMIC		JR106	1-216-864-11	SHORT CHIP 0 (UK)	
CF802	1-128-821-51	CERAMIC 1000PF	5% 50V (EXCEPT UK, RU)	JR107	1-216-864-11	SHORT CHIP 0 (RU)	
CF802	1-579-554-21	FILTER, CERAMIC (UK, RU)		JR401	1-216-864-11	SHORT CHIP 0	
CF803	1-781-962-21	FILTER, CERAMIC		JR402	1-216-864-11	SHORT CHIP 0	
		< CONNECTOR >		JR403	1-216-864-11	SHORT CHIP 0	
CN105	1-784-778-11	CONNECTOR, FFC 17P		JR404	1-216-864-11	SHORT CHIP 0	
CN106	1-784-766-11	CONNECTOR, FFC 5P (EXCEPT UK)		JR801	1-216-864-11	SHORT CHIP 0	
CN106	1-568-826-11	CONNECTOR, FFC 7P (UK)		JR802	1-216-864-11	SHORT CHIP 0	
CNP501	1-815-445-11	PIN, CONNECTOR (PWB) 4P		JR803	1-216-864-11	SHORT CHIP 0	
CNP502	1-815-444-11	PIN, CONNECTOR (PWB) 3P		JR861	1-216-864-11	SHORT CHIP 0 (UK)	
* CNP802	1-506-680-11	PLUG, CONNECTOR (2.5mm) 3P (ANTENNA FM/AM)				< RESISTOR >	
		< DIODE >		JW137	1-249-385-11	CARBON 2.2 5% 1/4W (CND)	
D106	6-501-172-01	DIODE UDZW-TE17-8.2B				< COIL/FERRITE BEAD >	
D107	6-502-411-01	DIODE RL202-B322-1		L103	1-469-152-11	FERRITE, EMI (SMD) (2012)	
D108	6-502-411-01	DIODE RL202-B322-1		L104	1-410-509-11	INDUCTOR 10uH	
D109	6-502-411-01	DIODE RL202-B322-1		L501	1-456-094-11	TRANSFORMER, BIAS OSCILLATION	
D110	6-502-411-01	DIODE RL202-B322-1		L803	1-433-741-11	TRANSFORMER, IF	
D111	6-501-582-01	DIODE 1N4002-B5		L804	1-457-163-22	COIL, AIR-CORE	
D112	6-501-582-01	DIODE 1N4002-B5 (E51, SP)		L805	1-457-162-22	COIL, AIR-CORE	
D113	6-501-582-01	DIODE 1N4002-B5		L806	1-457-168-11	COIL, DET	
D114	6-501-582-01	DIODE 1N4002-B5 (E51, SP)		L851	1-457-161-11	COIL, AM ANTENNA	
D131	6-500-334-01	DIODE MC2836-T112-1		L852	1-456-596-11	COIL, MW OSC	
D193	6-500-335-01	DIODE MC2838-T112-1				< TRANSISTOR >	
D371	6-500-335-01	DIODE MC2838-T112-1		Q101	8-729-024-93	TRANSISTOR 2SB1565E	
D372	6-500-335-01	DIODE MC2838-T112-1		Q102	8-729-120-28	TRANSISTOR 2SC1623-L5L6	
D802	6-501-369-01	DIODE SVC230-TB-E		Q103	8-729-120-28	TRANSISTOR 2SC1623-L5L6	
D803	6-501-369-01	DIODE SVC230-TB-E		Q121	8-729-120-28	TRANSISTOR 2SC1623-L5L6	
D812	6-501-579-01	DIODE MC2837		Q122	8-729-120-28	TRANSISTOR 2SC1623-L5L6	
D813	6-501-579-01	DIODE MC2837		Q123	8-729-120-28	TRANSISTOR 2SC1623-L5L6	
D815	6-501-579-01	DIODE MC2837		Q191	8-729-036-86	TRANSISTOR KTC3203Y-AT	
D851	6-501-142-01	DIODE SVC347A-TL-E		Q192	8-729-036-86	TRANSISTOR KTC3203Y-AT	
		< FERRITE BEAD >		Q193	6-551-696-01	TRANSISTOR ISA1235AC1TP-1EF	
FB101	1-469-152-11	FERRITE, EMI (SMD) (2012)		Q194	8-729-037-13	TRANSISTOR KTA1271Y	
FB102	1-469-152-11	FERRITE, EMI (SMD) (2012)		Q195	8-729-120-28	TRANSISTOR 2SC1623-L5L6	
FB103	1-469-152-11	FERRITE, EMI (SMD) (2012)		Q351	6-551-703-01	FET 2SJ599-ZK-E1-AZ	
		< IC >		Q352	8-729-120-28	TRANSISTOR 2SC1623-L5L6	
IC101	6-710-863-01	IC TK70540SCL-G		Q371	6-551-696-01	TRANSISTOR ISA1235AC1TP-1EF	
IC301	6-706-641-01	IC LA4631-E		Q372	8-729-120-28	TRANSISTOR 2SC1623-L5L6	
IC401	6-702-895-01	IC BD3881FV		Q507	8-729-120-28	TRANSISTOR 2SC1623-L5L6	
IC801	6-708-840-01	IC LV23003VA		Q801	8-729-120-28	TRANSISTOR 2SC1623-L5L6	
IC861	6-708-918-01	IC PT2579SN (UK)		Q802	8-729-120-28	TRANSISTOR 2SC1623-L5L6	
				Q803	6-550-304-01	TRANSISTOR 2SC5477-T122-1	
				Q861	8-729-120-28	TRANSISTOR 2SC1623-L5L6 (UK)	
				Q862	8-729-120-28	TRANSISTOR 2SC1623-L5L6 (UK)	

Ref. No.	Part No.	Description	Remark	Ref. No.	Part No.	Description	Remark
		< RESISTOR >		R340	1-216-809-11	METAL CHIP	100 5% 1/10W
R101	1-216-833-11	METAL CHIP	10K 5% 1/10W	R351	1-216-833-11	METAL CHIP	10K 5% 1/10W
R102	1-216-809-11	METAL CHIP	100 5% 1/10W	R352	1-216-825-11	METAL CHIP	2.2K 5% 1/10W
R103	1-216-841-11	METAL CHIP	47K 5% 1/10W	R353	1-216-833-11	METAL CHIP	10K 5% 1/10W
R104	1-216-845-11	METAL CHIP	100K 5% 1/10W	R354	1-216-833-11	METAL CHIP	10K 5% 1/10W
R105	1-216-845-11	METAL CHIP	100K 5% 1/10W	R355	1-216-833-11	METAL CHIP	10K 5% 1/10W
R106	1-216-836-11	METAL CHIP	18K 5% 1/10W	R356	1-216-837-11	METAL CHIP	22K 5% 1/10W
R107	1-216-817-11	METAL CHIP	470 5% 1/10W	R365	1-216-825-11	METAL CHIP	2.2K 5% 1/10W
R108	1-216-809-11	METAL CHIP	100 5% 1/10W	R371	1-218-446-11	METAL CHIP	1 5% 1/10W
R109	1-216-817-11	METAL CHIP	470 5% 1/10W	R372	1-218-446-11	METAL CHIP	1 5% 1/10W
R110	1-216-845-11	METAL CHIP	100K 5% 1/10W	R373	1-218-446-11	METAL CHIP	1 5% 1/10W
R111	1-216-853-11	METAL CHIP	470K 5% 1/10W	R374	1-218-446-11	METAL CHIP	1 5% 1/10W
R112	1-216-853-11	METAL CHIP	470K 5% 1/10W	R375	1-218-446-11	METAL CHIP	1 5% 1/10W
R113	1-216-829-11	METAL CHIP	4.7K 5% 1/10W	R376	1-218-446-11	METAL CHIP	1 5% 1/10W
R114	1-216-829-11	METAL CHIP	4.7K 5% 1/10W	R377	1-218-446-11	METAL CHIP	1 5% 1/10W
R115	1-249-409-11	CARBON	220 5% 1/4W	R378	1-218-446-11	METAL CHIP	1 5% 1/10W
R116	1-249-409-11	CARBON	220 5% 1/4W	R379	1-218-446-11	METAL CHIP	1 5% 1/10W
R117	1-249-409-11	CARBON	220 5% 1/4W	R380	1-218-446-11	METAL CHIP	1 5% 1/10W
R118	1-249-409-11	CARBON	220 5% 1/4W	R381	1-216-833-11	METAL CHIP	10K 5% 1/10W
R119	1-216-825-11	METAL CHIP	2.2K 5% 1/10W	R382	1-216-833-11	METAL CHIP	10K 5% 1/10W
R120	1-216-825-11	METAL CHIP	2.2K 5% 1/10W	R383	1-216-833-11	METAL CHIP	10K 5% 1/10W
R121	1-216-849-11	METAL CHIP	220K 5% 1/10W	R384	1-216-821-11	METAL CHIP	1K 5% 1/10W
R123	1-216-853-11	METAL CHIP	470K 5% 1/10W	R402	1-216-809-11	METAL CHIP	100 5% 1/10W
R124	1-216-809-11	METAL CHIP	100 5% 1/10W	R403	1-216-821-11	METAL CHIP	1K 5% 1/10W
R125	1-216-829-11	METAL CHIP	4.7K 5% 1/10W	R404	1-216-813-11	METAL CHIP	220 5% 1/10W
R126	1-216-841-11	METAL CHIP	47K 5% 1/10W	R405	1-216-864-11	SHORT CHIP	0
R127	1-216-841-11	METAL CHIP	47K 5% 1/10W	R406	1-216-821-11	METAL CHIP	1K 5% 1/10W
R128	1-216-813-11	METAL CHIP	220 5% 1/10W	R410	1-216-845-11	METAL CHIP	100K 5% 1/10W
R129	1-216-813-11	METAL CHIP	220 5% 1/10W	R411	1-216-821-11	METAL CHIP	1K 5% 1/10W
R130	1-216-813-11	METAL CHIP	220 5% 1/10W	R412	1-216-813-11	METAL CHIP	220 5% 1/10W
R131	1-216-813-11	METAL CHIP	220 5% 1/10W	R419	1-216-839-11	METAL CHIP	33K 5% 1/10W
R151	1-216-833-11	METAL CHIP	10K 5% 1/10W	R420	1-216-839-11	METAL CHIP	33K 5% 1/10W
R152	1-216-833-11	METAL CHIP	10K 5% 1/10W	R423	1-216-829-11	METAL CHIP	4.7K 5% 1/10W
R175	1-216-845-11	METAL CHIP	100K 5% 1/10W	R424	1-216-829-11	METAL CHIP	4.7K 5% 1/10W
R176	1-216-845-11	METAL CHIP	100K 5% 1/10W	R425	1-216-829-11	METAL CHIP	4.7K 5% 1/10W
R177	1-216-845-11	METAL CHIP	100K 5% 1/10W	R426	1-216-829-11	METAL CHIP	4.7K 5% 1/10W
R178	1-216-833-11	METAL CHIP	10K 5% 1/10W	R427	1-216-845-11	METAL CHIP	100K 5% 1/10W
R179	1-216-833-11	METAL CHIP	10K 5% 1/10W	R428	1-216-845-11	METAL CHIP	100K 5% 1/10W
R181	1-216-797-11	METAL CHIP	10 5% 1/10W	R429	1-216-829-11	METAL CHIP	4.7K 5% 1/10W
R182	1-216-797-11	METAL CHIP	10 5% 1/10W	R430	1-216-829-11	METAL CHIP	4.7K 5% 1/10W
R185	1-247-807-31	CARBON	100 5% 1/4W	R433	1-216-837-11	METAL CHIP	22K 5% 1/10W
R186	1-247-807-31	CARBON	100 5% 1/4W	R434	1-216-837-11	METAL CHIP	22K 5% 1/10W
R187	1-247-807-31	CARBON	100 5% 1/4W	R439	1-216-829-11	METAL CHIP	4.7K 5% 1/10W
R188	1-216-837-11	METAL CHIP	22K 5% 1/10W	R440	1-216-829-11	METAL CHIP	4.7K 5% 1/10W
R189	1-216-837-11	METAL CHIP	22K 5% 1/10W	R441	1-216-841-11	METAL CHIP	47K 5% 1/10W
R192	1-216-845-11	METAL CHIP	100K 5% 1/10W	R442	1-216-841-11	METAL CHIP	47K 5% 1/10W
R195	1-216-809-11	METAL CHIP	100 5% 1/10W	R501	1-216-809-11	METAL CHIP	100 5% 1/10W
R196	1-216-809-11	METAL CHIP	100 5% 1/10W	R502	1-216-809-11	METAL CHIP	100 5% 1/10W
R197	1-247-807-31	CARBON	100 5% 1/4W	R503	1-216-829-11	METAL CHIP	4.7K 5% 1/10W
R198	1-247-807-31	CARBON	100 5% 1/4W	R504	1-216-829-11	METAL CHIP	4.7K 5% 1/10W
R199	1-247-807-31	CARBON	100 5% 1/4W	R505	1-216-833-11	METAL CHIP	10K 5% 1/10W
R301	1-216-837-11	METAL CHIP	22K 5% 1/10W	R506	1-216-833-11	METAL CHIP	10K 5% 1/10W
R302	1-216-837-11	METAL CHIP	22K 5% 1/10W	R507	1-216-825-11	METAL CHIP	2.2K 5% 1/10W
R303	1-216-825-11	METAL CHIP	2.2K 5% 1/10W	R508	1-216-825-11	METAL CHIP	2.2K 5% 1/10W
R304	1-216-825-11	METAL CHIP	2.2K 5% 1/10W	R509	1-216-853-11	METAL CHIP	470K 5% 1/10W
R305	1-216-829-11	METAL CHIP	4.7K 5% 1/10W	R510	1-216-853-11	METAL CHIP	470K 5% 1/10W
R306	1-216-829-11	METAL CHIP	4.7K 5% 1/10W	R511	1-216-861-11	METAL CHIP	2.2M 5% 1/10W
R307	1-216-837-11	METAL CHIP	22K 5% 1/10W	R512	1-216-861-11	METAL CHIP	2.2M 5% 1/10W
R308	1-216-837-11	METAL CHIP	22K 5% 1/10W	R513	1-216-809-11	METAL CHIP	100 5% 1/10W
R339	1-216-809-11	METAL CHIP	100 5% 1/10W	R514	1-216-809-11	METAL CHIP	100 5% 1/10W

# HCD-EH15

## MAIN

Ref. No.	Part No.	Description	Quantity	Unit	Percentage	Remark	Ref. No.	Part No.	Description	Quantity	Unit	Percentage	Remark
R515	1-216-805-11	METAL CHIP	47		5%	1/10W	R828	1-216-805-11	METAL CHIP	47		5%	1/10W
R516	1-216-805-11	METAL CHIP	47		5%	1/10W							(EXCEPT UK, RU)
R517	1-216-845-11	METAL CHIP	100K		5%	1/10W	R829	1-216-845-11	METAL CHIP	100K		5%	1/10W
R518	1-216-845-11	METAL CHIP	100K		5%	1/10W	R830	1-216-841-11	METAL CHIP	47K		5%	1/10W
R519	1-216-839-11	METAL CHIP	33K		5%	1/10W	R831	1-216-813-11	METAL CHIP	220		5%	1/10W
R520	1-216-839-11	METAL CHIP	33K		5%	1/10W	R833	1-216-833-11	METAL CHIP	10K		5%	1/10W
R521	1-216-837-11	METAL CHIP	22K		5%	1/10W	R834	1-216-837-11	METAL CHIP	22K		5%	1/10W
R522	1-216-837-11	METAL CHIP	22K		5%	1/10W	R835	1-216-829-11	METAL CHIP	4.7K		5%	1/10W
R523	1-216-829-11	METAL CHIP	4.7K		5%	1/10W	R836	1-216-833-11	METAL CHIP	10K		5%	1/10W
R524	1-216-829-11	METAL CHIP	4.7K		5%	1/10W	R837	1-216-821-11	METAL CHIP	1K		5%	1/10W
R525	1-216-833-11	METAL CHIP	10K		5%	1/10W	R838	1-216-821-11	METAL CHIP	1K		5%	1/10W
R526	1-216-833-11	METAL CHIP	10K		5%	1/10W	R839	1-216-809-11	METAL CHIP	100		5%	1/10W
R527	1-216-829-11	METAL CHIP	4.7K		5%	1/10W	R840	1-216-837-11	METAL CHIP	22K		5%	1/10W
R528	1-216-829-11	METAL CHIP	4.7K		5%	1/10W	R841	1-216-809-11	METAL CHIP	100		5%	1/10W
R529	1-216-825-11	METAL CHIP	2.2K		5%	1/10W	R842	1-216-841-11	METAL CHIP	47K		5%	1/10W
R530	1-216-825-11	METAL CHIP	2.2K		5%	1/10W	R843	1-216-853-11	METAL CHIP	470K		5%	1/10W
R531	1-216-829-11	METAL CHIP	4.7K		5%	1/10W	R844	1-216-797-11	METAL CHIP	10		5%	1/10W
R532	1-216-829-11	METAL CHIP	4.7K		5%	1/10W	R845	1-216-801-11	METAL CHIP	22		5%	1/10W
R533	1-216-833-11	METAL CHIP	10K		5%	1/10W	R846	1-216-825-11	METAL CHIP	2.2K		5%	1/10W
R534	1-216-833-11	METAL CHIP	10K		5%	1/10W	R847	1-216-801-11	METAL CHIP	22		5%	1/10W
R535	1-216-813-11	METAL CHIP	220		5%	1/10W	R848	1-216-821-11	METAL CHIP	1K		5%	1/10W
R536	1-216-813-11	METAL CHIP	220		5%	1/10W	R849	1-216-837-11	METAL CHIP	22K		5%	1/10W
R541	1-216-837-11	METAL CHIP	22K		5%	1/10W	R850	1-216-825-11	METAL CHIP	2.2K		5%	1/10W
R542	1-216-833-11	METAL CHIP	10K		5%	1/10W	R851	1-216-837-11	METAL CHIP	22K		5%	1/10W
R543	1-216-829-11	METAL CHIP	4.7K		5%	1/10W	R853	1-216-845-11	METAL CHIP	100K		5%	1/10W
R544	1-216-829-11	METAL CHIP	4.7K		5%	1/10W	R856	1-216-837-11	METAL CHIP	22K		5%	1/10W
R545	1-216-829-11	METAL CHIP	4.7K		5%	1/10W							(UK)
R560	1-216-821-11	METAL CHIP	1K		5%	1/10W	R857	1-216-837-11	METAL CHIP	22K		5%	1/10W
R561	1-216-837-11	METAL CHIP	22K		5%	1/10W							(UK)
R564	1-216-793-11	METAL CHIP	4.7		5%	1/10W	R859	1-216-821-11	METAL CHIP	1K		5%	1/10W
R565	1-216-793-11	METAL CHIP	4.7		5%	1/10W							(UK, RU)
R801	1-216-825-11	METAL CHIP	2.2K		5%	1/10W	R859	1-216-837-11	METAL CHIP	22K		5%	1/10W
R802	1-216-797-11	METAL CHIP	10		5%	1/10W							(EXCEPT UK, RU)
R803	1-216-797-11	METAL CHIP	10		5%	1/10W	R860	1-216-821-11	METAL CHIP	1K		5%	1/10W
R804	1-216-864-11	SHORT CHIP	0										(UK, RU)
R805	1-216-845-11	METAL CHIP	100K		5%	1/10W	R860	1-216-837-11	METAL CHIP	22K		5%	1/10W
R806	1-216-864-11	SHORT CHIP	0										(EXCEPT UK, RU)
R807	1-216-845-11	METAL CHIP	100K		5%	1/10W	R861	1-216-833-11	METAL CHIP	10K		5%	1/10W
R808	1-216-833-11	METAL CHIP	10K		5%	1/10W							(UK)
R809	1-216-821-11	METAL CHIP	1K		5%	1/10W	R862	1-216-817-11	METAL CHIP	470		5%	1/10W
R810	1-216-857-11	METAL CHIP	1M		5%	1/10W							(UK)
R811	1-216-829-11	METAL CHIP	4.7K		5%	1/10W	R863	1-216-837-11	METAL CHIP	22K		5%	1/10W
R812	1-216-817-11	METAL CHIP	470		5%	1/10W	R864	1-216-833-11	METAL CHIP	10K		5%	1/10W
R813	1-216-833-11	METAL CHIP	10K		5%	1/10W							(UK)
R814	1-216-809-11	METAL CHIP	100		5%	1/10W	R865	1-216-833-11	METAL CHIP	10K		5%	1/10W
R815	1-216-829-11	METAL CHIP	4.7K		5%	1/10W							(UK)
R816	1-216-833-11	METAL CHIP	10K		5%	1/10W	R866	1-216-833-11	METAL CHIP	10K		5%	1/10W
R817	1-216-833-11	METAL CHIP	10K		5%	1/10W							(UK)
R818	1-216-841-11	METAL CHIP	47K		5%	1/10W	R867	1-216-833-11	METAL CHIP	10K		5%	1/10W
R819	1-216-841-11	METAL CHIP	47K		5%	1/10W							(UK)
R820	1-216-833-11	METAL CHIP	10K		5%	1/10W	R868	1-216-833-11	METAL CHIP	10K		5%	1/10W
R821	1-216-813-11	METAL CHIP	220		5%	1/10W							(UK)
R822	1-216-825-11	METAL CHIP	2.2K		5%	1/10W	R869	1-216-833-11	METAL CHIP	10K		5%	1/10W
R823	1-216-809-11	METAL CHIP	100		5%	1/10W							(UK)
R824	1-216-825-11	METAL CHIP	2.2K		5%	1/10W	R870	1-216-853-11	METAL CHIP	470K		5%	1/10W
R825	1-216-817-11	METAL CHIP	470		5%	1/10W							(UK)
R826	1-216-809-11	METAL CHIP	100		5%	1/10W	R871	1-216-849-11	METAL CHIP	220K		5%	1/10W
R827	1-216-809-11	METAL CHIP	100		5%	1/10W							(UK)
R828	1-216-801-11	METAL CHIP	22		5%	1/10W	R872	1-216-813-11	METAL CHIP	220		5%	1/10W
						(UK, RU)							(UK)
							R873	1-216-825-11	METAL CHIP	2.2K		5%	1/10W
													(UK)
							R874	1-216-845-11	METAL CHIP	100K		5%	1/10W
													(UK)

Ref. No.	Part No.	Description	Remark	Ref. No.	Part No.	Description	Remark
R875	1-216-845-11	METAL CHIP	100K 5% 1/10W (UK)			< IC >	
R876	1-216-841-11	METAL CHIP	47K 5% 1/10W (UK)	IC701	A-1545-973-A	IC MB90F830PF-GE1 (for SERVICE)	
				IC703	6-600-349-31	IC NJL24H400A	
		< SWITCH >				< JUMPER RESISTOR >	
SW501	1-762-369-11	SWITCH, SLIDE (REC/PB)		JR704	1-216-864-11	SHORT CHIP	0
		< VIBRATOR >		JR705	1-216-864-11	SHORT CHIP	0
X801	1-767-388-21	VIBRATOR, CRYSTAL (75kHz) (EXCEPT UK, RU)		JR706	1-216-864-11	SHORT CHIP	0
X801	1-795-926-11	VIBRATOR, CRYSTAL (75kHz) (UK, RU)		JR707	1-216-864-11	SHORT CHIP	0
X861	1-579-900-21	VIBRATOR, CRYSTAL (4.332MHz) (UK)		JR708	1-216-864-11	SHORT CHIP	0
*****							
	A-1508-455-A	PANEL BOARD, COMPLETE (UK)		JR709	1-216-864-11	SHORT CHIP	0
	A-1508-530-A	PANEL BOARD, COMPLETE (CND)		JR710	1-216-864-11	SHORT CHIP	0
	A-1508-558-A	PANEL BOARD, COMPLETE (SP, TW, KR)		JR713	1-216-864-11	SHORT CHIP	0
	A-1508-593-A	PANEL BOARD, COMPLETE (E51, MX, AR)		JR714	1-216-864-11	SHORT CHIP	0
	A-1527-693-A	PANEL BOARD, COMPLETE (AUS)		JR719	1-216-864-11	SHORT CHIP	0
	A-1542-781-A	PANEL BOARD, COMPLETE (RU)	*****	JR722	1-216-864-11	SHORT CHIP	0
	2-636-531-01	HOLDER (LCD)		JR723	1-216-864-11	SHORT CHIP	0
	2-636-532-01	ILLUMINATOR (LCD)		JR724	1-216-864-11	SHORT CHIP	0
	2-636-545-01	SHEET (LCD)		JR743	1-216-864-11	SHORT CHIP	0
		< CAPACITOR >		JR744	1-216-864-11	SHORT CHIP	0
C701	1-164-156-11	CERAMIC CHIP	0.1uF 25V	JR747	1-216-864-11	SHORT CHIP	0
C702	1-162-970-11	CERAMIC CHIP	0.01uF 10% 25V	JR748	1-216-864-11	SHORT CHIP	0
C704	1-126-518-11	ELECT	470uF 20% 4V	JR749	1-216-864-11	SHORT CHIP	0
C706	1-164-156-11	CERAMIC CHIP	0.1uF 25V	JR750	1-216-864-11	SHORT CHIP	0
C707	1-162-964-11	CERAMIC CHIP	0.001uF 10% 50V	JR751	1-216-864-11	SHORT CHIP	0
C710	1-165-908-11	CERAMIC CHIP	1uF 10% 10V	JR752	1-216-864-11	SHORT CHIP	0
C711	1-164-156-11	CERAMIC CHIP	0.1uF 25V	JR755	1-216-864-11	SHORT CHIP	0
C712	1-164-156-11	CERAMIC CHIP	0.1uF 25V	JR756	1-216-864-11	SHORT CHIP	0
C716	1-164-156-11	CERAMIC CHIP	0.1uF 25V	JR757	1-216-864-11	SHORT CHIP	0
C719	1-165-176-11	CERAMIC CHIP	0.047uF 10% 16V	JR760	1-216-864-11	SHORT CHIP	0
C721	1-162-971-11	CERAMIC CHIP	0.001uF 10% 50V	JR762	1-216-864-11	SHORT CHIP	0
C722	1-162-971-11	CERAMIC CHIP	0.001uF 10% 50V	JR763	1-216-864-11	SHORT CHIP	0
C723	1-162-971-11	CERAMIC CHIP	0.001uF 10% 50V	JR775	1-216-864-11	SHORT CHIP	0
C724	1-113-905-11	CERAMIC	220PF 10% 250V	JR788	1-216-864-11	SHORT CHIP	0
C725	1-126-382-11	ELECT	100uF 20% 16V	JR789	1-216-864-11	SHORT CHIP	0
C726	1-162-970-11	CERAMIC CHIP	0.01uF 10% 25V	L701	1-216-864-11	SHORT CHIP	0
C727	1-162-923-11	CERAMIC CHIP	47PF 5% 50V	L702	1-216-864-11	SHORT CHIP	0
C728	1-162-923-11	CERAMIC CHIP	47PF 5% 50V			< LIQUID CRYSTAL DISPLAY >	
C729	1-162-964-11	CERAMIC CHIP	0.001uF 10% 50V	LCD702	1-802-381-11	DISPLAY PANEL, LIQUID CRYSTAL	
C731	1-164-156-11	CERAMIC CHIP	0.1uF 25V			< LED >	
C732	1-162-918-11	CERAMIC CHIP	18PF 5% 50V	LED701	6-502-498-01	LED SELU2B10A-SLF62FGH	(LCD BACK LIGHT)
C733	1-162-919-11	CERAMIC CHIP	22PF 5% 50V	LED702	6-501-452-01	LED 1L4345V22DOTDT02 (STANDBY)	
		< CONNECTOR >				< TRANSISTOR >	
CNP701	1-779-289-11	CONNECTOR, FFC (LIF (NON-ZIF)) 21P		Q701	6-551-696-01	TRANSISTOR	ISA1235AC1TP-1EF
CNP703	1-784-727-11	CONNECTOR, FFC 5P (EXCEPT UK)		Q702	8-729-120-28	TRANSISTOR	2SC1623-L5L6
CNP703	1-568-850-11	CONNECTOR, FFC 7P (UK)		Q703	8-729-120-28	TRANSISTOR	2SC1623-L5L6
CNP706	1-784-778-11	CONNECTOR, FFC 17P		Q704	8-729-038-28	TRANSISTOR	RT1N441C-TP-1
		< DIODE >		Q705	8-729-120-28	TRANSISTOR	2SC1623-L5L6
D701	6-501-163-01	DIODE UDZW-TE17-3.6B		Q706	8-729-120-28	TRANSISTOR	2SC1623-L5L6
D702	6-500-334-01	DIODE MC2836-T112-1		Q707	8-729-120-28	TRANSISTOR	2SC1623-L5L6
D801	6-501-582-01	DIODE 1N4002-B5		Q713	8-729-038-28	TRANSISTOR	RT1N441C-TP-1
D804	6-501-582-01	DIODE 1N4002-B5		Q714	6-551-696-01	TRANSISTOR	ISA1235AC1TP-1EF
						< RESISTOR >	
				R701	1-216-817-11	METAL CHIP	470 5% 1/10W

## PANEL

Ref. No.	Part No.	Description	Remark	Ref. No.	Part No.	Description	Remark
R702	1-216-821-11	METAL CHIP	1K 5% 1/10W	R781	1-216-813-11	METAL CHIP	220 5% 1/10W (RU)
R703	1-216-821-11	METAL CHIP	1K 5% 1/10W	R781	1-216-817-11	METAL CHIP	470 5% 1/10W (E51, MX, AR)
R704	1-216-821-11	METAL CHIP	1K 5% 1/10W	R781	1-216-821-11	METAL CHIP	1K 5% 1/10W (CND)
R705	1-216-821-11	METAL CHIP	1K 5% 1/10W	R781	1-216-829-11	METAL CHIP	4.7K 5% 1/10W (AUS)
R706	1-216-821-11	METAL CHIP	1K 5% 1/10W	R781	1-216-864-11	SHORT CHIP	0 (UK)
R707	1-216-821-11	METAL CHIP	1K 5% 1/10W	R782	1-216-829-11	METAL CHIP	4.7K 5% 1/10W (CND, E51, MX, AR, AUS, RU)
R708	1-216-821-11	METAL CHIP	1K 5% 1/10W	R782	1-216-864-11	SHORT CHIP	0 (SP, TW, KR)
R709	1-216-821-11	METAL CHIP	1K 5% 1/10W	R783	1-216-864-11	SHORT CHIP	0 (EXCEPT UK)
R710	1-216-821-11	METAL CHIP	1K 5% 1/10W	R784	1-216-845-11	METAL CHIP	100K 5% 1/10W
R711	1-216-821-11	METAL CHIP	1K 5% 1/10W	R785	1-216-833-11	METAL CHIP	10K 5% 1/10W
R713	1-216-833-11	METAL CHIP	10K 5% 1/10W	R787	1-216-841-11	METAL CHIP	47K 5% 1/10W
R714	1-216-833-11	METAL CHIP	10K 5% 1/10W	R788	1-216-821-11	METAL CHIP	1K 5% 1/10W
R718	1-216-821-11	METAL CHIP	1K 5% 1/10W	R789	1-216-821-11	METAL CHIP	1K 5% 1/10W
R719	1-216-821-11	METAL CHIP	1K 5% 1/10W	R790	1-216-821-11	METAL CHIP	1K 5% 1/10W
R720	1-216-821-11	METAL CHIP	1K 5% 1/10W	R791	1-216-821-11	METAL CHIP	1K 5% 1/10W
R721	1-216-817-11	METAL CHIP	470 5% 1/10W	R792	1-216-833-11	METAL CHIP	10K 5% 1/10W
R722	1-216-821-11	METAL CHIP	1K 5% 1/10W	R793	1-216-833-11	METAL CHIP	10K 5% 1/10W
R723	1-216-817-11	METAL CHIP	470 5% 1/10W	R798	1-216-841-11	METAL CHIP	47K 5% 1/10W
R727	1-216-821-11	METAL CHIP	1K 5% 1/10W	R799	1-216-845-11	METAL CHIP	100K 5% 1/10W
R728	1-216-833-11	METAL CHIP	10K 5% 1/10W	< SWITCH >			
R730	1-216-821-11	METAL CHIP	1K 5% 1/10W	SW700	1-478-642-11	ENCODER, ROTARY (VOLUME)	
R732	1-216-841-11	METAL CHIP	47K 5% 1/10W	SW701	1-762-875-21	SWITCH, KEYBOARD (TUNER/BAND)	
R733	1-216-841-11	METAL CHIP	47K 5% 1/10W	SW701	1-771-410-21	SWITCH, TACTILE (TUNER/BAND)	(CND, UK, RU)
R734	1-216-821-11	METAL CHIP	1K 5% 1/10W	SW701	1-771-410-21	SWITCH, TACTILE (TUNER/BAND)	(E51, MX, SP, TW, AR, KR, AUS)
R736	1-216-821-11	METAL CHIP	1K 5% 1/10W	SW702	1-762-875-21	SWITCH, KEYBOARD (CD ►►►)	(CND, UK, RU)
R738	1-216-833-11	METAL CHIP	10K 5% 1/10W	SW702	1-771-410-21	SWITCH, TACTILE (CD ►►►)	(E51, MX, SP, TW, AR, KR, AUS)
R739	1-216-833-11	METAL CHIP	10K 5% 1/10W	SW703	1-762-875-21	SWITCH, KEYBOARD (TUNING +, ►►► ►►►)	(CND, UK, RU)
R740	1-216-829-11	METAL CHIP	4.7K 5% 1/10W	SW703	1-771-410-21	SWITCH, TACTILE (TUNING +, ►►► ►►►)	(E51, MX, SP, TW, AR, KR, AUS)
R741	1-216-829-11	METAL CHIP	4.7K 5% 1/10W	SW704	1-762-875-21	SWITCH, KEYBOARD (TUNING -, ►◄◄ ◄◄◄)	(CND, UK, RU)
R742	1-216-821-11	METAL CHIP	1K 5% 1/10W	SW704	1-771-410-21	SWITCH, TACTILE (TUNING -, ►◄◄ ◄◄◄)	(E51, MX, SP, TW, AR, KR, AUS)
R743	1-216-821-11	METAL CHIP	1K 5% 1/10W	SW705	1-762-875-21	SWITCH, KEYBOARD (I/I) (CND, UK, RU)	
R744	1-216-825-11	METAL CHIP	2.2K 5% 1/10W	SW705	1-771-410-21	SWITCH, TACTILE (I/I)	(E51, MX, SP, TW, AR, KR, AUS)
R745	1-216-833-11	METAL CHIP	10K 5% 1/10W	SW706	1-762-875-21	SWITCH, KEYBOARD (SELECT FOLDER -)	(CND, UK, RU)
R746	1-216-825-11	METAL CHIP	2.2K 5% 1/10W	SW706	1-771-410-21	SWITCH, TACTILE (SELECT FOLDER -)	(E51, MX, SP, TW, AR, KR, AUS)
R747	1-216-829-11	METAL CHIP	4.7K 5% 1/10W	SW707	1-762-875-21	SWITCH, KEYBOARD (SELECT FOLDER +)	(CND, UK, RU)
R748	1-216-841-11	METAL CHIP	47K 5% 1/10W	SW707	1-771-410-21	SWITCH, TACTILE (SELECT FOLDER +)	(E51, MX, SP, TW, AR, KR, AUS)
R749	1-216-821-11	METAL CHIP	1K 5% 1/10W	SW708	1-762-875-21	SWITCH, KEYBOARD (FUNCTION)	(CND, UK, RU)
R750	1-216-825-11	METAL CHIP	2.2K 5% 1/10W	SW708	1-771-410-21	SWITCH, TACTILE (FUNCTION)	(E51, MX, SP, TW, AR, KR, AUS)
R751	1-216-821-11	METAL CHIP	1K 5% 1/10W	SW710	1-762-875-21	SWITCH, KEYBOARD (■) (CND, UK, RU)	
R753	1-216-809-11	METAL CHIP	100 5% 1/10W	SW710	1-771-410-21	SWITCH, TACTILE (■)	(E51, MX, SP, TW, AR, KR, AUS)
R754	1-216-833-11	METAL CHIP	10K 5% 1/10W	SW711	1-762-875-21	SWITCH, KEYBOARD (DSGX) (CND, UK, RU)	
R755	1-216-845-11	METAL CHIP	100K 5% 1/10W	SW711	1-771-410-21	SWITCH, TACTILE (DSGX)	(E51, MX, SP, TW, AR, KR, AUS)
R757	1-216-845-11	METAL CHIP	100K 5% 1/10W				
R759	1-216-809-11	METAL CHIP	100 5% 1/10W				
R760	1-216-845-11	METAL CHIP	100K 5% 1/10W				
R761	1-216-841-11	METAL CHIP	47K 5% 1/10W				
R762	1-216-825-11	METAL CHIP	2.2K 5% 1/10W				
R763	1-216-837-11	METAL CHIP	22K 5% 1/10W				
R764	1-216-837-11	METAL CHIP	22K 5% 1/10W				
R765	1-216-829-11	METAL CHIP	4.7K 5% 1/10W				
R766	1-216-797-11	METAL CHIP	10 5% 1/10W				
R767	1-216-849-11	METAL CHIP	220K 5% 1/10W				
R768	1-216-805-11	METAL CHIP	47 5% 1/10W				
R770	1-216-841-11	METAL CHIP	47K 5% 1/10W				
R771	1-216-840-11	METAL CHIP	39K 5% 1/10W				
R772	1-216-837-11	METAL CHIP	22K 5% 1/10W				
R774	1-216-821-11	METAL CHIP	1K 5% 1/10W				
R775	1-216-805-11	METAL CHIP	47 5% 1/10W				
R777	1-216-805-11	METAL CHIP	47 5% 1/10W				
R779	1-216-849-11	METAL CHIP	220K 5% 1/10W				

Ref. No.	Part No.	Description	Remark	Ref. No.	Part No.	Description	Remark
		< VIBRATOR >				ACCESSORIES	
						*****	
X701	1-814-067-11	OSCILLATOR, CRYSTAL (32.768kHz)					
X702	1-813-940-11	PIEZOELECTRIC OSCILLATOR (5.53MHz)		△	1-569-008-22	ADAPTOR, CONVERSION 2P (E51, SP)	
*****				△	1-770-019-61	ADAPTOR, CONVERSION PLUG (UK)	
		PT-AC BOARD					
		*****					
		< CONNECTOR >					
CN002	1-819-131-11	PIN, CONNECTOR 3P					
		< FUSE HOLDER >					
T003	1-533-233-31	FUSE HOLDER					
T004	1-533-233-31	FUSE HOLDER					
*****							
		VOLTAGE-SEL BOARD (E51, SP)					
		*****					
		< SWITCH >					
△ S002	1-786-920-11	SWITCH, VOLTAGE SELECTION (VOTAGE SELECTOR)					
		< FUSE HOLDER >					
T005	1-533-233-31	FUSE HOLDER					
T006	1-533-233-31	FUSE HOLDER					
*****							
		MISCELLANEOUS					
		*****					
△ 4	1-769-079-51	CORD, POWER (KR)					
△ 4	1-775-790-81	CORD, POWER (AUS)					
△ 4	1-790-757-52	CORD, POWER (CND, MX)					
△ 4	1-827-597-81	CORD, POWER (TW)					
△ 4	1-830-891-11	CORD, POWER (UK, E51, SP, RU)					
△ 4	1-832-228-11	CORD, POWER (AR)					
71	A-1313-349-A	MF-EH10 (TAPE MECHANISM DECK)					
102	1-452-899-11	MAGNET					
△ 151	8-820-126-02	OPTICAL PICK-UP BLOCK (KSM-213CDP/C2NP) (Including spindle motor (M401), sled motor (M402))					
152	1-834-268-21	WIRE (FLAT TYPE) (16 CORE)					
△ F001	1-532-275-33	FUSE (T160mAL/250V) (UK, AR, KR, AUS, RU)					
△ F001	1-532-467-33	FUSE (T315mAL/250V) (CND, E51, MX, SP, TW)					
△ F002	1-532-275-33	FUSE (T160mAL/250V) (E51, SP)					
FFC001	1-832-796-21	CABLE, FLEXIBLE FLAT (5 CORE) (RU)					
FFC001	1-832-797-21	CABLE, FLEXIBLE FLAT (5 CORE) (EXCEPT UK, RU)					
FFC001	1-832-807-21	CABLE, FLEXIBLE FLAT (7 CORE) (UK)					
FFC002	1-832-854-21	CABLE, FLEXIBLE FLAT (17 CORE)					
FFC003	1-835-211-21	CABLE, FLEXIBLE FLAT					
△ PT005	1-445-421-11	TRANSFORMER, POWER (AR, KR)					
△ PT005	1-445-422-11	TRANSFORMER, POWER (UK, RU)					
△ PT005	1-445-423-11	TRANSFORMER, POWER (E51, SP, AUS)					
△ PT005	1-445-424-11	TRANSFORMER, POWER (CND, MX, TW)					
S201	1-771-853-11	SWITCH, DETECTION (LIMIT)					
SW750	1-692-960-11	SWITCH, PUSH (1 KEY) (CD LID OPEN/CLOSE DETECT)					
*****							

