

Service
Service
Service



Service Manual



TABLE OF CONTENTS

Handling Chip Components and Safety1 - 1

Technical Specification & Service tools2 - 1

Service Measurement.....2 - 2

Connections and controls3 - 1..3 - 2

Disassembly Diagram.....4 - 1

Block Diagram.....5 - 1

Wiring Diagram.....6 - 1

Circuit diagram

 Main Board

 AF part.....7 - 1

 CD part7 - 2

 Tuner Board.....7 - 3

 MCU Board.....8 - 1

Layout Diagram

 Main Board

 copper side9 - 1

 component side9 - 2

 MCU Board

 copper side10 - 1

 component side10 - 2

Exploded view - cabinet.....11 - 1

Mechanical partslist12 - 1

Electrical partslist12 - 1..12 - 2

© Copyright 2001 Philips Consumer Electronics B.V. Eindhoven, The Netherlands
All rights reserved. No part of this publication may be reproduced, stored in a retrieval system or transmitted, in any form or by any means, electronic, mechanical, photocopying, or otherwise without the prior permission of Philips.

Published by LX 0311 Service Audio Printed in The Netherlands Subject to modification



GB 3140 785 32350



PHILIPS

HANDLING CHIP COMPONENTS

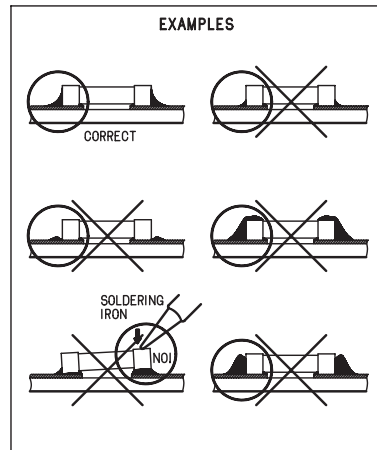
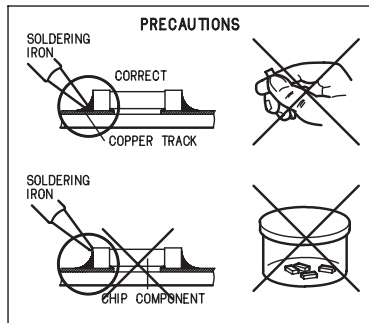
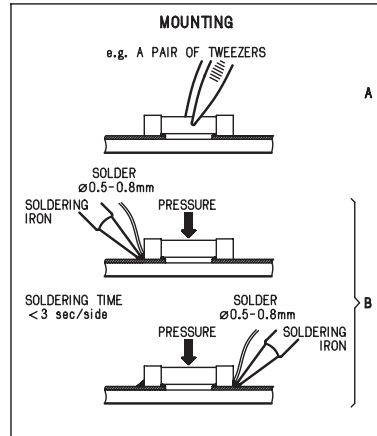
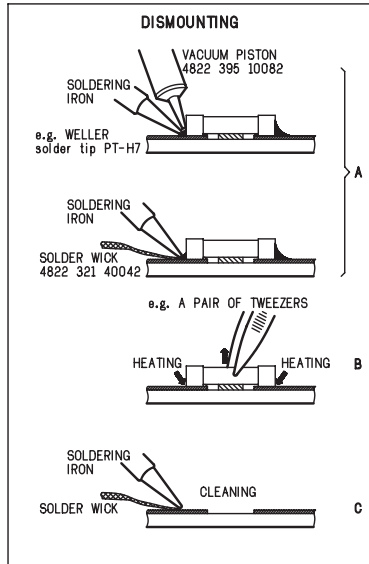
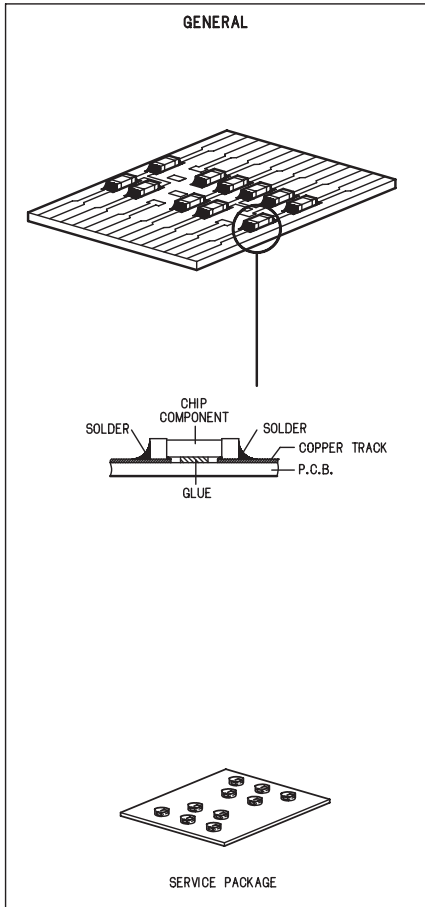

(GB) WARNING

All ICs and many other semiconductors are susceptible to electrostatic discharges (ESD). Careless handling during repair can reduce life drastically. When repairing, make sure that you are connected with the same potential as the mass of the set via a wristband with resistance. Keep components and tools at this potential.

ESD



(NL) WAARSCHUWING

Alle IC's en vele andere halfgeleiders zijn gevoelig voor electrostatische ontladingen (ESD). Onzorgvuldig behandelen tijdens reparatie kan de levensduur drastisch doen verminderen. Zorg ervoor dat u tijdens reparatie via een polsband met weerstand verbonden bent met hetzelfde potentiaal als de massa van het apparaat. Houd componenten en hulpmiddelen ook op ditzelfde potentiaal.

(F) ATTENTION

Tous les IC et beaucoup d'autres semi-conducteurs sont sensibles aux décharges statiques (ESD). Leur longévité pourrait être considérablement écourtée par le fait qu'aucune précaution n'est prise à leur manipulation. Lors de réparations, s'assurer de bien être relié au même potentiel que la masse de l'appareil et enfilez le bracelet sert d'une résistance de sécurité. Veiller à ce que les composants ainsi que les outils que l'on utilise soient également à ce potentiel.

(D) WARNUNG

Alle ICs und viele andere Halbleiter sind empfindlich gegenüber elektrostatischen Entladungen (ESD). Unsorgfältige Behandlung im Reparaturfall kann die Lebensdauer drastisch reduzieren. Sorgen Sie dafür, daß Sie im Reparaturfall über ein Pulsarmband mit Widerstand mit dem Massepotential des Gerätes verbunden sind. Halten Sie Bauteile und Hilfsmittel ebenfalls auf diesem Potential.

(I) AVVERTIMENTO

Tutti IC e parecchi semi-conduttori sono sensibili alle scariche statiche (ESD). La loro longevità potrebbe essere fortemente ridatta in caso di non osservazione della più grande cauzione alla loro manipolazione. Durante le riparazioni occorre quindi essere collegato allo stesso potenziale che quello della massa dell'apparecchio tramite un bracciale a resistenza. Assicurarsi che i componenti e anche gli utensili con quali si lavora siano anche a questo potenziale.

(GB)

Safety regulations require that the set be restored to its original condition and that parts which are identical with those specified be used. Safety components are marked by the symbol

(F)

Les normes de sécurité exigent que l'appareil soit remis à l'état d'origine et que soient utilisées les pièces de rechange identiques à celles spécifiées. Les composants de sécurité sont marqués

SAFETY



(D)

Bei jeder Reparatur sind die geltenden Sicherheitsvorschriften zu beachten. Der Originalzustand des Gerätes darf nicht verändert werden. Für Reparaturen sind Originalersatzteile zu verwenden. Sicherheitsbauteile sind durch das Symbol markiert.

(NL)

Veiligheidsbepalingen vereisen, dat het apparaat in zijn oorspronkelijke toestand wordt teruggebracht en dat onderdelen, identiek aan de gespecificeerde, worden toegepast. De Veiligheidsonderdelen zijn aangeduid met het symbool

(I)

Le norme di sicurezza estigono che l'apparecchio venga rimesso nelle condizioni originali e che siano utilizzati i pezzi di ricambio identici a quelli specificati. Componenti di sicurezza sono marcati con

(GB)

DANGER: Invisible laser radiation when open. AVOID DIRECT EXPOSURE TO BEAM.

(S) Varning !

Osynlig laserstrålning när apparaten är öppnad och spärren är urkopplad. Betrakta ej strålen.

(DK) Advarsel !

Usynlig laserstrålning ved åbning når sikkerhedsafbrydere er ude af funktion. Undgå udsættelse for stråling.



(FIN) Varoitus !

Avatussa laitteessa ja suojalukituksen ohitettaessa olet alttiina näkymättömälle laserisäteilylle. Älä katso säteeseen !

(GB)

After servicing and before returning the set to customer perform a leakage current measurement test from all exposed metal parts to earth ground, to assure no shock hazard exists. The leakage current must not exceed 0.5mA.

(F)

"Pour votre sécurité, ces documents doivent être utilisés par des spécialistes agréés, seuls habilités à réparer votre appareil en panne".

TECHNICAL SPECIFICATIONS

GENERAL

Mains voltage	-/00/05 : 230 V
	-/17 : 120 V
Mains frequency	-/00/05 : 50 Hz
	-/17 : 60 Hz
Battery	mains : 9 V (R14 x 6)
Power consumption	: < 5 W typ.
Dimension (L x D x H)	: 360 x 225 x 152 mm
Weight	: 2.3 Kg

AMPLIFIER

Output power	mains : 2 x 1 W
	battery : 2 x 1 W
Speaker impedance	: 2 x 8 ohm
Frequency response	: 100 Hz -10 kHz (± 2 dB)

TUNER - FM SECTION

Tuning range	: 87.5 - 108 MHz
IF frequency	: 10.7 MHz ± 0.2 MHz
Sensitivity	: < 22 dBf at 26dB S/N
Selectivity	: > 20 dB at ± 300 kHz
IF rejection	: > 50 dB
Image rejection	: > 20 dB

TUNER - MW SECTION

Tuning range	: 520 - 1602 kHz
	-/17 : 530 - 1700 kHz
IF frequency	: 450 kHz ± 1 kHz
Sensitivity	: < 5000 μ V/m at 26dB S/N
Selectivity	: > 16 dB
IF rejection ratio	: > 24 dB
Image rejection ratio	: > 28 dB

AUDIO CASSETTE RECORDER

Number of tracks	: 1 stereo
Tape speed	: 4.76 cm/sec $\pm 3\%$
Wow & flutter	: < 0.35 % JIS UWTD
Fast wind/rewind C60	: < 130 sec.
Frequency response	P/B : 125 - 8000 Hz
S/N ratio	: > 36 dB

COMPACT DISC

S/N ratio	: > 50 dB
Channel difference	1 kHz : < 3 dB
Channel crosstalk	1 kHz : > 26 dB
Laser wavelength	: 780 ± 20 nm
Laser light power	: < 0.3 mW

SERVICE TOOLS

Audio signal disc SBC 429.....	4822 397 30184
Playability test disc SBC 444.....	4822 397 30245
Test disc 5 (disc without errors) +	
Test disc 5A (disc with dropout errors, black spots and fingerprints)	
SBC 426/426A.....	4822 397 30096
Burn in test disc (65 min. 1kHz signal at -30 dB level without "pause").....	4822 397 30155

AVAILABLE ESD PROTECTION EQUIPMENT

anti-static table mat large 1200x650x1.25mm	4822 466 10953
small 600x650x1.25m	4822 466 10958
anti-static wristband	4822 395 10223
connection box (3 press stud connections, 1M Ω)	4822 320 11307
extendible cable (2m, 2M Ω , to connect wristband to connection box)	4822 320 11305
connecting cable (3m, 2M Ω , to connect table mat to connection box)	4822 320 11306
earth cable (1M Ω , to connect any product to mat or to connection box)	4822 320 11308
KIT ESD3 (combining all 6 prior products - small table mat)	4822 310 10671
wristband tester	4822 344 13999

SERVICE MEASUREMENT

Tuner SW

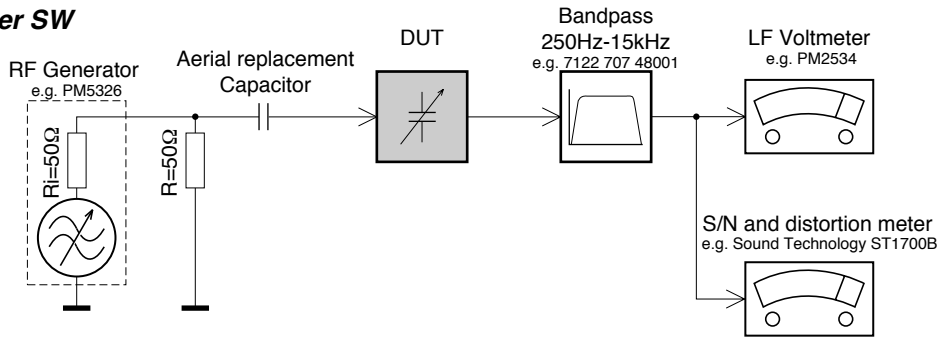

To avoid atmospheric interference all AM-measurements have to be carried out in a Faraday«s cage. Use a bandpass filter (or at least a high pass filter with 250Hz) to eliminate hum (50Hz, 100Hz).

Tuner AM (MW,LW)

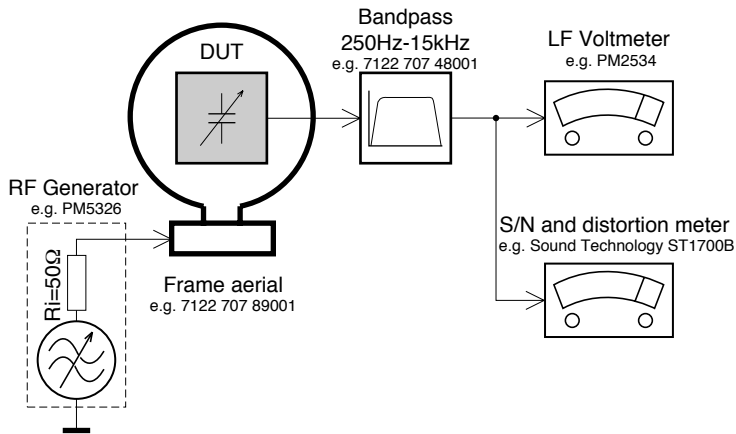

To avoid atmospheric interference all AM-measurements have to be carried out in a Faraday«s cage.

CD

Use Audio Signal Disc SBC429 4822 397 30184 (replaces test disc 3)
L.P.F. = 13th order filter 4822 395 30204

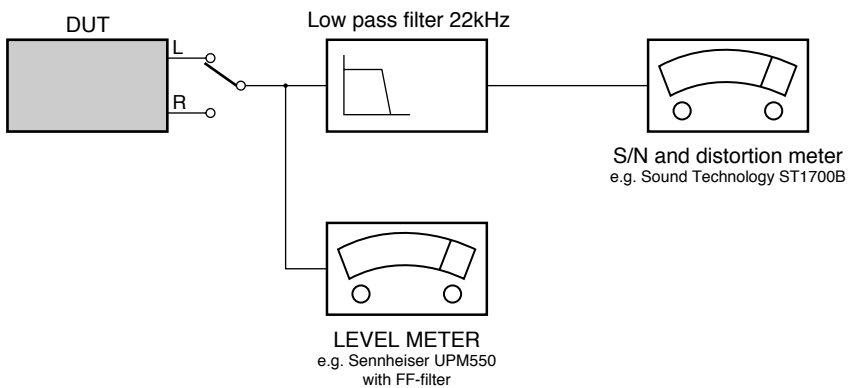

CONNECTIONS AND CONTROLS

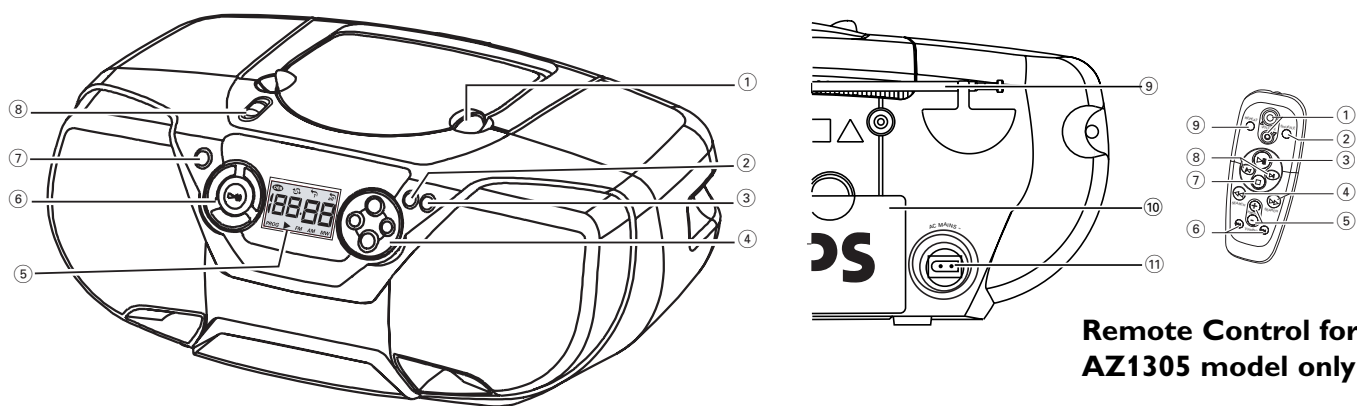

Remote Control for AZ1305 model only

English

CONTROL

POWER SUPPLY

ACCESSORIES

- 1 x AC mains lead
- 1 x Remote Control (for **AZ1305** model only)

TOP AND FRONT PANEL (See [1])

- ① **LIFT TO OPEN** - lift here to open CD door.
- ② **PROG**
CD: - programs tracks and reviews the program;
Tuner: - programs preset radio stations.
- ③ **MODE** - selects different play modes: e.g. **REPEAT** or **SHUFFLE** (random) order.
- ④ **VOLUME ▲, ▼** - to adjust volume level.
PRESET +, - (up, down) - selects a preset radio station.
- ⑤ **Display** - shows the status of the set.
- ⑥ **▶||** - starts or pauses CD playback.
■ - to stop playback or erase a CD program.
SEARCH ◀◀, ▶▶
CD: - searches backward and forward within a track;
- skips to the beginning of a current track/
previous/ later track.
RADIO: - (down, up) tunes to radio stations.
- ⑦ **DBB (Dynamic Bass Boost)** - activates a more vivid bass response.
- ⑧ **POWER slider** - selects **CD/ MW / FM / OFF** function and also the power off switch (**OFF**).

BACK PANEL (See [1])

- ⑨ **Telescopic aerial** - improves FM reception.
- ⑩ **Battery compartment** - for 6 batteries, type **R-14, UM2** or **C-cells**.
- ⑪ **AC MAINS** - inlet for mains lead.

REMOTE CONTROL (for AZ1305 model only)

- ① **VOLUME ▲, ▼** - adjusts volume level.
- ② **SHUFFLE** - plays all CD tracks in random order.
- ③ **▶||** - starts or pauses CD playback.
- ④ **SEARCH ◀◀, ▶▶** - searches backwards/ forwards within a track.
- ⑤ **PRESET +, -** (up, down) - selects a preset radio station.
- ⑥ **TUNING ◀◀, ▶▶** (down, up) - tunes to tuner stations.
- ⑦ **■** - to stop playback;
- erases a CD program.
- ⑧ **◀, ▶** - skips to the beginning of a current track previous/ subsequent track.
- ⑨ **REPEAT** - repeats a track /program/ entire CD.

CAUTION

Use of controls or adjustments or performance of procedures other than herein may result in hazardous radiation exposure or other unsafe operation.

POWER SUPPLY

Whenever convenient, use the AC power supply to conserve battery life. Make sure you remove the power plug from the set and wall outlet before inserting batteries.

Batteries (not included)

- Insert 6 batteries, type **R-14, UM-2** or **C-cells**, (preferably alkaline) with the correct polarity. (See [6])
- **Remote control (AZ1305 model only)**
Insert 2 batteries, type **AAA, R03** or **UM4** (preferably alkaline). (See [8])

IMPORTANT!

- Incorrect use of batteries can cause electrolyte leakage and will corrode the compartment or cause the batteries to burst.
- Do not mix battery types: e.g. alkaline with carbon zinc. Only use batteries of the same type for the set.
- When inserting new batteries, do not try to mix old batteries with the new ones.
- **Batteries contain chemical substances, so they should be disposed of properly.**

Using AC Power

1. Check if the AC power supply, as shown on the **type plate located on the bottom of the set**, corresponds to your local power supply. If it does not, consult your dealer or service centre.
2. Connect the mains lead to the wall socket.
3. To disconnect the mains supply, unplug the set from the wall socket.

This set complies with the radio interference requirements of the European Community.

For users in the U.K., please follow the boxed instructions 'Important notes...' on this sheet.

BASIC FUNCTIONS

Switching on and off and selecting function

1. To switch on, adjust the **POWER slider** to select: **CD, MW (AM), FM** function, and operate the respective function controls.
2. To switch off, adjust the **POWER slider** to select **OFF**.

Note : The **DBB** setting, tuner presets and the volume level (maximum to 20) will be retained in the set's memory.

Adjusting volume and sound (See [2])

1. Adjust the volume with the **VOLUME** controls.
→ Display shows the volume level in number from 0-32.
2. Press **DBB** once or more to select dynamic bass boost on or off.
→ Display: shows **DBB** when activated.

CONNECTIONS AND CONTROLS

DIGITAL TUNER

DIGITAL TUNER

Tuning to radio stations

- Adjust the **POWER slider** to **MW** or **FM**.
 - The radio, station frequency, waveband are shown (See [3]).
- Press and hold **SEARCH** ◀◀ or ▶▶ until the frequency in the display starts running.
 - The radio automatically tunes to a station of sufficient reception. Display shows *S r c h* during automatic tuning.
- Repeat step 2 if necessary until you find the desired station.
 - To tune to a weak station, press ◀◀ or ▶▶ briefly and repeatedly until you have found optimal reception.

To improve radio reception:

- For **FM**, extend, incline and turn the telescopic aerial. Reduce its length if the signal is too strong.
- For **MW**, the set uses a built-in aerial. Direct this aerial by turning the whole set.

Programming radio stations

You can store up to a total of 30 radio stations (20 FM and 10 MW) in the memory, manually or automatically (Autostore).

CD PLAYER

Programming track numbers

In the stop position, select and store your CD tracks in the desired sequence. Up to 20 tracks can be stored in the memory.

- Press **SEARCH** ◀◀ or ▶▶ on the set to select your desired track number.
- Press **PROG**.
 - Display: *PROG, P r o g* briefly and your selected track number. (See [5])
 - If you attempt to program without first selecting a track number, *n o S E* is shown.
- Repeat steps 1-2 to select and store all desired tracks.
 - Display: *F u l l* if you try to program more than 20 tracks.

Reviewing the program

In the stop position, press and hold **PROG** until the display shows all your stored track numbers in sequence.

Erasing a program

You can erase the program by either:

- pressing ■ twice
 - *E r a s e* is displayed briefly and **PROG** disappears.
- You select **MW / FM** function.
- Open the CD door.

DIGITAL TUNER

Manual programming

- Tune to your desired station (see **Tuning to radio stations**).
- Press **PROG** to activate programming.
 - **PROG** flashes.
- Press **PRESET + / -** once or more to select a preset number.
 - **Remote control (AZ1305 models only):** Press **PRESET + / -** once or more to select a preset station.
- Press **PROG** to confirm.
- Repeat steps 1-4 to store other stations.

Note : You can erase a preset station by storing another frequency in its place.

Autostore

Autostore automatically starts programming radio stations from preset 1. Available stations are programmed in order if the station with sufficient reception strength. Any previous presets e.g. manually programmed will be erased.

- Press **PROG** for 2 seconds or more to activate autostore programming.
 - The display shows *R U L D*, **PROG** blinks, followed by the radio station details when stored.

After all stations are stored, the first preset station will then automatically play.

To listen to a preset station

- Press the **PRESET + , -** buttons once or more until the desired preset station is displayed.
- Remote control (**AZ1305** models only): optionally, press **PRESET + , -** to select your preset station.

SAFETY & MAINTENANCE

SAFETY & MAINTENANCE INFORMATION

(See [7])

- Don't expose the set, batteries, CDs to humidity, rain, sand or excessive heat.
- Clean the set with a dry cloth. Don't use any cleaning agents containing alcohol, ammonia, benzene or abrasives as these may harm the set.
- Place the set on a hard and flat surface so that the system does not tilt. Make sure there is good ventilation to prevent the set overheating.
- The mechanical parts of the set contain self-lubricating bearings and must not be oiled or lubricated.

CD player and CD handling

- If the CD player cannot read CDs correctly, use a cleaning CD to clean the lens before taking the set to repair.
- The lens of the CD player should never be touched!
- Sudden changes in the surrounding temperature can cause condensation on the lens of your CD player. Playing a CD is then not possible. Do not attempt to clean the lens but leave the set in a warm environment until the moisture evaporates.
- Always close the CD door to avoid dust on the lens.
- To clean the CD, wipe in a straight line from the centre towards the edge using a soft, lint-free cloth. Do not use cleaning agents as they may damage the disc.
- Never write on a CD or attach any stickers to it.

CD PLAYER

Playing a CD

This CD player plays Audio Discs including CD-Recordables and CD-Rewritables.

- Adjust the **POWER slider** to **CD**.
- Open the CD Door.
 - *D P E R* is displayed.
- Insert a CD with the printed side facing up and close the door.
 - *n o c d* if no CD inserted/ CD dirty, incorrectly inserted or damaged.
 - *n F c d* if you have inserted a non-finalized CD-R(W).
- Press **▶II** to start playback.
 - *d R L R* if your CD contains non-audio i.e. data files.
- To pause playback press **▶II**. Press **▶II** again to resume play.
 - Display: ◀ flashes during pause.
- To stop CD playback, press the ■ button.

Note : CD play will also stop when:

- the CD door is opened
- the CD has reached the end
- you select **MW / FM** function.

Selecting a different track

- Press **SEARCH** ◀◀ or ▶▶ once or repeatedly to select your track.
- In the pause / stop position, press **▶II** to start playback.

TROUBLESHOOTING

If a fault occurs, first check the points listed below before taking the set for repair. If you are unable to remedy a problem by following these hints, consult your dealer or service centre.

WARNING: Do not open the set as there is a risk of electric shock! Under no circumstances should you try to repair the set yourself, as this will invalidate the guarantee.

No sound /power

- Volume not adjusted
- Adjust the VOLUME
- Mains lead not securely connected
- Connect the AC mains lead properly
- Batteries exhausted/ incorrectly inserted
- Insert (fresh) batteries correctly

Severe radio hum or noise

- Electrical interference: set too close to TV, VCR or computer
- Move the set to increase the distance

Poor radio reception

- Weak radio signal
- FM: Adjust the FM telescopic aerial

n o c d indication

- CD badly scratched or dirty
- Replace/ clean CD, see Maintenance
- Laser lens steamed up
- Wait until lens has cleared

n F c d indication

- CD-R(W) is blank/ not finalized
- Use a finalized CD-R(W)

CD PLAYER

Finding a passage within a track

- Press and hold **SEARCH** ◀◀ or ▶▶.
 - The CD is played at high speed and low volume.
- When you recognize the passage you want, release ◀◀ or ▶▶ to resume normal playback.
 - Note :** During a CD program or if **SHUFFLE/ REPEAT** active, searching is only possible within a track.

Different play modes: SHUFFLE and REPEAT

You can select and change the various play modes before or during playback, and combine the modes with **PROG**. (See [4])

- SHUFFLE** - tracks of the entire CD/ program are played in random order
- SHUFFLE REPEAT ALL** - to repeat the entire CD/ program continuously in random order
- REPEAT ALL** - repeats the entire CD/ program
- REPEAT** - plays the current track continuously

- To select play mode, press **MODE** once or more.
- Press **▶II** to start playback if in the stop position.
- To select normal playback, press **MODE** repeatedly until the various modes are no longer displayed.
 - You can also press the ■ button to cancel your play mode.

Environmental information

We have done our best to reduce the packaging and make it easy to separate into 3 materials: cardboard, expandable polystyrene, polyethylene.

Your set consists of materials which can be recycled if disassembled by a specialized company. Please observe the local regulations regarding the disposal of packaging, exhausted batteries and old equipment.

For more information on operation instruction please visit Philips Audio internet site :

<http://www.audio.philips.com>

DISASSEMBLY DIAGRAM

A. REMOVE FRONT CABINET ASSEMBLY

- REMOVE SCREWS A1 (3X20) 6 PCS.
- REMOVE SCREW A2 (3X55) 1 PC
(INSIDE BATTERY COMPARTMENT)

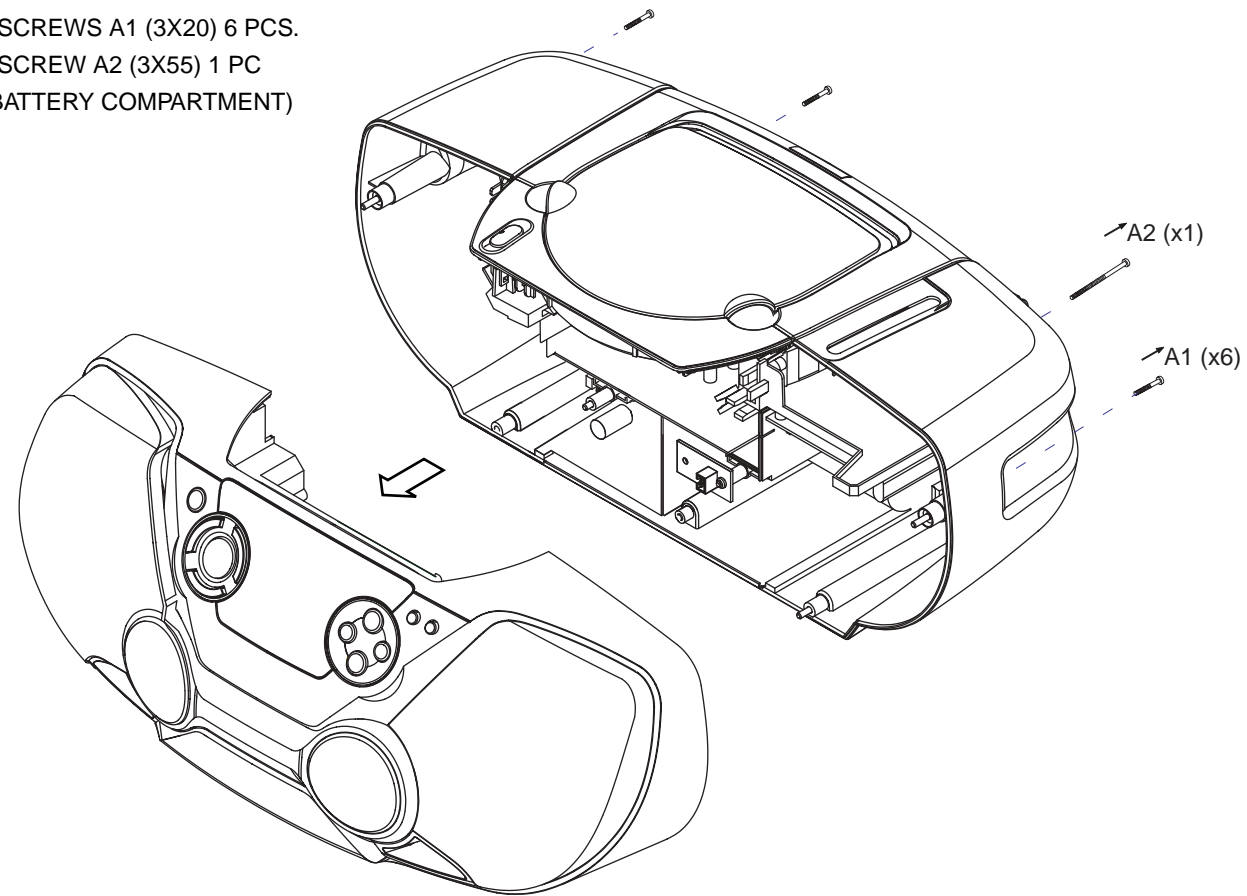

B. REMOVE BOTTOM CABINET ASSEMBLY

- REMOVE SCREWS B3 (3X8) 2 PCS.

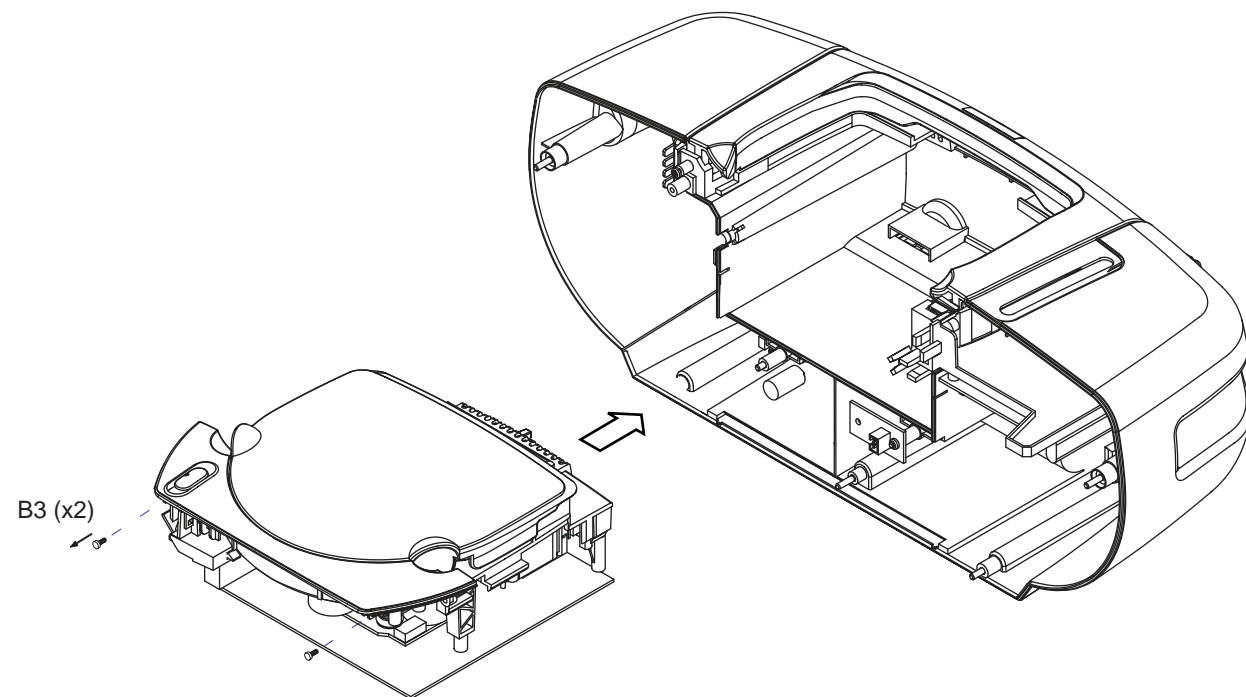

C. REMOVE DECK MECHANISM

- REMOVE SCREWS C4 (2.5X8) 6 PCS.
- REMOVE MAIN BOARD
- REMOVE SCREWS C5 (2.5X10) 4 PCS.
- REMOVE CD DECK

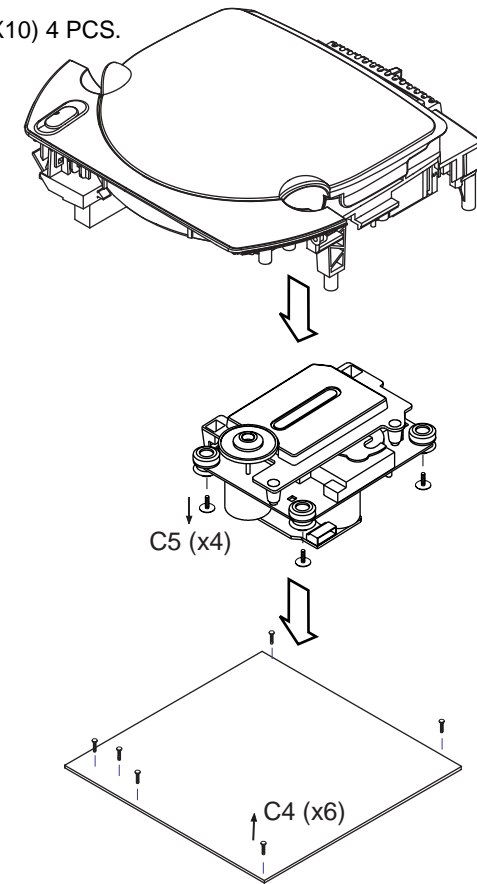

D. REMOVE FRONT PANEL

- REMOVE SCREWS D6 (2.5X10) 8 PCS.
- REMOVE SCREWS D7 (2.5X8) 6 PCS.

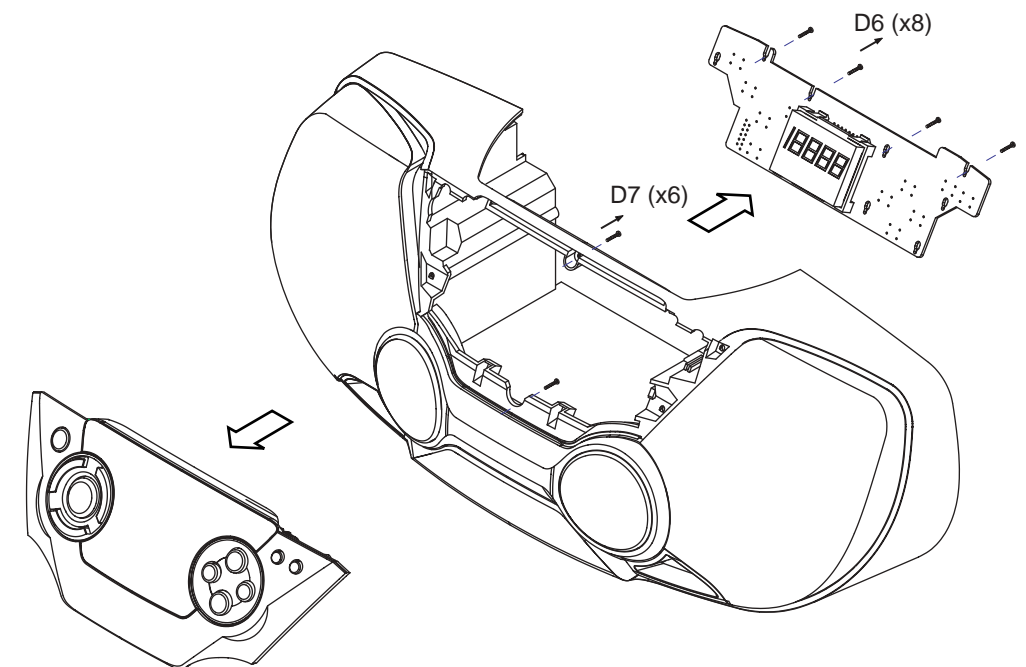

BLOCK DIAGRAM

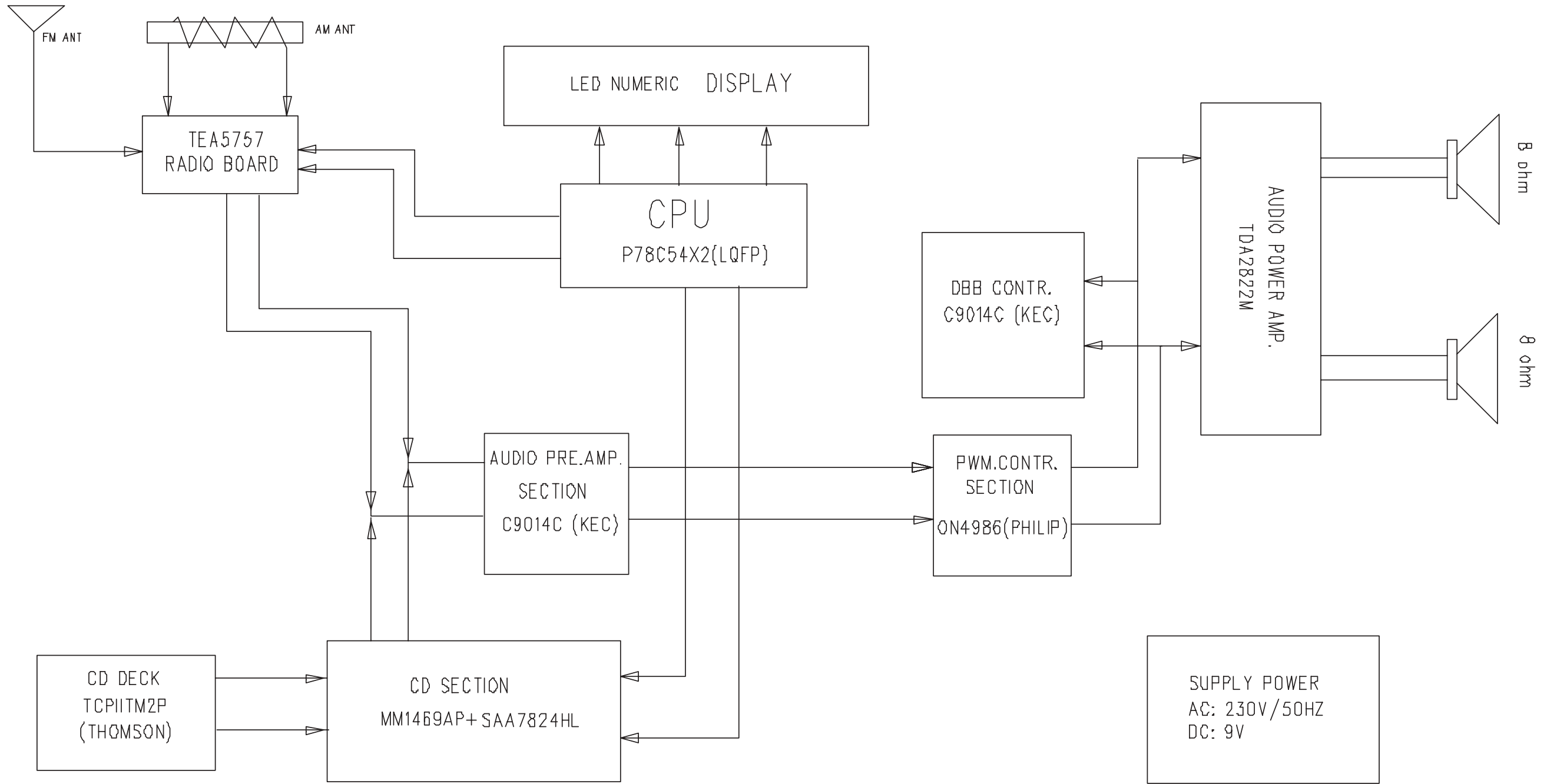

WIRING DIAGRAM

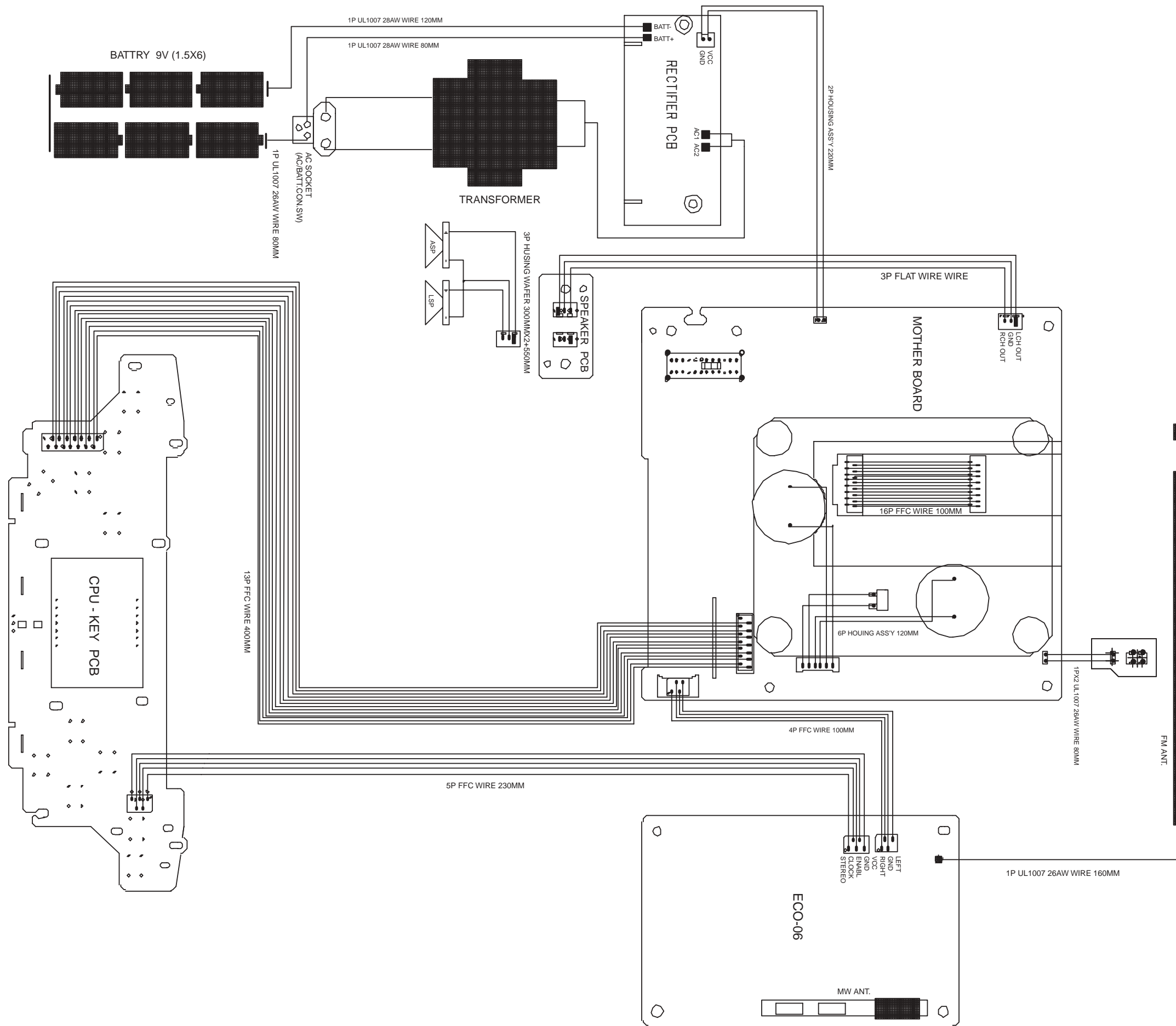

CIRCUIT DIAGRAM - MAIN BOARD (AF PART)

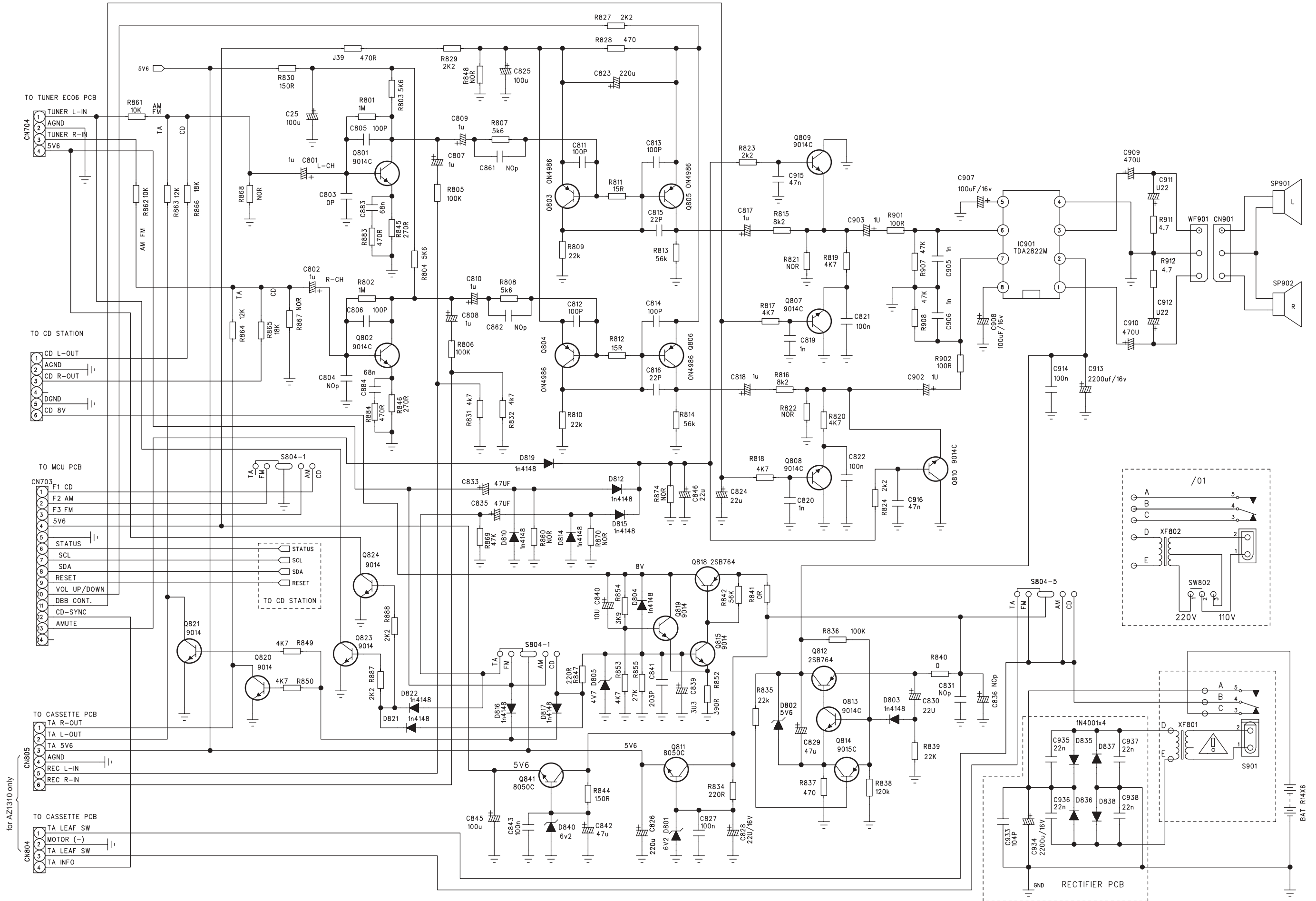

CIRCUIT DIAGRAM - MAIN BOARD (CD PART)

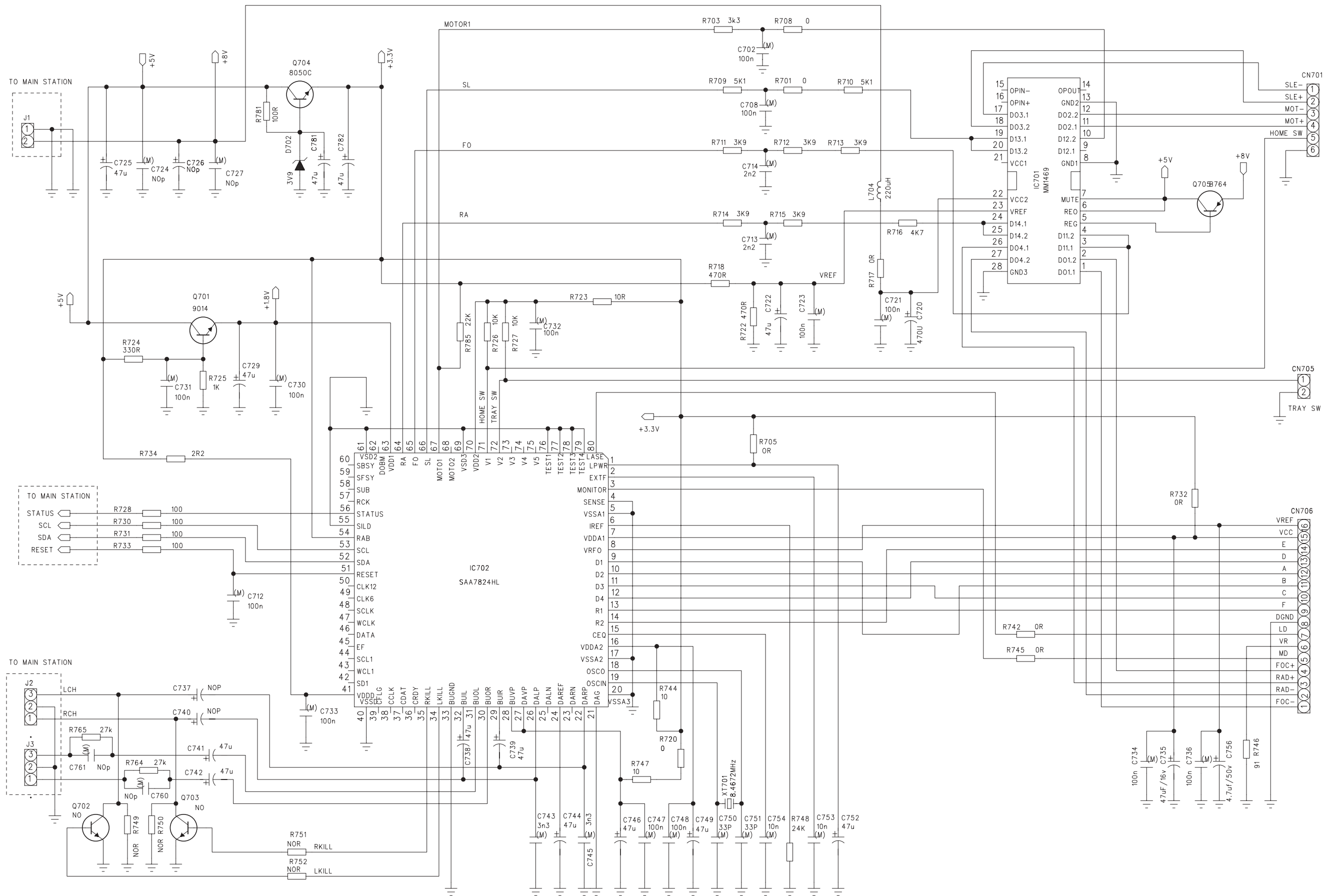

CIRCUIT DIAGRAM - TUNER BOARD

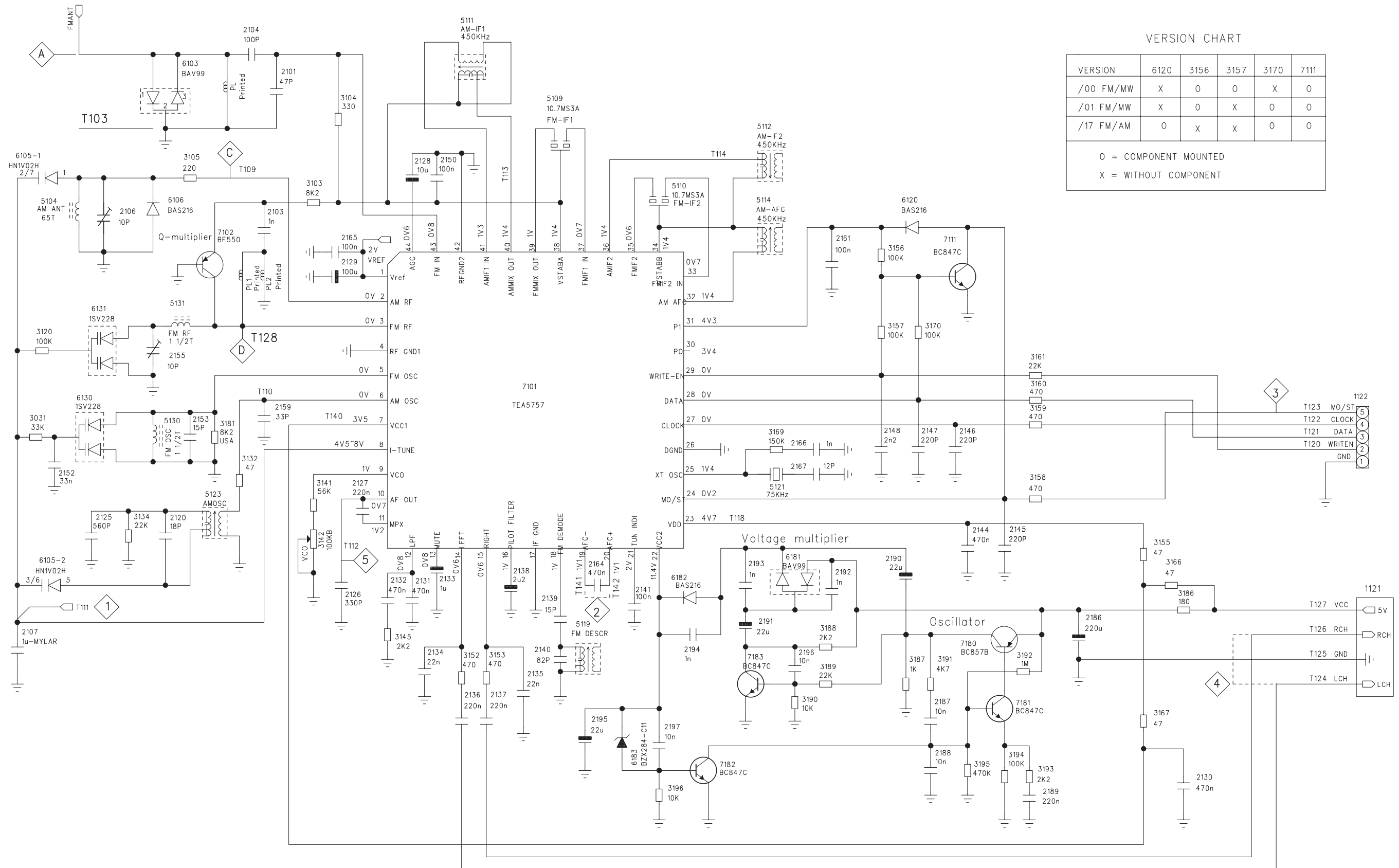

VERSION CHART

VERSION	6120	3156	3157	3170	7111
/00 FM/MW	X	0	0	X	0
/01 FM/MW	X	0	X	0	0
/17 FM/AM	0	X	X	0	0

O = COMPONENT MOUNTED
X = WITHOUT COMPONENT

CIRCUIT DIAGRAM - MCU BOARD

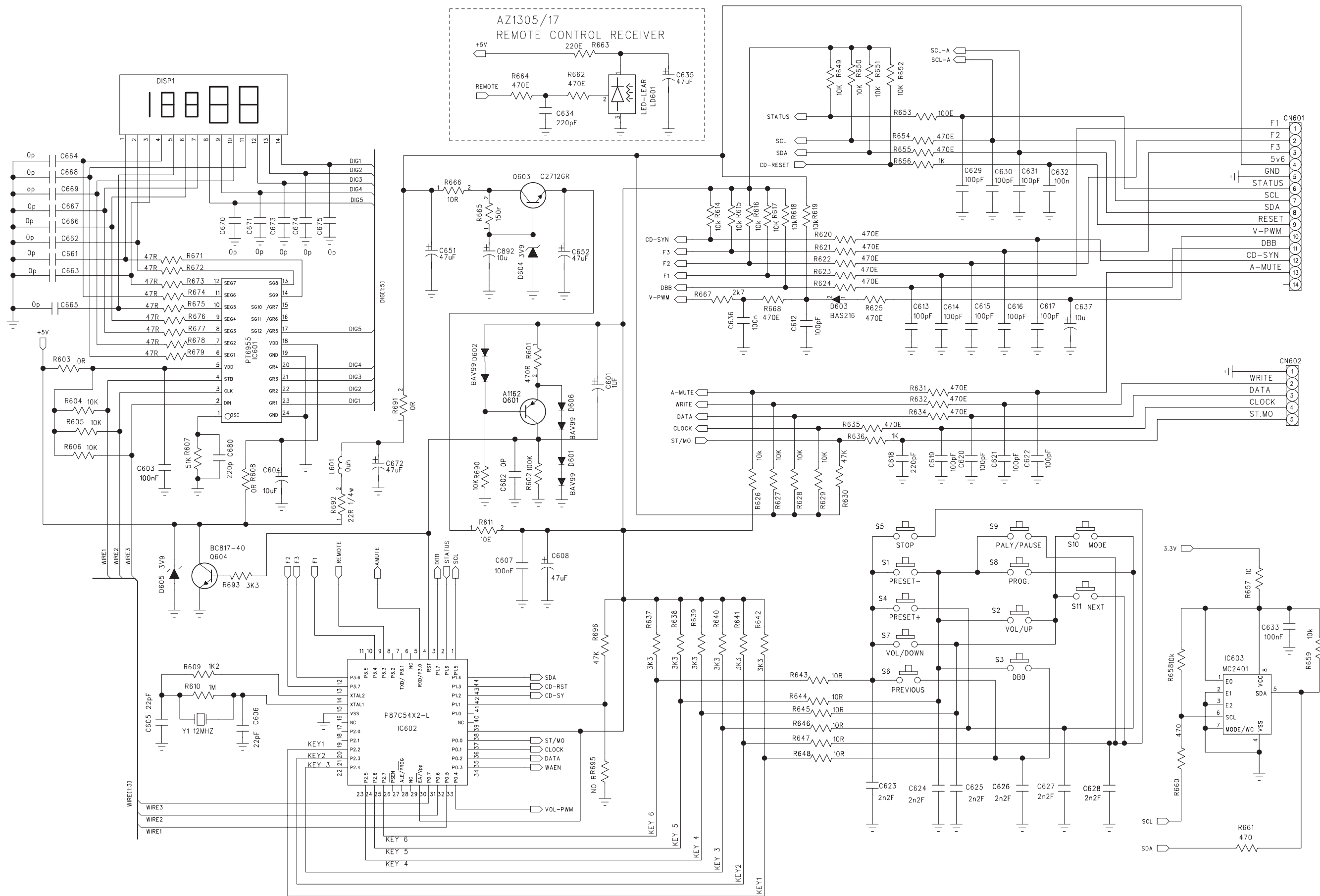

LAYOUT DIAGRAM - MAIN BOARD
(COPPER SIDE VIEW)

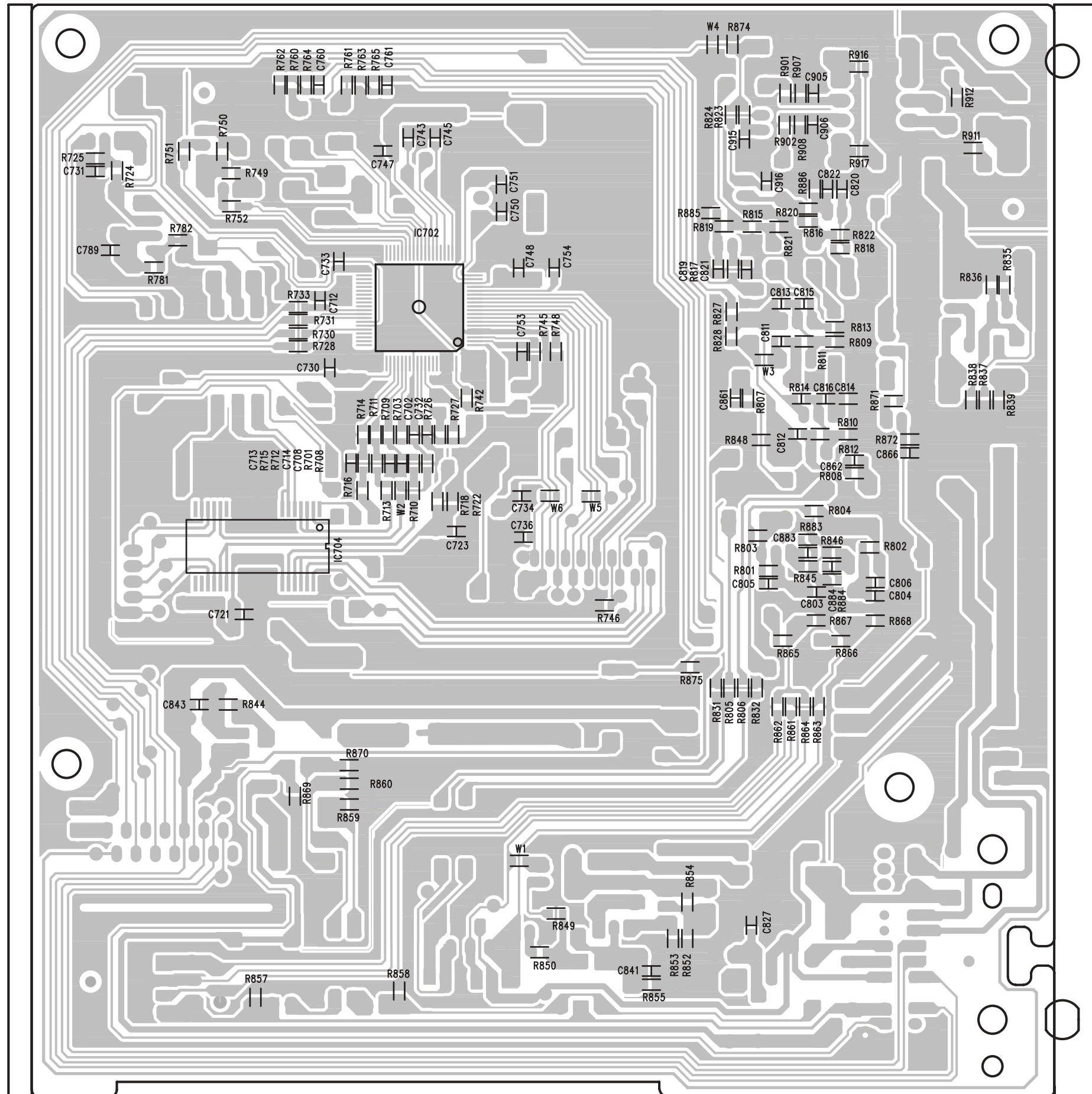

LAYOUT DIAGRAM - MAIN BOARD
(COMPONENT SIDE VIEW)

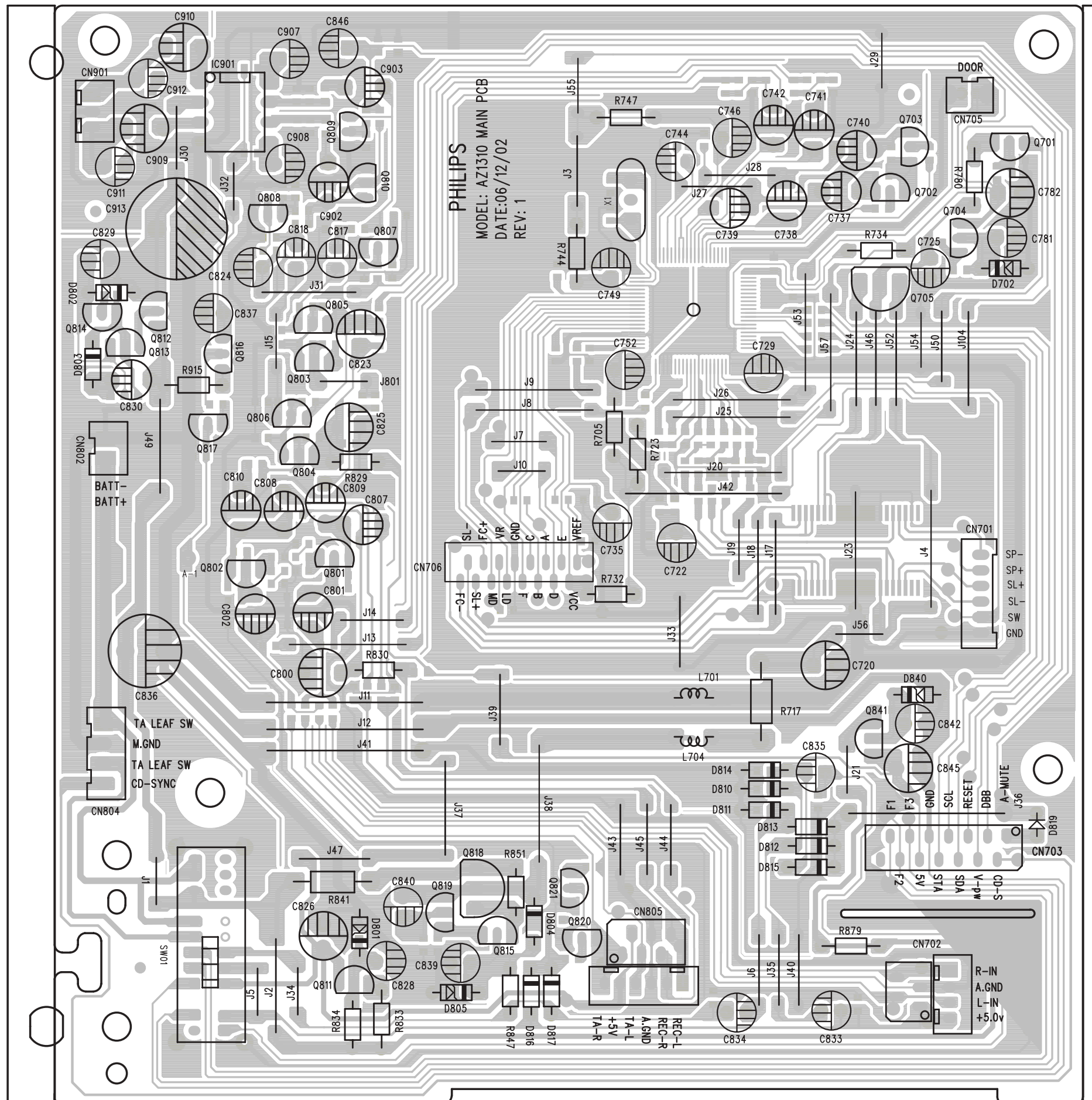

LAYOUT DIAGRAM- MCU BOARD
(COPPER SIDE VIEW)

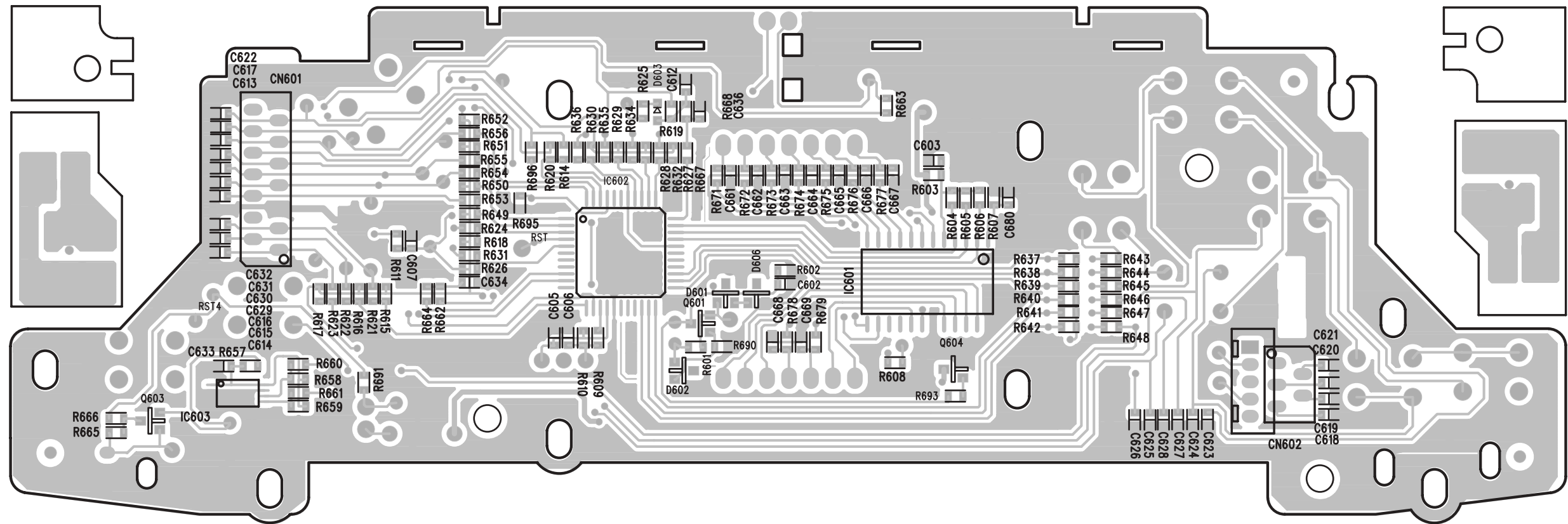

LAYOUT DIAGRAM - MCU BOARD (COMPONENT SIDE VIEW)

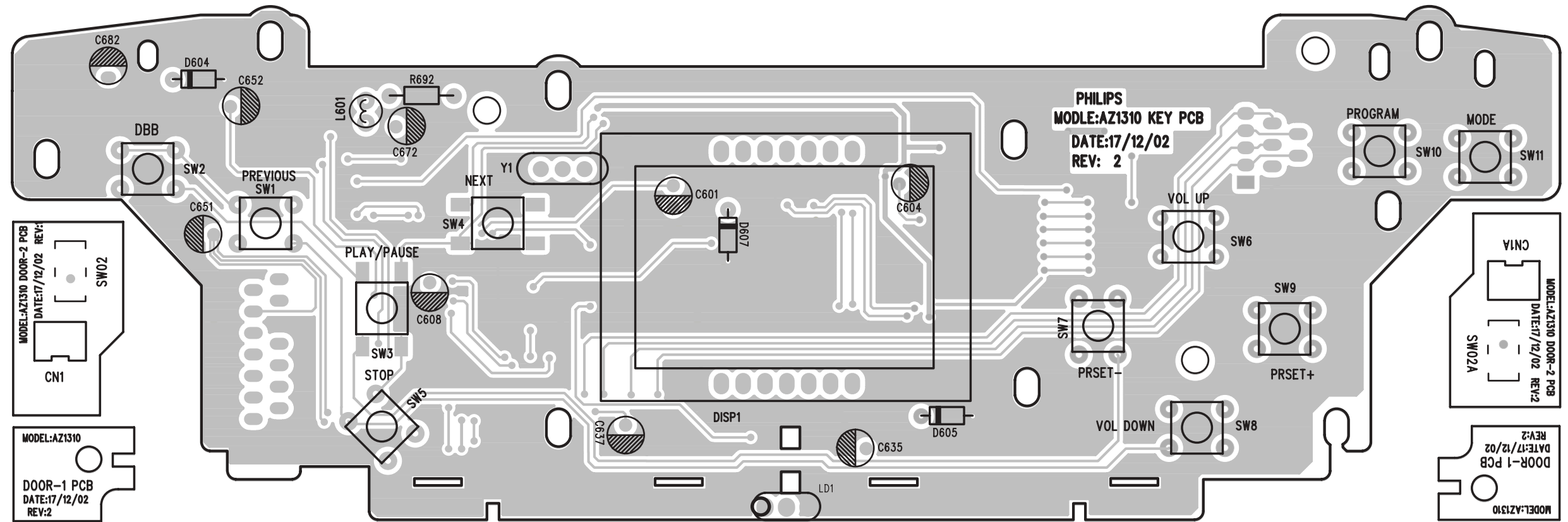

EXPLODED VIEW DIAGRAM - CABINET

SCREW LIST :

①	M3x6
②	T2 x 8
③	T2.5 x 8
④	T2.5 x 10
⑤	T3 x 8
⑥	T3 x 10
⑦	T3 x 12
⑧	T3 x 16
⑨	T3 x 20
⑩	T3 x 32
⑪	C P/W 2.5 x 10
⑫	T P/W 3 x 10
⑬	T P/W 3 x 16

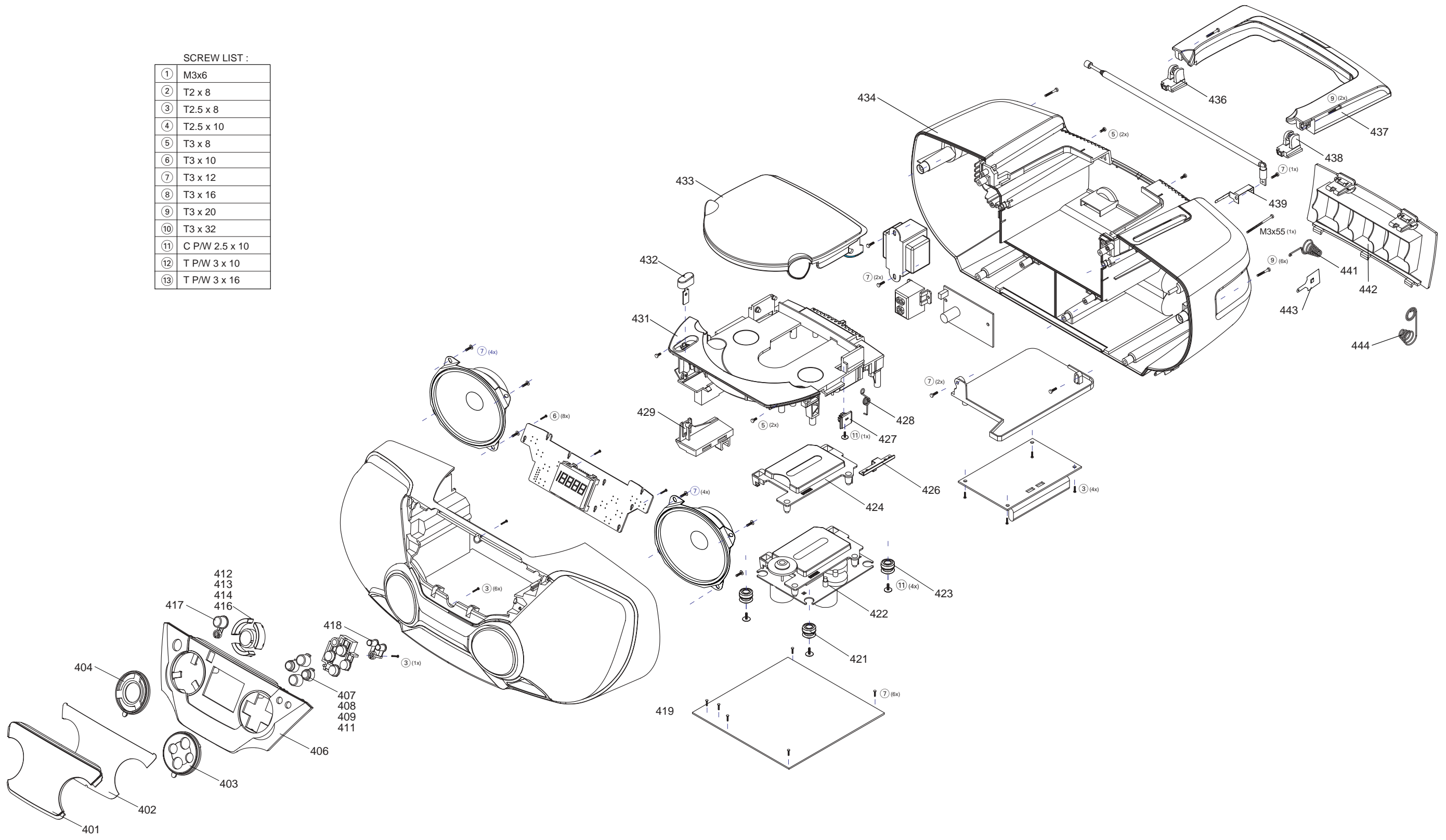

MECHANICAL PARTSLIST

401	9965 000 16941	DISPLAY LENS
402	9965 000 16947	PC MAGIC MIRROR
403	9965 000 16946	COSMETIC DISC (R)
404	9965 000 16945	COSMETIC DISC (L)
406	9965 000 16940	FRONT PANEL
407	9965 000 16855	VOLUME KNOB - (UP)
408	9965 000 16856	VOLUME KNOB - (DOWN)
409	9965 000 16857	PRESET KNOB - (UP)
411	9965 000 16858	PRESET KNOB - (DOWN)
412	9965 000 16860	PREVIOUS KNOB
413	9965 000 16861	STOP KNOB
414	9965 000 16862	NEXT KNOB
416	9965 000 16948	PLAY KNOB
417	9965 000 16950	DBB KNOB
418	9965 000 16949	MODE/PROGRAM KNOB
419	9965 000 16938	FRONT CABINET
421	9965 000 16883	CUSHION 658PH (GREY)
422	9965 000 16884	CD DECK TCP11TM2P
423	9965 000 16882	CUSHION 658PG (BLACK)
424	9965 000 16881	DUST COVER SK-02
426	9965 000 16870	DAMPER HOLDER BRACKET
427	9965 000 16850	CD DOOR GEAR
428	9965 000 16875	CD DOOR SPRING
429	9965 000 16849	FUNCTION KNOB ADAPTOR
431	9965 000 16955	CD TRAY (-/17)
431	9965 000 16944	CD TRAY
432	9965 000 16859	FUNCTION KNOB
433	9965 000 16943	CD DOOR
434	9965 000 16939	BOTTOM CABINET
436	9965 000 16854	HANDLE HINGE - (R)
437	9965 000 16841	HANDLE
438	9965 000 16853	HANDLE HINGE - (L)
439	9965 000 16871	ANTENNA CONTACT PLATE
441	9965 000 16873	BATTERY SPRING - (-)
442	9965 000 16942	BATTERY DOOR
443	9965 000 16872	BATTERY CONTACT PLATE - (+)
444	9965 000 16874	BATTERY SPRING - (+-)
	9965 000 17018	REMOTE CONTROL RC19414002
	9965 000 16956	LEAFLET (-/17)

Note: Only these parts mentioned in the list are normal service parts.

ELECTRICAL PARTSLIST**- MISCELLANEOUS -**

1106	9965 000 16396	ROD ANTENNA
SW01	9965 000 16886	FERRITE BAR
SW02	9965 000 16887	BAND SWITCH
SW1	9965 000 16888	DETECTOR SWITCH
	9965 000 13705	TACT-SWITCH
SW2	9965 000 13705	TACT-SWITCH
SW3	9965 000 16889	TACT-SWITCH
SW4	9965 000 16889	TACT-SWITCH
SW5	9965 000 13705	TACT-SWITCH
SW6	9965 000 13705	TACT-SWITCH
SW7	9965 000 13705	TACT-SWITCH
SW8	9965 000 13705	TACT-SWITCH
SW9	9965 000 13705	TACT-SWITCH
SW10	9965 000 13705	TACT-SWITCH
SW11	9965 000 13705	TACT-SWITCH
	9322 155 82667	IR RECEIVER
	9965 000 16891	FERRITE BEAD
	9965 000 16892	FFC CABLE WIRE 13P
	9965 000 16894	FFC CABLE WIRE 4P
	9965 000 16895	FFC CABLE WIRE 5P
	9965 000 16954	SPEAKER 4" 8 OHM 3W
	9965 000 16957	TRANSFORMER
	9965 000 16958	AC SOCKET
	2422 070 98152	MAINSCORD 1,79MHz

- CAPACITORS AND RESISTERS-

3142	9965 000 16900	SEMI-FIXED 100KB
2155	4822 125 11113	TRIM CAPACITOR
2106	9965 000 16901	TRIMMER CVN620

- COILS & FILTERS -

5104	9965 000 16902	AM COIL AN75-871390
5109	9965 000 16903	10,7MHZ MS3A
5110	9965 000 16903	10,7MHZ MS3A
5111	9965 000 16904	AHK7-850978
5112	9965 000 16905	AHK7-850981
5114	9965 000 16905	AHK7-850981
5119	9965 000 16906	KHI7-855142
5123	9965 000 16907	OHK7-850977
5130	9965 000 16908	FT10-878842
5131	9965 000 16908	FT10-878842
L704	9965 000 16910	220µH (4X5)
X1	9965 000 16911	CRA8,467M3
Y1	9965 000 16912	CRA12,0M3
	9965 000 16913	75KHZ/12,5pF

- DIODES -

6103	5322 130 34337	BAV99
6105	9965 000 07240	HN1V02H
6130	9965 000 16914	ISV228
6131	9965 000 16914	ISV228
6181	5322 130 34337	BAV99
6182	9340 255 30135	BAS216
6183	9340 386 90115	BZX284-C11
D601	5322 130 34337	BAV99
D602	5322 130 34337	BAV99
D603	9340 255 30135	BAS216
D604	9965 000 16915	HZ4B2
D605	9965 000 16915	HZ4B2
D606	5322 130 34337	BAV99
D702	9965 000 16915	HZ4B2
D801	9965 000 16916	DIODE 6,2V
D802	9965 000 16917	DIODE 5,6V
D803	4822 130 30621	1N4148
D804	4822 130 30621	1N4148
D805	9965 000 16918	4,7V 1/2W
D810	4822 130 30621	1N4148
D812	4822 130 30621	1N4148
D814	4822 130 30621	1N4148
D816	4822 130 30621	1N4148
D817	4822 130 30621	1N4148
D819	4822 130 30621	1N4148
D835	4822 130 31438	1N4001G
D836	4822 130 31438	1N4001G
D837	4822 130 31438	1N4001G
D838	4822 130 31438	1N4001G
D840	9965 000 16916	DIODE 6,2V
DISP	9965 000 16919	LED DISPLAY

- IC & TRANSISTORS -

7101	9351 740 80557	TEA5757HV1
7102	4822 130 42131	BF550
7111	5322 130 42755	BC847C
7180	4822 130 60373	BC856B
7181	5322 130 42755	BC847C
7182	5322 130 42755	BC847C
7183	5322 130 42755	BC847C
IC60	9965 000 16920	PT6955
IC60	9965 000 16921	P87C54X2BBD
IC60	9322 143 49668	M24C01-RDW6
IC70	9965 000 16922	SAA7824HL
IC70	9965 000 16923	MM1469AH
IC90	5322 209 83002	TDA2822M
Q601	4822 130 61311	2SA1162Y
Q603	9965 000 16924	2SC2712-GR

ELECTRICAL PARTSLIST**- IC & TRANSISTORS -**

Q604	4822 130 42615	BC817-40
Q701	9965 000 16927	KTC-9014C
Q704	9965 000 16928	KTC-8050C
Q705	9965 000 16926	2SB764
Q801	9965 000 16927	KTC-9014C
Q802	9965 000 16927	KTC-9014C
Q803	9965 000 04928	ON4986
Q804	9965 000 04928	ON4986
Q805	9965 000 04928	ON4986
Q806	9965 000 04928	ON4986
Q807	9965 000 16927	KTC-9014C
Q808	9965 000 16927	KTC-9014C
Q809	9965 000 16927	KTC-9014C
Q810	9965 000 16927	KTC-9014C
Q811	9965 000 16928	KTC-8050C
Q812	9965 000 16925	KTC-8550D
Q813	9965 000 16927	KTC-9014C
Q814	9965 000 16929	KTC-9015C
Q815	9965 000 16927	KTC-9014C
Q818	9965 000 16926	2SB764
Q819	9965 000 16927	KTC-9014C
Q820	4822 130 40981	BC337-25
Q821	4822 130 40981	BC337-25
Q841	9965 000 16928	KTC-8050C

Note: Only these parts mentioned in the list are normal service parts.