

2007. 9. 19 PSPU-J706A Rev1.0
EAX41678701/1 2300KEG026A-F

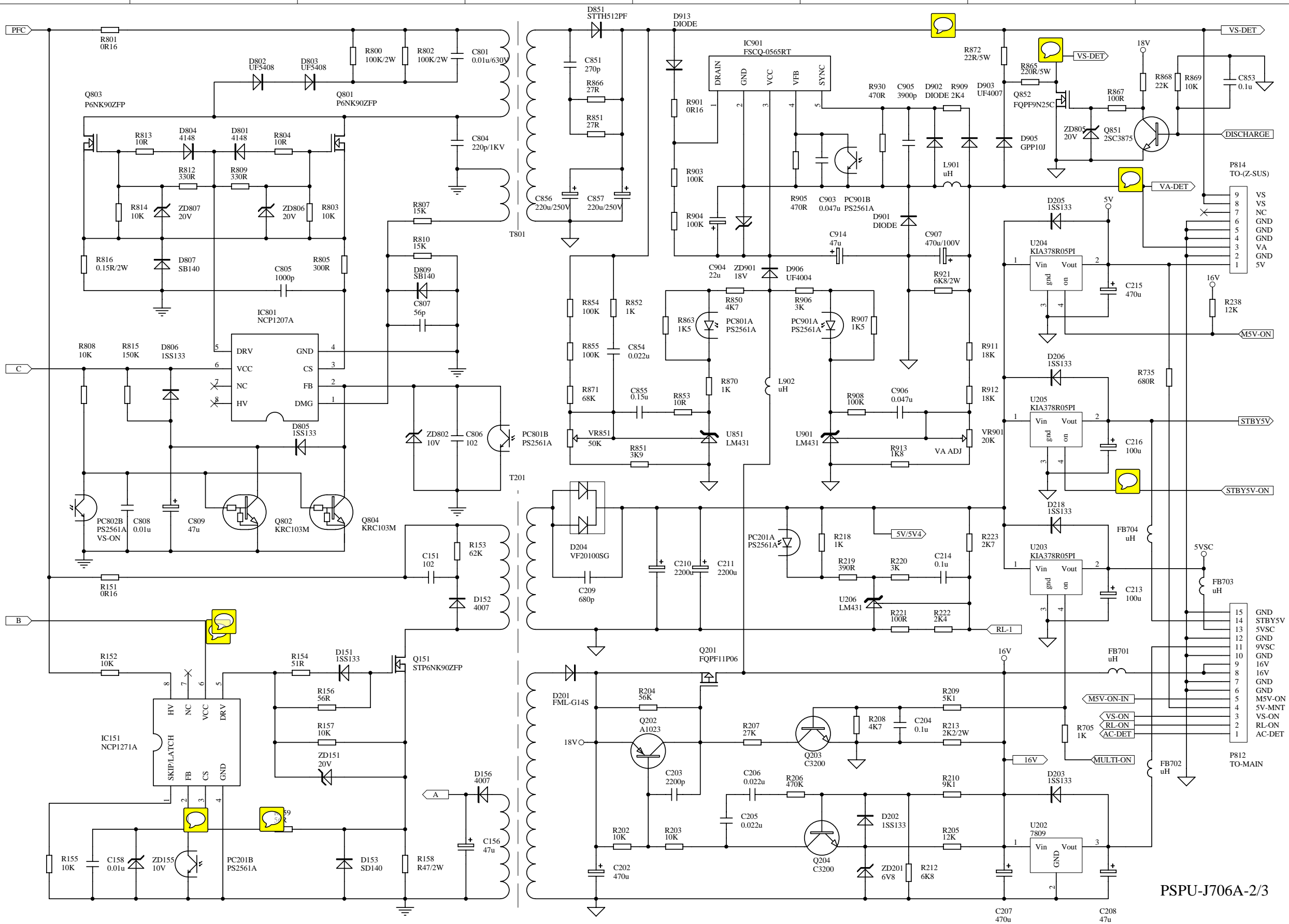

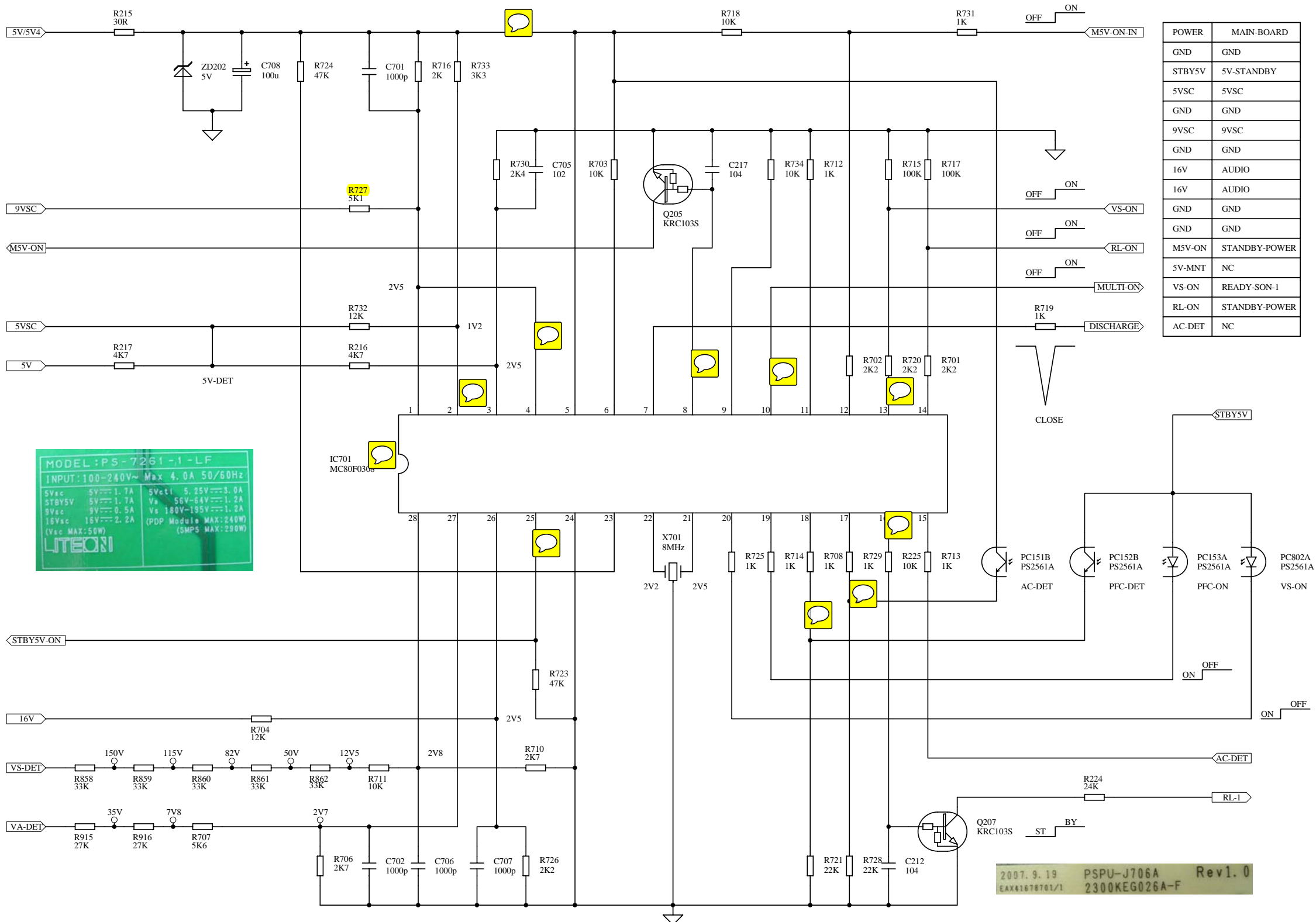

PSPU-J706A-2/3



POWER	MAIN-BOARD
GND	GND
STBY5V	5V-STANDBY
5VSC	5VSC
GND	GND
9VSC	9VSC
GND	GND
16V	AUDIO
16V	AUDIO
GND	GND
GND	GND
MSV-ON	STANDBY-POWER
5V-MNT	NC
VS-ON	READY-SON-1
RL-ON	STANDBY-POWER
AC-DET	NC

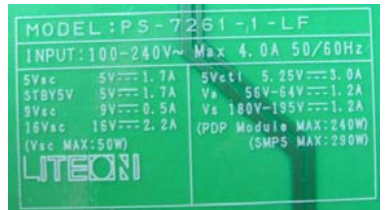

2007. 9. 19 PSPU-J706A Rev. 0
 EAX41678701/1 2300KEG026A-F