



LG

Life's Good

North/Latin America
Europe/Africa
Asia/Oceania

Internal Use Only

<http://aic.lgservice.com>
<http://eic.lgservice.com>
<http://biz.lgservice.com>

LED LCD TV

SERVICE MANUAL

CHASSIS : LM93B

MODEL : 24MN42A

24MN42A-PMN

M2442A

M2442A-PMN

CAUTION

BEFORE SERVICING THE CHASSIS,
READ THE SAFETY PRECAUTIONS IN THIS MANUAL.



CONTENTS

CONTENTS	2
SAFETY PRECAUTIONS	3
SERVICING PRECAUTIONS	4
SPECIFICATION	6
ADJUSTMENT INSTRUCTION	8
TROUBLE SHOOTING GUIDE.....	12
BLOCK DIAGRAM	23
EXPLODED VIEW	24
SCHEMATIC CIRCUIT DIAGRAM	

SAFETY PRECAUTIONS

IMPORTANT SAFETY NOTICE

Many electrical and mechanical parts in this chassis have special safety-related characteristics. These parts are identified by \triangle in the Schematic Diagram and Exploded View.

It is essential that these special safety parts should be replaced with the same components as recommended in this manual to prevent Shock, Fire, or other Hazards.

Do not modify the original design without permission of manufacturer.

General Guidance

An **isolation Transformer should always be used** during the servicing of a receiver whose chassis is not isolated from the AC power line. Use a transformer of adequate power rating as this protects the technician from accidents resulting in personal injury from electrical shocks.

It will also protect the receiver and its components from being damaged by accidental shorts of the circuitry that may be inadvertently introduced during the service operation.

If any fuse (or Fusible Resistor) in this TV receiver is blown, replace it with the specified.

When replacing a high wattage resistor (Oxide Metal Film Resistor, over 1 W), keep the resistor 10 mm away from PCB.

Keep wires away from high voltage or high temperature parts.

Before returning the receiver to the customer,

always perform an **AC leakage current check** on the exposed metallic parts of the cabinet, such as antennas, terminals, etc., to be sure the set is safe to operate without damage of electrical shock.

Leakage Current Cold Check(Antenna Cold Check)

With the instrument AC plug removed from AC source, connect an electrical jumper across the two AC plug prongs. Place the AC switch in the on position, connect one lead of ohm-meter to the AC plug prongs tied together and touch other ohm-meter lead in turn to each exposed metallic parts such as antenna terminals, phone jacks, etc.

If the exposed metallic part has a return path to the chassis, the measured resistance should be between 1 M Ω and 5.2 M Ω .

When the exposed metal has no return path to the chassis the reading must be infinite.

An other abnormality exists that must be corrected before the receiver is returned to the customer.

Leakage Current Hot Check (See below Figure)

Plug the AC cord directly into the AC outlet.

Do not use a line Isolation Transformer during this check.

Connect 1.5 K / 10 watt resistor in parallel with a 0.15 uF capacitor between a known good earth ground (Water Pipe, Conduit, etc.) and the exposed metallic parts.

Measure the AC voltage across the resistor using AC voltmeter with 1000 ohms/volt or more sensitivity.

Reverse plug the AC cord into the AC outlet and repeat AC voltage measurements for each exposed metallic part. Any voltage measured must not exceed 0.75 volt RMS which corresponds to 0.5 mA.

In case any measurement is out of the limits specified, there is possibility of shock hazard and the set must be checked and repaired before it is returned to the customer.

Leakage Current Hot Check circuit

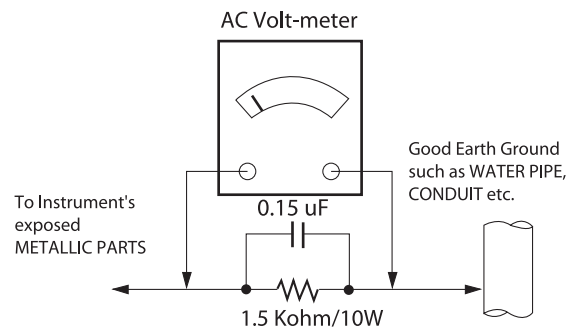

When 25A is impressed between Earth and 2nd Ground for 1 second, Resistance must be less than 0.1 Ω

*Base on Adjustment standard

SERVICING PRECAUTIONS

CAUTION: Before servicing receivers covered by this service manual and its supplements and addenda, read and follow the **SAFETY PRECAUTIONS** on page 3 of this publication.
NOTE: If unforeseen circumstances create conflict between the following servicing precautions and any of the safety precautions on page 3 of this publication, always follow the safety precautions. Remember: Safety First.

General Servicing Precautions

1. Always unplug the receiver AC power cord from the AC power source before;
 - a. Removing or reinstalling any component, circuit board module or any other receiver assembly.
 - b. Disconnecting or reconnecting any receiver electrical plug or other electrical connection.
 - c. Connecting a test substitute in parallel with an electrolytic capacitor in the receiver.
CAUTION: A wrong part substitution or incorrect polarity installation of electrolytic capacitors may result in an explosion hazard.
2. Test high voltage only by measuring it with an appropriate high voltage meter or other voltage measuring device (DVM, FETVOM, etc) equipped with a suitable high voltage probe. Do not test high voltage by "drawing an arc".
3. Do not spray chemicals on or near this receiver or any of its assemblies.
4. Unless specified otherwise in this service manual, clean electrical contacts only by applying the following mixture to the contacts with a pipe cleaner, cotton-tipped stick or comparable non-abrasive applicator; 10 % (by volume) Acetone and 90 % (by volume) isopropyl alcohol (90 % - 99 % strength)
CAUTION: This is a flammable mixture.
Unless specified otherwise in this service manual, lubrication of contacts is not required.
5. Do not defeat any plug/socket B+ voltage interlocks with which receivers covered by this service manual might be equipped.
6. Do not apply AC power to this instrument and/or any of its electrical assemblies unless all solid-state device heat sinks are correctly installed.
7. Always connect the test receiver ground lead to the receiver chassis ground before connecting the test receiver positive lead.
Always remove the test receiver ground lead last.
8. Use with this receiver only the test fixtures specified in this service manual.
CAUTION: Do not connect the test fixture ground strap to any heat sink in this receiver.

Electrostatically Sensitive (ES) Devices

Some semiconductor (solid-state) devices can be damaged easily by static electricity. Such components commonly are called Electrostatically Sensitive (ES) Devices. Examples of typical ES devices are integrated circuits and some field-effect transistors and semiconductor "chip" components. The following techniques should be used to help reduce the incidence of component damage caused by static by static electricity.

1. Immediately before handling any semiconductor component or semiconductor-equipped assembly, drain off any electrostatic charge on your body by touching a known earth ground. Alternatively, obtain and wear a commercially available discharging wrist strap device, which should be removed to prevent potential shock reasons prior to applying power to the unit under test.

2. After removing an electrical assembly equipped with ES devices, place the assembly on a conductive surface such as aluminum foil, to prevent electrostatic charge buildup or exposure of the assembly.
3. Use only a grounded-tip soldering iron to solder or unsolder ES devices.
4. Use only an anti-static type solder removal device. Some solder removal devices not classified as "anti-static" can generate electrical charges sufficient to damage ES devices.
5. Do not use freon-propelled chemicals. These can generate electrical charges sufficient to damage ES devices.
6. Do not remove a replacement ES device from its protective package until immediately before you are ready to install it. (Most replacement ES devices are packaged with leads electrically shorted together by conductive foam, aluminum foil or comparable conductive material).
7. Immediately before removing the protective material from the leads of a replacement ES device, touch the protective material to the chassis or circuit assembly into which the device will be installed.
CAUTION: Be sure no power is applied to the chassis or circuit, and observe all other safety precautions.
8. Minimize bodily motions when handling unpackaged replacement ES devices. (Otherwise harmless motion such as the brushing together of your clothes fabric or the lifting of your foot from a carpeted floor can generate static electricity sufficient to damage an ES device.)

General Soldering Guidelines

1. Use a grounded-tip, low-wattage soldering iron and appropriate tip size and shape that will maintain tip temperature within the range or 500 °F to 600 °F.
2. Use an appropriate gauge of RMA resin-core solder composed of 60 parts tin/40 parts lead.
3. Keep the soldering iron tip clean and well tinned.
4. Thoroughly clean the surfaces to be soldered. Use a mall wire-bristle (0.5 inch, or 1.25 cm) brush with a metal handle. Do not use freon-propelled spray-on cleaners.
5. Use the following unsoldering technique
 - a. Allow the soldering iron tip to reach normal temperature. (500 °F to 600 °F)
 - b. Heat the component lead until the solder melts.
 - c. Quickly draw the melted solder with an anti-static, suction-type solder removal device or with solder braid.
CAUTION: Work quickly to avoid overheating the circuit board printed foil.
6. Use the following soldering technique.
 - a. Allow the soldering iron tip to reach a normal temperature (500 °F to 600 °F)
 - b. First, hold the soldering iron tip and solder the strand against the component lead until the solder melts.
 - c. Quickly move the soldering iron tip to the junction of the component lead and the printed circuit foil, and hold it there only until the solder flows onto and around both the component lead and the foil.
CAUTION: Work quickly to avoid overheating the circuit board printed foil.
 - d. Closely inspect the solder area and remove any excess or splashed solder with a small wire-bristle brush.

IC Remove/Replacement

Some chassis circuit boards have slotted holes (oblong) through which the IC leads are inserted and then bent flat against the circuit foil. When holes are the slotted type, the following technique should be used to remove and replace the IC. When working with boards using the familiar round hole, use the standard technique as outlined in paragraphs 5 and 6 above.

Removal

1. Desolder and straighten each IC lead in one operation by gently prying up on the lead with the soldering iron tip as the solder melts.
2. Draw away the melted solder with an anti-static suction-type solder removal device (or with solder braid) before removing the IC.

Replacement

1. Carefully insert the replacement IC in the circuit board.
2. Carefully bend each IC lead against the circuit foil pad and solder it.
3. Clean the soldered areas with a small wire-bristle brush. (It is not necessary to reapply acrylic coating to the areas).

"Small-Signal" Discrete Transistor Removal/Replacement

1. Remove the defective transistor by clipping its leads as close as possible to the component body.
2. Bend into a "U" shape the end of each of three leads remaining on the circuit board.
3. Bend into a "U" shape the replacement transistor leads.
4. Connect the replacement transistor leads to the corresponding leads extending from the circuit board and crimp the "U" with long nose pliers to insure metal to metal contact then solder each connection.

Power Output, Transistor Device

Removal/Replacement

1. Heat and remove all solder from around the transistor leads.
2. Remove the heat sink mounting screw (if so equipped).
3. Carefully remove the transistor from the heat sink of the circuit board.
4. Insert new transistor in the circuit board.
5. Solder each transistor lead, and clip off excess lead.
6. Replace heat sink.

Diode Removal/Replacement

1. Remove defective diode by clipping its leads as close as possible to diode body.
2. Bend the two remaining leads perpendicular y to the circuit board.
3. Observing diode polarity, wrap each lead of the new diode around the corresponding lead on the circuit board.
4. Securely crimp each connection and solder it.
5. Inspect (on the circuit board copper side) the solder joints of the two "original" leads. If they are not shiny, reheat them and if necessary, apply additional solder.

Fuse and Conventional Resistor

Removal/Replacement

1. Clip each fuse or resistor lead at top of the circuit board hollow stake.
2. Securely crimp the leads of replacement component around notch at stake top.

3. Solder the connections.

CAUTION: Maintain original spacing between the replaced component and adjacent components and the circuit board to prevent excessive component temperatures.

Circuit Board Foil Repair

Excessive heat applied to the copper foil of any printed circuit board will weaken the adhesive that bonds the foil to the circuit board causing the foil to separate from or "lift-off" the board. The following guidelines and procedures should be followed whenever this condition is encountered.

At IC Connections

To repair a defective copper pattern at IC connections use the following procedure to install a jumper wire on the copper pattern side of the circuit board. (Use this technique only on IC connections).

1. Carefully remove the damaged copper pattern with a sharp knife. (Remove only as much copper as absolutely necessary).
2. Carefully scratch away the solder resist and acrylic coating (if used) from the end of the remaining copper pattern.
3. Bend a small "U" in one end of a small gauge jumper wire and carefully crimp it around the IC pin. Solder the IC connection.
4. Route the jumper wire along the path of the out-away copper pattern and let it overlap the previously scraped end of the good copper pattern. Solder the overlapped area and clip off any excess jumper wire.

At Other Connections

Use the following technique to repair the defective copper pattern at connections other than IC Pins. This technique involves the installation of a jumper wire on the component side of the circuit board.

1. Remove the defective copper pattern with a sharp knife. Remove at least 1/4 inch of copper, to ensure that a hazardous condition will not exist if the jumper wire opens.
2. Trace along the copper pattern from both sides of the pattern break and locate the nearest component that is directly connected to the affected copper pattern.
3. Connect insulated 20-gauge jumper wire from the lead of the nearest component on one side of the pattern break to the lead of the nearest component on the other side. Carefully crimp and solder the connections.

CAUTION: Be sure the insulated jumper wire is dressed so the it does not touch components or sharp edges.

SPECIFICATION

NOTE : Specifications and others are subject to change without notice for improvement.

1. Application range

This spec sheet is applied to the TV used LM93B chassis.

2. Requirement for Test

Each part is tested as below without special appointment.

- 1) Temperature: 25 °C ± 5 °C(77 °F ± 9 °F), CST: 40 °C ± 5 °C
- 2) Relative Humidity: 65 % ± 10 %
- 3) Power Voltage
: Standard input voltage (AC 100-240 V~, 50/60 Hz)
* Standard Voltage of each products is marked by models.
- 4) Specification and performance of each parts are followed each drawing and specification by part number in accordance with BOM.
- 5) The receiver must be operated for about 5 minutes prior to the adjustment.

3. Test method

- 1) Performance: LGE TV test method followed
- 2) Demanded other specification
 - Safety : CE, IEC specification
 - EMC : CE, IEC

4. General Specification

4.1. RGB-PC

No.	Item		Specification				Remarks
1	Supported Sync. Type		Separate Sync.(RGB), SOG				
2	Operating Frequency		Analog	Horizontal	30 ~ 69 kHz		
				Vertical	56 ~ 61 Hz		
3	Operating Frequency		Analog	Max	1366×768 @ 60Hz		
				Recommend	1366×768 @ 60Hz		
4	Input Voltage		Voltage :100 – 240 Vac, 50 or 60 Hz				
5	Inrush Current		Cold Start : 50 A, Hot : 120 A				
6	Operating Condition		Sync (H/V)	Video	LED	Wattage	RGB
	Power S/W On	On mode	On/On	Active	Off	50(Max)	
			On/On	Active		30(Typ.)	
	Power S/W On	Sleep mode	Off/On	Off	Blanking	1W	
On/Off							
Power S/W Off	Off mode	-	Off	Red	0.5W	Just operate power key and remote controller power button.	
7	MTBF		30,000 HRS with 90 % Confidence level				Lamp Life : 30,000 Hours(min)
8	Using Altitude		5,000 m (for Reliability) 3,000m(for FOS)				
9	Operating Environment		Temp : 10 °C ~ 35 °C Humidity : 20 % ~ 80 %				
10	Storage Environment		Temp : -10 °C ~ 60 °C non condensing Humidity : 5 % ~ 90 % non condensing				

4.2. TV

No.	Item	Specification		Remarks	
1.	Market	Central and South America			
2.	Broadcasting system	NTSC, PAL-M/N			
3.	Available Channel (Revision 21: 10.12.08)	BAND	NTSC		China(DK)
		VHF	2~13	VHF/UHF	C1~C62
		UHF	14~69	VHF/UHF	C1~C62
		CATV	1~125	CATV	S1~S41
4.	Receiving system	Upper Heterodyne			
5.	CVBS Input (1EA)	NTSC, PAL-M, PAL-N		3 System(Rear) : NTSC, PAL-M, PAL-N	
6.	RGB Input	RGB-PC		Analog(D-SUB 15Pin)	
7.	HDMI Input (1EA)	HDMI-DTV		HDMI version 1.3 ,Support HDCP	
8.	Audio Input (1EA)	CVBS		L/R Input	

5. RGB Input (PC)

No.	Resolution	H-freq(kHz)	V-freq.(Hz)	Pixel clock(MHz)	Proposed	Remark
1	640*480	31.469	59.94	25.175		
2	800*600	37.879	60.317	40.0		
3	1024*768	48.363	60.0	65.0		
4	1280*720	47.77	59.85	74.5		
5	1152*864	54.34	60.05	80		
6	1280*1024	63.981	60.02	108.0		
7	1366*768	47.71	59.79	85.5		

6. HDMI Input (DTV)

No	Resolution	H-freq(kHz)	V-freq.(kHz)	Pixel clock(MHz)	Proposed	Remarks
1	720*480	15.75	60.00	13.514	SDTV, DVD 480I(525I)	Support(not spec)
2	720*480	15.73	59.94	13.500	SDTV, DVD 480I(525I)	Support(not spec)
3	720*576	15.625	50.00	13.500	SDTV, DVD 576I(625I) 50Hz	Support(not spec)
4	720*480	31.47	59.94	27.000	SDTV 480P	
5	720*480	31.50	60.00	27.027	SDTV 480P	
6	720*576	31.25	50.00	27.000	SDTV 576P 50Hz	
7	1280*720	44.96	59.94	74.176	HDTV 720P	
8	1280*720	45.00	60.00	74.250	HDTV 720P	
9	1280*720	37.50	50.00	74.25	HDTV 720P 50Hz	
10	1920*1080	33.72	59.94	74.176	HDTV 1080I	
11	1920*1080	33.75	60.00	74.250	HDTV 1080I	
12	1920*1080	28.125	50.00	74.250	HDTV 1080I 50Hz	
13	1920*1080	67.432	59.94	148.350	HDTV 1080P	
14	1920*1080	67.5	60	148.5	HDTV 1080P	
15	1920*1080	56.250	50	148.5	HDTV 1080P 50Hz	

* HDMI jack is for AV(video signal)

ADJUSTMENT INSTRUCTION

1. Application Range

This document is applied to LM93B chassis TV which is manufactured in TV Factory or is produced on the basis of this data.

2. Designation

- (1) The adjustment is according to the order which is designated and which must be followed, according to the plan which can be changed only on agreeing.
- (2) Power adjustment : Free Voltage.
- (3) Magnetic Field Condition: Nil.
- (4) Input signal Unit: Product Specification Standard.
- (5) Reserve after operation : Above 5 Minutes (Heat Run)
 - Temperature : at 25 °C ± 5 °C
 - Relative humidity : 65 ± 10 %
 - Input voltage : 220 V, 60 Hz
- (6) Adjustment equipments: Color Analyzer (CA-210 or CA-110), Pattern Generator (MSPG-925L or Equivalent), DDC Adjustment Jig equipment, SVC remote control

- Case1 : Software version up
1. After downloading S/W by USB , TV set will reboot automatically.
 2. Push "In-stop" key.
 3. Push "Power on" key.
 4. Function inspection
 5. After function inspection, Push "In-stop" key.
- Case2 : Function check at the assembly line
1. When TV set is entering on the assembly line, Push "In-stop" key at first.
 2. Push "Power on" key for turning it on.
 - If you push "Power on" key, TV set will recover channel information by itself.
 3. After function inspection, Push "In-stop" key.

3. ADC calibration

MSPG-925 series	RGB
	Model : 60 (1024 X 768@ 60 Hz)

3.1. PC input ADC

- (1) Auto RGB Gain/Offset Adjustment
 - Convert to PC in Input-source
 - Signal equipment displays
 - Output Voltage: 700mVp-p
 - Impress Resolution XGA (1024 x 768 @ 60Hz)
 - Model: 60 in Pattern Generator (1024X768@60Hz 16 step Gray Pattern)
 - Pattern: 29 in Pattern Generator (MSPG-925 Series)



- Adjust by commanding AUTO_COLOR_ADJUST (0xF1) 0x00 0x02 instruction
- (2) Confirmation
 - We confirm to address "0xF1" in page "0xBC" of EEPROM the value is "0xAA" or not.
 - If the value is not "0xAA," we adjust once more
 - We can write the ADC values from "0x00~0x05" addresses in a page "0x0E"
- * Manual ADC process using Service Remocon. After enter Service Mode by pushing "ADJ" key, Execute "Auto-RGB" by pushing "▶" key at "Auto-RGB."

4. Adjustment items

4.1. PCB assembly adjustment items

4.1.1. Input Tool-Option, Area Option

- Option adjustment following BOM (Tool Option, Area Option)
- (1) Required Equipments
 - : Remote control for adjustment
- (2) Profile: Must be changed the option value because being different with some setting value Depend on module maker, inch and market.
- (3) Adjustment method
 - The input methods are same as other chassis. (Use IN-START key on the Adjust Remote control.)

LD93H	LGD	M2242A
Main	V1.00	UTT X
ADC-NG	EDID-NG,	NG
Tool Option	2184	
Area Option	1	

- 1) Push the IN-START key in the Adjust R/C.
- 2) Input the Option Number that was specified in the BOM, into the Shipping area.
- 3) Select "Tool Option/ Area Option" by using ▲/▼(CH+/-) key, and press the number key(0~9) consecutively
 - Ex) if the value of Tool Option1 is 7, input the data using number key "7" (If not changed the option, the input menu can differ from the model spec.)
 - * Refer to Job Expression of each main chassis ass'y (EBTxxxxxxx) for Option value

- * Before PCB check, you have to change the Tool option, Area Option and have to AC off/on (Plug out and in) (If missing this process, set can operate abnormally)
- * Never push the IN-STOP key after completing the function inspection.

4.2. S/W program download

- (1) Profile : This is for downloading the s/w to the flash memory of IC603.
- (2) Equipment
 - 1) PC
 - 2) MTK_tool program
 - 3) Download jig
 - 4) USB
- (3) Connection structure

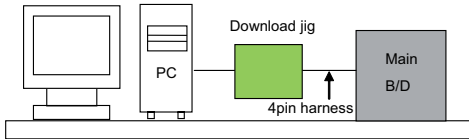

- (4) Connection condition
 - 1) IC name and circuit number : Flash Memory and IC603
 - 2) Tact time : about 2min

4.3. Download method 1

4.3.1. Preliminary steps

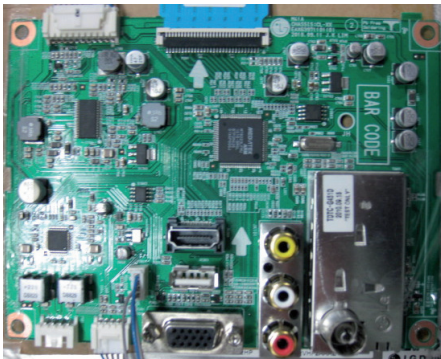

- (1) Connect the download jig to 4pin jack (P303)



- (2) Connect the PC to USB jack

4.3.2. Download steps

- (1) Execute 'ISP Tool' program in PC, then a main window will be opened

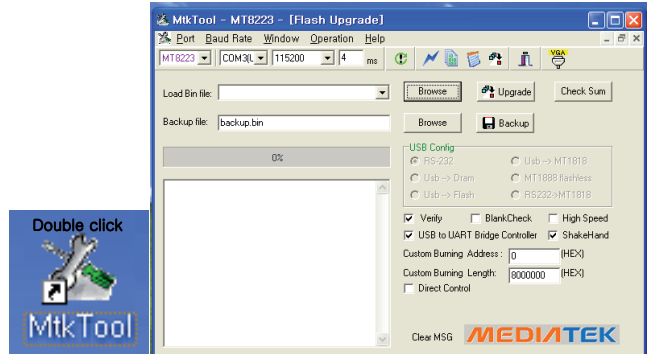

- (2) Click the Config and Change speed (MT8223, Using Port, 115200, 4ms)

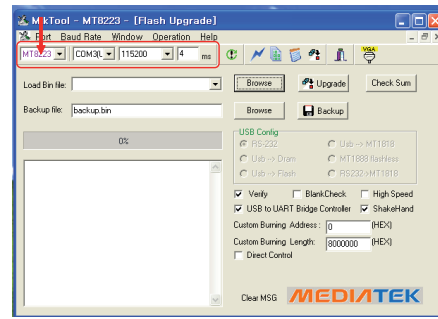

- (3) Click the connect button and confirm

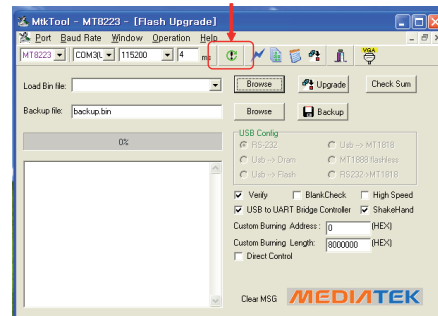

- (4) Read and write bin file
Click "(1) Browse" tab, and then load download file (XXXX. bin) by clicking and open.

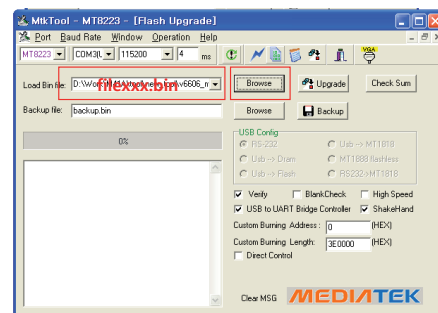

(5).Click “Upgrade” tab and set as below

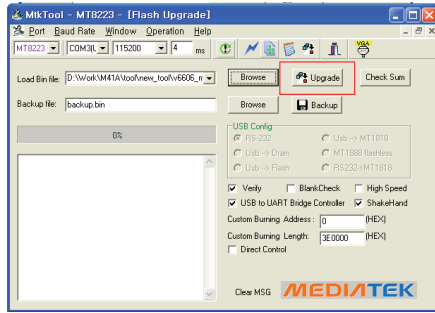

(6) After downloading, AC Power OFF and ON.

4.4. Download method 2

- 1) Connection USB memory for upgrade.(File name : Mx42A_PMN_xxxx.bin or Mx42A_PMN_xxxx.bin)
- 2) Press the IN START button.
- 3) Select the 'Upg Fw' menu
- 4) Press the ► button and wait
- 5) If the progressive bar 100% will be completed

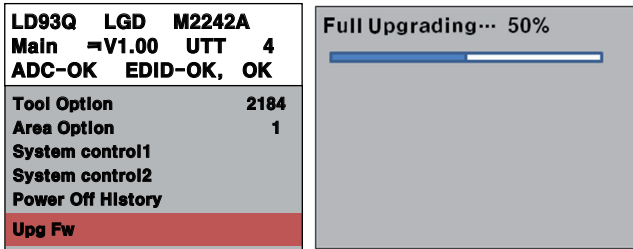

- Notice: Do not plug out USB during upgrading.

5. Check EDID and Write HDCP key

- This model is no need to write. EDID data is in Program source

5.1. EDID data

No.	Item	content	16bit Data
1	Manufacturer ID	GSM	1E6D
2	Product ID	Analog : 22867 HDMI : 22868	5953 5954
3	Year	2012	16
4	Version	Analog : 1 Digital : 1	1
5	Revision	Analog : 3 Digital : 3	3
6	Model Name	M2442A	

(1) RGB EDID Data

	0	1	2	3	4	5	6	7	8	9	A	B	C	D	E	F
00	00	FF	FF	FF	FF	FF	00	1E	6D	53	59	01	01	01	01	
10	01	16	01	03	68	34	1D	78	EA	4E	4D	A3	56	4D	9E	26
20	0E	47	4A	A1	08	00	31	40	45	40	61	40	71	40	81	00
30	81	C0	81	80	01	01	66	21	56	AA	51	00	1E	30	46	8F
40	33	00	3F	43	21	00	00	1E	00	00	00	FD	00	38	3D	1E
50	3D	09	00	0A	20	20	20	20	20	20	00	00	00	FC	00	4D
60	32	34	34	32	41	0A	20	20	20	20	20	20	20	00	00	FF
70	00	0A	20	20	20	20	20	20	20	20	20	20	20	20	00	63

(2) HDMI EDID Data

	0	1	2	3	4	5	6	7	8	9	A	B	C	D	E	F
00	00	FF	FF	FF	FF	FF	00	1E	6D	54	59	01	01	01	01	
10	01	16	01	03	80	34	1D	78	E8	4E	4D	A3	56	4D	9E	26
20	0E	47	4A	21	08	00	81	80	81	C0	71	40	B3	00	81	40
30	90	40	95	00	A9	C0	66	21	56	AA	51	00	1E	30	46	8F
40	33	00	09	25	21	00	00	1A	02	3A	80	18	71	38	2D	40
50	58	2C	45	00	09	25	21	00	00	1E	00	00	00	FD	00	38
60	3D	1E	45	0F	00	0A	20	20	20	20	20	20	20	00	00	FC
70	00	4D	32	34	34	32	41	0A	20	20	20	20	20	20	01	56

	0	1	2	3	4	5	6	7	8	9	A	B	C	D	E	F
00	02	03	19	F1	4A	90	04	03	01	14	12	05	1F	10	13	23
10	09	07	07	65	03	0C	00	10	00	02	3A	80	18	71	38	2D
20	40	58	2C	45	00	09	25	21	00	00	1A	01	1D	80	18	71
30	1C	16	20	58	2C	25	00	09	25	21	00	00	9E	01	1D	00
40	72	51	D0	1E	20	6E	28	55	00	09	25	21	00	00	1E	01
50	1D	80	D0	72	1C	16	20	10	2C	25	80	C4	8E	21	00	00
60	9E	02	3A	80	D0	72	38	2D	40	10	2C	45	20	09	25	21
70	00	00	1E	00	00	00	00	00	00	00	00	00	00	00	00	9D

- 1) All data are HEXA
- 2) Adjustable Data :
 - ** : week
 - *** : year ex) when year 2008: input “12”
 - **** : CHECK SUM (deferent along week, year)

5.2. Write HDCP key

- (1) Connect D-sub Signal Cable to D-Sub Jack
- (2) Input HDCP key with HDCP-key- in-program
- (3) HDCP Key value is stored on Main MTK IC (MTK8223) which is 0x80~0xA0 Addresses of 0x00~0x01 page (EEPROM MAP PAGE0~PAGE1 / START Addr: A0 80)
- (4) AC off/on and on HDCP button of MSPG925 and confirm whether picture is displayed or not of using MSPG925
- (5) HDCP Key value is different among the sets

6. Check of White Balance

RGB_Gains are fixed data for each model.

Insert D-sub jack (I2C) which is connected with PC for White Balance or equivalent device.

→ Total Assembly line should check whether the color coordinate(x, y) data Refer to below table were meet or not.

6.1. Required Equipment

- Remote controller for checking W/B
- Color Analyzer : CA-210
- CH: 14 (LCD MNT, Normal)
- PC (for communication through RGB)
- Pattern Generator (MSPG-925FS series)

6.2. Connecting diagram of equipment for measuring (For Automatic Adjustment)

(Method 1, using IIC, You connect RGB Cable)

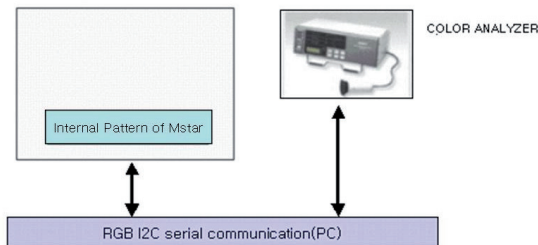

(Standard color coordinate and temperature when using the CA210 equipment)

RGB_Gains are fixed data for each model

Color Temperature	Cool	9,300k	°K	X=0.283 (±0.03) Y=0.298 (±0.03)	<Test Signal> PC Mode only Full White (100IRE)
	Warm	6,500k		X=0.313 (±0.03) Y=0.329 (±0.03)	
Color Temperature	Cool	9,300k	°K	X=0.283 (±0.03) Y=0.298 (±0.03)	<Test Signal> RF/AV/HDMI Inner pattern (216gray, 85IRE)
	Medium	8,000k	°K	X=0.295 (±0.03) Y=0.305 (±0.03)	
	Warm	6,500k	°K	X=0.313 (±0.03) Y=0.329 (±0.03)	
Luminance (cd/m ²)	Cool	Min: 170		Typ : 200	<Test Signal> (Full white, 100IRE)
	Medium	Min: 170		Typ : 200	
	Warm	Min: 170		Typ : 200	

* When doing Adjustment, Please make circumstance as below.

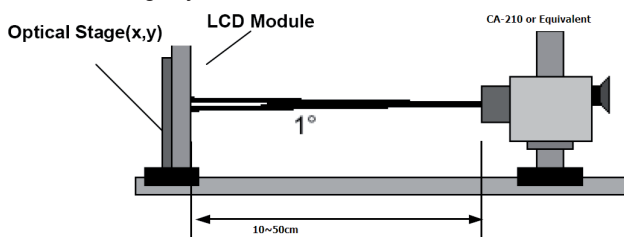

* W/B condition

- Ambient Humidity : 20 % ~ 80 %
- Ambient Temperature : 25 ± 5 °C

7. Function Check

7.1. Check display and sound

- Check input and Signal items. (cf. work instructions)
 1. TV
 2. AV (CVBS)
 3. RGB (PC : 1920 x 1080 @ 60hz)(Display only)
 4. HDMI

TROUBLE SHOOTING

1. NO POWER-Main PCBA

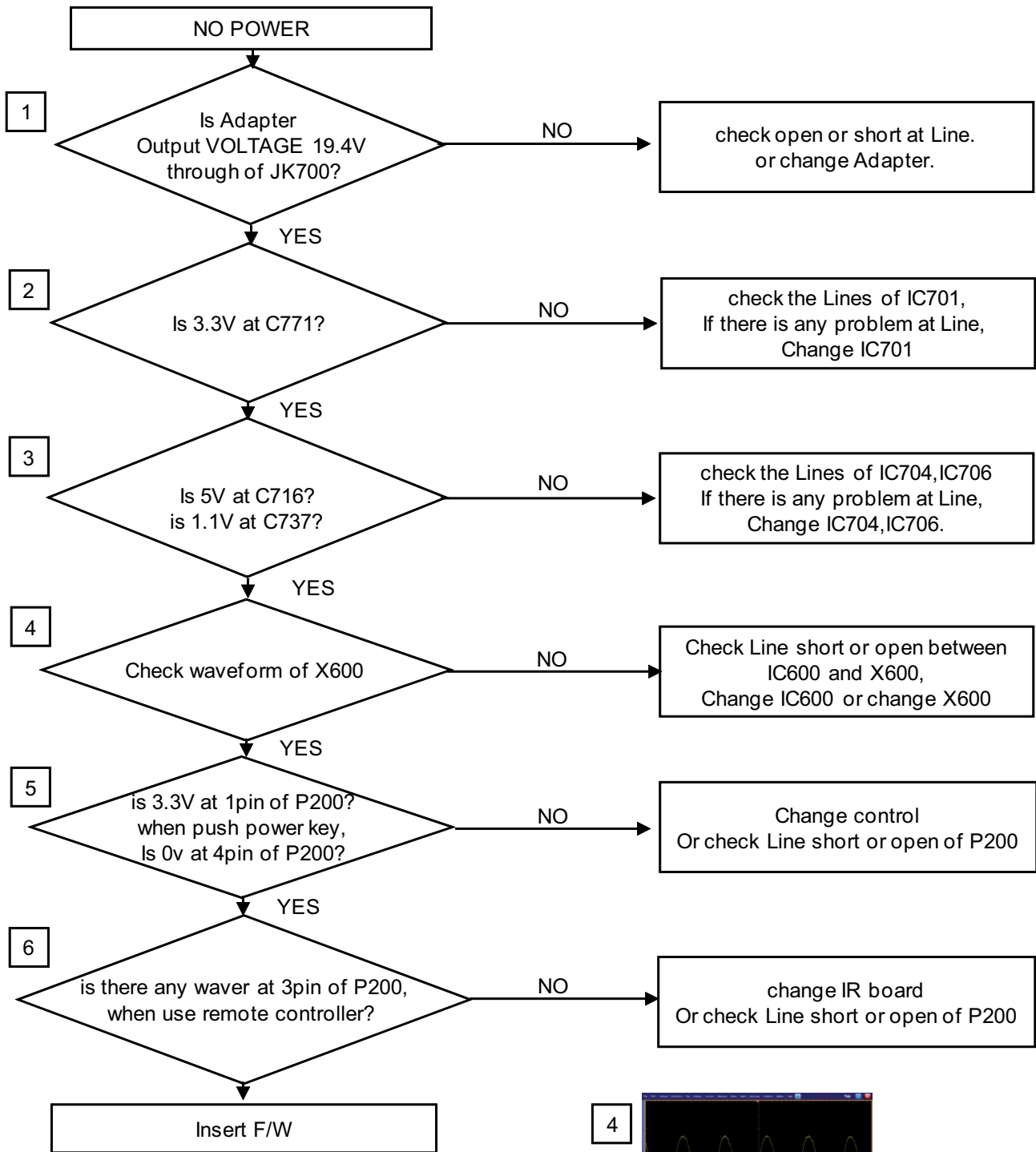

4

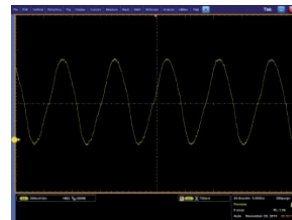

X600

2. No raster (Power LED blue, black screen)

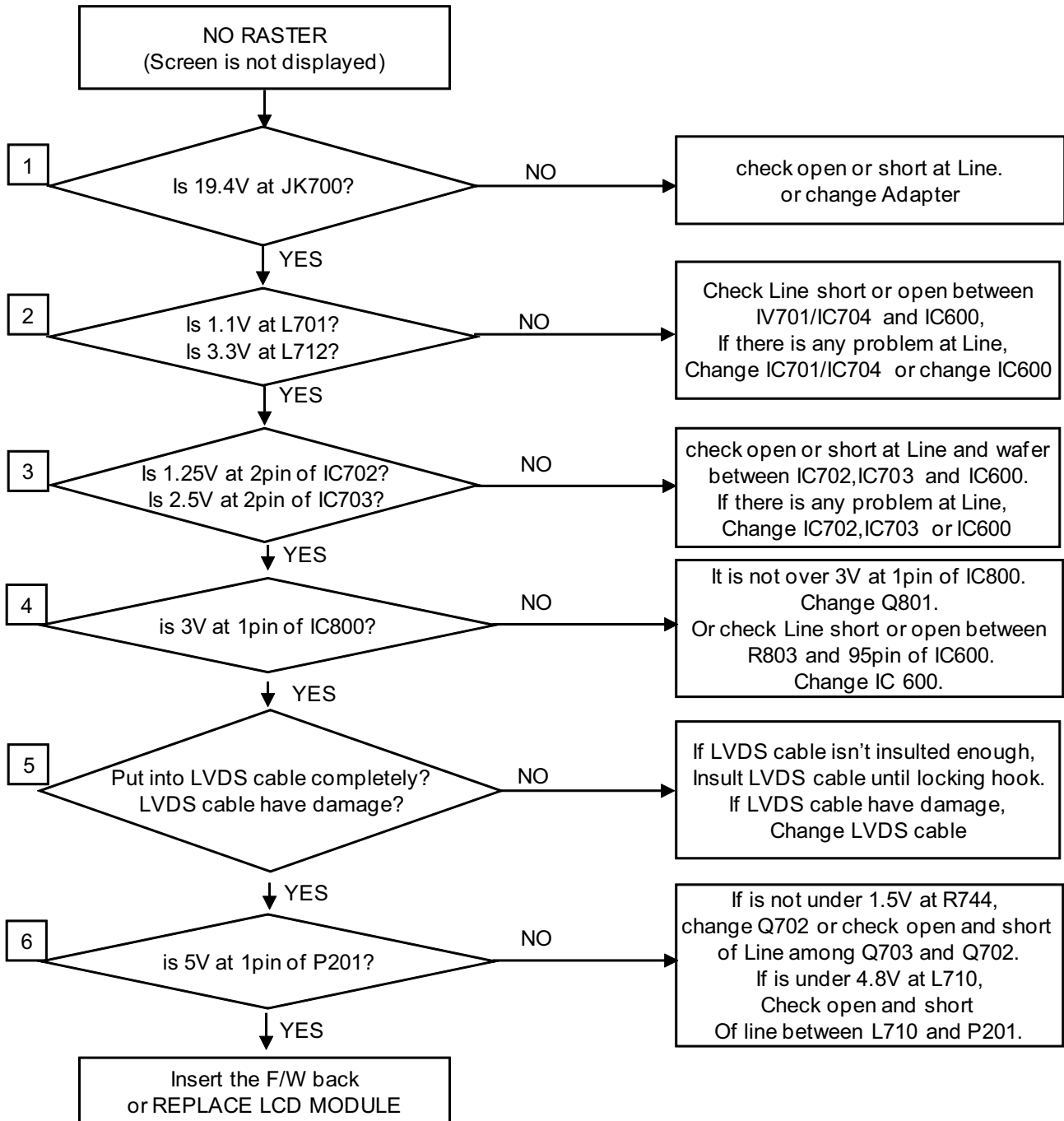

3. Abnormal/No screen (All input)-Main PCBA

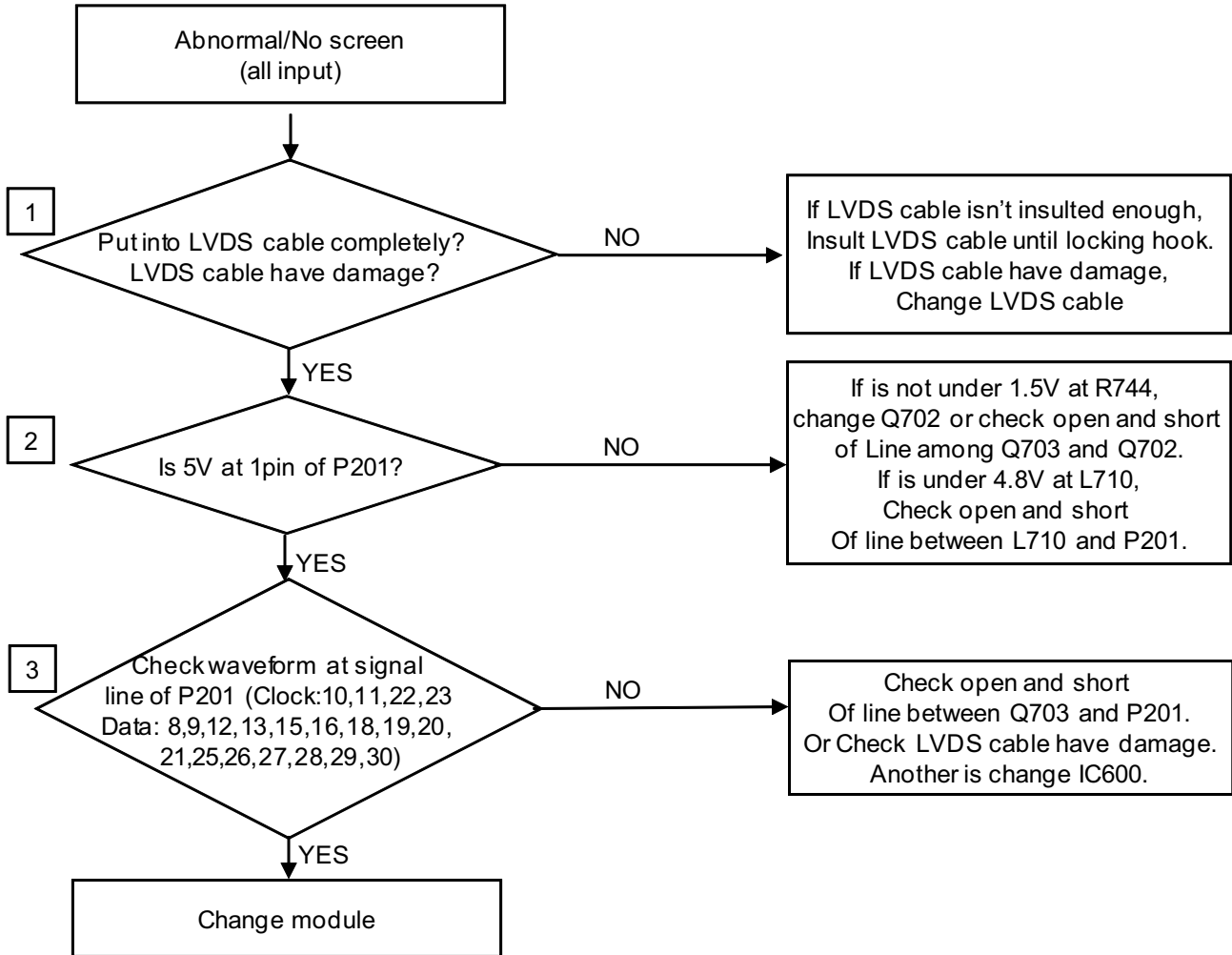

WAVEFORMS

3

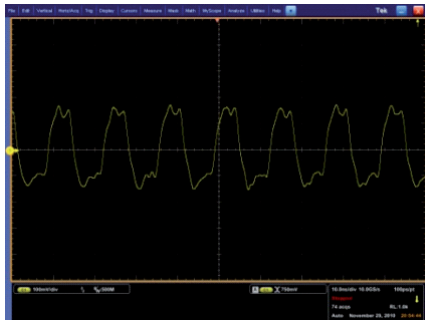

10,11,22,23Pin of P201 (Clock line)

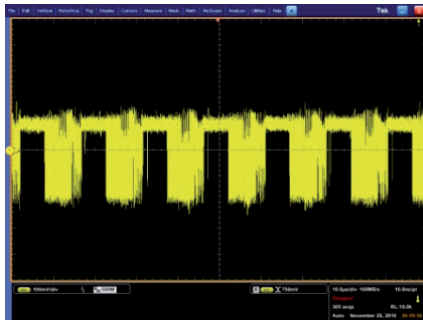

8,9,12,13,15,16,18,19,20,21, 25,26,27,28,29,30Pin of P201 (Data Line)

4. Abnormal screen (TV)-Main PCBA

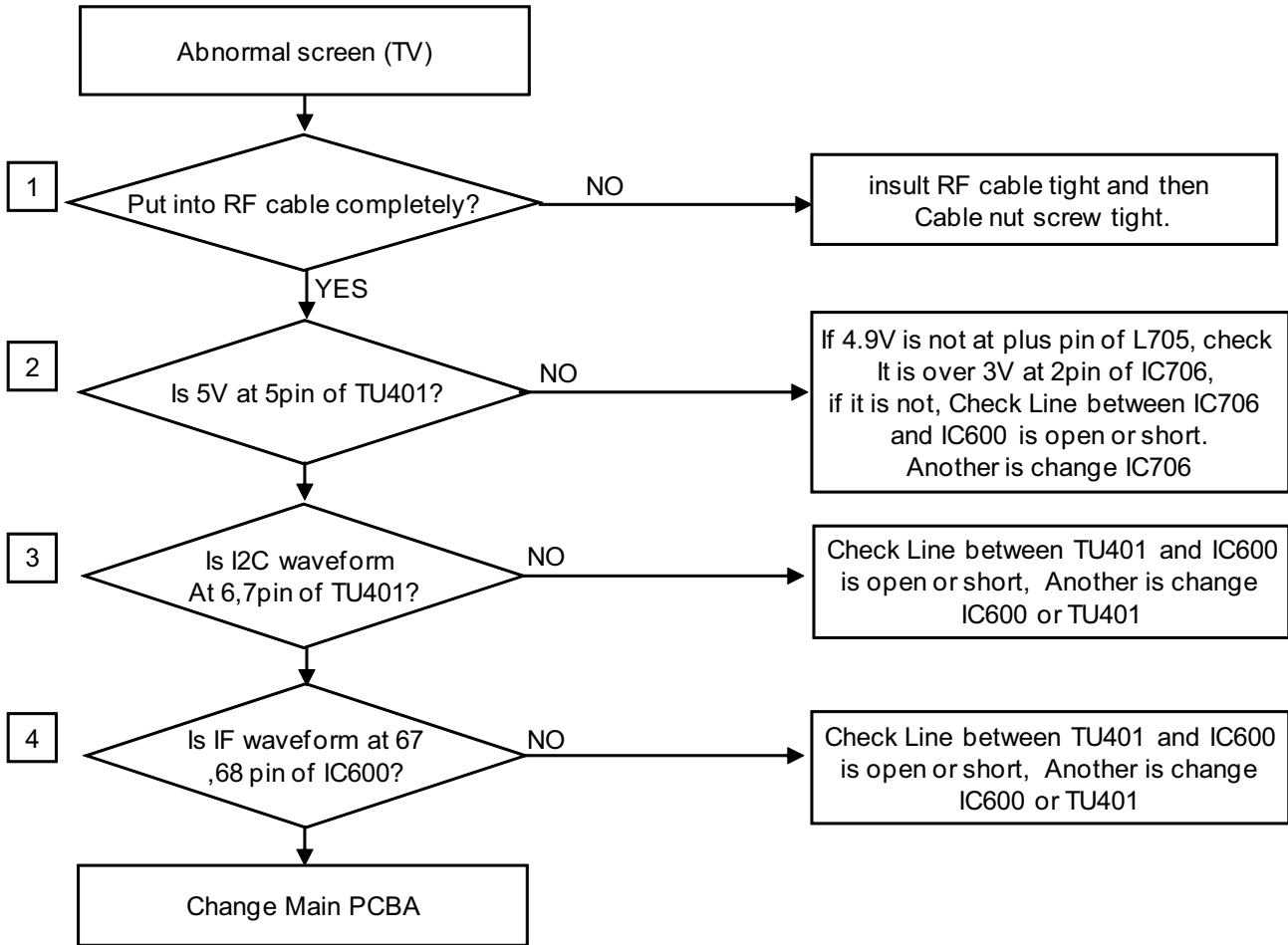

WAVEFORMS

3

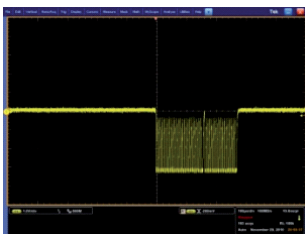

7Pin of TU401 (SCL)

4

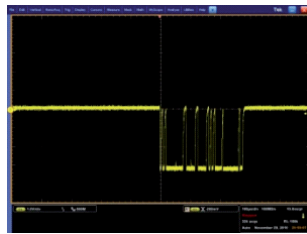

6Pin of TU401 (SDA)

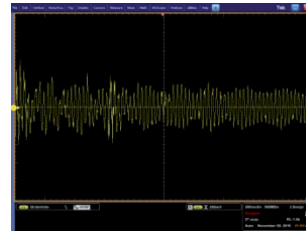

67, 68pin of IC600

5. Abnormal screen (AV)-Main PCBA

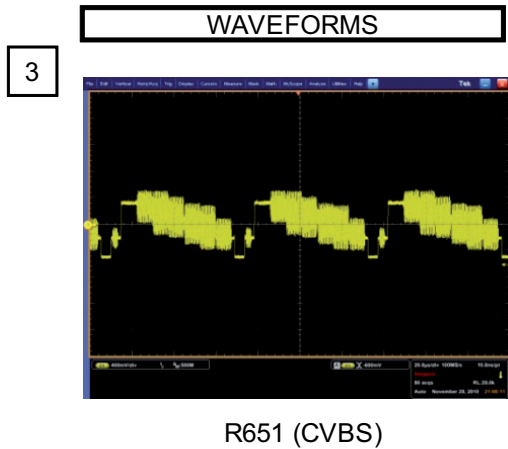
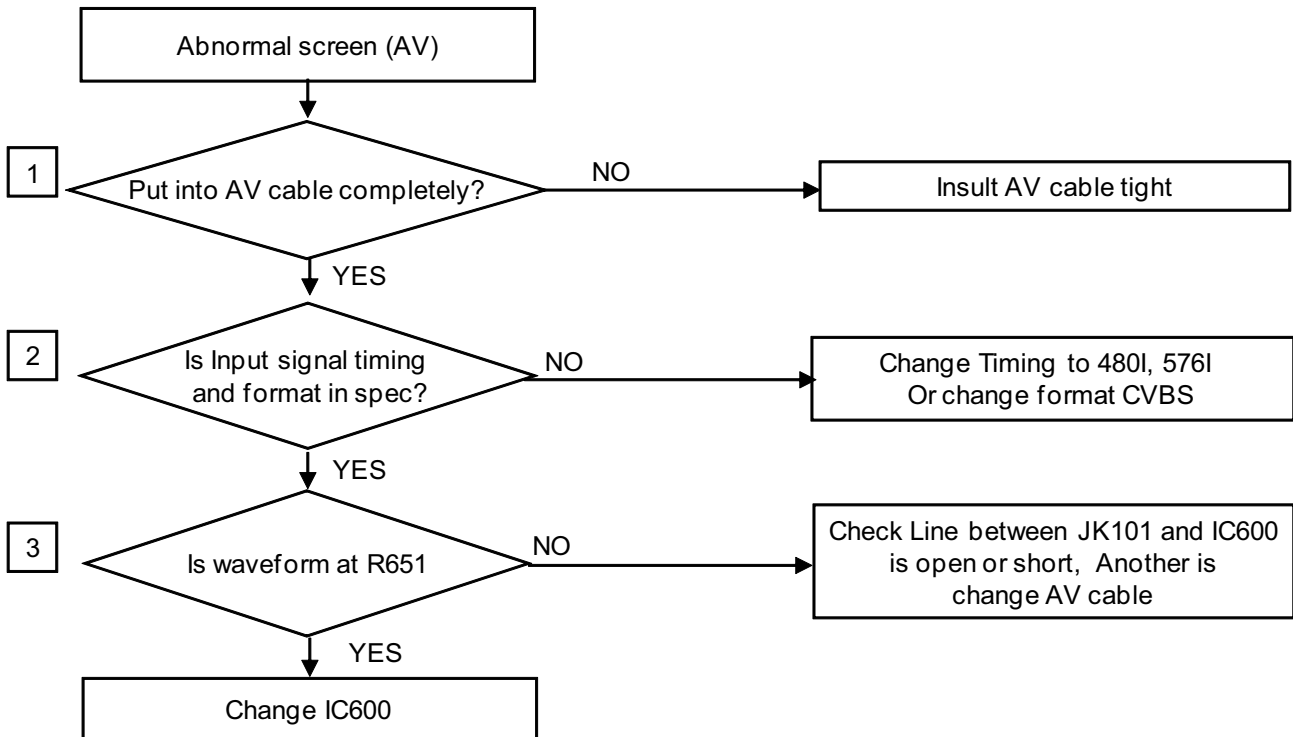

6. Abnormal screen (RGB PC)-Main PCBA

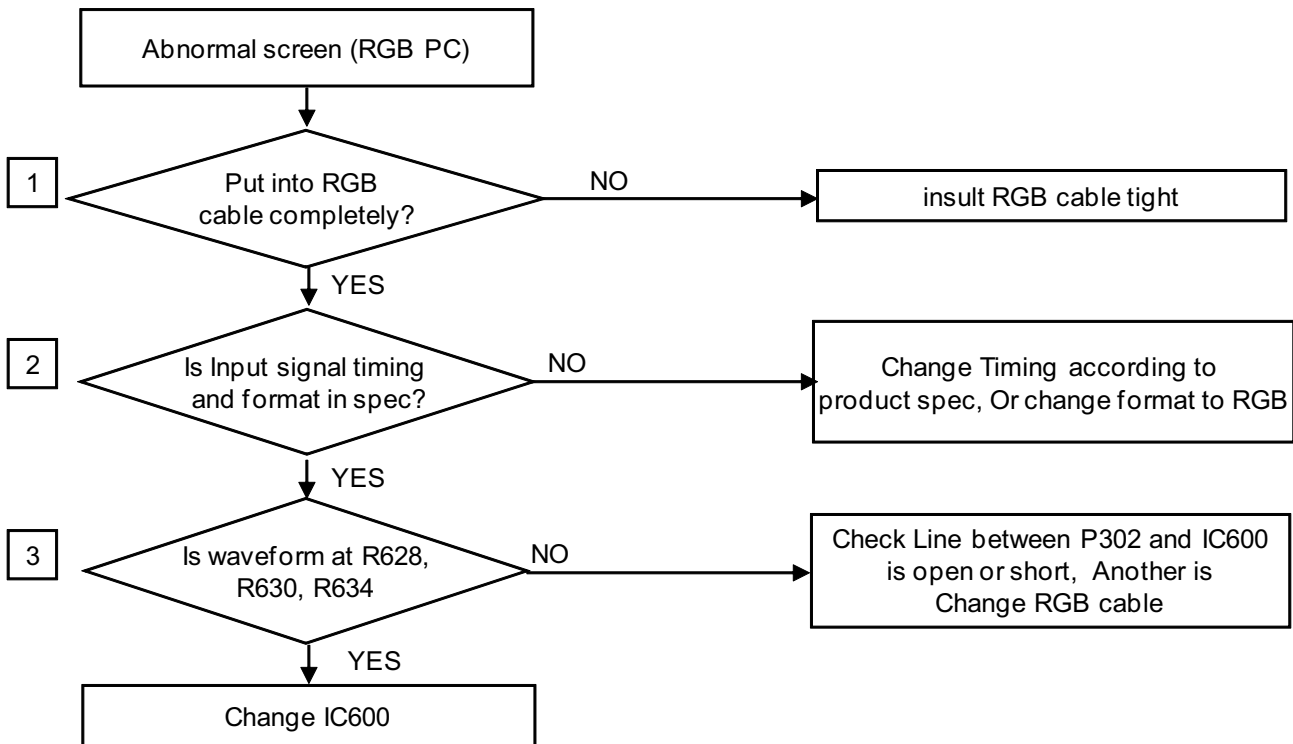

WAVEFORMS

3



R630(G)

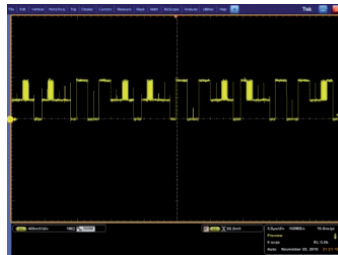

R634(R)



R628(B)

7. Abnormal screen (HDMI)-Main PCBA

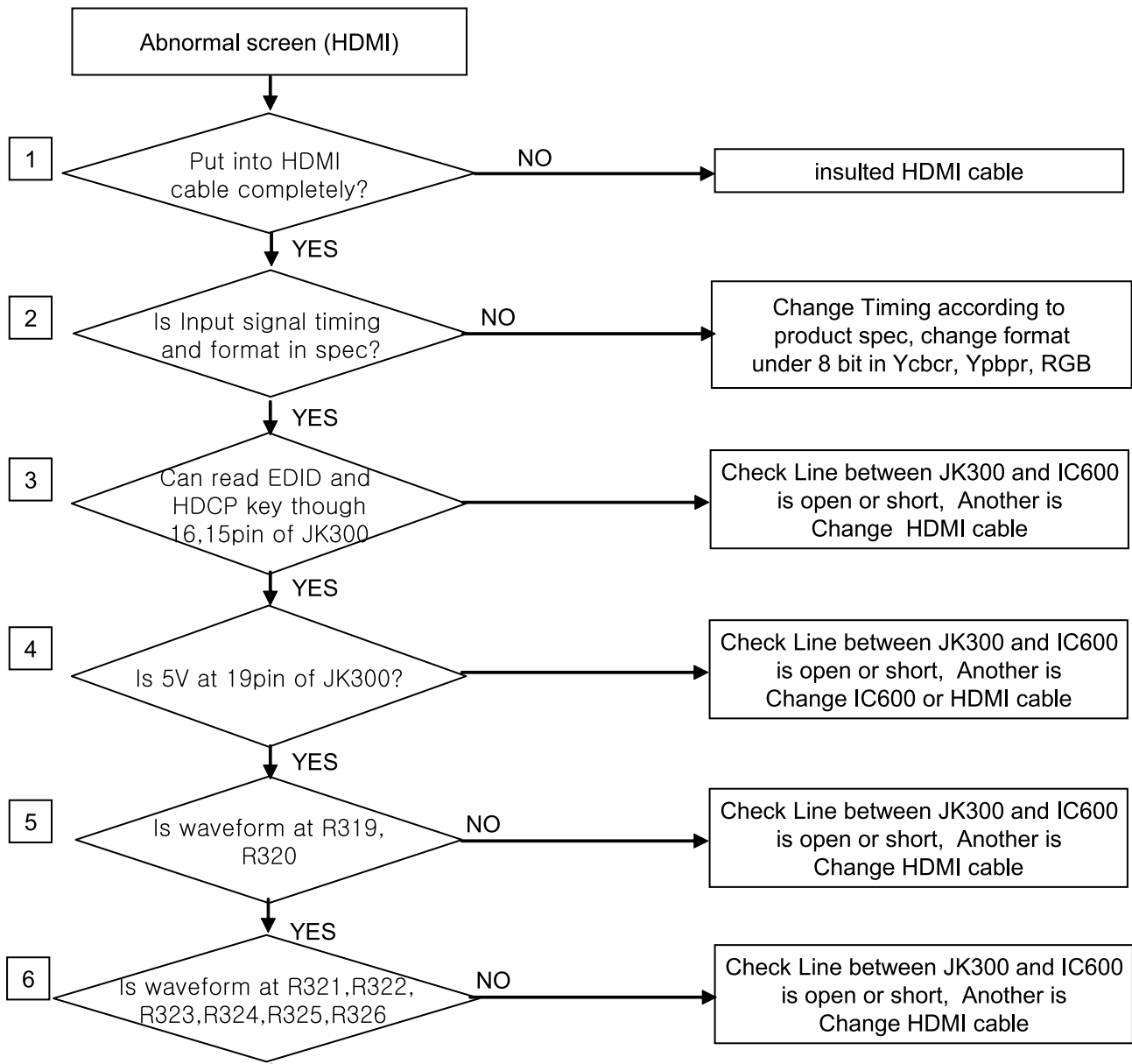

8. No sound (all source)-Main PCBA

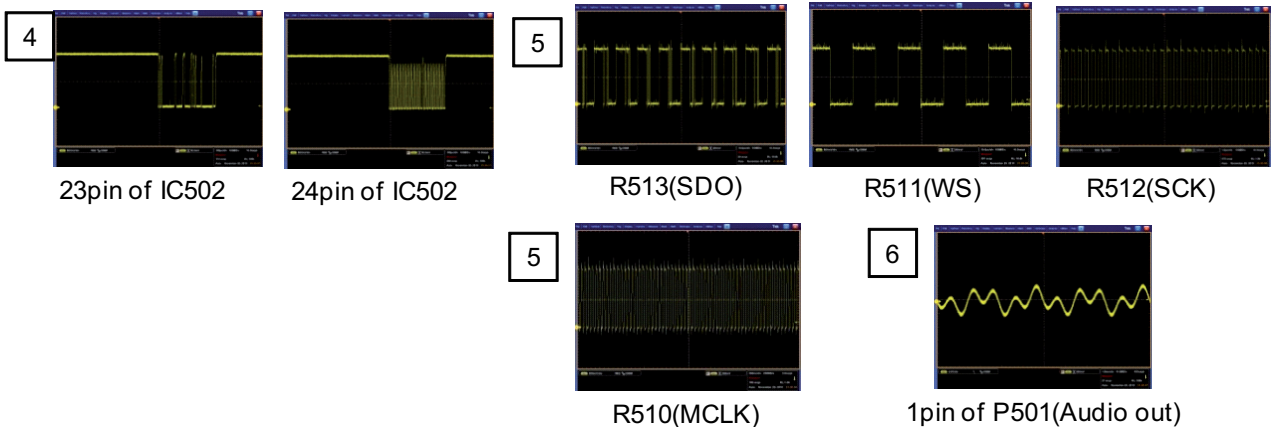
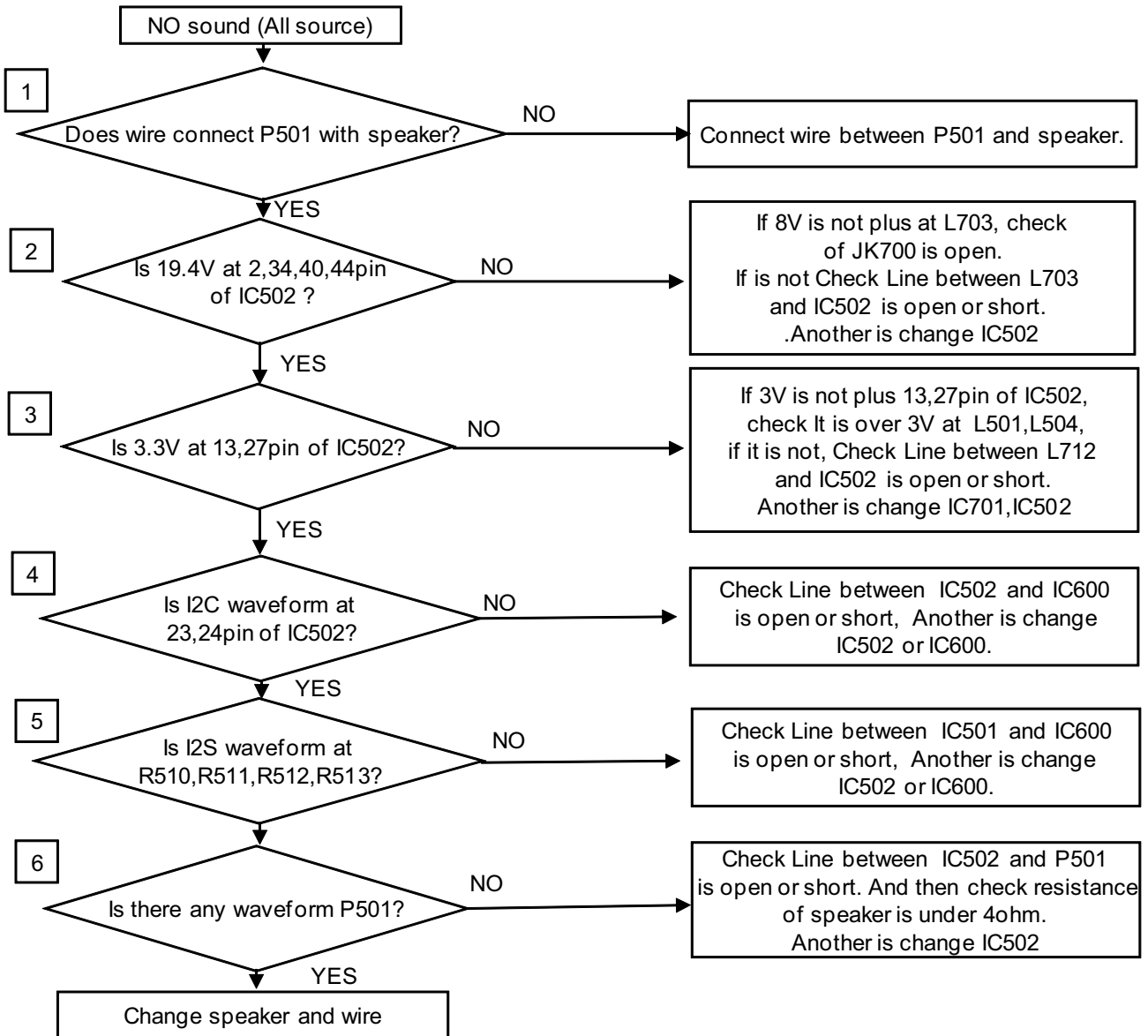

9. Abnormal sound (TV)-Main PCBA

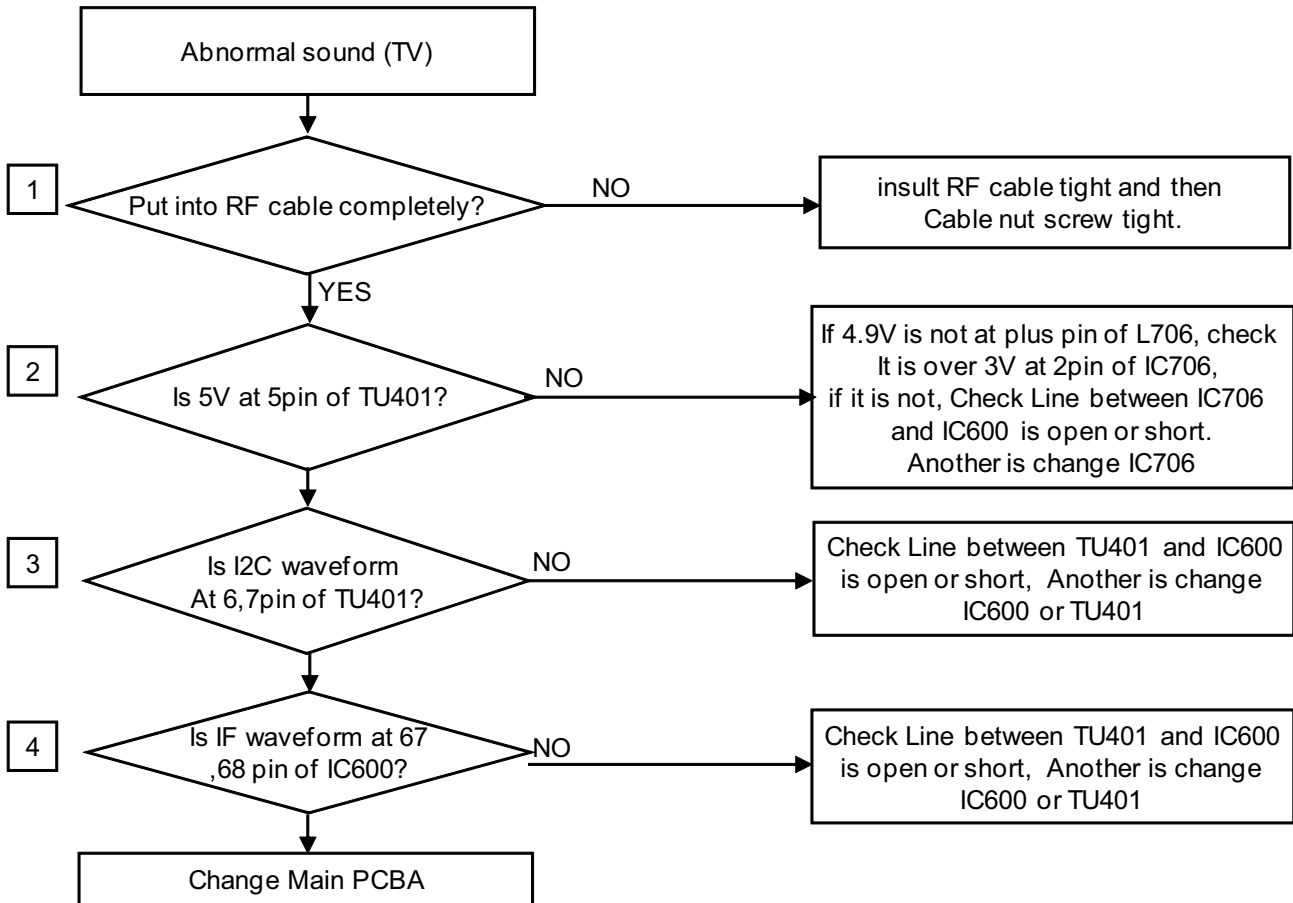

WAVEFORMS

3

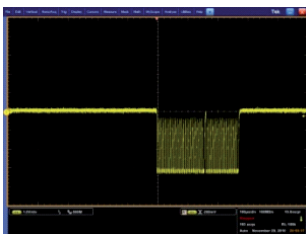

7Pin of TU401 (SCL)

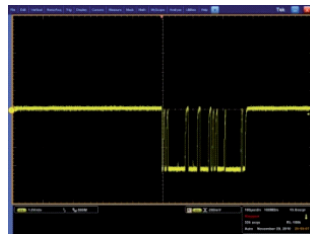

6Pin of TU401 (SDA)

4

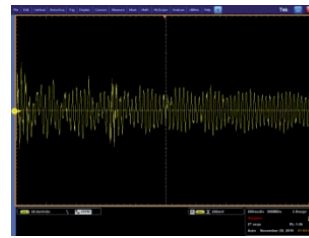

67,68 pin of IC604

10. Abnormal sound (AV)-Main PCBA

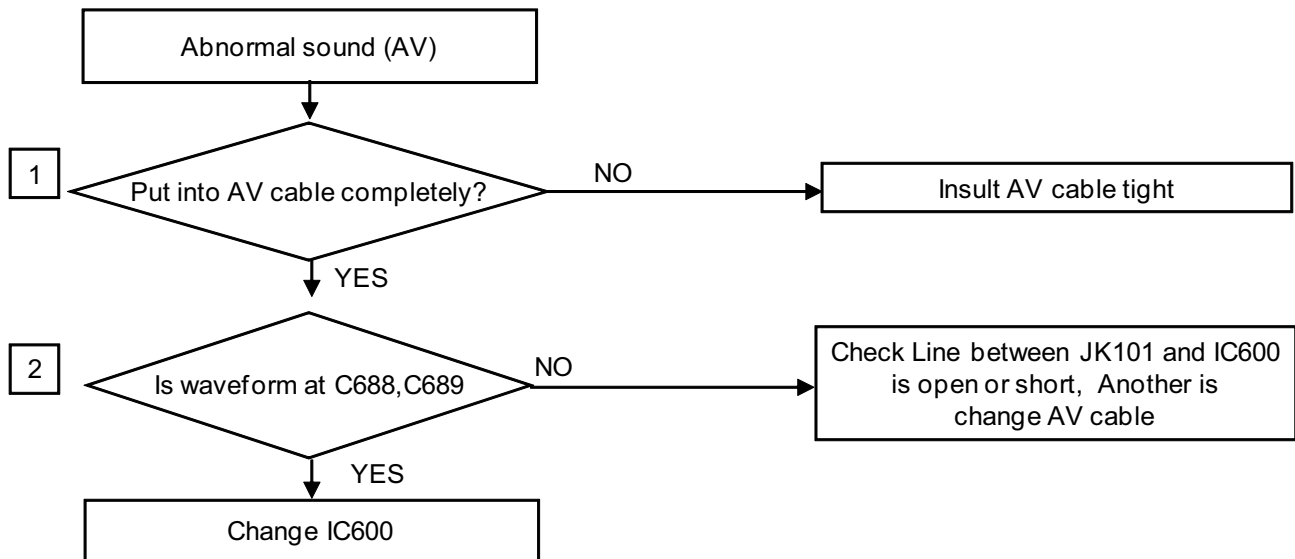

WAVEFORMS

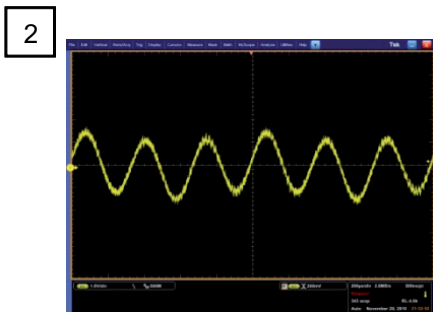

C688,C689 (audio in)

11. Abnormal sound (HDMI)-Main PCBA

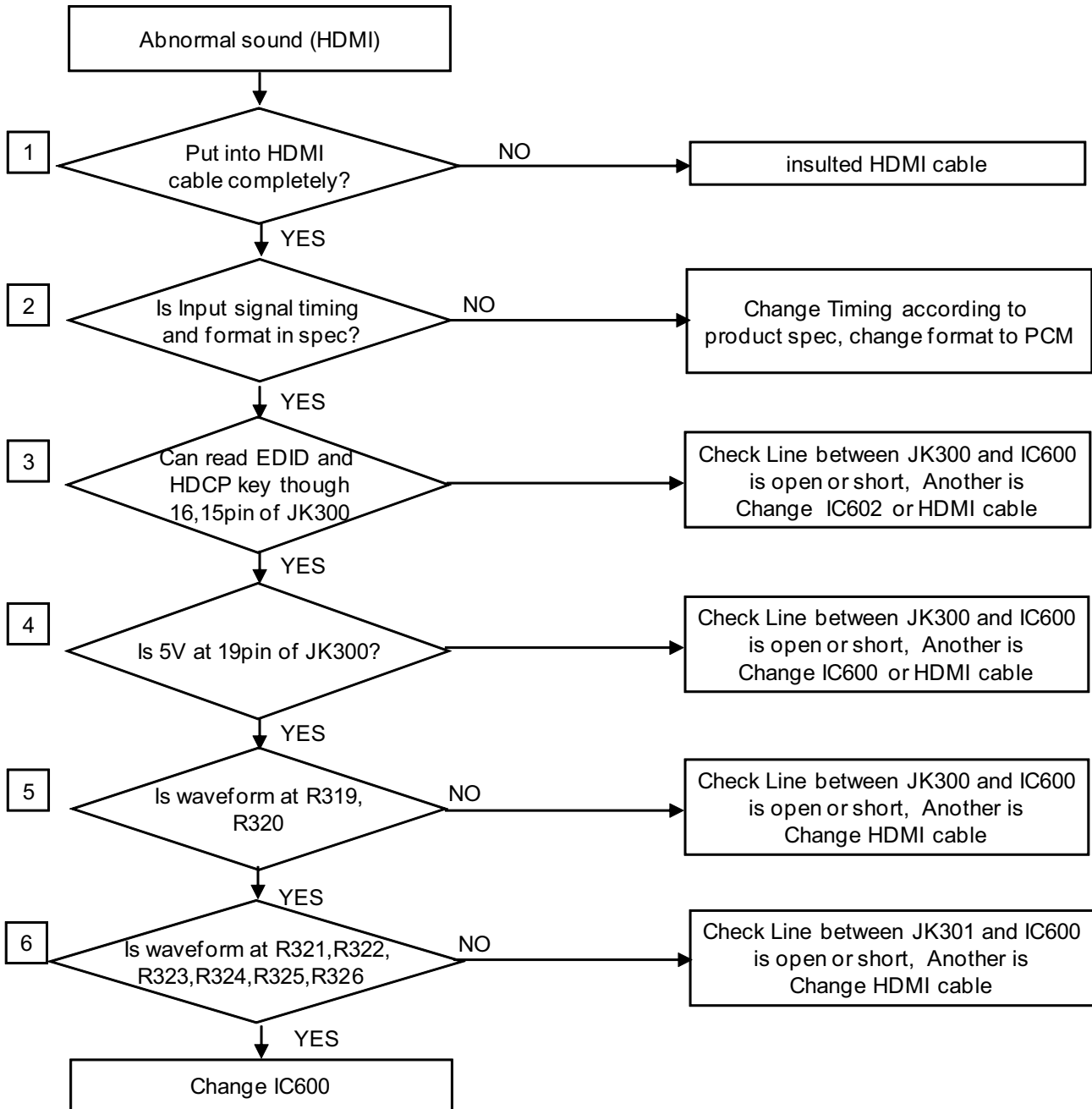

BLOCK DIAGRAM

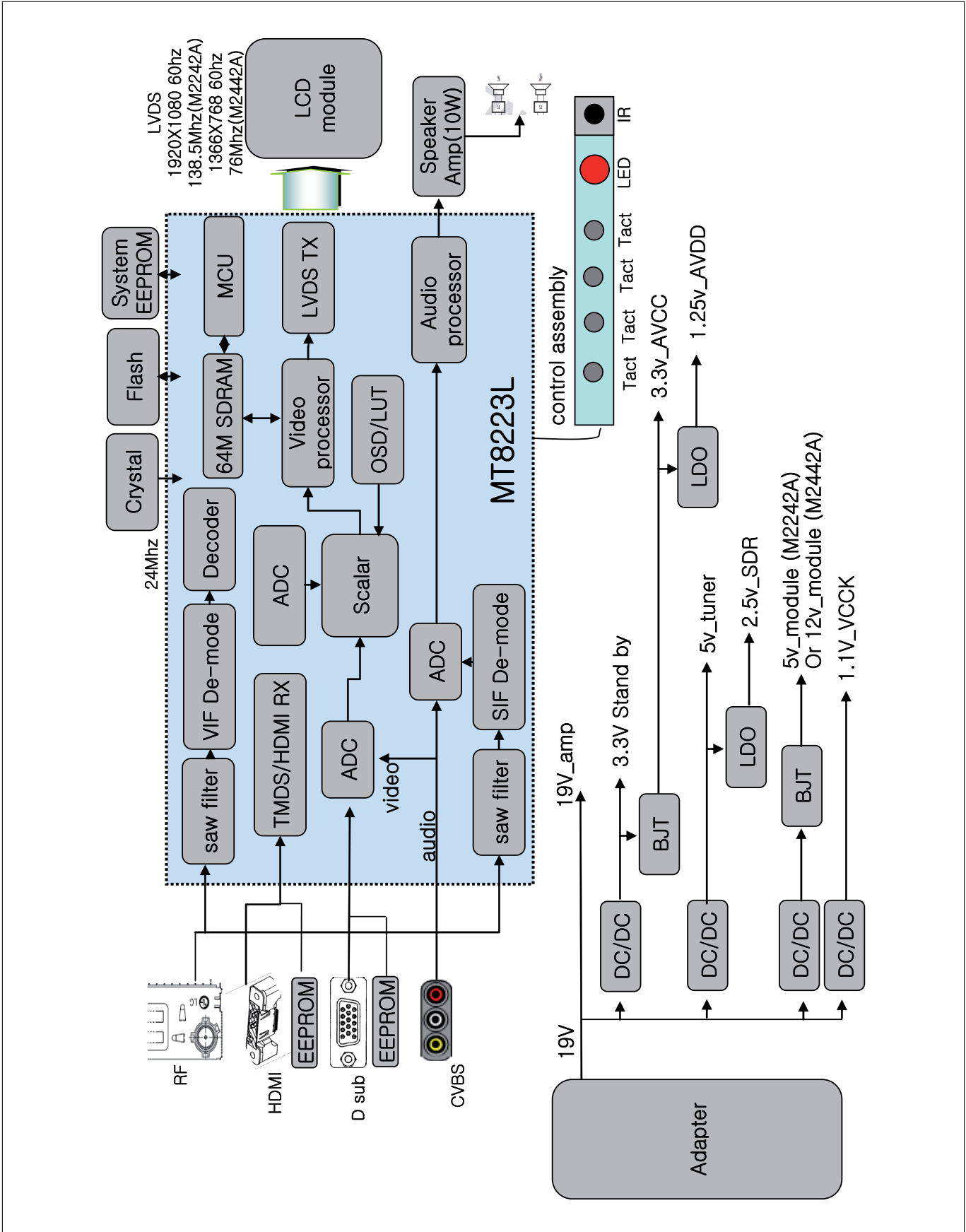

EXPLODED VIEW

IMPORTANT SAFETY NOTICE

Many electrical and mechanical parts in this chassis have special safety-related characteristics. These parts are identified by \triangle in the Schematic Diagram and EXPLODED VIEW. It is essential that these special safety parts should be replaced with the same components as recommended in this manual to prevent X-RADIATION, Shock, Fire, or other Hazards. Do not modify the original design without permission of manufacturer.

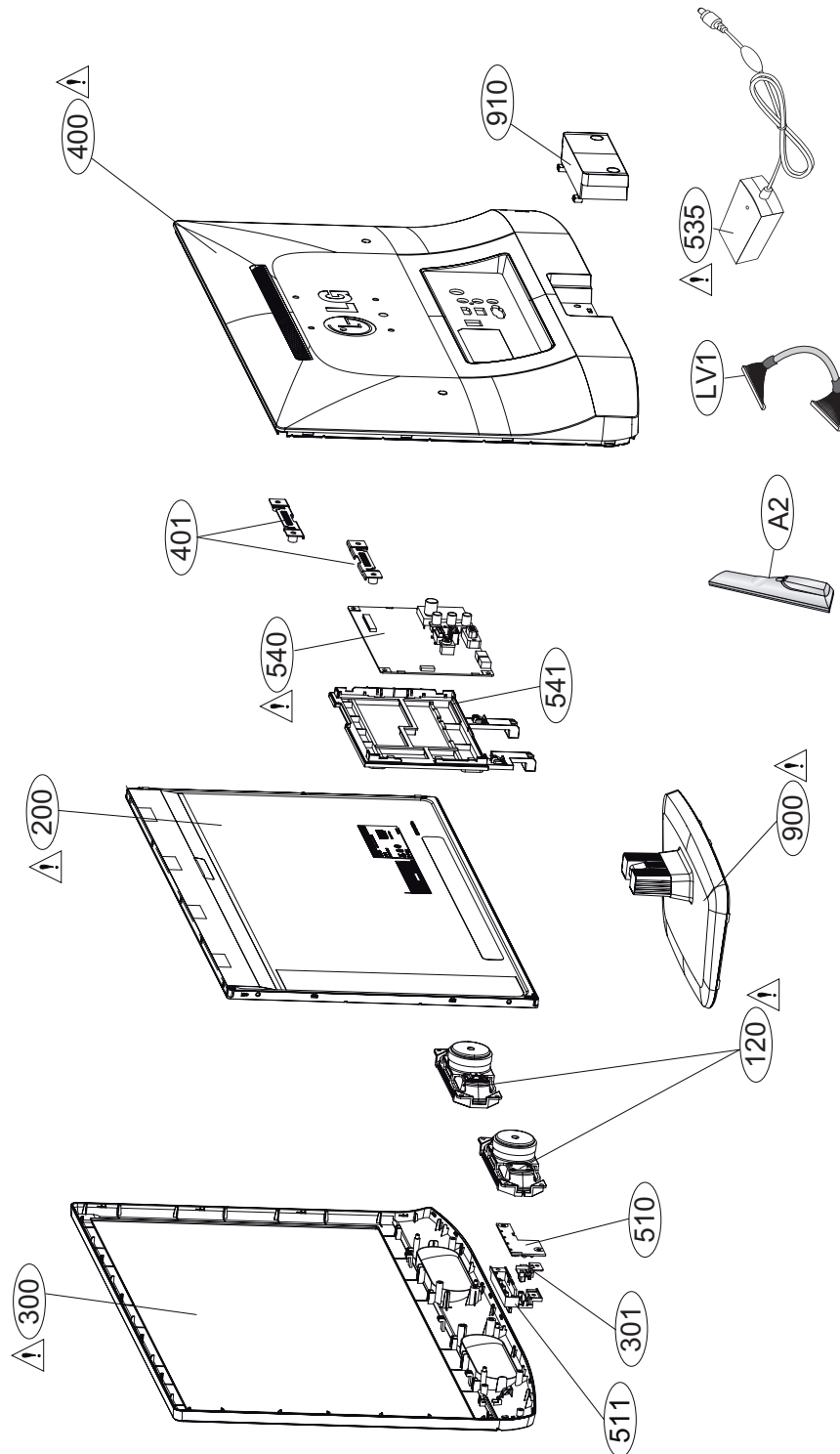

LVDS/IR

CONTROL Key
IR & LED

Zener Diode is
close to wafer

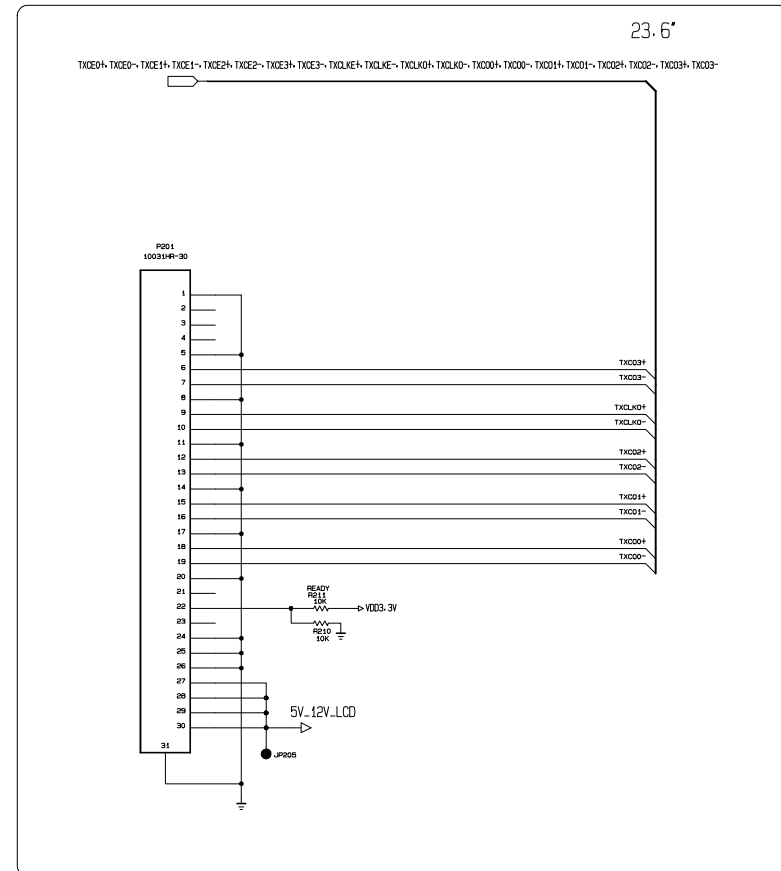
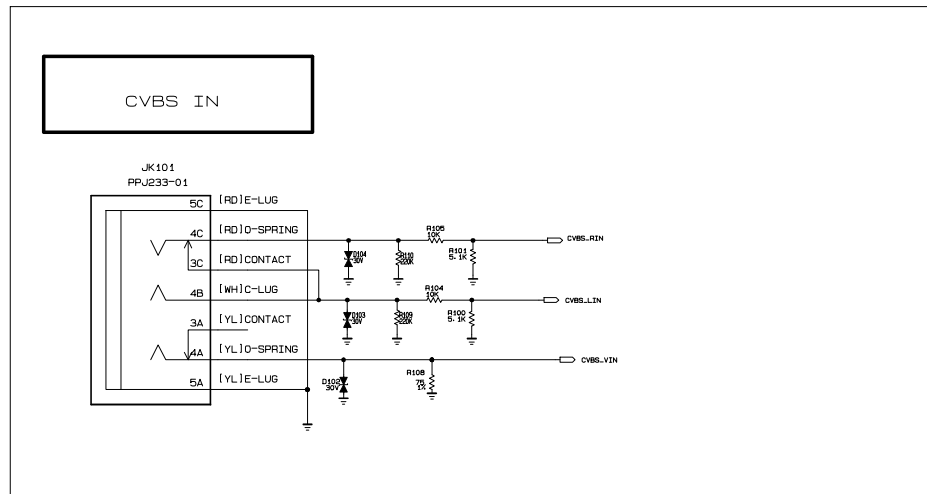
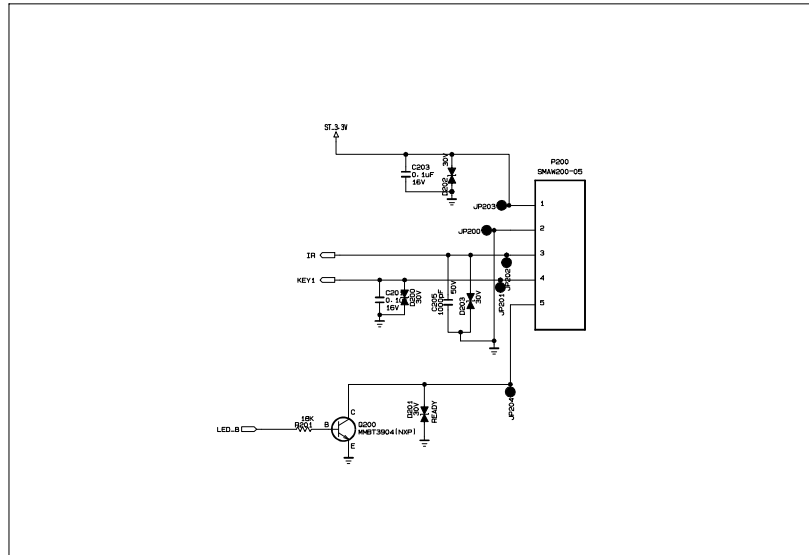

THE SYMBOL MARK OF THIS SCHEMATIC DIAGRAM INCORPORATES SPECIAL FEATURES IMPORTANT FOR PROTECTION FROM X-RADIATION. FILTRE AND ELECTRICAL SHOCK HAZARDS, WHEN SERVICING IF IS ESSENTIAL THAT ONLY MANUFACTURES SPECIFIED PARTS BE USED FOR THE CRITICAL COMPONENTS IN THE SYMBOL MARK OF THE SCHEMATIC.

SECRET
LGElectronics

LG ELECTRONICS

MODEL	EAX64892902_0	DATE	2012/07/17
BLOCK	LVDS/IR	SHEET	1/7

INTERFACE

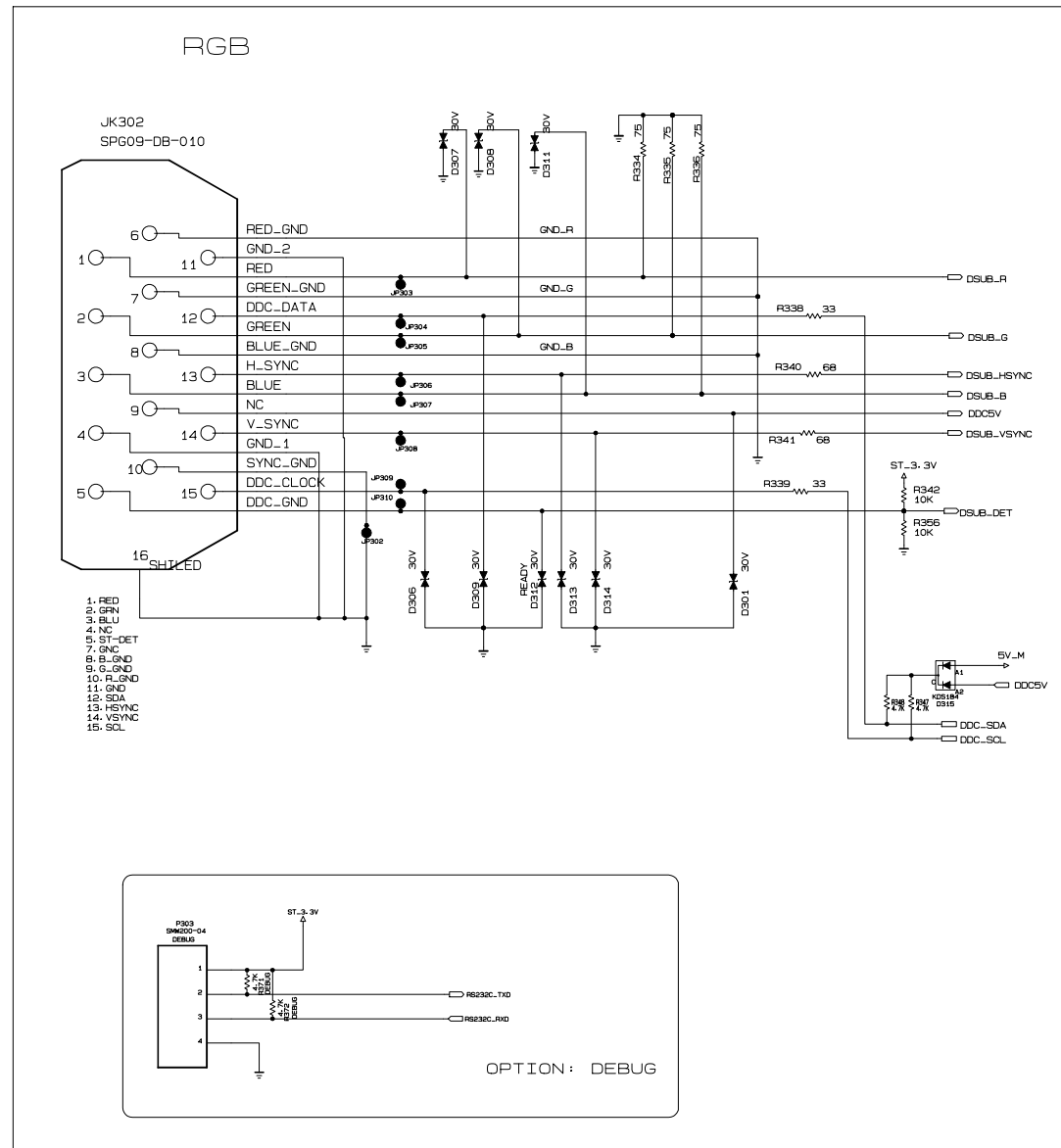
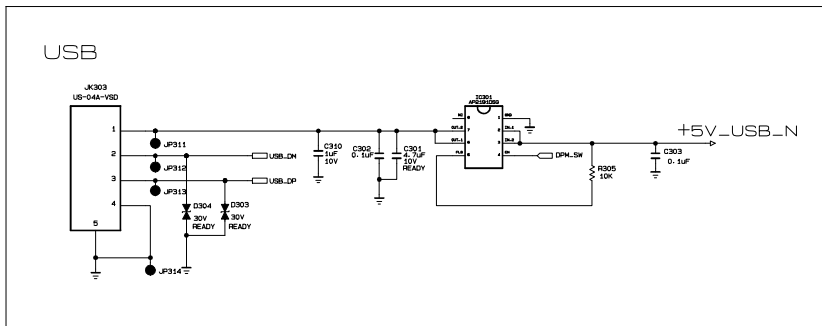
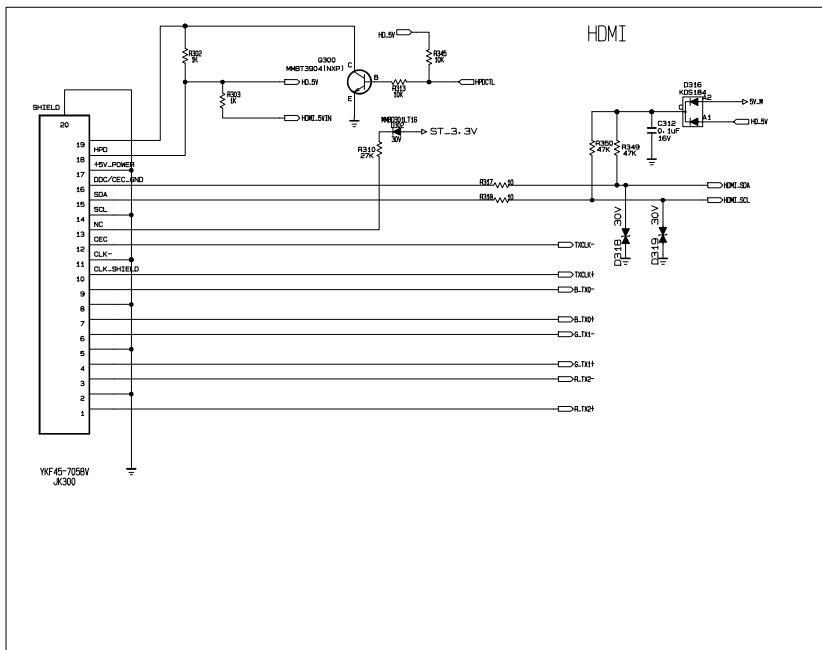

THE SYMBOL MARK OF THIS SCHEMATIC DIAGRAM INCORPORATES SPECIAL FEATURES IMPORTANT FOR PROTECTION FROM X-RADIATION. FILTR AND ELECTRICAL SHOCK HAZARDS. WHEN SERVICING IF IS ESSENTIAL THAT ONLY MANUFACTURES SPECIFIED PARTS BE USED FOR THE CRITICAL COMPONENTS IN THE SYMBOL MARK OF THE SCHEMATIC.

SECRET
LGElectronics



MODEL	EAX64892902_0	DATE	2012/07/17
BLOCK	HDMI/RGB	SHEET	2 / 7

TUNER

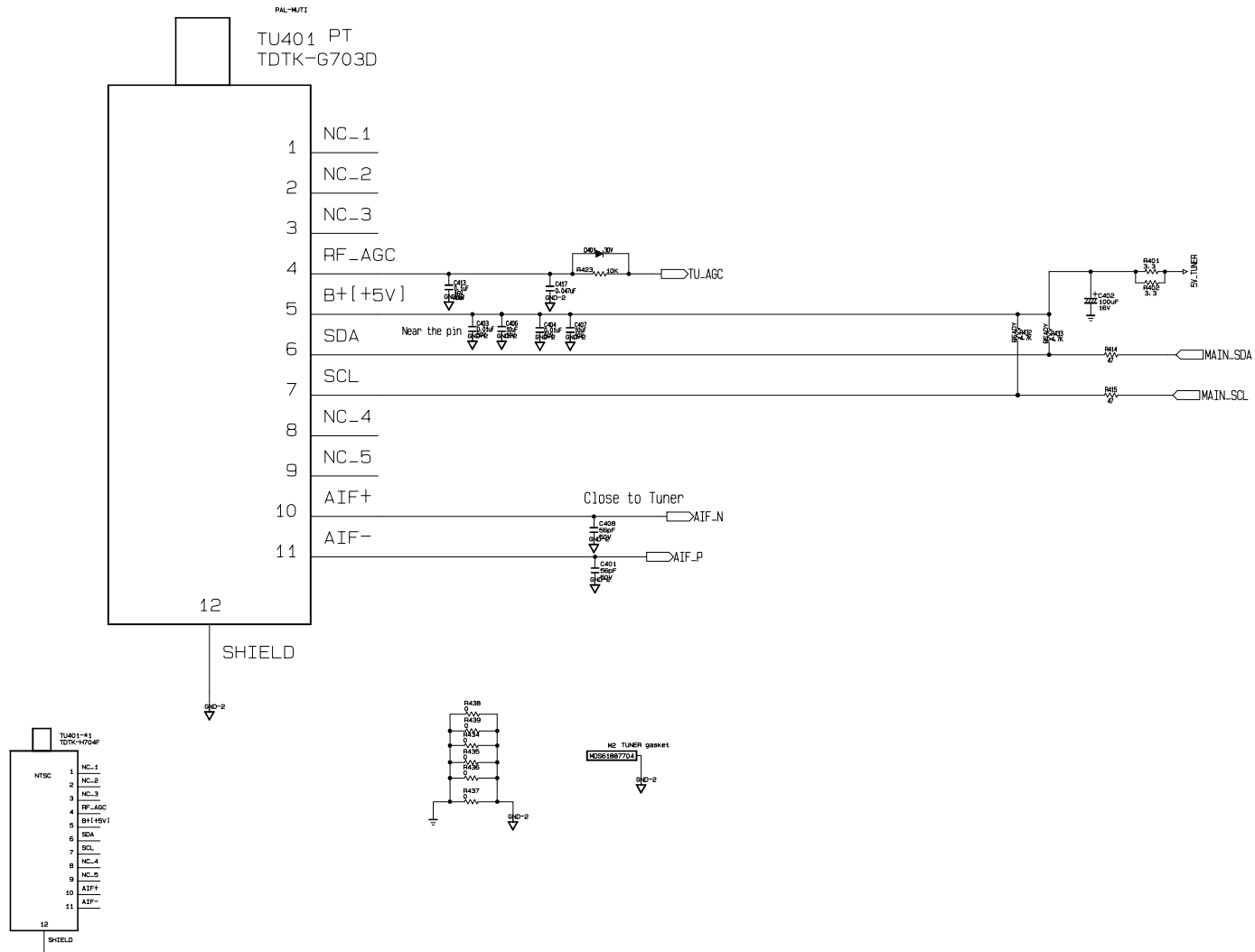

THE SYMBOL MARK OF THIS SCHEMATIC DIAGRAM INCORPORATES SPECIAL FEATURES IMPORTANT FOR PROTECTION FROM X-RADIATION. FILTRE AND ELECTRICAL SHOCK HAZARDS. WHEN SERVICING IF IS ESSENTIAL THAT ONLY MANUFACTURERS SPECIFIED PARTS BE USED FOR THE CRITICAL COMPONENTS IN THE SYMBOL MARK OF THE SCHEMATIC.

SECRET
LGElectronics



MODEL	EAX64892902_0	DATE	2012/07/17
BLOCK	TUNER	SHEET	3/7

AUDIO

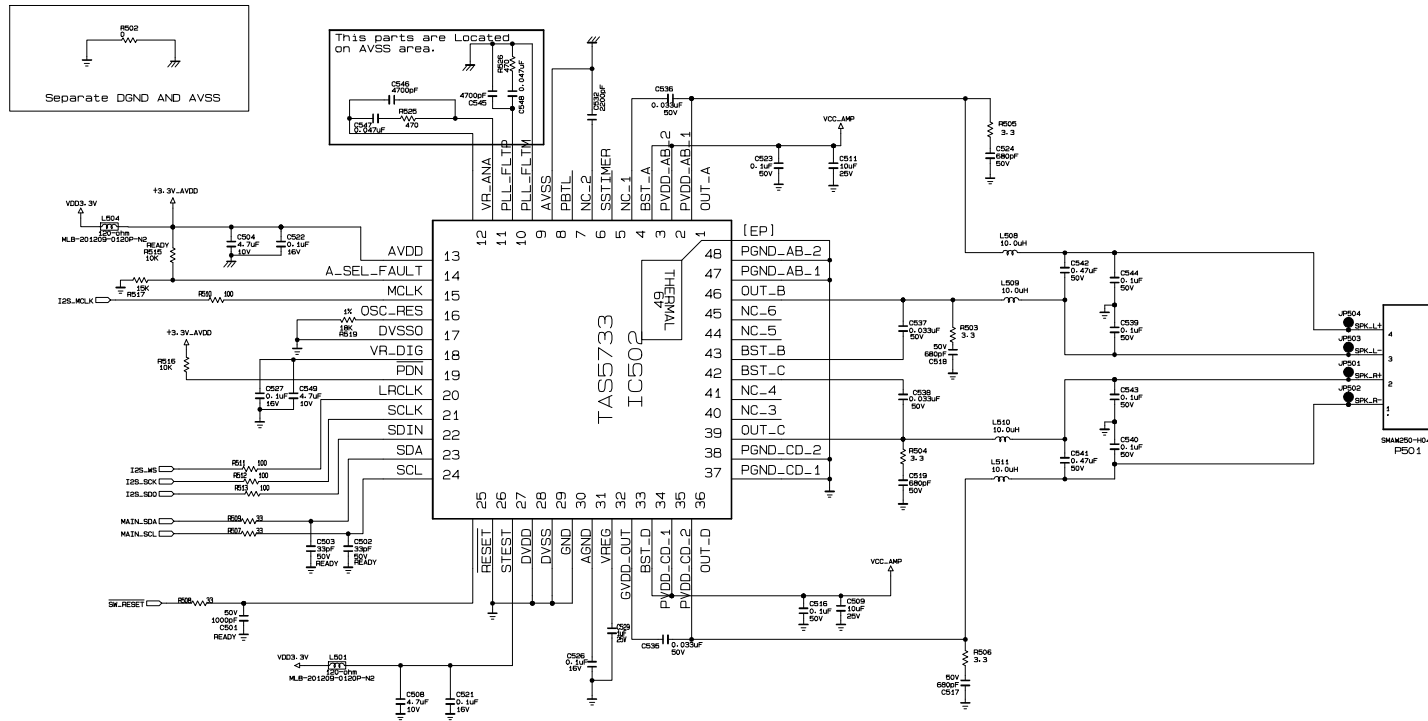

THE SYMBOL MARK OF THIS SCHEMATIC DIAGRAM INCORPORATES SPECIAL FEATURES IMPORTANT FOR PROTECTION FROM X-RADIATION. FILTRE AND ELECTRICAL SHOCK HAZARDS. WHEN SERVICING IF IS ESSENTIAL THAT ONLY MANUFACTURERS SPECIFIED PARTS BE USED FOR THE CRITICAL COMPONENTS IN THE SYMBOL MARK OF THE SCHEMATIC.

SECRET
LGElectronics



MODEL	EAX64892902_0	DATE	2012/07/17
BLOCK	AUDIO	SHEET	4/7

MAIN (MT8223)

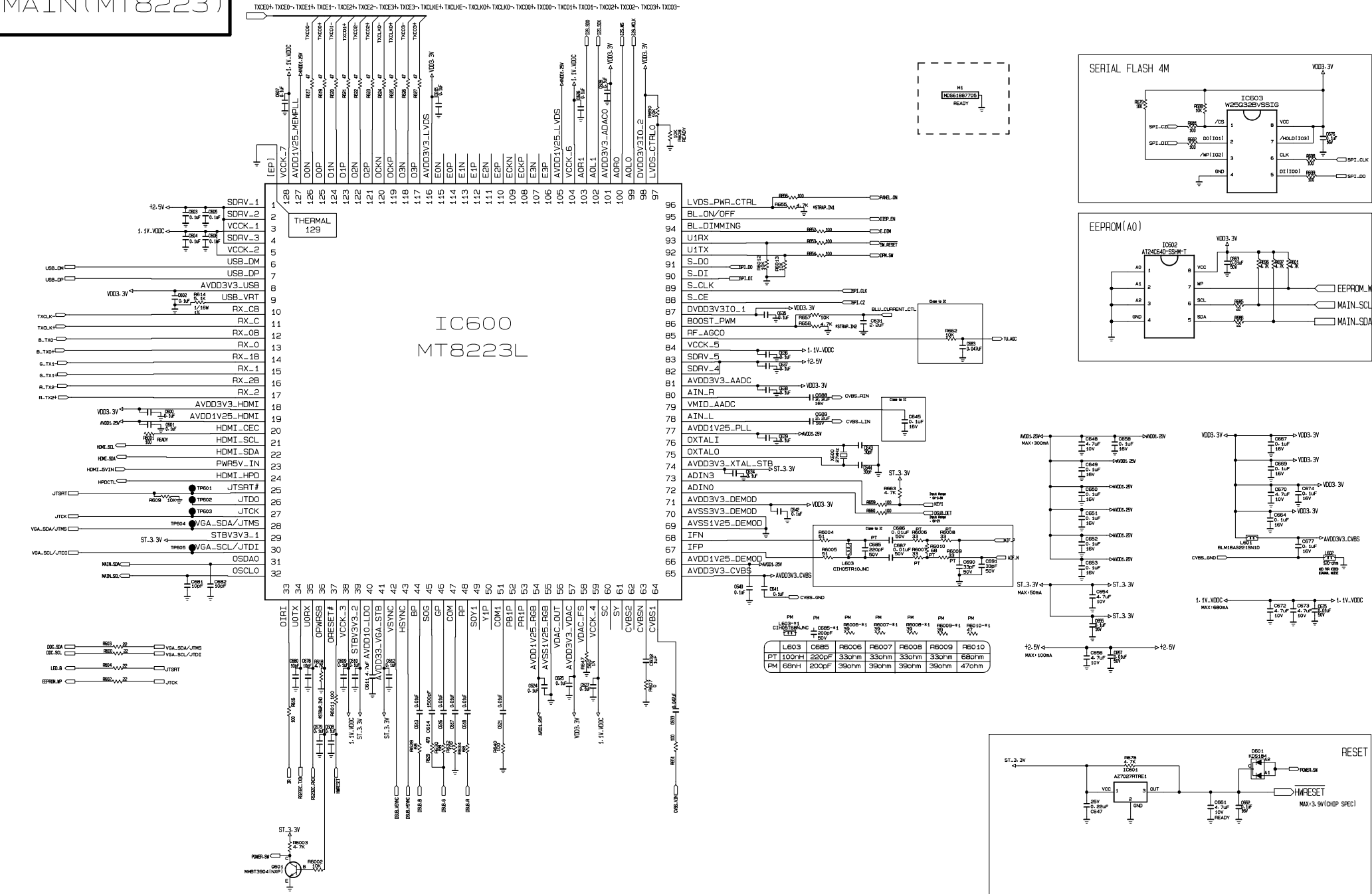

THE Δ SYMBOL MARK OF THIS SCHEMATIC DIAGRAM INCORPORATES SPECIAL FEATURES IMPORTANT FOR PROTECTION FROM X-RADIATION. FILTRE AND ELECTRICAL SHOCK HAZARDS. WHEN SERVICING IF IS ESSENTIAL THAT ONLY MANUFACTURER SPECIFIED PARTS BE USED FOR THE CRITICAL COMPONENTS IN THE Δ SYMBOL MARK OF THE SCHEMATIC.

SECRET
LGElectronics



MODEL	EAX64892902_0	DATE	2012/07/17
BLOCK	MTK8223L	SHEET	5 / 7

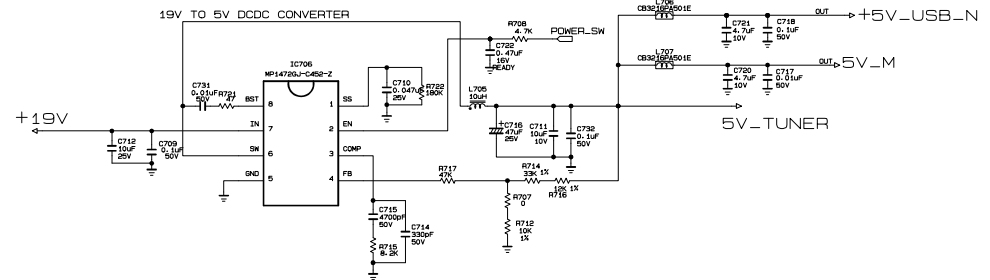
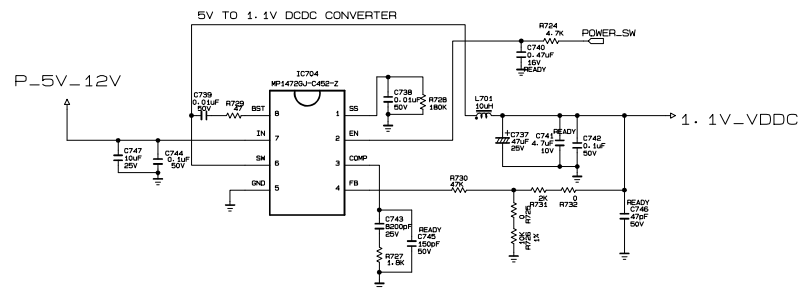
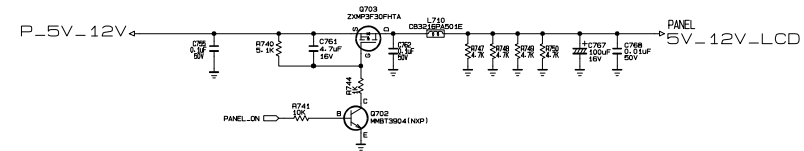
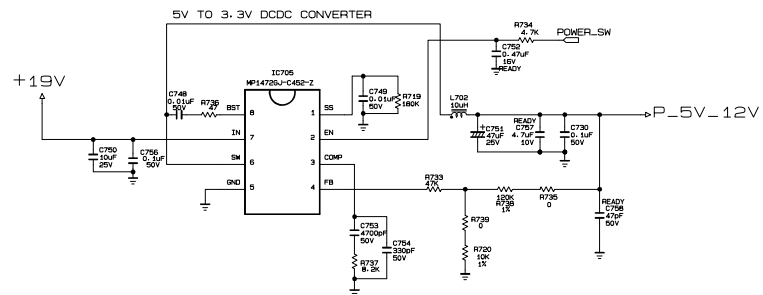
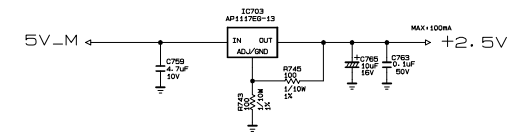
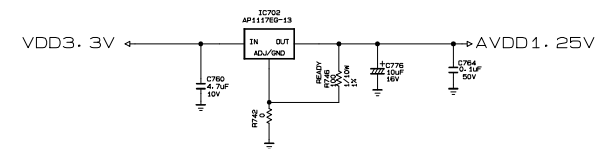
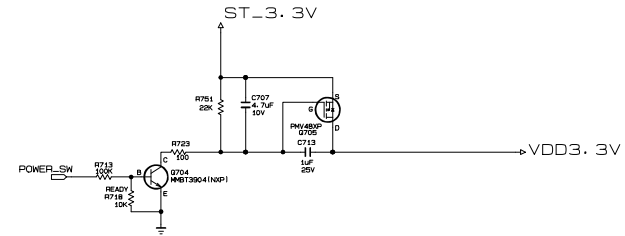
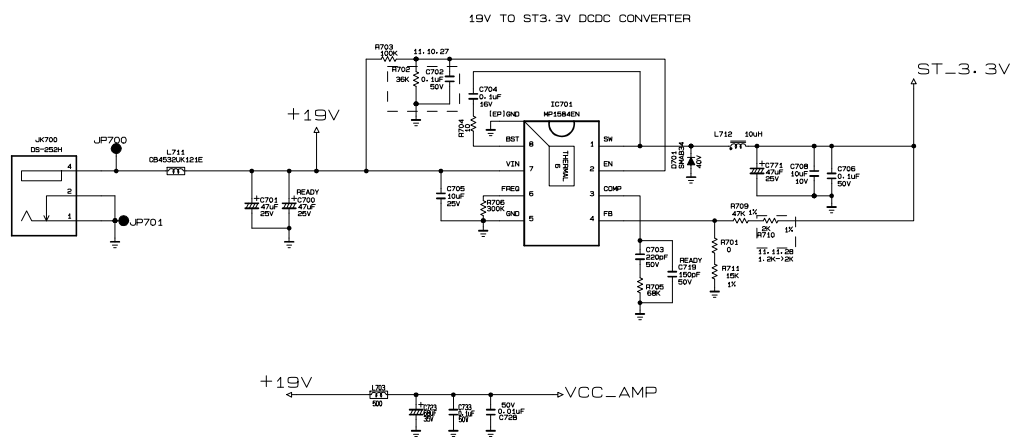

THE Δ SYMBOL MARK OF THIS SCHEMATIC DIAGRAM INCORPORATES SPECIAL FEATURES IMPORTANT FOR PROTECTION FROM X-RADIATION. FILRE AND ELECTRICAL SHOCK HAZARDS. WHEN SERVICING IF IS ESSENTIAL THAT ONLY MANUFACTURES SPECIFIED PARTS BE USED FOR THE CRITICAL COMPONENTS IN THE Δ SYMBOL MARK OF THE SCHEMATIC.

SECRET
LGElectronics

LG ELECTRONICS

MODEL	EAX64892902_0	DATE	2012/07/17
BLOCK	POWER	SHEET	6 / 7

LED_Driver

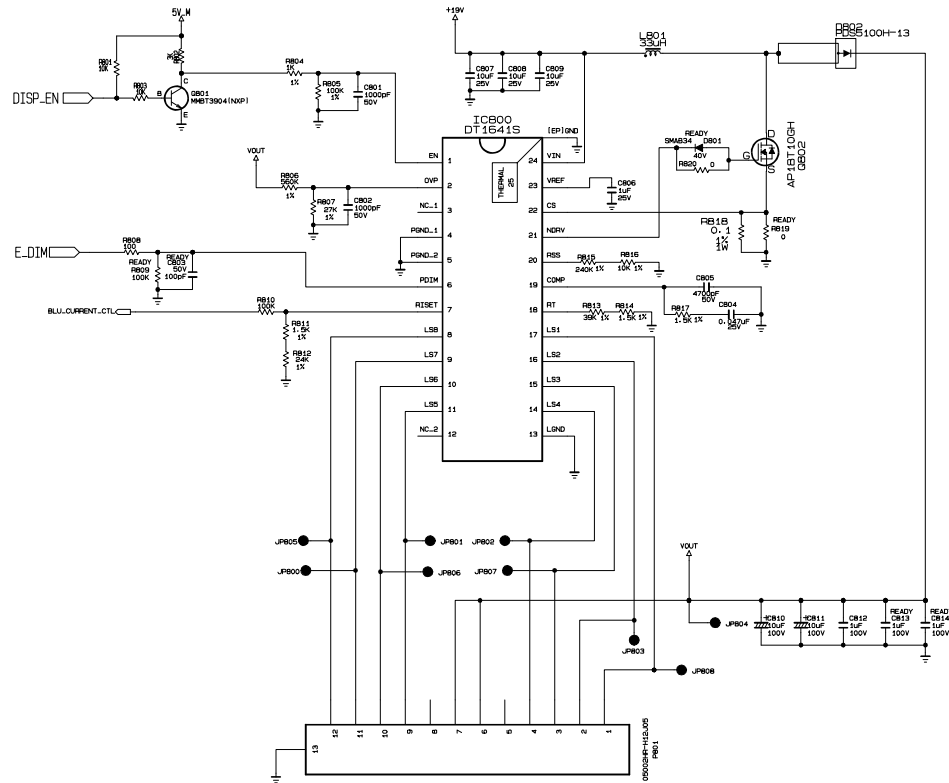

THE SYMBOL MARK OF THIS SCHEMATIC DIAGRAM INCORPORATES SPECIAL FEATURES IMPORTANT FOR PROTECTION FROM X-RADIATION. FILTRE AND ELECTRICAL SHOCK HAZARDS. WHEN SERVICING IF IS ESSENTIAL THAT ONLY MANUFACTURERS SPECIFIED PARTS BE USED FOR THE CRITICAL COMPONENTS IN THE SYMBOL MARK OF THE SCHEMATIC.

SECRET
LGElectronics



MODEL	EAX64892902_0	DATE	2012/07/17
BLOCK	MTK8223L	SHEET	7/7

