

Scanning	LIB.



SPECIFICATION FOR APPROVAL

• **CUSTOMER** : LG Electronics inc.

• **ITEM** : Power Supply Unit.

• **P/NO**

Model Name	Customer	Supplier
LGP4247H-12LPB	EAY62512701	PLDF-L101A

• **DATE** : 2013. 11. 15

• **Revision** : 3.1

• **Remark** : MP (PCB REV 2.0)

Producing District : YANTAI, CHINA (중국 연태)

(생산지)

GWANGJU, KOREA (한국 광주)

BEKASI, INDONESIA (인도네시아 베카시)

WROCLAW, POLAND (폴란드 브루츠와프)

★ **Safety Standard Parts** [안전규격부품 List]

Power Cord, Power Plug, X/Y-Capacitor, Power Switch, Fuse, SMPS Trans, Stand-By Trans, Photo coupler, Insulation(절연) Resistor, Discharge(방전) Resistor, Fusing Resistor, FBT.CPT, CPT Socket, DY, D-Coil, Line Filter, PCB Material, Front / Back-cover Material Relay(1-2차간), Varistor, Adapter

★ **EMC Standard Parts** [전자규격 부품 List]

Power Plug, Line Filter, X-Capacitor, Y-Capacitor, SMPS Trans, Tuner, Saw-Filter, Shield Case, Oscillator, Pattern Change

★ **Green** [유해물질 확인사항]

This item must meet the standards of LG Electronics for six major substances as designated by RoHS for control.

(Cd: 10ppm under, Pb/Hg/Cr+6/PBB/PBDE: 100 ppm under)

	LG Innotek Co., Ltd
	LG Twin Tower 33/34F, Yeouido-dong,
	Yeongdeungpo-gu, Seoul, Korea
	Tel. : +82-2-3777-1114
	Fax. : +82-2-3777-0082

Documentation For Approval

Model Name	Customer	Supplier
LGP4247H-12LPB	EAY62512701	PLDF-L101A

Written	Checked		Approved
J.S Lee	J.Y Kim		S.H JANG

Contents

NO.	A table of contents	Page
1	Documentation of Approval	1~2
2	Contents	3
3	Revision History & Software Revision History	4~8
4	CTQ Management & Model Marking	9
5	Specification 1. INTRODUCTION 2. SPECIFICATION 2.1 Input Requirements 2.2 Power Output Characteristics 2.3 Environment Requirement 2.4 Dielectric Strength Voltage and Insulation Resistance 2.5 Burn-in 2.6 Interface 2.7 Product Safety 2.8 Construction 2.9 Function of protection 2.10 Sound Noise Characteristics. 2.11 Connector Specification 2.12 PCB Dimension. 2.13 Apply to Eyelet point. 2.14 Electrical Characteristics 2.15 Mechanical Characteristics	10~20
6	Schematic Diagram	21~22
7	Block Diagram	23~24
8	Parts List	25~31
9	Process Marking	32~33
10	PCB Layout	34~38
11	Safety Parts	39~42
12	Mechanical Drawing	43~45
13	Packing Drawing	46~51
14	Bar-code Label Drawing	52~53
15	Labeling Point	54~55
16	Workmanship Point	56~57
17	Manufacturing Process (Flow-Chart)	58~61
18	* Appendix A1. Power Check list A2. Warranty letter	62~73

Revision History

Rev No.	Contents	Date of Approval	Checked	Remark															
1.0	<p>Apply to MP (PCB REV 1.0) PCB P/No.EAX64310401(1.4) Micom Ver : 1.00a (Checksum : 0x2214)</p> <p>1. ADD UL Marking.</p>	11.12.14	J.Y Kim																
1.1	<p>Apply to MP (PCB REV 1.0) PCB P/No.EAX64310401(1.4)</p> <p>1. Add Producing District - Add Bekasi, Indonesia - Add WROCLAW, POLAND</p> <p>2. Add Indonesian localized box maker - Add Yumi</p>	12.02.10	K.T.Choi																
1.2	<p>Apply to MP (PCB REV 1.0) PCB P/No.EAX64310401(1.4)</p> <p>1. Check VLED voltage on Aging to figure out MLCC crack - Check if VLED voltage is at least 3V higher than typical value.</p> <table border="1" style="margin-left: 40px;"> <thead> <tr> <th style="text-align: center;">Model</th> <th style="text-align: center;">Typical</th> <th style="text-align: center;">Condition for detecting</th> </tr> </thead> <tbody> <tr> <td style="text-align: center;">4247H</td> <td style="text-align: center;">58.5 V</td> <td style="text-align: center;">higher than 61.5 V</td> </tr> <tr> <td style="text-align: center;">55H</td> <td style="text-align: center;">78 V</td> <td style="text-align: center;">higher than 81 V</td> </tr> <tr> <td style="text-align: center;">4247L</td> <td style="text-align: center;">67.2 V</td> <td style="text-align: center;">higher than 70.2 V</td> </tr> <tr> <td style="text-align: center;">55L</td> <td style="text-align: center;">76.8 V</td> <td style="text-align: center;">higher than 79.8 V</td> </tr> </tbody> </table>	Model	Typical	Condition for detecting	4247H	58.5 V	higher than 61.5 V	55H	78 V	higher than 81 V	4247L	67.2 V	higher than 70.2 V	55L	76.8 V	higher than 79.8 V	12.02.24	K.T.Choi	
Model	Typical	Condition for detecting																	
4247H	58.5 V	higher than 61.5 V																	
55H	78 V	higher than 81 V																	
4247L	67.2 V	higher than 70.2 V																	
55L	76.8 V	higher than 79.8 V																	
1.3	<p>Apply to MP (PCB REV 1.0) PCB P/No.EAX64310401(1.4)</p> <p>1. Reduce the size of Air vinyl - Before : 750L * 270W - After : 585L * 270W</p>	12.04.23	K.T.Choi																

Revision History

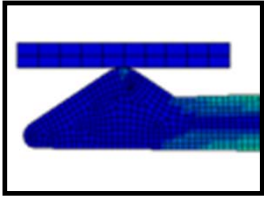
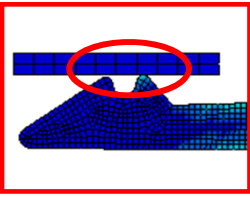
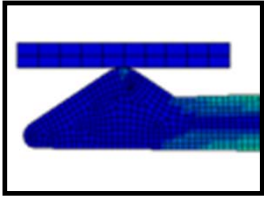
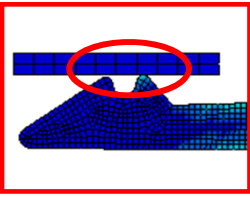
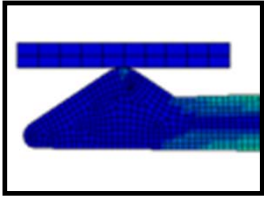
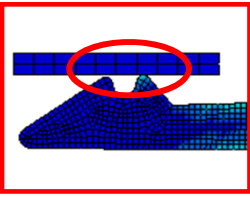
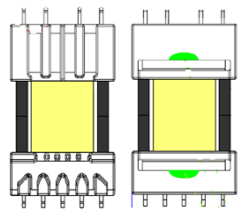
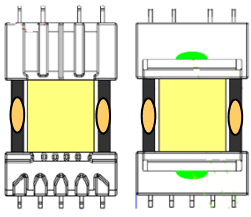
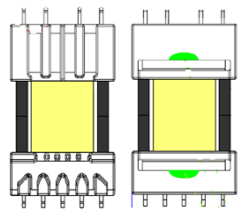
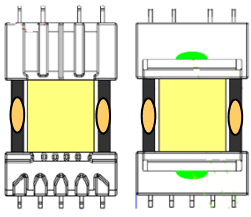
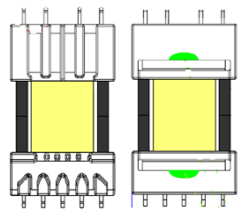
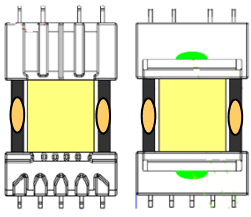
Rev No.	Contents	Date of Approval	Checked	Remark				
1.4	<p>Apply to MP (PCB REV 1.0) PCB P/No.EAX64310401(1.4)</p> <p>1. Change FFC Connector contact point for improving contact N.G. ISSUE.</p> <div style="text-align: center;"> <table border="1" style="width: 100%;"> <tr> <td style="text-align: center;">Before</td> <td style="text-align: center;">After</td> </tr> <tr> <td style="text-align: center;"></td> <td style="text-align: center;"></td> </tr> </table> </div>	Before	After			12.05.11	K.T.Choi	
Before	After							
								
1.5	<p>Apply to MP (PCB REV 1.0) PCB P/No.EAX64310401(1.4)</p> <p>1. Add ST product site. (STF13NM60-Q601,Q602) - Longgang / China : Assy Plant Code – G4 - Change application : PB Free → Halogen Free</p>	12.06.11	K.T.Choi					
1.6	<p>Apply to MP (PCB REV 1.0) PCB P/No.EAX64310401(1.4)</p> <p>1. Change 1uF, 2.2uF MLCC VENDOR. - ONLY USE TDK, MURATA. - APPLY TO 2012. 07. 01.</p>	12. 06.20	K.T.Choi					
1.7	<p>Apply to MP (PCB REV 1.0) PCB P/No.EAX64310401(1.4)</p> <p>1. Apply STBY Trans (12S-LS01) which has additional bonding points to improve noise. - Maker : FEELUX - Location : T501 - Bonding points : Top side of core junction Bottom side of core junction</p> <div style="text-align: center;"> <table border="1" style="width: 100%;"> <tr> <td style="text-align: center;">Before</td> <td style="text-align: center;">After</td> </tr> <tr> <td style="text-align: center;"></td> <td style="text-align: center;"></td> </tr> </table> </div>	Before	After			12. 06.29	K.T.Choi	
Before	After							
								

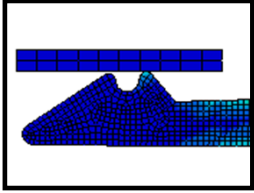
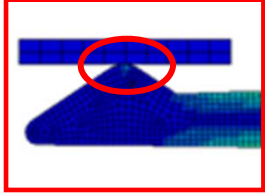
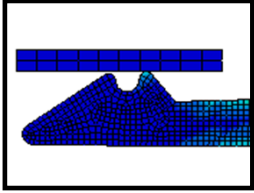
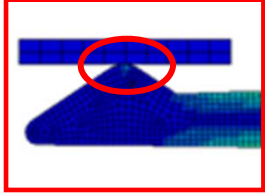
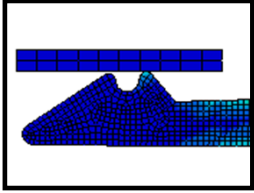
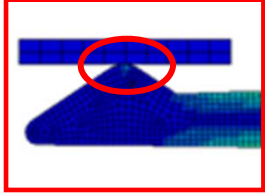
Rev No.	Contents	Date of Approval	Checked	Remark				
1.8	<p>Apply to MP (PCB REV 1.0) PCB P/No.EAX64310401(1.4)</p> <p>1. Change FFC Connector contact point for improving contact N.G. ISSUE.</p> <div data-bbox="296 461 979 743" style="border: 1px solid black; padding: 5px; text-align: center;"> <table border="1" style="width: 100%; border-collapse: collapse;"> <thead> <tr> <th style="width: 50%;">Before</th> <th style="width: 50%;">After</th> </tr> </thead> <tbody> <tr> <td style="text-align: center;"></td> <td style="text-align: center;"></td> </tr> </tbody> </table> </div>	Before	After			12.07.10	K.T.Choi	
Before	After							
								
1.9	<p>Apply to MP (PCB REV 1.0) PCB P/No.EAX64310401(1.4)</p> <p>1. Delete FDT86106LZ from Parts list</p> <ul style="list-style-type: none"> - Name : FDT86106LZ - Maker : FAIRCHILD - Location : Q801, Q802, Q803, Q804, Q805, Q806 Q807, Q808, Q809, Q810, Q811, Q812 	12.08.17	K.T.Choi					
2.0	<p>Apply to MP (PCB REV 1.0) PCB P/No.EAX64310401(1.4)</p> <p>1. Box Change</p> <ul style="list-style-type: none"> - Add : Box Silk (Bar Code and Tape Line) 	12.08.24	K.T.Choi					

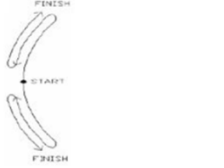
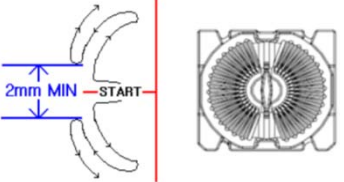
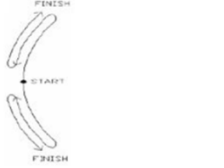
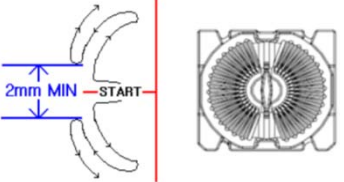
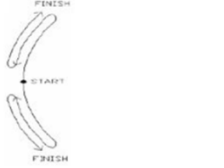
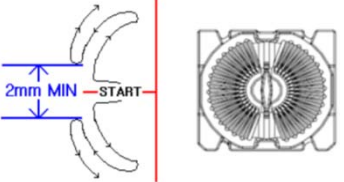
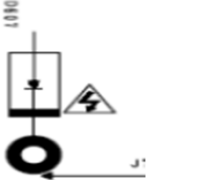
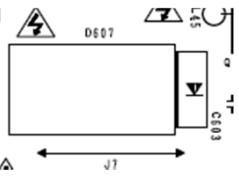
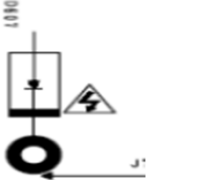
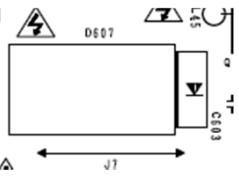
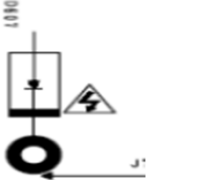
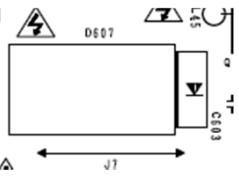
Rev No.	Contents	Date of Approval	Checked	Remark																																																
2.1	<p>Apply to MP (PCB REV 1.0) PCB P/No.EAX64310401(1.4)</p> <p>1. Reinforce Line Filter Spec. - Item : LLF-121, 25mH</p> <p>1) Secure a split winding distance</p> <table border="1" data-bbox="236 577 976 891"> <thead> <tr> <th>Before</th> <th>After</th> </tr> </thead> <tbody> <tr> <td style="text-align: center;">X</td> <td style="text-align: center;">2mm Min</td> </tr> <tr> <td style="text-align: center;">  </td> <td style="text-align: center;">  </td> </tr> </tbody> </table> <p>2) Change Impedance - Before</p> <table border="1" data-bbox="236 1025 992 1115"> <thead> <tr> <th></th> <th>0.15MHz</th> <th>0.45MHz</th> <th>1MHz</th> <th>5MHz</th> <th>10MHz</th> <th>30MHz</th> </tr> </thead> <tbody> <tr> <td>FREQUENCY (MHz)</td> <td>0.15</td> <td>0.45</td> <td>1</td> <td>5</td> <td>10</td> <td>30</td> </tr> <tr> <td>IMPEDANCE (KΩ)</td> <td>20.0</td> <td>20.0</td> <td>8.0</td> <td>0.5</td> <td>0.1</td> <td>0.01</td> </tr> </tbody> </table> <p>- After</p> <table border="1" data-bbox="236 1205 992 1294"> <thead> <tr> <th></th> <th>0.15MHz</th> <th>0.45MHz</th> <th>1MHz</th> <th>5MHz</th> <th>10MHz</th> <th>30MHz</th> </tr> </thead> <tbody> <tr> <td>FREQUENCY (MHz)</td> <td>0.15</td> <td>0.45</td> <td>1</td> <td>5</td> <td>10</td> <td>30</td> </tr> <tr> <td>IMPEDANCE (KΩ)</td> <td>22.0</td> <td>29.0</td> <td>8.0</td> <td>0.5</td> <td>0.1</td> <td>0.1</td> </tr> </tbody> </table>	Before	After	X	2mm Min				0.15MHz	0.45MHz	1MHz	5MHz	10MHz	30MHz	FREQUENCY (MHz)	0.15	0.45	1	5	10	30	IMPEDANCE (KΩ)	20.0	20.0	8.0	0.5	0.1	0.01		0.15MHz	0.45MHz	1MHz	5MHz	10MHz	30MHz	FREQUENCY (MHz)	0.15	0.45	1	5	10	30	IMPEDANCE (KΩ)	22.0	29.0	8.0	0.5	0.1	0.1	12.09.20	K.T.Choi	
Before	After																																																			
X	2mm Min																																																			
																																																				
	0.15MHz	0.45MHz	1MHz	5MHz	10MHz	30MHz																																														
FREQUENCY (MHz)	0.15	0.45	1	5	10	30																																														
IMPEDANCE (KΩ)	20.0	20.0	8.0	0.5	0.1	0.01																																														
	0.15MHz	0.45MHz	1MHz	5MHz	10MHz	30MHz																																														
FREQUENCY (MHz)	0.15	0.45	1	5	10	30																																														
IMPEDANCE (KΩ)	22.0	29.0	8.0	0.5	0.1	0.1																																														
3.0	<p>Apply to MP (PCB REV 2.0) PCB P/No. EAX64310401(1.6)</p> <p>1. Change the type of PFC Output Diode - Location : D607 - Axial type → TO-220 type</p> <table border="1" data-bbox="236 1608 976 1886"> <thead> <tr> <th>Before</th> <th>After</th> </tr> </thead> <tbody> <tr> <td style="text-align: center;">  </td> <td style="text-align: center;">  </td> </tr> </tbody> </table>	Before	After			12.10.18	K.T.Choi																																													
Before	After																																																			
																																																				

Rev No.	Contents	Date of Approval	Checked	Remark
3.1	<p>Apply to MP (PCB REV 2.0) PCB P/No. EAX64310401(1.6)</p> <p>1. L6599AD change assembly site and material</p> <p>As is ; Before Change</p> <ul style="list-style-type: none"> I. Old Assembly site : Amkor in Philippines → "B" marking II. Labels : Assembled in Philippines III. Old Wire : Au <p>To be ; After Change</p> <ul style="list-style-type: none"> I. New Assembly site Shenzhen in China → "K" marking II. Labels : Assembled in China III. New Wire : Copper(Cu) <p>2. 4M Change Process</p> <ul style="list-style-type: none"> 1)Responsibility of 4M Change ; LGE 2)Running Change ; Yes 3)Goods of Stock ; no rework 	13.11.15	K.T.Choi	

Software Revision History

No.	Firmware Revision Contents	Date of Approval	Checked	Remark
1	- Firmware Version 1.00a Checksum 0x2214	11.12.14	J.Y Kim	

CTQ Management

No.	Contents	Page
1	2.1.1 Power Factor	11
2	2.2 Power Output Characteristics	12
3	2.2.1. Stand by Power Consumption	12

Specification

1. INTRODUCTION

1.1 Scope

This approval is the description related to every electrical and structural specifications and reliability For Power Supply Unit used on 42 inch, 47 inch LGE LED TV.

1.2 Customers product related items

Product : Power Supply Unit

Part code : EAY62512701

1.3 Product name

Product name : PLDF-L101A

Revision code : 3.1

2. SPECIFICATION

2.1 Input Requirements

Nominal Input Voltage	AC 100V to AC 240V
Input Voltage Variation	AC 90V to AC 264V
Input Current	Under 2.5Arms . (at 100Vac & Nominal Load) Under 1.3Arms . (at 240Vac & Nominal Load)
Nominal Frequency	50 / 60 Hz
Frequency Variation Range	47 Hz to 63 Hz
Phase	Single
Leakage Current	0.7mA_peak. (100Vac ~ 240Vac)
Surge Immunity	$\pm 4\text{kV} / 1000\text{ns} / 0^\circ$ to 360°
Hold-up Time	More than 20ms at 100Vac and maximum output load
Lightning Surge	2kA Normal, Common Mode
Inrush Current	80A zero-peak max at cold start and any specified line, load, temperature conditions.

2.1.1 Power Factor

over than 0.9 at 90 – 264Vac & max load condition

2.2 Power Output Characteristics

Output	Voltage Variable range [V]	Rated Current (Min, Max) [Amean]	Voltage Regulation [V]	Ripple Voltage [mVp_p]
3.5V (STBY)	3.3V ~ 3.7V	0.3W Under(15mA)	-	-
		1.8A(0~1.8A) (ON condition)	± 5%	250 mVp_p
	12V	11.4V ~ 12.6V	2.0A (0.1~2.0A)	± 5%
24	21.6V ~ 26.4V	1.2A (0.1~1.2A)	± 10%	500 mVp_p
LED B+	45.9V ~ 63.7V	0.105A(0.10185~0.10815A) ×12Ch	-	-

* On Condition : In a moment of Power_ON Signal activated, the current of 3.5V output should be limited within 40mA(Max) at LCD TV condition for stability.

Do not turn "Power_ON" Signal on at the load condition of 3.5V output, more than 40mA.

* Total regulation for each output circuit includes the results of input voltage variation, load variation, warm-up drift and temperature change.

* The following instruments shall be used for measuring ripple noise.

1. Probe having impedance ratio of 1:1.
2. Oscilloscope having frequency characteristic of 100MHz or more.

Test Point : power output each pin

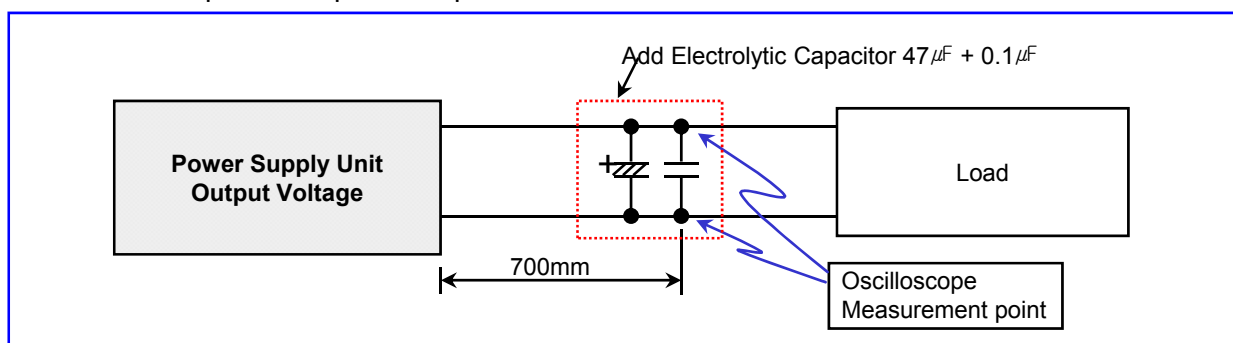

※ Ripple and noise are measured at the end of output cable which are added a 0.1uF ceramic capacitor and 47uF electrolytic capacitor. (connected parallel)

2.2.1 Stand By Power Consumption

Output Voltage	3.5V (STBY)	12V	24V
Load [A]	0.015	Don't Care (Power-Off)	
Wattage [W]	Less than 0.3W Under (230Vac / 50Hz)		

2.3 Environment Requirement

Operating Temperature Range	-10 °C to 40 °C (60 °C :No Hardware Failure, TV SET Condition)
Operating Humidity Range	30 to 85 %
Storage Temperature Range	-25 to 85 deg.
Storage humidity Range	5 to 90 %
MTBF (Mean Time Between Failure)	50,000 hour
Cooling Condition	Natural Air
Shock	98 m/s ² Shock test consists of pivoting the power supply, from one edge of it's bottom side, on a flat surface (such as wood having thickness of 10mm or more) and allowing the opposite edge to fall from a height of 50mm to this surface. The test is performed three times on each edge of the bottom side of the power supply

2.4 Dielectric Strength Voltage and Insulation Resistance



Dielectric Strength Voltage	AC 3KV or DC 4240V 1Min 10mA (Test SPEC) AC 3.6KV 1 SEC 10 mA.(PSU Mass Production) Between Primary and All Secondary Circuits.
Insulation Resistance	Insulation resistance shall be more than 8M ohm (at DC 500V) Between Primary Live, Neutral line and Secondary.

* Above tests are performed at room temperature in non-condensing atmospheric conditions

* Frame grounds are connected to secondary circuits.

2.5 Burn-in

More than 2 hours at 40 °C (±5 °C), Normal input voltage.

AC on/off must be test 1 time after burn-in.

80% Load (except LED String current : 105mA) of specification.

2.6 Interface

Appellation	Explanation	Signal Direction	Action
POWER ON	Vcc Circuit ON/OFF	Input	High : Vcc ON Low : Vcc OFF

2.7 Product Safety



Safety Standards to be applied	Design to meet the requirements as follows UL60950, IEC60950, IEC60065 and 60950
EMI/RFI Standards to be applied	Design to meet the requirements as follows FCC and EN55020, EN55013 Class B with 4dB minimum margin.

2.8 Construction

Weight	Less than 900g
Unit Size (typ.)	243(W) X 245(D) X 18.9(H)

2.9 Function of protection

Protection	Output Circuit	Trip point		Notes
		Min	Max	
Over Current	STBY 3.5V	2.5A	8.0A	Auto Re-start
	12V	5.0A	22.0A	Latch
	24V	2.5A	15.0A	Latch
Short Circuit	STBY 3.5V	-	-	Auto Re-start
	12V	-	-	Latch
	24V	-	-	Latch

- * This Power Supply has above-mentioned protections.
- * Short circuit protection between different output terminals is not considered.
- * Trip point for over voltage indicates the operating point when the output voltage slowly increases.
- * The conditions of Over Current measurement
Multi output(3.5V,12V,24V) is nominal load state except an over current measurement.

2.10 Sound Noise Characteristics.

PSU Noise Specification

22.5 dB(a) / 20. μ Pa 2.0E-5 Pa

(1/1 octave, A-weighting, to 1kHz ~ 16kHz Total overall)

Measure Location : Anechoic Room

Measure Condition : At a distance of 60cm mic

Full white pattern, at AC 110V/220V

The max specification

(measure 3 points, at PSU center and left & right on the side)

PSU NOISE MEASURE POINT

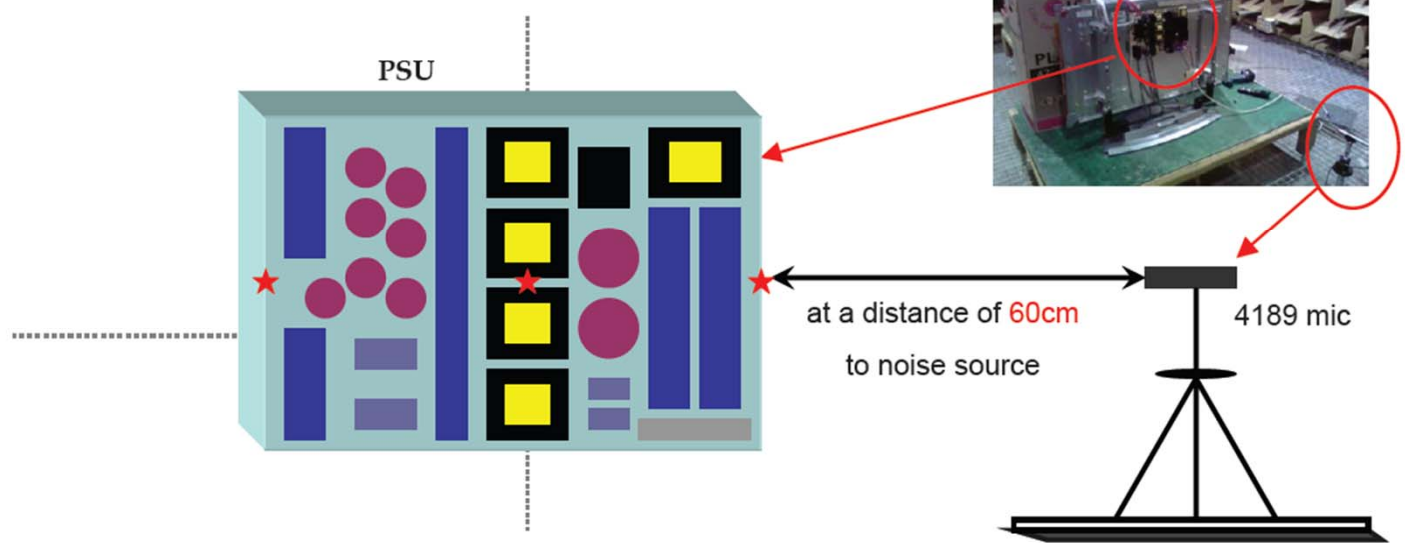

2.11 Connector Specification

2.11.1 Connectors Usage

SK100 (DAC-18D3A) (Black angle type)

No	Name
1	LIVE
2	NEUTRAL

P701 (SMAW200A-H08A2)

No	Name
1	VSYNC_IN
2	I2C_SDA
3	I2C_SCL
4	SIN
5	GND
6	SCLK
7	N.C
8	REVERSE

P702 (20010WR-06A03)

No	Name
1	MICOM_VDD
2	RXD
3	TXD
4	TOOL 0
5	RESET
6	GND

P201 (SMAW200-H24S2)

P201			
1	Power on	2	24V
3	24V	4	24V
5	GND	6	GND
7	GND	8	GND
9	3.5V	10	3.5V
11	3.5V	12	3.5V
13	GND	14	GND
15	GND	16	V-SYNC
17	12V	18	DRV_ON
19	12V	20	N.C
21	12V	22	PWM Dim#1
23	PWM Dim#2	24	Error_out

P202 (IS100-L08T-C46) (BLACK)

No	Name
1	VC_6
2	VC_5
3	VC_4
4	VC_3
5	VC_2
6	VC_1
7	N.C
8	LED +

P203 (IS100-L08T-C46-A) (WHITE)

No	Name
1	LED +
2	N.C
3	VC_12
4	VC_11
5	VC_10
6	VC_9
7	VC_8
8	VC_7

2.12 PCB Dimension.
(CTI - 600)

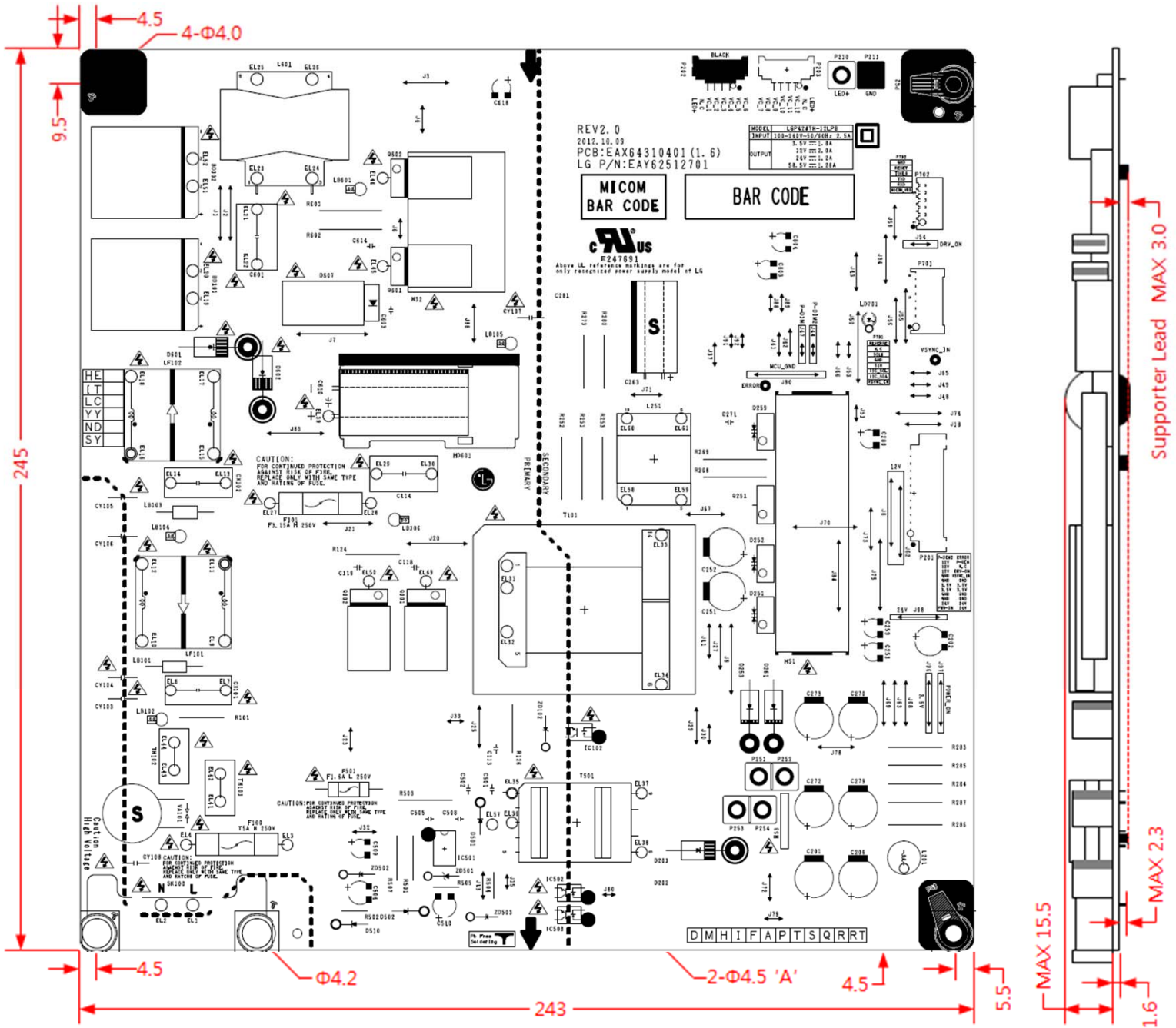

- 1) Power board PCB : 243mm X 245mm X 1.6(T)mm
- 2) Component height ; Max 15.5mm
- 3) Lead Cutting : Max 2.3mm (except HD Max 3.5mm)
- 4) PCB Material : FR-1,KB,DS,L,R-8700 CTI-600

2.13 Apply to the Eyelet point.(LGP4247H-12LPB)

Apply to the Eyelet point 2.0Φ : EL1,EL2,EL9,EL10,EL11,EL12,EL15,EL16,EL17,EL18,EL19,EL20,EL23,EL24,EL25, EL26,EL31,EL32,EL33,EL34,EL51,EL52 (22EA)

Apply to the small Eyelet point 1.6Φ : EL3,EL4,EL7,EL8,EL13,EL14,EL21,EL22,EL27,EL28,EL29,EL30,EL35,EL36, EL37,EL38, EL39,EL41,EL42,EL43,EL44,EL45,EL46,EL49,EL50,EL57,EL58, EL59,EL60,EL61 (30EA)

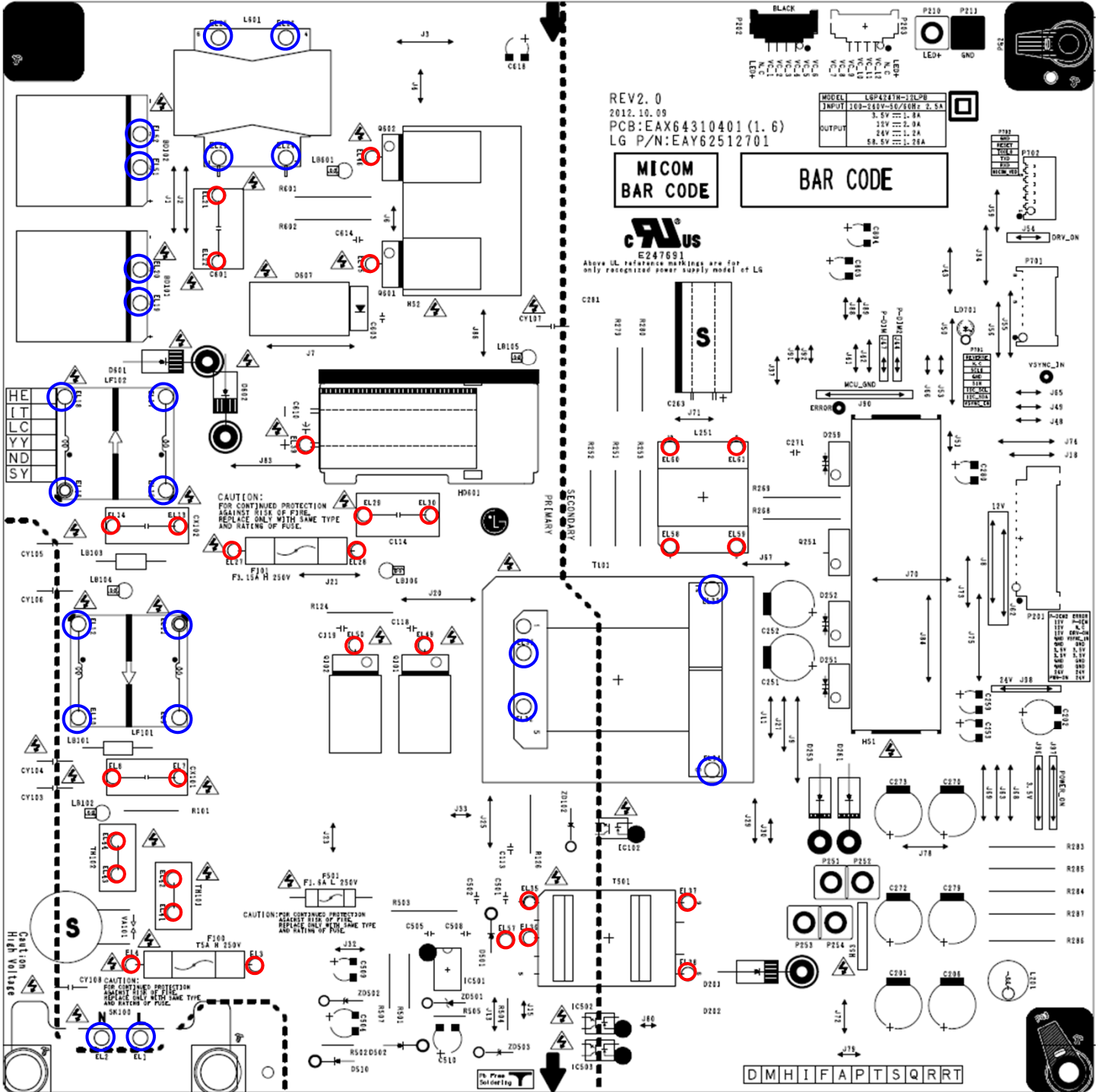

2.14 Electrical Characteristics

No.	Test Item	Test method																		
1	Intermittent Operation stability Test	The switching regulator shall ON/OFF for 20,000 time at an Interval of 10 sec at maximum load, after that electrical Characteristics shall be satisfied.																		
2	Low temperature operation	The switching regulator is left at the operating guarantee Minimum temperature for 2 hours without applying electricity. After that power shall be turned on, and then the electrical Characteristics shall be satisfied.																		
3	Low temperature Storage test Leave At low temperature	The switching regulator is left at minimum storage Temperature for 96 hours or more. Then the switching regulator is left at a room temperature and humidity for 1 hour or more, after that electrical characteristics shall be satisfied.																		
4	Heat cycle storage test	<p>The switching regulator is 10 consecutive temperature cycle that shown below is performed and then leave them at room temperature and humidity for 1 hour or more. After that, electrical characteristics shall be satisfied.</p> <table border="1"> <thead> <tr> <th>Time</th> <th>Temperature</th> </tr> </thead> <tbody> <tr> <td>30 minutes</td> <td>25℃</td> </tr> <tr> <td>30 minutes</td> <td>25℃ -> -20℃</td> </tr> <tr> <td>60 minutes</td> <td>Minimum storage temperature (-20℃)</td> </tr> <tr> <td>30 minutes</td> <td>-20℃ -> 25℃</td> </tr> <tr> <td>30 minutes</td> <td>25℃</td> </tr> <tr> <td>30 minutes</td> <td>25℃ -> 70℃</td> </tr> <tr> <td>60 minutes</td> <td>Maximum storage temperature (70℃)</td> </tr> <tr> <td>30 minutes</td> <td>70℃ -> 25℃</td> </tr> </tbody> </table>	Time	Temperature	30 minutes	25℃	30 minutes	25℃ -> -20℃	60 minutes	Minimum storage temperature (-20℃)	30 minutes	-20℃ -> 25℃	30 minutes	25℃	30 minutes	25℃ -> 70℃	60 minutes	Maximum storage temperature (70℃)	30 minutes	70℃ -> 25℃
Time	Temperature																			
30 minutes	25℃																			
30 minutes	25℃ -> -20℃																			
60 minutes	Minimum storage temperature (-20℃)																			
30 minutes	-20℃ -> 25℃																			
30 minutes	25℃																			
30 minutes	25℃ -> 70℃																			
60 minutes	Maximum storage temperature (70℃)																			
30 minutes	70℃ -> 25℃																			
5	Heat shock test	<p>Heat shock test performed under following conditions without applying electricity and then leave them at room temperature and humidity for 1 hour or more. After that, electrical characteristics shall be satisfied.</p> <p>Condition : -45℃(30minutes), 120℃(30minutes), Switching time : Less than 5 minutes, 200 cycles.</p>																		

2.15 Mechanical Characteristics

No.	Test Item	Test method
1	Appearance	<p>There shall be no contaminant or dirt on the switching regulator which has adverse effect on electrical characteristics.</p> <p>There shall be no excessive unevenness or scratches on the plated or painted surface.</p>
2	Vibration	<p>While applying electricity :</p> <p>Vibration frequency : 5 ~ 100Hz</p> <p>Acceleration : 4.9 m/s ²</p> <p>Vibration in X,Y,Z direction for 30 minutes</p> <p>While applying electricity :</p> <p>Vibration frequency : 5 ~ 100Hz</p> <p>Acceleration : 14.7 m/s ²</p> <p>Vibration in X,Y,Z direction for 30 minutes</p> <p>After that electrical characteristics shall be satisfied.</p> <p>There shall be no damage to appearance and construction.</p>
3	Shock	<p>Shock : 98 m/s ²</p> <p>On the oak more than 10mm thickness with the flat face, raise the one side for 50mm, and it carries out each side free fall for three sides.</p> <p>There shall be no damage to appearance and construction.</p>

Schematic Diagram

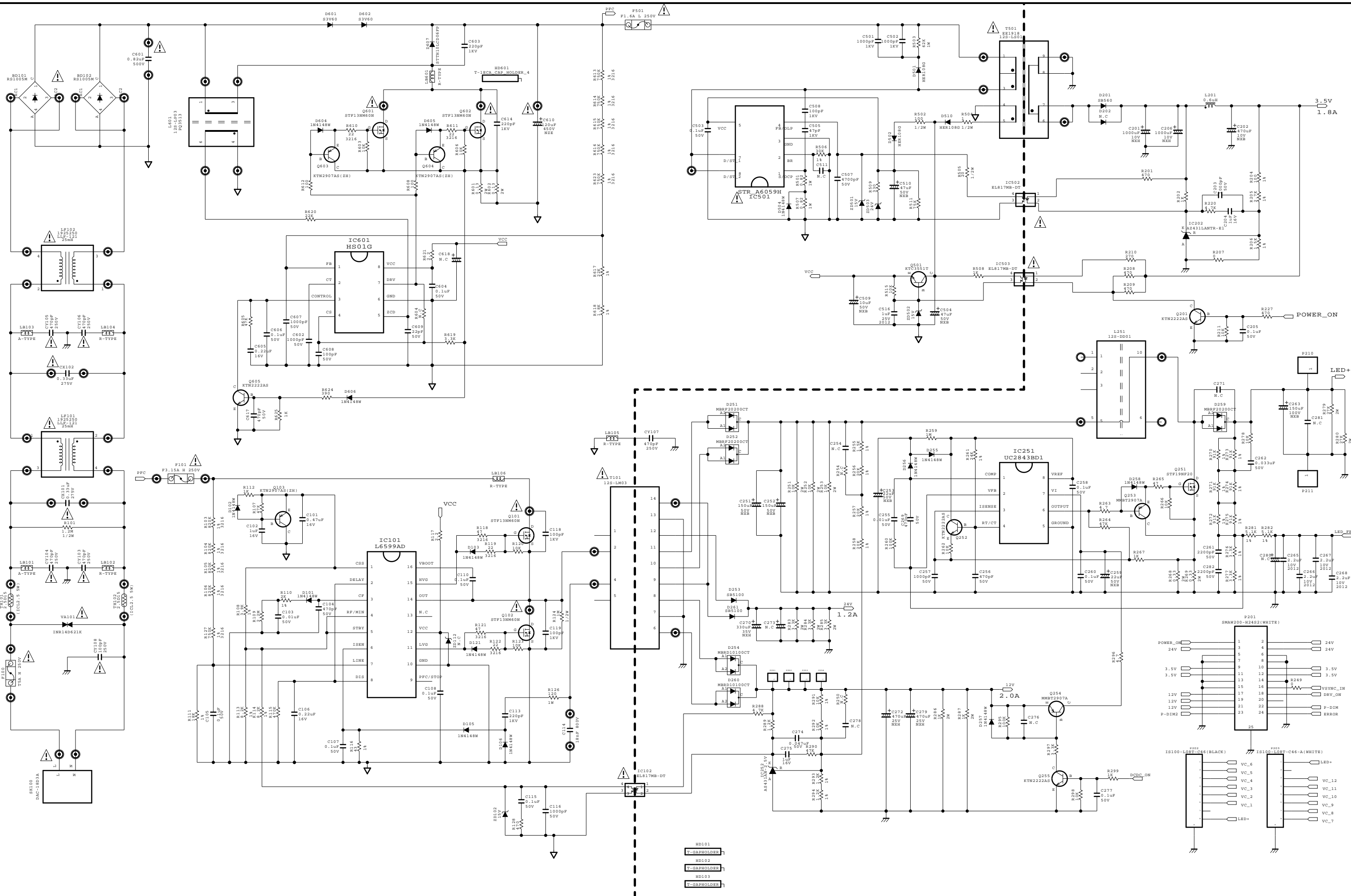

THE SYMBOL MARK OF THIS SCHEMATIC DIAGRAM INCORPORATES SPECIAL FEATURES IMPORTANT FOR PROTECTION FROM X-RADIATION. FILRE AND ELECTRICAL SHOCK HAZARDS, WHEN SERVICING IF IS ESSENTIAL THAT ONLY MANUFACTURES SPECIFIED PARTS BE USED FOR THE CRITICAL COMPONENTS IN THE SYMBOL MARK OF THE SCHEMATIC.

SECRET
LGElectronics



MODEL	LGP4247H-12LPB	DATE	'12.10.09
BLOCK	PFC\STBY\MULTI	SHEET	1 / 2

REV 2.0

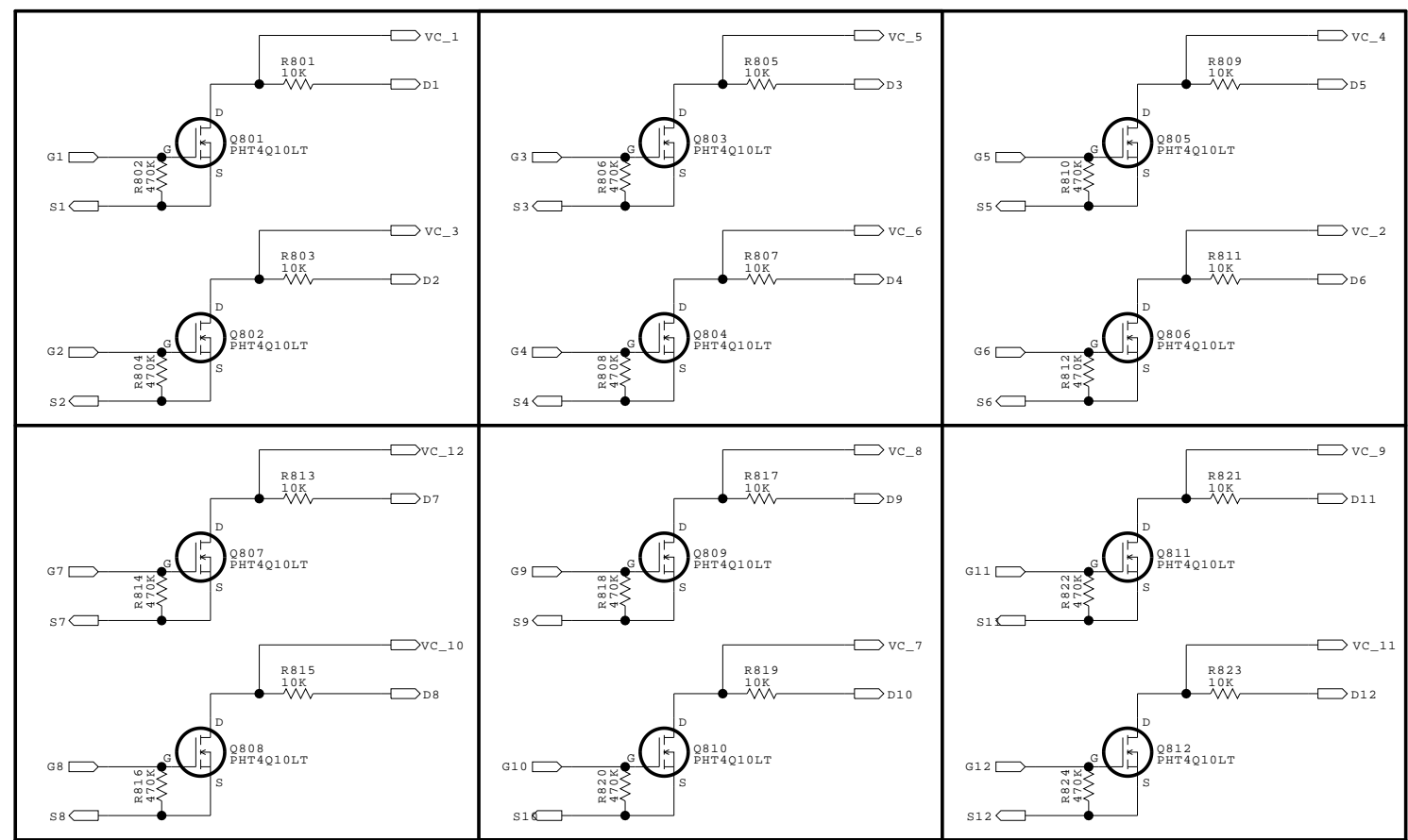
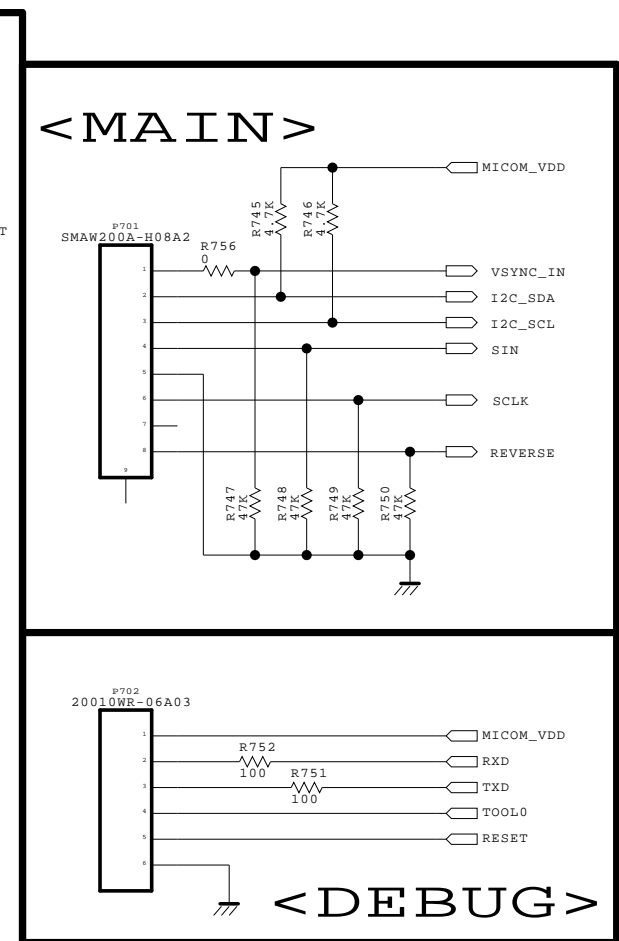
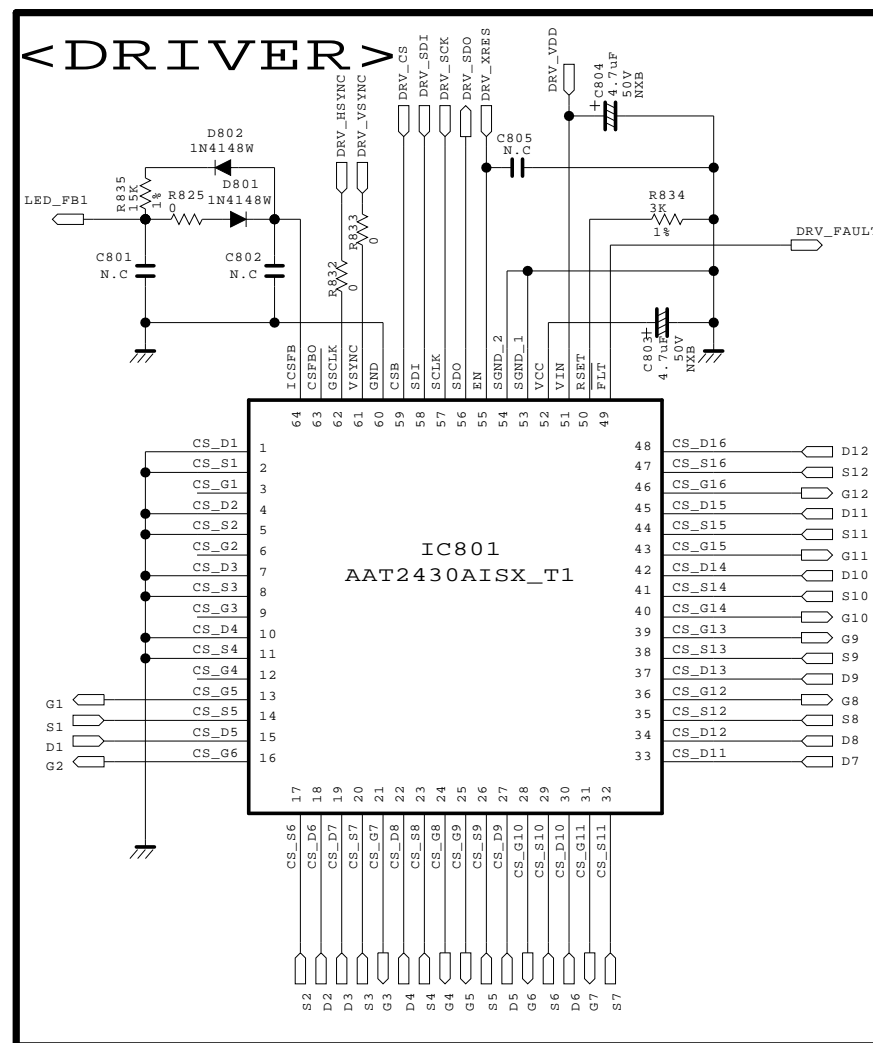
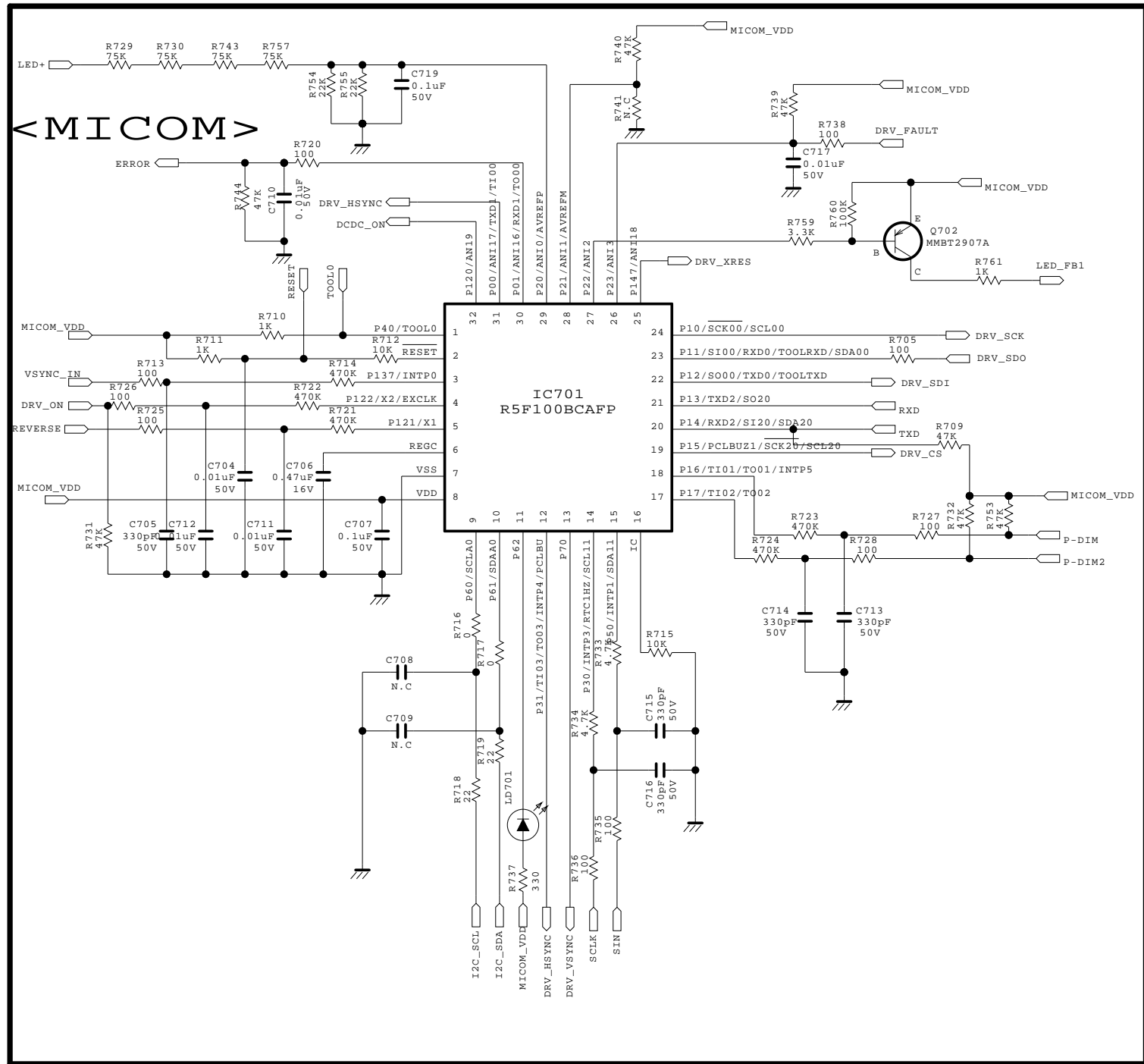
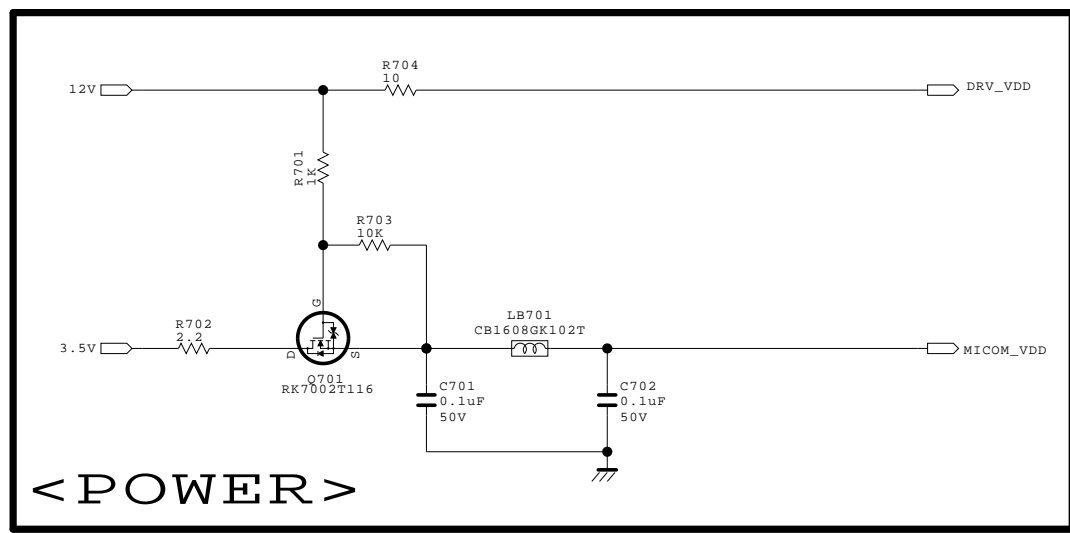

THE SYMBOL MARK OF THIS SCHEMATIC DIAGRAM INCORPORATES SPECIAL FEATURES IMPORTANT FOR PROTECTION FROM X-RADIATION. FILRE AND ELECTRICAL SHOCK HAZARDS, WHEN SERVICING IF IS ESSENTIAL THAT ONLY MANUFACTURES SPECIFIED PARTS BE USED FOR THE CRITICAL COMPONENTS IN THE SYMBOL MARK OF THE SCHEMATIC.

SECRET
LGElectronics



MODEL
BLOCK

LGP4247H-12LPB
DRV

DATE
SHEET

REV 2.0
'12.10.09
2 / 2

Block Diagram

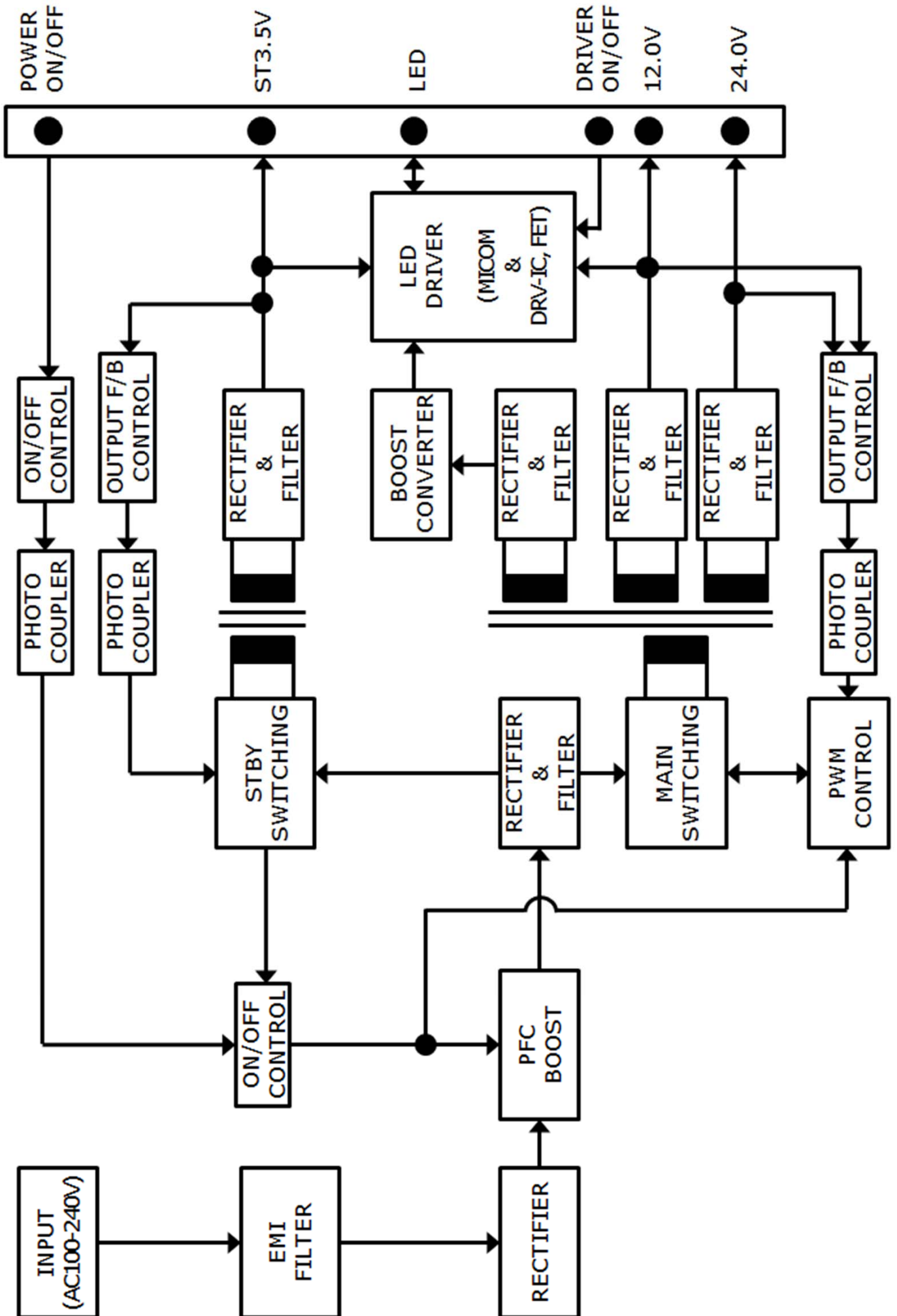

Parts List

No	Level	Q'ty	Unit	Location	Specification	Description	Maker
1	MI	1	EA	HS1	MULTI DIODE ASS'Y	HEAT SINK ASS'Y	
2	MI	1	EA	HS1	LPB4247_55 HS1 (20 X 70 X 8mm)	HEAT SINK	CHENG CHIA MINGXUE Y AOFENG BAOCHENG INNO D&C YUWON NRT HUA GUANG HUA PENG GUOTAI Onsung Pampas
3	MI	3	EA	D251,D252,D259	MBRF20200CT 20A 200V TO-220FP MBRF20U200CT 20A 200V TO-220FP	DIODE	SENSITRON KEC
4	MI	1	EA	Q251	STF19NF20 200V 15A TO-220FP TK15A20D 200V 15A TO-220FP	FET	STM TOSHIBA
5	MI	4	EA	FOR D251,D252,D259,Q251	M/S S/W + Φ3.0 7L SILVER PLATE HEAD	SCREW	JUNGWOO SEOUL METAL ASIA BOLT SUNG HO METAL KUOFBI HUIYU MACHINERY DELIKANG DONG HAIKANG RUI YOU TANJIN METAL
6	MI	1	GR	FOR D251,D252,D259,Q251	HC300 OKC-5500 G746 YG6111 DS-323 AK100 AK100 KD-3	SILICON GREASE	CHANG AMLS OKONG SHINETSU MOMENTIVE DONGYANG SILICON SUNNICO TAIZBOND SHIN WEI
7	MI	1	EA	HS2	PFC FET ASS'Y	HEAT SINK ASS'Y	
8	MI	1	EA	HS2	LPB4247_55 HS2 (25 X 38 X 5.5mm)	HEAT SINK	CHENG CHIA MINGXUE Y AOFENG BAOCHENG INNO D&C YUWON NRT HUA GUANG HUA PENG GUOTAI Onsung Pampas
9	MI	2	EA	Q601,Q602	IPA60R280E6 650V 13.8A TO-220FP STF13NM60N 650V 11A TO-220FP	FET	INFINEON STM
10	MI	2	EA	FOR Q601,Q602	M/S S/W + Φ3.0 7L SILVER PLATE HEAD	SCREW	JUNGWOO SEOUL METAL ASIA BOLT SUNG HO METAL KUOFBI HUIYU MACHINERY DELIKANG DONG HAIKANG RUI YOU TANJIN METAL
11	MI	0.5	GR	FOR Q601,Q602	HC300 OKC-5500 G746 YG6111 DS-323 AK100 AK100 KD-3	SILICON GREASE	CHANG AMLS OKONG SHINETSU MOMENTIVE DONGYANG SILICON SUNNICO TAIZBOND SHIN WEI
12	MI	1	EA		LGP4247H-12LPB MI & AI COMPONENTS	MI & AI ASS'Y	
13	MI	2	EA	BD101,BD102	RS1005M 600V 10A L-FORMING KBJ1006G 600V 10A L-FORMING D10XB60 600V 10A L-FORMING	BRIDGE-DIODE	RECTRON LITE-ON DACHANG
14	MI	1	EA	C263	NXB 150uF 100V MRB P5 Φ12.5x25 MF 150uF 100V MRB P5 Φ13x25	CAPACITOR, ALUMINIUM	SAMYOUNG SUSCON
15	MI	1	EA	C610	NZE 120uF 450V MP7.5 Φ18x40 SK120uF 450V MP7.5 Φ18x40	CAPACITOR, ALUMINIUM	SAMYOUNG SUSCON
16	MI	1	EA	C601	MPHB 0.82uF 500V J P15 MP 0.82uF 500V J P15 PCMP 372/472 0.82uF 500V J P15	CAPACITOR,FILM	EUROPTRONIC LUMEN PILKOR
17	MI	1	EA	C114	MPLB 0.018uF 1000V J P15 NP 0.018uF 800V J P15 PCMP 384 0.018uF 800V J P15	CAPACITOR,FILM	EUROPTRONIC LUMEN PILKOR
18	MI	2	EA	CX101,CX102	PCX2 337 0.33uF 275V K P15 MPX 0.33uF 275V K P15 CTX 0.33uF 275V K P15	CAPACITOR,FILM	PILKOR EUROPTRONIC CHENG TUNG
19	MI	2	EA	D601,D602	1N5408G 1KV 3A P20 S3V60 600V 3.5A P20 30PDA60 600V 3A P20	DIODE	TSC SHINDENGEN NI
20	MI	1	EA	D607	STTH10LCD06 600V 10A TO-220FP BYV29FX-600 600V 9A TO-220FP	DIODE	STM NXP
21	MI	2	EA	D253,D261	SB5100 100V 5A P20 SR510-24 100V 5A P20 SB5100 100V 5A P20	DIODE	SENSITRON TSC LITE-ON

22	MI	1	EA	D201	SB560 60V 5A P20 SR560 60V 5A P20 SB560 60V 5A P20	DIODE	SENSITRON DACHANG LITE-ON
23	MI	2	EA	Q101,Q102	TK12A60D 600V 12A TO-220FP STF13NM60N 650V 11A TO-220FP	FET	TOSHIBA STM
24	MI	1	EA	F101	F3.15A H 250V 50CF VIOLET (2 LINE) F3.15A H 250V 216 VIOLET (2 LINE)	FUSE, FAST ACTING	DAIN LITTEL FUSE
25	MI	1	EA	F100	T5A H 250V 215 RED(1-LINE) T5A H 250V 50CT RED(1-LINE) T5A H 250V TSC RED(1-LINE)	FUSE, TIME LAG	LITTEL FUSE DAIN WALTER
26	MI	2	EA	PG2,PG3	JS-12-75-04 SPCC 0.4T GND PIN	GND REINFORCE	SAMSUNG JS ST TELECOM PINGOOD DIHUA HUAKANG KANG YA LUNG
27	MI	3	EA	IC102,IC502,IC503	EL817M(DT) B LTV817M-BN	IC	EVERLIGHT LITE-ON
28	MI	1	EA	IC501	STR-A6059H DIP-8	IC	SANKEN
29	MI	2	EA	TH101,TH102	ICL-5W 2R50MSMT DSC2.5D15 2.5Ω 8A Φ15 MF72-2.5D15 2.5Ω 7A Φ15 WTR15D2R5 2.5Ω 8A Φ15	ICL THERMISTOR THERMISTOR THERMISTOR	SMART DSC NSE WMEC
30	MI	1	EA	L201	0.6uH Φ3X10L BAR	INDUCTOR, COIL	DONGYANG TELECOM SOOJUNG CLOVER FEELUX LIENCHANG
31	MI	1	EA	L251	12S-DD01	INDUCTOR, COIL	SOOJUNG JIANGSU CHANNELON ELECTRONIC GROUP FEELUX DONGYANG TELECOM BUJEON LIENCHANG
32	MI	2	EA	LF101,LF102	CS920250S 25mH LH9B020250 25mH LLF-121 25mH LLF-121 25mH	LINE FILTER	TNC DONG IL DONGYANG TELECOM FEELUX
33	MI	1	EA	HD601	EC40.0CAP-F-12	MAIN CAP HOLDER	TBI
34	MI	1	EA	T101	12S-LM03	TRANSFORMER	TDK SOCJUNG JIANGSU CHANNELON ELECTRONIC GROUP DONGYANG TELECOM BUJEON LIENCHANG FEELUX LGIT
35	MI	1	EA	L601	12S-LP03	TRANSFORMER	TDK SOCJUNG JIANGSU CHANNELON ELECTRONIC GROUP DONGYANG TELECOM BUJEON LIENCHANG FEELUX LGIT
36	MI	1	EA	T501	12S-LS01	TRANSFORMER	TDK SOCJUNG JIANGSU CHANNELON ELECTRONIC GROUP DONGYANG TELECOM BUJEON LIENCHANG FEELUX CLOVER
37	MI	1	EA	VA101	INR14D621K-CAP 620V Φ14 L-FORMING TUBE SVC621D-14A TM7 620V Φ14 L-FORMING TUBE WMR14D621 620V Φ14 L-FORMING TUBE	VARIATOR	AMOTECH SAMWHA WMEC
38	MI	1	EA	P702	20010WR-06A03 6PIN WHITE	WAFER	YEONHO
39	MI	1	EA	SK100	DAC-18D3A BLACK	WAFER	DONG IL
40	MI	1	EA	P202	IS100-L08T-C46 8PIN BLACK	WAFER	UJU ELE
41	MI	1	EA	P203	IS100-L08T-C46-A 8PIN WHITE	WAFER	UJU ELE
42	MI	1	EA	P701	SMAW200A-H08A2 8PIN WHITE	WAFER	YEONHO
43	MI	1	EA	P201	SMAW200-H24S2 24PIN WHITE	WAFER	YEONHO
44	SMT	1	EA		LGP4247H-12LPB SMT COMPONENTS		
45	SMT	1	EA	LB701	CB1608GK102T JCBH160808A102	BEAD	SAMWHA JOINSET
46	SMT	1	EA	C609	22pF 50V J 1608 COG	CAPACITOR, CHIP	MURATA PILKOR SAMWHA TAY OY UDEN TDK YAGEO HEC
47	SMT	1	EA	C608	100pF 50V J 1608 COG	CAPACITOR, CHIP	
48	SMT	5	EA	C705,C713,C714,C715,C716	330pF 50V J 1608 COG	CAPACITOR, CHIP	
49	SMT	4	EA	C104,C256,C269,C617	470pF 50V J 1608 COG	CAPACITOR, CHIP	
50	SMT	5	EA	C116,C203,C257,C602,C607	0.001uF 50V K 1608 X7R	CAPACITOR, CHIP	
51	SMT	2	EA	C261,C282	0.0022uF 50V K 1608 X7R	CAPACITOR, CHIP	
52	SMT	1	EA	C507	0.0047uF 50V K 1608 X7R	CAPACITOR, CHIP	
53	SMT	7	EA	C103,C255,C704,C710,C711,C712,C717	0.01uF 50V K 1608 X7R	CAPACITOR, CHIP	
54	SMT	1	EA	C262	0.033uF 50V K 1608 X7R	CAPACITOR, CHIP	
55	SMT	1	EA	C274	0.047uF 50V K 1608 X7R	CAPACITOR, CHIP	
56	SMT	16	EA	C105,C107,C108,C110,C115,C205, C258,C260,C277,C503,C604,C606, C701,C702,C707,C719	0.1uF 50V K 1608 X7R	CAPACITOR, CHIP	

57	SMT	2	EA	C106,C605	0.22uF 16V K 1608 X7R	CAPACITOR, CHIP	MURATA PLKOR SAMWHA TAYOYUDEN TDK YAGEO HEC
58	SMT	2	EA	C101,C706	0.47uF 16V K 1608 X7R	CAPACITOR, CHIP	
59	SMT	3	EA	C102,C204,C275	1uF 16V K 1608 X7R	CAPACITOR, CHIP	
60	SMT	1	EA	C516	1uF 25V K 2012 X7R or 1uF 50V K 2012 X7R(PLKOR 삭제)	CAPACITOR, CHIP	
61	SMT	4	EA	C265,C266,C267,C268	2.2uF 10V K 2012 X7R or 2.2uF 16V K 2012 X7R	CAPACITOR, CHIP	
62	SMT	16	EA	D101,D102,D103,D105,D106,D121, D255,D256,D257,D258,D504,D604, D605,D606,D801,D802	1N4148W 100V 150mA SOD-123 1N4148W 100V 150mA SOD-123 MMSD4148T1 100V 200mA SOD-123 SDS4148G 100V 150mA SOD-123	DIODE	RECTRON DIODES ONSEMI AUK
63	SMT	2	EA	D254,D260	MBRD10100CT 10A 100V D-PACK MBRD10U100CT 10A 100V D-PACK SPEN-210A 10A 100V D-PACK	DIODE	SENSITRON KEC SANKEN
64	SMT	12	EA	Q801,Q802,Q803,Q804,Q805, Q806,Q807,Q808,Q809,Q810, Q811,Q812	PHT4NQ10LT 100V 3.5A SOT-223 MDHT4N20Y 200V 0.85A SOT-223	FET	NXP MAGNACHIP
65	SMT	1	EA	IC101	L6599AD SO-16N	IC	STM
66	SMT	1	EA	IC202	SJ432BS 1.24V ±0.5% SOT-23 TLV431BSN1T1G, 1.24V±0.5%, SOT-23 AZ431LANTR-E1, 1.24V±0.5%, SOT-23	IC	AUK ON SEMI BCD
67	SMT	1	EA	IC251	UC2843B SO-8 AP3843CM SO-8 UC2843B SO-8	IC	ONSEMI BCD STM
68	SMT	1	EA	IC252	SNF431BS 2.5V ±0.5% SOT-23 AS431AN, 2.5V±0.5%, SOT-23 KA431SLMF2, 2.5V±0.5%, SOT-23	IC	AUK BCD FAIRCHILD
69	SMT	1	EA	IC601	SCY99102-HS01G SOIC-8	IC	ONSEMI
70	SMT	1	EA	IC701	R5F100BCAFP	IC	Renesas
71	SMT	1	EA	IC801	AAT2430AISX_T1	IC	AATI
72	SMT	10	EA	J26,J36,J40,J46,J52, J77,J81,J82,J93,J95	0Ω J 3216	RESISTOR, CHIP	KAMAYA PLKOR ROHM SAMSUNG YAGEO TZAIYUAN
73	SMT	4	EA	R119,R122,R610,R611	22Ω J 3216	RESISTOR, CHIP	
74	SMT	2	EA	R118,R121	47Ω J 3216	RESISTOR, CHIP	
75	SMT	6	EA	R127,R613,R614,R615,R616,R623	750KΩ F 3216	RESISTOR, CHIP	
76	SMT	4	EA	R103,R104,R105,R106	820KΩ F 3216	RESISTOR, CHIP	
77	SMT	8	EA	R207,R249,R716,R717,R756, R825,R832,R833	0Ω J 1608	RESISTOR, CHIP	
78	SMT	1	EA	R289	1.2KΩ J 1608	RESISTOR, CHIP	
79	SMT	3	EA	R260,R295,R760	100KΩ J 1608	RESISTOR, CHIP	
80	SMT	14	EA	R608,R612,R705,R713,R720,R725, R726,R727,R728,R735,R736,R738, R751,R752	100Ω J 1608	RESISTOR, CHIP	
81	SMT	25	EA	R120,R123,R211,R262,R266, R278,R298,R515,R603,R606, R703,R712,R715,R801,R803, R805,R807,R809,R811,R813, R815,R817,R819,R821,R823	10KΩ J 1608	RESISTOR, CHIP	
82	SMT	1	EA	R704	10Ω J 1608	RESISTOR, CHIP	
83	SMT	10	EA	R112,R202,R267,R299,R508, R625,R701,R710,R711,R761	1KΩ J 1608	RESISTOR, CHIP	
84	SMT	1	EA	R259	1MΩ J 1608	RESISTOR, CHIP	
85	SMT	1	EA	R109	2.2MΩ J 1608	RESISTOR, CHIP	
86	SMT	3	EA	R117,R621,R702	2.2Ω J 1608	RESISTOR, CHIP	
87	SMT	2	EA	R718,R719	22Ω J 1608	RESISTOR, CHIP	
88	SMT	3	EA	R620,R754,R755	22KΩ J 1608	RESISTOR, CHIP	
89	SMT	1	EA	R210	270Ω J 1608	RESISTOR, CHIP	
90	SMT	3	EA	R297,R619,R759	3.3KΩ J 1608	RESISTOR, CHIP	
91	SMT	1	EA	R108	3.9KΩ F 1608	RESISTOR, CHIP	
92	SMT	2	EA	R509,R737	330Ω J 1608	RESISTOR, CHIP	
93	SMT	1	EA	R624	390Ω J 1608	RESISTOR, CHIP	
94	SMT	6	EA	R220,R288,R733,R734,R745,R746	4.7KΩ J 1608	RESISTOR, CHIP	
95	SMT	2	EA	R263,R296	4.7Ω J 1608	RESISTOR, CHIP	
96	SMT	18	EA	R115,R714,R721,R722,R723,R724, R802,R804,R806,R808,R810,R812, R814,R816,R818,R820,R822,R824	470KΩ J 1608	RESISTOR, CHIP	
97	SMT	5	EA	R128,R201,R208,R209,R227	470Ω J 1608	RESISTOR, CHIP	
98	SMT	15	EA	R107,R264,R290,R605,R709, R731,R732,R739,R740,R744, R747,R748,R749,R750,R753	47KΩ J 1608	RESISTOR, CHIP	
99	SMT	1	EA	R265	47Ω J 1608	RESISTOR, CHIP	
100	SMT	5	EA	R511,R729,R730,R743,R757	75KΩ J 1608	RESISTOR, CHIP	
101	SMT	2	EA	R293,R294	1.2KΩ F 1608	RESISTOR, CHIP	
102	SMT	2	EA	R206,R255	1.5KΩ F 1608	RESISTOR, CHIP	
103	SMT	1	EA	R618	1.8KΩ F 1608	RESISTOR, CHIP	
104	SMT	1	EA	R204	100Ω F 1608	RESISTOR, CHIP	
105	SMT	2	EA	R291,R292	10KΩ F 1608	RESISTOR, CHIP	
106	SMT	1	EA	R835	15KΩ F 1608	RESISTOR, CHIP	
107	SMT	1	EA	R111	18KΩ F 1608	RESISTOR, CHIP	
108	SMT	1	EA	R205	2.7KΩ F 1608	RESISTOR, CHIP	
109	SMT	3	EA	R256,R257,R258	20KΩ F 1608	RESISTOR, CHIP	
110	SMT	1	EA	R617	22KΩ F 1608	RESISTOR, CHIP	
111	SMT	1	EA	R261	24KΩ F 1608	RESISTOR, CHIP	
112	SMT	1	EA	R110	2KΩ F 1608	RESISTOR, CHIP	
113	SMT	2	EA	R276,R277	3.3KΩ F 1608	RESISTOR, CHIP	
114	SMT	1	EA	R506	30KΩ F 1608	RESISTOR, CHIP	
115	SMT	1	EA	R834	3KΩ F 1608	RESISTOR, CHIP	
116	SMT	1	EA	R116	43Ω F 1608	RESISTOR, CHIP	
117	SMT	2	EA	R281,R282	5.1KΩ F 1608	RESISTOR, CHIP	
118	SMT	2	EA	R113,R114	8.2KΩ F 1608	RESISTOR, CHIP	
119	SMT	6	EA	R270,R271,R272,R273,R274,R275	91KΩ F 1608	RESISTOR, CHIP	
120	SMT	3	EA	HD101,HD102,HD103	3X2.45X2.5H	SUPPORTER	POWER VALLEY

121	SMT	1	EA	Q701	2N7002K 60V 300mA SOT-23 2N7002K 60V 380mA SOT-23 RK7002 60V 115mA SOT-23 SSM3K7002F 60V 200mA SOT-23	TRANSISTOR	DIODES ONSEMI ROHM TOSHIBA
122	SMT	1	EA	Q501	KTC3551T 80V 1A TSM NPN BCW66GLT1 45V 800mA SOT-23 NPN 2SC5865 SOT-23 NPN	TRANSISTOR	KEC ONSEMI ROHM
123	SMT	4	EA	Q201,Q252,Q255,Q605	MMBT2222A 40V 600mA SOT-23 NPN KTN2222AS 40V 600mA SOT-23 NPN PMBT2222A 40V 600mA SOT-23 NPN SBT2222A 40V 600mA SOT-23 NPN	TRANSISTOR	ONSEMI KEC NXP AUK
124	SMT	6	EA	Q103,Q253,Q254,Q603,Q604,Q702	MMBT2907A -60V -600mA SOT-23 PNP KTN2907AS -60V -600mA SOT-23 PNP PMBT2907 -60V -600mA SOT-23 PNP SBT2907A -60V -600mA SOT-23 PNP	TRANSISTOR	ONSEMI KEC NXP AUK
125	SMT	0.5	GR		HT-130A-106 HT-130D-7 LOCTITE 3609 NE8800T	BOND (SMD)	HITECH KOREA HITECH KOREA LOCTITE FUJI
126	AI	1	EA		LGP4247H-12LPB AI COMPONENTS		
127	AI	1	EA	C509	NXB 10uF 50V M P5 Φ5X11 SG 10uF 50V M P5 Φ5X11	CAPACITOR, ALUMINUM	SAMYOUNG SUSCON
128	AI	2	EA	C251,C252	NXB 150uF 50V M P5 Φ10X12.5 SG 150uF 50V M P5 Φ10X13	CAPACITOR, ALUMINUM	SAMYOUNG SUSCON
129	AI	2	EA	C253,C259	NXB 22uF 50V M P5 Φ5X11 SG 22uF 50V M P5 Φ5X11	CAPACITOR, ALUMINUM	SAMYOUNG SUSCON
130	AI	2	EA	C803,C804	NXB 4.7uF 50V M P5 Φ5X11 SG 4.7uF 50V M P5 Φ5X11	CAPACITOR, ALUMINUM	SAMYOUNG SUSCON
131	AI	1	EA	C202	NXB 470uF 10V M P5 Φ8X11.5 SG 470uF 10V M P5 Φ8X12	CAPACITOR, ALUMINUM	SAMYOUNG SUSCON
132	AI	2	EA	C504,C510	NXB 47uF 50V M P5 Φ6.3X11 SG 47uF 50V M P5 Φ6.3X11	CAPACITOR, ALUMINUM	SAMYOUNG SUSCON
133	AI	2	EA	C201,C206	NXH 1000uF 10V M P5 Φ10X12.5 MG 1000uF 10V M P5 Φ10X13	CAPACITOR, ALUMINUM	SAMYOUNG SUSCON
134	AI	1	EA	C270	NXH 330uF 35V M P5 Φ10X12.5 MG 330uF 35V M P5 Φ10X13	CAPACITOR, ALUMINUM	SAMYOUNG SUSCON
135	AI	2	EA	C272,C279	NXH 470uF 25V M P5 Φ10X12.5 MG 470uF 25V M P5 Φ10X13	CAPACITOR, ALUMINUM	SAMYOUNG SUSCON
136	AI	3	EA	C113,C603,C614	DG 220pF 1KV K P5 125℃ CK 220pF 1KV K P5 125℃ CT81 220pF 1KV K P5 125℃ CK45 220pF 1KV K P5 125℃	CAPACITOR, CERAMIC	APEX INTEC DONGIL ELEC. YINANDON TDK
137	AI	3	EA	C118,C119,C508	DG 100pF 1KV K P5 125℃ CK 100pF 1KV K P5 125℃ CT81 100pF 1KV K P5 125℃ CK45 100pF 1KV K P5 125℃	CAPACITOR, CERAMIC	APEX INTEC DONGIL ELEC. YINANDON TDK
138	AI	1	EA	C505	DG 47pF 1KV K P5 125℃ CC 47pF 1KV K P5 125℃ CC81 47pF 1KV K P5 125℃ CC45 47pF 1KV K P5 125℃	CAPACITOR, CERAMIC	APEX INTEC DONGIL ELEC. YINANDON TDK
139	AI	2	EA	C501,C502	DG 1000pF 1KV K P5 125℃ CK 1000pF 1KV K P5 125℃ CT81 1000pF 1KV K P5 125℃ CK45 1000pF 1KV K P5 125℃	CAPACITOR, CERAMIC	APEX INTEC DONGIL ELEC. YINANDON TDK
140	AI	5	EA	CY103,CY104,CY105,CY106,CY107	DA 470pF 400V K P10 105℃ DA 470pF 400V K P10 105℃ CT81 470pF 400V K P10 105℃ CD 470pF 400V K P10 105℃	CAPACITOR, CERAMIC	APEX INTEC DONGIL ELEC. YINANDON TDK
141	AI	1	EA	CY108	DA 100pF 400V K P10 105℃ DA 100pF 400V K P10 105℃ CT81 100pF 400V K P10 105℃ CD 100pF 400V K P10 105℃	CAPACITOR, CERAMIC	APEX INTEC DONGIL ELEC. YINANDON TDK
142	AI	3	EA	D501,D502,D510	UF1007 1KV 1A DO-41 UF4007 1KV 1A DO-41 HER108G 1KV 1A DO-41 UF4007 1KV 1A DO-41	DIODE	DIODES DACHANG RECTRON TSC
143	AI	3	EA	ZD102,ZD501,ZD502	1N5245B 15V DO-35 1N5245B 15V DO-35 MTZJ15B 15V DO-34	DIODE, ZENER	VISHAY RECTRON ROHM
144	AI	1	EA	ZD503	1N5252B 24V DO-35 1N5252B 24V DO-35 MTZJ24B 24V DO-34	DIODE, ZENER	VISHAY RECTRON ROHM
145	AI	30	EA	EL3,EL4,EL7,EL8,EL13,EL14,EL21, EL22,EL27,EL28,EL29,EL30,EL35, EL36,EL37,EL38,EL39,EL41,EL42, EL43,EL44,EL45,EL46,EL49,EL50 EL57,EL58,EL59,EL60,EL61	1.6X3.0	EYELET	SAMSUNG JS DOSUNG DAERIN HUAKANG DELKANG SEJIN LEZHI Avico
146	AI	22	EA	EL1,EL2,EL9,EL10,EL11, EL12,EL15,EL16,EL17,EL18, EL19,EL20,EL23,EL24,EL25, EL26,EL31,EL32,EL33,EL34, EL51,EL52	2.0X3.0	EYELET	SAMSUNG JS DOSUNG DAERIN HUAKANG DELKANG SEJIN LEZHI Avico
147	AI	1	EA	F501	F1.6A L 250V 876	FUSE, FAST ACTING	LITTELFUSE

148	AI	6	EA	P210,P211,P251,P252,P253,P254	SSJS236-6-3 (6mm Under)	GT PIN	SAMSUNG JS DOSUNG DAERIN HUA KANG DEL KANG SEJIN LEZHI Avico
149	AI	2	EA	LB101, LB103	BFS3550A0L SINGLE AXIAL SEB3550050BA SINGLE AXIAL	INDUCTOR, BEAD FILTER LEAD	SAMWHA SCC
150	AI	5	EA	LB102, LB104, LB105, LB106, LB601	BFS3550R2F SINGLE RADIAL SER3550050BA SINGLE RADIAL	INDUCTOR, BEAD FILTER LEAD	SAMWHA SCC
151	AI	64	EA	J1, J2, J3, J4, J6, J7, J8, J9, J11, J13, J15, J18, J20, J21, J23, J25, J27, J29, J30, J32, J33, J34, J37, J41, J42, J43, J44, J47, J48, J49, J50, J51, J53, J54, J55, J56, J59, J62, J63, J65, J66, J67, J68, J69, J70, J71, J72, J73, J74, J75, J78, J79, J80, J83, J84, J86, J88, J89, J90, J91, J92, J96, J97, J98	Φ0.6	JUMPER WIRE	DIELEC DAPcsLPcsD TPI TZAI YUAN UNI-OHM ILKWANG DM Seungw on RLC
152	AI	1	EA	LD701	LTL-1CHY-001A, 5mm Pitch Type (Yellow) 204-10UYC-S530, 5mm Pitch Type (Yellow)	LED	LITE-ON EVERLIGHT
153	AI	1	EA	R502	CRS 100Ω 1/2W J SMALL RDM92 100Ω 1/2W J SMALL SFR25H 100Ω 1/2W J SMALL CF 100Ω 1/2W J SMALL	RESISTOR, CARBON FILM	ABCO SMART PLKOR TZAI YUAN
154	AI	1	EA	R504	CRS 1Ω 1/2W J SMALL RDM92 1Ω 1/2W J SMALL SFR25H 1Ω 1/2W J SMALL CF 1Ω 1/2W J SMALL	RESISTOR, CARBON FILM	ABCO SMART PLKOR TZAI YUAN
155	AI	1	EA	R505	CRS 20Ω 1/2W J SMALL RDM92 20Ω 1/2W J SMALL SFR25H 20Ω 1/2W J SMALL CF 20Ω 1/2W J SMALL	RESISTOR, CARBON FILM	ABCO SMART PLKOR TZAI YUAN
156	AI	1	EA	R101	PRC 1.2MΩ 1/2W J SURGE MSR37 1.2MΩ 1/2W J SURGE	RESISTOR, FIXED CARBON COMPOSITION	SMART PLKOR
157	AI	1	EA	R124	PRC 1MΩ 1/2W J SURGE MSR37 1MΩ 1/2W J SURGE	RESISTOR, FIXED CARBON COMPOSITION	SMART PLKOR
158	AI	3	EA	R251, R252, R253	MORS 10KΩ 2W J SMALL RSD02 10KΩ 2W J SMALL PR02 10KΩ 2W J SMALL MOF 10KΩ 2W J SMALL	RESISTOR, METAL OXIDE FILM	ABCO SMART PLKOR TZAI YUAN
159	AI	1	EA	R126	MORS 120Ω 1W J SMALL RSD01 120Ω 1W J SMALL PR01 120Ω 1W J SMALL MOF 120Ω 1W J SMALL	RESISTOR, METAL OXIDE FILM	ABCO SMART PLKOR TZAI YUAN
160	AI	2	EA	R286, R287	MORS 1KΩ 2W J SMALL RSD02 1KΩ 2W J SMALL PR02 1KΩ 2W J SMALL MOF 1KΩ 2W J SMALL	RESISTOR, METAL OXIDE FILM	ABCO SMART PLKOR TZAI YUAN
161	AI	2	EA	R279, R280	MORS 27KΩ 2W J SMALL RSD02 27KΩ 2W J SMALL PR02 27KΩ 2W J SMALL MOF 27KΩ 2W J SMALL	RESISTOR, METAL OXIDE FILM	ABCO SMART PLKOR TZAI YUAN
162	AI	3	EA	R283, R284, R285	MORS 3.3KΩ 2W J SMALL RSD02 3.3KΩ 2W J SMALL PR02 3.3KΩ 2W J SMALL MOF 3.3KΩ 2W J SMALL	RESISTOR, METAL OXIDE FILM	ABCO SMART PLKOR TZAI YUAN
163	AI	1	EA	R503	MORS 62KΩ 1W J SMALL RSD01 62KΩ 1W J SMALL PR01 62KΩ 1W J SMALL MOF 62KΩ 1W J SMALL	RESISTOR, METAL OXIDE FILM	ABCO SMART PLKOR TZAI YUAN
164	AI	2	EA	R501, R507	WNPS 0.82Ω 1W J SMALL PRN 0.82Ω 1W J SMALL	RESISTOR, WIRE WOUND	ABCO SMART
165	AI	2	EA	R601, R602	WNPS 0.13Ω 2W J SMALL PRN 0.13Ω 2W J SMALL	RESISTOR, WIRE WOUND	ABCO SMART
166	AI	2	EA	R268, R269	WNPS 0.33Ω 2W J SMALL PRN 0.33Ω 2W J SMALL	RESISTOR, WIRE WOUND	ABCO SMART
167	AI	1	EA		EAX64310401 LGP4247H-12LPB 243 x 245 1.6T FR1 KB, DS, L, R-8700 CTI-600	PCB	DUCK SUNG HT CIRCUIT(QINGDAO) DONGMYUNG CIR SHANGHAI WANZHENG SHENG KHUANG NEW TRIUNION TIANJIN DEA DUCK HUIHO HSIANG KUO TIAN FENG TIS KOREA Wellbest Cosmotech Kyosha
168	ETC						SUBSIDIARY MATERIALS

169	ETC	0.0769	EA		509 * 344 * 280 * 8T	BOX CARTON	NEWEA IND DAESAN. HANYOUNG JAEL QXBW TAILI PACKING HUAXING PACK SOONGSAN WUJIANG ZHENLONG SUZHOU JIADELONG KUNSHAN KUNHONG Dongju Yumi
170	ETC	1.0769	EA		341 * 256 * 8T (Cross board A)	BOX PARTITION	NEWEA IND DAESAN. HANYOUNG JAEL QXBW TAILI PACKING HUAXING PACK SOONGSAN WUJIANG ZHENLONG SUZHOU JIADELONG KUNSHAN KUNHONG Dongju Yumi
171	ETC	0.3077	EA		506 * 256 * 8T (Cross board B)	BOX PARTITION	NEWEA IND DAESAN. HANYOUNG JAEL QXBW TAILI PACKING HUAXING PACK SOONGSAN WUJIANG ZHENLONG SUZHOU JIADELONG KUNSHAN KUNHONG Dongju Yumi
172	ETC	0.2307	EA		506 * 341 * 8T	PAD	NEWEA IND DAESAN. HANYOUNG JAEL QXBW TAILI PACKING HUAXING PACK SOONGSAN WUJIANG ZHENLONG SUZHOU JIADELONG KUNSHAN KUNHONG Dongju Yumi
173	ETC	1	EA		Min 600 * 200	BUBBLE SHEET	DUCKJIN S&P JAEL QXBW CHUMDAN A-TEK KUNSHANKUNHONG LYUANG SERVEONE
174	ETC	1	EA		42 X 8 NY WHITE 93CODE 19DIGIT	BAR CODE	SHUN JIN HANA. AIT SERVEONE WUJIANG SUNGLING GUNGGAOQI ZHI XIN
175	ETC	1	EA		19 X 9 NY WHITE MICOM CHECKSUM	LABEL	SHUN JIN HANA. AIT SERVEONE WUJIANG SUNGLING GUNGGAOQI ZHI XIN
176	ETC	15.0	GR		EF-9301(g) ILF-714(kg) TF328-2-2(Kg) EC-19S-8 CS-9111LF	FLUX	ALPHA ION ELEC TONGFANG 동화 다 무라 철술
177	ETC	23.0	GR		HSE-11 B20 BAR (SN:99%,AG:0.3%,CU:0.7%) SN:99%, AG:0.3%, CU:0.7% SAC0307 A+ SN:99%, AG:0.3%, CU:0.7% YW9-0307 SN:99%, AG:0.3%, CU:0.7% M35E-BAR SN:99%, AG:0.3%, CU:0.7%	SOLDER BAR	HEESUNG METAL SEOUL ALLOYMETAL DYFENCO YUNNAN TIN SOLNET
178	ETC	5.0	GR		HSE-11 B20 BAR (SN:99%,AG:0.3%,CU:0.7%) SN:99%, AG:0.3%, CU:0.7% SAC0307 A+ SN:99%, AG:0.3%, CU:0.7% YW9-0307 SN:99%, AG:0.3%, CU:0.7% M35E-BAR SN:99%, AG:0.3%, CU:0.7%	SOLDER WIRE	HEESUNG METAL SEOUL ALLOYMETAL DYFENCO YUNNAN TIN SOLNET
179	ETC	10.0	GR		H-828W OKE-410 QS9112 RTV SS7945W TSE3854DS-W BN707 RTV KE402RTV ES 2044H & 2S2482W UB-5601 EA-4100 DS-818	BOND (RTV)	OKONG OKONG KCC KCC MOMENTIVE BONIC SHINETSU CANADA U-BOND DOW CORNING DONGYANG

Process Marking

공정표시 MARK (PCB SILK)

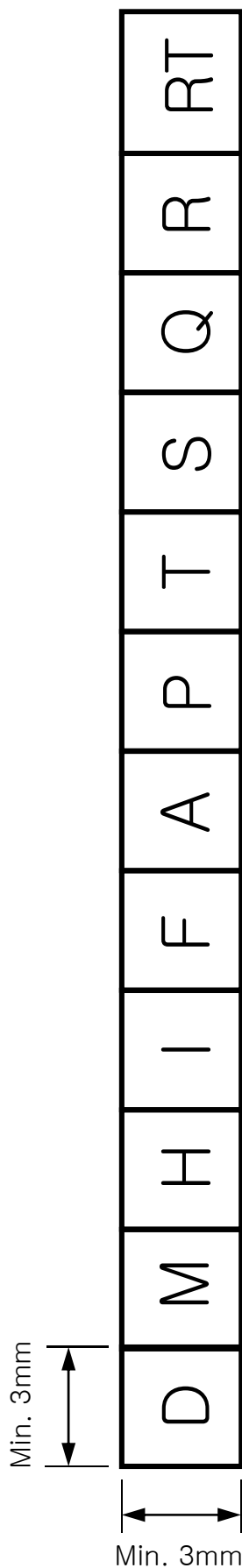

D : 자삽
M : SMD
H : 수삽 최종
I : ICT
F : 1차 성능
A : AGING
P : HI-POT
T : 최종 검사 (ATE)
S : SET 검사
Q : QC 검사
R : 불량 수리
RT : 양산 보증 시험

PCB Layout

Top Silk

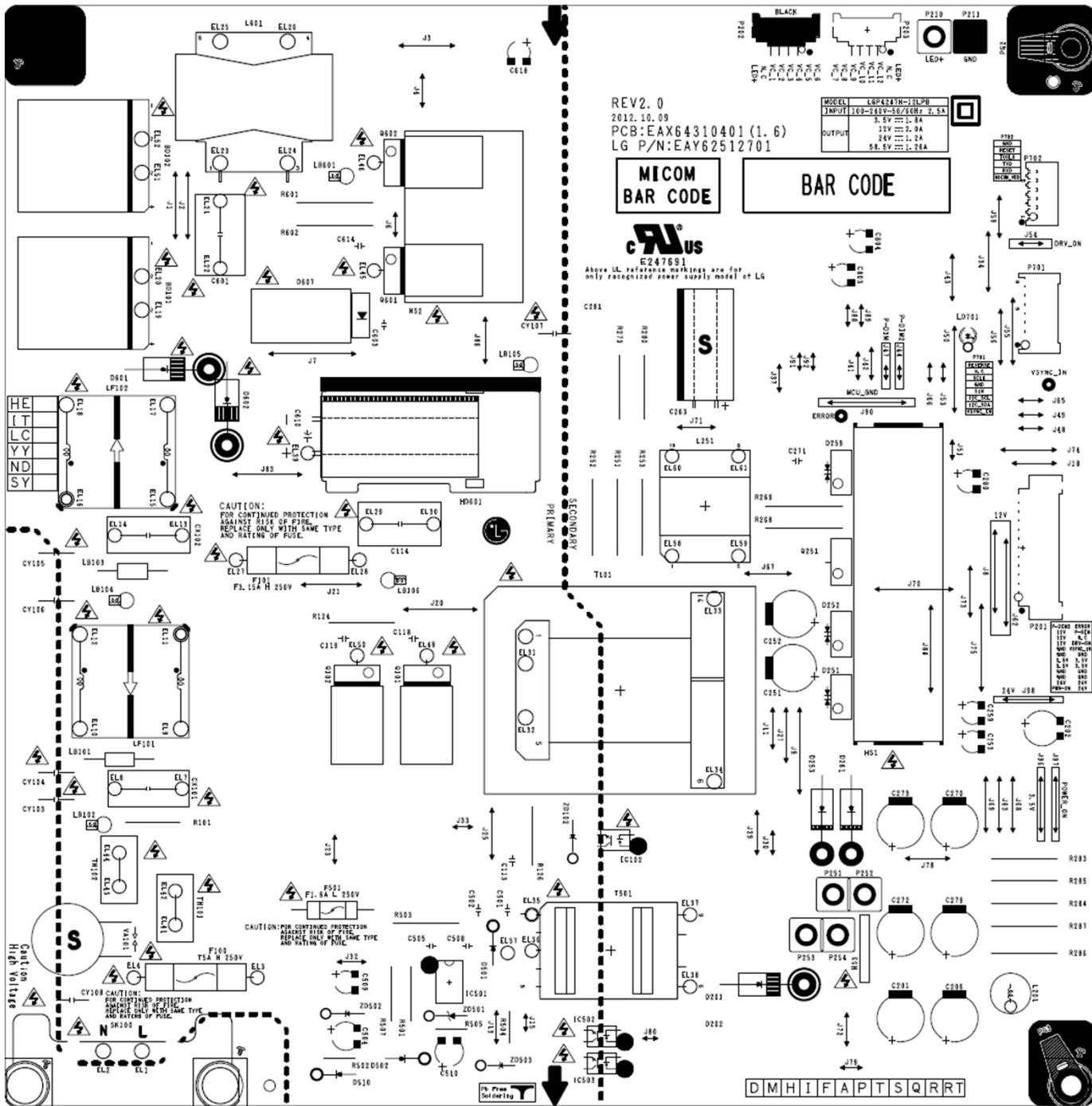

Bottom Silk

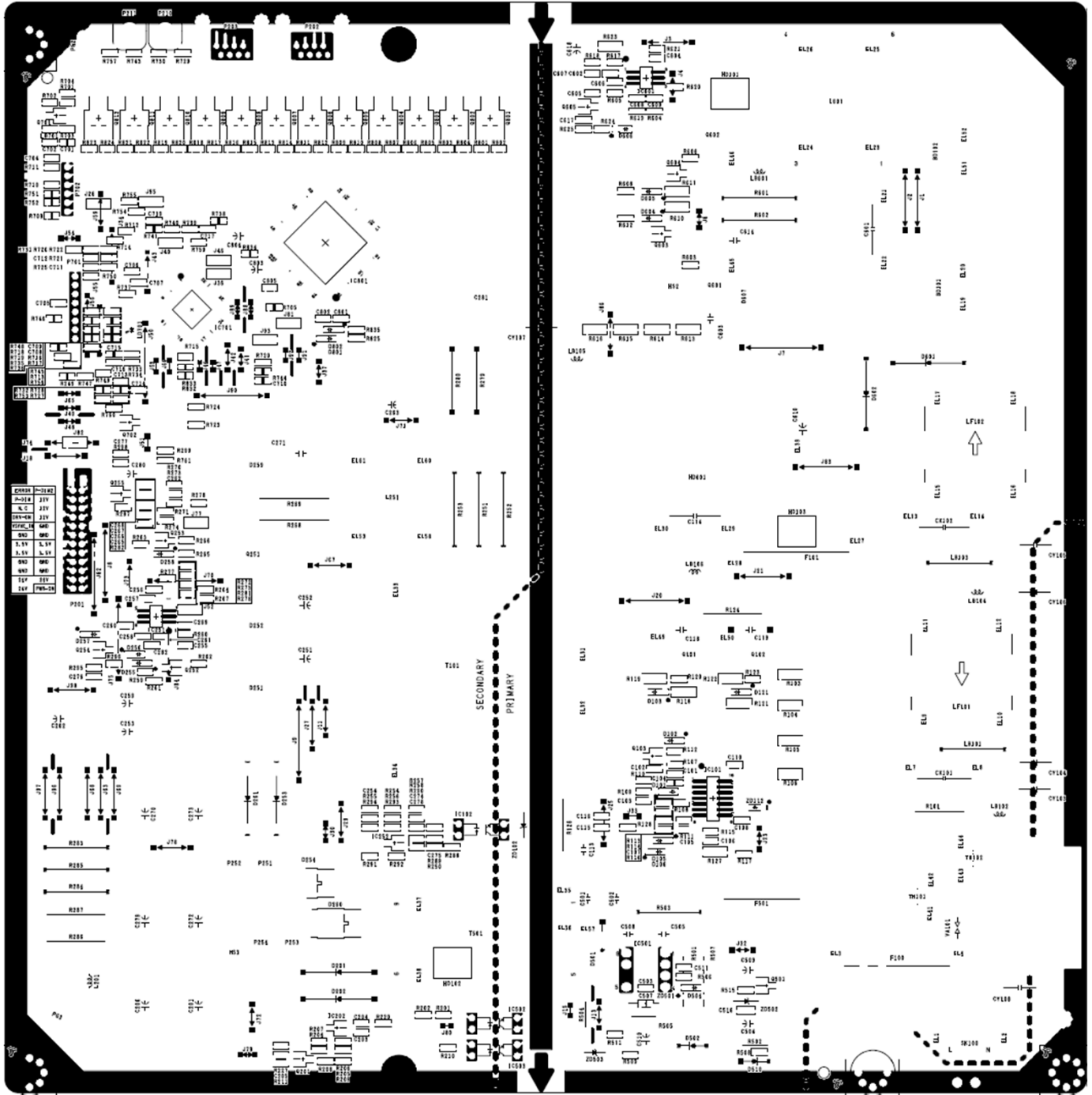

Bottom Pattern

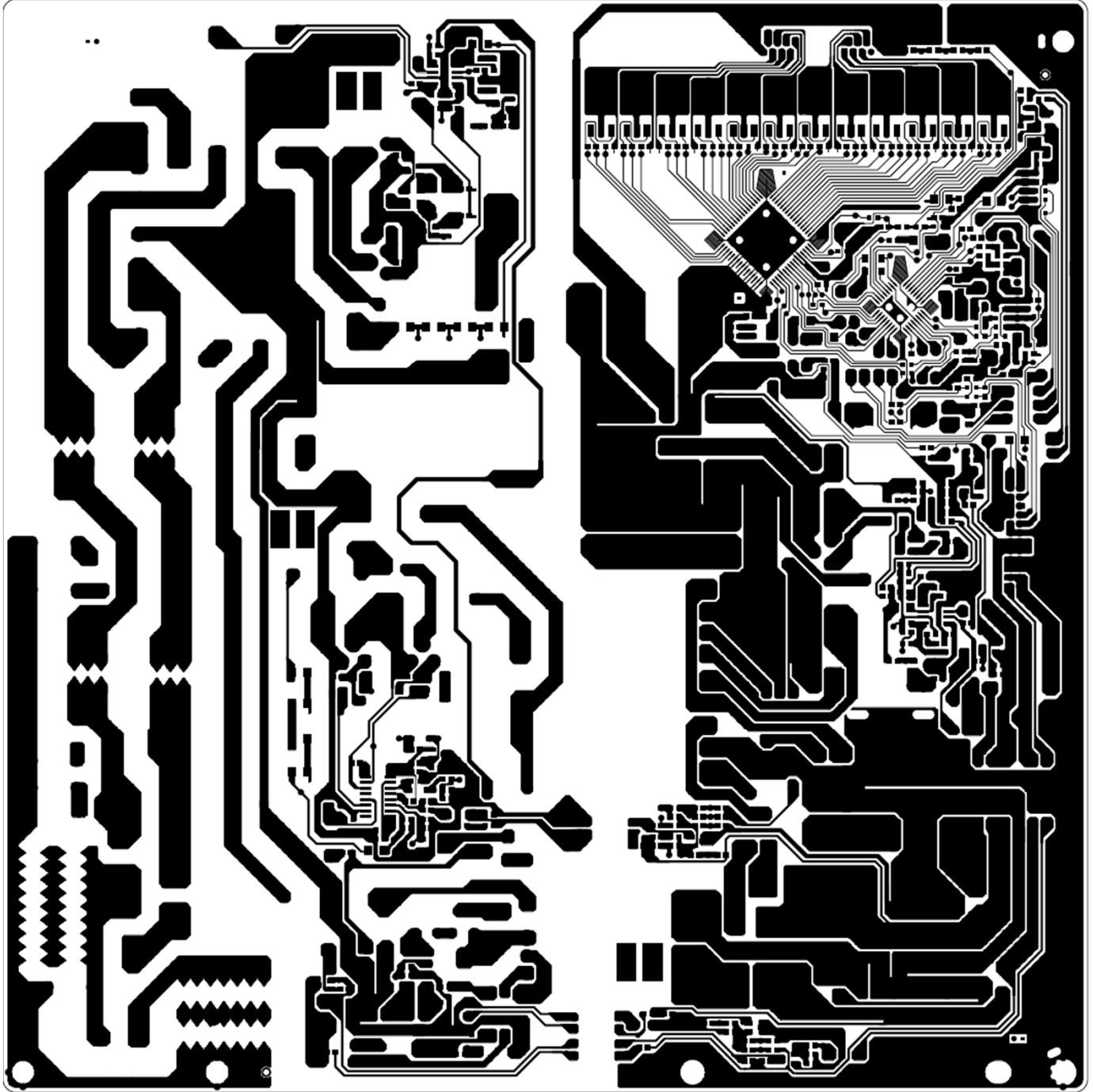

Bottom Solder mask

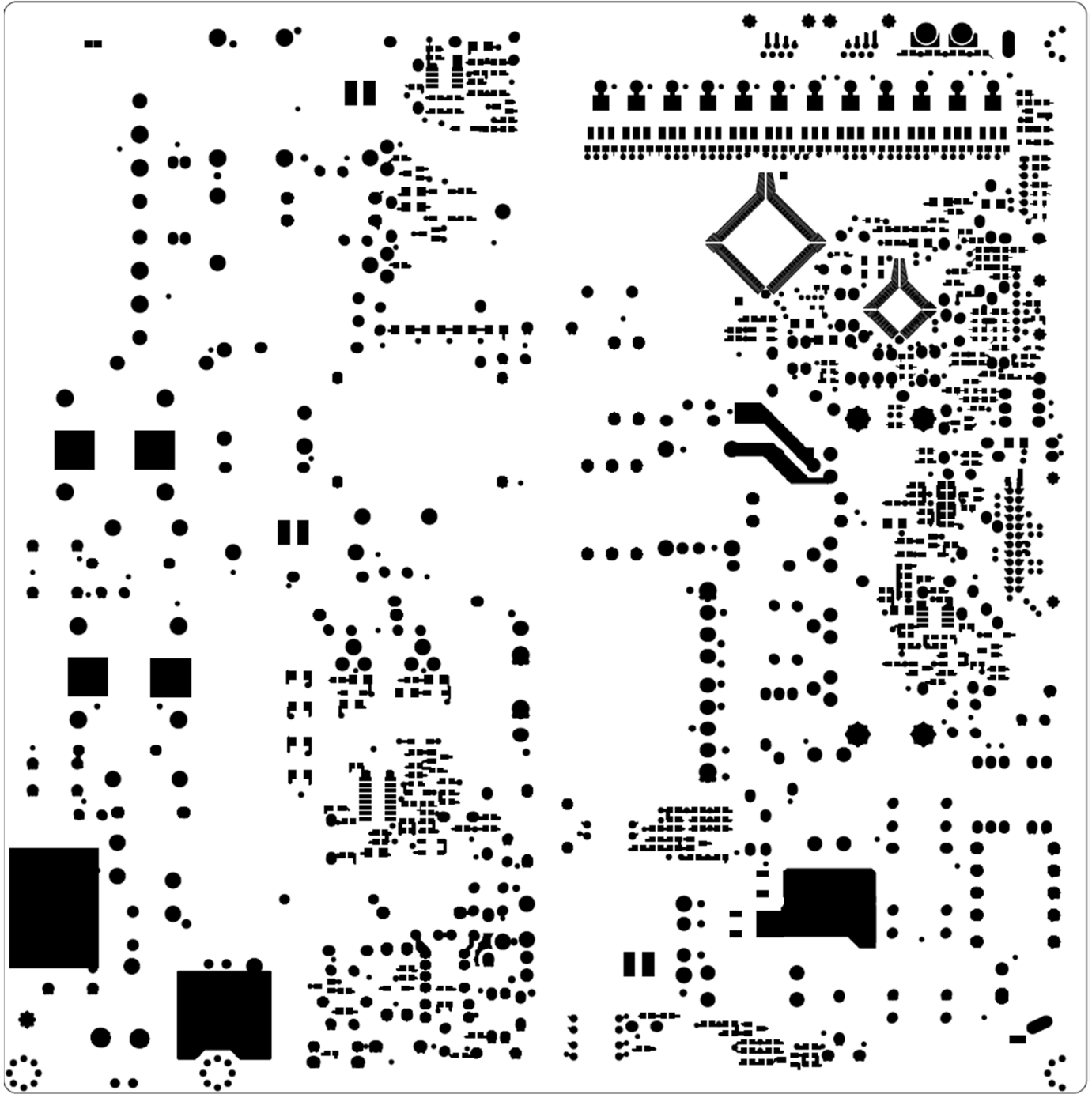

Safety Parts

Object/part No.	Manufacturer / Trademark	Type / Model	Value / Rating	Parts Marking (貨物)	standard	mark(s) of conformity1)
AC input connector, (SK100)	Dongil Tech	DAC-18D3A	250V 2.5A / 5A	2.5A/250V-5A/250V-	IEC 60320-1	
Fuse, (F100)	Littelfuse Inc.	215 Series	T5A H / 250V	LF.T5AH250VP	IEC 60127-1	
	WALTER FUSE	TSC		TSC5A250V(P)	IEC 60127	
	Dainfuse	50CT		T5AH250V	IEC 60127	
	BUSSMANN	S505		T5AH250V	IEC 60127	
	CONQUIRE	UDA / UDA-A		UDA T5A H 250V	IEC 60127-3-5	
Fuse, (F101)	Littelfuse Inc.	216 Series	F3.15A H / 250V	LF.F3.15AH250VP	IEC 60127-1	
	Dainfuse	50CF		F3.15AH250V	IEC 60127	
	BUSSMANN	S501		T3.15AH250V	IEC 60127	
	CONQUIRE	UBM-A		UBM-A 3.15A 250V	IEC 60127-2-1	
Fuse, (F501)	Littelfuse Inc.	876 Series	F1.6A L / 250V	LF1.6A F250V	IEC 60127-1	
	Dainfuse	30CF		F1.6A 250V	IEC 60127	
Line Filter, (LF101,LF102)	TNC	CS920250S	Rated 130°C	920250S	IEC 60065	Test in appliance
	Dongil Tech	LH9B020250		020250	IEC 60065	Test in appliance
	DONGYANG TELECOM	LLF-121		LLF-121		
	JIANGSU CHANNELON ELECTRONIC GROUP					
	FEELUX					
	SOOJUNG					
JIANGSU TAICHANG ELECTRONICS Co.,LTD.						
Varistor, (VA101)	Samwha	SVC621D-14	620V,Min.	SVC621-14	IEC61051-2	
	Amotech Co., Ltd.	INR 14D621		INR 14D621		
	Xiamen Wanming Electronics Co.,Ltd	WMR14D621K		WMR 14D621K		
Bridge Diode, (BD101,BD102)	Rectron	RS1005M	Min. 600V / 10A	RS1005M	E94233	
	TSC	TS10B05G		TS10B05G	E96005	Test in appliance
	Lite-on	KBJ1006G		KBJ1006G	E142422	
	SHINDENGEN	D10XB60		D10XB60		
	GULF	G10XB60		G10XB60		
	DACHANG	D10XB60		D10XB60		
X-cap. (CX101,CX102)	Pilkor	PCX2 337	275V Max 0.33uF (CX101= 0.33uF, CX102= 0.33uF)	PCX2 337	IEC 60384-14 UL1414	
		PCX2 335M		PCX2 335M	IEC 60384-14 UL1414	
	SUNGHO	CMPP		CMPP	IEC 60384-14 UL1414/UL1283	
	Okaya	LE		LE	IEC 60384-14 UL1414	
	EUROPTRONIC	MPX		MPX	E199061/ E311052 IEC 60384-14-2'nd edition	
	CHENG TUNG	CTX		CTX	IEC 60384-14 UL1414	
Thermistor. (TH101,TH102)	DSC	DSC 2.5D-15	2.5ohm at 25 ° C	DSC 2.5D-15	IEC 60065	
	Xiamen Wanming Electronics Co.,Ltd	WTR 15D2R5		WTR 15D2R5		
	JIANGSU XINGSHUN ELECTRONICS CO., LTD	2.5D2-15		2.5D2-15		
	NANJING SHIHENG ELECTRONICS CO., LTD	MF72 2.5D15		MF72 2.5D15		
	SMART ELECTRONICS INC	ICL-5W	2.5ohm at 25 ° C	ICL-052R50MSMT		

Elec. Cap., (C610)	SAMYOUNG	NZE	450V / Max 120uF / 105°C	NZE450V120uF	IEC 60950-1	Test in appliance
	SUSCON	SK		SK450V120uF		
	SAMWHA	LT		LT450V8120uF		
	RUBYCON	BXC		BXC450V120uF		
Switching TR, (Q601,Q602)	INFINEON	IPA60R280E6	Min. 600V / Min 10A	6R280E6	IEC 60950-1	Test in appliance
	TOSHIBA	TK13A60D		K13A60D		
	STM	STF13NM60N		I3NM60N		
	SILIKRON	SSF11NS60F		SSF11NS60F		
Switching TR, (Q101,Q102)	KEC	KF12N60F	Min. 600V / Min 10A	KF12N60	IEC 60950-1	Test in appliance
	TOSHIBA	TK12A60D		K12A60D		
	STM	STF13NM60N		I3NM60N		
	MAGNACHIP	MDF11N60		MDF11N60		
INFINEON	SD10N60	SD10N60				
Flyback IC, (IC501)	SANKEN	STR-A6059H	Min. 650 V / Min 1.8A	A6059H	IEC 60950-1	Test in appliance
Y Cap., (CY103,CY104, CY105,CY106)	Kunshan Wansheng	Y1 / CT7		CT7 471K		
	Apex intec	Y1 / NK		NK471K		
	DONG IL	Y1 / DA		DA471K		
	YINANDON	Y1 / CT81		CT81 471K		
	SAMWHA	Y1 / SD		SD471K		
	JYA-NAY	Y1 / JN		JN471K		
	GUANGDONG SOUTH HONGMING	Y1 / F		F471K		
	TDK	Y1 / CD		CD471K		
Y Cap., (CY108)	Kunshan Wansheng	Y1 / CT7		CT7 101K		
	Apex intec	Y1 / NK		NK101K		
	DONG IL	Y1 / DA		DA101K		
	YINANDON	Y1 / CT81		CT81 101K		
	SAMWHA	Y1 / SD		SD101K		
	JYA-NAY	Y1 / JN		JN101K		
	GUANGDONG SOUTH HONGMING	Y1 / F		F101K		
	TDK	Y1 / CD		CD101K		
Bridging Cap., (CY107)	Kunshan Wansheng	Y1 / CT7		CT7 471K		
	Apex intec	Y1 / NK		NK471K		
	DONG IL	Y1 / DA		DA471K		
	YINANDON	Y1 / CT81		CT81 471K		
	SAMWHA	Y1 / SD		SD471K		
	JYA-NAY	Y1 / JN		JN471K		
	GUANGDONG SOUTH HONGMING	Y1 / F		F471K		
	TDK	Y1 / CD		CD471K		
PFC Coil,(L601)	SOOJUNG	12S-LP03	Rated 130°C	12S-LP03	IEC 60950-1	Test in appliance
	BUJEON					
	DONG YANG TELECOM CO., LTD					
	LG Innotek					
	JIANGSU CHANNELON ELECTRONIC GROUP					
	TDK					
	FEELUX					
	JIANGSU TAICHANG ELECTRONICS Co.,LTD.					
LIENCHANG						
Switching Transformer, (T101)	SOOJUNG	12S-LM03	Class B	12S-LM03	IEC 60950-1	Test in appliance
	BUJEON					
	DONG YANG TELECOM CO., LTD					
	LG Innotek					
	JIANGSU TAICHANG ELECTRONICS Co.,LTD.					
	JIANGSU CHANNELON ELECTRONIC GROUP.					
	TDK					
	FEELUX					
LIENCHANG						

Switching Transformer, (T501)	SOOJUNG	12S-LS01	Class B	12S-LS01	IEC 60065	Test in appliance
	BUJEON					
	DONG YANG TELECOM CO., LTD					
	JIANGSU CHANNELON ELECTRONIC GROUP.					
	TDK					
	FEELUX					
	JIANGSU TAICHANG ELECTRONICS Co.,LTD.					
Clover hi-tech Co., Ltd.						
LIENCHANG						
Opto-coupler, (IC102, IC502, IC503)	Everlight	EL817	>0,4mm / Rated 6000Vac	EL817	IEC 60065 UL 1577	
	Lite-on	LTV817...		S17BN		
Discharge Resistor, (R101)	Smart	PRC	1/2W, 1.2Mohm, 5%		IEC 60065	
	UNIROYAL ELECTRONICS INDUSTRY CO., LTD	MGR0W2J****A10			IEC 60065	
	Pilkor	SR37,MSR37			IEC 60065	
Capacitor (C601)	Pilkor	FCMP 372 (box) FCMP 472 (Film)	0,82uF / 500V	820n J 500V 372 MKP 824 J 500 P472 MPP	IEC60384-1	UL
	LUMEN	MP	0,82uF / 500V	M 824J MP 500V		
	EUROPTRONIC	MPHB	0,82uF / 500V	MPHB 824 J 500		
	Sung-Ho	MPP BMPP	0,82uF / 500V	824J 500V S MPP 824J 500V BMPP SH		
CHENG TUNG	CTH	0,82uF / 500V	CTH 824 J 500V			
Capacitor (C114)	Pilkor	FCMP 384	0,018uF / 800V	18n J 800V 384 MMKP	IEC60384-1	UL
	LUMEN	NP	0,018uF / 800V	M 183J NP 800V		
	EUROPTRONIC	MPLB	0,018uF / 1000V	MPLB 183 J 1000		
	Sung-Ho	NPPS	0,018uF / 800V	183J S 800V NPPS		
CHENG TUNG	PPN	0,018uF / 800V	PPN 183 J 800V			
PCB	DONGMYUNG CIR.	DM5-V-0	04V-0			
	SHANGHAI WANZHENG	SWZ-2	04V-0			
	SHENG KHUANG(WEI JUN)	03V0-C 03V0	04V-0			
	SHANGHAI AREX	02V0	04V-0			
	NEW TRIUNION	TU-3	04V-0			
	CHIN POON	E5	04V-0			
	TIANJIN DAEDUCK	DC-1 DC-2	04V-0			
	HUIHO	4B-5	04V-0			
	HSIANG KUO	07V0	04V-0			
	SAMHAN	SH7	04V-0			
	HT CIRCUIT(QINGDAO)	1994V0	04V-0			
	WONKYUNG	WK-1	04V-0			
	TIAN FENG	TU-1	04V-0			
	Duck sung	DSS-V-0	04V-0			
	TIS KOREA	TIS-3	04V-0			
	kyosha	2204V-0	04V-0			
	kyosha	S4504V-0	04V-0			
	Wellbest	MTV0-01	04V-0			
	Cosmotech	GS2-V-0-1 CJ2-V-0-1 CJ2-V-0-2	04V-0			
	CHANGZHOU HAIHONG	CCE-V0	04V-0			

1) an asterisk indicates a mark which assures the agreed level of surveillance
Remarks: *) Large volume capacitors exceeding volume 1750mm³

Mechanical Drawing

THIS DOCUMENT CONTAINS PROPRIETARY INFORMATION AND MAY NOT BE REPRODUCED WITHOUT THE EXPRESS WRITTEN PERMISSION OF A DUTY AUTHORIZED REPRESENTATIVE OF LG ELECTRONICS.

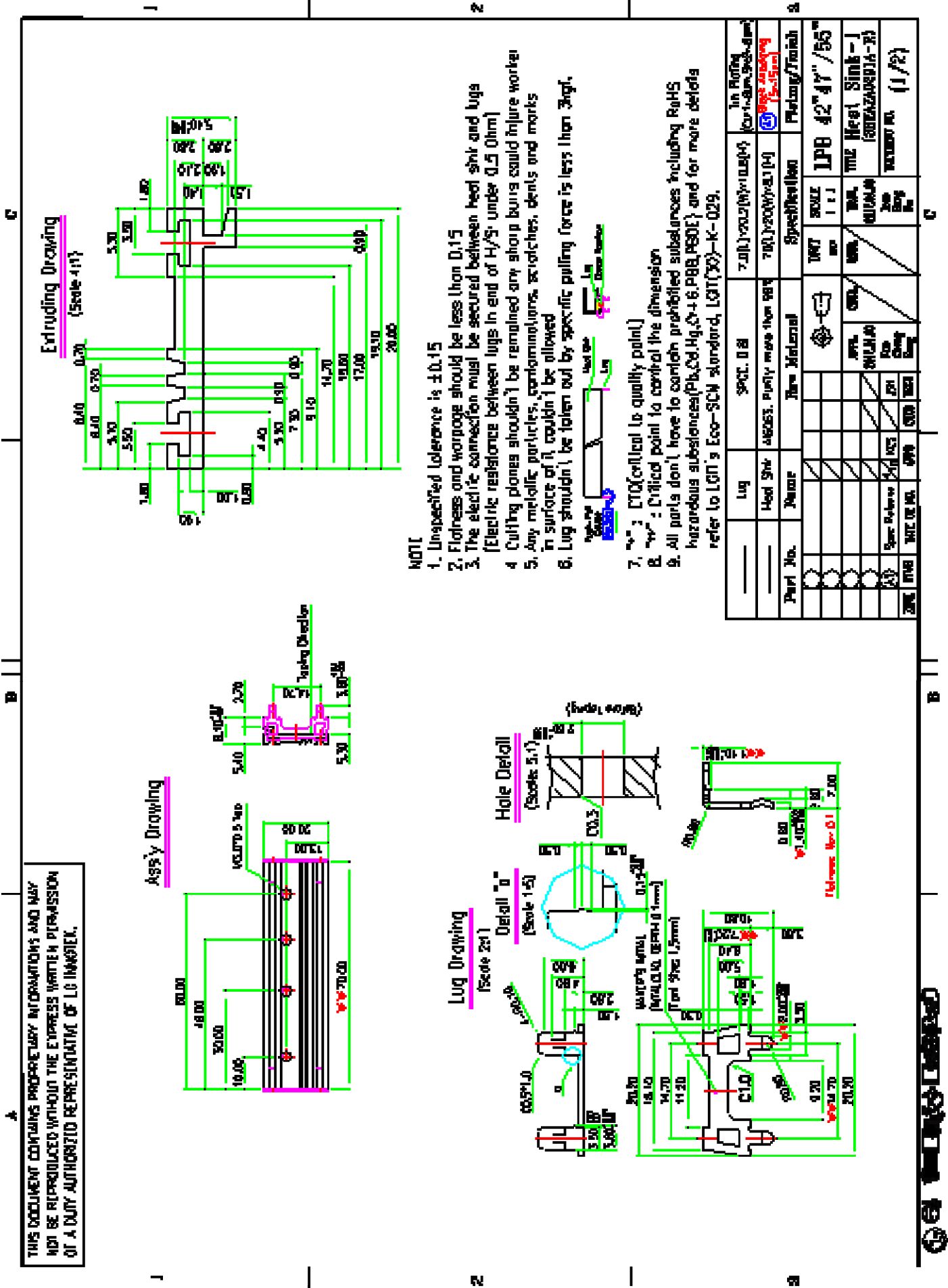

A

B

C

THIS DRAWING CONTAINS PROPRIETARY INFORMATIONS AND MAY NOT BE REPRODUCED WITHOUT THE EXPRESS WRITTEN PERMISSION OF A DUTY AUTHORIZED REPRESENTATIVE OF LG INNOVTEK.

Ass'y Drawing
(Scale 1:1)

Extruding Drawing
(Scale 4:1)

Pin Drawing
(Scale 5:1)

Hole Detail
(Scale: 5:1)

NOTE

1. Unspecified tolerance is ± 0.2 .
2. Flatness and warpage should be less than 0.15.
3. The electric connection must be secured between heat sink and pin.
(Electric resistance between pin in end of H/S& under 0.5 Ohm)
4. Curling planes shouldn't be remained any sharp burrs could injure worker
5. Any metallic particles, contaminations, scratches, dents and marks in surface of it couldn't be allowed
6. Pin shouldn't be taken out by specific pulling force is less than 3kgf.
(Refer to below details)

7. Lugs should not be cut out over Heat sink Body boundary
8. Cu , Ni , Pb , Ag , CTC(certified to quality point)
9. Cu , Ni , Pb , Critical point to control the dimension

10. All parts don't have to contain prohibited substances including RoHS hazardous substances(Pb,Cd,Hg,Cr+6,PBB,PBDE) and for more details refer to LGI's Eco-SM standard. LGI(SO)-K-029.

Part No.	Pin	QC: 013	5.5(1.200)	Tin Plating (Def: 0.015~0.020mm)
	Heat Sink	AR0085, Purify more than 99%	304(2.250)X3.5(0.914)	C 100% RoHS 100% (2/2)
	Material	Raw Material	Specification	Plating/Finish
			UNIT	FORM
			mm	F=1
			mm	mm
			mm	mm
			mm	mm
			mm	mm
			mm	mm
			mm	mm
			mm	mm
			mm	mm
			mm	mm

LPB 42" 47" /66"
Heat Sink-2
(SPEAKERS-2)

REVISION (2/2)

LG

Packing Drawing

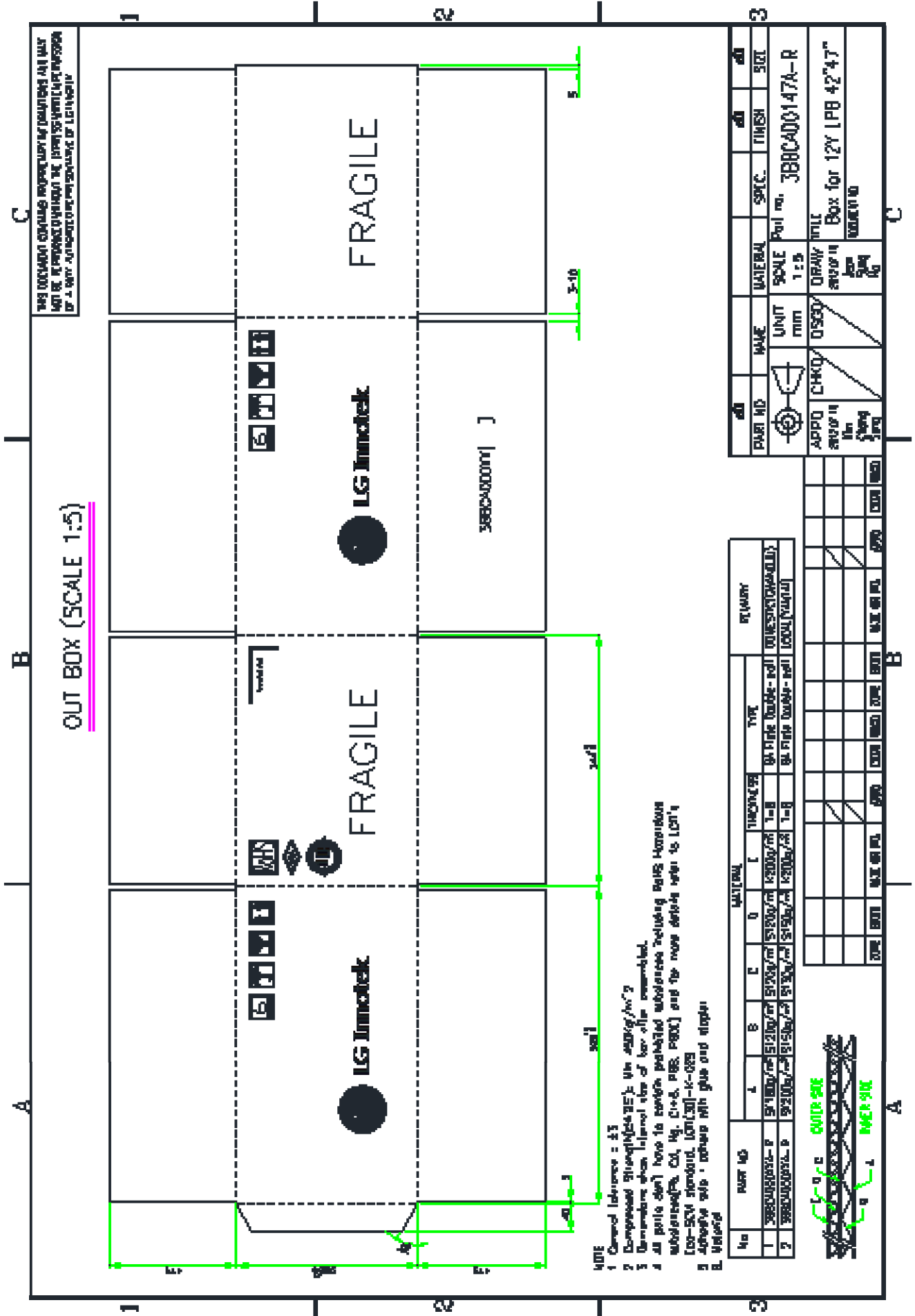

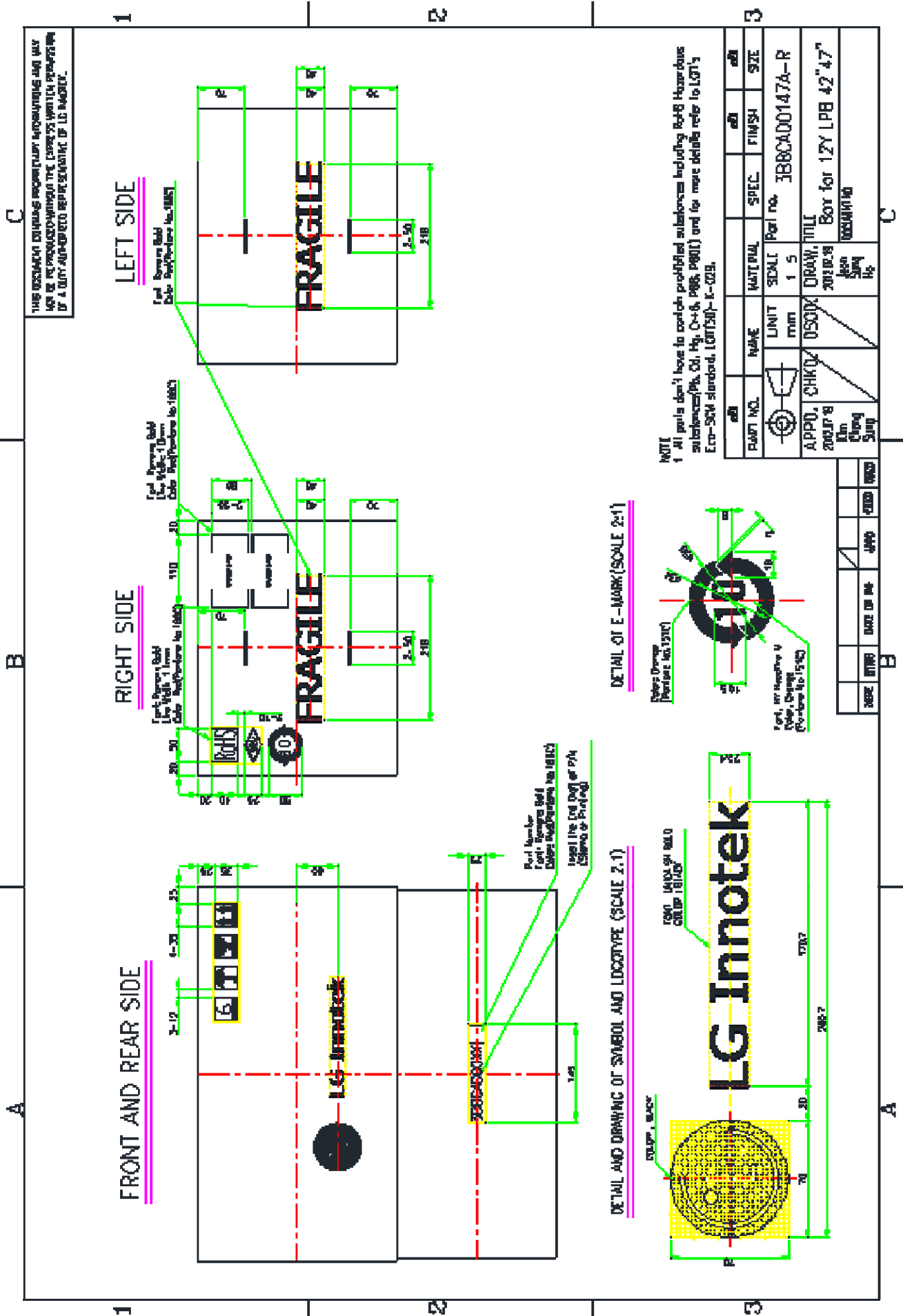

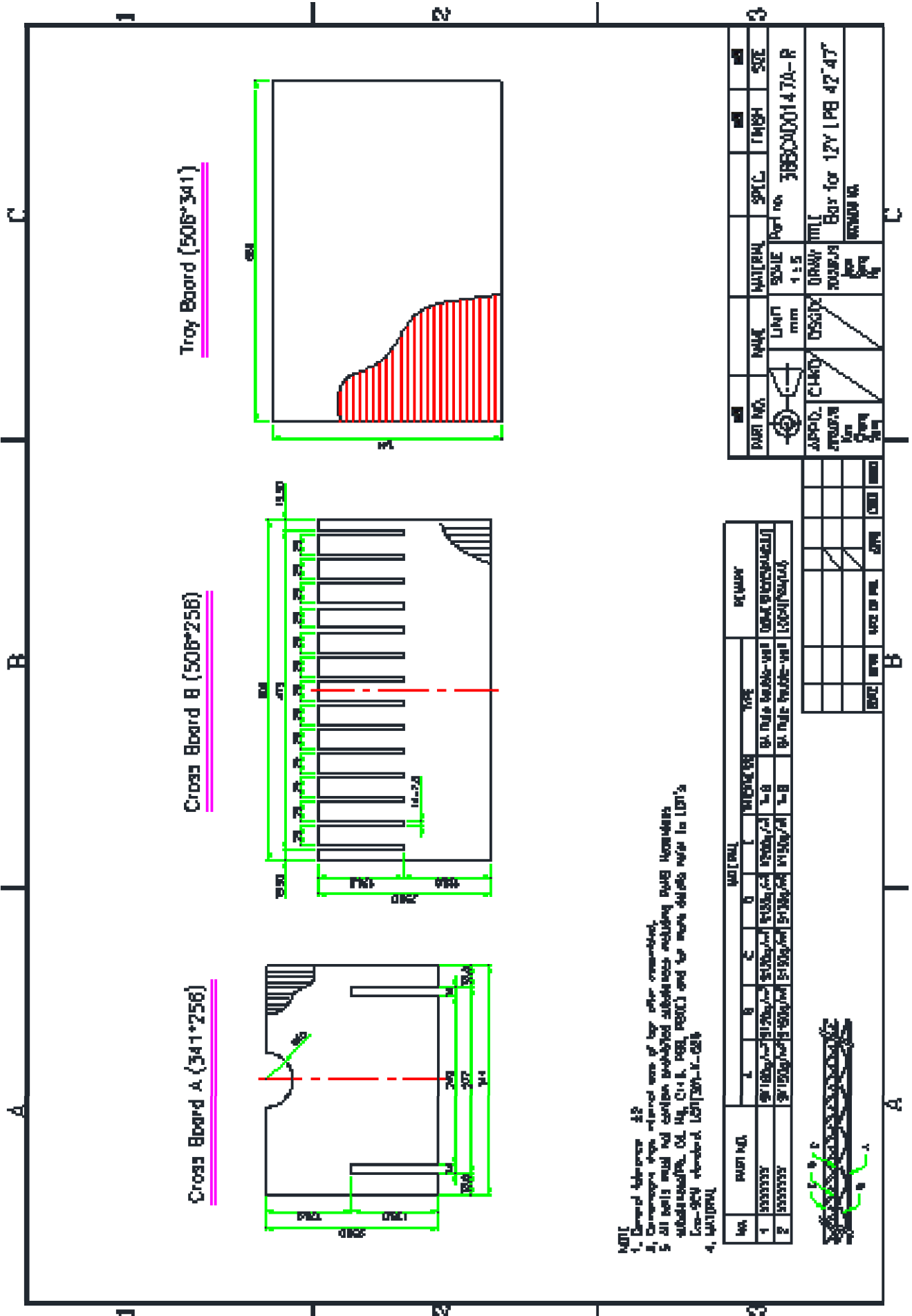

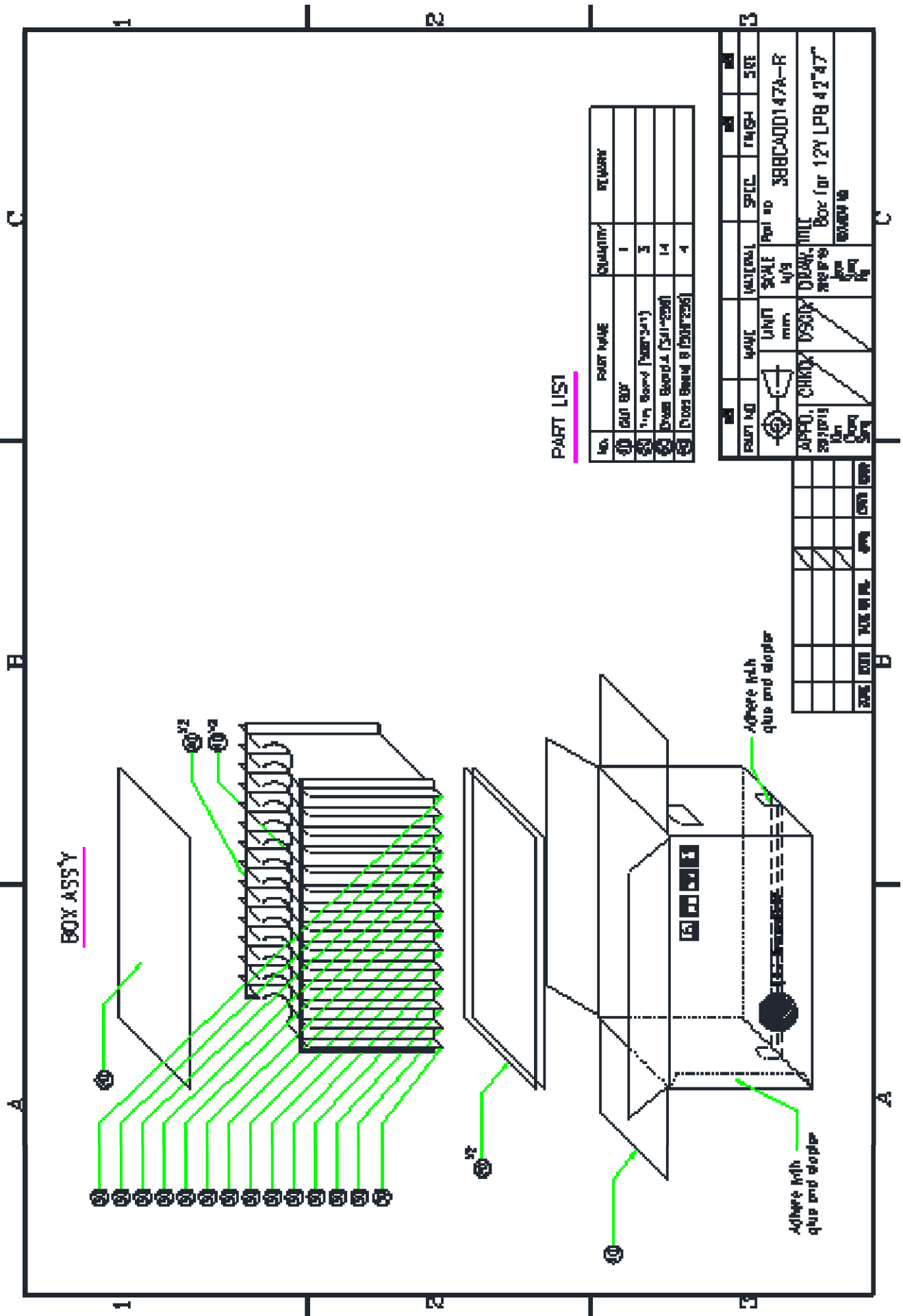

PART LIST

No.	PART NAME	QUANTITY	REMARK
10	FRONT BOX	1	
11	TV Box (PART 241)	3	
12	Power Board (241-220)	1-4	
13	TV Box Board (201-225)	4	

PART NO	NAME	UNIT	QTY	REMARK	DATE	BY
10	FRONT BOX	mm				
11	TV Box (PART 241)	mm				
12	Power Board (241-220)	mm				
13	TV Box Board (201-225)	mm				

DATE	BY	DATE	BY	DATE	BY

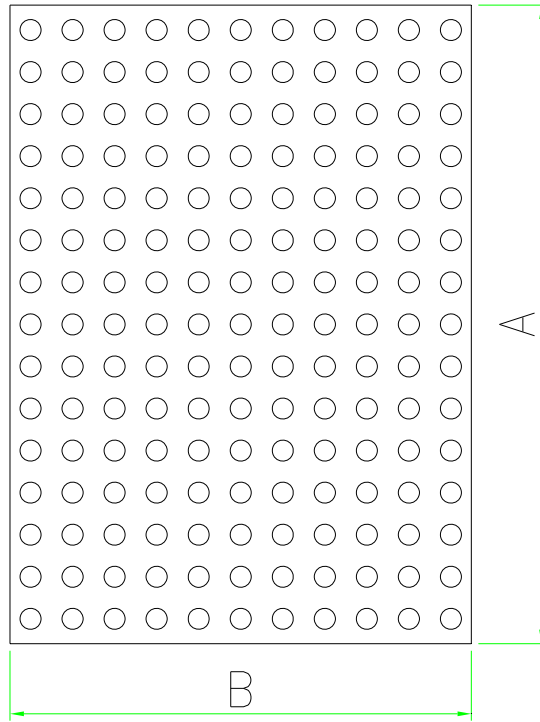

NOTE

1. Material : LDPE
2. General tolerance :
3. COLOR : PINK
4. Antistatic finishing $\begin{matrix} +5 \\ -5 \end{matrix}$
5. Surface Resistance : $10^6 \sim 10^{11}$ Ohm/SQ
All parts must not contain prohibited substances including RoHS azardous substances (Pb, Cd, Hg,Cr+6, PBB, PBDE) and for more details refer to LGIT's Eco-SCM standard,
6. LGIT (30)-K-029.

Part NO.	Thickness	"A"	"B"	Application Model	LGIT PCB Part Number
A	4 ±1.5	400	225	EPSU 32/37(162L*195W)	3EBDDB0001A-R
B	4 ±1.5	585	220	EPSU 42/47(245L*159W)	3EBDDB0002A-R
C	4 ±1.5	620	200	EPSU 55(270L*159W)	3EBDHA0001A-R
D	4 ±1.5	585	270	LPB 42/47(245L*243W)	3EBDDB0003A-R
E	4 ±1.5	585	220	LPB 42/47 Low(245L*174W)	3EBDDB0002A-R
F	4 ±1.5	620	270	LPB 55(270L*242W)	3EBDDB0003A-R
G	4 ±1.5	620	200	LPB 55 Low(270L*176W)	3EBDHA0001A-R

PART NO.		NAME		MATERIAL			SPEC.		FINISH	SIZE
							UNIT mm	SCALE NS		
						APPD. 12.04.02 Kim Chang Sung	CHKD.	DSGD.	DRAW. 12.04.02 Jeon Sung Ho	TITLE Air Vinyl for 12Y
ZONE	SYMB	DATE OR NO.	APPD	CHKD	DSGD					DOCUMENT NO. _____

LG Innotek Co., Ltd.

Bar-Code Label Drawing

1. BARCODE Specification

1.1 Power Board Barcode specification

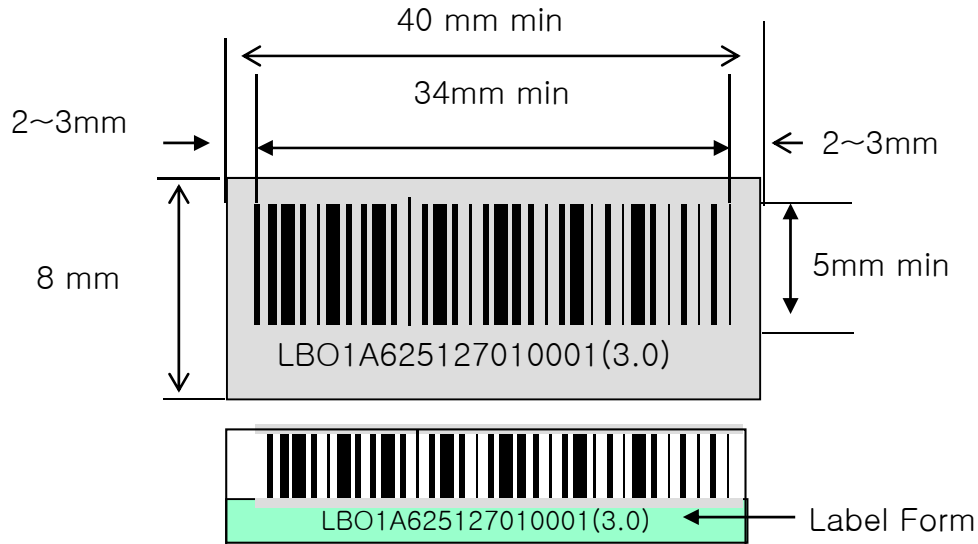

※ Bar Code Size는 그림의 size가 최소size이며, 업체 기준 및 PCB공간에 따라 변경 할 수 있으나, 그림의 size보다 줄일 수는 없음.

Code	Barcode Specification	Remark
Manufacturing code	L (L : LGIT)	
Manufacturing Year	B (B : 2011)	
Manufacturing Month	O (1,2,3,... 10:O, 11:N, 12:D)	
Manufacturing Date	1 (1~9,... A:10, B:11, C:12, ...X) * Don't USE : "I" ,"O" Character	
Manufacturing Line	A~D : Gwangju , E~N / 0~9 : Yantai , O~V : Indonesia , X~Z : Poland	
LG Part No.	62512701 (EAY62512701)	
Serial. No.	0001 (10Digit, 0001~9999)	
Rev. No	Approval Sheet Revision Number	
Barcode type : 93 code Barcode length : 17 digit Label size : 8 X 36 mm (minimize)		

※ BARCODE PRINTING : DO NOT ERASE, WHEN RUB BY HAND.

※ Label P/N : 3320KE0008B

Ribbon Black R300 P/N : 5250KR0011A

Labeling Point

LABELING POINT

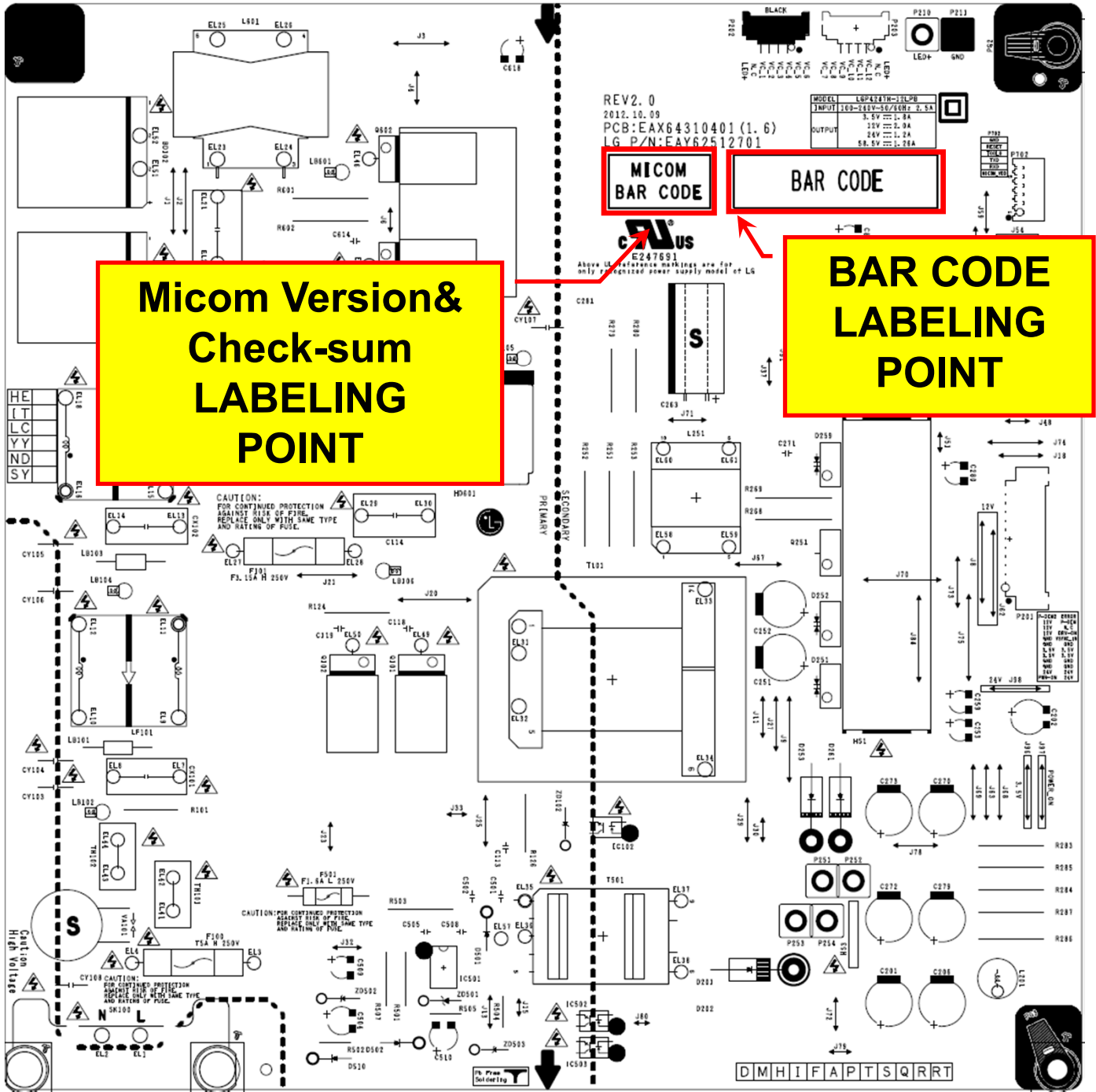

Workmanship Point

Silicone Bonding Point ()

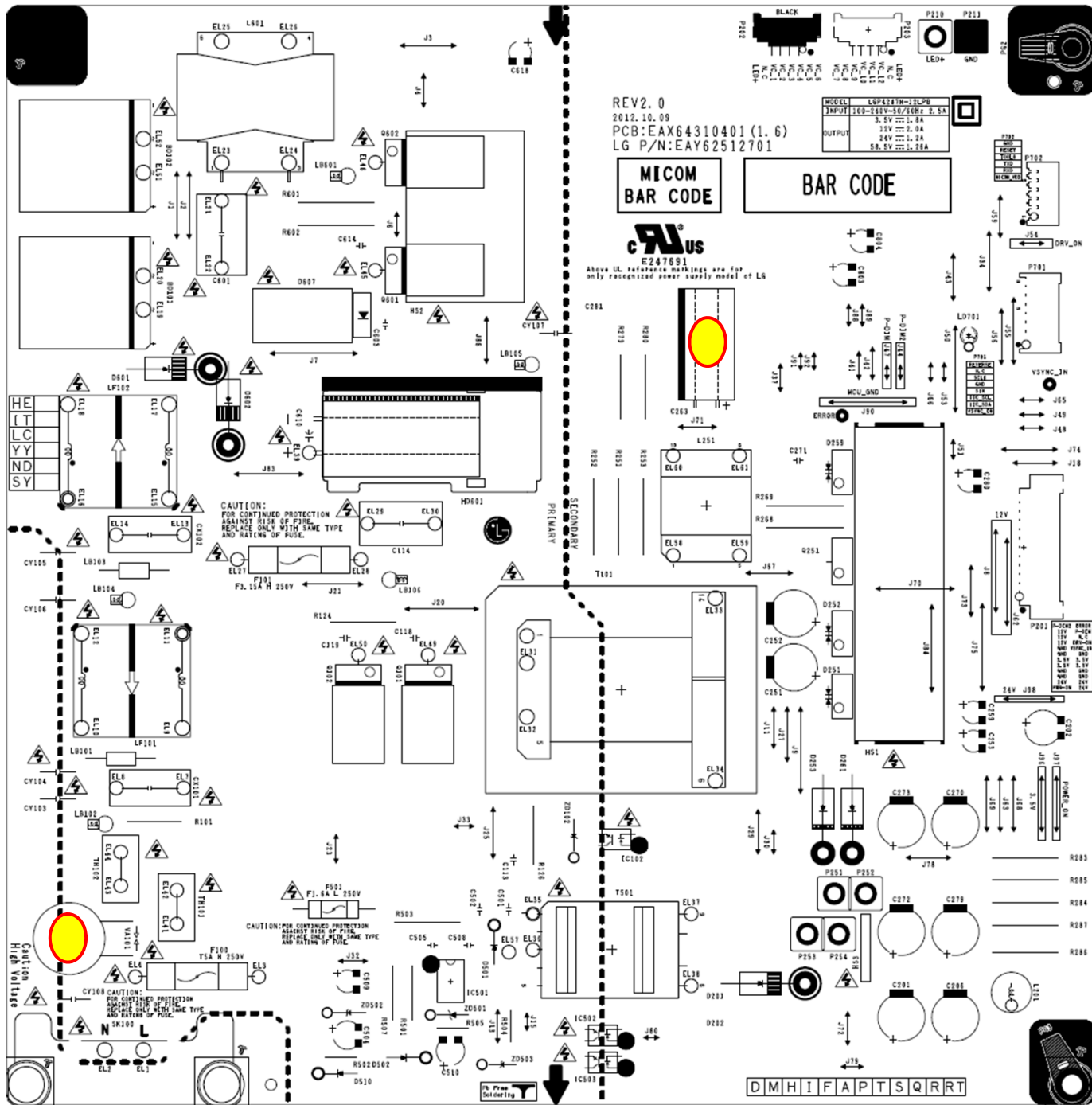

Manufacturing Process

Manufacturing Process

개칭사유		개칭No.				
일자						
11.08.24						
최초제정	0					
관리 No. : P.LDF-L101A / P.LDK-L102A/P.LDF-L103A/P.LDK-L104A 품목 : LGIT 작성자 :						
4M CC 공정도						
작성일 : 11.08.24						
4M						
공정번호	공정명	작업내용	MAN (시달)	Machina (장비)	Material (재료)	Method (방법)
1	Incoming material	해당 모델의 부품 부분과 수량을 확인하고 Box 해체 후 Tray에 적어 [자재 준비]		적입대, 이동대차, 라벨프린터, 스케너	부품	수령, 포장상태, 부분, Lot 상태, 일자
2	[Eyelet]	PCB에 Eyelet, GT Pin을 삽입		Eyelet M/C	Eyelet	일상점검표 기중진한 Sheet 표준검사일자 수리일도
3	[Jump Wire]	PCB에 Jump Wire를 삽입 후 클린팅		Jump Wire M/C 비전 검사(ACI) 바니어 캘리퍼스 각도 측정 지그	Jump Wire	Clinching 길이: 54.0-54.2mm Cinching 각도: 15-35° 중복 삽입, 미삽 회용 것
4	[Sequence]	Axial 자재를 주사의 극성에 맞게 Tape로 연결		Sequence M/C 바니어캘리퍼스	Axial 부품	테이핑 시수 : 54.5-55mm 부품 치수정 : 0.3mm 이하 부품 간격: 5mm
5	[Axial]	PCB에 Axial 부품을 삽입 후 클린팅		Axial M/C 비전 검사(ACI) 각도 측정 지그 바니어캘리퍼스	부품 Sequence	Cinching 길이: 2-1.5mm Cinching 각도: 15-35° 삽입, 미삽 발생하지 않을 것
6	[이행 거상]	PCB에 이행 부품을 삽입 후 클린팅		M10 M/C 바니어캘리퍼스	이행 부품	Cinching 길이: 2-1.5mm 부품 거리 : 6-6.5mm 삽입, 미삽 발생하지 않을 것
7	[Radial]	PCB에 Radial 부품을 삽입 후 클린팅		Radial M/C 비전 검사(ACI) 비전 검사(ACI)	Radial 부품	부품 부품, 방향, 위치 확인 Cinching 길이: 2-1.5mm 부품 거리 : 6-6.5mm PCSB의 극성 일치 삽입, 미삽 발생하지 않을 것

* Process Symbols : ▽(Incoming), ○ (Working Flow Chart), ◇ (Inspection), □ (Packing), ▷ (Delivery)

작성	검 토	승 인
/	/	/

Manufacturing Process

제 / 개 / 정		개정사유		개정No.		작성 / 검토 / 승인	
11.08.24		최초제정		0		/ / /	
관리 No. : 도면명 : PLDF-L107A / PLDK-L102A/PLDF-L103A/PLDK-L104A 품목 : 4M CC 공장도 제조사 : LGIT 작성자 :							
4M							
공정번호	공정	공정내용	MAN (사양)	Machos (장비)	Material (재료)	Method (방법)	
1	[자재준비]	해당 모델의 부품 부합과 수량을 확인하고 Box 또는 후 Tray에 적지	[X]재 준비	인도장 계량장 부품보관대/이동대차 바코드 스캔	부품	수령 포장상태, 부분 Lot 상태, 일자 LGIT PIN Label 확인 BOM/MSD Level	제조 장고 오프 리스트 형별 입고고 관리 리스트
2	[Solder Cream]	Solder Cream 보관 및 사용		냉장고 Thermometer	Almit (LFM-48W TM+HF(L)) -Sn-Ag3.0-Cu0.5	냉도 관리 환경 : 1~10℃ -(이계통시) 생산일시 6개월까지 사용가능 상온방치 2시간이상 포장시간 60초 ~120초	냉장 온도 관리 Sheet 관리라벨 사용 이력 관리
3	[Chip Bond]	Chip bond 보관 및 사용		냉장고 Thermometer	Chip Bond	냉도 관리 환경 : 1~10℃ 상온방치 2시간이상	형상정밀표 수리일보
4	[본드 인쇄]	Stencil Mask를 Printer에 장착하고 그위에 Bond를 투입한 후 PCB를 Loader로부터 공급 받아 Squeegee로 접착제를 장부 치에 인쇄		Mask Bond 인쇄기 Squeegee	Chip Bond	마스크 번호 Mask 2016 후 사이즈 : 0.8mm 3216 후 사이즈 : 1.2mm 접착제 : 보탈명 : HF-100UL 주도 생산시 투입량 : 300g 2H01다 양 제크 후 보충 : 100g~250g	마스크 입고시 확인 투입 Check Sheet
5	[Chip Mount]	합본된 PCB 위에 Chip 장착		Chip Mounter	부품	스루홀의 입자와 속도 조정 (조건표) 인쇄 상태 확인 Squeegee No. (조건표) 마스크 세척	고정밀 조건표 고대(가용)인쇄물 Check Sheet Manual 세척 이력 관리 Sheet
6	[이형 Mount]	셀 본딩된 PCB 위에 이형 부품 장착 PCBE 장착된 부품 삽입 상태 검사(AOI)		Multi Mounter AOI	부품	BOM, 도면 확인 자체 고관 Check Mounting 상태 확인 Pick-up 상태 확인	포출검사일지 MES PDA 고대(가용)인쇄물 Check Sheet 부품, Less용 기록표 형상정밀표
6	[Reflow]	PCBE 부착된 부품을 고정하기 위해 접착제를 경화		Reflow/M/C Profile/Jig Push/Pull Gauge	부품	BOM, 도면 확인 자체 고관 Check Mounting 상태 확인 Pick-up 상태 확인 OK,NG Sample로 장비 검증	포출검사일지 MES PDA 고대(가용)인쇄물 Check Sheet 부품, Less용 기록표 AOI 검사 불량 관리 Sheet 형상정밀표
						생산 모델과 프로파일용 일치 할 것, 프로파일 온도 조건표와 프로파일용 일치한다, 회고 온도 : 140도 이하 / 120OverTime:70~100초	저장지로서 냉도 프로파일 형상정밀표 고대(가용)인쇄물 Check Sheet
						Chip 결합 강도 1608 : 1.0gF 이상 2012 : 1.3gF 이상 3216 : 1.5gF 이상	결합 강도 측정 Sheet

* Process Symbols : <V (Incoming), <O (Working Flow Chart), <◇ (Inspection), <□ (Packing), <▷ (Delivery)

Manufacturing Process

4M QC 공정도		작성		검토		승인		
제 / 개 / 장	개정사유	개정No.						
11.09.24	최초제정	0						
관리 No. : 모델명 : PIDF-L101A / PIDK-L102A/PIDF-L103A/PIDK-L104A		품목 : 제조사 : LGT 직장사 :		Method (방법) 제조 장구 요청 리스트 발행 및 출고 관리리스트		작성일 : 11.09.24		
공정번호	공정명	작업내용	MAN (사내)	Machine (장비)	Material (재료)	Method (방법)		
1	[지재준비]	해당 모델의 부품 부피와 수량을 확인하고 Box 하체 후 Tray 에 적치		계측장 부품포장대 이동대차	부품	수량 조정상태, 부분 Lot 상태, 일자 LGT P/N Label 확인		
2	[Manual Insertion]	바코드 라벨 발행		PC Barcode 라벨 프린터 스캐너	라벨	라벨 검증	MES 작업지도서	
3	[수상공정]	PCBA 부품 삽입		수상 장비(이) 납땀자 부품적치대/부품대차 매거진 PC/스캐너	부품 실리콘	납땀 지그 특성표와 PCB 진행 특성표 일치 납땀 부피 확인 부품 삽입 상태 확인 라벨 실크 Box 내 삽입 실리콘 규격 도포 실시	작업지도서 입고 검사 기준서 일상점검표 표준점검서	
4	[Flux공정]	PCB 하단에 Flux 분사		Flux M/C 비중계	Flux	Flux 비중: 0.82340.005 Flux 분포 및 노출 상태 확인	일상점검표	
5	[WaveSoldering 공정]	Soldering		Wave Soldering M/C Solder 자동 공급기 Wave Checker	Solder	Reheat 온도: 110±10°C Pot 1식: 257±3°C Pot 2식: 257±3°C 납조 성분 Check -Cu: 12,000 ppm -Pb: 800ppm 이내 DPU 관리	Soldering 일상 점검 일치 작업지도서 ICP 성분 Data 납조 성분 이력 관리대장 Solder 투입 관리표	
5	[납땀 검사 및 수형 공정]	Soldering 된 제품 납땀 상태 검사 및 수형		인두기 인두 온도 측정기 수형 전대(이)	제품	외관 검사 기준을 참고 하여 전면 검사 실시 인두 온도: 320°C 인두기 누출전압: 10mV 이하	외관 검사 기준서 일상점검표 작업지도서	
6	[ICT 공정]	PCBA 장착된 부품 상태 검사		ICT M/C (AT-01) Fixture PC	제품	모델명, 프로그램 확인 부품 규격 확인	일상점검표 작업지도서 BOM	
7	[동작검사]	제품 동작 검사		Fixture 케이블 Inline 스틱, PC Barcode Scanner	제품	모델명, 공장 확인 Program Version 확인 Check Sum값 확인 (Check sum: 0x8E85C) 제품 전기의 특성 측정 표준 점검표 OK/NG 확인	MES 인두기 수입품 확인 송인용(인기) 특성 Sheet 일상점검표	
8	[내압검사]	제품 내압 검사		Fixture 내압기 Inline 스틱	제품	표준 샘플 OK/NG 확인 내압 검사 실시	송인용(내압 Spec) 일상점검표	
9	[실리콘도포]	실리콘 도포		Dispenser	실리콘	제품별 도포위치	작업지도서 일상점검표	
10	[Aging공정]	제품 Aging 검사		Aging M/C Select Card 유사부하 Cable	제품	온도, 시간 확인 항목 기준 확인	MES 작업지도서 일상점검표	
11	[최종외관검사]	제품 외관 검사			제품	외관 검사 기준을 참고 하여 검사	외관 검사 기준서 작업지도서	
12	[특성검사]	제품 특성 검사		Fixture 계측기 Inline 스틱, PC Barcode Scanner	제품	모델명, 공장 확인 Program Version 확인 제품 전기의 특성 측정 표준 점검표 OK/NG 확인	MES Program 자동 확인 송인용(인기) 특성 Sheet 일상점검표	
13	[포장]	제품 포장		Barcode Scanner PC	제품 Box 에어비닐	모델명, Barcode 확인	MES 작업지도서	

* Process Symbols : ▽(Incoming), ○ (Working Flow Chart), ◇ (Inspection), □ (Packing), ▷ (Delivery)

※ APPENDIX LIST

No.	Contents
1	Power Check List
2	WARRENTY LETTER (RoHS)

POWER CHECK LIST

WARRANTY LETTER

비사용 증명서

구분	<input checked="" type="checkbox"/> 승인용 <input type="checkbox"/> 양산용	제출일자	2011 . 12 . 07
----	--	------	----------------

협력회사				
------	--	--	--	--

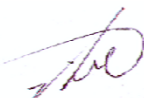
회사명	LG 이노텍	결재	담당자	부서장
연락처	Tel 062-950-0232	성명	김 인 재	김 형 성
e-mail	ijkim@ginnotek.com	서명		

부품정보			
------	--	--	--

LG전자 P/No.	EAY62512701	부품제조일자	
Maker P/No.	PLDF-L101A	생산 공장	LGIT Yantai, Gwangju
부품명(품명)	LGP4247H-12LPB		

당사가 납품하는 납입품 및 당사 제조 공정상 사용되는 물질이 아래 Check 항목에 대해 만족함을 증명합니다.

————— 아 래 —————

ROHS 규제 6대 물질(Pb, Cd, Cr⁶⁺, Hg, PBBs, PBDEs)이 LG전자 Display 사업부 기준을 만족함

※ 아래 항목은 PCB(Printed Circuit Board)에 장착되는 부품일 경우 기록 요망

Soldering Type : Flow Reflow

최대 내열성 온도 : 260 °C 최대 내열성 시간 : 10 sec.

Pb-Free Soldering (Solder Cream, Bar, Wire 모두 포함) 적용이 가능함

Note.

1. 본 자료 상의 모든 기재 내용은 사실에 근거하여 작성하여야 하며, LG전자가 근거 자료를 요구 시, 관련 Data를 제출하여야 한다.
2. 본 자료가 승인용으로 사용될 경우 Sample과 함께 제출하고, 양산용으로 사용될 경우 초품 입고시 제출하여야 한다.
3. LG 전자 Display 사업부에 공급되는 PCB 장착 부품의 내열 기준은 다음과 같음.
Flow 부품 : 260°C/10 sec , Reflow 부품 : 250°C/10 sec