



North/Latin America
Europe/Africa
Asia/Oceania

Internal Use Only

<http://aic.lgservice.com>
<http://eic.lgservice.com>
<http://biz.lgservice.com>

LED LCD TV

SERVICE MANUAL

CHASSIS : LD01S

MODEL : 22LV2300 22LV2300-ZA

CAUTION

BEFORE SERVICING THE CHASSIS,
READ THE SAFETY PRECAUTIONS IN THIS MANUAL.

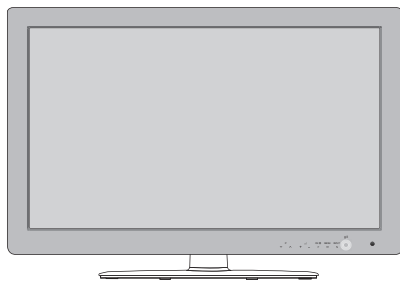

P/NO : MFL67002110 (1106-REV00)

Printed in Korea

CONTENTS

CONTENTS	2
PRODUCT SAFETY	3
SPECIFICATION	6
ADJUSTMENT INSTRUCTION	9
BLOCK DIAGRAM.....	15
EXPLODED VIEW	16
SCHEMATIC CIRCUIT DIAGRAM	

SAFETY PRECAUTIONS

IMPORTANT SAFETY NOTICE

Many electrical and mechanical parts in this chassis have special safety-related characteristics. These parts are identified by \triangle in the Schematic Diagram and Exploded View.

It is essential that these special safety parts should be replaced with the same components as recommended in this manual to prevent Shock, Fire, or other Hazards.

Do not modify the original design without permission of manufacturer.

General Guidance

An **isolation Transformer should always be used** during the servicing of a receiver whose chassis is not isolated from the AC power line. Use a transformer of adequate power rating as this protects the technician from accidents resulting in personal injury from electrical shocks.

It will also protect the receiver and its components from being damaged by accidental shorts of the circuitry that may be inadvertently introduced during the service operation.

If any fuse (or Fusible Resistor) in this TV receiver is blown, replace it with the specified.

When replacing a high wattage resistor (Oxide Metal Film Resistor, over 1 W), keep the resistor 10 mm away from PCB.

Keep wires away from high voltage or high temperature parts.

Before returning the receiver to the customer,

always perform an **AC leakage current check** on the exposed metallic parts of the cabinet, such as antennas, terminals, etc., to be sure the set is safe to operate without damage of electrical shock.

Leakage Current Cold Check(Antenna Cold Check)

With the instrument AC plug removed from AC source, connect an electrical jumper across the two AC plug prongs. Place the AC switch in the on position, connect one lead of ohm-meter to the AC plug prongs tied together and touch other ohm-meter lead in turn to each exposed metallic parts such as antenna terminals, phone jacks, etc.

If the exposed metallic part has a return path to the chassis, the measured resistance should be between 1 M Ω and 5.2 M Ω .

When the exposed metal has no return path to the chassis the reading must be infinite.

An other abnormality exists that must be corrected before the receiver is returned to the customer.

Leakage Current Hot Check (See below Figure)

Plug the AC cord directly into the AC outlet.

Do not use a line Isolation Transformer during this check.

Connect 1.5 K / 10 watt resistor in parallel with a 0.15 uF capacitor between a known good earth ground (Water Pipe, Conduit, etc.) and the exposed metallic parts.

Measure the AC voltage across the resistor using AC voltmeter with 1000 ohms/volt or more sensitivity.

Reverse plug the AC cord into the AC outlet and repeat AC voltage measurements for each exposed metallic part. Any voltage measured must not exceed 0.75 volt RMS which corresponds to 0.5 mA.

In case any measurement is out of the limits specified, there is possibility of shock hazard and the set must be checked and repaired before it is returned to the customer.

Leakage Current Hot Check circuit

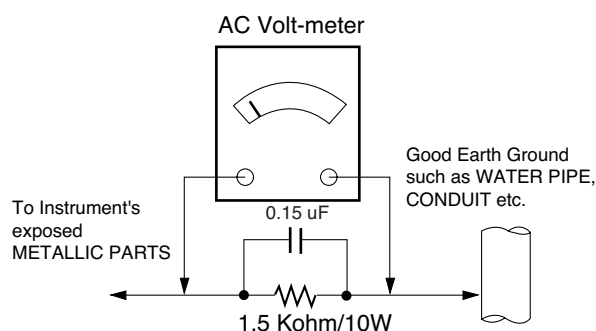

When 25A is impressed between Earth and 2nd Ground for 1 second, Resistance must be less than 0.1 Ω

*Base on Adjustment standard

SERVICING PRECAUTIONS

CAUTION: Before servicing receivers covered by this service manual and its supplements and addenda, read and follow the SAFETY PRECAUTIONS on page 3 of this publication.

NOTE: If unforeseen circumstances create conflict between the following servicing precautions and any of the safety precautions on page 3 of this publication, always follow the safety precautions. Remember: Safety First.

General Servicing Precautions

1. Always unplug the receiver AC power cord from the AC power source before;
 - a. Removing or reinstalling any component, circuit board module or any other receiver assembly.
 - b. Disconnecting or reconnecting any receiver electrical plug or other electrical connection.
 - c. Connecting a test substitute in parallel with an electrolytic capacitor in the receiver.
CAUTION: A wrong part substitution or incorrect polarity installation of electrolytic capacitors may result in an explosion hazard.
2. Test high voltage only by measuring it with an appropriate high voltage meter or other voltage measuring device (DVM, FETVOM, etc) equipped with a suitable high voltage probe. Do not test high voltage by "drawing an arc".
3. Do not spray chemicals on or near this receiver or any of its assemblies.
4. Unless specified otherwise in this service manual, clean electrical contacts only by applying the following mixture to the contacts with a pipe cleaner, cotton-tipped stick or comparable non-abrasive applicator; 10 % (by volume) Acetone and 90 % (by volume) isopropyl alcohol (90 % - 99 % strength)
CAUTION: This is a flammable mixture.
Unless specified otherwise in this service manual, lubrication of contacts is not required.
5. Do not defeat any plug/socket B+ voltage interlocks with which receivers covered by this service manual might be equipped.
6. Do not apply AC power to this instrument and/or any of its electrical assemblies unless all solid-state device heat sinks are correctly installed.
7. Always connect the test receiver ground lead to the receiver chassis ground before connecting the test receiver positive lead.
Always remove the test receiver ground lead last.
8. Use with this receiver only the test fixtures specified in this service manual.
CAUTION: Do not connect the test fixture ground strap to any heat sink in this receiver.

Electrostatically Sensitive (ES) Devices

Some semiconductor (solid-state) devices can be damaged easily by static electricity. Such components commonly are called Electrostatically Sensitive (ES) Devices. Examples of typical ES devices are integrated circuits and some field-effect transistors and semiconductor "chip" components. The following techniques should be used to help reduce the incidence of component damage caused by static by static electricity.

1. Immediately before handling any semiconductor component or semiconductor-equipped assembly, drain off any electrostatic charge on your body by touching a known earth ground. Alternatively, obtain and wear a commercially available discharging wrist strap device, which should be removed to prevent potential shock reasons prior to applying power to the unit under test.

2. After removing an electrical assembly equipped with ES devices, place the assembly on a conductive surface such as aluminum foil, to prevent electrostatic charge buildup or exposure of the assembly.
3. Use only a grounded-tip soldering iron to solder or unsolder ES devices.
4. Use only an anti-static type solder removal device. Some solder removal devices not classified as "anti-static" can generate electrical charges sufficient to damage ES devices.
5. Do not use freon-propelled chemicals. These can generate electrical charges sufficient to damage ES devices.
6. Do not remove a replacement ES device from its protective package until immediately before you are ready to install it. (Most replacement ES devices are packaged with leads electrically shorted together by conductive foam, aluminum foil or comparable conductive material).
7. Immediately before removing the protective material from the leads of a replacement ES device, touch the protective material to the chassis or circuit assembly into which the device will be installed.
CAUTION: Be sure no power is applied to the chassis or circuit, and observe all other safety precautions.
8. Minimize bodily motions when handling unpackaged replacement ES devices. (Otherwise harmless motion such as the brushing together of your clothes fabric or the lifting of your foot from a carpeted floor can generate static electricity sufficient to damage an ES device.)

General Soldering Guidelines

1. Use a grounded-tip, low-wattage soldering iron and appropriate tip size and shape that will maintain tip temperature within the range or 500 °F to 600 °F.
2. Use an appropriate gauge of RMA resin-core solder composed of 60 parts tin/40 parts lead.
3. Keep the soldering iron tip clean and well tinned.
4. Thoroughly clean the surfaces to be soldered. Use a mall wire-bristle (0.5 inch, or 1.25 cm) brush with a metal handle. Do not use freon-propelled spray-on cleaners.
5. Use the following unsoldering technique
 - a. Allow the soldering iron tip to reach normal temperature. (500 °F to 600 °F)
 - b. Heat the component lead until the solder melts.
 - c. Quickly draw the melted solder with an anti-static, suction-type solder removal device or with solder braid.
CAUTION: Work quickly to avoid overheating the circuit board printed foil.
6. Use the following soldering technique.
 - a. Allow the soldering iron tip to reach a normal temperature (500 °F to 600 °F)
 - b. First, hold the soldering iron tip and solder the strand against the component lead until the solder melts.
 - c. Quickly move the soldering iron tip to the junction of the component lead and the printed circuit foil, and hold it there only until the solder flows onto and around both the component lead and the foil.
CAUTION: Work quickly to avoid overheating the circuit board printed foil.
 - d. Closely inspect the solder area and remove any excess or splashed solder with a small wire-bristle brush.

IC Remove/Replacement

Some chassis circuit boards have slotted holes (oblong) through which the IC leads are inserted and then bent flat against the circuit foil. When holes are the slotted type, the following technique should be used to remove and replace the IC. When working with boards using the familiar round hole, use the standard technique as outlined in paragraphs 5 and 6 above.

Removal

1. Desolder and straighten each IC lead in one operation by gently prying up on the lead with the soldering iron tip as the solder melts.
2. Draw away the melted solder with an anti-static suction-type solder removal device (or with solder braid) before removing the IC.

Replacement

1. Carefully insert the replacement IC in the circuit board.
2. Carefully bend each IC lead against the circuit foil pad and solder it.
3. Clean the soldered areas with a small wire-bristle brush. (It is not necessary to reapply acrylic coating to the areas).

"Small-Signal" Discrete Transistor

Removal/Replacement

1. Remove the defective transistor by clipping its leads as close as possible to the component body.
2. Bend into a "U" shape the end of each of three leads remaining on the circuit board.
3. Bend into a "U" shape the replacement transistor leads.
4. Connect the replacement transistor leads to the corresponding leads extending from the circuit board and crimp the "U" with long nose pliers to insure metal to metal contact then solder each connection.

Power Output, Transistor Device

Removal/Replacement

1. Heat and remove all solder from around the transistor leads.
2. Remove the heat sink mounting screw (if so equipped).
3. Carefully remove the transistor from the heat sink of the circuit board.
4. Insert new transistor in the circuit board.
5. Solder each transistor lead, and clip off excess lead.
6. Replace heat sink.

Diode Removal/Replacement

1. Remove defective diode by clipping its leads as close as possible to diode body.
2. Bend the two remaining leads perpendicular y to the circuit board.
3. Observing diode polarity, wrap each lead of the new diode around the corresponding lead on the circuit board.
4. Securely crimp each connection and solder it.
5. Inspect (on the circuit board copper side) the solder joints of the two "original" leads. If they are not shiny, reheat them and if necessary, apply additional solder.

Fuse and Conventional Resistor

Removal/Replacement

1. Clip each fuse or resistor lead at top of the circuit board hollow stake.
2. Securely crimp the leads of replacement component around notch at stake top.
3. Solder the connections.

CAUTION: Maintain original spacing between the replaced component and adjacent components and the circuit board to prevent excessive component temperatures.

Circuit Board Foil Repair

Excessive heat applied to the copper foil of any printed circuit board will weaken the adhesive that bonds the foil to the circuit board causing the foil to separate from or "lift-off" the board. The following guidelines and procedures should be followed whenever this condition is encountered.

At IC Connections

To repair a defective copper pattern at IC connections use the following procedure to install a jumper wire on the copper pattern side of the circuit board. (Use this technique only on IC connections).

1. Carefully remove the damaged copper pattern with a sharp knife. (Remove only as much copper as absolutely necessary).
2. carefully scratch away the solder resist and acrylic coating (if used) from the end of the remaining copper pattern.
3. Bend a small "U" in one end of a small gauge jumper wire and carefully crimp it around the IC pin. Solder the IC connection.
4. Route the jumper wire along the path of the out-away copper pattern and let it overlap the previously scraped end of the good copper pattern. Solder the overlapped area and clip off any excess jumper wire.

At Other Connections

Use the following technique to repair the defective copper pattern at connections other than IC Pins. This technique involves the installation of a jumper wire on the component side of the circuit board.

1. Remove the defective copper pattern with a sharp knife. Remove at least 1/4 inch of copper, to ensure that a hazardous condition will not exist if the jumper wire opens.
2. Trace along the copper pattern from both sides of the pattern break and locate the nearest component that is directly connected to the affected copper pattern.
3. Connect insulated 20-gauge jumper wire from the lead of the nearest component on one side of the pattern break to the lead of the nearest component on the other side. Carefully crimp and solder the connections.

CAUTION: Be sure the insulated jumper wire is dressed so the it does not touch components or sharp edges.

SPECIFICATION

NOTE : Specifications and others are subject to change without notice for improvement.

1. Application range

This specification is applied to the LCD/ LED LCD TV used LD01S chassis.

2. Requirement for Test

Each part is tested as below without special appointment.

- 1) Temperature: 25 °C ± 5 °C(77 °F ± 9 °F), CST: 40 °C ± 5 °C
- 2) Relative Humidity : 65 % ± 10 %
- 3) Power Voltage
 - : Standard input voltage (AC 100-240 V~, 50 / 60 Hz)
 - * Standard Voltage of each products is marked by models.
- 4) Specification and performance of each parts are followed each drawing and specification by part number in accordance with BOM.
- 5) The receiver must be operated for about 5 minutes prior to the adjustment.

3. Test method

- 1) Performance: LGE TV test method followed
- 2) Demanded other specification
 - Safety: CE, IEC specification
 - EMC:CE, IEC

4. Model General Specification

No.	Item	Specification	Remarks
1	Market	EU(PAL Market-36Countries)	DTV-T/C & Analog Germany, Netherlands, Switzerland, Hungary, Austria, Slovenia, Sweden, Denmark, Finland, Norway, Bulgaria
			DTV-T & Analog UK, France, Spain, Italy, Belgium, Russia, Luxemburg, Greece, Czech, Croatia, Turkey, Morocco, Ireland, Latvia, Estonia, Lithuania, Poland, Portugal, Romania, Ukraine, Slovakia
			Analog Only Kazakhstan, Albania, Bosnia, Serbia
2	Broadcasting system	1) PAL-BG 2) PAL-DK 3) PAL-I/I' 4) SECAM L/L' 5) DVB-T/C/S (ID TV)	
3	Receiving system	Analog : Upper Heterodyne Digital : COFDM, QAM	
4	Scart Jack (1EA)	PAL, SECAM	Scart Jack is Full scart and support RF-OUT(analog & DTV)
5	Video Input RCA(1EA)	PAL, SECAM, NTSC	4System : PAL, SECAM, NTSC, PAL60
6	Component Input(1EA)	Y/Cb/Cr, Y/Pb/Pr	
7	RGB Input	RGB-PC	Analog(D-SUB 15PIN)
8	HDMI Input (3EA)	HDMI1-DTV (DVI)	PC(HDMI version 1.3)
		HDMI2-DTV	Support HDCP
		HDMI3-DTV	
9	Audio Input (3EA)	RGB/DVI Audio, Component, AV	L/R Input
10	SDPIF out (1EA)	SPDIF out	
11	Earphone out (1EA)	Antenna, AV1, AV2, AV3, Component, RGB, HDMI1, HDMI2, HDMI3, HDMI4	
12	USB (1EA)	For SVC (download)	
		DivX	
13	DVB	DVB-T	CI : UK, Finland, Denmark, Norway, Sweden, Russia, Spain, Ireland, Luxemburg, Belgium, Netherland CI+ : France(Canal+), Italy(DGTVi)
		DVB-C	CI : Switzerland, Austria, Slovenia, Hungary, Bulgaria CI+ : Switzerland(UPC,Cablecom), Netherland(Ziggo), Germany(KDG,CWB), Finland(labwise)
		DVB-S	CI+ : Germany(Astra HD+)

5. Component Video Input (Y, Cb/Pb, Cr/Pr)

No.	Specification				Remark
	Resolution	H-freq(kHz)	V-freq(Hz)		
1.	720x480	15.73	60.00	SDTV,DVD 480i	
2.	720x480	15.63	59.94	SDTV,DVD 480i	
3.	720x480	31.47	59.94	480p	
4.	720x480	31.50	60.00	480p	
5.	720x576	15.625	50.00	SDTV,DVD 625 Line	
6.	720x576	31.25	50.00	HDTV 576p	
7.	1280x720	45.00	50.00	HDTV 720p	
8.	1280x720	44.96	59.94	HDTV 720p	
9.	1280x720	45.00	60.00	HDTV 720p	
10.	1920x1080	31.25	50.00	HDTV 1080i	
11.	1920x1080	33.75	60.00	HDTV 1080i	
12.	1920x1080	33.72	59.94	HDTV 1080i	
13.	1920x1080	56.250	50	HDTV 1080p	
14.	1920x1080	67.5	60	HDTV 1080p	

6. RGB (PC)

No.	Specification				Proposed	Remark
	Resolution	H-freq(kHz)	V-freq(Hz)	Pixel Clock(MHz)		
1.	720*400	31.468	70.08	28.321		For only DOS mode
2.	640*480	31.469	59.94	25.17	VESA	Input 848*480 60 Hz, 852*480 60 Hz -> 640*480 60 Hz Display
3.	800*600	37.879	60.31	40.00	VESA	
4.	1024*768	48.363	60.00	65.00	VESA(XGA)	
5.	1280*768	47.78	59.87	79.5	WXGA	
6.	1360*768	47.72	59.8	84.75	WXGA	FHD Model
7.	1366*768	47.56	59.6	84.75	WXGA	WXGA Model
8.	1200*1024	63.901	60.02	100.075	SXGA	FHD model
9.	1280*720	45	60	74.25	720p	DTV Standard
10.	1920*1080	67.5	60	148.5	WUXGA	FHD model

7. HDMI Input

(1) DTV Mode

No.	Resolution	H-freq(kHz)	V-freq.(Hz)	Pixel clock(MHz)	Proposed	Remark
1.	720*480	31.469/31.5	59.94/60	27.00/27.03	SDTV 480P	
2.	720*576	31.25	50	54	SDTV 576P	
3.	1280*720	37.500	50	74.25	HDTV 720P	
4.	1280*720	44.96/45	59.94/60	74.17/74.25	HDTV 720P	
5.	1920*1080	33.72/33.75	59.94/60	74.17/74.25	HDTV 1080I	
6.	1920*1080	28.125	50.00	74.25	HDTV 1080I	
7.	1920*1080	26.97/27	23.97/24	74.17/74.25	HDTV 1080P	
8.	1920*1080	33.716/33.75	29.976 /30.00	74.25	HDTV 1080P	
9.	1920*1080	56.250	50	148.5	HDTV 1080P	
10.	1920*1080	67.43/67.5	59.94/60	148.35/148.50	HDTV 1080P	

(2) PC Mode

No.	Resolution	H-freq(kHz)	V-freq.(Hz)	Pixel clock(MHz)	Proposed	Remark
1.	720*400	31.468	70.08	28.321		HDCP
2.	640*480	31.469	59.94	25.17	VESA	HDCP
3.	800*600	37.879	60.31	40.00	VESA	HDCP
4.	1024*768	48.363	60.00	65.00	VESA(XGA)	HDCP
5.	1280*768	47.78	59.87	79.5	WXGA	HDCP
6.	1360*768	47.72	59.8	84.75	WXGA	HDCP
7.	1280*720	45	60	74.25		HDCP
8.	1280*1024	63.981	60.02	108.875	SXGA	HDCP/FHD model
9.	1920*1080	67.5	60	148.5	WUXGA	HDCP/FHD model

ADJUSTMENT INSTRUCTION

1. Application Range

This specification sheet is applied to all of the LCD/ LED LCD TV with LD01S chassis.

2. Designation

- 1) The adjustment is according to the order which is designated and which must be followed, according to the plan which can be changed only on agreeing.
- 2) Power Adjustment: Free Voltage
- 3) Magnetic Field Condition: Nil.
- 4) Input signal Unit: Product Specification Standard
- 5) Reserve after operation: Above 5 Minutes (Heat Run)
Temperature : at 25 °C ± 5 °C
Relative humidity : 65 % ± 10 %
Input voltage : 220 V, 60 Hz
- 6) Adjustment equipments: Color Analyzer(CA-210 or CA-110), DDC Adjustment Jig equipment, Service remote control.
- 7) Push The "IN STOP" key - For memory initialization.

Case1 : Software version up

1. After downloading S/W by USB, TV set will reboot automatically
2. Push "In-stop" key
3. Push "Power on" key
4. Function inspection
5. After function inspection, Push "In-stop" key.

Case2 : Function check at the assembly line

1. When TV set is entering on the assembly line, Push "In-stop" key at first.
2. Push "Power on" key for turning it on.
-> If you push "Power on" key, TV set will recover channel information by itself.
3. After function inspection, Push "In-stop" key.

3. Main PCB check process

* APC - After Manual-Insult, executing APC

* Boot file Download

- 1) Execute ISP program "Mstar ISP Utility" and then click "Config" tab.

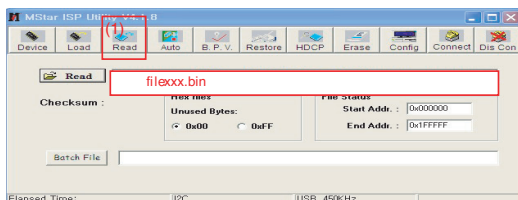

- 2) Set as below, and then click "Auto Detect" and check "OK" message.
If "Error" is displayed, Check connection between computer, jig, and set.
- 3) Click "Read" tab, and then load download file(XXXX.bin) by clicking "Read".
- 4) Click "Connect" tab. If "Can't" is displayed, check connection between computer, jig, and set.

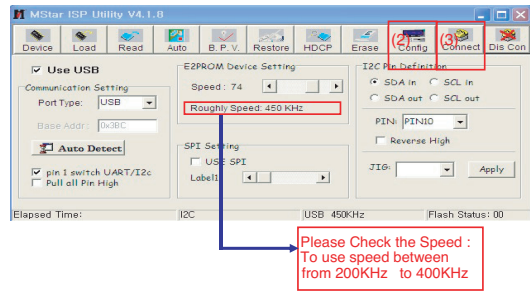

- 5) Click "Auto" tab and set as below.
- 6) Click "Run".
- 7) After downloading, check "OK" message.

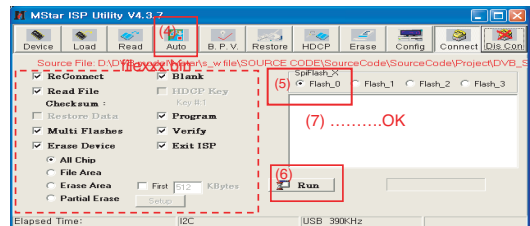

* USB DOWNLOAD

- 1) Put the USB Stick to the USB socket.
- 2) Automatically detecting update file in USB Stick.
- If your downloaded program version in USB Stick is Low, it didn't work. But your downloaded version is High, USB data is automatically detecting
- 3) Show the message "Copying files from memory".

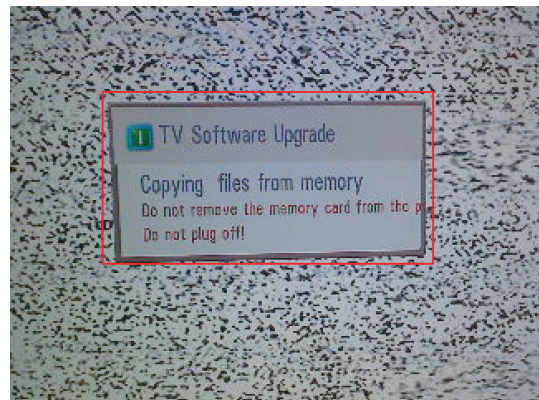

4) Updating is starting.

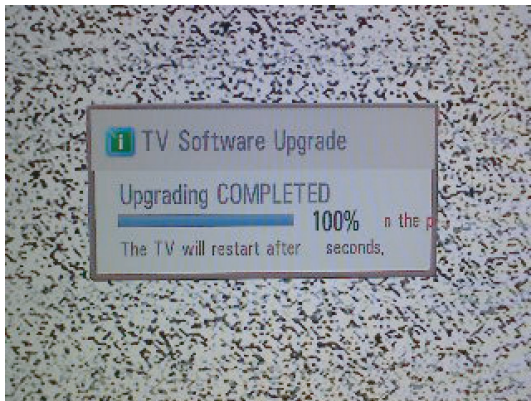
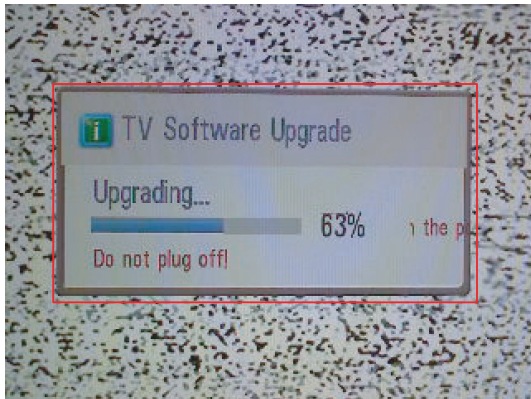

- 5) Uploading completed, the TV will restart automatically.
 6) If your TV is turned on, check your updated version and Tool option.(explain the Tool option, next stage)
 * If downloading version is more high than your TV have, TV can lost all channel data. In this case, you have to channel recover. if all channel data is cleared, you didn't have a DTV/ATV test on production line.

*** After downloading, have to adjust Tool Option again.**

- 1) Push "IN-START" key in service remote control.
- 2) Select "Tool Option 1" and push "OK" key.
- 3) Punch in the number. (Each model has their number)
- 4) Completed selecting Tool option.

3.1. ADC Process

(1) ADC

- Enter Service Mode by pushing "ADJ" key,
- Enter Internal ADC mode by pushing "▶" key at "5. ADC Calibration".

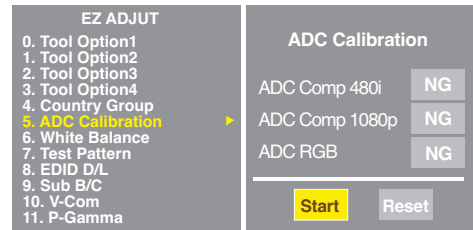

<Caution> Using 'power on' key of the Adjustment remote control, power on TV.

* ADC Calibration Protocol (RS232)

Item	CMD1	CMD2	Data0	
Adjust 'Mode In'	A	A	0 0	When transfer the 'Mode In', Carry the command.
ADC Adjust	A	D	1 0	Automatically adjustment (The use of a internal pattern)

Adjust Sequence

- aa 00 00 [Enter Adjust Mode]
 - xb 00 40 [Component1 Input (480i)]
 - ad 00 10 [Adjust 480i Comp1]
 - xb 00 60 [RGB Input (1024*768)]
 - ad 00 10 [Adjust 1024*768 RGB]
 - aa 00 90 End Adjust mode
- * Required equipment : Adjustment remote control.

3.2. Function Check

- * Check display and sound
- Check Input and Signal items. (cf. work instructions)
 - 1) TV
 - 2) AV (SCART1/SCART2/CVBS)
 - 3) COMPONENT (480i)
 - 4) RGB (PC : 1024 x 768 @ 60 Hz)
 - 5) HDMI
 - 6) PC Audio In
- * Display and Sound check is executed by Remote control.

4. Total Assembly line process

4.1. Adjustment Preparation

- W/B Equipment condition
CA210
- CCFL/EEFL -> CH9, Test signal: Inner pattern(80IRE)
LED -> CH14, Test signal: Inner pattern(80IRE)
- Above 5 minutes H/run in the inner pattern. ("power on" key of adjustment remote control)

Cool	9,300	K	X=0.285(±0.002)	<Test Signal> Inner pattern (204 gray, 80 IRE)
			Y=0.293(±0.002)	
Medium	8,000	K	X=0.295(±0.002)	
			Y=0.305(±0.002)	
Warm	6,500	K	X=0.313(±0.002)	
			Y=0.329(±0.002)	

- Edge LED W/B Table is process of time (Only LGD Module)
CA210: CH14, Test signal : Inner pattern(80IRE)

GP2R	Aging Time (Min.)	Cool		Medium		Warm	
		X	Y	X	Y	X	Y
				269	273	285	293
1	0-2	279	288	295	308	319	338
2	3-5	278	286	294	306	318	336
3	6-9	277	285	293	305	317	335
4	10-19	276	283	292	303	316	333
5	20-35	274	280	290	300	314	330
6	36-49	272	277	288	297	312	327
7	50-79	271	275	287	295	311	325
8	80-149	270	274	286	294	310	324
9	Over 150	269	273	285	293	309	323

- * Connecting picture of the measuring instrument
(On Automatic control)

Inside Pattern is used when W/B is controlled. Connect to auto controller or push Adjustment remote control POWER ON -> Enter the mode of White-Balance, the pattern will come out.

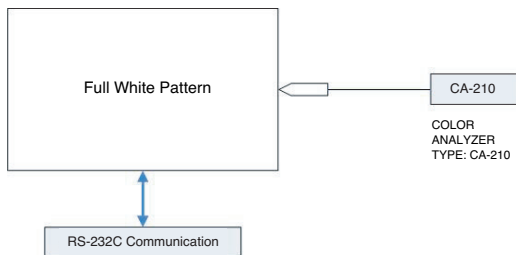

- * Auto-control interface and directions

- 1) Adjust in the place where the influx of light like floodlight around is blocked. (Illumination is less than 10 lux).
- 2) Adhere closely the Color Analyzer (CA210) to the module less than 10 cm distance, keep it with the surface of the Module and Color Analyzer's probe vertically.(80° ~ 100°).
- 3) Aging time
 - After aging start, keep the power on (no suspension of power supply) and heat-run over 5 minutes.
 - Using 'no signal' or 'full white pattern' or the others, check the back light on.

- Auto adjustment Map(RS-232C)

RS-232C COMMAND

[CMD ID DATA]

Wb 00 00

White Balance Start

Wb 00 ff

White Balance End

	RS-232C COMMAND			MIN	CENTER			MAX
	[CMD ID DATA]				(DEFAULT)			
	Cool	Mid	Warm		Cool	Mid	Warm	
R Gain	jh	Ja	jd	00	172	192	192	192
G Gain	jh	Jb	je	00	172	192	192	192
B Gain	ji	Jc	jf	00	192	192	172	192
R Cut					64	64	64	128
G Cut					64	64	64	128
B Cut					64	64	64	128

- ** Caution **

Color Temperature : COOL, Medium, Warm.

One of R Gain/G Gain/ B Gain should be kept on 0xC0, and adjust other two lower than C0.

(when R/G/B Gain are all C0, it is the FULL Dynamic Range of Module)

- * Manual W/B process using adjusts Remote control.

- After enter Service Mode by pushing "ADJ" key,
- Enter White Balance by pushing "▶" key at "6. White Balance".

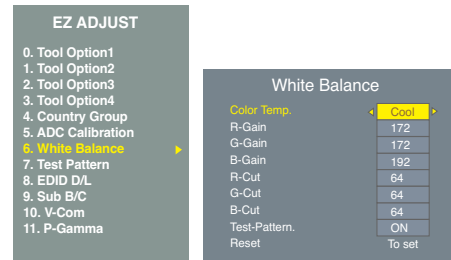

- * After you finished all adjustments, Press "In-start" key and compare Tool option and Area option value with its BOM, if it is correctly same then unplug the AC cable. If it is not same, then correct it same with BOM and unplug AC cable. For correct it to the model's module from factory Jig model.

- * Push the "IN STOP" key after completing the function inspection. And Mechanical Power Switch must be set "ON".

4.2. DDC EDID Write (RGB 128Byte)

- Connect D-sub Signal Cable to D-sub Jack.
- Write EDID Data to EEPROM(24C02) by using DDC2B protocol.
- Check whether written EDID data is correct or not.
- * For Service main Assembly, EDID have to be downloaded to Insert Process in advance.

4.3. DDC EDID Write (HDMI 256Byte)

- Connect HDMI Signal Cable to HDMI Jack.
- Write EDID Data to EEPROM(24C02) by using DDC2B protocol.
- Check whether written EDID data is correct or not.
- * For Service main Assembly, EDID have to be downloaded to Insert Process in advance.

4.4. EDID DATA

- 1) All Data : HEXA Value
- 2) Changeable Data :
- *: Serial No : Controlled / Data:01
- ** : Month : Controlled / Data:00
- ***: Year : Controlled
- ****: Check sum

- Auto Download

- After enter Service Mode by pushing “ADJ” key,
- Enter EDID D/L mode.
- Enter “START” by pushing “OK” key.

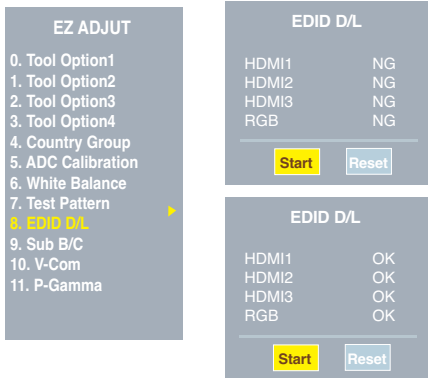

* Caution : Never connect HDMI & D-sub Cable when EDID download.

* Edid data and Model option download (RS232)

Item	CMD1	CMD2	Data0	
Download 'Mode In'	A	A	0 0	When transfer the 'Mode In', Carry the command.
Download	A	E	00 10	Automatically Download (The use of a internal pattern)

- Manual Download

- * Caution
- 1) Use the proper signal cable for EDID Download.
 - Analog EDID : Pin3 exists
 - Digital EDID : Pin3 exists
- 2) Never connect HDMI & D-sub Cable at the same time.
- 3) Use the proper cables below for EDID Writing.
- 4) Download HDMI1, HDMI2, separately because HDMI1 is different from HDMI2.



Item	Condition	Data(Hex)
Manufacturer ID	GSM	1E6D
Version	Digital : 1	01
Revision	Digital : 3	03

1) HD RGB EDID data

	0	1	2	3	4	5	6	7	8	9	A	B	C	D	E	F
00	00	FF	FF	FF	FF	FF	FF	00	1E	6D	a		b			
10	c	01	03	68	10	09	78	0A	EE	91	A3	54	4C	99	26	
20	0F	50	54	A1	08	00	81	C0	61	40	45	40	31	40	01	01
30	01	01	01	01	01	01	1B	21	50	A0	51	00	1E	30	48	88
40	35	00	A0	5A	00	00	00	1C	01	1D	00	72	51	D0	1E	20
50	6E	28	55	00	A0	5A	00	00	00	1E	00	00	00	FD	00	3A
60	3E	1F	46	10	00	0A	20	20	20	20	20	d				
70	d														00	e
80	FF	FF	FF	FF	FF	FF	FF	FF	FF	FF	FF	FF	FF	FF	FF	FF
90	FF	FF	FF	FF	FF	FF	FF	FF	FF	FF	FF	FF	FF	FF	FF	FF
A0	FF	FF	FF	FF	FF	FF	FF	FF	FF	FF	FF	FF	FF	FF	FF	FF
B0	FF	FF	FF	FF	FF	FF	FF	FF	FF	FF	FF	FF	FF	FF	FF	FF
C0	FF	FF	FF	FF	FF	FF	FF	FF	FF	FF	FF	FF	FF	FF	FF	FF
D0	FF	FF	FF	FF	FF	FF	FF	FF	FF	FF	FF	FF	FF	FF	FF	FF
E0	FF	FF	FF	FF	FF	FF	FF	FF	FF	FF	FF	FF	FF	FF	FF	FF
F0	FF	FF	FF	FF	FF	FF	FF	FF	FF	FF	FF	FF	FF	FF	FF	FF

2) HD HDMI EDID data

	0	1	2	3	4	5	6	7	8	9	A	B	C	D	E	F
00	00	FF	FF	FF	FF	FF	FF	00	1E	6D	a		b			
10	c	01	03	80	10	09	78	0A	EE	91	A3	54	4C	99	26	
20	0F	50	54	A1	08	00	81	C0	61	40	45	40	31	40	01	01
30	01	01	01	01	01	01	1B	21	50	A0	51	00	1E	30	48	88
40	35	00	A0	5A	00	00	00	1C	01	1D	00	72	51	D0	1E	20
50	6E	28	55	00	A0	5A	00	00	00	1E	00	00	00	FD	00	3A
60	3E	1F	46	10	00	0A	20	20	20	20	20	d				
70	d														01	e
80	02	03	20	F1	4E	10	1F	84	13	05	14	03	02	12	20	21
90	22	15	01	26	15	07	50	09	57	07	f					
A0	f	80	18	71	1C	16	20	58	2C	25	00	A0	5A	00	00	
B0	00	9E	01	1D	00	80	51	D0	0C	20	40	80	35	00	A0	5A
C0	00	00	00	1E	8C	0A	D0	8A	20	E0	2D	10	10	3E	96	00
D0	A0	5A	00	00	00	18	02	3A	80	18	71	38	2D	40	58	2C
E0	45	00	A0	5A	00	00	00	1E	01	1D	80	D0	72	1C	16	20
F0	10	2C	25	80	A0	5A	00	00	00	9E	00	00	00	00	00	0e

* Detail EDID Options are below
Product ID

Model Name	HEX	EDID Table	DDC Function
HD Model	0000	00 00	Analog/Digital

Serial No: Controlled on production line.
 Month, Year: Week : '01' -> '01'
 Year : '2011' -> '15' fix

Model Name(Hex):

MODEL	MODEL NAME(HEX)
all	00 00 00 FC 00 4C 47 20 54 56 0A 20 20 20 20 20 20

Checksum: Changeable by total EDID data.
 Vendor Specific(HDMI)

INPUT	MODEL NAME(HEX)
HDMI1	65030C001000
HDMI2	65030C002000
HDMI3	65030C003000

4.5. V-COM Adjust(Only LGD(M+S) Module)

- Why need Vcom adjustment?
- The Vcom (Common Voltage) is a Reference Voltage of Liquid Crystal Driving.
- > Liquid Crystal need for Polarity Change with every frame.

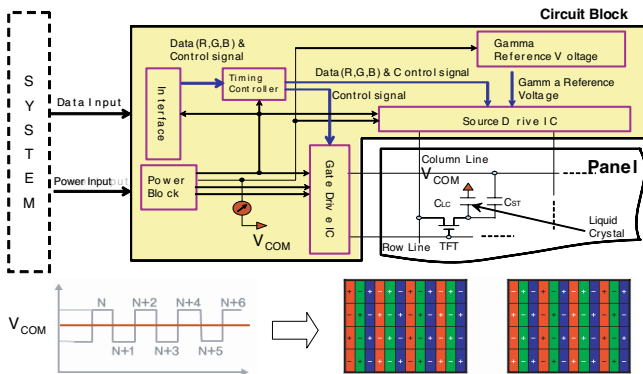

- Adjust sequence
- Press the PIP key of the ADJ remote control. (This PIP key is hot key to enter the VCOM adjusting mode) (Or After enter Service Mode by pushing "ADJ" key, then Enter V-Com Adjust mode by pushing "▶" key at "10. V-Com".)
- As pushing the right or the left key on the remote control, and find the V-COM value which is no or minimized the Flicker. (If there is no flicker at default value, Press the exit key and finish the VCOM adjustment.)
- Push the "OK" key to store value. Then the message "Saving OK" is pop.
- Press the exit key to finish VCOM adjustment.



(Visual Adjust and control the Voltage level)

4.6. Outgoing condition Configuration

When pressing IN-STOP key by Service remote control, Red LED are blinked alternatively. And then Automatically turn off. (Must not AC power OFF during blinking)

4.7. Hi-pot Test

Confirm whether is normal or not when between power board's ac block and GND is impacted on 1.5 kV(dc) or 2.2 kV(dc) for one second.

5. Model name & Serial number D/L

- Press "Power on" key of service remote control. (Baud rate : 115200 bps)
- Connect RS232 Signal Cable to RS-232 Jack.
- Write Serial number by use RS-232.
- Must check the serial number at the Diagnostics of SET UP menu. (Refer to below.)

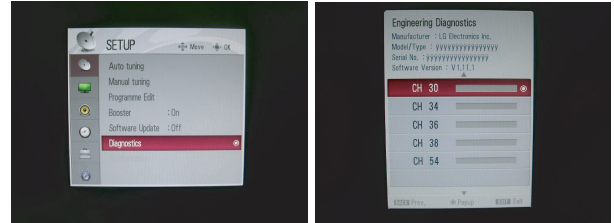

5.1. Signal TABLE

CMD	LENGTH	ADH	ADL	DATA_1	...	Data_n	CS	DELAY
-----	--------	-----	-----	--------	-----	--------	----	-------

CMD : A0h
 LENGTH : 85~94h (1~16 bytes)
 ADH : EEPROM Sub Address high (00~1F)
 ADL : EEPROM Sub Address low (00~FF)
 Data : Write data
 CS : CMD + LENGTH + ADH + ADL + Data_1 +...+ Data_n
 Delay : 20ms

5.2. Command Set

No.	Adjust mode	CMD(hex)	LENGTH(hex)	Description
1	EEPROM WRITE	A0h	84h+n	n-bytes Write(n=1~16)

* Description
 FOS Default write : <7mode data> write
 Vtotal, V_Frequency, Sync_Polarity, Htotal, Hstart, Vstart, 0, Phase
 Data write : Model Name and Serial Number write in EEPROM,.

5.3. Method & notice

- Serial number D/L is using of scan equipment.
- Setting of scan equipment operated by Manufacturing Technology Group.
- Serial number D/L must be conformed when it is produced in production line, because serial number D/L is mandatory by D-book 4.0.

* Manual Download (Model Name and Serial Number)
 If the TV set is downloaded by OTA or Service man, Sometimes model name or serial number is initialized.(Not always)
 There is impossible to download by bar code scan, so It need Manual download.

- 1) Press the "Instart" key of Adjustment remote control.
- 2) Go to the menu '5.Model Number D/L' like below photo.
- 3) Input the Factory model name(ex 42LD450-ZA) or Serial number like photo.

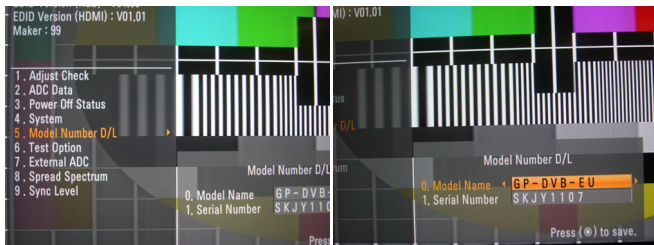

- 4) Check the model name Instart menu. -> Factory name displayed. (ex 42LD450-ZA)
- 5) Check the Diagnostics. (DTV country only) -> Buyer model displayed. (ex 42LD450)

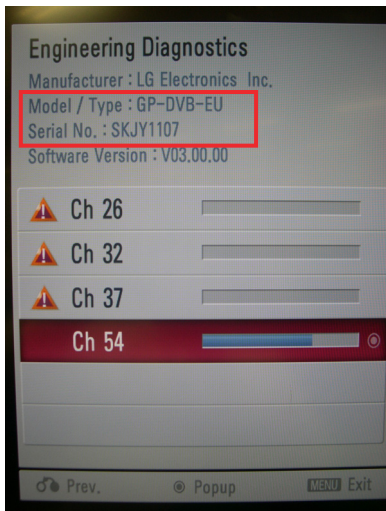

6. CI+ Key Download method

- (1) Download Procedure
 - 1) Press "Power on" key of a service remote control. (Baud rate : 115200 bps)
 - 2) Connect RS232-C Signal Cable.
 - 3) Write CI+ Key through RS-232-C.
 - 4) Check whether the key was downloaded or not at 'In Start' menu. (Refer to below.)



=> Check the Download to CI+ Key value in LGset.

1. Check the method of CI+ Key value.
 - a. Check the method on Instart menu.
 - b. Check the method of RS232C Command.
 - 1) Into the main assembly mode (RS232 : aa 00 00)

CMD 1	CMD 2	Data 0
A	A	0 0

- 2) Check the key download for transmitted command. (RS232 : ci 00 10)

CMD 1	CMD 2	Data 0
C	I	1 0

- 3) Result value
 - Normally status for download : OKx
 - Abnormally status for download : NGx

2. Check the method of CI+ Key value. (RS232)
 - 1) Into the main assembly mode (RS232 : aa 00 00)

CMD 1	CMD 2	Data 0
A	A	0 0

- 2) Check the method of CI+ key by command. (RS232 : ci 00 20)

CMD 1	CMD 2	Data 0
C	I	2 0

- 3) Result value

i 01 OK 1d1852d21c1ed5dcx

└──────────────────┬──────────────────> CI+ key Value

7. Local Dimming Function Check

- Step1) Turn on TV.
- Step2) Press "P-only" key, entrance to power only mode and Press "Exit" key.
- Step3) Press "Tilt" key, entrance to Local Dimming mode.
- Step4) At the Local Dimming mode, module Edge Backlight moving right to left Back light of module moving.
- Step5) Confirm the Local Dimming mode.
- Step6) Press "Exit" key.

BLOCK DIAGRAM

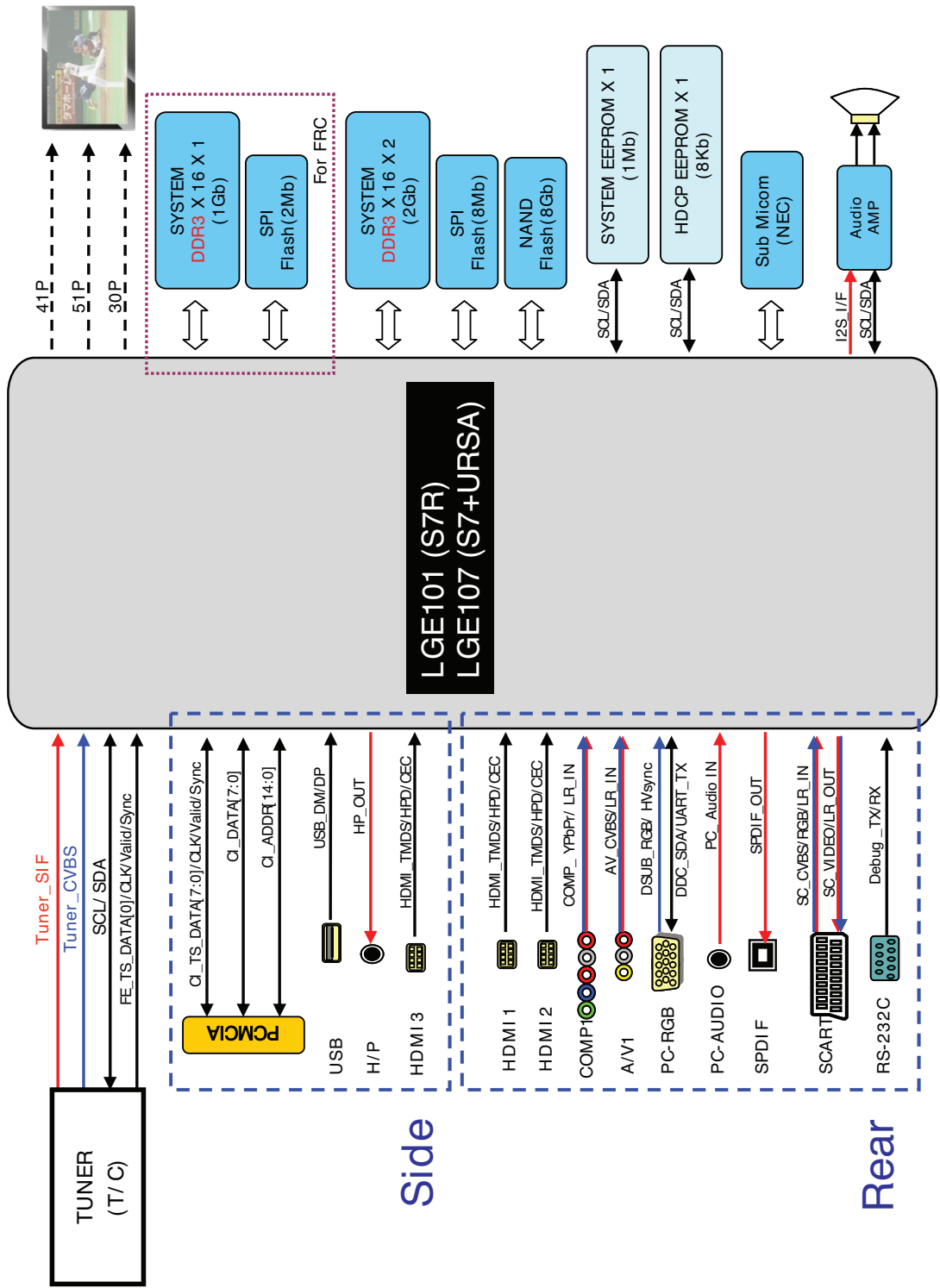

EXPLODED VIEW

IMPORTANT SAFETY NOTICE

Many electrical and mechanical parts in this chassis have special safety-related characteristics. These parts are identified by Δ in the Schematic Diagram and EXPLODED VIEW. It is essential that these special safety parts should be replaced with the same components as recommended in this manual to prevent X-RADIATION, Shock, Fire, or other Hazards. Do not modify the original design without permission of manufacturer.

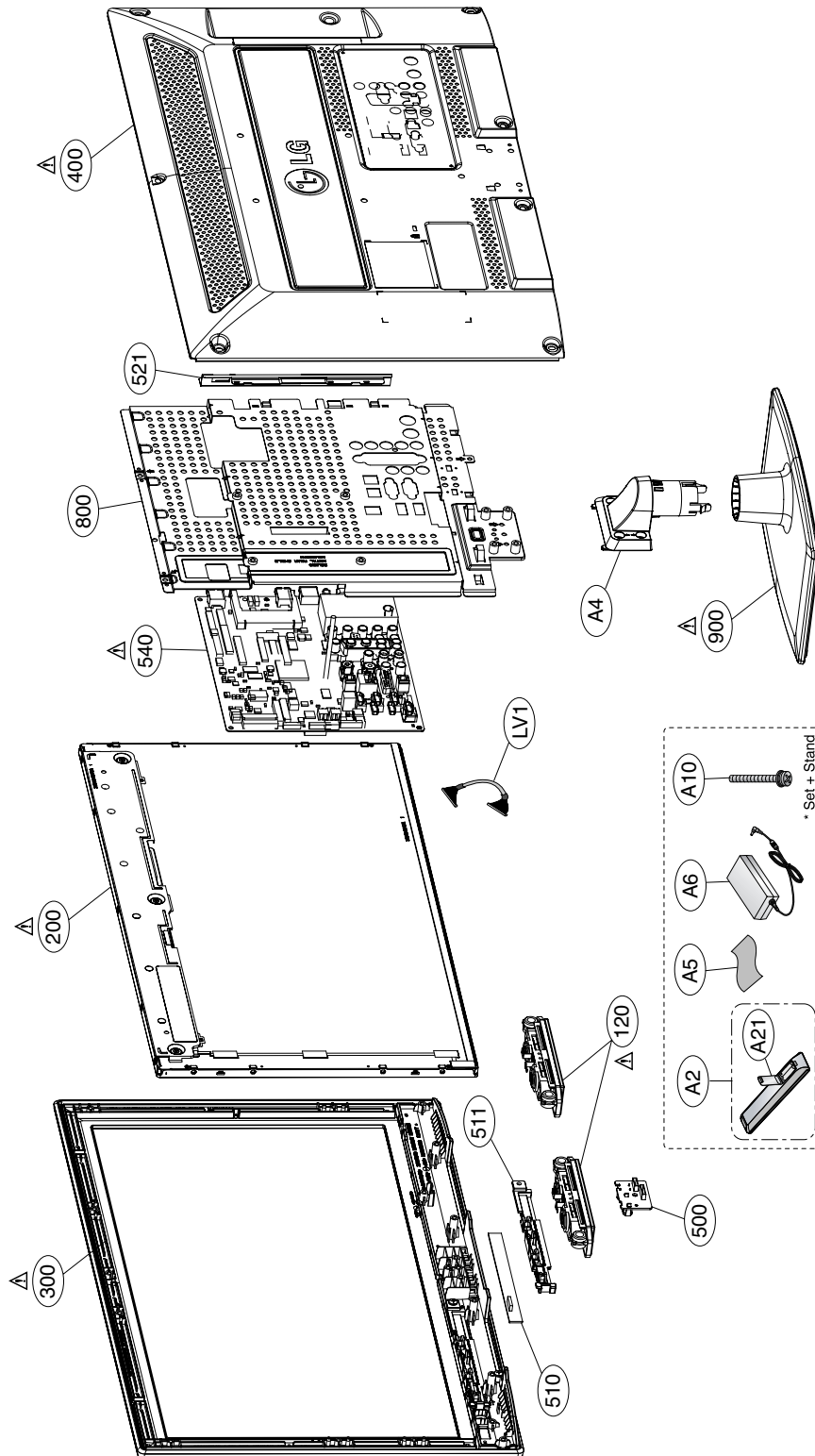

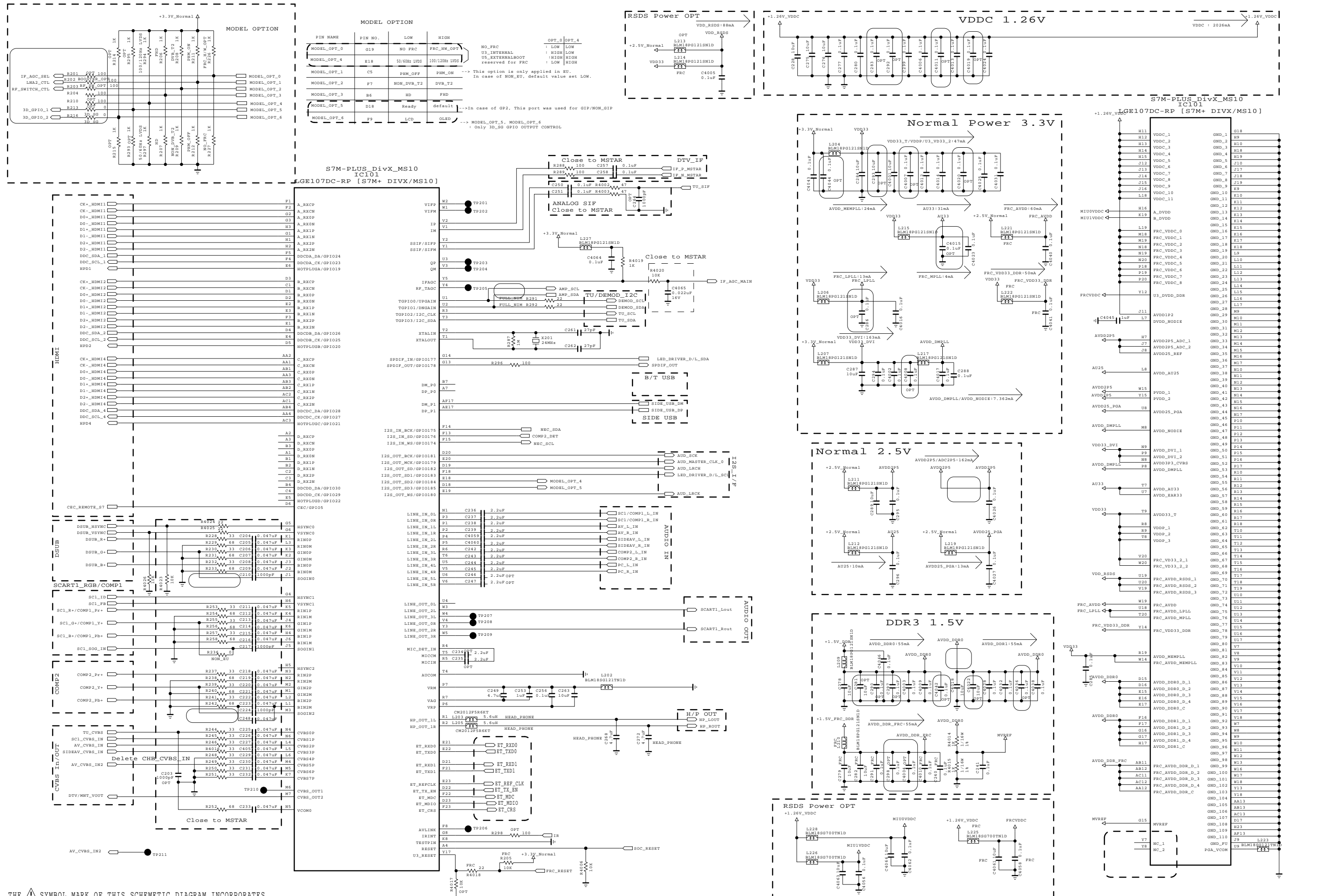

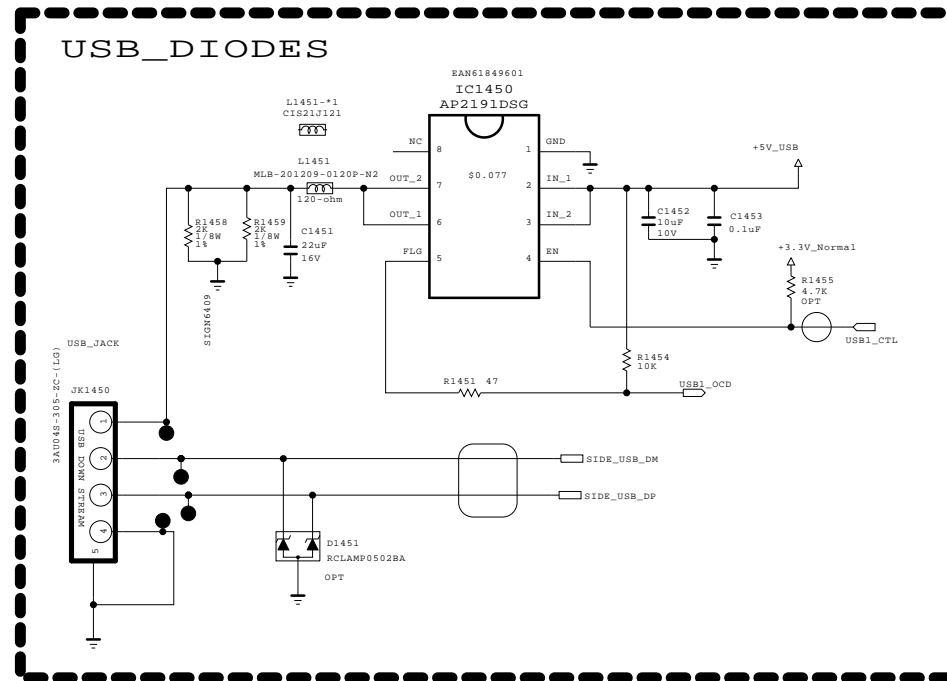

THE SYMBOL MARK OF THIS SCHEMATIC DIAGRAM INCORPORATES SPECIAL FEATURES IMPORTANT FOR PROTECTION FROM X-RADIATION. FILRE AND ELECTRICAL SHOCK HAZARDS, WHEN SERVICING IF IS ESSENTIAL THAT ONLY MANUFACTURES SPECIFIED PARTS BE USED FOR THE CRITICAL COMPONENTS IN THE SYMBOL MARK OF THE SCHEMATIC.

SECRET
LGElectronics



MODEL	GP2R	DATE	20101023
BLOCK	USB_OCP_DIODE	SHEET	7 /

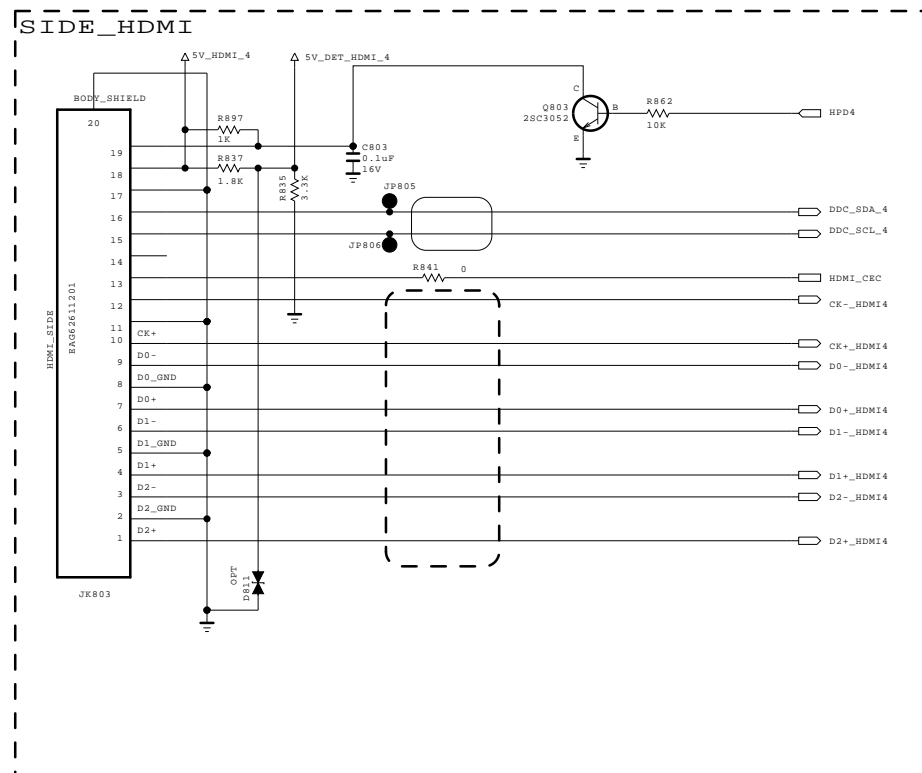
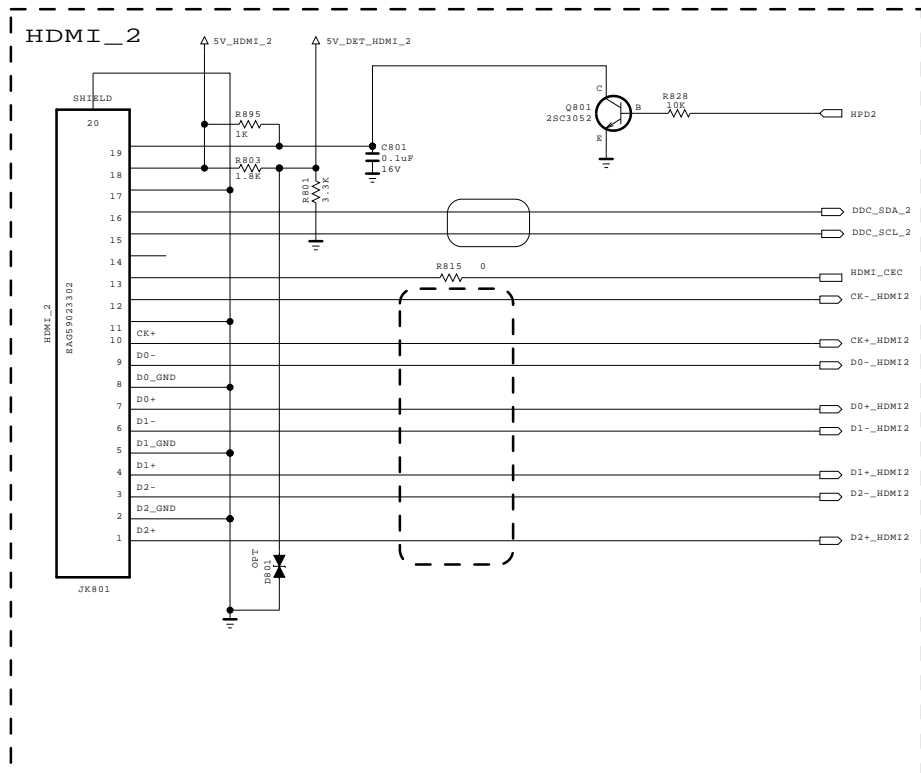
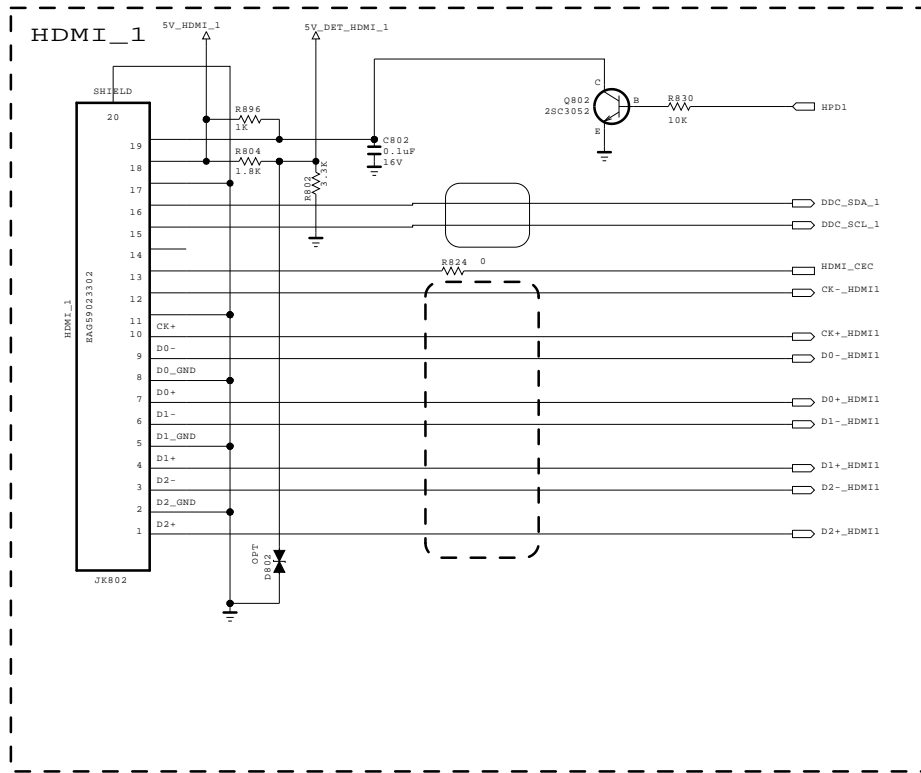

HDMI EEPROM

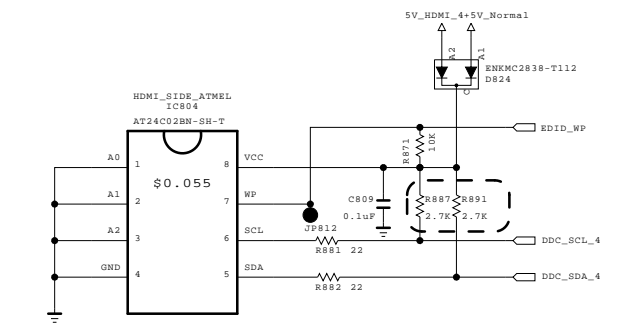
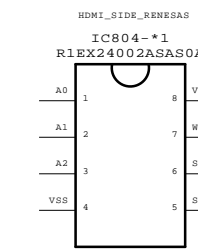
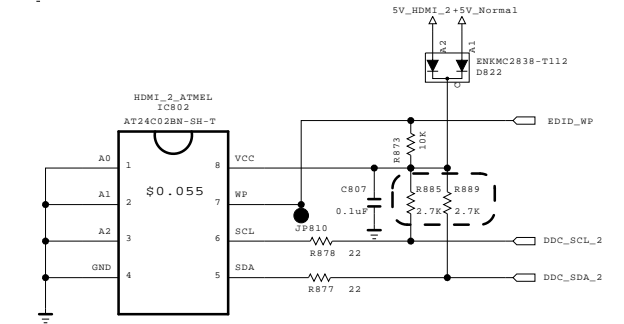
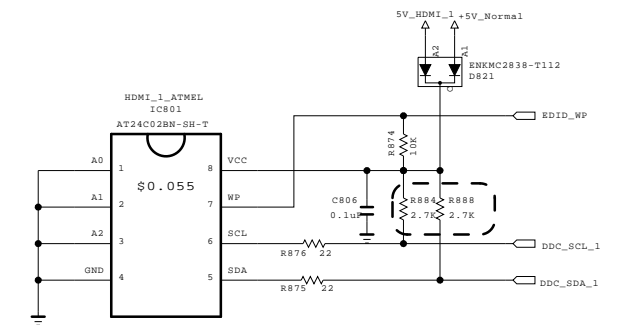
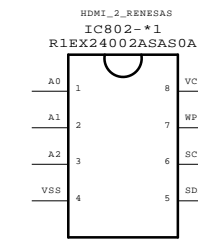
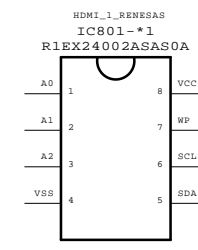

For CEC

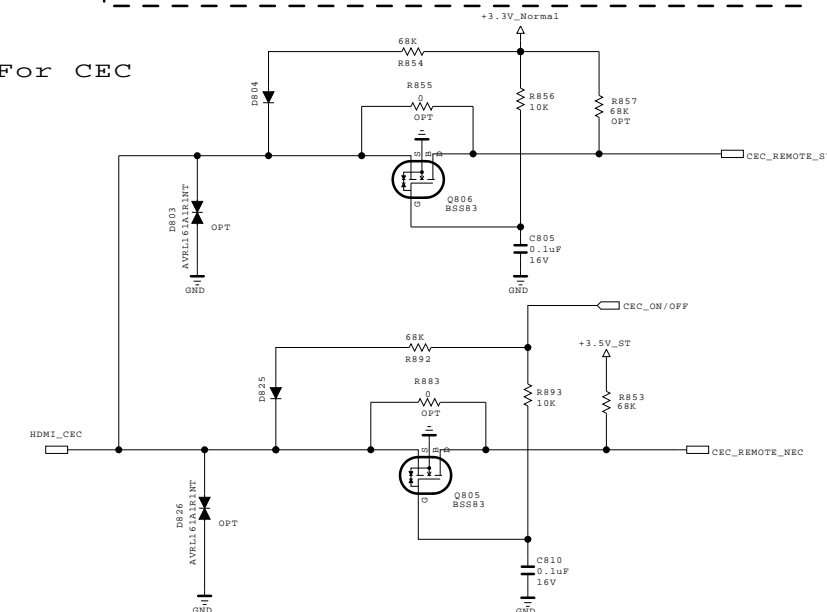

THE SYMBOL MARK OF THIS SCHEMATIC DIAGRAM INCORPORATES SPECIAL FEATURES IMPORTANT FOR PROTECTION FROM X-RADIATION. FILRE AND ELECTRICAL SHOCK HAZARDS, WHEN SERVICING IF IS ESSENTIAL THAT ONLY MANUFACTURES SPECIFIED PARTS BE USED FOR THE CRITICAL COMPONENTS IN THE SYMBOL MARK OF THE SCHEMATIC.

SECRET
LGElectronics



MODEL	GP2R	DATE	20101023
BLOCK	HDMI	SHEET	8

RGB / SPDIF / PC / HP

New Item Development EARPHONE BLOCK

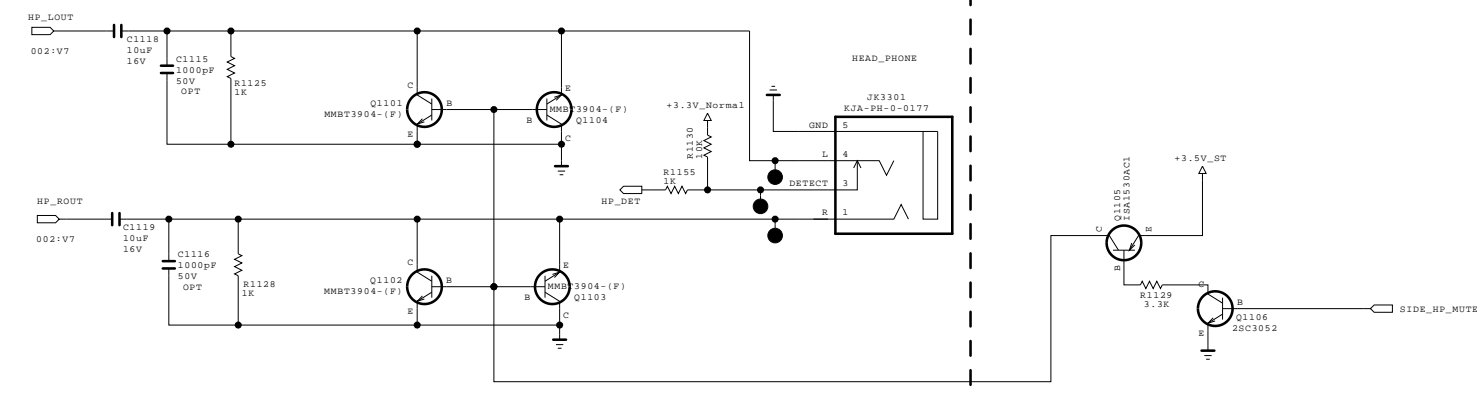

PC AUDIO

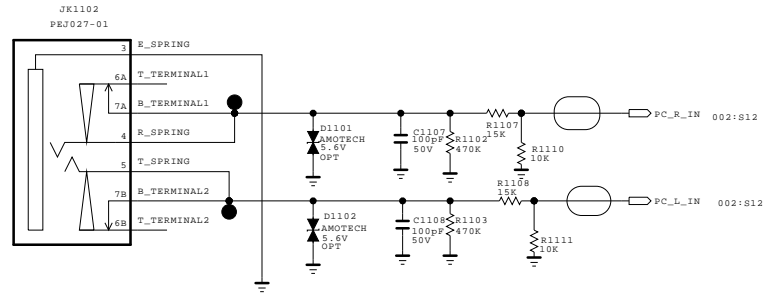

SPDIF OPTIC JACK

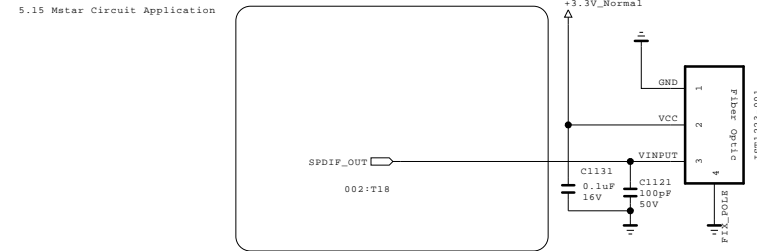

RGB PC

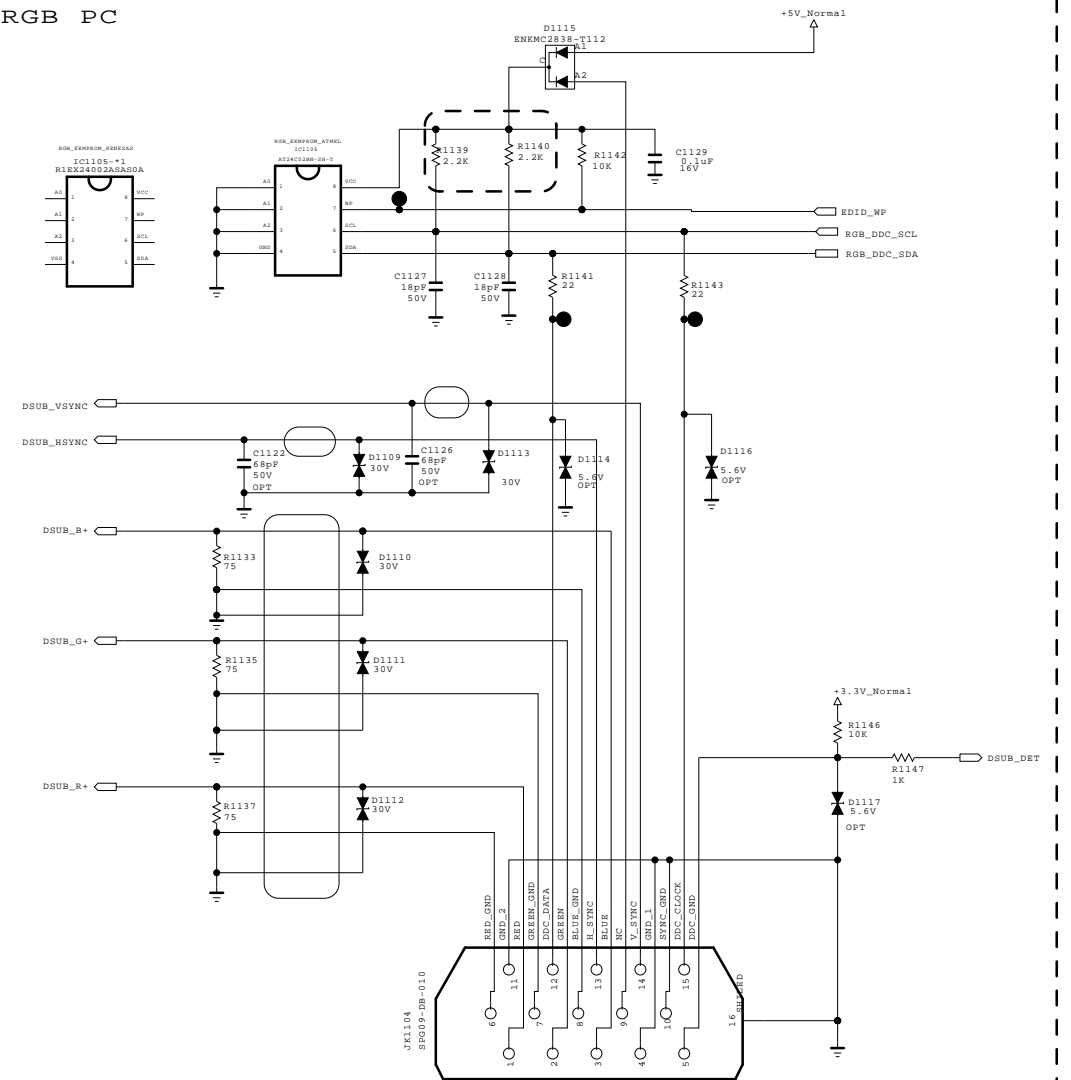

THE SYMBOL MARK OF THIS SCHEMATIC DIAGRAM INCORPORATES SPECIAL FEATURES IMPORTANT FOR PROTECTION FROM X-RADIATION. FILRE AND ELECTRICAL SHOCK HAZARDS, WHEN SERVICING IF IS ESSENTIAL THAT ONLY MANUFACTURES SPECIFIED PARTS BE USED FOR THE CRITICAL COMPONENTS IN THE SYMBOL MARK OF THE SCHEMATIC.

SECRET
LGElectronics



MODEL	GP2R	DATE	20101023
BLOCK	RGB / SPDIF / HP	SHEET	9 /

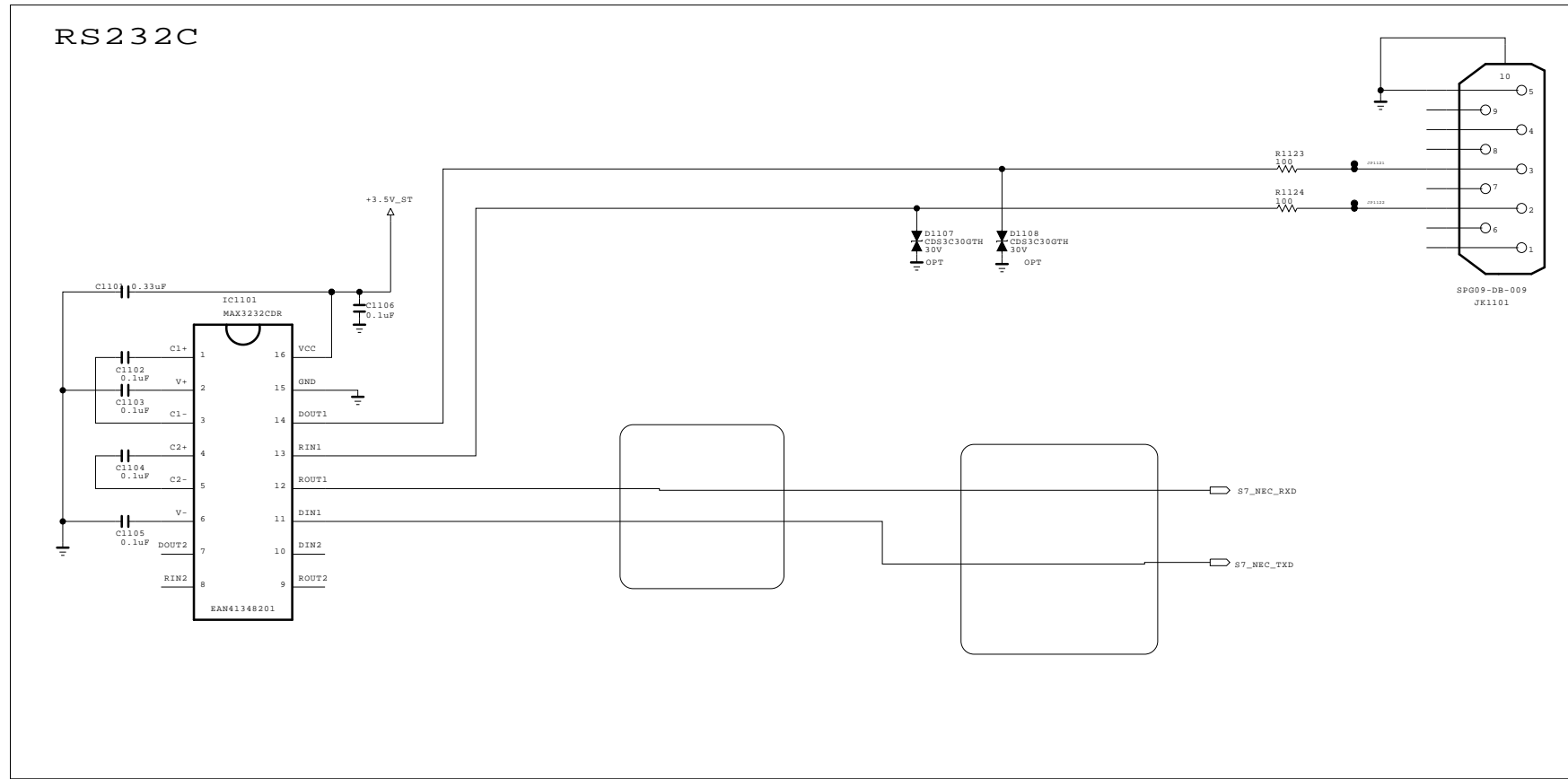

THE SYMBOL MARK OF THIS SCHEMATIC DIAGRAM INCORPORATES SPECIAL FEATURES IMPORTANT FOR PROTECTION FROM X-RADIATION. FILRE AND ELECTRICAL SHOCK HAZARDS, WHEN SERVICING IF IS ESSENTIAL THAT ONLY MANUFACTURES SPECIFIED PARTS BE USED FOR THE CRITICAL COMPONENTS IN THE SYMBOL MARK OF THE SCHEMATIC.

SECRET
LGElectronics



MODEL	GP2R	DATE	20101023
BLOCK	RS232C_9PIN	SHEET	10 /

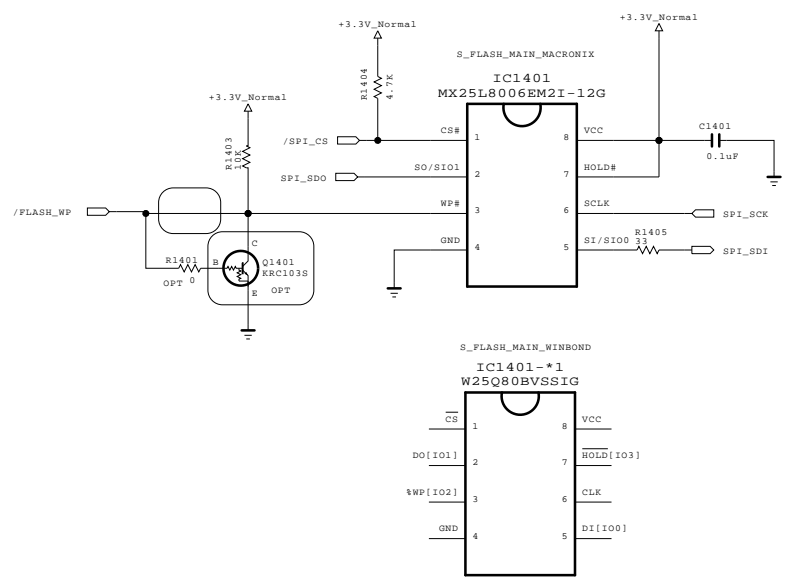

THE SYMBOL MARK OF THIS SCHEMATIC DIAGRAM INCORPORATES SPECIAL FEATURES IMPORTANT FOR PROTECTION FROM X-RADIATION. FILRE AND ELECTRICAL SHOCK HAZARDS, WHEN SERVICING IF IS ESSENTIAL THAT ONLY MANUFACTURES SPECIFIED PARTS BE USED FOR THE CRITICAL COMPONENTS IN THE SYMBOL MARK OF THE SCHEMATIC.

SECRET
LGElectronics



MODEL	GP2R	DATE	20101023
BLOCK	SFLASH 1MB	SHEET	13 /

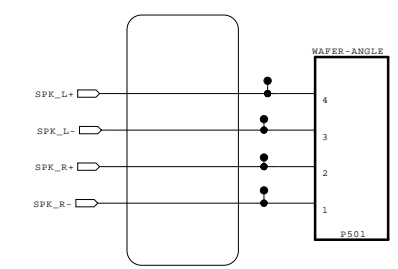
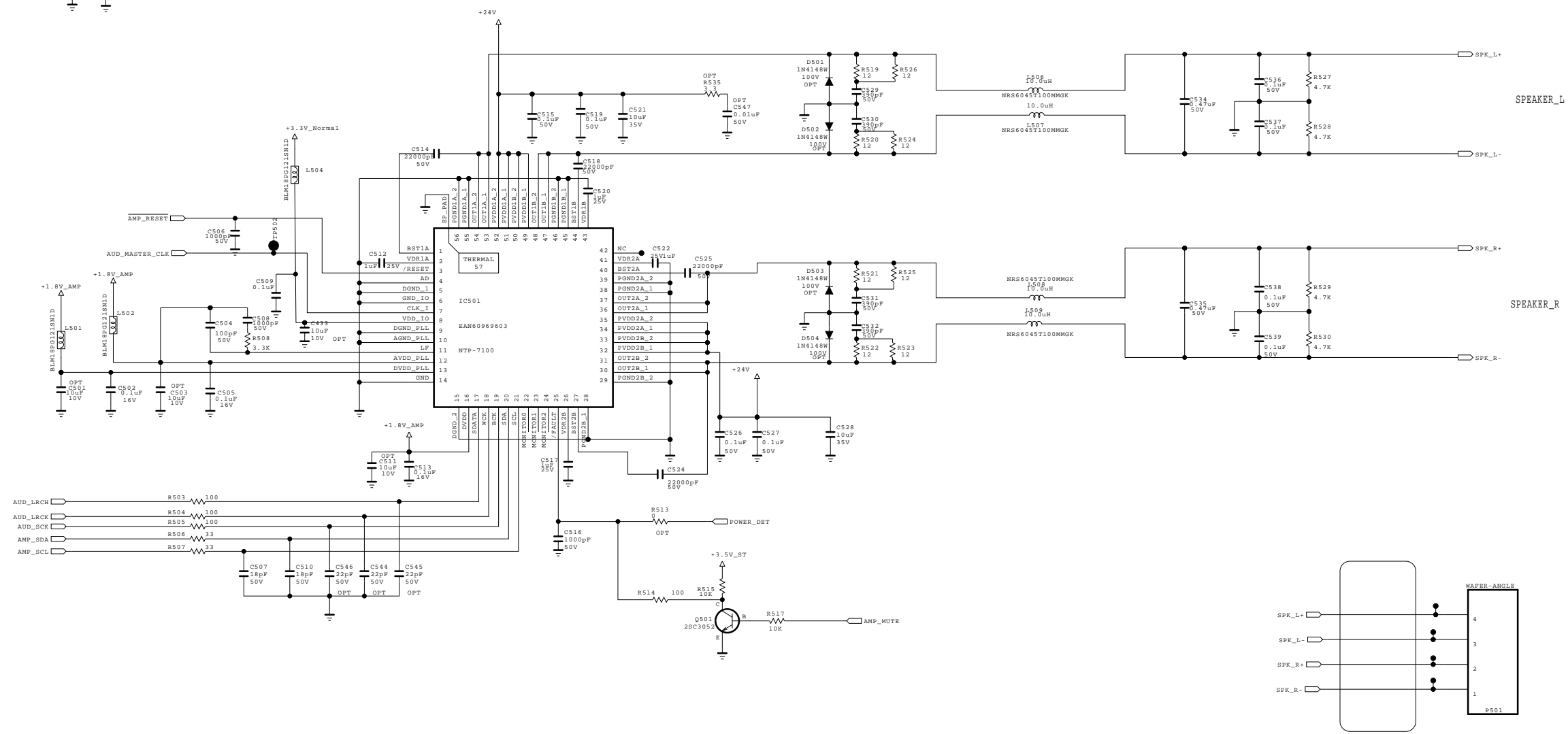
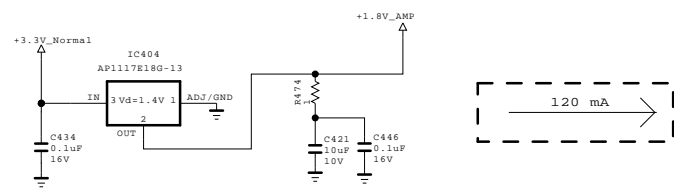

THE SYMBOL MARK OF THIS SCHEMATIC DIAGRAM INCORPORATES SPECIAL FEATURES IMPORTANT FOR PROTECTION FROM X-RADIATION. FILRE AND ELECTRICAL SHOCK HAZARDS, WHEN SERVICING IF IS ESSENTIAL THAT ONLY MANUFACTURES SPECIFIED PARTS BE USED FOR THE CRITICAL COMPONENTS IN THE SYMBOL MARK OF THE SCHEMATIC.

SECRET
LGElectronics



MODEL	GP2R	DATE	20101023
BLOCK	AMP NTP	SHEET	16 /

Rear AV

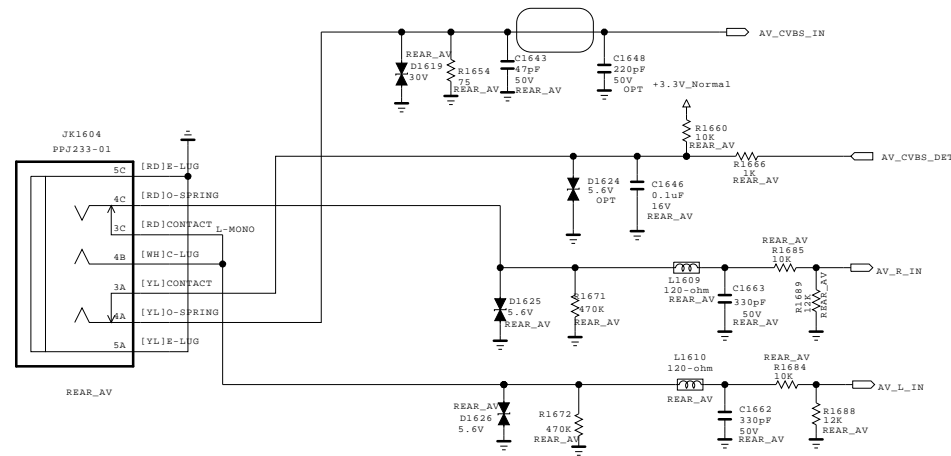

COMPONENT 2

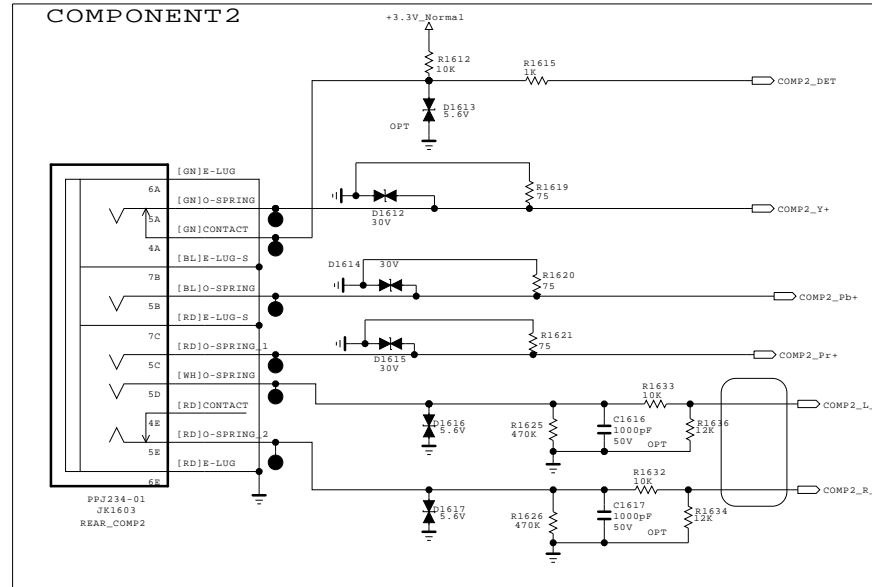

ETHERNET FOR DVB_T2

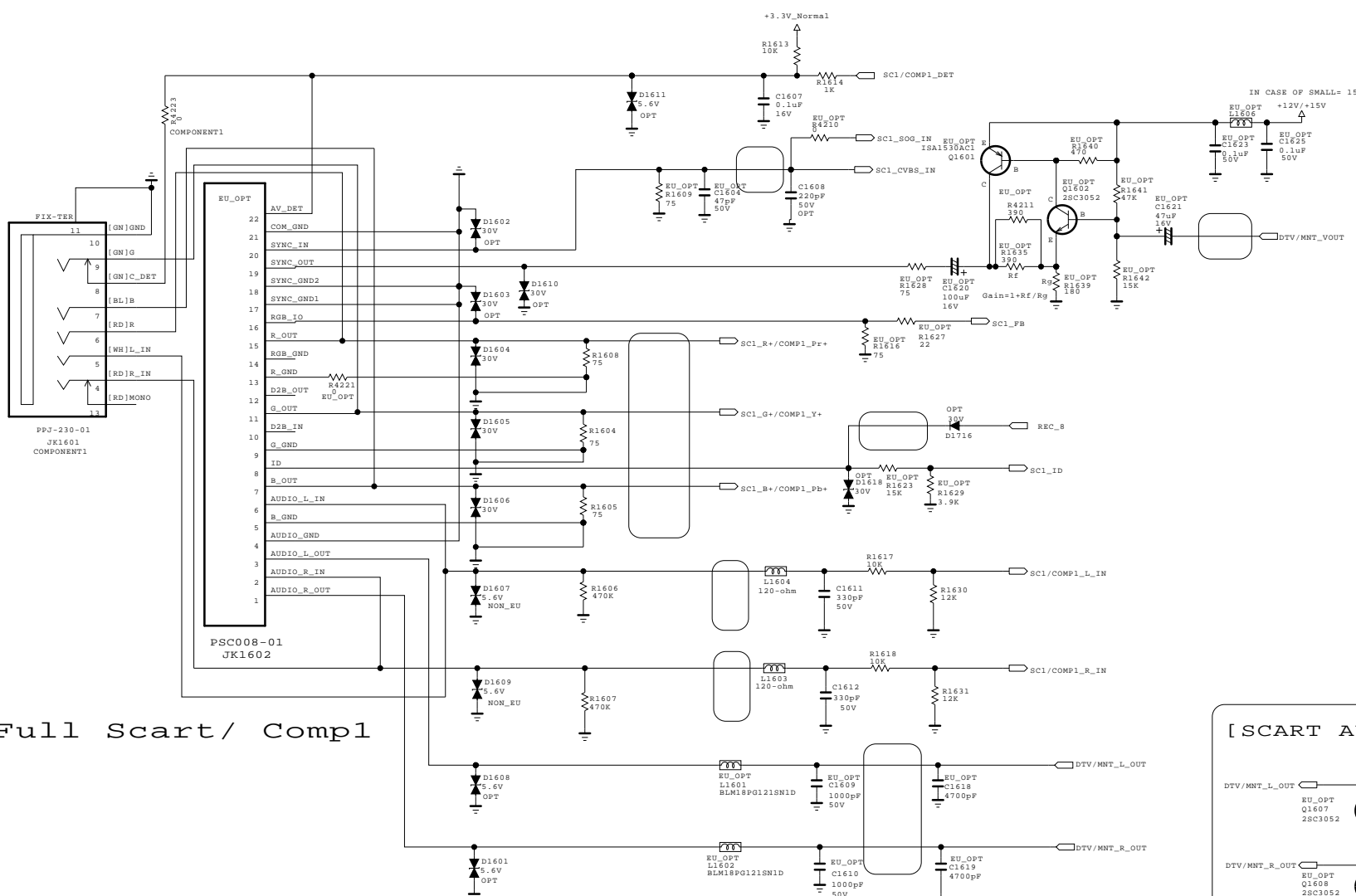
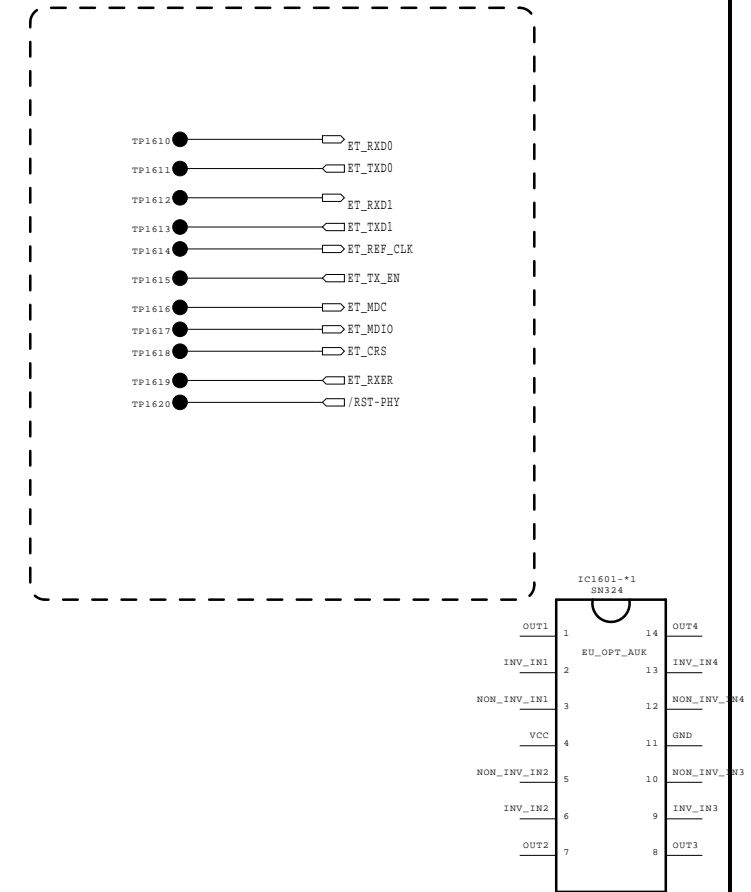

Full Scart/ Comp1

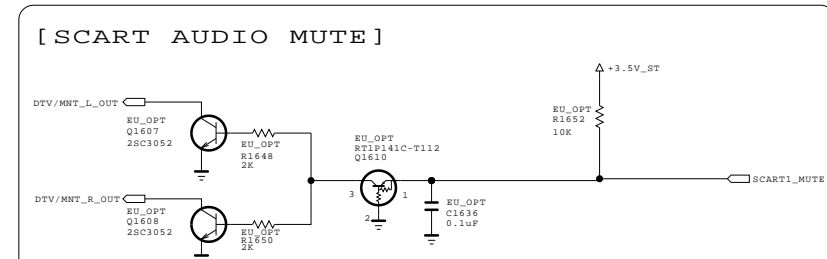
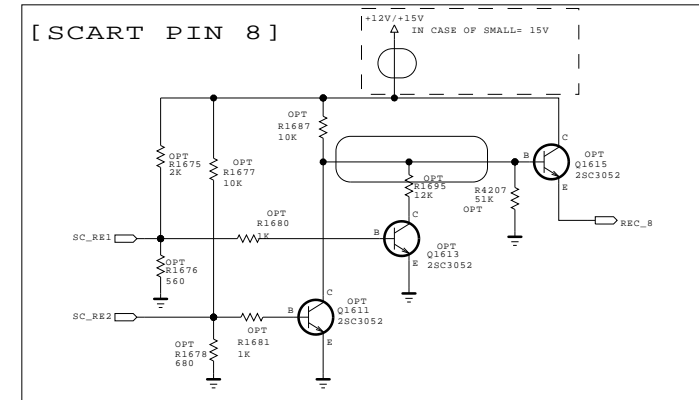
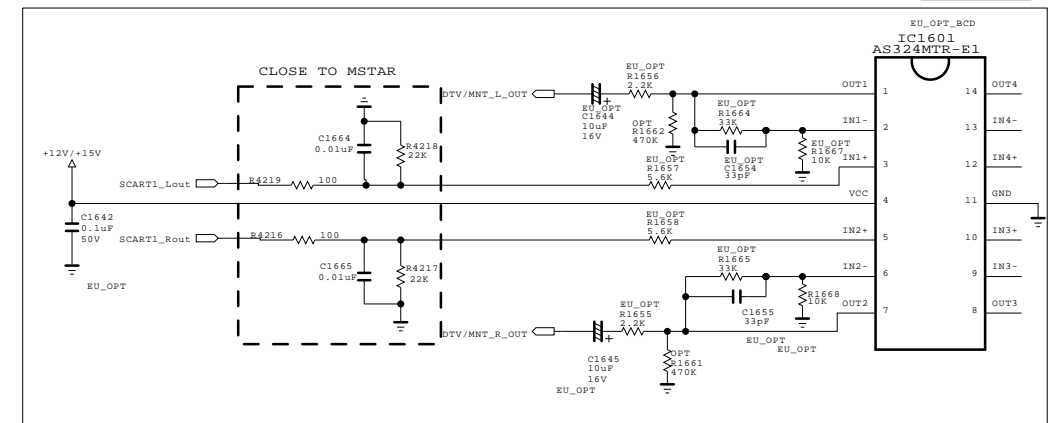

THE Δ SYMBOL MARK OF THIS SCHEMATIC DIAGRAM INCORPORATES SPECIAL FEATURES IMPORTANT FOR PROTECTION FROM X-RADIATION. FILRE AND ELECTRICAL SHOCK HAZARDS, WHEN SERVICING IF IS ESSENTIAL THAT ONLY MANUFACTURES SPECIFIED PARTS BE USED FOR THE CRITICAL COMPONENTS IN THE Δ SYMBOL MARK OF THE SCHEMATIC.

SECRET
LGElectronics



MODEL	GP2R	DATE	20101023
BLOCK	REAR JACK	SHEET	17

* Option name of this page : CI_SLOT
(because of Hong Kong)

CI Region

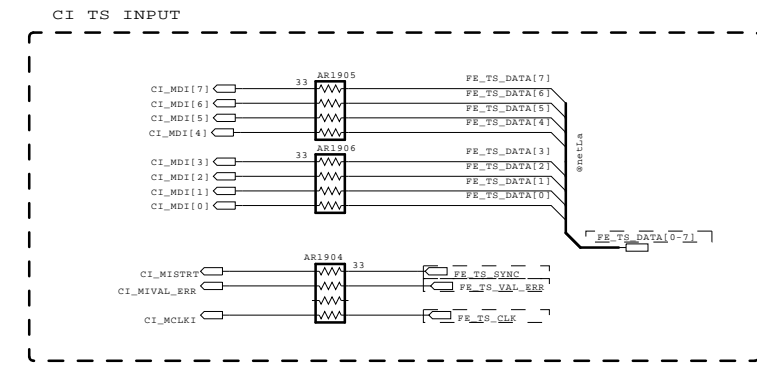
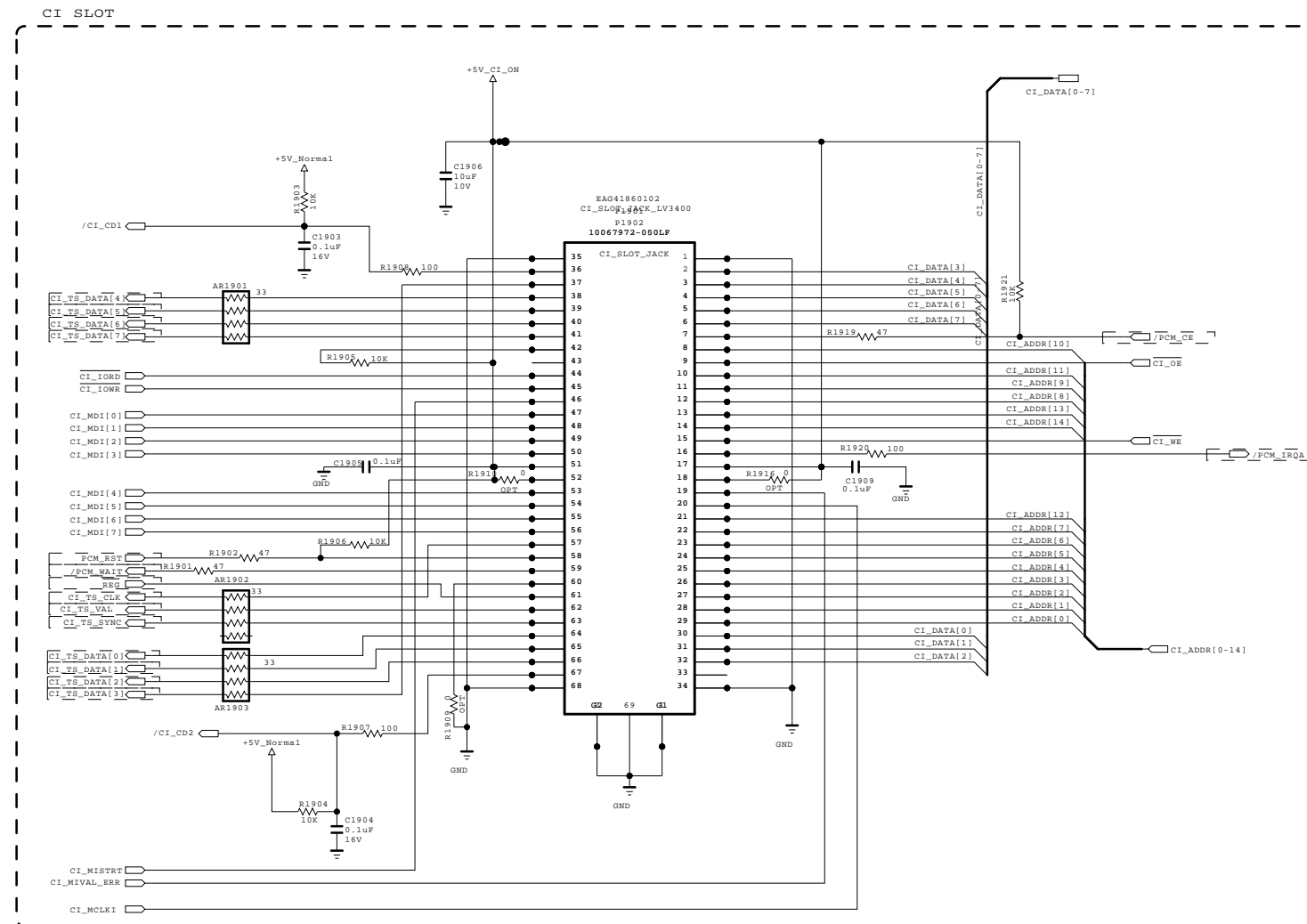

CI HOST I/F

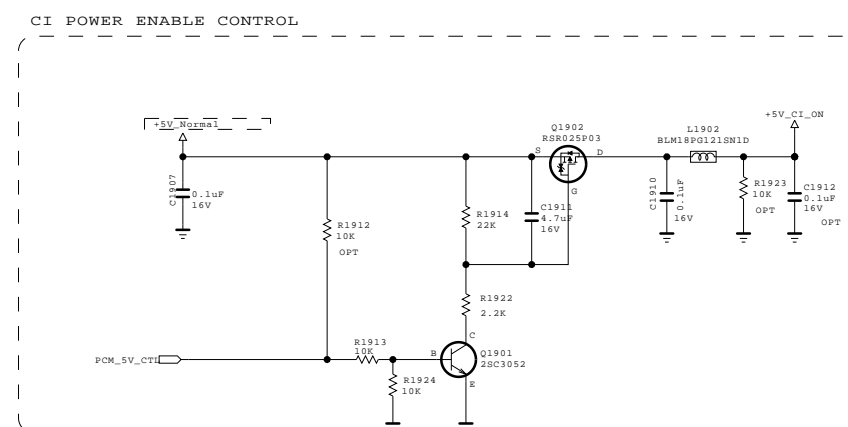
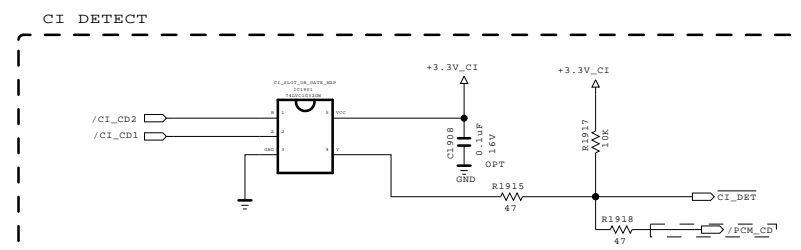
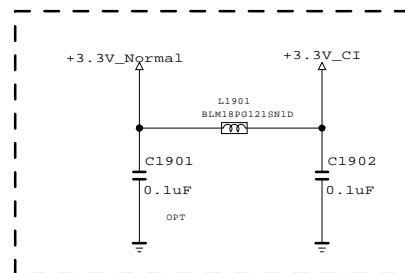
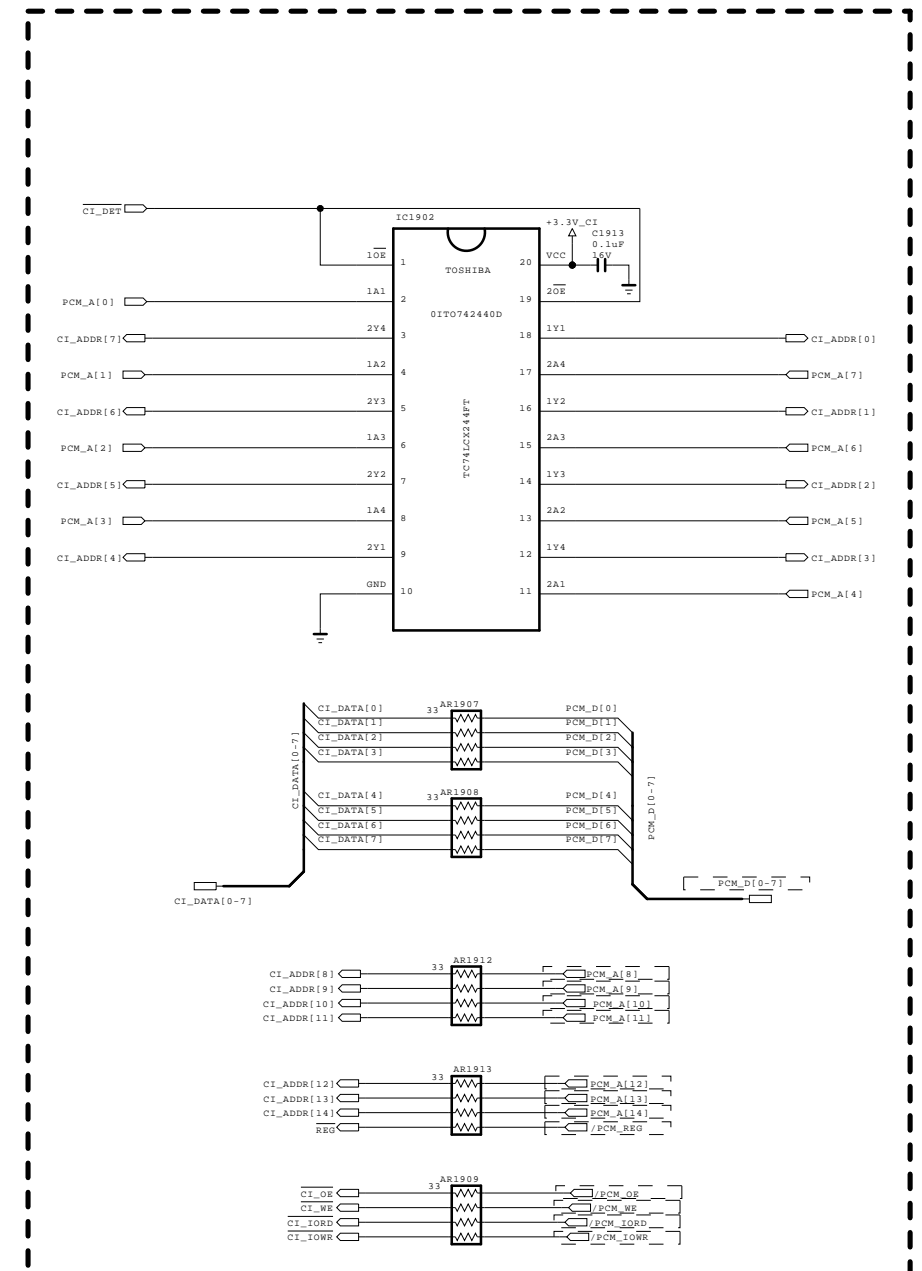

THE Δ SYMBOL MARK OF THIS SCHEMATIC DIAGRAM INCORPORATES SPECIAL FEATURES IMPORTANT FOR PROTECTION FROM X-RADIATION. FILRE AND ELECTRICAL SHOCK HAZARDS, WHEN SERVICING IF IS ESSENTIAL THAT ONLY MANUFACTURES SPECIFIED PARTS BE USED FOR THE CRITICAL COMPONENTS IN THE Δ SYMBOL MARK OF THE SCHEMATIC.



SECRET
LGElectronics

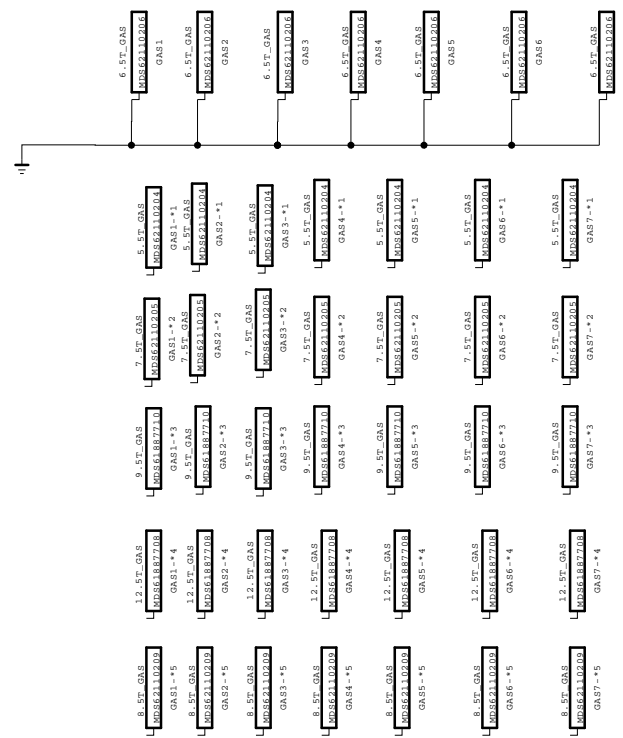

MODEL	GP2R	DATE	20101023
BLOCK	PCMC1	SHEET	20 /

SMD GASKET



THE  SYMBOL MARK OF THIS SCHEMATIC DIAGRAM INCORPORATES SPECIAL FEATURES IMPORTANT FOR PROTECTION FROM X-RADIATION. FILRE AND ELECTRICAL SHOCK HAZARDS, WHEN SERVICING IF IS ESSENTIAL THAT ONLY MANUFACTURES SPECIFIED PARTS BE USED FOR THE CRITICAL COMPONENTS IN THE  SYMBOL MARK OF THE SCHEMATIC.

SECRET
LGElectronics



MODEL	GP2R	DATE	20101023
BLOCK	SMD_GAS	SHEET	20 /

GP2R_GLOBAL_TUNER_BLOCK for Small Model

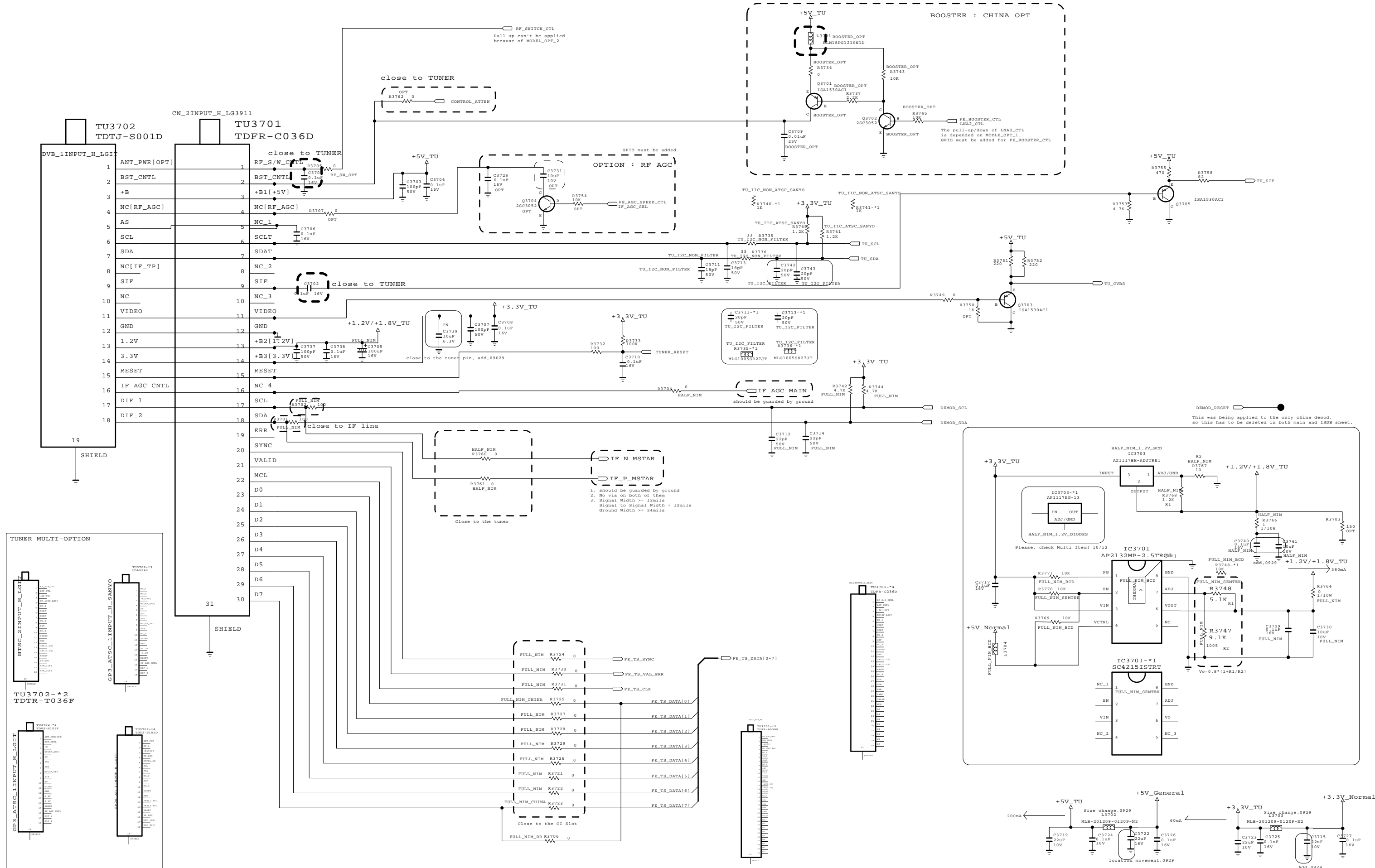

THE SYMBOL MARK OF THIS SCHEMATIC DIAGRAM INCORPORATES SPECIAL FEATURES IMPORTANT FOR PROTECTION FROM X-RADIATION. FILRE AND ELECTRICAL SHOCK HAZARDS, WHEN SERVICING IF IS ESSENTIAL THAT ONLY MANUFACTURERS SPECIFIED PARTS BE USED FOR THE CRITICAL COMPONENTS IN THE SYMBOL MARK OF THE SCHEMATIC.

SECRET
LGElectronics



MODEL	GP2R	DATE	20101023
BLOCK	TUNER_SMALL	SHEET	25

NON_L/DIM_LED/DRIVER

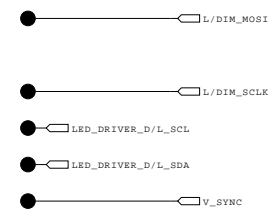

NON_3D_SG

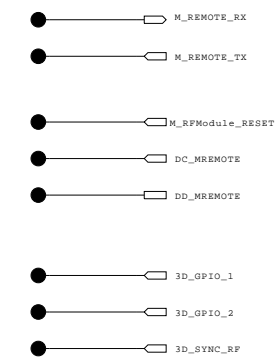

THE SYMBOL MARK OF THIS SCHEMATIC DIAGRAM INCORPORATES SPECIAL FEATURES IMPORTANT FOR PROTECTION FROM X-RADIATION. FILRE AND ELECTRICAL SHOCK HAZARDS, WHEN SERVICING IF IS ESSENTIAL THAT ONLY MANUFACTURES SPECIFIED PARTS BE USED FOR THE CRITICAL COMPONENTS IN THE SYMBOL MARK OF THE SCHEMATIC.

SECRET
 LGElectronics



MODEL	GP2R	DATE	20101023
BLOCK	NON_L/DIM	SHEET	26 /

TN_module_LED_DRIVER_CIRCUIT

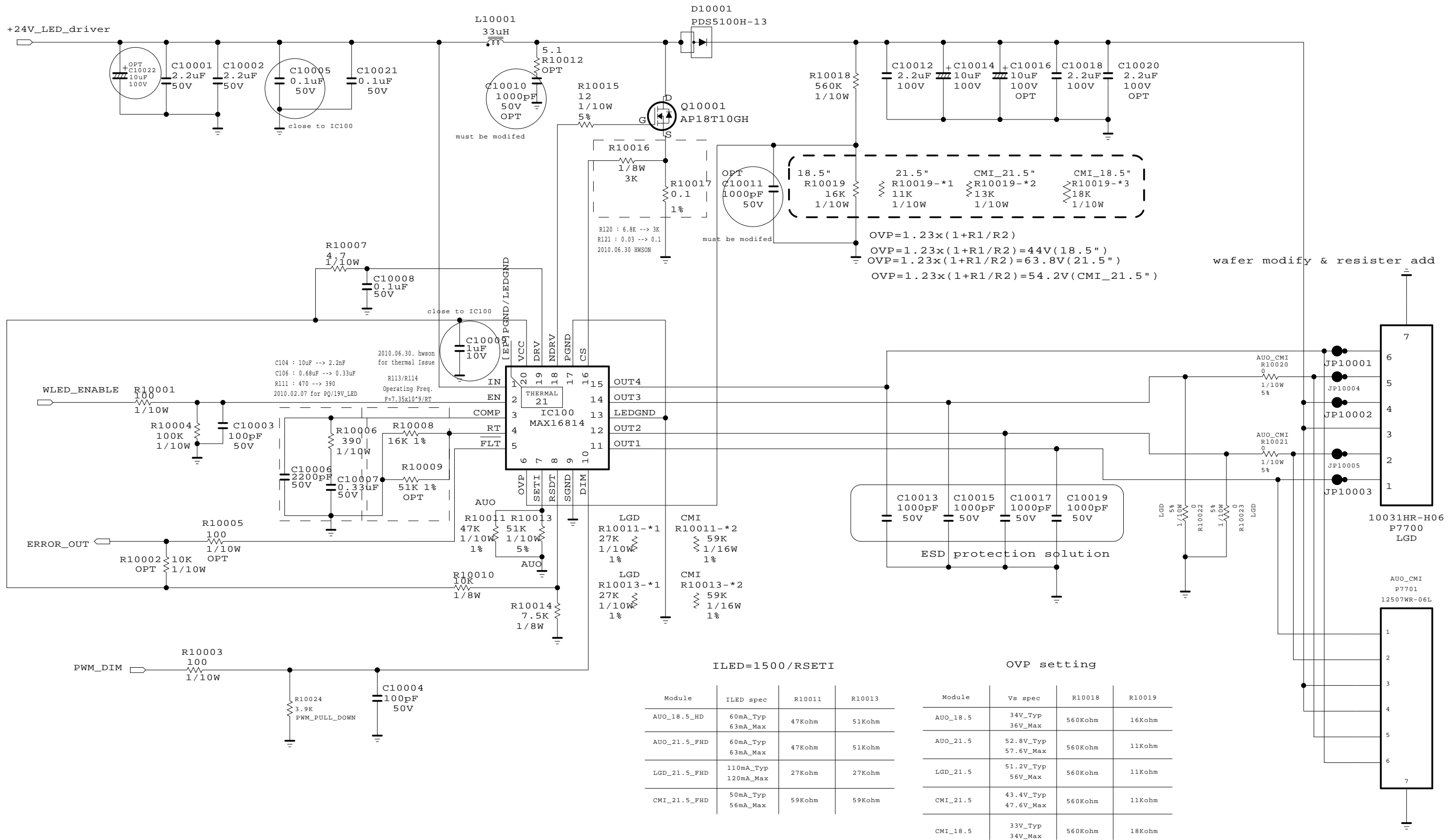

THE ⚠ SYMBOL MARK OF THIS SCHEMATIC DIAGRAM INCORPORATES SPECIAL FEATURES IMPORTANT FOR PROTECTION FROM X-RADIATION. FILRE AND ELECTRICAL SHOCK HAZARDS, WHEN SERVICING IF IS ESSENTIAL THAT ONLY MANUFACTURES SPECIFIED PARTS BE USED FOR THE CRITICAL COMPONENTS IN THE ⚠ SYMBOL MARK OF THE SCHEMATIC.



MODEL	GP2R	DATE	20101023
BLOCK	TN_DRIVER	SHEET	29 /

LVDS_TN

[30Pin FHD LVDS Connector]
(For FHD 60Hz_Small)

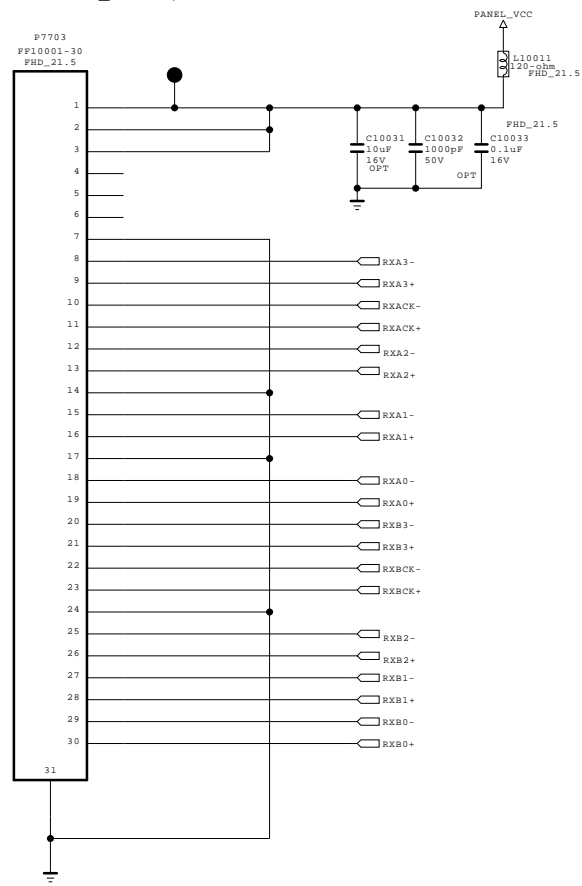

[30Pin HD LVDS Connector]
(For HD 60Hz_Small)

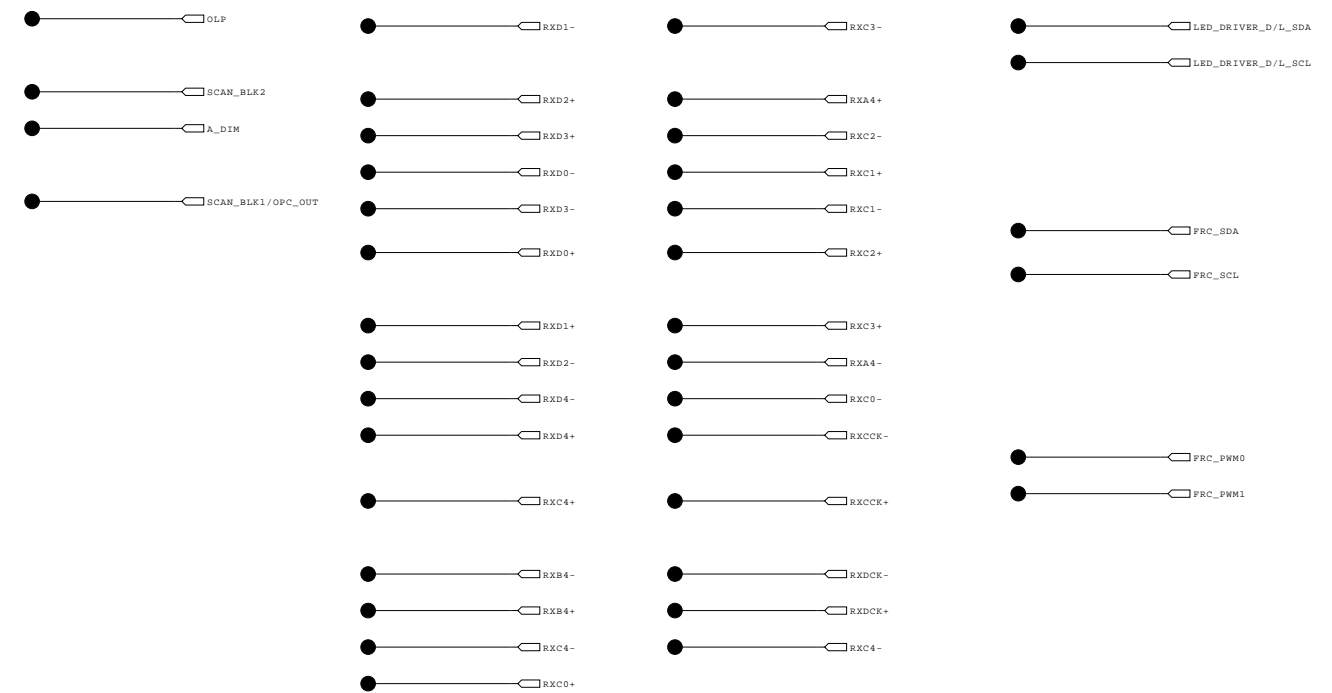
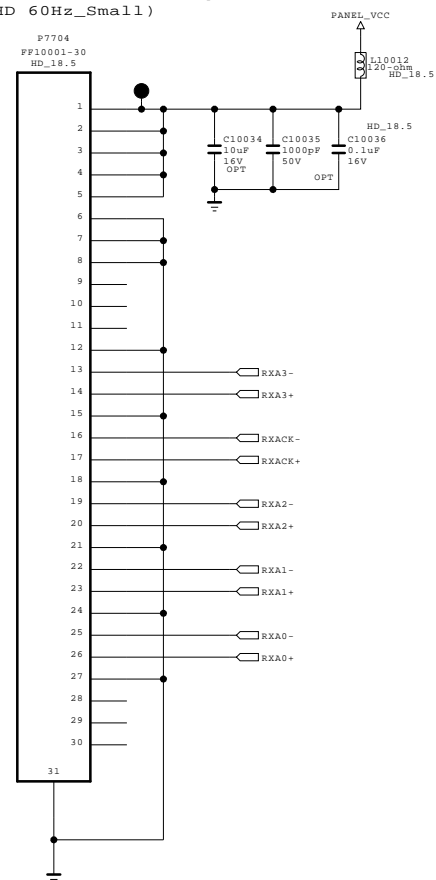

SIDE CVBS PHONE JACK
(New Item Development)

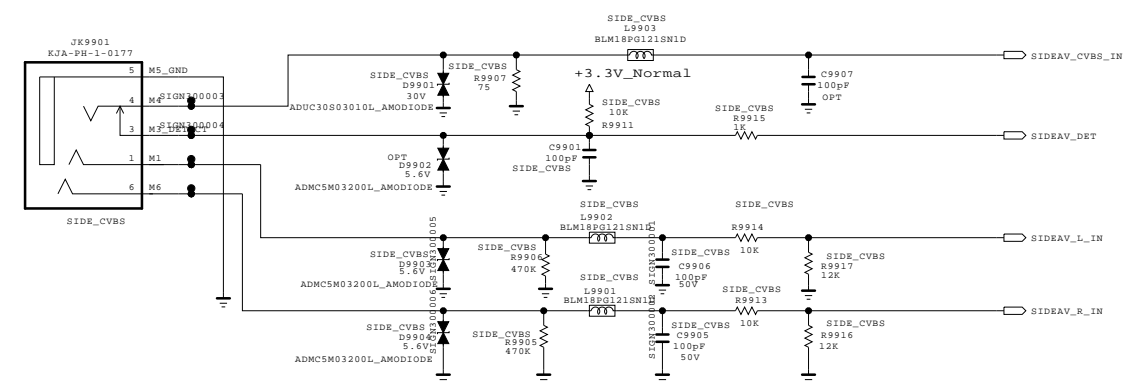

THE SYMBOL MARK OF THIS SCHEMATIC DIAGRAM INCORPORATES SPECIAL FEATURES IMPORTANT FOR PROTECTION FROM X-RADIATION. FILRE AND ELECTRICAL SHOCK HAZARDS, WHEN SERVICING IF IS ESSENTIAL THAT ONLY MANUFACTURES SPECIFIED PARTS BE USED FOR THE CRITICAL COMPONENTS IN THE SYMBOL MARK OF THE SCHEMATIC.



SECRET
LGElectronics

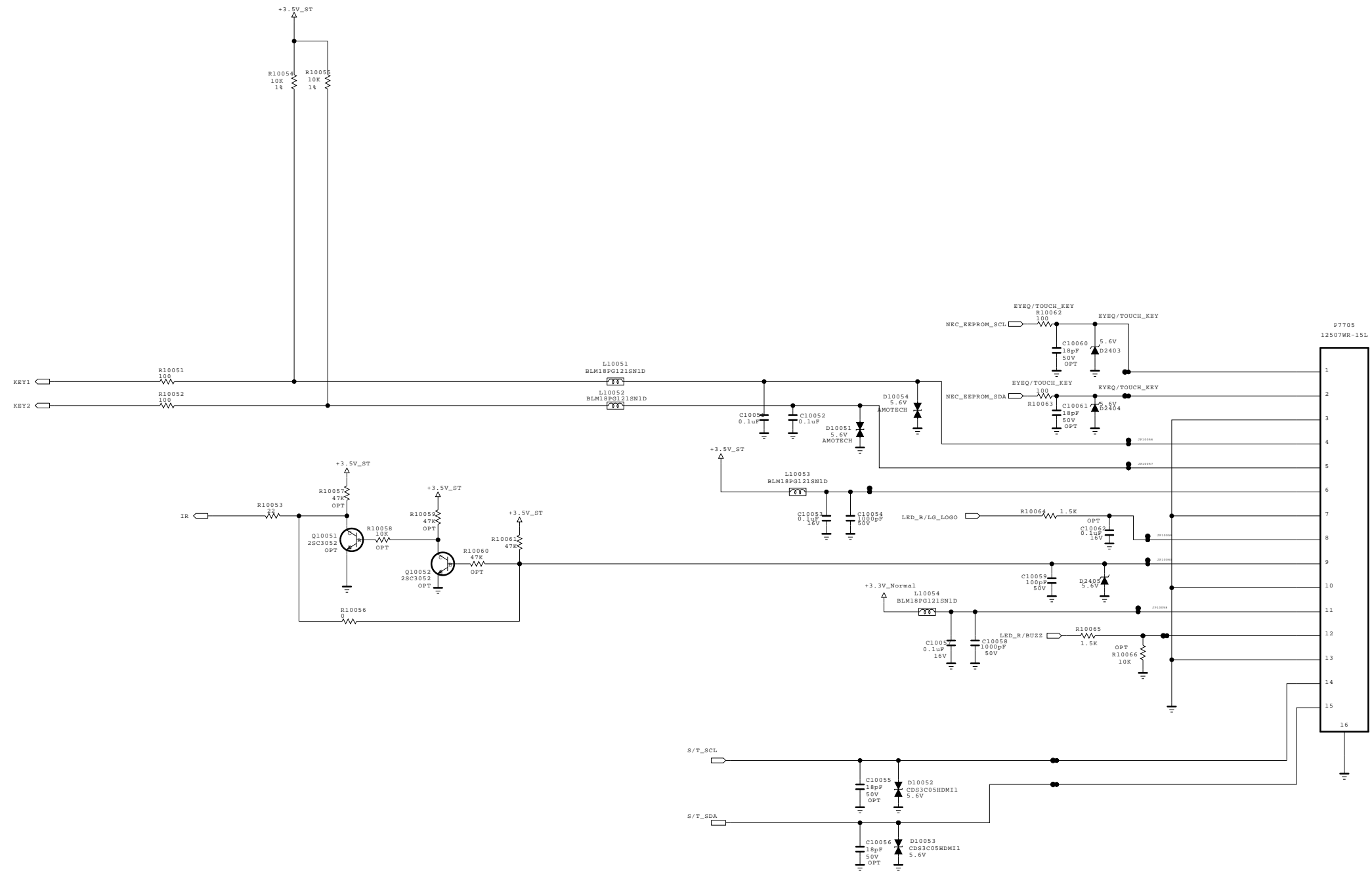

MODEL	GP2R	DATE	20101220
BLOCK	LVDS_SIDE	SHEET	30 /

TN CONTROL IR & LED



THE  SYMBOL MARK OF THIS SCHEMATIC DIAGRAM INCORPORATES SPECIAL FEATURES IMPORTANT FOR PROTECTION FROM X-RADIATION. FILRE AND ELECTRICAL SHOCK HAZARDS, WHEN SERVICING IF IS ESSENTIAL THAT ONLY MANUFACTURES SPECIFIED PARTS BE USED FOR THE CRITICAL COMPONENTS IN THE  SYMBOL MARK OF THE SCHEMATIC.

SECRET
LGElectronics



MODEL	GP2R	DATE	20101023
BLOCK	TN_IR/CONT	SHEET	31 /

S7M-PLUS
IC101
LGE107DC-RP [S7M+ DIVX/MS10]

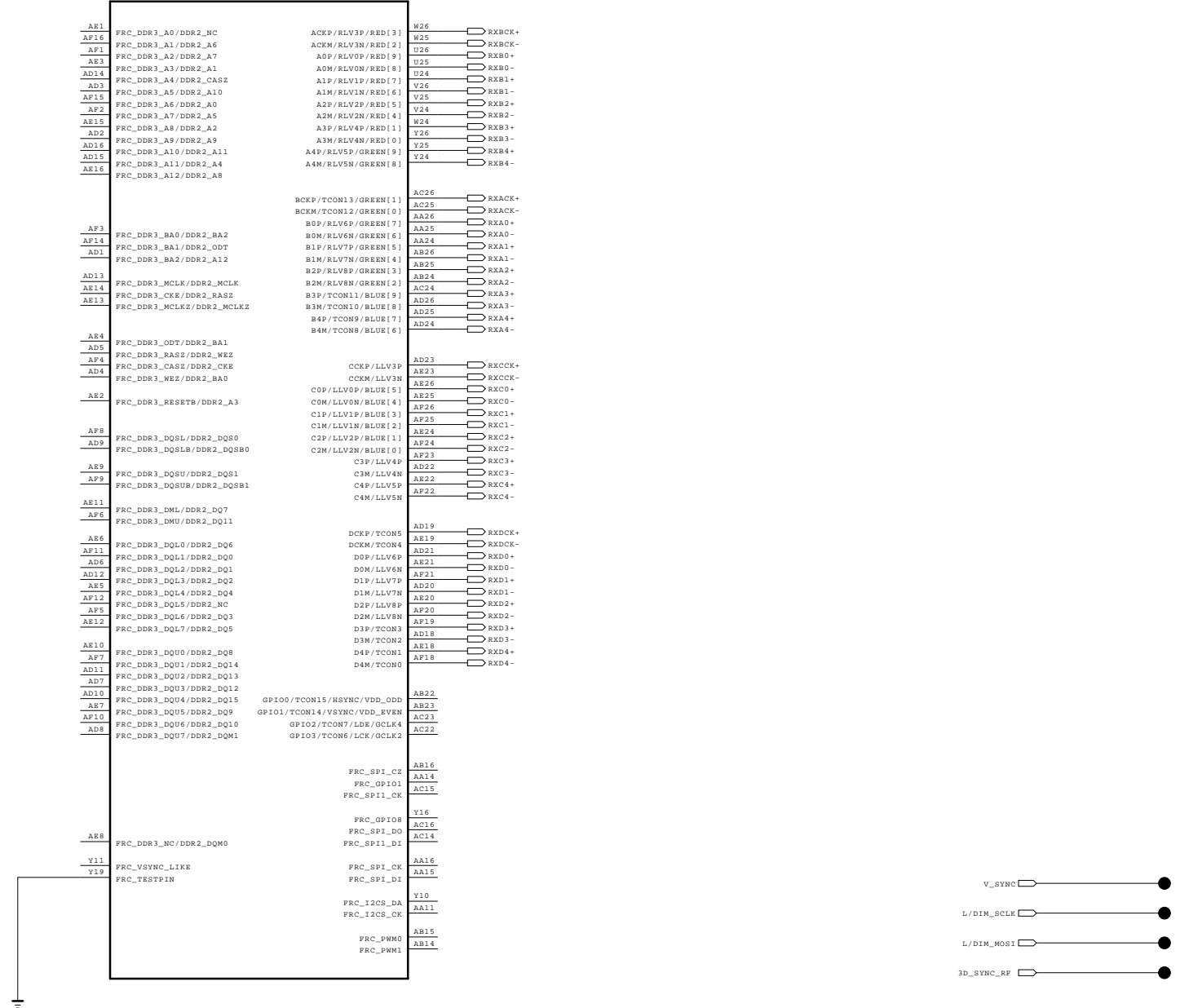

THE SYMBOL MARK OF THIS SCHEMATIC DIAGRAM INCORPORATES SPECIAL FEATURES IMPORTANT FOR PROTECTION FROM X-RADIATION. FILRE AND ELECTRICAL SHOCK HAZARDS, WHEN SERVICING IF IS ESSENTIAL THAT ONLY MANUFACTURES SPECIFIED PARTS BE USED FOR THE CRITICAL COMPONENTS IN THE SYMBOL MARK OF THE SCHEMATIC.

SECRET
LGElectronics



MODEL		DATE	
BLOCK		SHEET	/



LCD TV Repair Guide

11 years New Basic Models

Contents

- 1. Product Roadmap**
- 2. Main PCB layout**
- 3. Block Diagram**
- 4. Interconnection**
- 5. Standard Repair Process**

LCD TV EU Group
LCD TV Research Department

JAN. 28th, 2011



LCD TV Repair Guide

'11 years New Models

< Applicable Basic Model >

xxLK330, xxLK430, xxLK450, xxLK530, xxLK550

xxLV2300, xxLV2500, xxLV2540, xxLV3400

xxLV3500, xxLV3550, xxLV5500, xxLV4500

xxLW4500 (3D)



2011

Lamp

Tool	Pan EU	UK(U)	Nordic(N)	Italy(A)
LK33	22LK330-ZB	22LK330U-ZB	22LK330N-ZB	22LK330A-ZB
	26LK330-ZB	26LK330U-ZB	26LK330N-ZB	26LK330A-ZB
	32LK330-ZB	32LK330U-ZB	32LK330N-ZB	32LK330A-ZB
	22LK331-ZA			
	26LK331-ZA			
	32LK331-ZA			
LK43	32LK430-ZA	32LK430U-ZA	32LK430N-ZA	32LK430A-ZA
	37LK430-ZA	37LK430U-ZA	37LK430N-ZA	37LK430A-ZA
	42LK430-ZA	42LK430U-ZA	42LK430N-ZA	42LK430A-ZA
LK45	32LK450-ZB	32LK450U-ZB	32LK450N-ZB	32LK450A-ZB
	37LK450-ZB	37LK450U-ZB	37LK450N-ZB	37LK450A-ZB
	42LK450-ZB	42LK450U-ZB	42LK450N-ZB	42LK450A-ZB
	32LK451-ZA			
	37LK451-ZA			
	42LK451-ZA			
LK53	32LK530-ZC	32LK530U-ZC	32LK530N-ZC	32LK530A-ZC
	42LK530-ZC	42LK530U-ZC	42LK530N-ZC	42LK530A-ZC
	47LK530-ZC	47LK530U-ZC	47LK530N-ZC	47LK530A-ZC
LK55	32LK550-ZA	32LK550U-ZA	32LK550N-ZA	32LK550A-ZA
	42LK550-ZA	42LK550U-ZA	42LK550N-ZA	42LK550A-ZA
	32LK551-ZB			
	42LK551-ZB			

Edge
LED

Tool	Pan EU	UK(U)	Nordic(N)	Italy(A)
LV23	19LV2300-ZA			
	22LV2300-ZA			
LV25	19LV2500-ZA	19LV250U-ZA	19LV250N-ZA	19LV250A-ZA
	22LV2500-ZA	22LV250U-ZA	22LV250N-ZA	22LV250A-ZA
	26LV2500-ZA	26LV250U-ZA	26LV250N-ZA	26LV250A-ZA
	32LV2500-ZA	32LV250U-ZA	32LV250N-ZA	32LV250A-ZA
	26LV2540-ZE	26LV254U-ZE	26LV254N-ZE	26LV254A-ZE
	32LV2540-ZE	32LV254U-ZE	32LV254N-ZE	32LV254A-ZE
	32LV3400-ZA	32LV340U-ZA	32LV340N-ZA	32LV340A-ZA
LV34	42LV3400-ZA	42LV340U-ZA	42LV340N-ZA	42LV340A-ZA
	32LW3450-ZB	32LW345U-ZB	32LW345N-ZB	32LW345A-ZB
	42LW3450-ZB	42LW345U-ZB	42LW345N-ZB	42LW345A-ZB
LV35	32LV3500-ZA	32LV350U-ZA	32LV350N-ZA	32LV350A-ZA
	37LV3500-ZA	37LV350U-ZA	37LV350N-ZA	37LV350A-ZA
	42LV3500-ZA	42LV350U-ZA	42LV350N-ZA	42LV350A-ZA
	47LV3500-ZA	47LV350U-ZA	47LV350N-ZA	47LV350A-ZA
	32LV3550-ZB	32LV355U-ZB	32LV355N-ZB	32LV355A-ZB
	37LV3550-ZB	37LV355U-ZB	37LV355N-ZB	37LV355A-ZB
	42LV3550-ZB	42LV355U-ZB	42LV355N-ZB	42LV355A-ZB
	47LV3550-ZB	47LV355U-ZB	47LV355N-ZB	47LV355A-ZB
	32LV3551-ZD			
	37LV3551-ZD			
	42LV3551-ZD			
LV45	32LV4500-ZC	32LV450U-ZC	32LV450N-ZC	32LV450A-ZC
	37LV4500-ZC	37LV450U-ZC	37LV450N-ZC	37LV450A-ZC
	42LV4500-ZC	42LV450U-ZC	42LV450N-ZC	42LV450A-ZC
	47LV4500-ZC	47LV450U-ZC	47LV450N-ZC	47LV450A-ZC
LW45	32LW4500-ZB	32LW450U-ZB	32LW450N-ZB	32LW450A-ZB
	37LW4500-ZB	37LW450U-ZB	37LW450N-ZB	37LW450A-ZB
	42LW4500-ZB	42LW450U-ZB	42LW450N-ZB	42LW450A-ZB
	47LW4500-ZB	47LW450U-ZB	47LW450N-ZB	47LW450A-ZB
LV55	22LV5500-ZC	22LV550U-ZC	22LV550N-ZC	22LV550A-ZC
	26LV5500-ZC	26LV550U-ZC	26LV550N-ZC	26LV550A-ZC

3D

19/22/26LV2500 (50HZ)

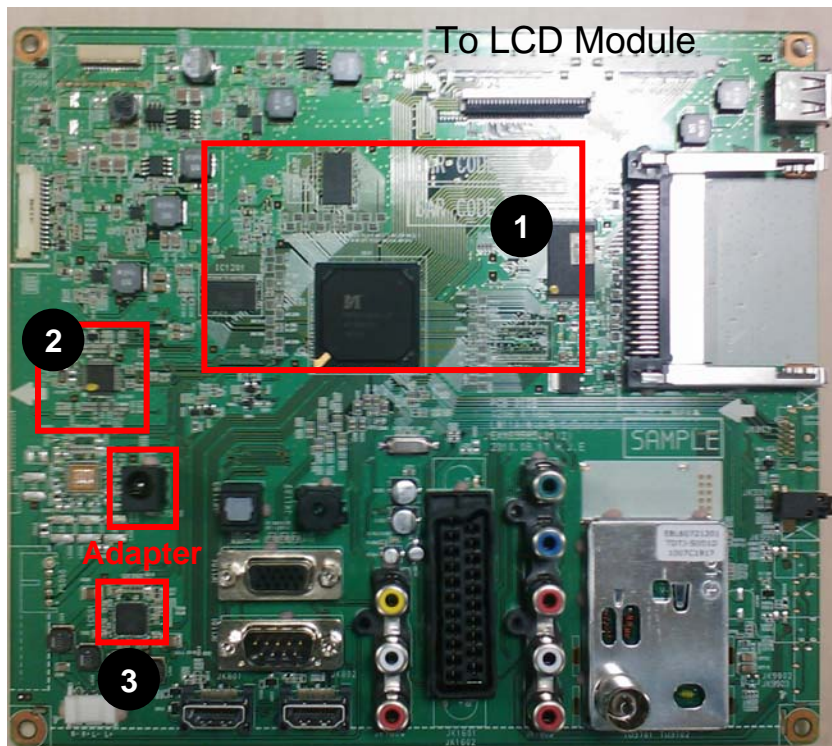

- 1 Main processor, DDR Memory
Flash Memory
- 2 Micom for Key/IR sensing
- 3 Audio AMP (5W+5W)

* 19/22/26LV2500_S7 Reused ('11)

Main IC : LGE101_Mstar

Tuner Type : TDTJ-S001D (DVB-T/C)

Display Type (Resolution) : LED TV (1366 x 768)

Interface : HDMI 2EA , Component 1EA, AV 1EA, USB 1EA

**Difference : Without FRC, HDMI Position , Resolution , Interface, Wafer
Position (Sub)**

22/26LK330 (50HZ)

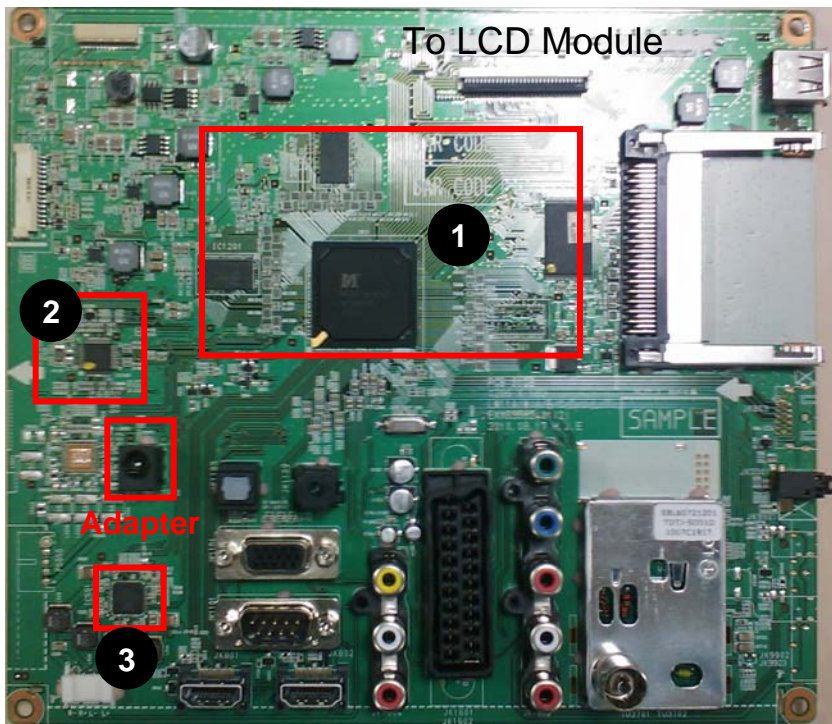

- 1 Main processor, DDR Memory
Flash Memory
- 2 Micom for Key/IR sensing
- 3 Audio AMP (5W+5W)

* 22/26LK330_S7 Reused ('11)

Main IC : LGE101_Mstar

Tuner Type : TDTJ-S001D (DVB-T/C)

Display Type (Resolution) : LCD TV (1366 x 768)

Interface : HDMI 2EA , Component 1EA, AV 1EA, USB 1EA

Difference : Without FRC, HDMI Position , Resolution , Interface, Wafer
Position (Sub)

32/37/42/47LK450 (50HZ)

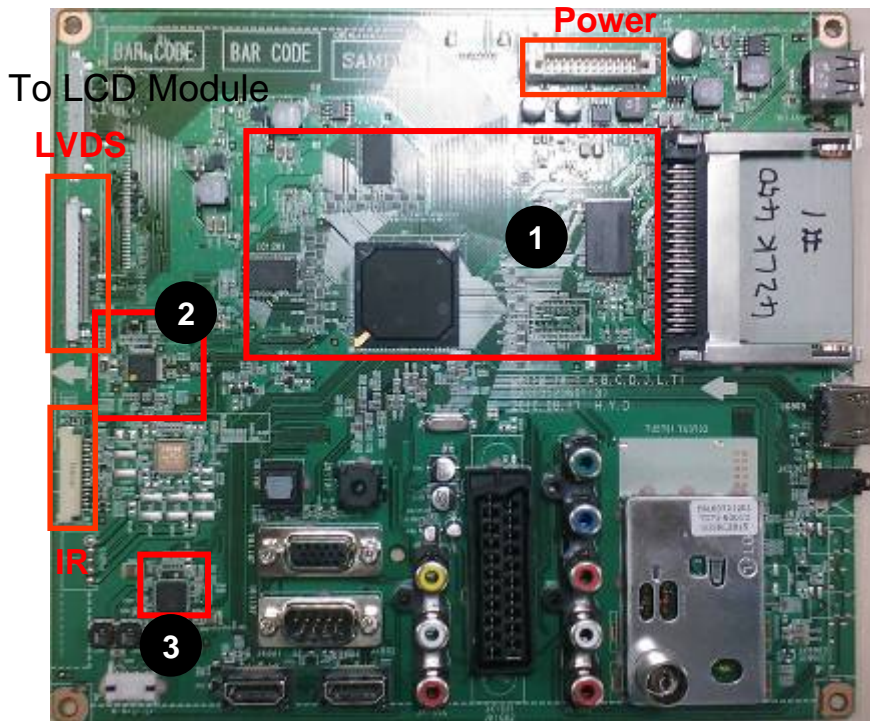

- 1 Main processor, DDR Memory
Flash Memory
- 2 Micom for Key/IR sensing
- 3 Audio AMP (10W+10W)

* 32/37/42/47LK450_S7 Reused ('11)

Main IC : LGE101_Mstar

Tuner Type : TDTJ-S001D (DVB-T/C)

Display Type (Resolution) : LCD TV (1920 x 1080)

Interface : HDMI 3EA , Component 1EA, AV 1EA, USB 1EA

Difference : Without FRC, HDMI Position , Resolution , Interface, Wafer Position (Sub)

32/37/42/47/55LW4500 (100HZ)

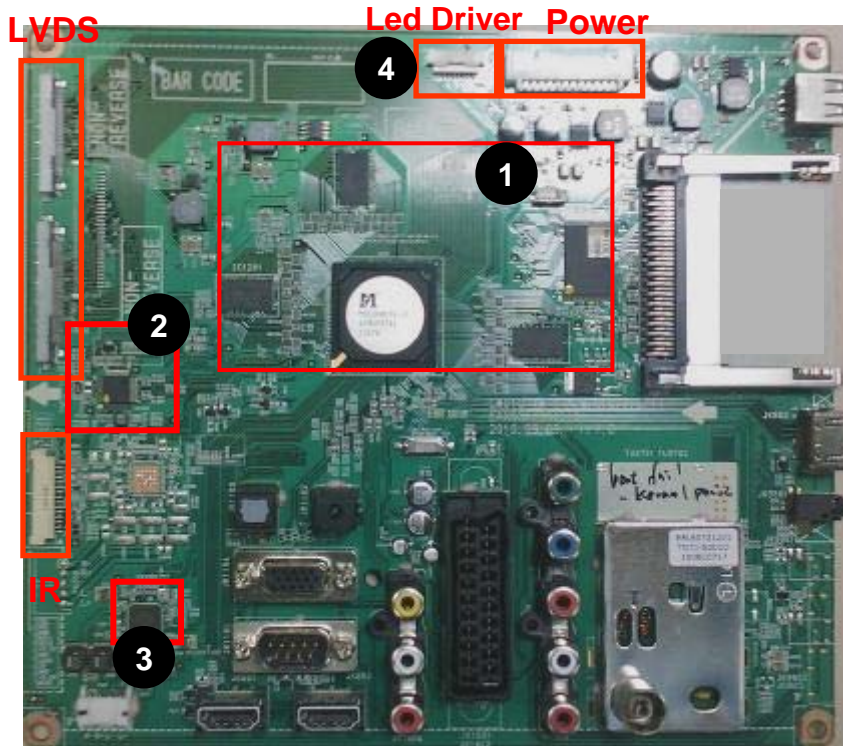

- 1 Main processor, DDR Memory
Flash Memory
- 2 Micom for Key/IR sensing
- 3 Audio AMP (10W+10W)
- 4 LED Driver connection (with local dimming)

* 37LW4500_S7 Reused ('11)
Main IC : LGE107_Mstar
Tuner Type : TDTJ-S001D (DVB-T/C)
Display Type (Resolution) : 3D, LED TV (1920 x 1080)
Interface : HDMI 3EA , Component 1EA, AV 1EA, USB 1EA
Difference : HDMI Position , Interface, Wafer Position (LVDS, Power, Sub)

Block diagram

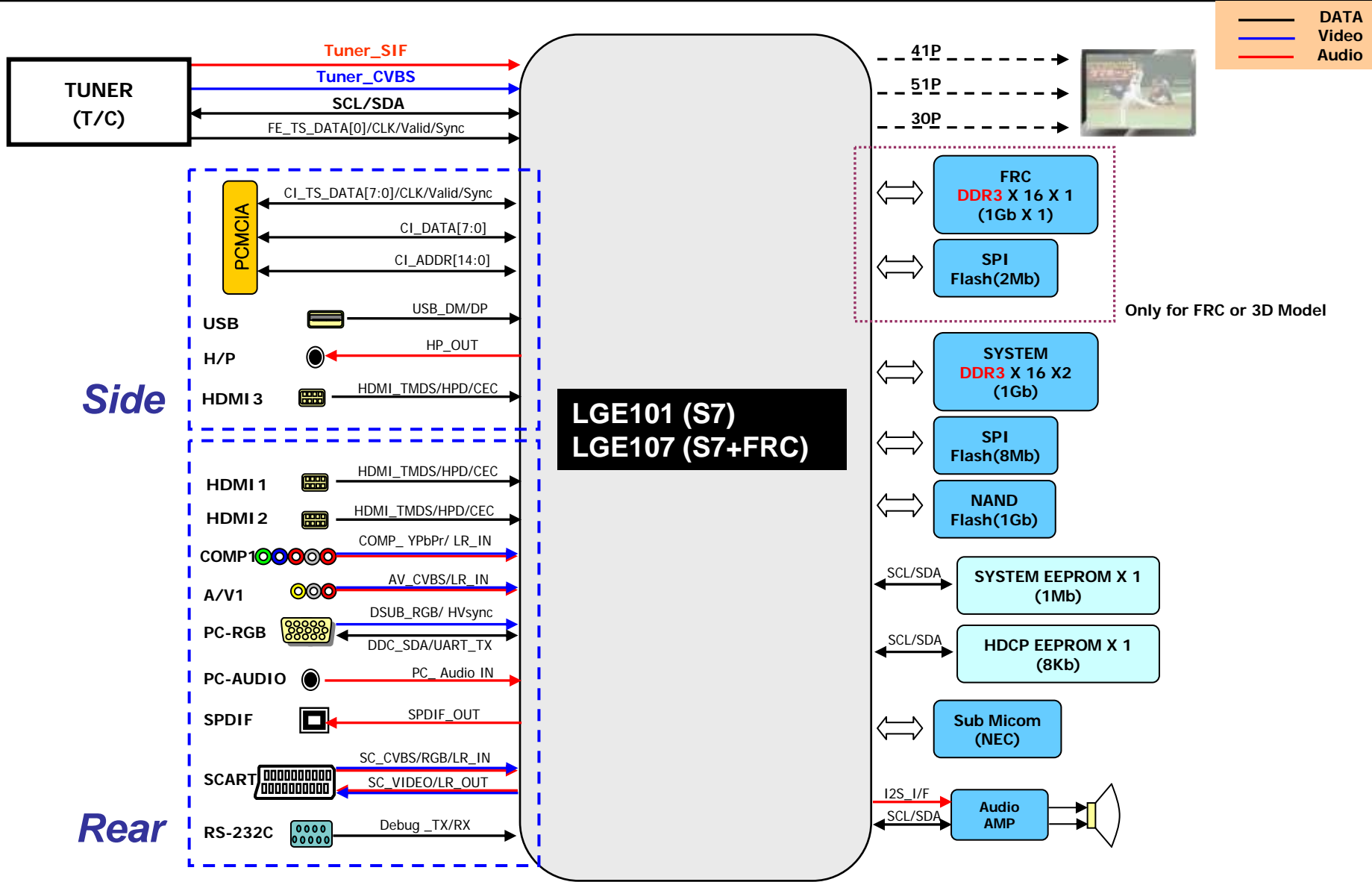

Side

Rear

Only for FRC or 3D Model

19/22LV2500

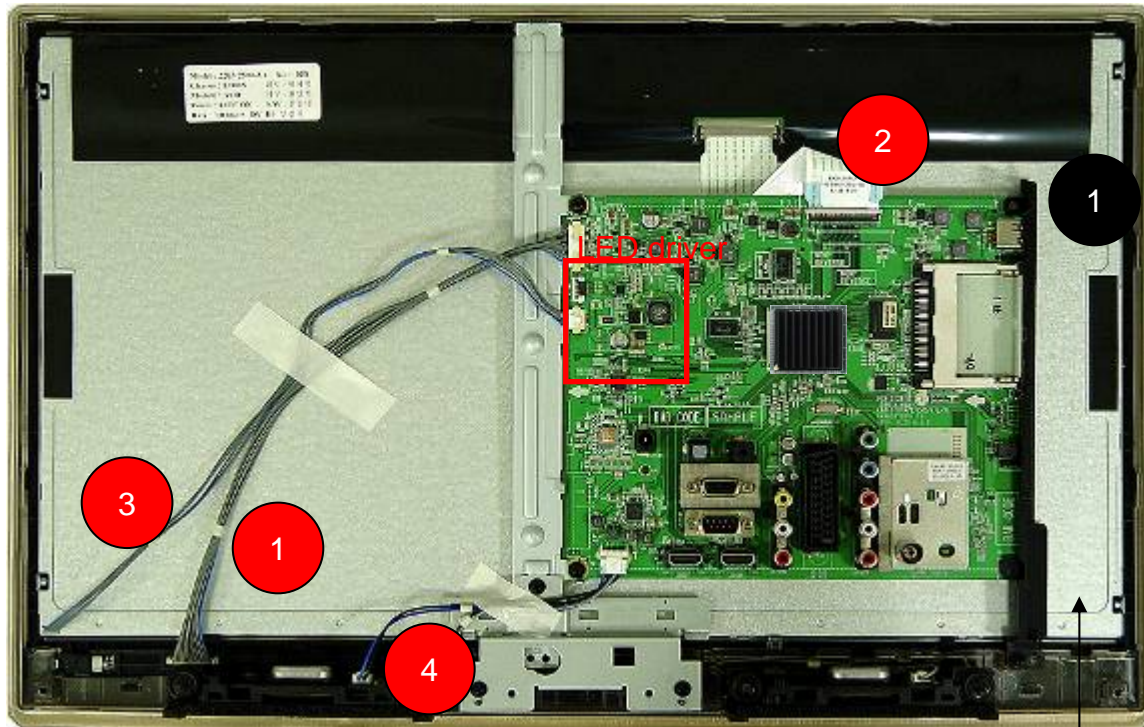

[PCBs]

- 1 Main PCB
- 2 Soft Touch Key/IR PCB

[Cables]

- 1 Soft Touch key/IR cable
- 2 Main / Module LVDS cable
- 3 LED driver / Module cable
- 4 SPK cable

LCD Module



19/22LV5500

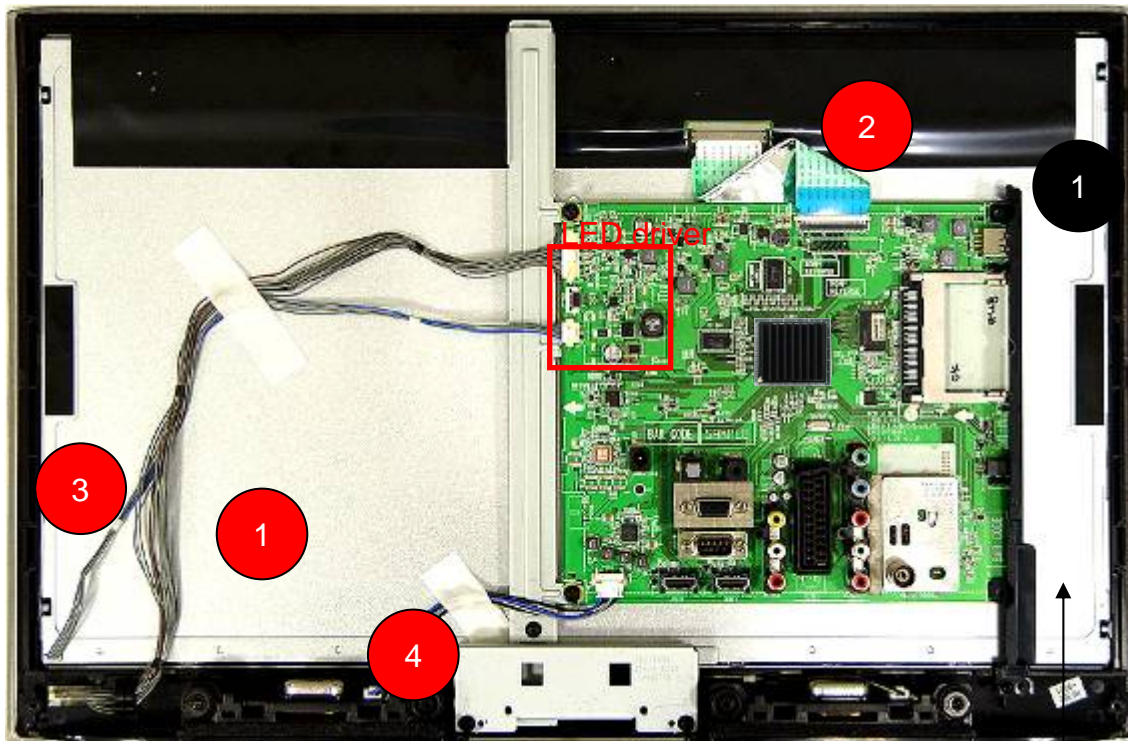

[PCBs]

- 1 Main PCB
- 2 Soft Touch Key/IR PCB

[Cables]

- 1 Soft Touch key/IR cable
- 2 Main / Module LVDS cable
- 3 LED driver / Module cable
- 4 SPK cable

LCD Module



26LV2500

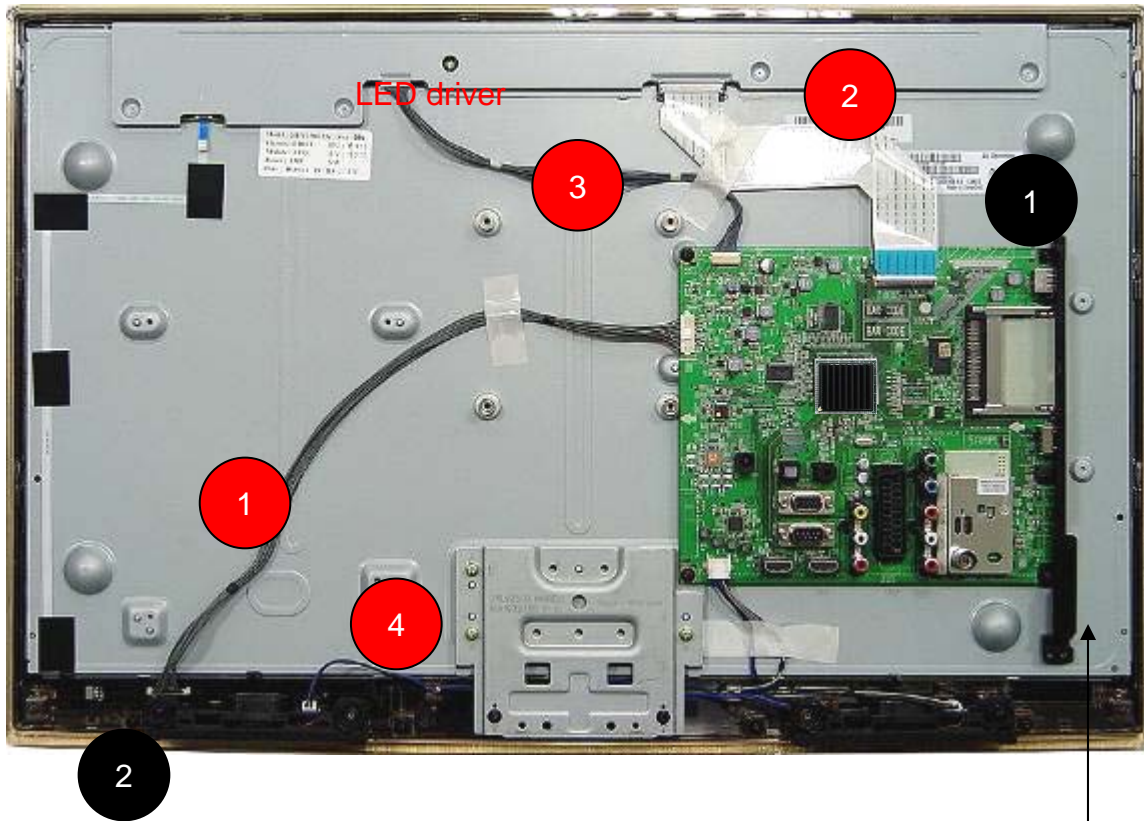

[PCBs]

- 1 Main PCB
- 2 Soft Touch Key/IR PCB

[Cables]

- 1 Soft Touch key/IR cable
- 2 Main / Module LVDS cable
- 3 LED driver / Module cable
- 4 SPK cable

LCD Module

26LV5500

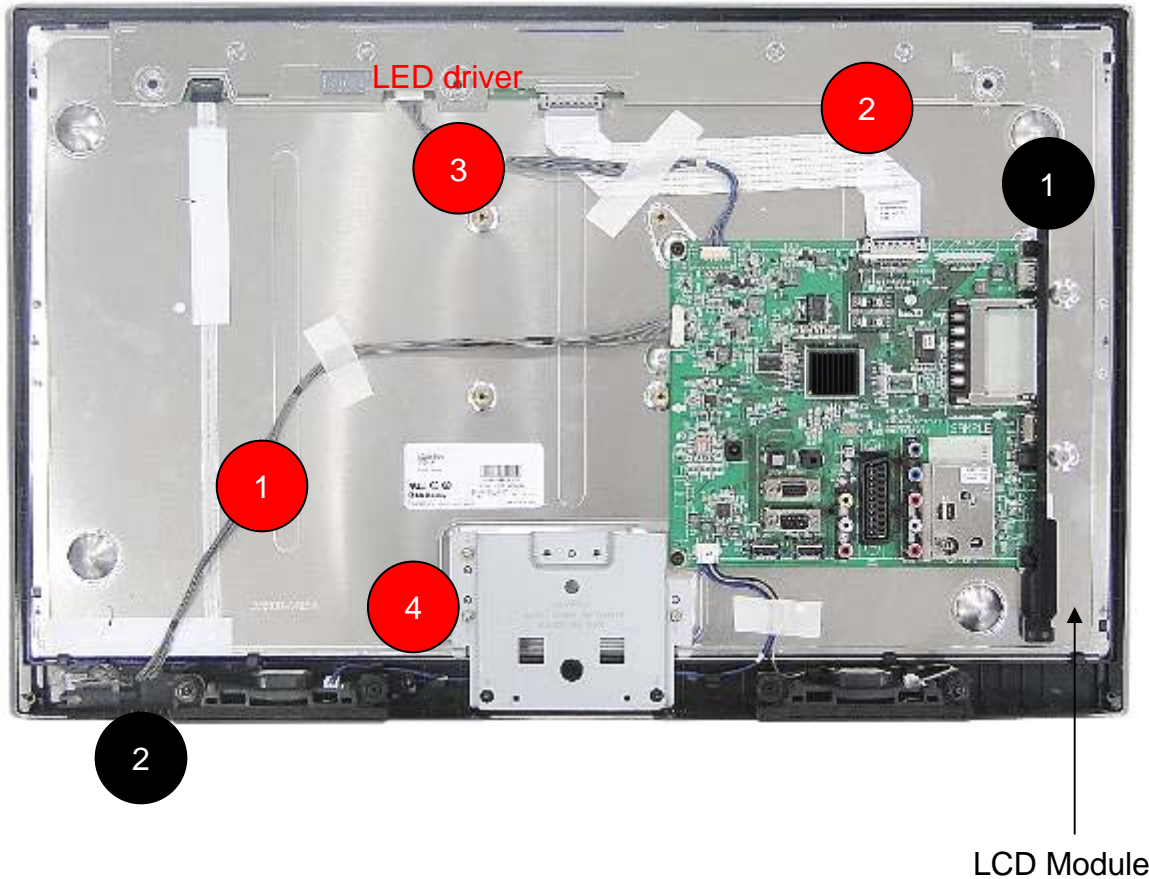

[PCBs]

- 1 Main PCB
- 2 Soft Touch Key/IR PCB

[Cables]

- 1 Soft Touch key/IR cable
- 2 Main / Module LVDS cable
- 3 LED driver / Module cable
- 4 SPK cable

LCD Module

32LV2500

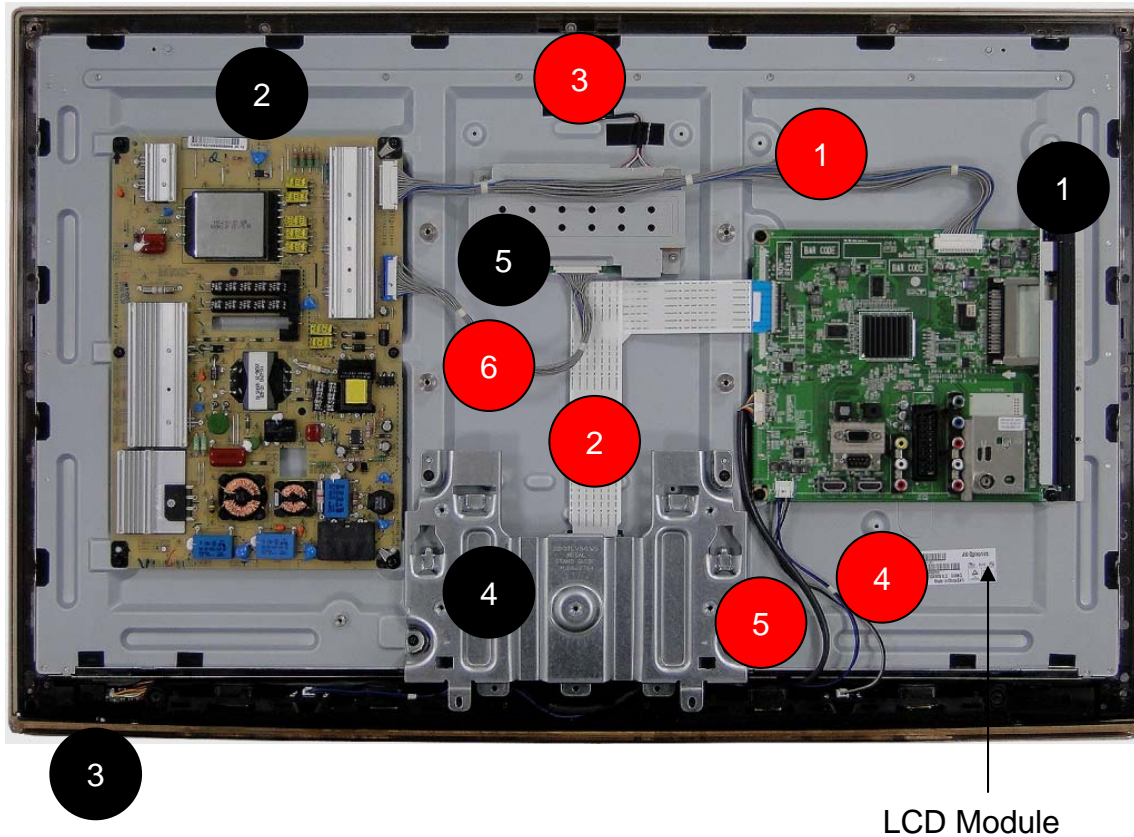

[PCBs]

- 1 Main PCB
- 2 PSU
- 3 Soft Touch Key/IR PCB
- 4 Timing controller
- 5 LED Driver

[Cables]

- 1 Main / PSU cable
- 2 Main / Module LVDS cable
- 3 LED driver / Module cable
- 4 SPK cable
- 5 Soft Touch key/IR cable
- 6 LED driver / PSU cable 14P

LCD Module

37LV3400

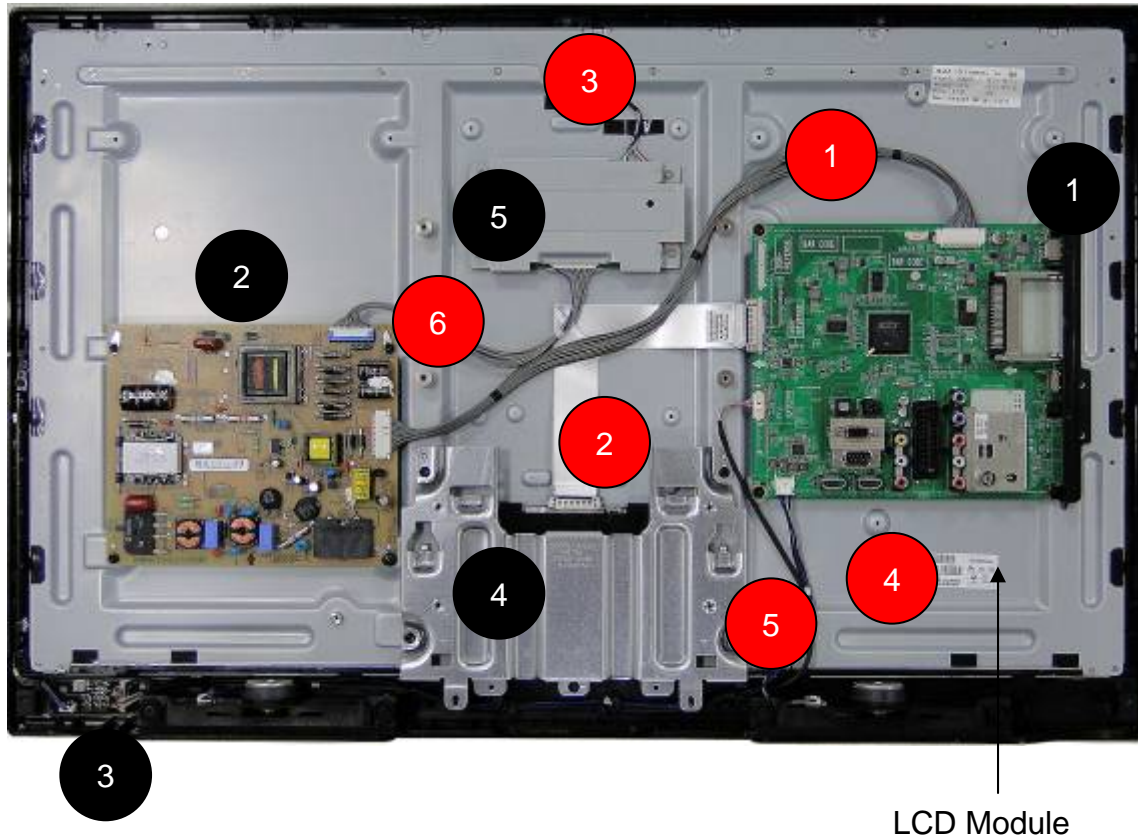

[PCBs]

- 1 Main PCB
- 2 PSU
- 3 Soft Touch Key/IR PCB
- 4 Timing controller
- 5 LED Driver

[Cables]

- 1 Main / PSU cable
- 2 Main / Module LVDS cable
- 3 LED driver / Module cable
- 4 SPK cable
- 5 Soft Touch key/IR cable
- 6 LED driver / PSU cable 14P

LCD Module



37LV3550

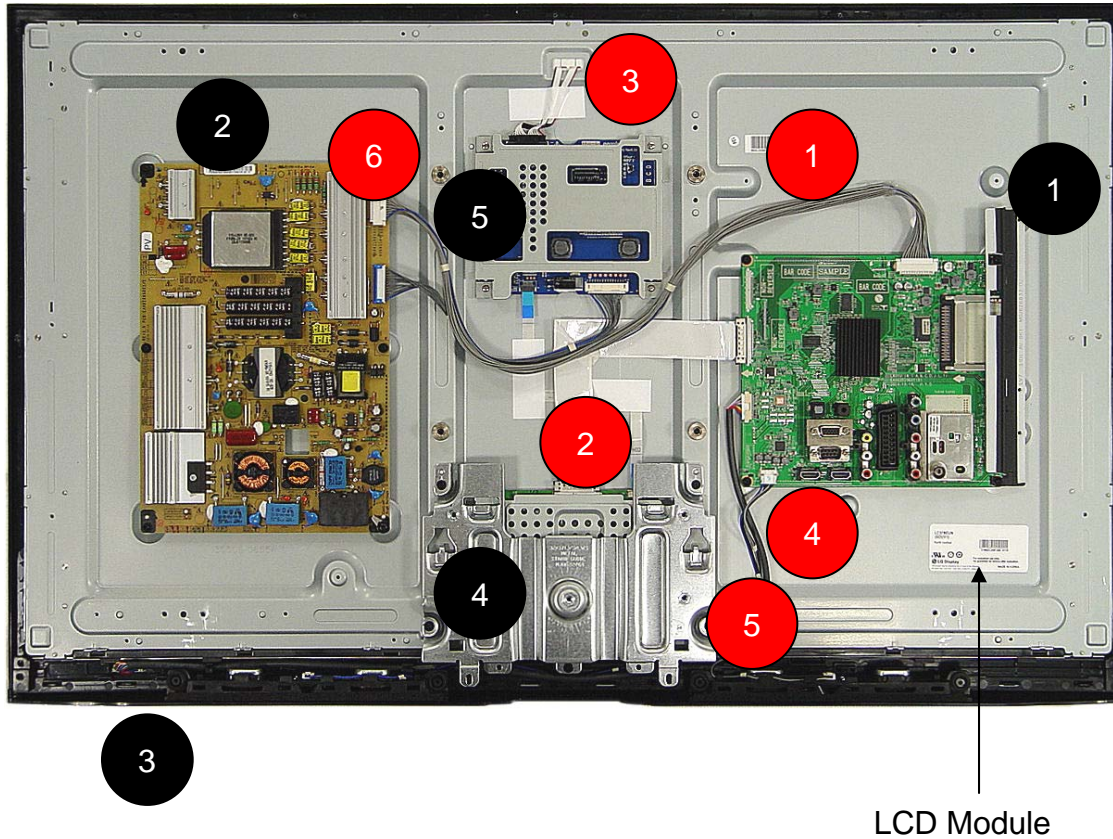

[PCBs]

- 1 Main PCB
- 2 PSU
- 3 Soft Touch Key/IR PCB
- 4 Timing controller
- 5 LED Driver

[Cables]

- 1 Main / PSU cable
- 2 Main / Module LVDS cable
- 3 LED driver / Module cable
- 4 SPK cable
- 5 Soft Touch key/IR cable
- 6 LED driver / PSU cable 14P

42LV4500

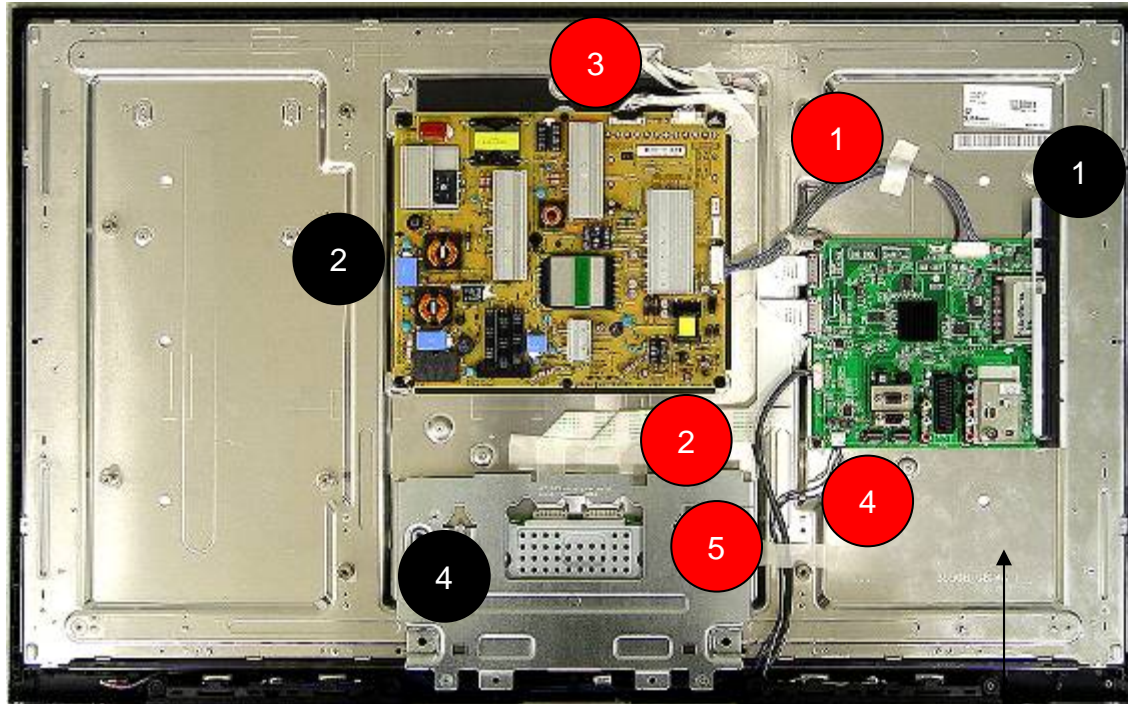

LCD Module

[PCBs]

- 1 Main PCB
- 2 PSU + LED driver
- 3 Soft Touch Key/IR PCB
- 4 Timing controller

[Cables]

- 1 Main / PSU cable
- 2 Main / Module LVDS cable
- 3 LED driver / Module cable
- 4 SPK cable
- 5 Soft Touch key/IR cable

42LW4500

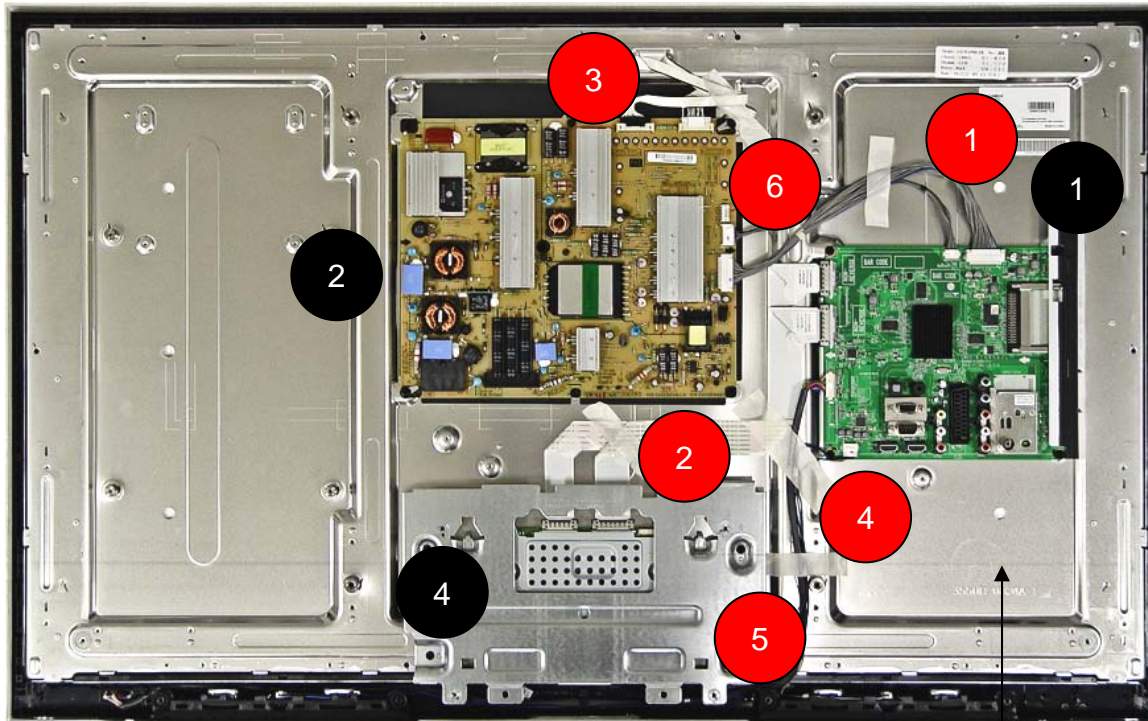

[PCBs]

- 1 Main PCB
- 2 PSU + LED driver
- 3 Soft Touch Key/IR PCB
- 4 Timing controller

[Cables]

- 1 Main / PSU cable
- 2 Main / Module LVDS cable
- 3 LED driver / Module cable
- 4 SPK cable
- 5 Soft Touch key/IR cable
- 6 Local dimming signal cable (Main / LED driver 8pin)

LCD Module



32LK530

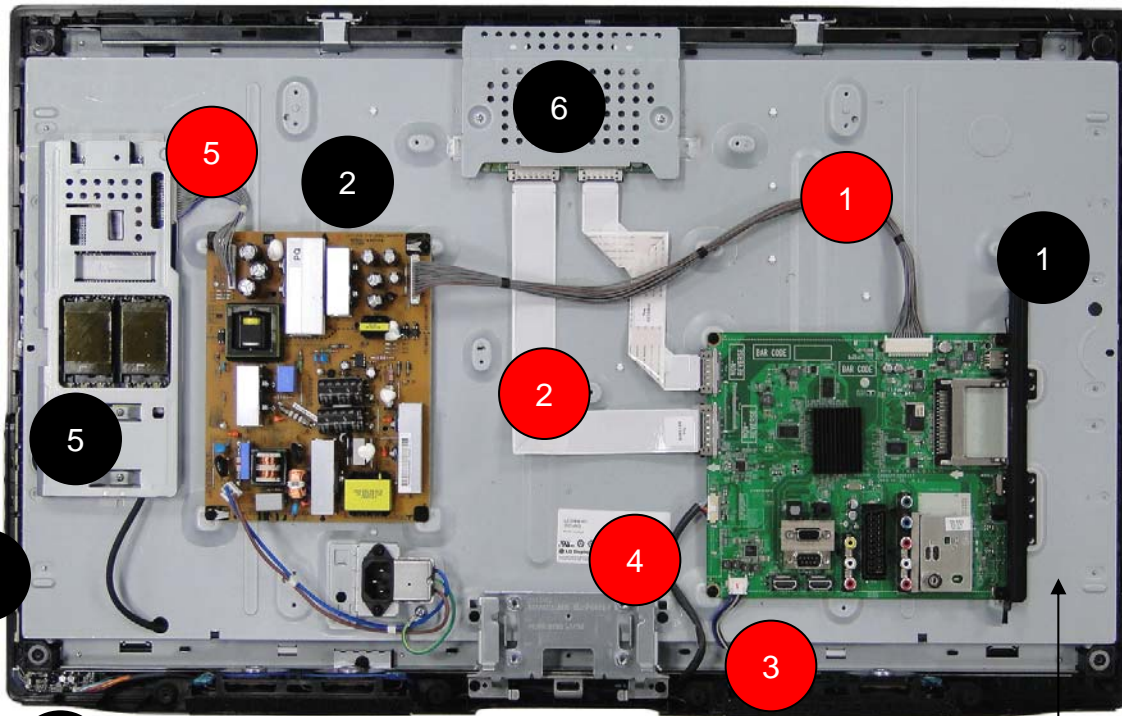

[PCBs]

- 1 Main PCB
- 2 PSU (without inverter)
- 3 IR & Indicator PCB
- 4 Local Key PCB
- 5 Inverter
- 6 Timing controller

[Cables]

- 1 Main / PSU cable
- 2 Main / Module LVDS cable
- 3 SPK cable
- 4 IR/Local key cable
- 5 Inverter/PSU cable (14pin)

LCD Module



37LK430

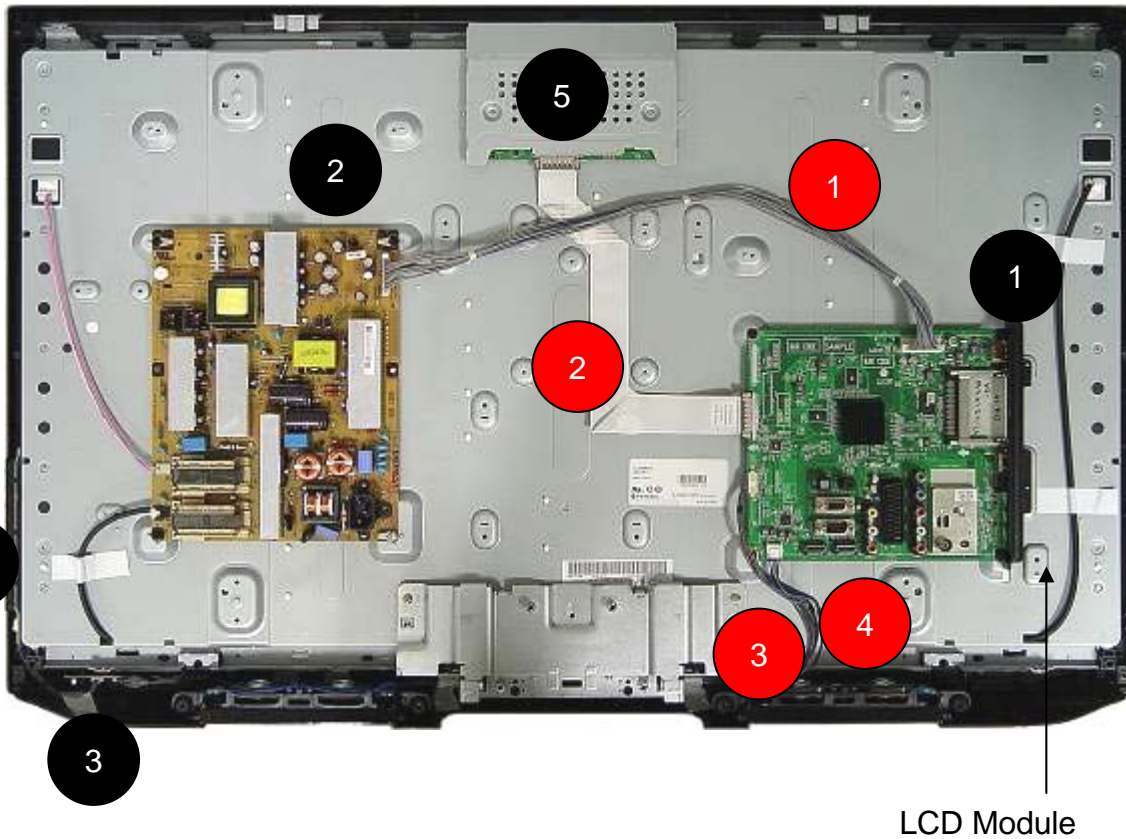

[PCBs]

- 1 Main PCB
- 2 PSU (without inverter)
- 3 IR & Indicator PCB
- 4 Local Key PCB
- 5 Timing controller

[Cables]

- 1 Main / PSU cable
- 2 Main / Module LVDS cable
- 3 SPK cable
- 4 IR/Local key cable

LCD Module



42LK450

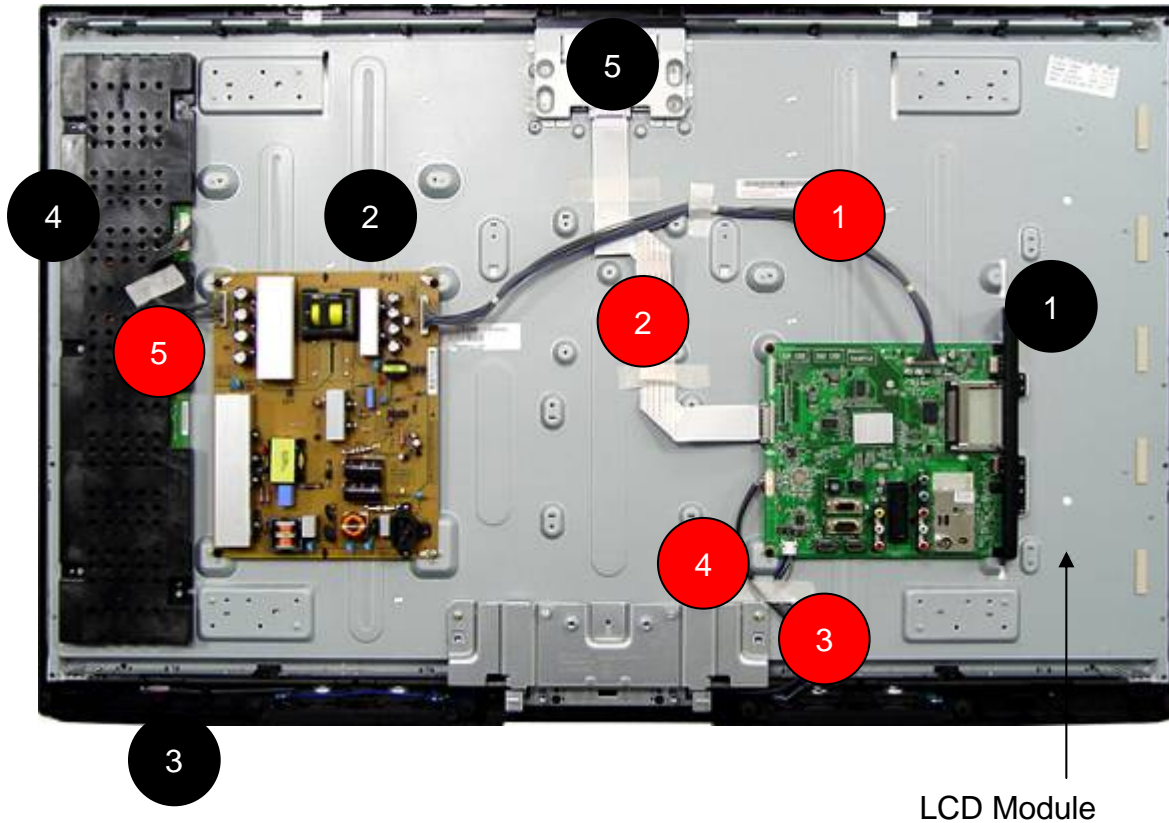

[PCBs]

- 1 Main PCB
- 2 PSU (without inverter)
- 3 Soft Touch Key/IR PCB
- 4 Inverter
- 5 Timing controller

[Cables]

- 1 Main / PSU cable
- 2 Main / Module LVDS cable
- 3 SPK cable
- 4 Soft Touch key/IR cable
- 5 Inverter/PSU cable (14pin)

LCD Module

Interconnection – sub PCB(LV**/LK450 Series)

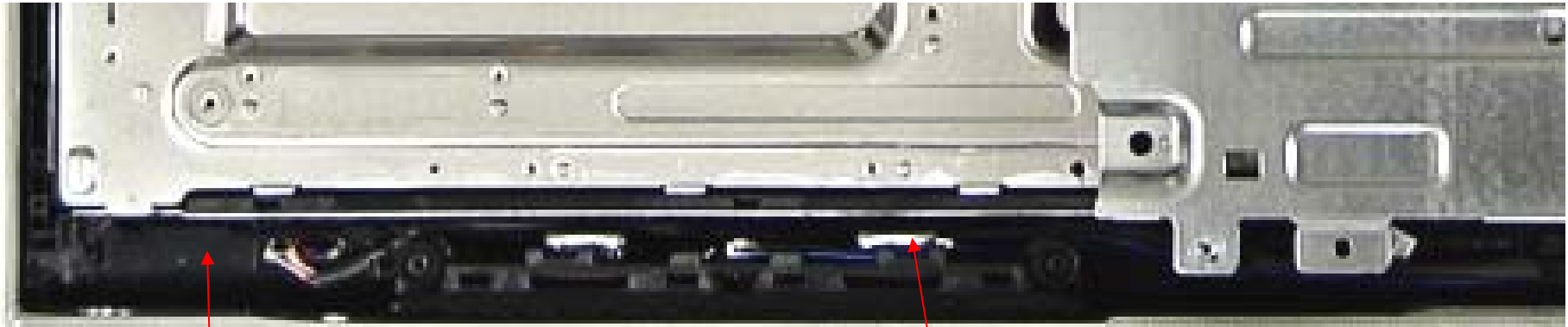

SPK unit

Soft Touch Key/IR PCB



15pin Cable

To Main

Interconnection – sub PCB(LK430/LK530 Series)



Tact key

IR/Sensor

SPK unit

12pin Cable

To Main

Contents of LCD TV Standard Repair Process

No.	Error symptom (High category)	Error symptom (Mid category)	Page	Remarks
1	A. Video error	No video/Normal audio	1	
2		No video/No audio	2	
3		Video error, video lag/stop	3	
4		Color error	4	
5		Vertical/Horizontal bar, residual image, light spot, external device color error	5	
6	B. Power error	No power	6	
7		Off when on, off while viewing, power auto on/off	7	
8	C. Audio error	No audio/Normal video	8	
9		Wrecked audio/discontinuation/noise	9	
10	D. Function error	No response in remote controller, key error, recording error, memory error	10	
11		External device recognition error	11	
12	E. Noise	Circuit noise, mechanical noise	12	
13	F. Exterior error	Exterior defect	13	

First of all, Check whether there is SVC Bulletin in GCSC System for these model.

LCD TV	Error symptom	A. Video error	Established date	2010. 2 .19	
		No video/ Normal audio	Revised date		1/13

**First of all, Check whether all of cables between board is inserted properly or not.
(Main B/D↔ Power B/D, LVDS Cable,Speaker Cable,IR B/D Cable,,)**

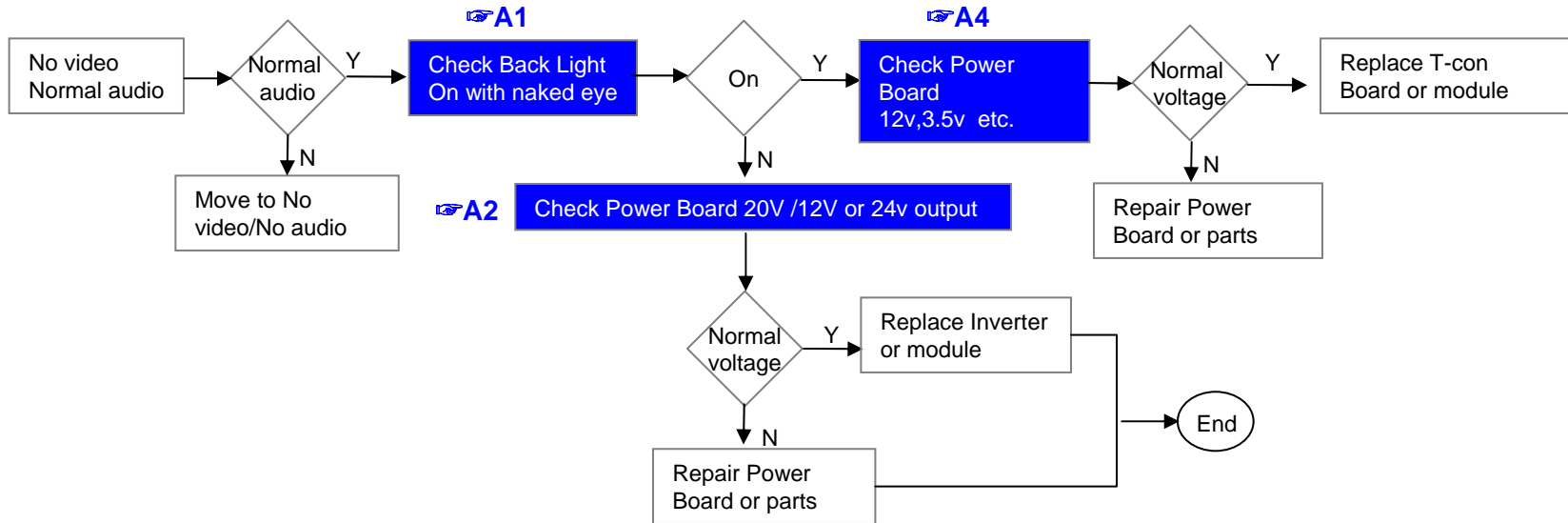

※Precaution A7 & A3



LCD TV	Error symptom	A. Video error	Established date	2010. 2 .19	
		No video/ No audio	Revised date		2/13

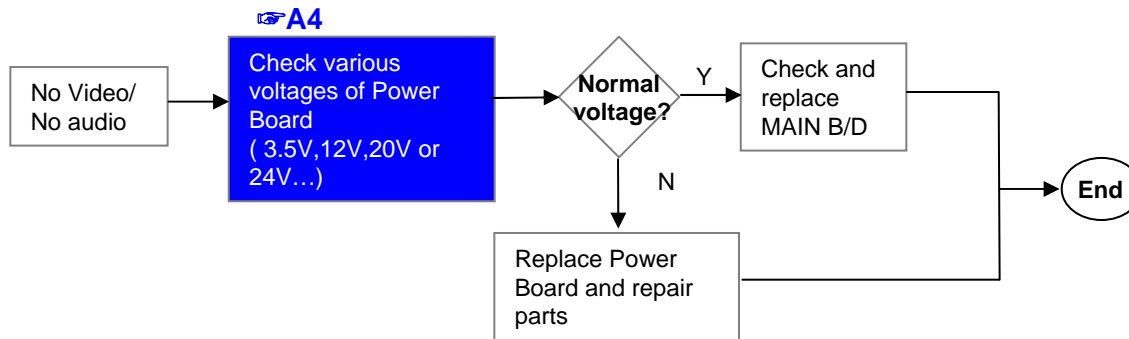

LCD TV	Error symptom	A. Picture Problem	Established date	2010. 2 .19	
		Picture broken/ Freezing	Revised date		3/13

A6

Check RF Signal level

- . By using Digital signal level meter
- . By using Diagnostics menu on OSD
(Menu→Red key→Signal test)
- Signal strength (Normal : over 50%)
- Signal Quality (Normal: over 50%)

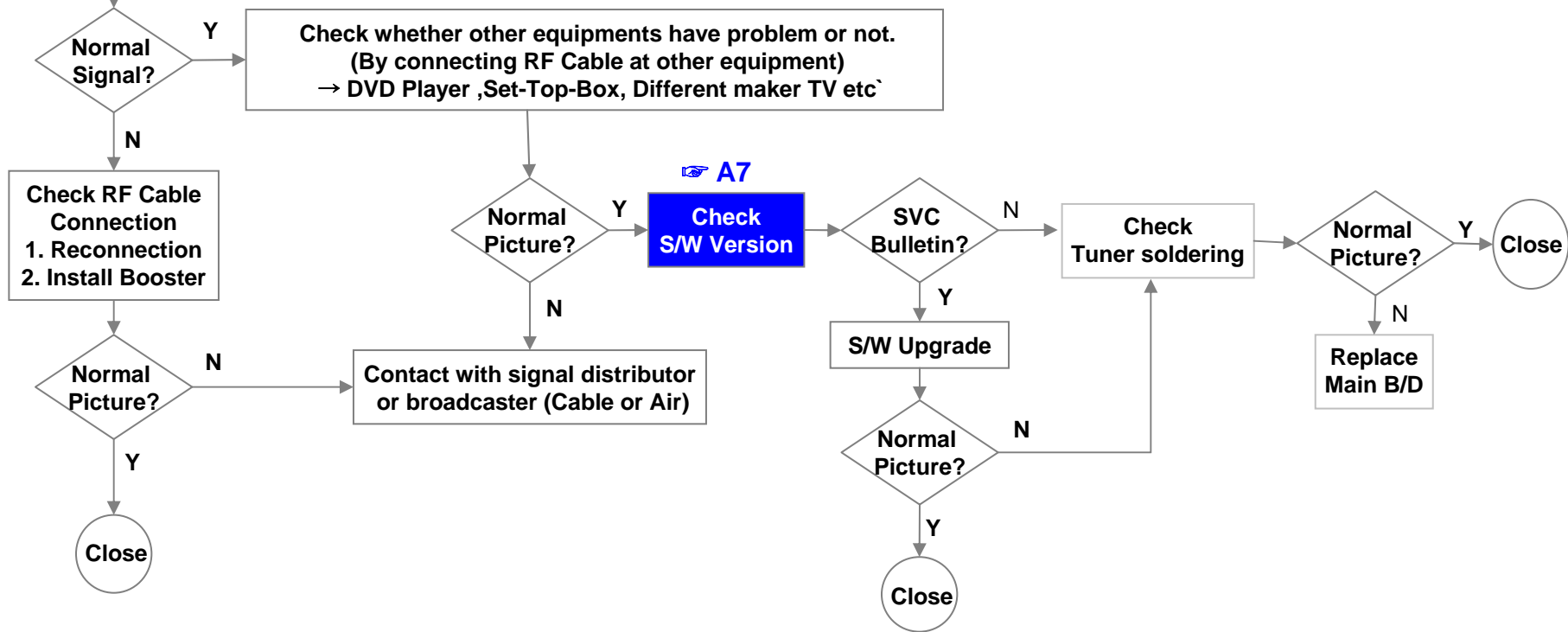

LCD TV	Error symptom	A. Video error	Established date	2010. 2 .19	
		Color error	Revised date		4/13

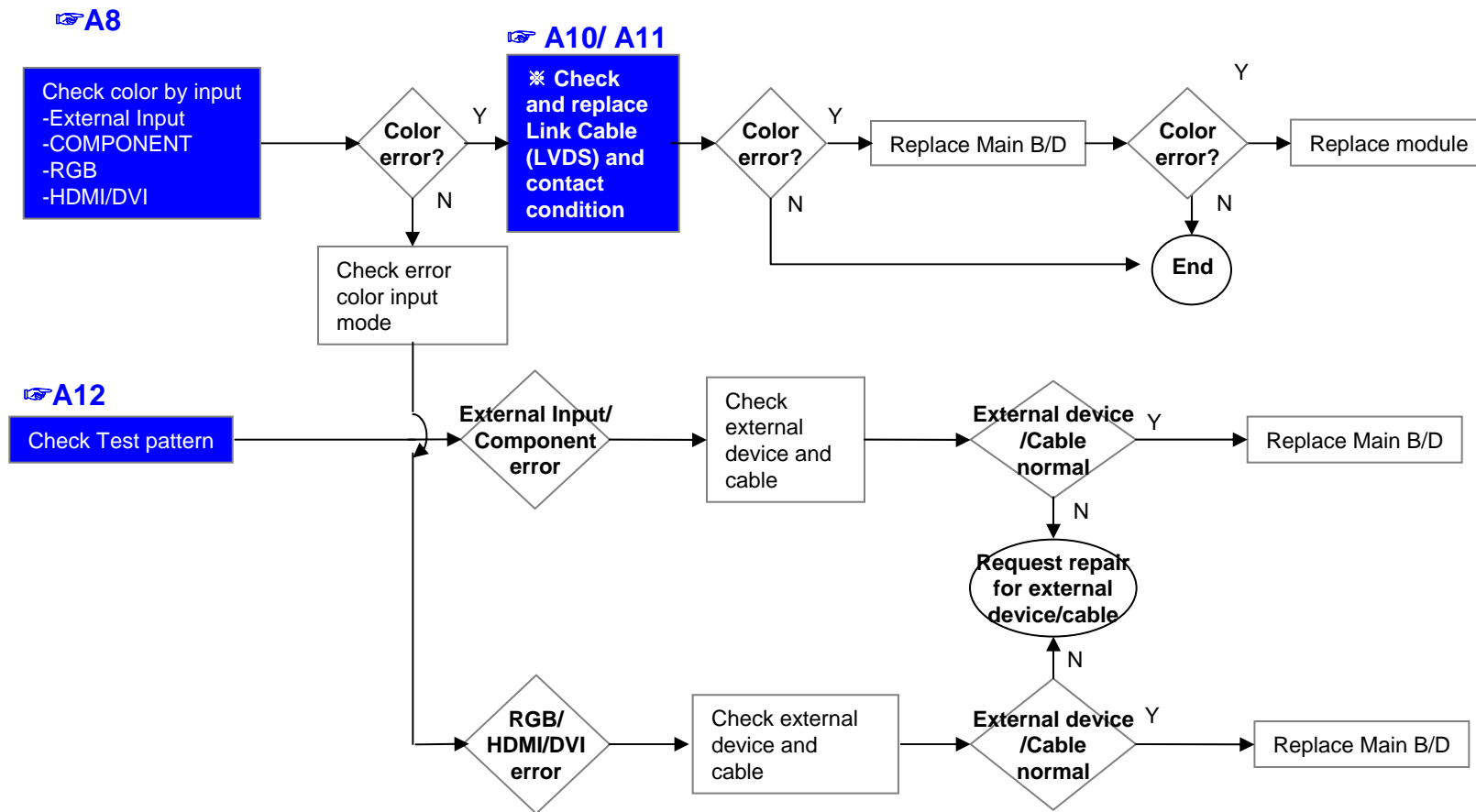

LCD TV	Error symptom	A. Video error	Established date	2010. 2 .19	
		Vertical / Horizontal bar, residual image, light spot, external device color error	Revised date		5/13

Vertical/Horizontal bar, residual image, light spot

A8

Check color condition by input
 -External Input
 -Component
 -RGB
 -HDMI/DVI

A12

Check Test pattern

A10/ A11

Check and replace Link Cable

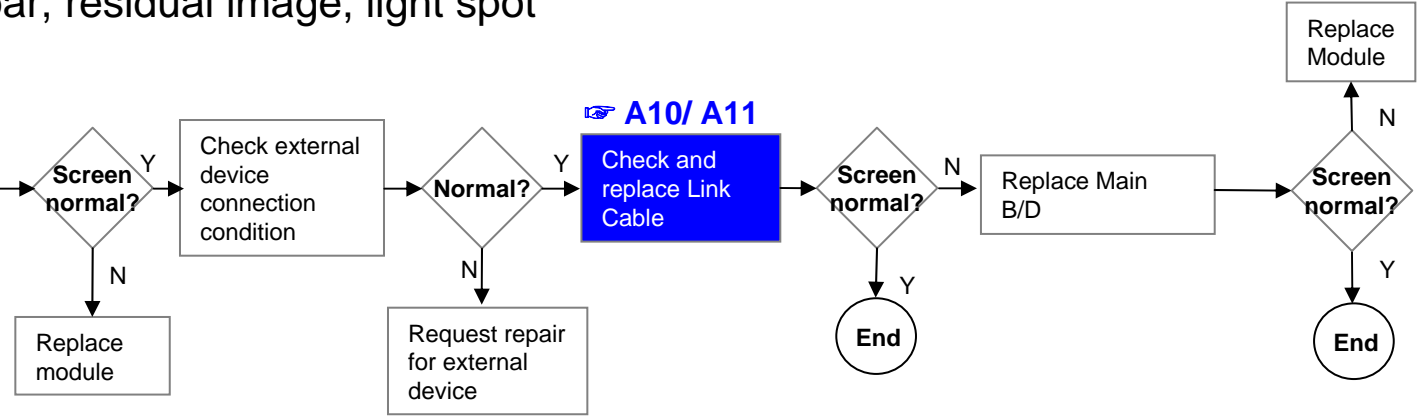

External device screen error-Color error

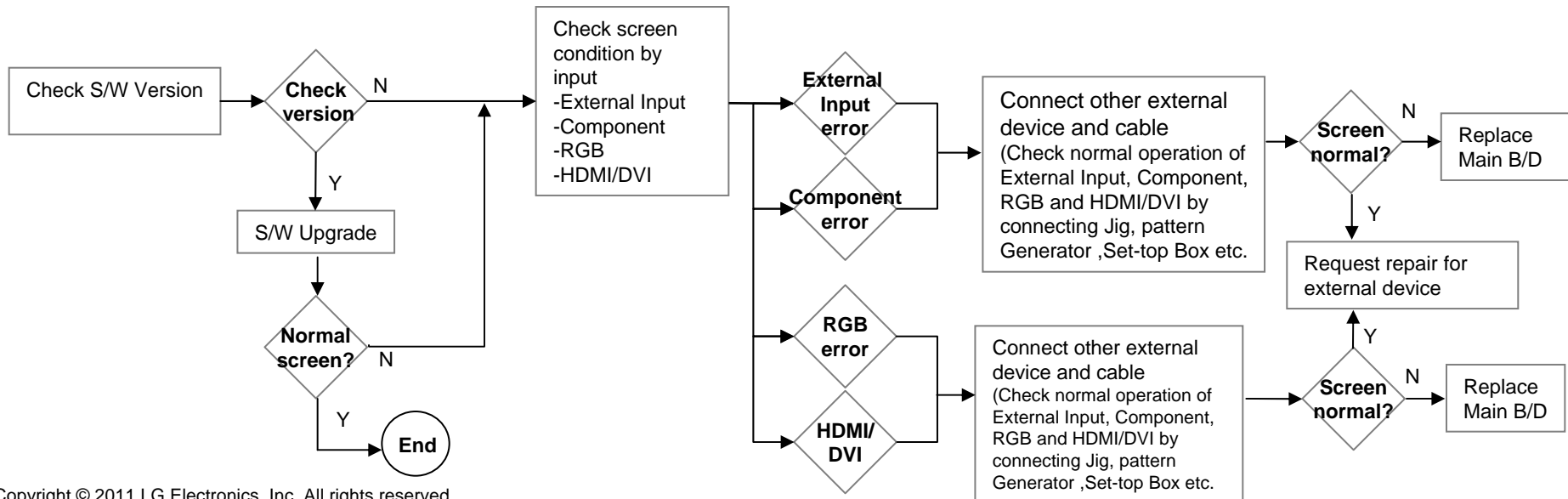

LCD TV	Error symptom	B. Power error	Established date	2010. 2 .19	
		No power	Revised date		6/13

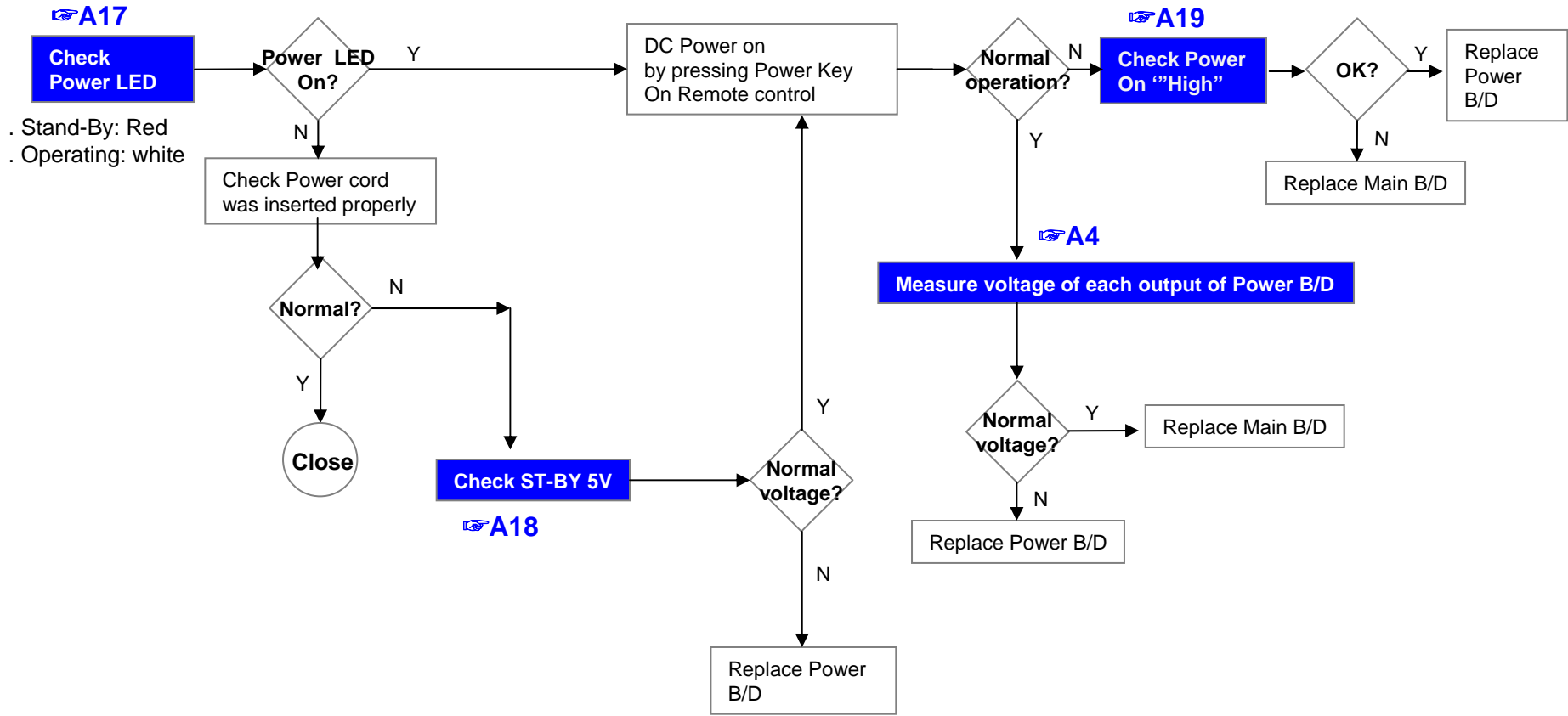

LCD TV	Error symptom	B. Power error	Established date	2010. 2 .19	
		Off when on, off while viewing, power auto on/off	Revised date		7/13

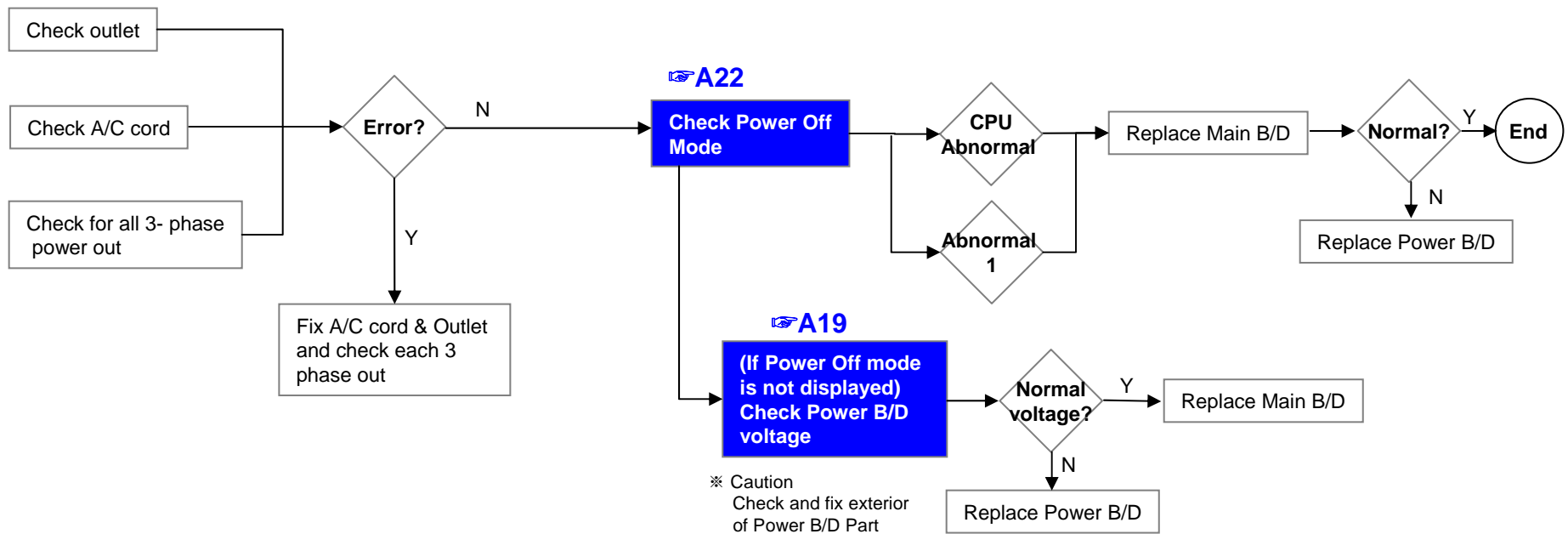

* Please refer to the all cases which can be displayed on power off mode.

Status	Power off List	Explanation
Normal	"POWEROFF_REMOTEKEY"	Power off by REMOTE CONTROL
	"POWEROFF_OFFTIMER"	Power off by OFF TIMER
	"POWEROFF_SLEEPTIMER"	Power off by SLEEP TIMER
	"POWEROFF_INSTOP"	Power off by INSTOP KEY
	"POWEROFF_AUTOOFF"	Power off by AUTO OFF
	"POWEROFF_ONTIMER"	Power off by ON TIMER
	"POWEROFF_RS232C"	Power off by RS232C
	"POWEROFF_RESREC"	Power off by Reserved Record
	"POWEROFF_RECEND"	Power off by End of Recording
	"POWEROFF_SWDOWN"	Power off by S/W Download
	"POWEROFF_UNKNOWN"	Power off by unknown status except listed case
Abnormal	"POWEROFF_ABNORMAL1"	Power off by abnormal status except CPU trouble
	"POWEROFF_CPUABNORMAL"	Power off by CPU Abnormal

LCD TV	Error symptom	C. Audio error	Established date	2010. 2 .19	
		No audio/ Normal video	Revised date		8/13

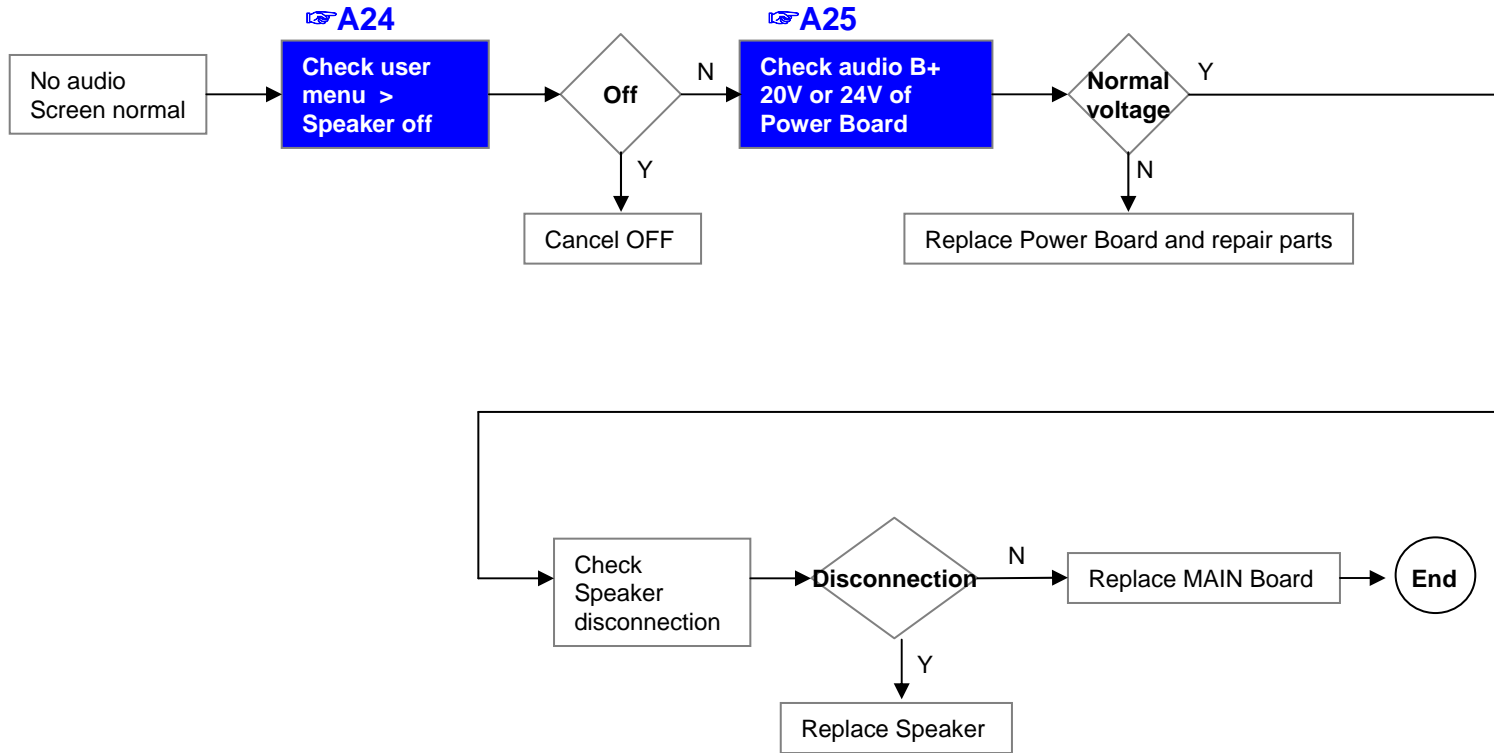

LCD TV	Error symptom	C. Audio error	Established date	2010. 2 .19
		Wrecked audio/ discontinuation/noise	Revised date	9/13

→ abnormal audio/discontinuation/noise is same after “Check input signal” compared to No audio

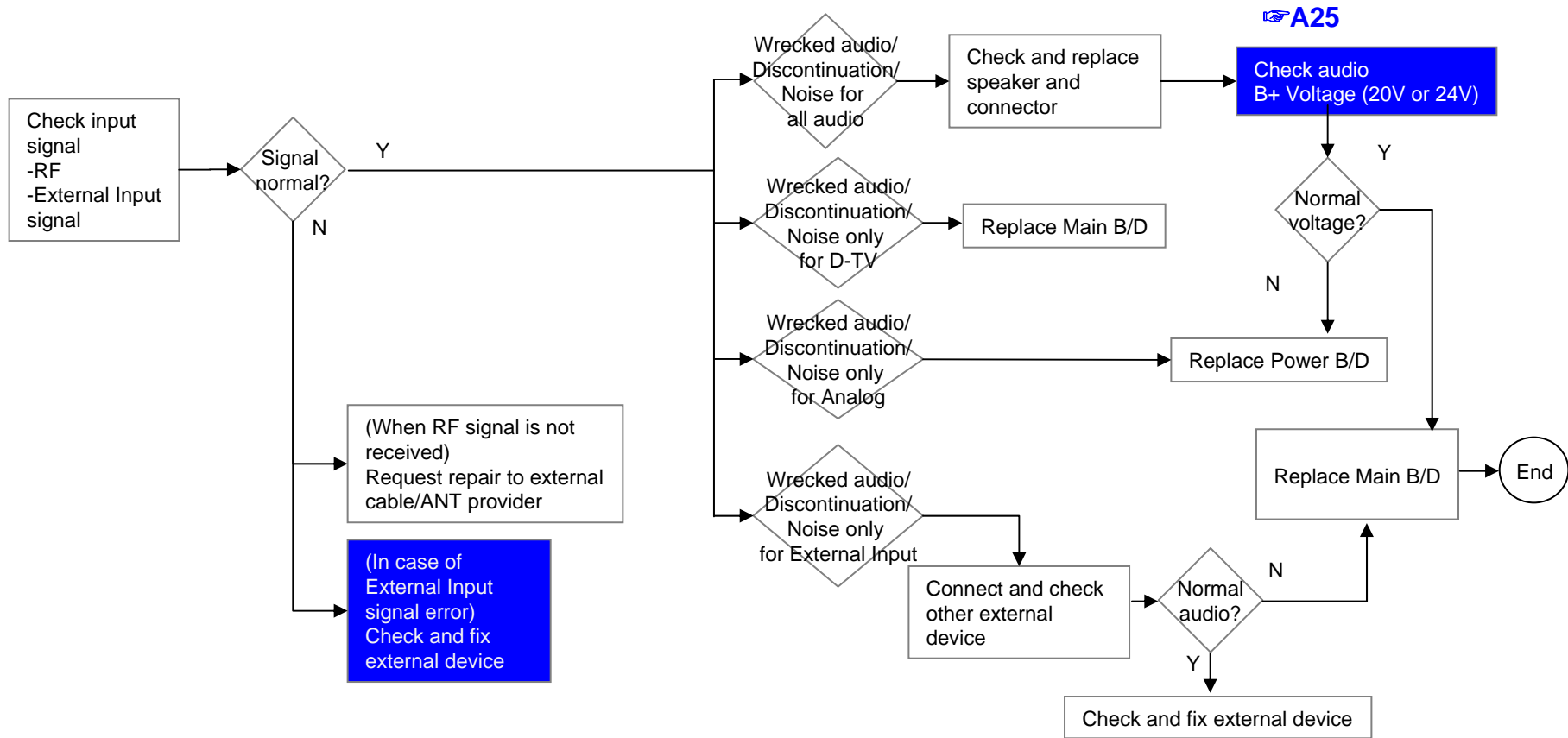

A25

Check audio B+ Voltage (20V or 24V)

**(In case of External Input signal error)
Check and fix external device**

LCD TV	Error symptom	D. General Function Problem	Established date	2010. 2 .19	
		Remote control & Local switch checking	Revised date		10/13

1. Remote control(R/C) operating error

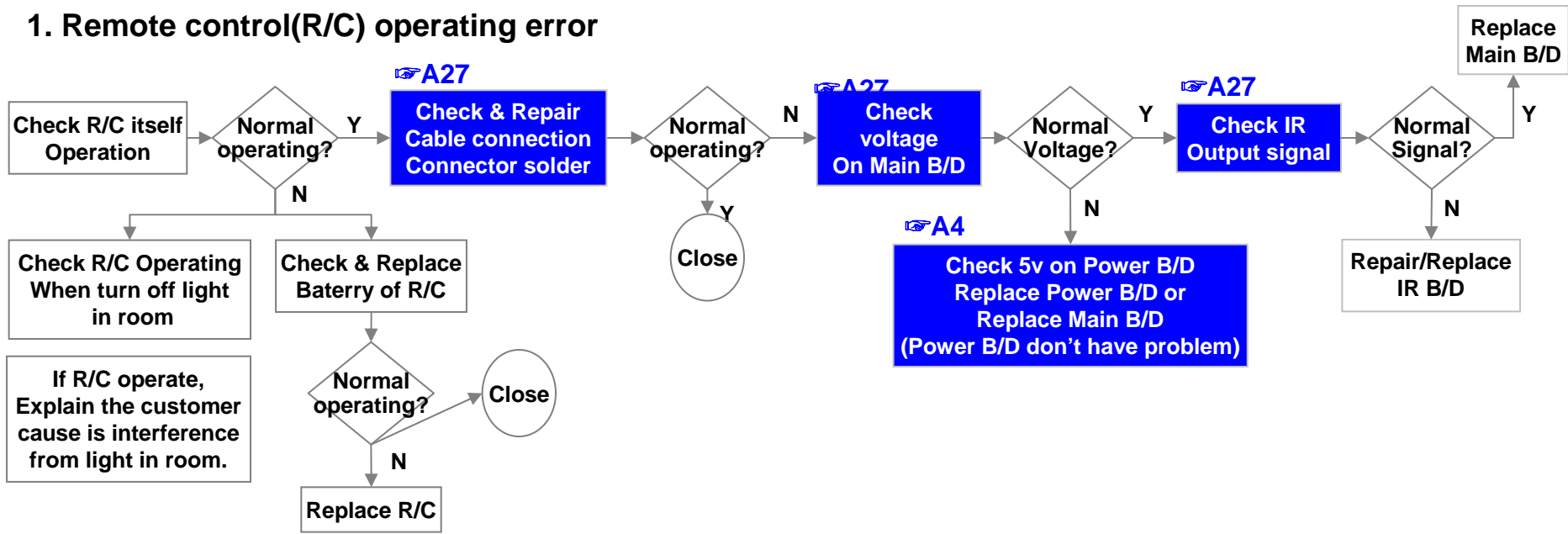

LCD TV	Error symptom	D. Function error	Established date	2010. 2 .19	
		External device recognition error	Revised date		11/13

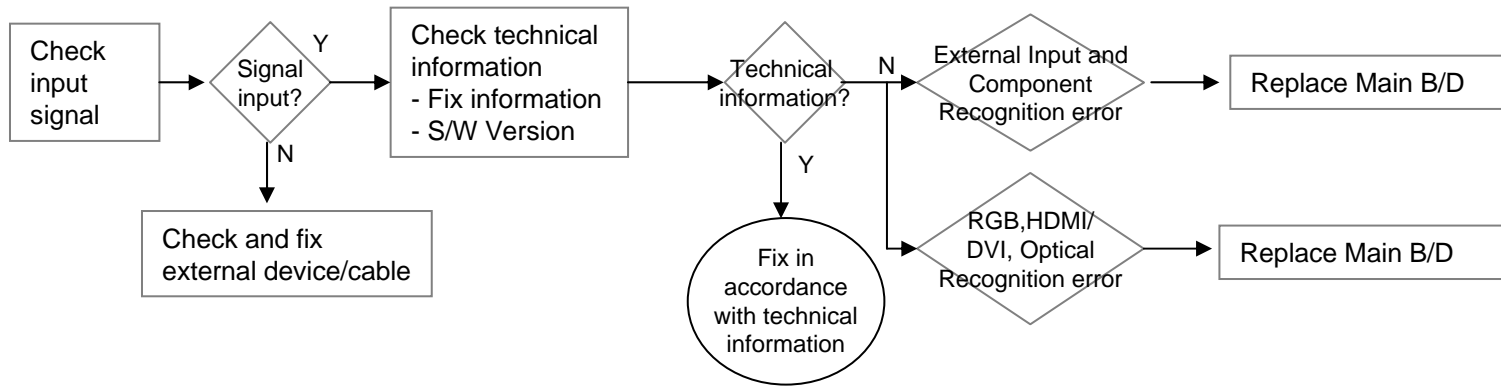

LCD TV	Error symptom	E. Noise	Established date	2010. 2 .19	
		Circuit noise, mechanical noise	Revised date		12/13

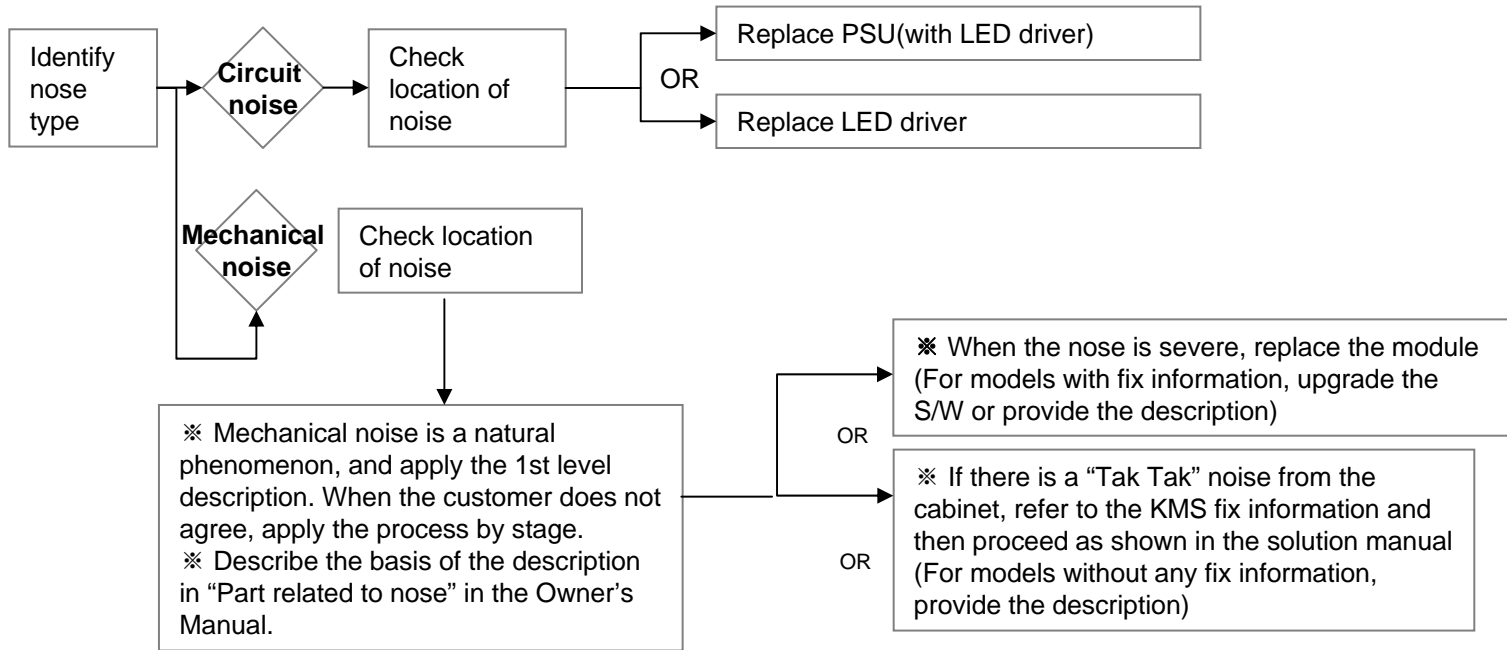

LCD TV	Error symptom	F. Exterior defect	Established date	2010. 2 .19	
		Exterior defect	Revised date		13/13

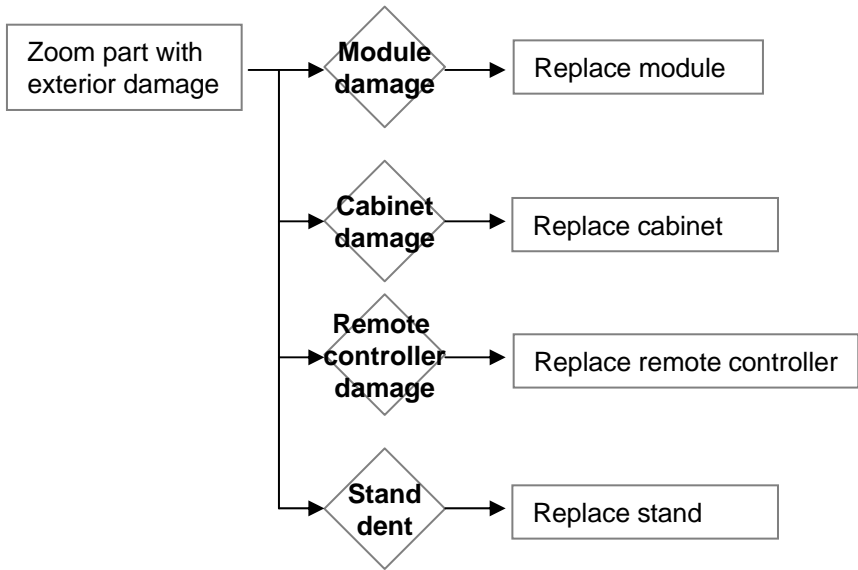

Contents of LCD TV Standard Repair Process Detail Technical Manual

No.	Error symptom	Content	Page	Remarks
1	A. Video error_ No video/Normal audio	Check LCD back light with naked eye	A1	
2		LED driver B+ 24V measuring method	A2	
3		Check White Balance value	A3	
4		Power Board voltage measuring method	A4	
6	A. Video error_ No video/Video lag/stop	TUNER input signal strength checking method	A6	
7		LCD-TV Version checking method	A7	
9	A. Video error_Color error	LCD TV connection diagram	A8	
10		Tuner Checking Part	A9	
11		Check Link Cable (LVDS) reconnection condition	A10 A11	A10 : Edge LED A11 : Lamp
12		Adjustment Test pattern - ADJ Key	A12	
13	A. Video error_Vertical/Horizontal bar, residual image, light spot	LCD TV connection diagram	A8	
14		Check Link Cable (LVDS) reconnection condition	A10 A11	A10 : Edge LED A11 : Lamp
15		Adjustment Test pattern - ADJ Key	A12	
16	<Appendix> Defected Type caused by T-Con/ Inverter/ Module	Exchange T-Con Board (1)	A-1/5	
17		Exchange T-Con Board (2)	A-2/5	
18		Exchange LED driver Board (PSU)	A-3/5	
19		Exchange Module itself (1)	A-4/5	
20		Exchange Module itself (2)	A-5/5	

Continue to the next page

LGE Internal Use Only

Contents of LCD TV Standard Repair Process Detail Technical Manual

Continued from previous page

No.	Error symptom	Content	Page	Remarks
21	B. Power error_No power	Check front display LED	A17	
22		Check power input Voltage & ST-BY 5V	A18	
23		Checking method when power is ON	A19	
24		POWER BOARD voltage measuring method	A4	
25				
26	B. Power error_Off when on, off while viewing	POWER OFF MODE checking method	A22	
27	B. Power error_Off when on, off while viewing	POWER BOARD PIN voltage checking method	A19	
28	C. Audio error_No audio/Normal video	Checking method in menu when there is no audio	A24	
29		Voltage and speaker checking method when there is no audio	A25	
30	C. Audio error_Wrecked audio/discontinuation	Voltage and speaker checking method in case of audio error	A25	
31	D. Function error_ No response in remote controller, key error	Remote controller operation checking method	A27	

Standard Repair Process Detail Technical Manual

LCD TV	Error symptom	A. Video error_No video/Normal audio	Established date	2011. 2 .07	
	Content	Check LCD back light with naked eye	Revised date		A1

<ALL MODELS>

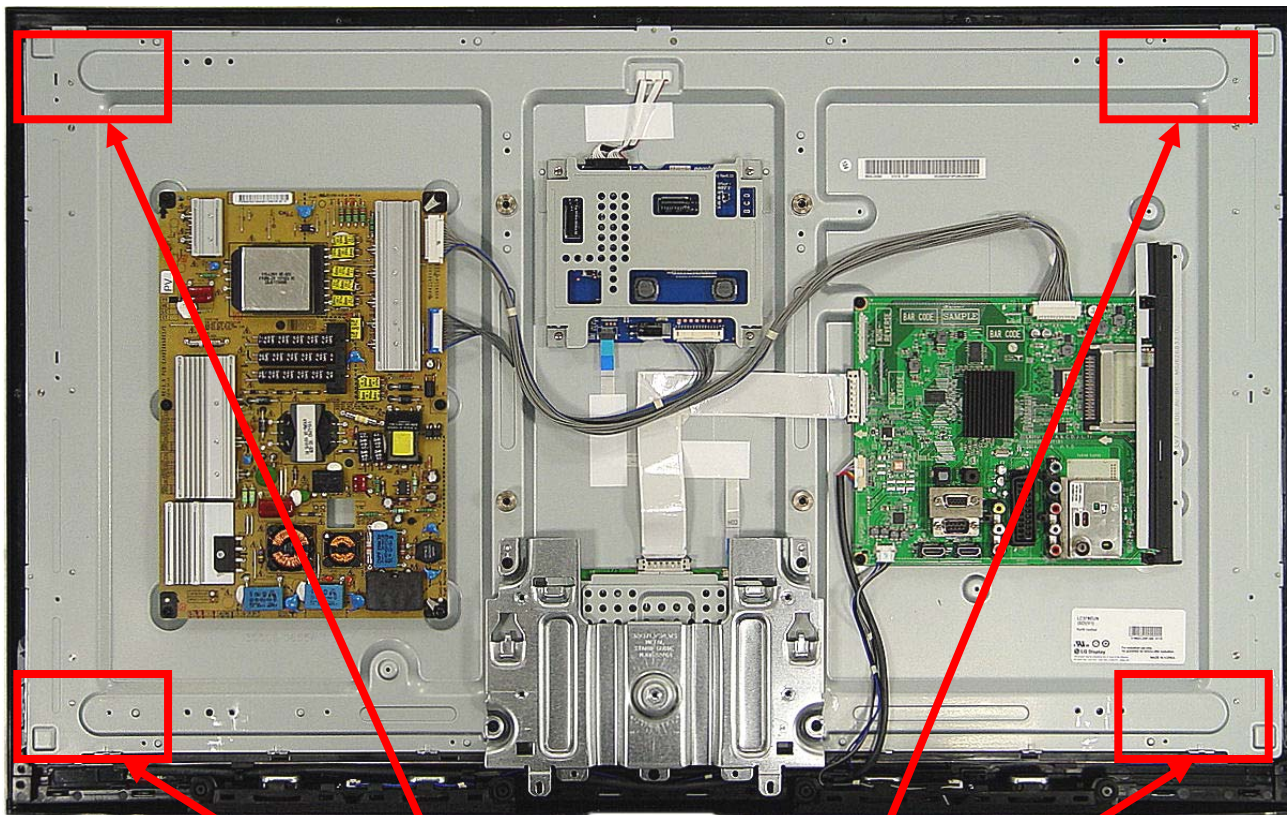

After turning on the power and disassembling the case, check with the naked eye, whether you can see light from 4 locations.

Standard Repair Process Detail Technical Manual

LCD TV	Error symptom	A. Video error_No video/Normal audio	Established date	2011. 2 .07	
	Content	LED driver/lamp inverter B+ 24V measuring method	Revised date		A2

Check the DC 24V, 12V, 3.5V and Inverter on

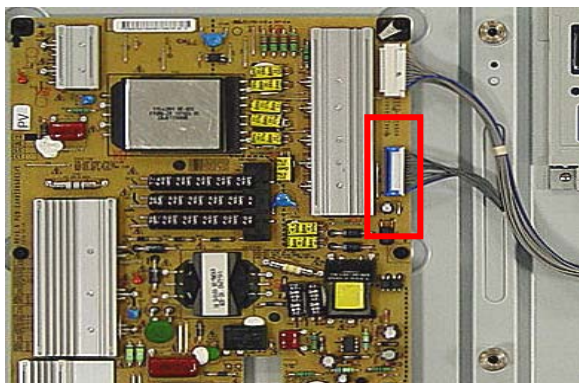

Edge LED PSU without LED Driver

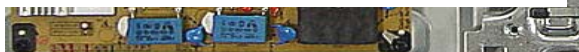

* ALEF/OS 42/47/55"/60"

Power Board ↔ Drive Board – PSU		
	14 pin	14 pin
1 ~ 5	24V	24V
6 ~ 10	GND	GND
11	Detect	Detect
12	Inverter On/Off	Inverter On/Off
13	Int. PWM	Int. PWM
14	Ext. PWM (PDIM)	Ext. PWM (PDIM)

* ALL 32"/37"

14 Pin (Power Board ↔ Driver) PSU	
1 ~ 5	24V
6 ~ 10	GND
11	Detect
12	Inverter On/Off
13	Int. PWM
14	Ext. PWM (PDIM)

* 26" ~ 47" : 11 Pin map

Lamp (Power Board ↔ Inverter) - PSU	
	14 Pin
1 ~ 5	24V
6 ~ 10	GND
11	Detect
12	Inverter On/Off
13	Int. PWM
14	Ext. PWM (PDIM)

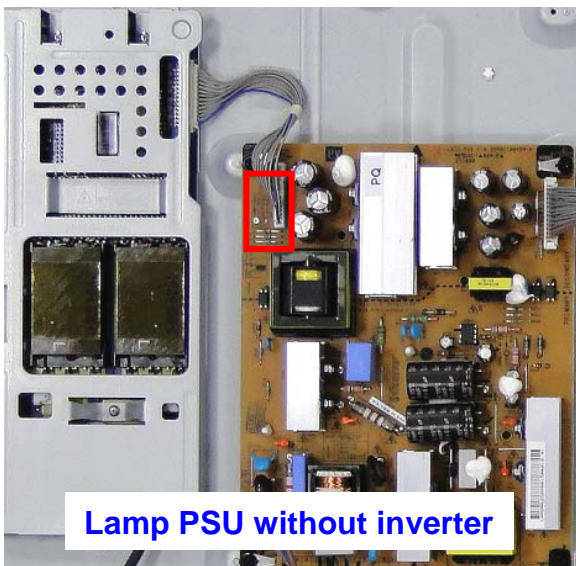

Lamp PSU without inverter

Standard Repair Process Detail Technical Manual

LCD TV	Error symptom	A. Video error_No video/Normal audio	Established date	2011. 2 .07	
	Content	Check White Balance value	Revised date		A3

<ALL MODELS>

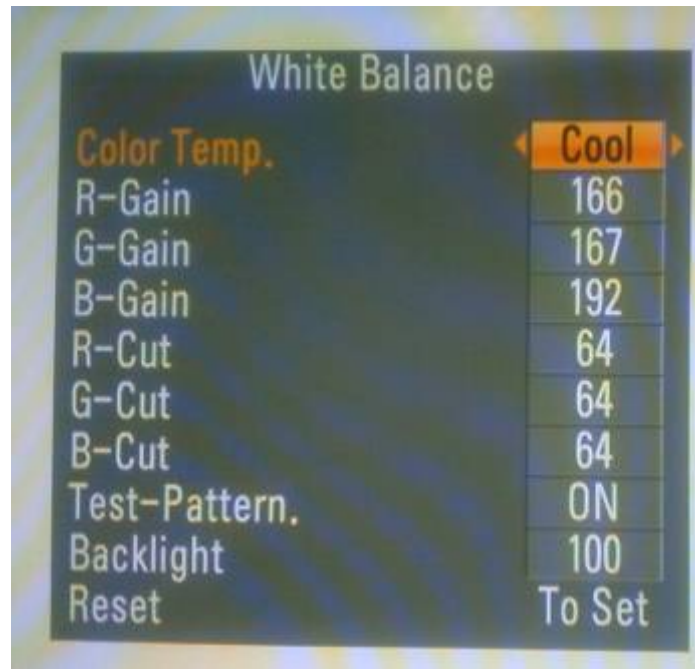
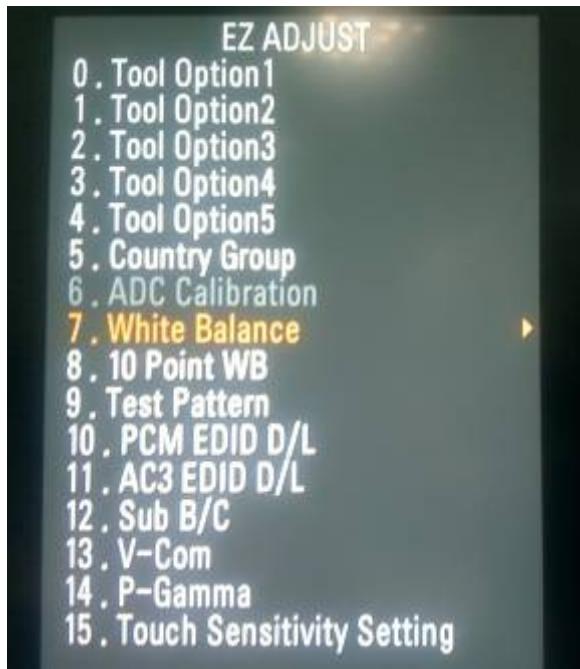

Entry method

1. Press the ADJ button on the remote controller for adjustment.
2. Enter into White Balance of item 7.
3. After recording the R, G, B (GAIN, Cut) value of Color Temp (Cool/Medium/Warm), re-enter the value after replacing the MAIN BOARD.

Standard Repair Process Detail Technical Manual

LCD TV	Error symptom	A. Video error_No video/ Audio	Established date	2011. 2 .07	
	Content	Power Board voltage measuring method	Revised date		A4

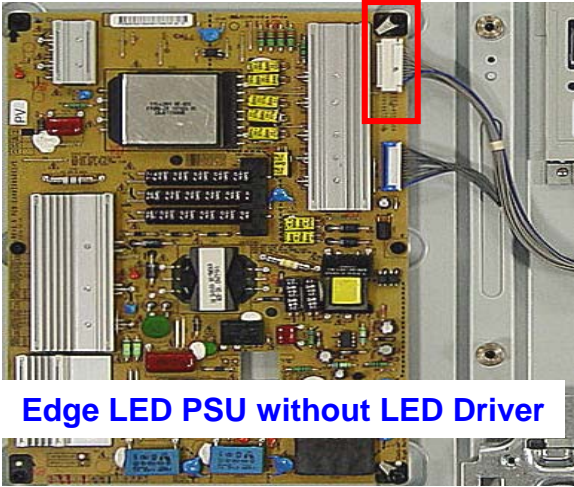

Edge LED PSU without LED Driver

Check the DC 20Vor24V, 12V, 3.5V.

24 Pin (Power Board ↔ Main Board) - 공통			
SMAW200-H24S (YEONHO)			
1	Power on	2	20V (24V)
3	20V (24V)	4	20V (24V)
5	GND	6	GND
7	GND	8	GND
9	3.5V	10	3.5V
11	3.5V	12	3.5V
13	GND	14	GND
15	GND	16	N.C
17	12V	18	Inverter On/off
19	12V	20	Lamp : A-Dim LED : N.C
21	12V	22	PWM Dim #1
23	N.C	24	Error-out

• Lamp SCANNING Model : PWM Dim #2

24 Pin (Power Board ↔ Main Board)			
FW20020-24SB (FOOSUNG)			
1	Power on	2	20V (24V)
3	20V (24V)	4	20V (24V)
5	GND	6	GND
7	GND	8	GND
9	3.5V	10	3.5V
11	3.5V	12	3.5V
13	GND	14	GND
15	GND	16	GND
17	12V	18	Inverter On/off
19	12V	20	Lamp : A-Dim
21	12V	22	PWM Dim #1
23	N.C	24	Error-out

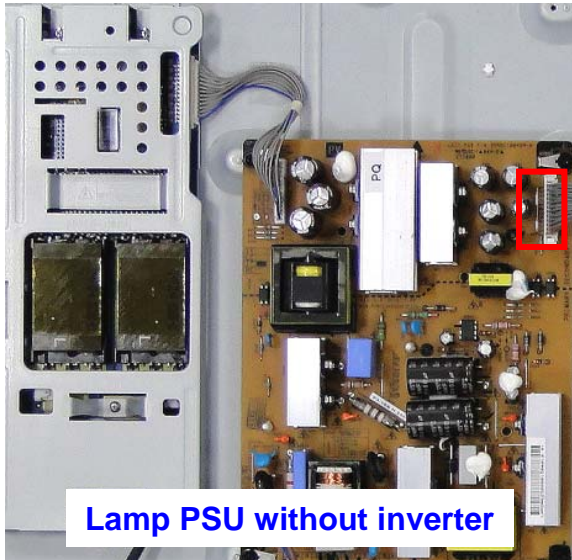

Lamp PSU without inverter

Standard Repair Process Detail Technical Manual

LCD TV	Error symptom	A. Video error_Video error, video lag/stop	Established date	2011. 2 .07	
	Content	TUNER input signal strength checking method	Revised date		A6

<ALL MODELS>

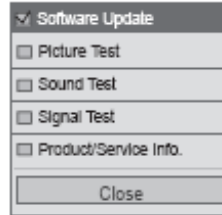

MENU -> red key(customer support -> signal test -> select channel

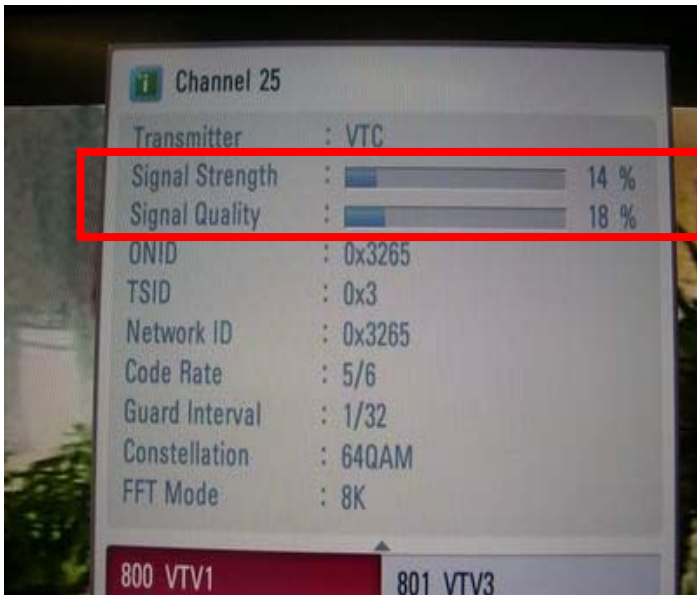

When the signal is strong, use the attenuator (-10dB, -15dB, -20dB etc.)



Standard Repair Process Detail Technical Manual

LCD TV	Error symptom	A. Video error_Video error, video lag/stop	Established date	2011. 2 .07	
	Content	LCD-TV Version checking method	Revised date		A7

<ALL MODELS>

1. Checking method for remote controller for adjustment



Version

Press the IN-START with the remote controller for adjustment

Standard Repair Process Detail Technical Manual

LCD TV	Error symptom	A. Video error _ Vertical/Horizontal bar, residual image, light spot	Established date	2011. 2 .07	
	Content	LCD TV connection diagram (1)	Revised date		A8

• Image shown may differ from your TV.

Only 32/37/42LK45**, 32/42LK55**, 32LV25**, 32/42LV34**, 32/37/40/42/47LV35**, 32/37/42/47LV45**, 32/37/42/47/55LV45**

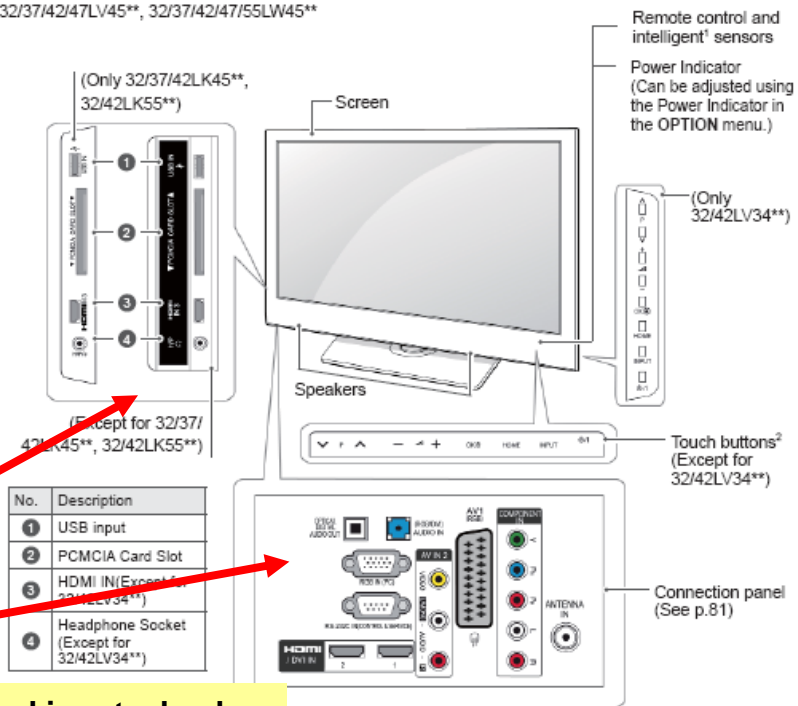

As the part connecting to the external input, check the screen condition by signal

Button	Description
▼ P ▲	Scrolls through the saved programmes
- ▸ +	Adjusts the volume level
OK	Selects the highlighted menu option or confirms an input
HOME	Accesses the main menus, or saves your input and exits the menus
INPUT	Changes the input source
⓪/I	Turns the power on or off

1 Intelligent sensor - Adjusts the image quality corresponding to the surrounding environment.

2. Touch Button - You can use the desired button function by touching.

Standard Repair Process Detail Technical Manual

LCD TV	Error symptom	A. Video error_Video error, video lag/stop	Established date	2011. 2 .07	
	Content	TUNER checking part	Revised date		A9

<ALL MODELS>



Checking method:

1. Check the signal strength or check whether the screen is normal when the external device is connected.
2. After measuring each voltage from power supply, finally replace the MAIN BOARD.

Standard Repair Process Detail Technical Manual

LCD TV	Error symptom	A. Video error_Color error	Established date	2011. 2 .07	
	Content	Check Link Cable (LVDS) reconnection condition	Revised date		A10

<LV** : Edge LED Series Models>

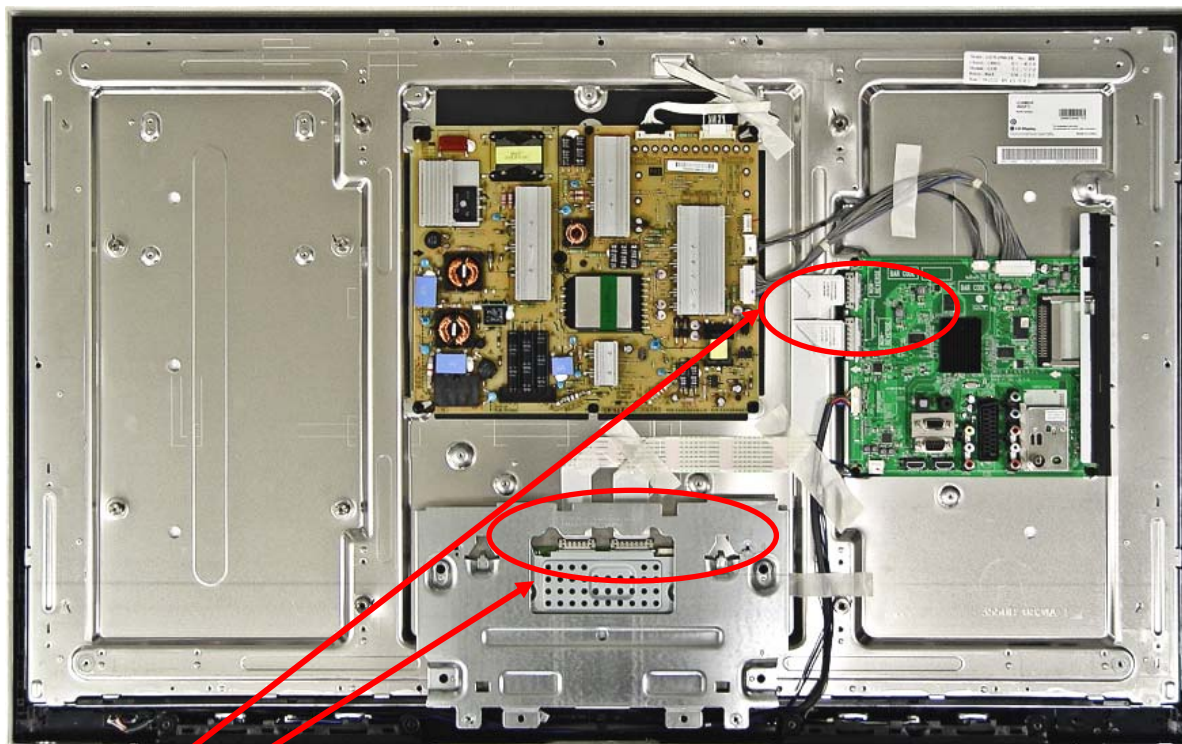

Check the contact condition of the Link Cable, especially dust or mis insertion.

Standard Repair Process Detail Technical Manual

LCD TV	Error symptom	A. Video error_Color error	Established date	2011. 2 .07	
	Content	Check Link Cable (LVDS) reconnection condition	Revised date		A11

<LK** : Lamp series Models>

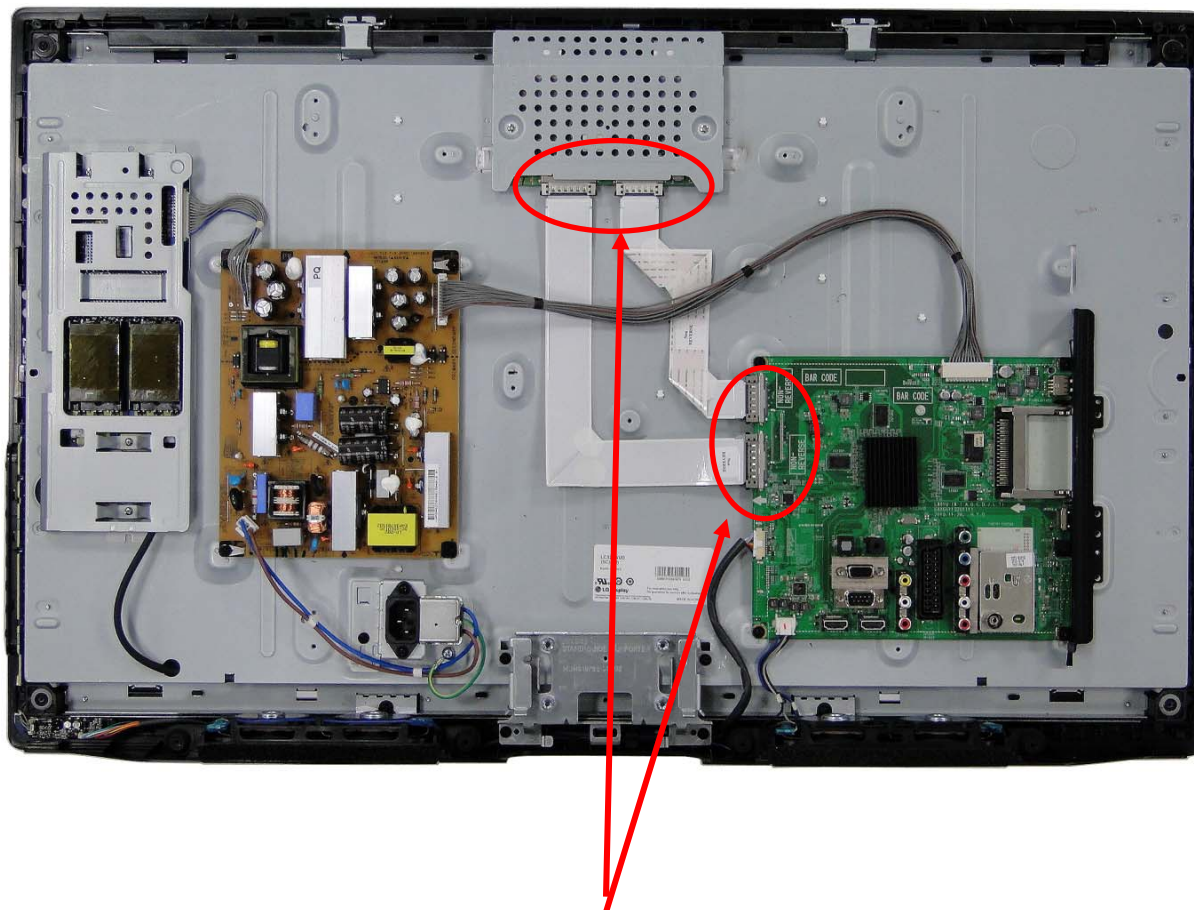

Check the contact condition of the Link Cable

Standard Repair Process Detail Technical Manual

LCD TV	Error symptom	A. Video error_Color error	Established date	2011. 2 .07	
	Content	Adjustment Test pattern - ADJ Key	Revised date		A12



You can view 6 types of patterns using the ADJ Key

Checking item : 1. Defective pixel 2. Residual image 3. MODULE error (ADD-BAR,SCAN BAR..)
4.Video error (Classification of MODULE or Main-B/D!)

Appendix : Exchange T-Con Board (1)



Solder defect, CNT Broken

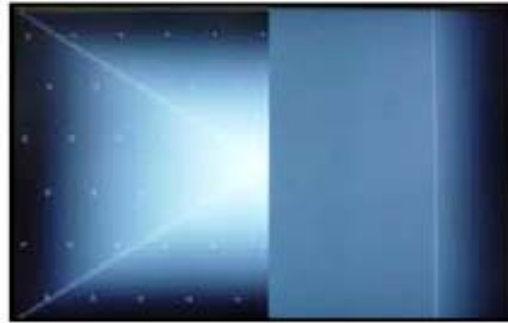

Solder defect, CNT Broken

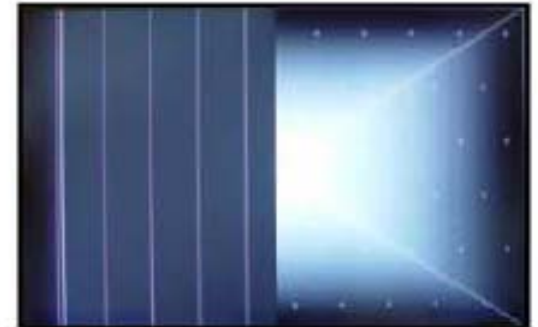

Solder defect, CNT Broken



Solder defect, CNT Broken

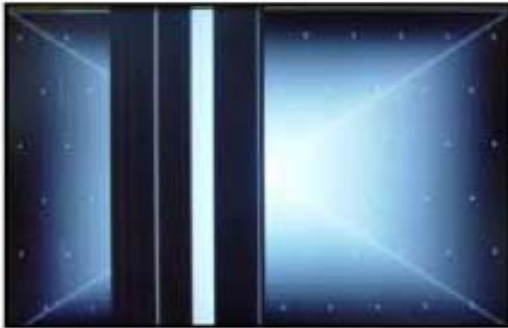

Solder defect, CNT Broken

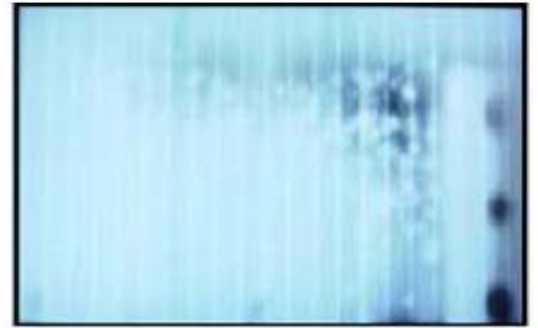

Abnormal Power Section

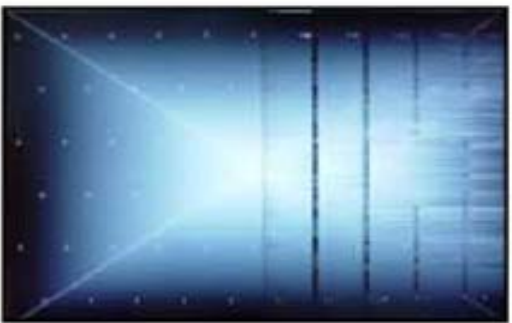

Solder defect, Short/Crack



Abnormal Power Section



Solder defect, Short/Crack

Appendix : Exchange T-Con Board (2)

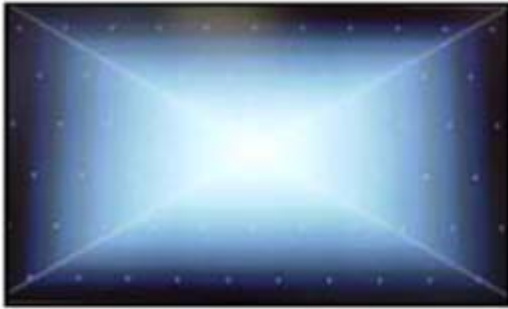

Abnormal Power Section



Abnormal Power Section



Solder defect, Short/Crack



Solder defect, Short/Crack



Fuse Open, Abnormal power section



Abnormal Display



GRADATION



Noise



GRADATION

Appendix : Exchange PSU(LED driver)



No Light



Dim Light



Dim Light

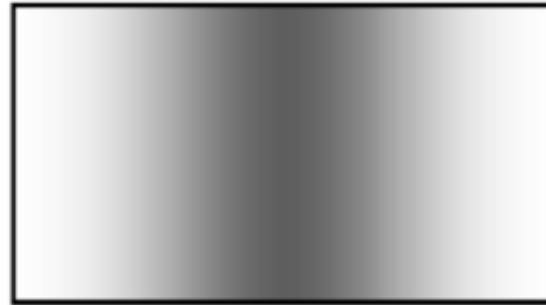

Dim Light



No picture/Sound Ok

Appendix : Exchange the Module (1)



Panel Mura, Light leakage



Panel Mura, Light leakage



Press damage

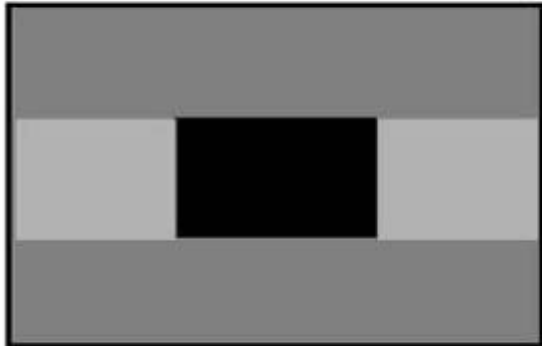

Crosstalk



Press damage



Crosstalk



Press damage

Un-repairable Cases

In this case please exchange the module.

Appendix : Exchange the Module (2)

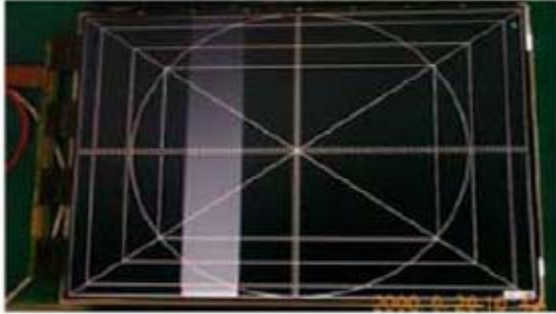

Vertical Block
Source TAB IC Defect



Vertical Line
Source TAB IC Defect



Vertical Block
Source TAB IC Defect



Horizontal Block
Gate TAB IC Defect



Horizontal Block
Gate TAB IC Defect

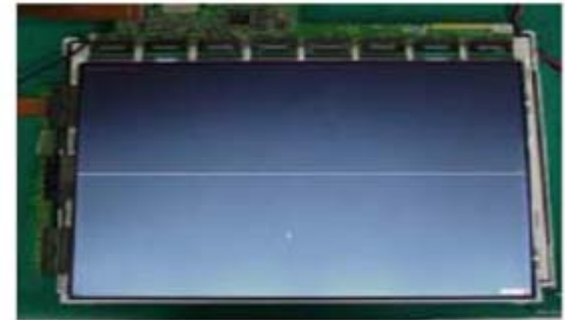

Horizontal line
Gate TAB IC Defect



Horizontal Block
Gate TAB IC Defect

Un-repairable Cases

In this case please exchange the module.

Standard Repair Process Detail Technical Manual

LCD TV	Error symptom	B. Power error _No power	Established date	2010. 2 .19	
	Content	Check front display LED	Revised date		A17

• Image shown may differ from your TV.

Only 32/37/42LK45**, 32/42LK55**, 32LV25**, 32/42LV34**, 32/37/40/42/47LV35**, 32/37/42/47LV45**, 32/37/42/47/55LV45**

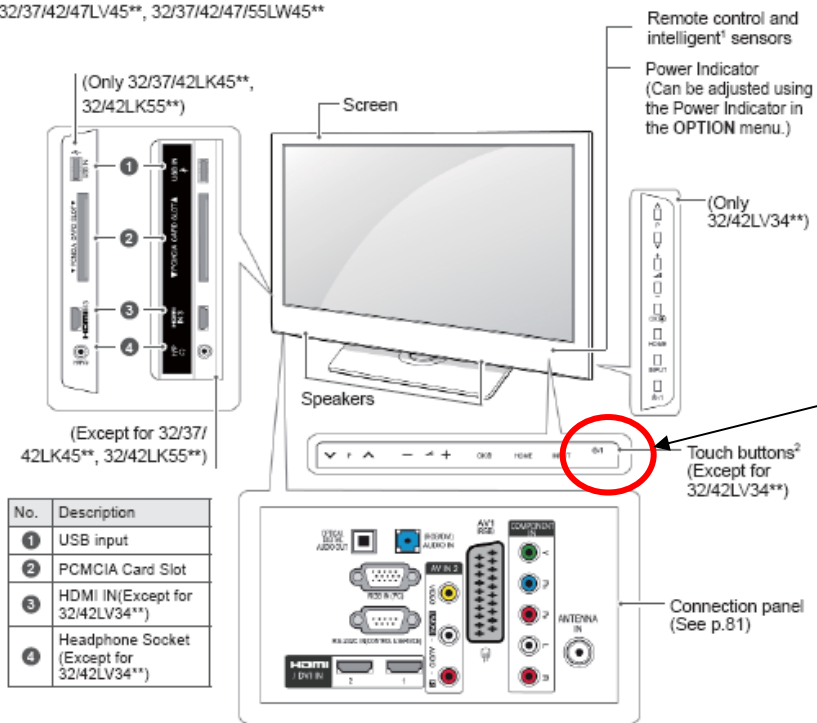

No.	Description
1	USB input
2	PCMCIA Card Slot
3	HDMI IN(Except for 32/42LV34**)
4	Headphone Socket (Except for 32/42LV34**)

Front LED control :
Menu → Option → Power Indicator
→ Standby light ON

ST-BY condition: Red
Power ON condition: white

Button	Description
↓ P ↑	Scrolls through the saved programmes
- ◀ +	Adjusts the volume level
OK	Selects the highlighted menu option or confirms an input
HOME	Accesses the main menus, or saves your input and exits the menus
INPUT	Changes the input source
⓪/I	Turns the power on or off

1 Intelligent sensor - Adjusts the image quality corresponding to the surrounding environment.

2 Touch Button - You can use the desired button function by touching.

Standard Repair Process Detail Technical Manual

LCD TV	Error symptom	B. Power error _No power	Established date	2011. 2 .07	
	Content	Check power input voltage and ST-BY 3.5V	Revised date		A18

For '11 models, there is no voltage out for st-by purpose.
When st-by, only 3.5V is normally on.

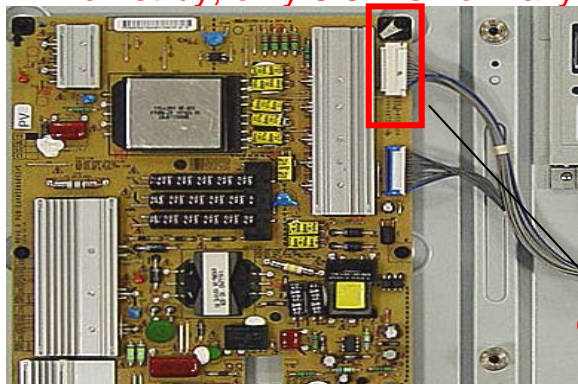

Edge LED PSU without LED Driver

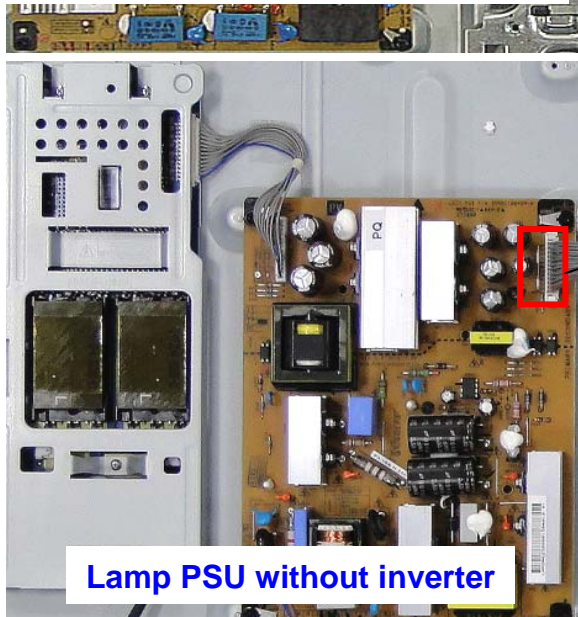

Lamp PSU without inverter

Check the 3.5V when st-by

24 Pin (Power Board ↔ Main Board) - 공통			
SMAW200-H24S (YEONHO)			
1	Power on	2	20V (24V)
3	20V (24V)	4	20V (24V)
5	GND	6	GND
7	GND	8	GND
9	3.5V	10	3.5V
11	3.5V	12	3.5V
13	GND	14	GND
15	GND	16	N.C
17	12V	18	Inverter On/off
19	12V	20	Lamp : A-Dim LED : N.C
21	12V	22	PWM Dim #1
23	N.C	24	Error-out

* Lamp SCANNING Model : PWM Dim #2

24 Pin (Power Board ↔ Main Board)			
FW20020-24SB (FOOSUNG)			
1	Power on	2	20V (24V)
3	20V (24V)	4	20V (24V)
5	GND	6	GND
7	GND	8	GND
9	3.5V	10	3.5V
11	3.5V	12	3.5V
13	GND	14	GND
15	GND	16	GND
17	12V	18	Inverter On/off
19	12V	20	Lamp : A-Dim
21	12V	22	PWM Dim #1
23	N.C	24	Error-out

Standard Repair Process Detail Technical Manual

LCD TV	Error symptom	B. Power error _No power	Established date	2011. 2 .07	
	Content	Checking method when power is ON	Revised date		A19

Check "power on" pin is high

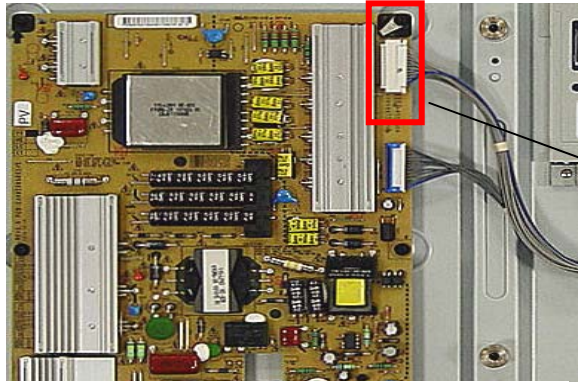

Edge LED PSU without LED Driver

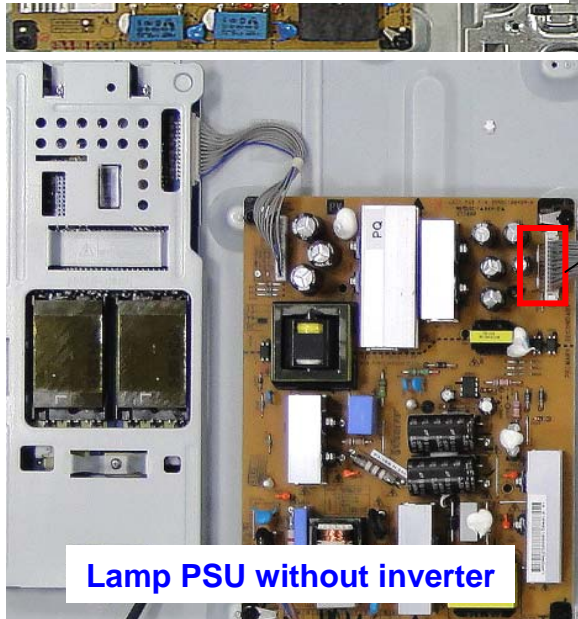

Lamp PSU without inverter

24 Pin (Power Board ↔ Main Board) - 공통			
SMAW200-H24S (YEONHO)			
1	Power on	2	20V (24V)
3	20V (24V)	4	20V (24V)
5	GND	6	GND
7	GND	8	GND
9	3.5V	10	3.5V
11	3.5V	12	3.5V
13	GND	14	GND
15	GND	16	N.C
17	12V	18	Inverter On/off
19	12V	20	Lamp : A-Dim LED : N.C
21	12V	22	PWM Dim #1
23	N.C	24	Error-out

• Lamp SCANNING Model : PWM Dim #2

24 Pin (Power Board ↔ Main Board)			
FW20020-24SB (FOOSUNG)			
1	Power on	2	20V (24V)
3	20V (24V)	4	20V (24V)
5	GND	6	GND
7	GND	8	GND
9	3.5V	10	3.5V
11	3.5V	12	3.5V
13	GND	14	GND
15	GND	16	GND
17	12V	18	Inverter On/off
19	12V	20	Lamp : A-Dim
21	12V	22	PWM Dim #1
23	N.C	24	Error-out

Standard Repair Process Detail Technical Manual

LCD TV	Error symptom	B. Power error _Off when on, off whiling viewing	Established date	2011. 2 .07	
	Content	POWER OFF MODE checking method	Revised date		A22

<ALL MODELS>

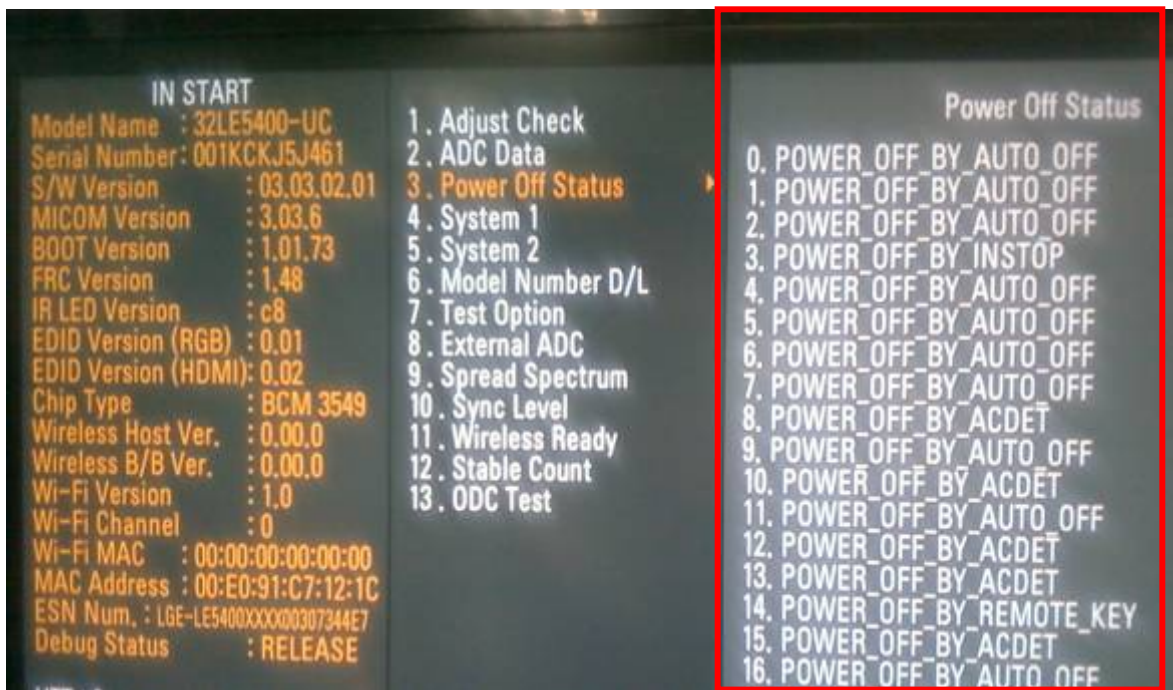

Entry method

1. Press the IN-START button of the remote controller for adjustment
2. Check the entry into adjustment item 3

Standard Repair Process Detail Technical Manual

LCD TV	Error symptom	C. Audio error_No audio/Normal video	Established date	2011. 2 .07	
	Content	Checking method in menu when there is no audio	Revised date		A24

<ALL MODELS>



Checking method

1. Press the MENU button on the remote controller
2. Select the AUDIO function of the Menu
3. Select TV Speaker from Off to On

Standard Repair Process Detail Technical Manual

LCD TV	Error symptom	C. Audio error_No audio/Normal video	Established date	2011. 2 .07	
	Content	Voltage and speaker checking method when there is no audio	Revised date		A25

<ALL MODELS>

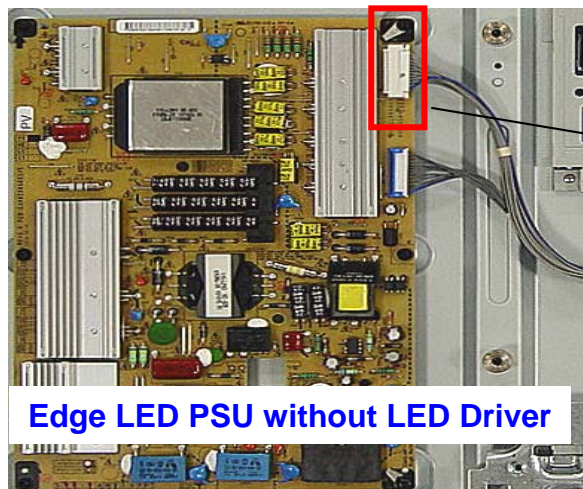

Edge LED PSU without LED Driver

②

24 Pin (Power Board ↔ Main Board) - 공통			
SMAW200-H24S (YEONHO)			
1	Power on	2	20V (24V)
3	20V (24V)	4	20V (24V)
5	GND	6	GND
7	GND	8	GND
9	3.5V	10	3.5V
11	3.5V	12	3.5V
13	GND	14	GND
15	GND	16	N.C
17	12V	18	Inverter On/off
19	12V	20	Lamp : A-Dim LED : N.C
21	12V	22	PWM Dim #1
23	N.C	24	Error-out

• Lamp SCANNING Model
: PWM Dim #2

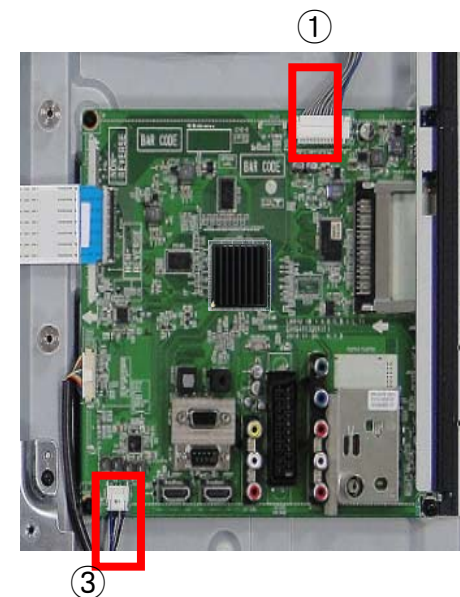

Checking order when there is no audio

- ① Check the contact condition of 20V or 24V connector of Main Board
- ② Measure the 24V input voltage supplied from Power Board
(If there is no input voltage, remove and check the connector)
- ③ Connect the tester RX1 to the speaker terminal and if you hear the Chik Chik sound when you touch the GND and output terminal, the speaker is normal.

Standard Repair Process Detail Technical Manual

LCD TV	Error symptom	D. Function error_ No response in remote controller, key error	Established date	2011. 2 .07	
	Content	Remote controller operation checking method	Revised date		A27

<ALL MODELS>

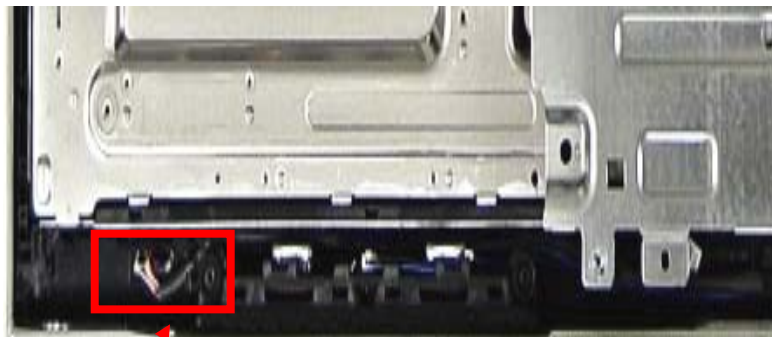

1

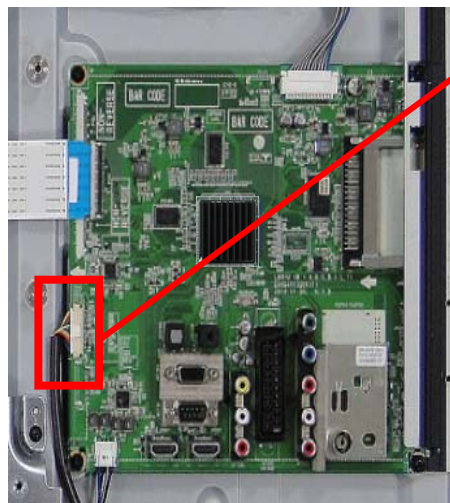

2

P2401, P2402	
1	EYEQ_SCL
2	EYEQ_SDA
3	GND
4	KEY1
5	KEY2
6	St 3.3V
7	GND
8	LED_R
9	IR
10	GND
11	Normal 3.3V
12	LED_R
13	GND
14	Soft Touch_SCL
15	Soft Touch_SDA

3

4

Checking order

- 1, 2. Check IR cable condition between IR & Main board.
3. Check the st-by 3.3V on the terminal 6.
4. When checking the Pre-Amp when the power is in ON condition, it is normal when the Analog Tester needle moves slowly, and defective when it does not move at all.