

Service Manual

Telephone Equipment

Caller ID Compatible

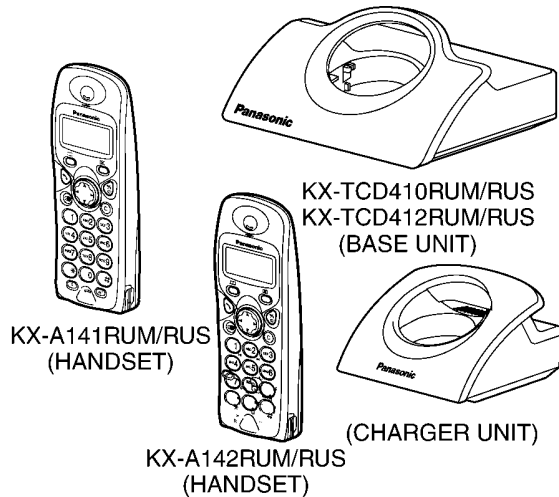

Configuration for each model

Model No	Base Unit	Handset	Charger
KX-TCD410	1	1	
KX-TCD412	1	2	1
KX-A142		1	1

KX-A142 is optional accessory.

KX-TCD410RUM
KX-TCD410RUS
KX-TCD412RUM
KX-TCD412RUS
KX-A141RUM
KX-A141RUS
KX-A142RUM
KX-A142RUS

Digital Cordless Phone

Metalic Gray Version

Silver Version

(for Russia)

SPECIFICATION

Standard:	DECT= (Digital Enhanced Cordless Telecommunications)
Number of channels:	120 Duplex Channels
Frequency range:	1.88 GHz to 1.9 GHz
Duplex procedure:	TDMA (Time Division Multiple Access)
Channel spacing:	1728 kHz
Bit rate spacing:	1152 kbit/s
Modulation:	GFSK= (Gaussian Frequency Shift Keying)
RF Transmission Power:	approx. 250 mW
Voice coding:	ADPCM 32 kbit/s
Operation range:	Up to 300 m outdoors, Up to 50 m indoors
Analog telephone connection:	Telephone Line
Power source:	AC Adaptor (220 V - 240 V AC, 50 Hz)

Power consumption, Base Unit:	Standby: 3.5 W / Maximum: 9.2 W
Charger Unit:	Standby: 2.3 W / Maximum: 6.8 W

Battery life, Handset (if batteries are fully charged):	Stand-by: Up to 120 hours (Ni-MH) Talk: Up to 10 hours (Ni-MH)
Operating conditions:	5 - 40 °C, 20 - 80 % relative air humidity (dry)

Dimensions, Base Unit (D x W x L):	58 mm x 128 mm x 105 mm
Dimensions, Handset (D x W x L):	143 mm x 48 mm x 32 mm
Dimensions, Charger Unit (D x W x L):	84 mm x 86 mm x 60 mm

Weight, Base Unit:	about 170 g
Weight, Handset:	about 120 g
Weight, Charger Unit:	about 113 g
Connection jack:	RJ11 to RJ11 Plug

Specifications are subject to change.

The illustrations used in this manual may differ slightly from the original device.

IMPORTANT INFORMATION ABOUT LEAD FREE, (PbF), SOLDERING

If lead free solder was used in the manufacture of this product the printed circuit boards will be marked PbF. Standard leaded, (Pb), solder can be used as usual on boards without the PbF mark.

When this mark does appear please read and follow the special instructions described in this manual on the use of PbF and how it might be permissible to use Pb solder during service and repair work.

Panasonic

© 2003 Panasonic Communications Co., Ltd. All rights reserved. Unauthorized copying and distribution is a violation of law.

⚠ WARNING

This service information is designed for experienced repair technicians only and is not designed for use by the general public. It does not contain warnings or cautions to advise non-technical individuals of potential dangers in attempting to service a product. Products powered by electricity should be serviced or repaired only by experienced professional technicians. Any attempt to service or repair the product or products dealt with in this service information by anyone else could result in serious injury or death.

When you note the serial number, write down all 11 digits. The serial number may be found on the bottom of the unit.

CONTENTS

	Page		Page
1 ABOUT LEAD FREE SOLDER (PbF: Pb free)	4	9.2. Handset	27
1.1. Suggested PbF Solder	4	9.3. Charger Unit	28
1.2. How to recognize that Pb Free solder is used	5	10 ASSEMBLY INSTRUCTIONS	29
2 FOR SERVICE TECHNICIANS	7	10.1. Warning When Constructing the Base Unit	29
3 CAUTION	7	11 TROUBLESHOOTING GUIDE	30
4 BATTERY	8	11.1. Check Power	31
4.1. Battery Installation	8	11.2. Check Battery Charge	32
4.2. Battery Charge	8	11.3. Check Link	33
4.3. Battery Life	9	11.4. Check Handset Transmission	35
4.4. Replacing the Batteries	9	11.5. Check Handset Reception	35
5 LOCATION OF CONTROLS	10	11.6. Check Caller ID	35
5.1. Base Unit	10	11.7. Bell Reception	36
5.2. Handset	10	12 CHECK PROCEDURE (BASE UNIT)	37
6 SETTINGS	11	12.1. Preparation	37
6.1. Connection	11	12.2. PC Setting	37
6.2. Symbols Used in This Service Manual	11	13 CHECK PROCEDURE (HANDSET)	38
6.3. PIN Code	12	13.1. Preparation	38
6.4. Reset	14	13.2. PC Setting	38
6.5. Key Lock	15	14 ADJUSTMENTS (BASE UNIT AND CHARGER UNIT)	39
6.6. Recall Feature	15	14.1. Adjustment (Base Unit)	39
6.7. Dialling Pause for PBX line/long distance service users	15	14.2. Adjustment Standard (Base Unit)	43
6.8. Call Restriction	16	14.3. Adjustment (Charger Unit)	45
6.9. Cancelling Call Restricted Handset(s)	16	14.4. Adjustment Standard (Charger Unit)	45
6.10. Call BAR On/Off (Call Prohibition On/Off)	16	15 ADJUSTMENTS (HANDSET)	46
6.11. Selecting the Display Language	17	15.1. Adjustment	46
6.12. Select Dialling Mode (Tone/Pulse)	17	15.2. Adjustment Standard (Handset)	49
6.13. Select Flash Timing	17	16 RF SPECIFICATION	50
6.14. Automatic Route Selection	18	16.1. Base Unit	50
6.15. Summary of Programmable Functions	20	16.2. Handset	50
7 DISPLAY	20	17 HOW TO CHECK THE HANDSET SPEAKER	50
7.1. Handset Display	20	18 FREQUENCY TABLE (MHz)	51
7.2. Before Requesting Help (Troubleshooting)	21	19 BLOCK DIAGRAM (BASE UNIT)	52
8 OPERATIONS	22	20 CIRCUIT OPERATION (BASE UNIT)	53
8.1. Power On/Off	22	20.1. Outline	53
8.2. Making a Call	22	20.2. Power Supply Circuit	54
8.3. Answering a Call	22	20.3. Telephone Line Interface	55
8.4. Setting the Clock/Date	22	20.4. Transmitter/Receiver	55
8.5. Phonebook	23	20.5. Pulse Dialing	55
9 DISASSEMBLY INSTRUCTIONS	26	20.6. FLASH PROM	55
9.1. Base Unit	26	21 BLOCK DIAGRAM (HANDSET)	56

22 CIRCUIT OPERATION (HANDSET)	57	33 ACCESSORIES AND PACKING MATERIALS	73
22.1. Outline	57	33.1. KX-TCD410RUM/RUS	73
22.2. Power Supply Circuit/Reset Circuit	57	33.2. KX-TCD412RUM/RUS	74
22.3. Charge Circuit	57	33.3. KX-A142RUM/RUS	75
22.4. Battery Low/Power Down Detector	57	34 TERMINAL GUIDE OF THE ICs, TRANSISTORS AND DIODES	
23 CIRCUIT OPERATION (CHARGER UNIT)	58	76
23.1. Power Supply Circuit	58	34.1. Base Unit	76
24 SIGNAL ROUTE	58	34.2. Handset	76
25 CPU DATA (BASE UNIT)	59	34.3. Charger Unit	76
25.1. IC2 (BBIC)	59	35 REPLACEMENT PARTS LIST	77
26 CPU DATA (HANDSET)	61	35.1. Base Unit	77
26.1. IC1 (BBIC)	61	35.2. Handset	78
27 EEPROM LAYOUT (BASE UNIT)	63	35.3. Charger Unit	79
27.1. Scope	63	35.4. Accessories and Packing Materials	79
27.2. Introduction	63	35.5. Fixtures and Tools	80
27.3. EEPROM Layout	63	36 SCHEMATIC DIAGRAM (BASE UNIT)	81
28 EEPROM LAYOUT (HANDSET)	66	37 SCHEMATIC DIAGRAM (HANDSET)	83
28.1. Scope	66	38 SCHEMATIC DIAGRAM (CHARGER UNIT)	85
28.2. Introduction	66	39 CIRCUIT BOARD (BASE UNIT)	86
28.3. EEPROM contents	66	39.1. Component View	86
29 HOW TO REPLACE FLAT PACKAGE IC	69	39.2. Flow Solder Side View	87
29.1. Preparation	69	40 CIRCUIT BOARD (HANDSET)	88
29.2. Procedure	69	40.1. Component View	88
29.3. Modification Procedure of Bridge	69	40.2. Flow Solder Side View	89
30 CABINET AND ELECTRICAL PARTS LOCATION (BASE UNIT)		41 CIRCUIT BOARD (CHARGER UNIT)	90
.....	70	41.1. Component View	90
31 CABINET AND ELECTRICAL PARTS LOCATION (HANDSET)	71	41.2. Flow Solder Side View	90
32 CABINET AND ELECTRICAL PARTS LOCATION (CHARGER UNIT)	72		

1 ABOUT LEAD FREE SOLDER (PbF: Pb free)

Note:

In the information below, Pb, the symbol for lead in the periodic table of elements, will refer to standard solder or solder that contains lead.

We will use PbF solder when discussing the lead free solder used in our manufacturing process which is made from Tin (Sn), Silver (Ag), and Copper (Cu).

This model, and others like it, manufactured using lead free solder will have PbF stamped on the PCB. For service and repair work we suggest using the same type of solder although, with some precautions, standard Pb solder can also be used.

Caution

- PbF solder has a melting point that is 50°F ~70°F (30°C ~ 40°C) higher than Pb solder. Please use a soldering iron with temperature control and adjust it to 700°F ± 20°F (370°C ± 10°C). In case of using high temperature soldering iron, please be careful not to heat too long.
- PbF solder will tend to splash if it is heated much higher than its melting point, approximately 1100°F (600°C).
- If you must use Pb solder on a PCB manufactured using PbF solder, remove as much of the original PbF solder as possible and be sure that any remaining is melted prior to applying the Pb solder.
- When applying PbF solder to double layered boards, please check the component side for excess which may flow onto the opposite side (See the figure below).

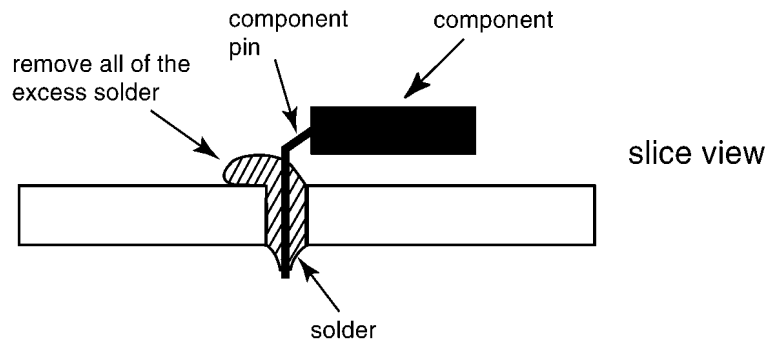

1.1. Suggested PbF Solder

There are several types of PbF solder available commercially. While this product is manufactured using Tin, Silver, and Copper (Sn+Ag+Cu), you can also use Tin and Copper (Sn+Cu) or Tin, Zinc, and Bismuth (Sn+Zn+Bi). Please check the manufacturer’s specific instructions for the melting points of their products and any precautions for using their product with other materials.

The following lead free (PbF) solder wire sizes are recommended for service of this product: 0.3mm, 0.6mm and 1.0mm.

0.3mm X 100g	0.6mm X 100g	1.0mm X 100g

1.2. How to recognize that Pb Free solder is used

1.2.1. Base Unit PCB

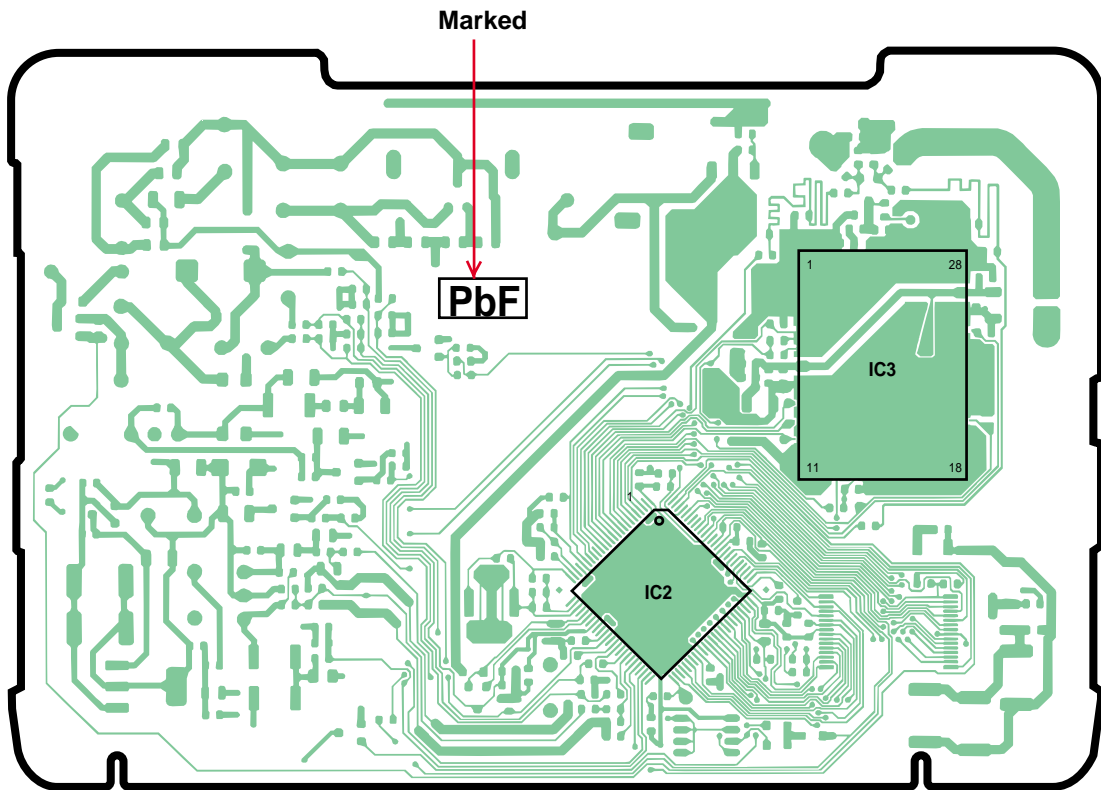

(Component View)

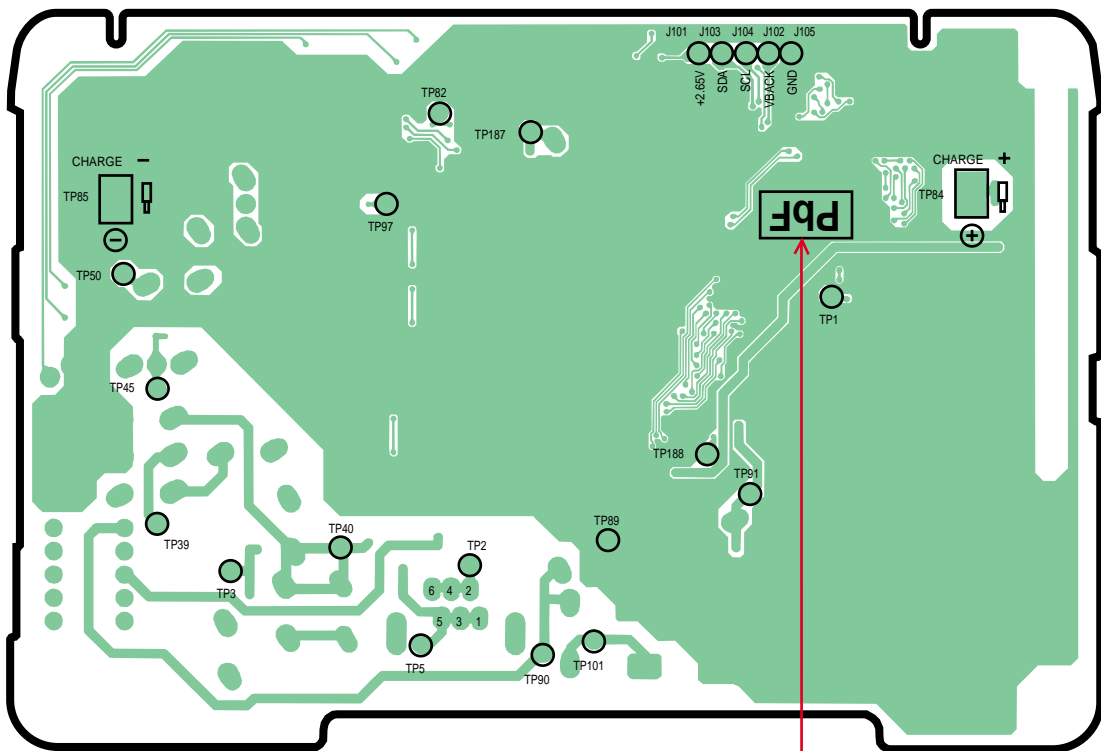

Marked

(Flow Solder Side View)

Note:

The location of the "PbF" mark is subject to change without notice.

1.2.2. Handset PCB

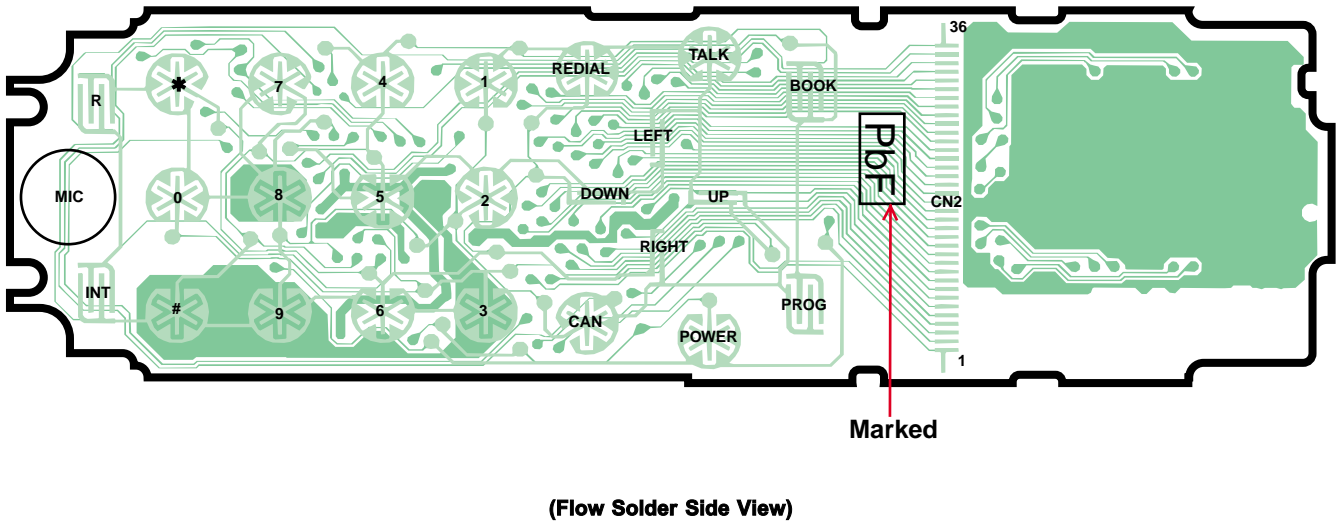
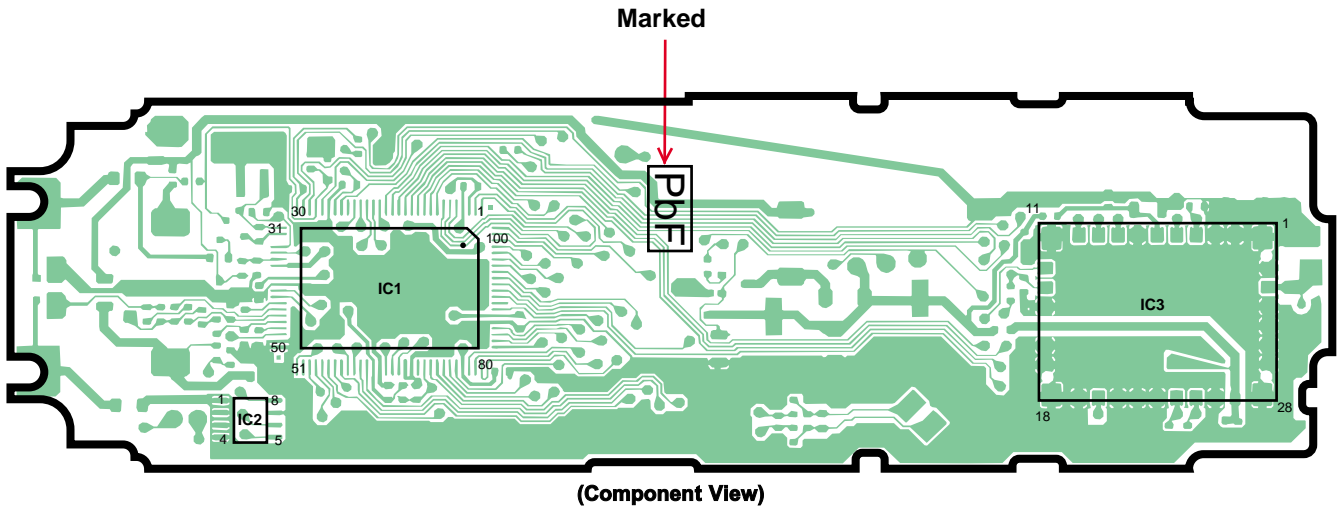

Note:
The location of the “PbF” mark is subject to change without notice.

1.2.3. Charger Unit PCB

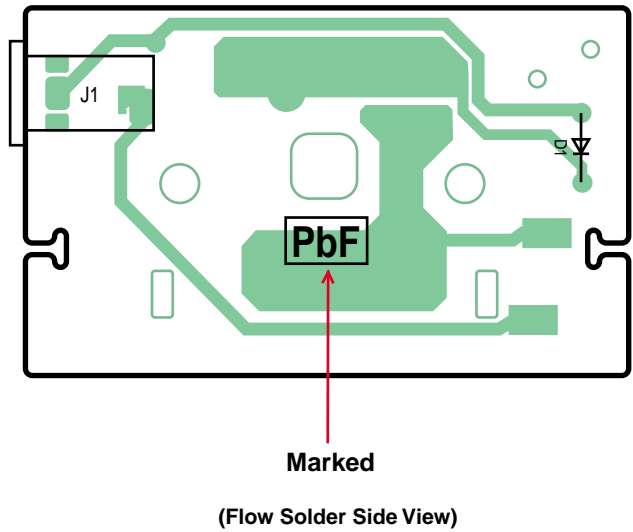
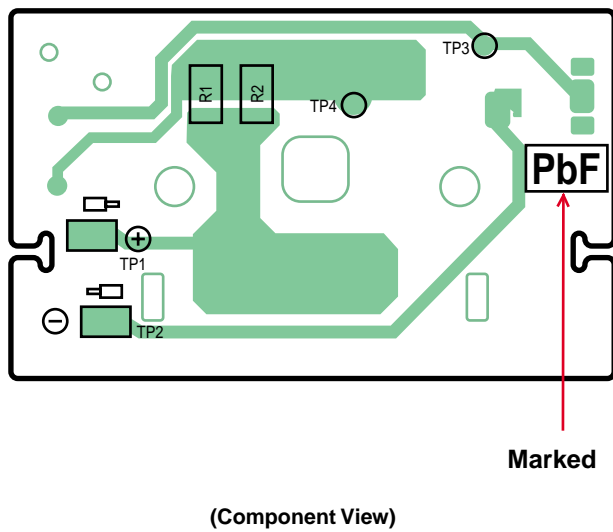

Note:
The location of the “PbF” mark is subject to change without notice.

2 FOR SERVICE TECHNICIANS

ICs and LSIs are vulnerable to static electricity.

When repairing, the following precautions will help prevent recurring malfunctions.

1. Cover the plastic parts boxes with aluminum foil.
2. Ground the soldering irons.
3. Use a conductive mat on the worktable.
4. Do not touch IC or LSI pins with bare fingers.

3 CAUTION

Danger of explosion if battery is incorrectly replaced. Replace only with the same or equivalent type recommended by the manufacturer.

Dispose of used batteries according to the manufacture's Instructions.

4 BATTERY

4.1. Battery Installation

Please ensure the batteries are inserted as shown. ⊖ part should be inserted first.

Close the cover as indicated by the arrow.

- When you replace the batteries, ⊕ part should be removed first.

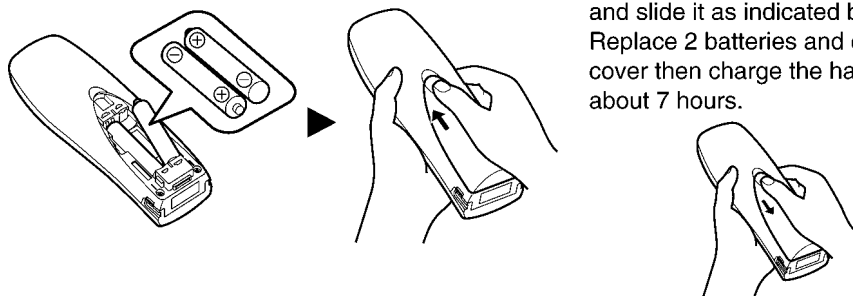

To replace the battery:
Press the notch on the cover firmly and slide it as indicated by the arrow.
Replace 2 batteries and close the cover then charge the handset for about 7 hours.

4.2. Battery Charge

At the time of shipment, the batteries are not charged. To charge, place the handset on the base unit.

Please charge the batteries for about 7 hours before initial use. During charging, the battery icon is as shown below.

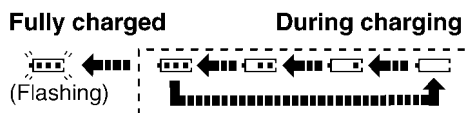
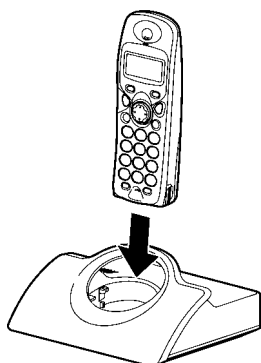

Display icon	Battery strength
	High
	Medium
	Low
	Needs to be charged

The handset which power is off will be turned on automatically when it is placed on the base unit.

In normal use, the handset and the base unit should be powered on at all times.

Note for Service:

The battery strength may not be indicated correctly if the battery is disconnected and connected again, even after it is fully charged.

In that case, by recharging the battery as mentioned above, you will get a correct indication of the battery strength.

4.3. Battery Life

- Battery life is dependent on use and conditions but in general when using fully charged Ni-MH batteries (700 mAh):
Talk time: 10hrs approx.
Standby time: 120hrs approx.
- When using Ni-Cd batteries (250 mAh):
Talk time: 4hrs approx.
Standby time: 40hrs approx.
(Times indicated are for peak performance)
- The batteries reach peak performance after several full charge/discharge cycles.
- The batteries cannot be overcharged unless they are repeatedly removed and replaced.
- If battery life is shortened then please check that battery and charge terminals are clean.
- For maximum battery life, it is recommended that the handset is not recharged until battery icon flashes .

4.4. Replacing the Batteries





If the  icon flashes after a few telephone calls even when the handset batteries have been fully charged, 2 batteries must be replaced.



Charge new batteries for approximately 7 hours before initial use.

(The telephone line cord must not be connected to the telephone socket at this time).

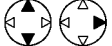
When replacing the batteries, ensure that the correct battery type is selected.

Selecting the Battery Type

1  Press MENU.	2  Search/Select "SETTING HS".	3  Search/Select "OTHER OPT".	4  Search/Select "BATTERY TYPE".
5  Search/Select "NI-CD" or "NI-MH".			

- To exit the operation, press  any time.
- When Ni-Cd batteries are fitted with the "BATTERY TYPE" setting in "NI-MH",  icon will disappear and stop charging even if the handset is on the cradle.
- Do not use non-rechargeable batteries. If non-rechargeable batteries are fitted and start charging, it may cause the leakage of the battery electrolyte.

Please use only Panasonic P03P(Ni-MH) or P03H(Ni-Cd) batteries.

5 LOCATION OF CONTROLS

5.1. Base Unit

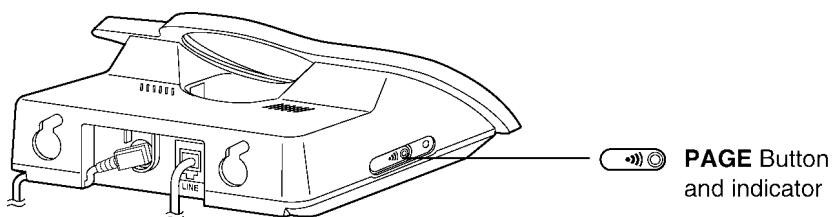

5.2. Handset

(For KX-A141RUM/RUS)

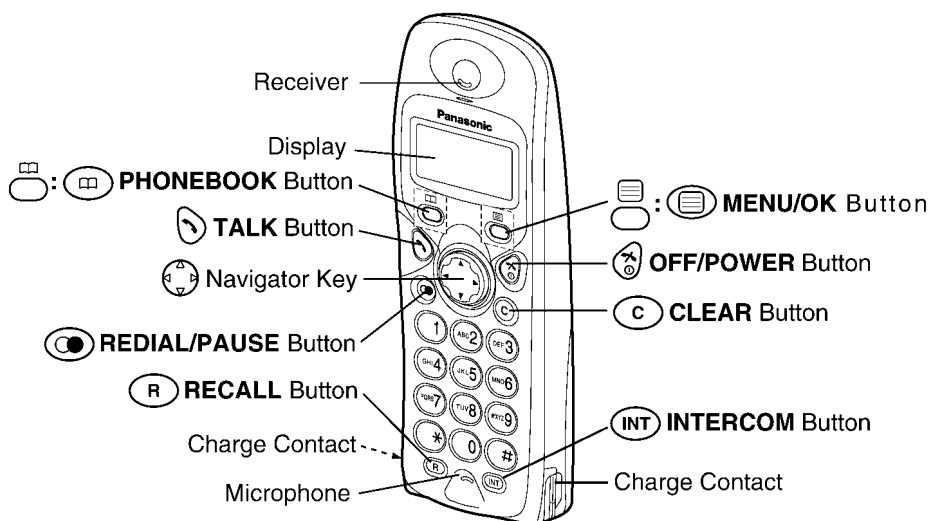

(For KX-A142RUM/RUS)

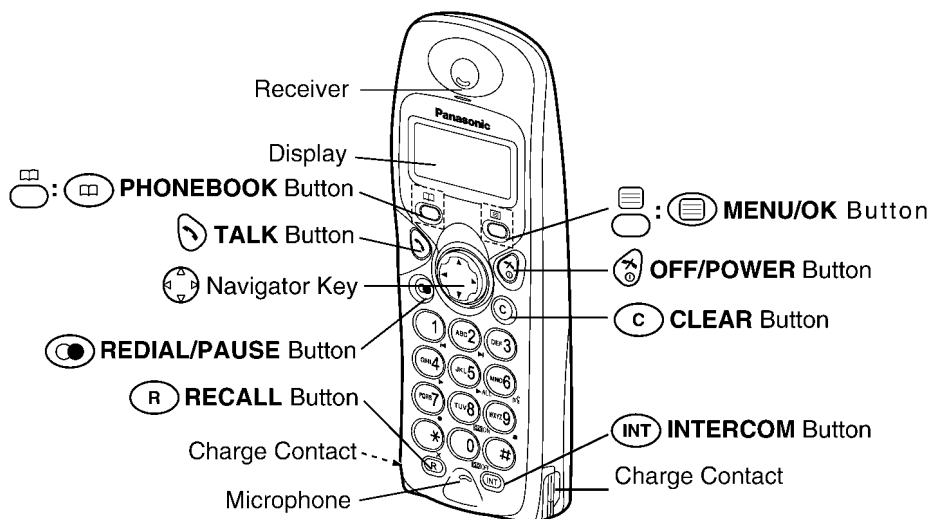

6 SETTINGS

6.1. Connection

6.1.1. Base Unit

Plug in the AC adaptor and the telephone line cord in order **1, 2, 3, 4.**

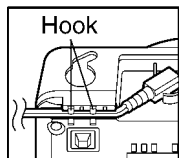

Fasten the AC adaptor cord to prevent it from being disconnected.

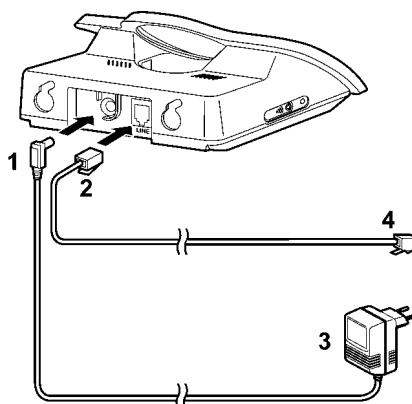

The AC adaptor must remain connected at all times (It is normal for the adaptor to feel warm during use).

- Never install telephone wiring during a lightning storm.

6.1.2. Charger Unit

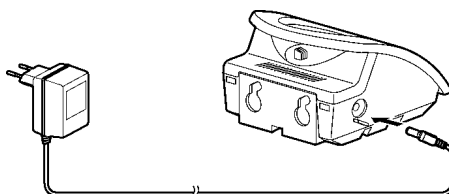



The AC adaptor must remain connected at all times (It is normal for the adaptor to feel warm during use).

6.2. Symbols Used in This Service Manual

Symbol	Meaning
	To search the desired item, press UP or DOWN .
	To select the desired item, press RIGHT .
	To search and then to select the desired item, press UP or DOWN then RIGHT .
	To move the cursor to the right or to the left, press RIGHT or LEFT .
	To go to the next step.
" "	The words in " " indicate the words in display.

6.3. PIN Code

6.3.1. Base Unit

1		2		➔ "INPUT CODE"
	Press MENU.		Search/Select "SETTING BS".	
3		4*	Current 4-digit Base Unit PIN	
5	New 4-digit Base Unit PIN		6 New 4-digit Base Unit PIN again to verify	

Changing Base Unit PIN





The factory preset is 0000. **Once you have programmed the base unit PIN, you cannot confirm it. We recommend you write down the base unit PIN. If you forget it, please consult your Panasonic Service Centre.**

- To exit the operation, press  any time.

For Service Hint:

* : If the current 4-digit PIN is forgotten, press  **7000** and you will be able to enter new PIN.

6.3.2. Handset

1		2		3	
	Press MENU.		Search/Select "SETTING HS".		Search/Select "OTHER OPT".
4		5* Current 4-digit Handset PIN			
	Search/Select "HSPIN CHANGE".				
6	New 4-digit Handset PIN		7 New 4-digit Handset PIN again to verify		

Changing Handset PIN

The factory preset is 0000. **Once you have programmed the handset PIN, you cannot confirm it. We recommend you write down the handset PIN. If you forget it, please consult your Panasonic Service Centre.**

- To exit the operation, press  any time.

For Service Hint:

* : If the current 4-digit PIN is forgotten, press  **7000** and you will be able to enter new PIN.

6.3.3. Reset Base Unit PIN to Default (0000) -When There is NO Handset Registered-

6.3.3.1. Symptom

There is no way to reset base PIN when there is no handset registered to the base.

6.3.3.2. Thinkable Situation

- Customer may ask to reset base PIN because they forget it.
- Customer may bring only a base unit for repair and there is no handset registered to the base (Need to register another handset to the base to confirm if the unit works properly after repair).
- When original handset has broken and customer purchased a new one, if customer forget base PIN, customer cannot register the new handset and may ask to reset the PIN.

6.3.3.3. Remedy

<Preparation>

Refer to **JIGs and PC** (P.37).

<Connection>

1. Solder a pin or lead wire to GND, SDA, and SCLK on base PCB.
2. Plug in AC adaptor to the base.
3. Turn on the power to the JIG (9V).
4. Then connect the cable to each pins using **clip**.

As for the connection between JIG and PCB, see below photos.

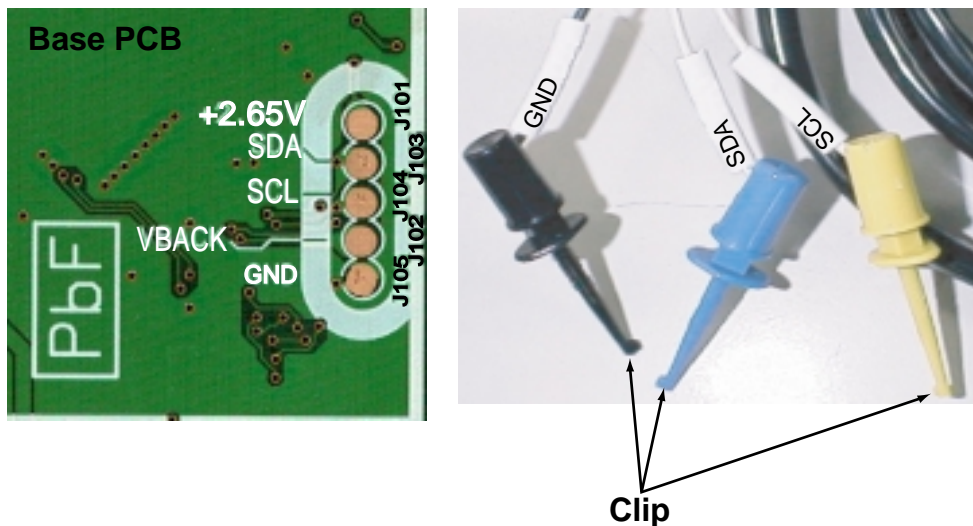

<PC setting and how to reset base PIN to default (0000)>

1. Refer to **PC Setting** (P.37).
2. Next, execute <initbspin.bat> by typing "initbspin". The PC display will be shown as below.

```

コマンドプロンプト
Microsoft Windows 2000 [Version 5.00.2195]
(C) Copyright 1985-2000 Microsoft Corp.
C:\>cd dect
C:\DECT>SET RTX_COM=1
C:\DECT>DOSKEY
C:\DECT>initbspin
C:\DECT>call wreeprom.bat 00 25 00
C:\DECT>call wreeprom.bat 00 26 00
C:\DECT>_

```





3. After that, turn off DC power supply (9V) to the jig, unplug AC adaptor, and remove pins on PCB.

Then close the cabinet. The base pin returns to the default (0000) and you can register a handset to the base using the base PIN (0000).

6.4. Reset

6.4.1. Base Unit

If the base unit is reset, the Caller ID list will clear.

1		2		→ "INPUT CODE"	3	
	Press MENU .		Search/Select			
			"SETTING BS".			
4	4-digit Base Unit PIN*1		5		Press OK .	





- To exit the operation, press  any time.
- *1: The factory preset is 0000.

Base Unit Initial Settings

Function	Initial Setting	Remarks (selectable options)
Ringer Mode	All Handsets	All Handsets/Specific Handset No.
Number of Rings	3	Up to 6 rings
Dialling Mode	Tone	Tone/Pulse
Pause Timing	3 seconds	3 seconds/5 seconds
Call Restricted Handsets	All Clear	Each Handset can be set individually.
Call Restriction Numbers	All Clear	Up to 10 numbers (up to 8 digits)
4-Digit Base Unit PIN	0000	-
Flash Timing	700 msec	100/700/200 msec
ARS Setting	OFF	ON/OFF
Carrier Code	All Clear	-
Area Code	All Clear	-
Relation of Area Code	All Area Code to Carrier Code 1	1 to 5

6.4.2. Handset

You can reset all of the handset settings to their initial settings.

1		2		3		4	4-digit Handset PIN*1	
	Press MENU .		Search/Select		Search/Select			
			"SETTING HS".		"RESET HS".			
5		Search/Select						
		"YES" or "NO".						

- To exit the operation, press  any time.
- *1: The factory preset is 0000.

Handset Initial Settings

Function	Initial Setting	Remarks (selectable options)
Time Alarm Mode	OFF	OFF/ON
Alarm Time	Clear	OFF/Once/Daily
Handset Ringer Volume	6	-
Handset External Ringer Pattern	1	20 patterns
Handset Internal Ringer Pattern	1	20 patterns
Handset Paging Tone Pattern	1	20 patterns
Handset Alarm Tone Pattern	1	20 patterns
Key Tone	ON	ON/OFF
Call Waiting Tone	ON	ON/OFF
Range Warning Alarm	OFF	OFF/ON
Battery Low Alarm	ON	ON/OFF
Standby Mode Display	Clock	Clock/OFF/Base No./Handset No.
Talk Mode Display	Length of the Call	Talk Time/Phone No.
Display Language	English	10 languages
Call BAR	OFF	OFF/ON
Direct Call Mode	OFF	OFF/ON
Direct Call Number	Clear	Up to 24 digits
4-Digit Handset PIN	0000	-
Auto Talk	OFF	OFF/ON
Base Unit Access	Automatic Base Unit Access	Auto/Specific Base Unit No.
Redial Memory	All Clear	-
Handset Receiver Volume	Medium	Low/Medium/High

6.5. Key Lock

You can lock the handset dialling buttons. Only incoming calls are accepted while the key lock is on. The key lock is cancelled if the handset is turned off.

When the key lock is on, emergency calls cannot be made until key lock is cancelled.

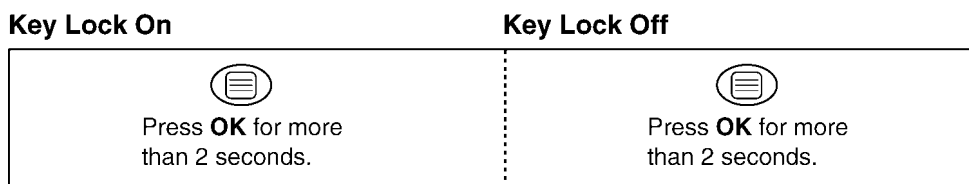

-  is displayed (Refer to **Handset Display** (P.20)) and all dialling buttons are locked.

6.6. Recall Feature

RECALL is used to access special telephone services. Contact your Network provider for details. If your unit is connected to a PBX, pressing **RECALL** allows you to access some features of your host PBX such as transferring an extension call.

6.7. Dialling Pause for PBX line/long distance service users

A dialling pause is used when a pause in the dialling of the phone number is necessary using a PBX or accessing a long distance service.

For example, when 9 (line access number) is dialled followed by a pause to access an outside line through a PBX:





- Entering a pause prevents misdialling when you redial or dial a stored number.
- Pressing **PAUSE** once creates one pause. To extend the pause requirement time, press **PAUSE** accordingly.

*1  is displayed (Refer to **Handset Display** (P.20)) on the LCD.

6.8. Call Restriction

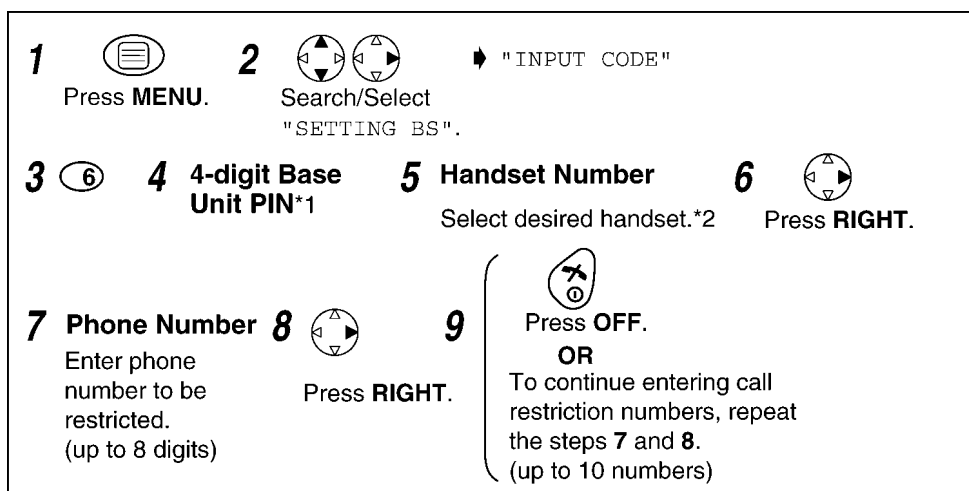
You can restrict selected handset(s) from dialling selected phone numbers. You can assign up to 10 call restriction numbers (up to 8 digits). If you dial a restricted number, the call does not connect and restricted number flashes.



- To exit the operation, press  any time.
- *1: The factory preset is 0000.
- *2: The selected handset number flashes.

6.9. Cancelling Call Restricted Handset(s)

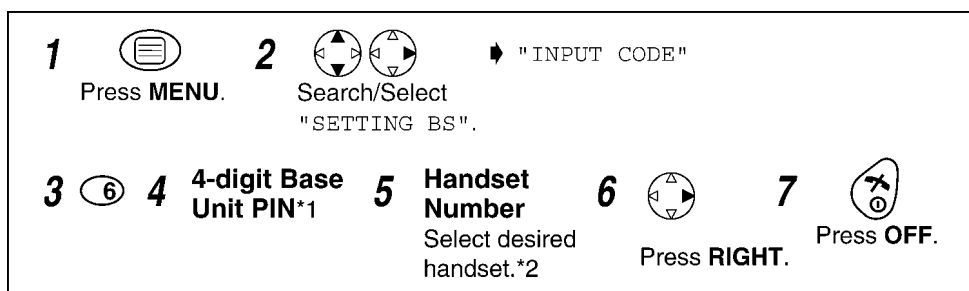



- To exit the operation, press  any time.
- *1: The factory preset is 0000.
- *2: The selected handset(s) will stop flashing.

6.10. Call BAR On/Off (Call Prohibition On/Off)

You cannot make any dialling if call BAR is on.



- To exit the operation, press  any time.
- *1: The factory preset is 0000.
- *2: If "ON" is selected,  is displayed (Refer to **Handset Display** (P.20)).

6.11. Selecting the Display Language

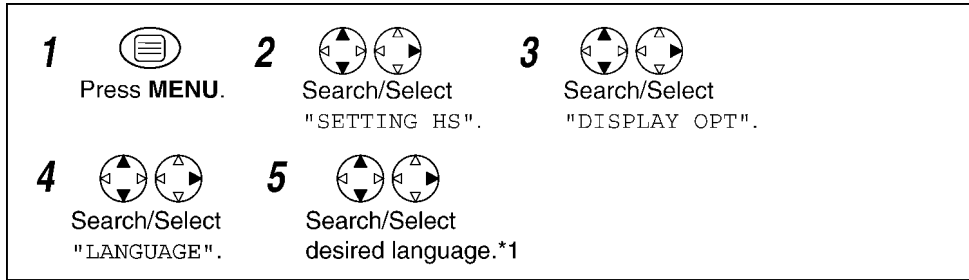

- To exit the operation, press any time.
- *1 You can select one of 10 languages. If you set a language you cannot read, reset the handset to its initial settings.
Press MENU → DOWN → RIGHT → UP → RIGHT → 4-digit Handset PIN → UP → OK
All handset setting will be reset to their initial settings, however, the Phonebook data will be saved.

6.12. Select Dialling Mode (Tone/Pulse)

You can change the dialling mode to tone or pulse depending upon your network service. If you have a touch tone service, select tone. If you have rotary or pulse service, select pulse.

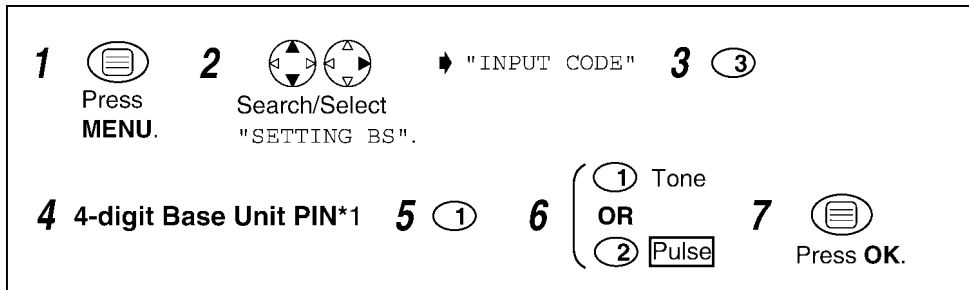

- To exit the operation, press any time.
- *1: The factory preset is 0000.

6.13. Select Flash Timing

You can change the duration of the flash timing depending on the requirements of your PBX requirements.

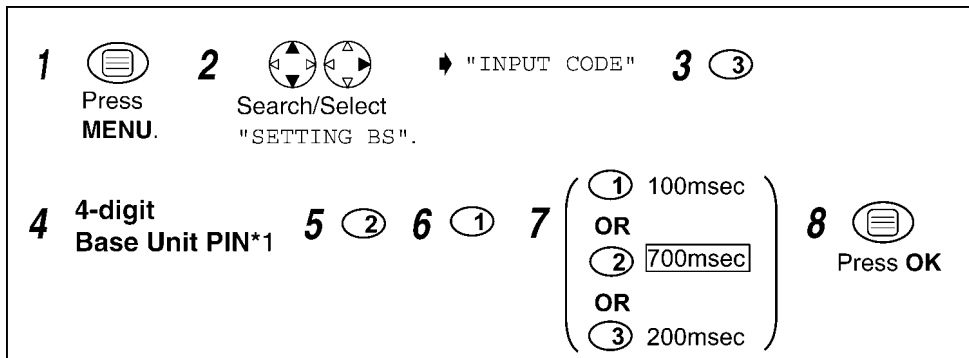

- To exit the operation, press any time.
- *1: The factory preset is 0000.

For Service Hint: Refer to **Select Flash Timing** (P.64)

6.14. Automatic Route Selection

Automatic Route Selection is a feature which selects the least expensive carrier (network) service available, when making long distance calls.

When area code(s) have been related to carrier codes, you will need only dial the area code, the lower costing carrier (network) will automatically be dialled.

Please contact your telephone company regarding the carrier telephone charges.

6.14.1. Storing the Carrier Code(s)

Firstly you must subscribe to a second carrier (network) service. You can subscribe to a limit of 5 carrier services. Then store the code as follows:

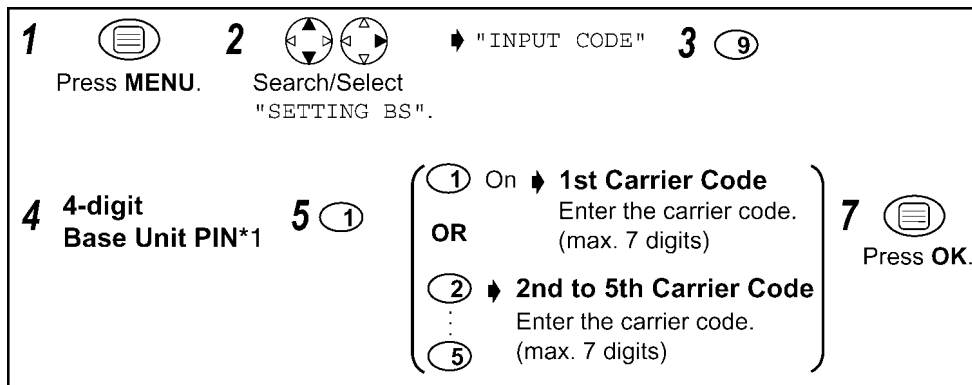

- To exit the operation, press any time.
- *1: The factory preset is 0000.

6.14.2. Storing the Area Code(s)

Store the area code(s) for which the chosen carrier (network) service charge rates are lower than the original carrier (network) service. Up to 25 area codes can be stored.

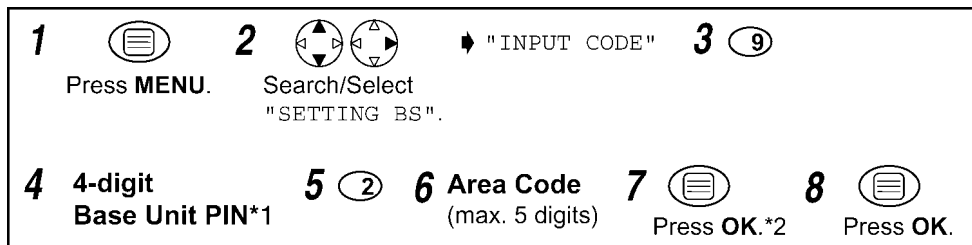

- To exit the operation, press any time.
- *1: The factory preset is 0000.
- *2 If you need more area code storing, repeat the steps from **6**.

6.14.3. Relate the Area Code(s) to the Carrier Code(s)

After storing carrier code(s) and area code(s), you must relate the stored area code(s) to your chosen lower costing carrier code. It is only necessary to relate area codes to carrier codes if more than one carrier code has been stored. If only one carrier code has been stored, any area codes you store (up to 25) will automatically be dialled with that carrier code.

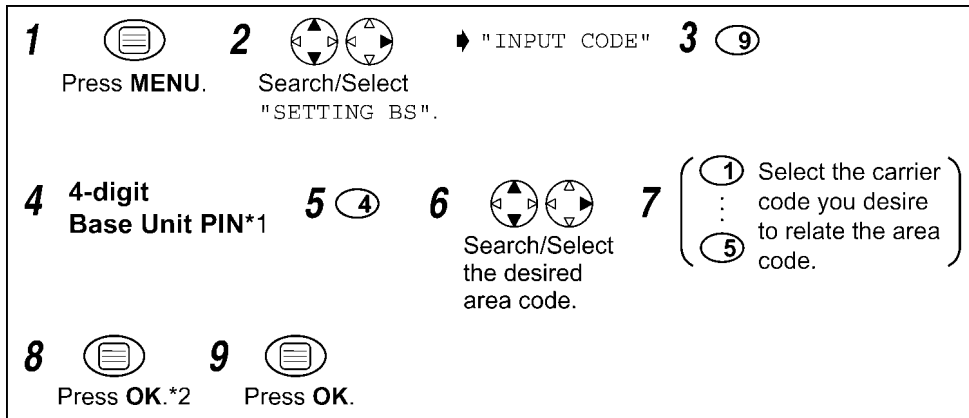

- To exit the operation, press any time.
- *1: The factory preset is 0000.
- *2 If you need more relating area codes to carrier codes, repeat the steps from 5.

6.14.4. Automatic Route Selection On/Off

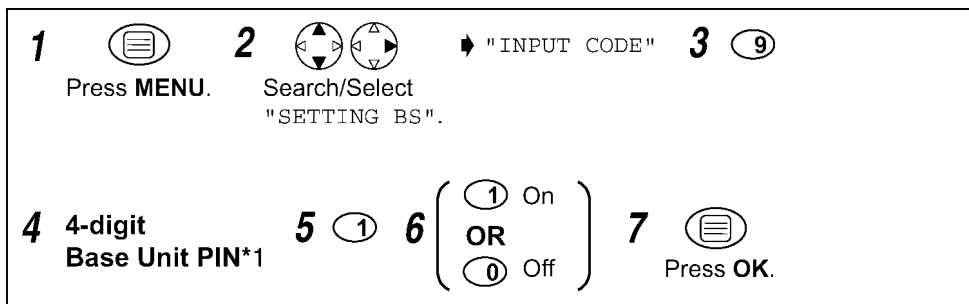

- To exit the operation, press any time.
- *1: The factory preset is 0000.

6.15. Summary of Programmable Functions

You can select and execute the following functions by pressing direct command as follows without programming.

These operations need to be done with the Handset near the base unit.

Press . Press or until the arrow points to "Setting Base" , then press .

"Input Command" is displayed.*1

<Direct command>

4-digit Base Unit PIN	Setting the All Handsets Mode
4-digit Base Unit PIN	Setting the Selected Handsets Mode
4-digit Base Unit PIN	Setting the Selected then All Handsets Mode
4-digit Base Unit PIN	Select Dialling Mode (Tone/Pulse)
4-digit Base Unit PIN	Select Flash Timing
4-digit Base Unit PIN	Pause Timing
	Changing Base Unit PIN
	Call Restriction
	Cancelling a Handset
4-digit Base Unit PIN	Automatic Route Selection
	Reset Base Unit Settings
	Setting the Clock
	Setting the Date

*1 If any key is not pressed over 60 seconds, the display will return to "Setting Base".

*2 Refer to **PIN Code** (P.12) for more details.

7 DISPLAY

7.1. Handset Display

Icon	Displays	Icon	Displays
	Within range of a base unit		Call Bar ON
	Out of range/No registration/ No power on base unit		Direct Call ON
	Paging or using the handset		Key Lock ON
	Making or answering calls		Ringer Volume OFF
	Phonebook Mode		Dialling Pause
	In Setting Mode		
	Battery strength is low		
	Battery strength is high		

7.2. Before Requesting Help (Troubleshooting)





If you experience any problems with the normal use of your apparatus, you should unplug it from the telephone outlet and connect a known working telephone in its place.

If the known working telephone still has problems, then please contact the customer service department of your Network provider.

If it operates correctly, then the problem is likely to be a fault in your apparatus.

In this case, contact your supplier for advice. Your Network provider may charge you if they attend a service call that is not due to apparatus supplied by them.

Turn the power OFF then ON (Handset) / Disconnect then connect the AC adaptor (Base Unit).

Problem	Possible cause	Solution
NO LCD display in handset.	<ul style="list-style-type: none"> Handset not turned on. 	<ul style="list-style-type: none"> Turn on power. →(Refer to Power On/Off.)
Handset will not turn on.	<ul style="list-style-type: none"> Batteries not inserted. Batteries not charged. 	<ul style="list-style-type: none"> Insert the 2 rechargeable batteries supplied . Place handset in base and connect AC adaptor to base and AC outlet (full charge period 7 hrs).
Batteries charge icon not counting up.	<ul style="list-style-type: none"> Dirty charge contact. Base not powered up. 	<ul style="list-style-type: none"> Clean charge / battery contact and retry charge. Connect AC adaptor to base unit and AC outlet.
 icon flashes.	<ul style="list-style-type: none"> Handset not registered to base. Handset out of range of base. No power into base unit. 	<ul style="list-style-type: none"> Register handset to base. Move handset closer to base. Connect AC adaptor to base unit and AC outlet.
Handset busy tone heard when  is pressed.	<ul style="list-style-type: none"> Handset out of range of base. Another handset in use. 	<ul style="list-style-type: none"> Move handset closer to base. Wait for the other user to complete call.
No dial tone.	<ul style="list-style-type: none"> Telephone line not connected. 	<ul style="list-style-type: none"> Insert telephone cord to network. Turn power OFF then ON.
Cannot dial out.	<ul style="list-style-type: none"> Call BAR set. Particular dialled number is restricted. Key lock mode ON. 	<ul style="list-style-type: none"> Turn feature off. →(Refer to Call BAR On/Off.) Remove number from call restricted list. Turn key lock OFF. →(Refer to Key Lock.)
Handset will not ring.	<ul style="list-style-type: none"> Ringer switched off. 	<ul style="list-style-type: none"> Set ringer to one of 6 volume levels.
Last number redial does not work.	<ul style="list-style-type: none"> Number exceeded 24 digits. 	<ul style="list-style-type: none"> Redial manually.
No Caller ID number displayed.	<ul style="list-style-type: none"> Service not supplied. Caller has withheld info. 	<ul style="list-style-type: none"> Caller ID service must be arranged with Network provider.
 icon flashes.	<ul style="list-style-type: none"> Battery low. 	<ul style="list-style-type: none"> Recharge batteries.
 icon is disappeared.	<ul style="list-style-type: none"> Wrong battery type selected. 	<ul style="list-style-type: none"> Set the correct battery type.
Cannot register handset to base.	<ul style="list-style-type: none"> Max. number of bases already registered to handset. Max. number of handsets already registered to base unit. Wrong PIN number entered (Default 0000). Electrical noise in local area. 	<ul style="list-style-type: none"> Delete unused base registrations from handset. Delete unused handset registrations from base. If PIN number is lost, contact the Panasonic Service Centre. →(Refer to Call Restriction.) Move base/handset away from sources of electrical noise (e.g TV, radio).

Cross Reference:

Power On/Off (P.22)

Call BAR On/Off (Call Prohibition On/Off) (P.16)

Key Lock (P.15)

Call Restriction (P.16)

8 OPERATIONS

8.1. Power On/Off

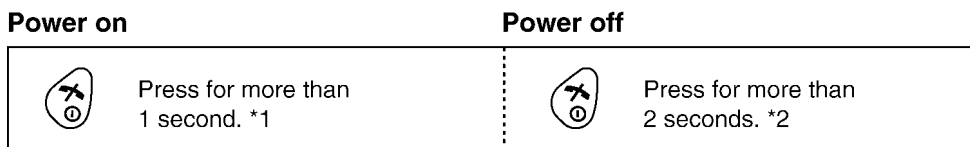

*1 When  button is released, the display changes to the standby mode.

*2 The display goes blank.

8.2. Making a Call

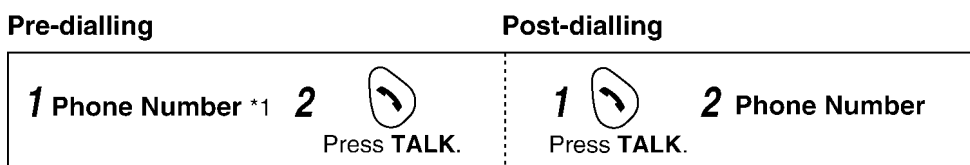

*1 If you need correction, press **CLEAR**. Digit is cleared to the left, then enter numbers.

8.3. Answering a Call

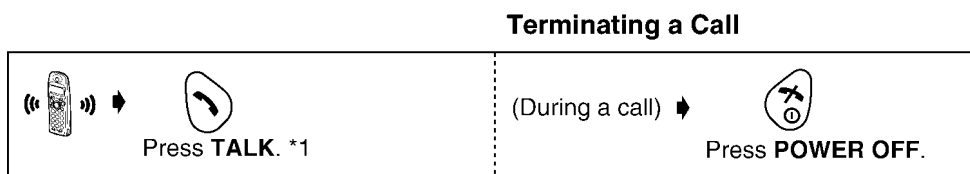



• Each ringer will start ringing with lower volume then gradually increase the volume when receiving a call.

*1 You can also answer a call by pressing any dialling button, **INTERCOM**, # , or ✕ .

8.4. Setting the Clock/Date

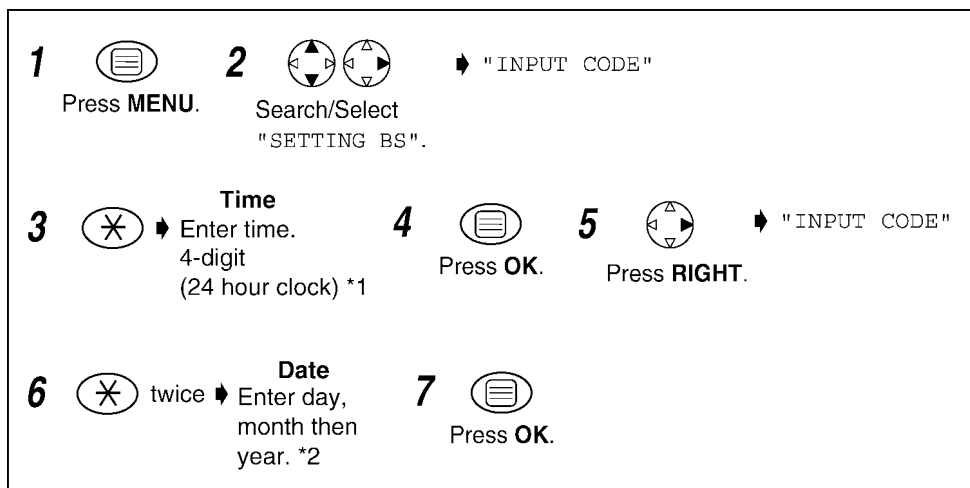
After a mains power failure the clock needs to be reset. Ensure that  icon is not flashing.



• To exit the operation, press  any time.





*1 For example, to set 7:15, enter 0715.

*2 For example, to set the 16th of February, 2003, enter 160203.

8.5. Phonebook

You can store up to 20 caller information in the phonebook. If you received a call from the same phone number you stored with a name in the phonebook, the display will show the caller's name.

8.5.1. Storing a Caller Information











1  Press MENU .	2  Select "NEW PHONE".	3 Phone Number Enter phone number. (max. 24 characters) *1	4  Press OK .
5 Name Enter name. (max. 9 characters)*1	6  Press OK .*2		

• To exit the operation, press  any time.

*1 If you need correction, press **RIGHT** or **LEFT** to move cursor then clear a character by pressing **CLEAR**, and/or enter characters. Characters are cleared or added to the left of the flashing character. To enter characters, see Character Selection below.

*2 To continue storing another caller information, repeat the steps from **3**.









Character Selection

Keys	Number of times key is pressed								Keys	Number of times key is pressed				
	1	2	3	4	5	6	7	8		1	2	3	4	5
	#	[]	*	,	-	/	1		M	N	O	6	
	A	B	C	2						P	Q	R	S	7
	D	E	F	3						T	U	V	8	
	G	H	I	4						W	X	Y	Z	9
	J	K	L	5						Blank	0			





Character Table

A	B	C	D	E	F	G	H	I	J	K	L	M	N	O	P	Q	R	S	T	U	V	W	X	Y
A	B	C	D	E	F	G	H	I	J	K	L	M	N	O	P	Q	R	S	T	U	V	W	X	Y
Z	1	2	3	4	5	6	7	8	9	*	0	#	-	/	[]	,							
Z	1	2	3	4	5	6	7	8	9	*	0	#	-	/	[]	,							



Editing a Caller Information

1		2		3		4	The 1st digit of the desired phone number blinks.
	Press PHONEBOOK . ^{*1}		Search/Select desired item.		Select "EDIT".		
<Phone Number>							
5		6		AND/OR	Number	7	
	Move cursor.		Press CLEAR . ^{*2}		Edit the phone number. ^{*3}		Press OK .
<Name>							
8		9		AND/OR	Name	10	
	Move cursor.		Press CLEAR . ^{*2}		Edit the name. ^{*4}		Press OK .

Clearing a Caller Information

1				4	
	Press PHONEBOOK . ^{*1}	Search/Select desired item.	Search/Select "CLEAR".		Search/Select "YES". ^{*5}

Dialling with the Phonebook

1		2		3	
	Press PHONEBOOK . ^{*1}		Search desired item.		Press TALK .

• To exit the operation, press  any time.

*1 If there is no item stored in the phonebook, the display shows "NO ITEM".



*2 Digits are cleared to the left of the flashing digit.

*3 Digits are added to the left of the flashing digit. If you need to clear or add more than one digit, repeat the steps from **5**.

*4 Characters are added to the left of the flashing character. If you need to clear or add more than one character, repeat the steps from **8**.

*5 To continue clearing another caller information, repeat the steps from **2**.

8.5.2. Storing the Phone Number into the Phonebook When Pre-dialling

1	Phone Number ^{*1}	2		3		4	Name
			Press OK to store the number.		Press OK twice.		Enter name.
5							
	Press OK .						

• To exit the operation, press  any time.

*1 If you need correction, press **CLEAR**. Digit is cleared to the left, then enter numbers.

8.5.3. Storing the Number from the Redial/Caller List into the Phonebook

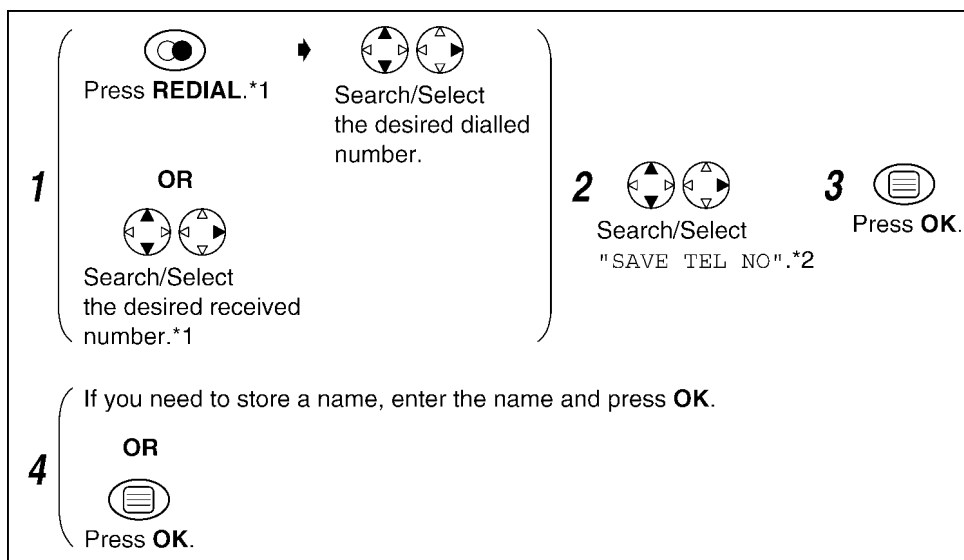

• To exit the operation, press any time.

*1 If there is no item stored in the redial/caller list, the display shows "NO ITEM".

*2 If you need correction, press **RIGHT** or **LEFT** to move cursor then clear a character by pressing **CLEAR**, and/or enter digits. Digits are cleared or added to the left of the flashing digit.

8.5.4. Hot Key (: Speed Dial)

You can assign the dialling buttons 1 through 9 as hot keys. You can choose 9 phone numbers from the phonebook.

Registering a Phone Number as a Hot Key

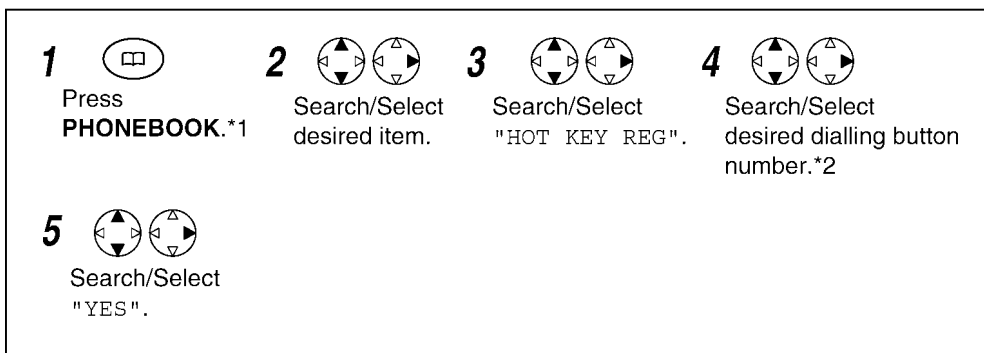

Dialling with Hot Key

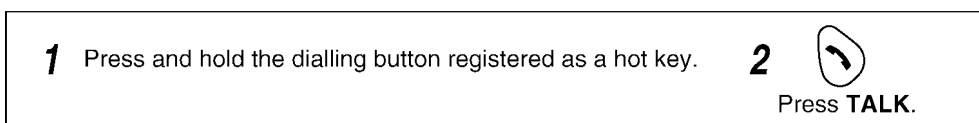

Clearing the Hot Key Registration



• To exit the operation, press any time.

*1 If there is no item stored in the phonebook, the display shows "NO ITEM".

*2 The number is flashing if the dialling button is already assigned as a hot key.

*3 Phonebook registration will be remained even hot key registration is cleared.

9 DISASSEMBLY INSTRUCTIONS

9.1. Base Unit

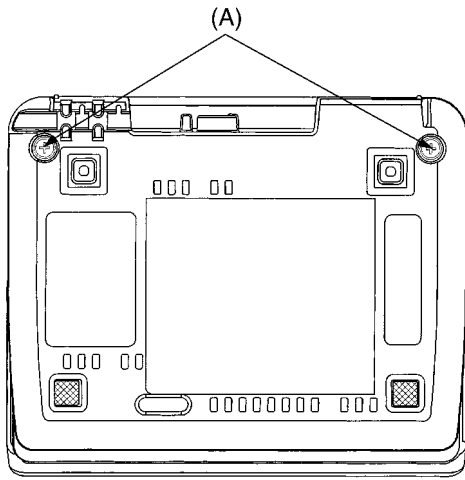

Fig. 1

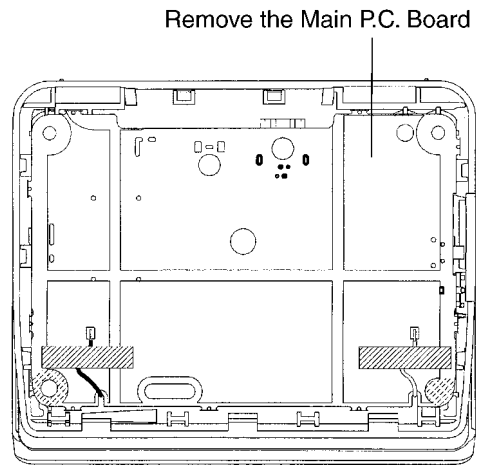

Fig. 2

Shown in Fig.-	To Remove	Remove
1	Lower Cabinet	Screws (2.6 × 12).....(A) × 2
2	Main P.C. Board	Main P.C. Board

9.2. Handset

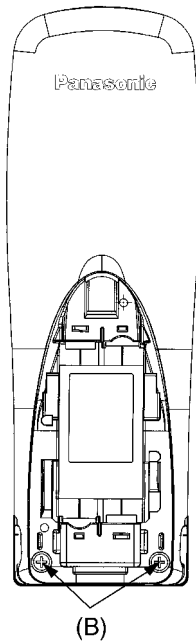

Fig. 3

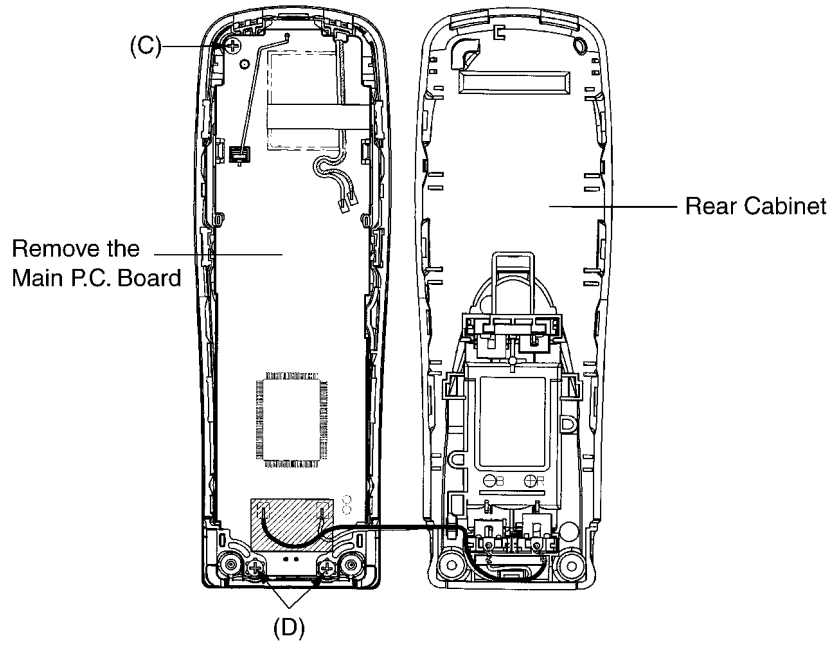
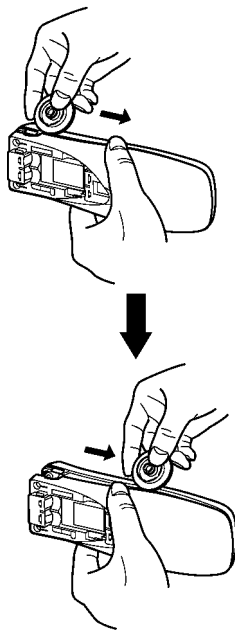
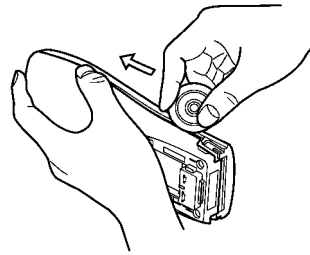

Fig. 5



Insert a JIG (PQDJ10006Y) between the Front and the Rear Cabinet, then pull it along the gap to open the Cabinet.



Likewise, open the other side of the Cabinet.

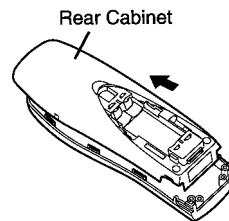

Remove the Rear Cabinet by pushing it upward.

Fig. 4

Shown in Fig.-	To Remove	Remove
3	Rear Cabinet	Screws (2 × 10).....(B) × 2
4	Rear Cabinet	Follow the procedure.
5	Main P.C. Board	Screw (2 × 8).....(C) × 1
		Screws (2 × 8).....(D) × 2
		Main P.C. Board

9.3. Charger Unit

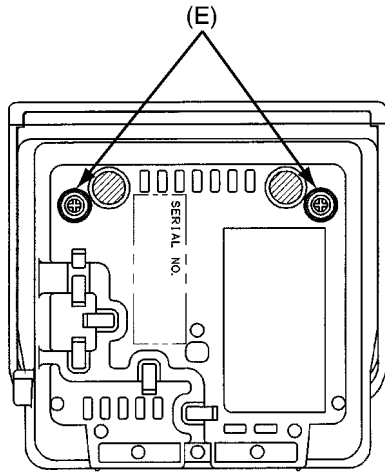

Fig. 6

Remove the Main P.C. Board

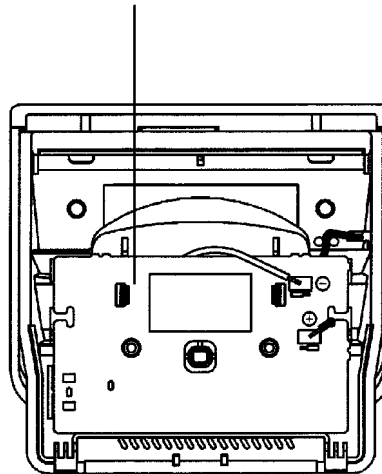

Fig. 7

Shown in Fig.-	To Remove	Remove
6	Lower Cabinet	Screws (2.6 × 14).....(E) × 2
7	Main P.C. Board	Main P.C. Board

10 ASSEMBLY INSTRUCTIONS

10.1. Warning When Constructing the Base Unit

CHG terminal is properly fit in the cabinet.

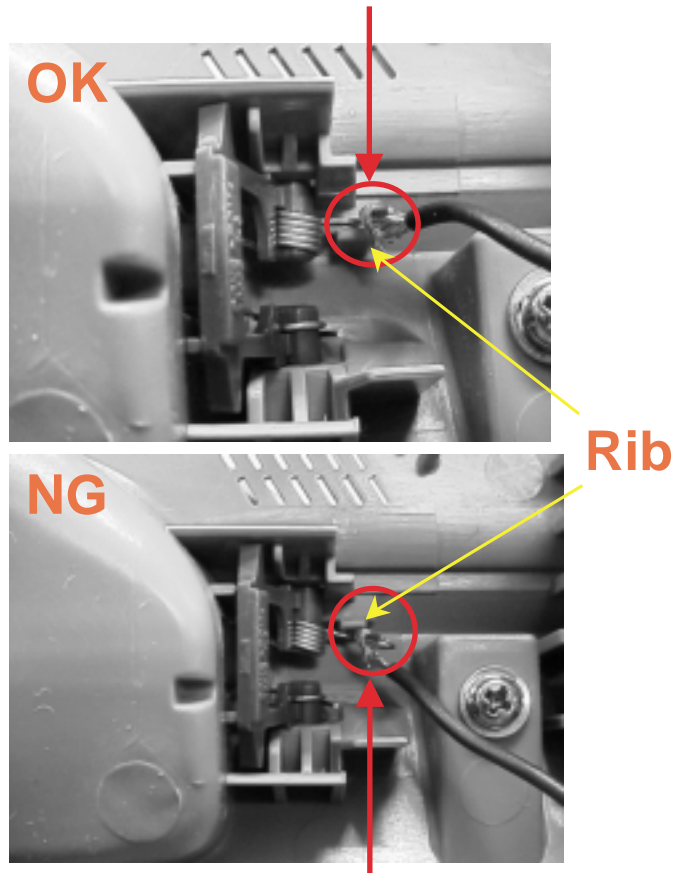

CHG terminal comes out of rib by pulling black lead wire when opening the cabinet and turning the PCB over. The terminal cannot have enough elastic force, cannot have good contact with handset, and it will result in charge problem.

11 TROUBLESHOOTING GUIDE

Flow Chart

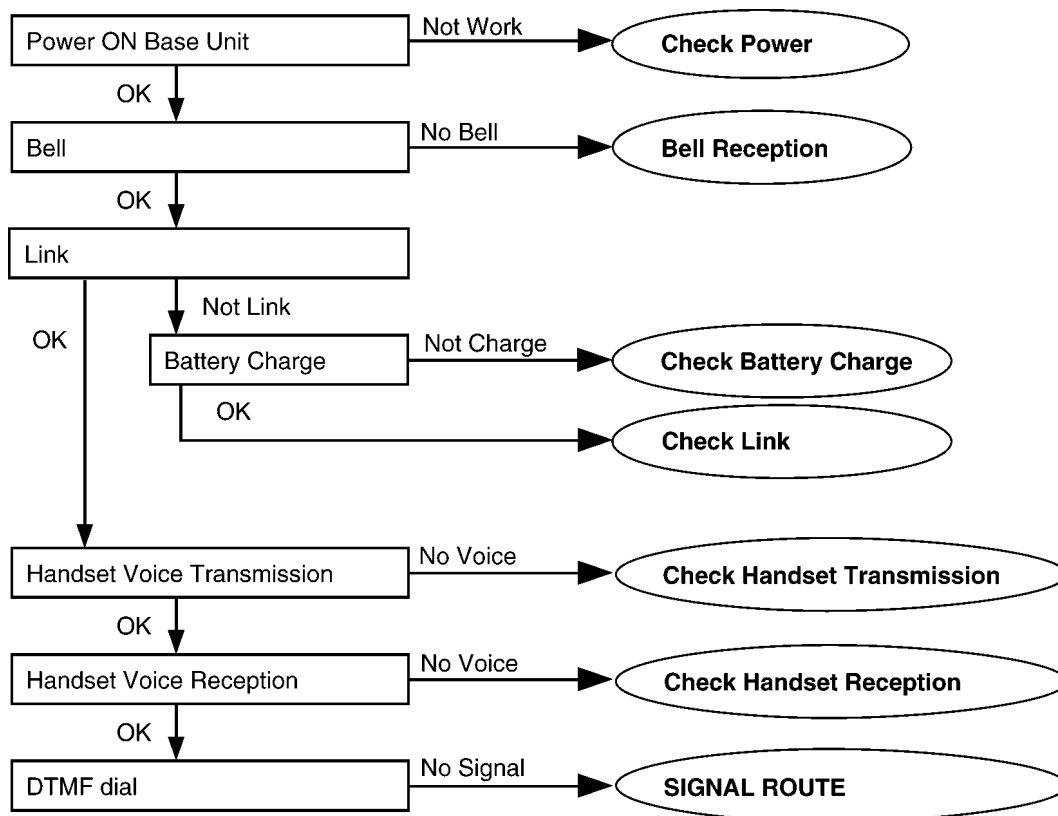

Cross Reference:

Check Power (P.31)

Bell Reception (P.36)

Check Battery Charge (P.32)

Check Link (P.33)

Check Handset Transmission (P.35)

Check Handset Reception (P.35)

SIGNAL ROUTE (P.58)

11.1. Check Power

11.1.1. Base Unit

Is the AC Adaptor inserted into AC outlet? (Check AC Adaptor's specification.)

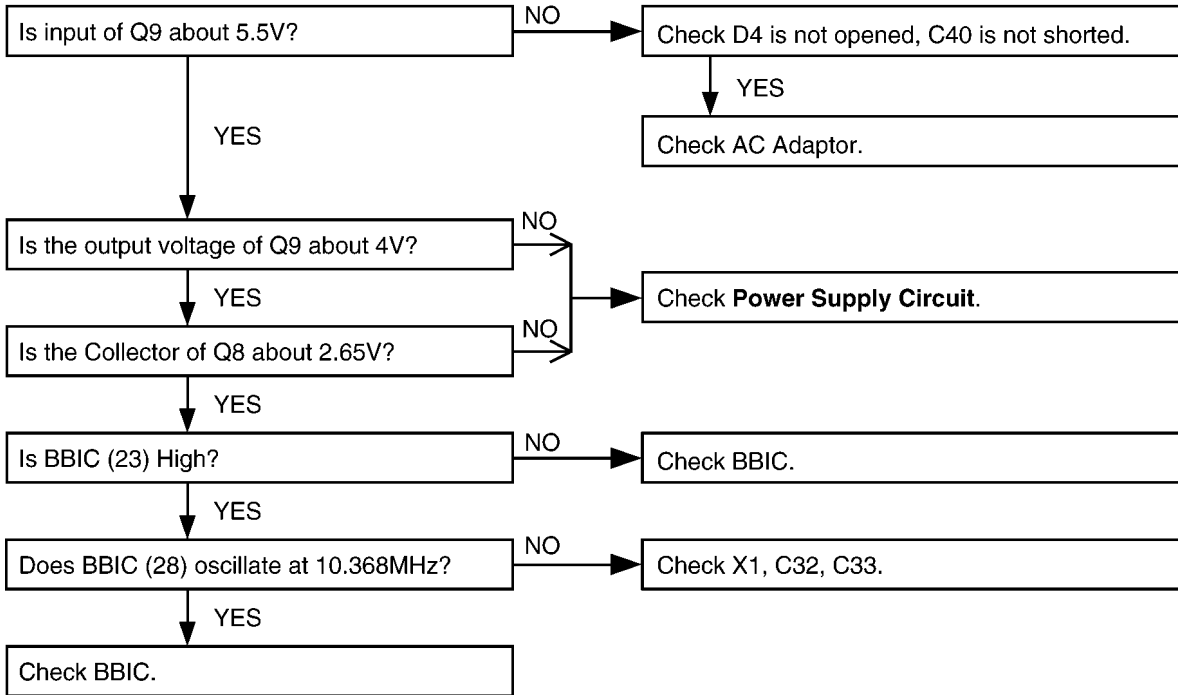

Cross Reference

Power Supply Circuit (P.54)

Note:

BBIC is IC2.

11.1.2. Handset

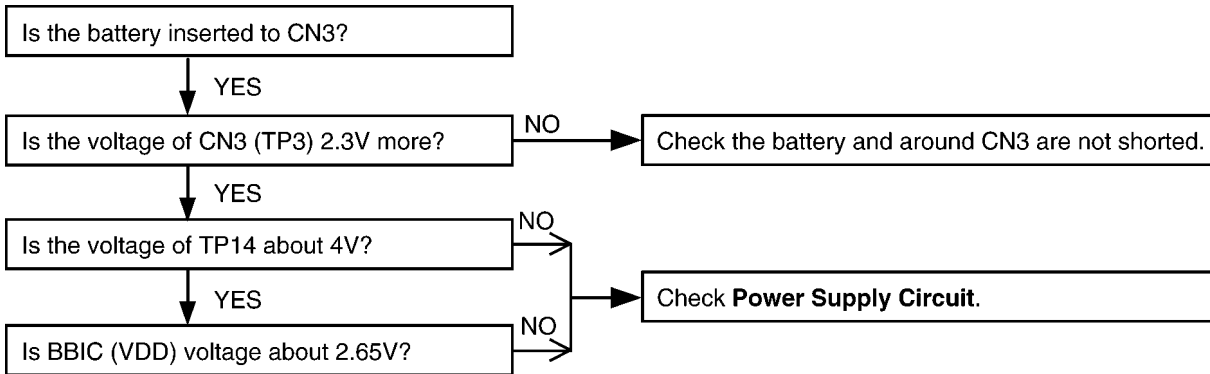

Cross Reference

Power Supply Circuit/Reset Circuit (P.57)

Note:

BBIC is IC1.

11.2. Check Battery Charge

11.2.1. Base Unit

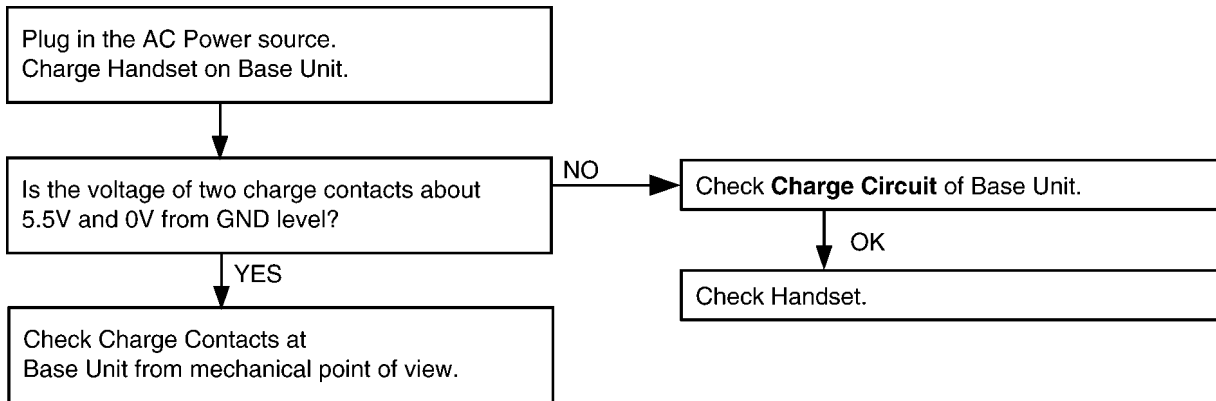

Cross Reference:

Charge Circuit (P.57)

11.2.2. Handset

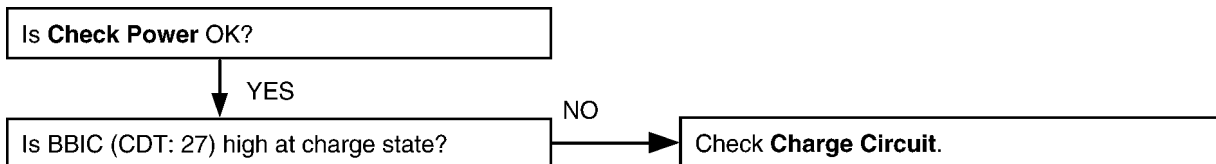

Cross Reference:

Check Power (P.31)

Charge Circuit (P.57)

Note:

BBIC is IC1.

11.2.3. Charger Unit

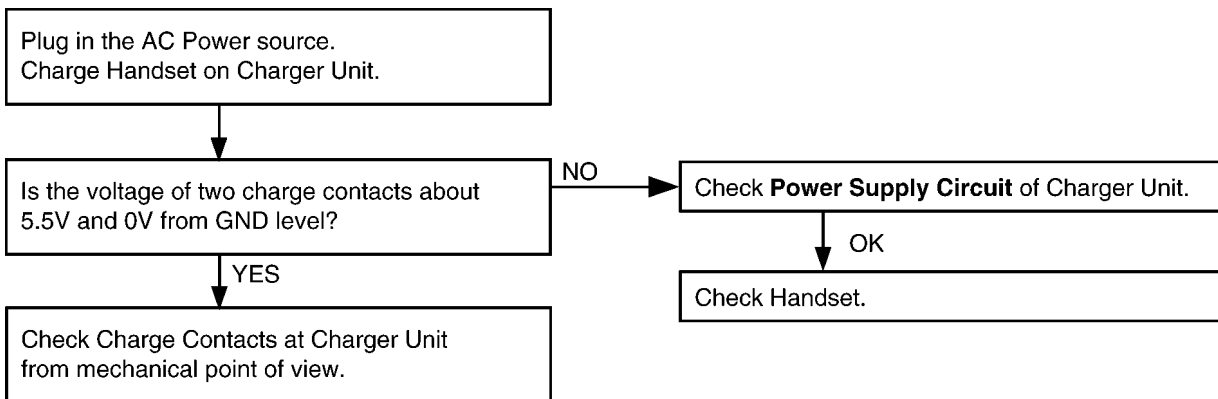

Cross Reference:

Power Supply Circuit (P.58)

11.3. Check Link

11.3.1. Base Unit

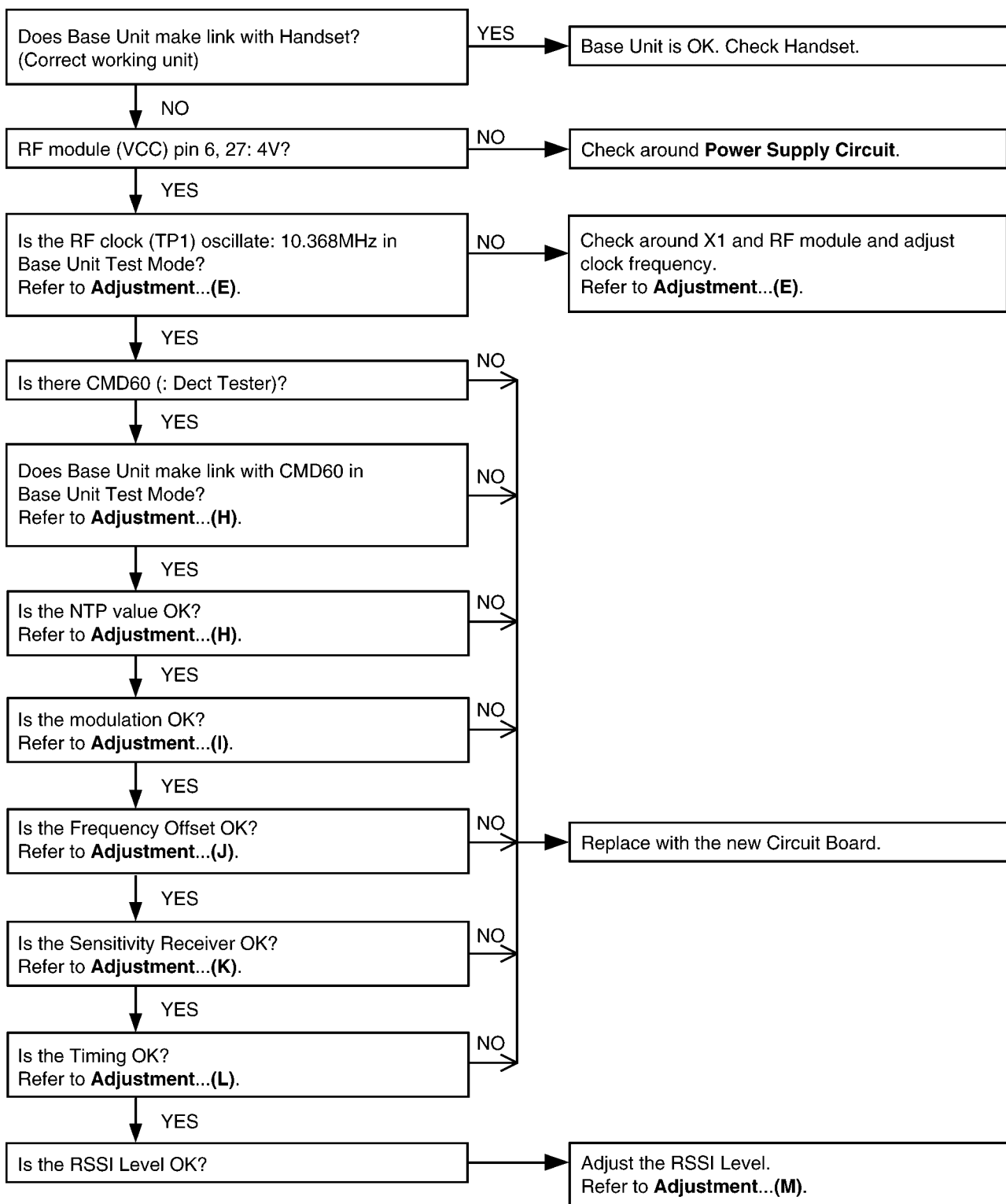

Cross Reference:

Power Supply Circuit (P.54)

Adjustment (Base Unit) (P.39)

11.3.2. Handset

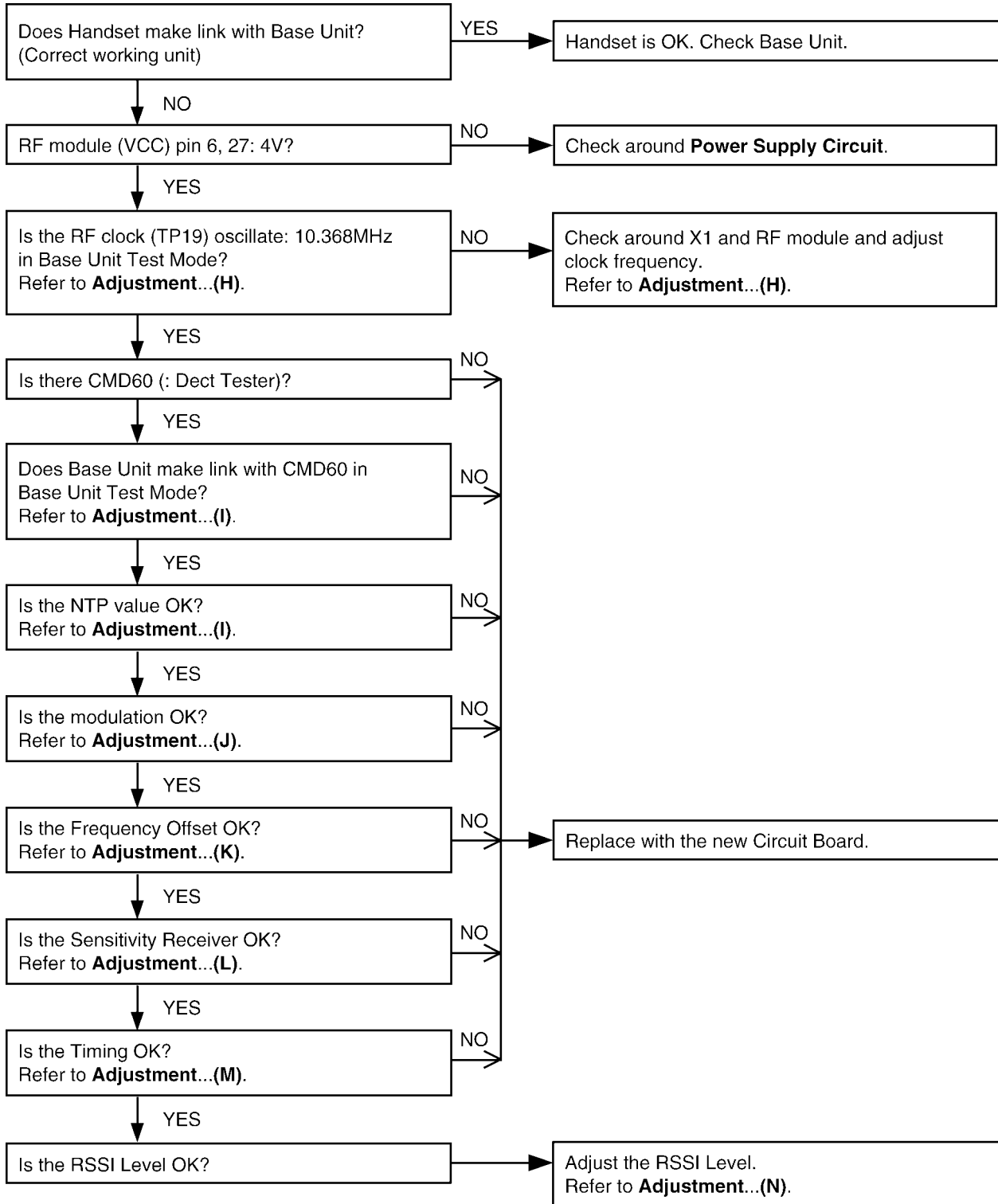

Cross Reference

Power Supply Circuit (P.54)

Adjustment (P.46)

11.4. Check Handset Transmission

Check MIC of Handset.

↓ OK

Check CDL TX (HANDSET) in **SIGNAL ROUTE**.

Cross Reference:

SIGNAL ROUTE (P.58)

11.5. Check Handset Reception

Check Handset Speaker in
HOW TO CHECK THE SPEAKER.

↓ OK

Check CDL RX (HANDSET) in **SIGNAL ROUTE**.

Cross Reference:

HOW TO CHECK THE HANDSET SPEAKER (P.50).

SIGNAL ROUTE (P.58)

11.6. Check Caller ID

Check Caller ID in **SIGNAL ROUTE**.

Cross Reference:

SIGNAL ROUTE (P.58)

11.7. Bell Reception

11.7.1. Base Unit

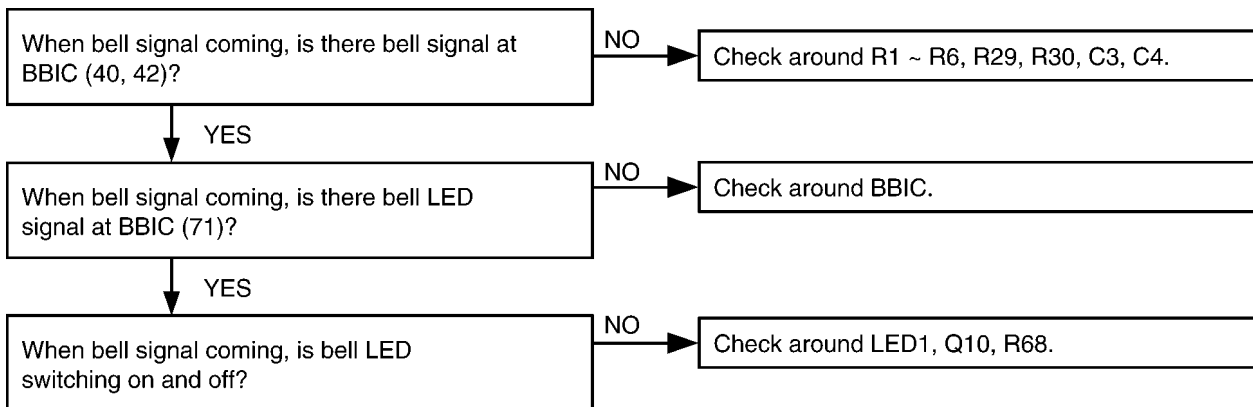

Note:

BBIC is IC2.

11.7.2. Handset

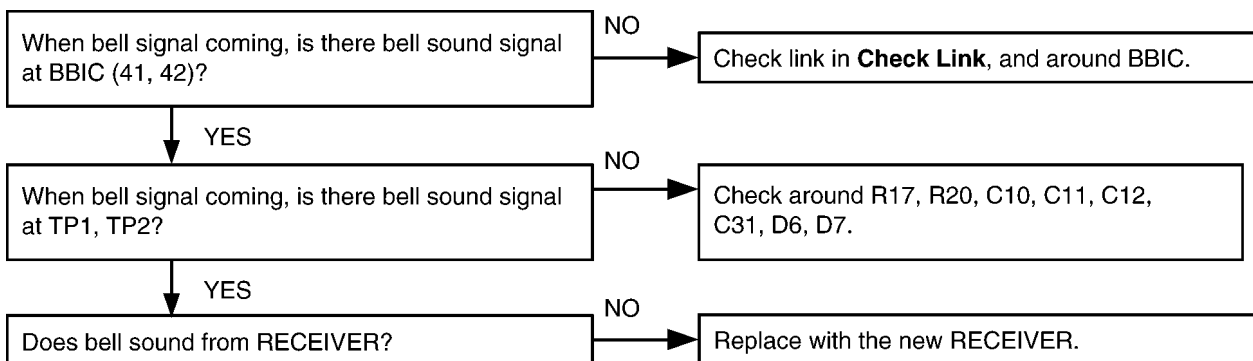

Cross Reference:

Telephone Line Interface (P.55)

Check Link (P.33)

Note:

BBIC is IC1.

12 CHECK PROCEDURE (BASE UNIT)

12.1. Preparation

12.1.1. Equipment Required

- DECT tester: Rohde & Schwarz, CMD 60 is recommended.
- Frequency counter: it must be precise to be able to measure 1Hz (precision; ± 4 ppm).
Hewlett Packard, 53131A is recommended.
- DC power: it must be able to output at least 1A current under 9V.
- Digital multi-meter (DMM): it must be able to measure voltage and current.
- Oscilloscope

12.1.2. JIGs and PC

- EEPROM serial JIGs
 1. I2C PCB: PQZZTCD705BX
 2. RS232C cable: PQZZ1CD705BX
 3. Clip cable: PQZZ2CD705BX
 4. DC cable: PQZZ3CD705BX
- PC which runs in DOS mode
- **Batch file** for setting: PQZZTCD410E

12.2. PC Setting

12.2.1. Connections

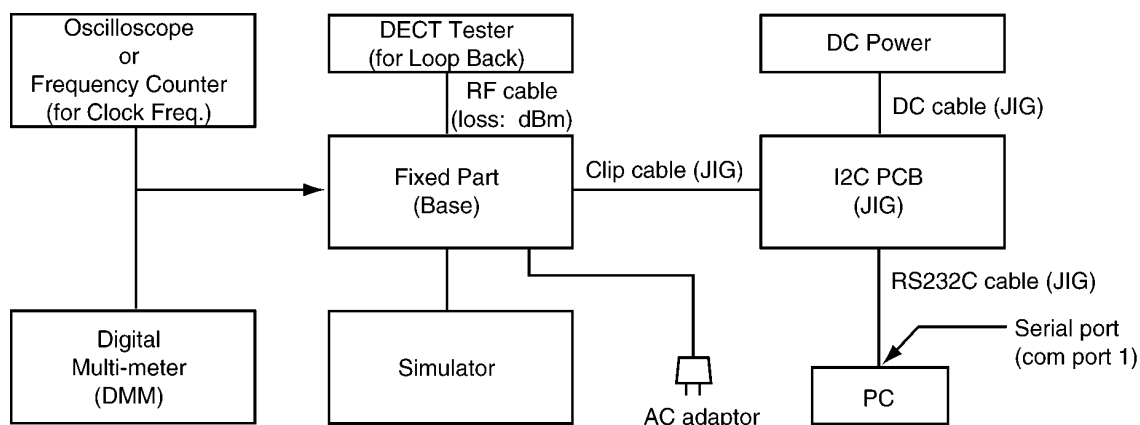

12.2.2. PC Setting

1. Open a window of MS-DOS mode from the start-up menu.
2. Change a directory to the one with "RTX_COM" contained.
3. Type "**SET RTX_COM=1**" from the keyboard (when COM port 1 is used for the connection).
4. Type "doskey".

Note:

See the table below for frequently used commands.

Command name	Function	Example
rdeeprom	Read the data of EEPROM	Type "rdeeprom 00 00 FF", and the data from address "00 00" to "FF" is read out.
readid	Read ID (RFPI)	Type "readid", and the registered ID is read out.
writeid	Write ID (RFPI)	Type "writeid 00 18 E0 0E 98", and the ID "0018 E0 0E 98" is written.
setfreq	adjust Frequency of RFIC	Type "setfreq nn nn".
hookoff	off-hook mode on Base	Type "hookoff".
hookon	on-hook mode on Base	Type "hookon".
Getchk	Read checksum	Type "getchk".
Wreeprom	write eeprom	Type "wreeprom 01 23 45". "01 23" is address and "45" is data to be written.
InitBsPIN.bat	Initial Base PIN to "0000"	Type "initBsPIN"

13 CHECK PROCEDURE (HANDSET)

13.1. Preparation

13.1.1. Equipment Required

- DECT tester: Rohde & Schwarz, CMD 60 is recommended.
- Frequency counter: it must be precise to be able to measure 1Hz (precision;±4ppm).
Hewlett Packard, 53131A is recommended.
- DC power: it must be able to output at least 1A current under 2.4V for Handset, 9V for JIG.
- Digital multi-meter (DMM): it must be able to measure voltage and current.
- Oscilloscope

13.1.2. JIGs and PC

- EEPROM serial JIGs
 1. I2C PCB: PQZZTCD705BX
 2. RS232C cable: PQZZ1CD705BX
 3. Clip cable: PQZZ2CD705BX
 4. DC cable: PQZZ3CD705BX
- PC which runs in DOS mode.
- **Batch file** for PC setting: PQZZTCD410E

13.2. PC Setting

13.2.1. Connections

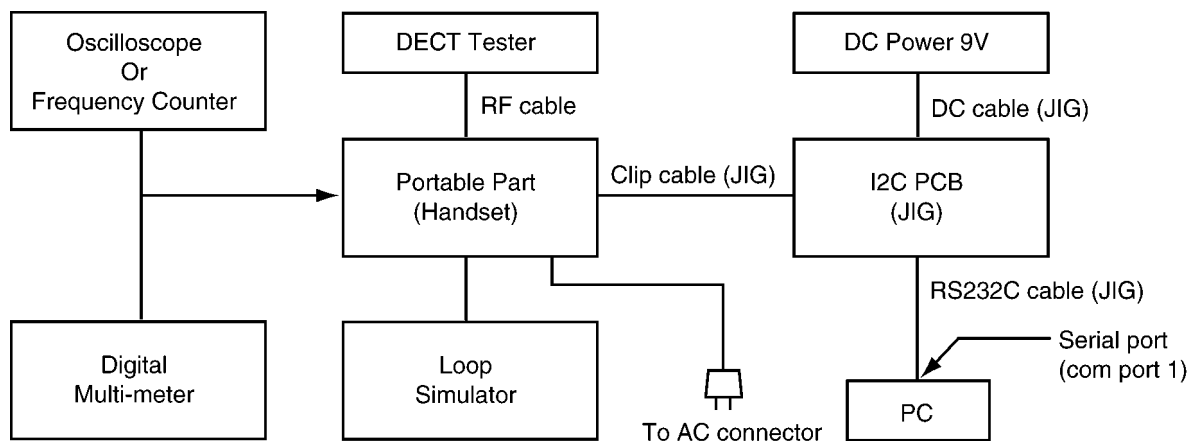

13.2.2. PC Setting

1. Open a window of MS-DOS mode from the start-up menu.
2. Change a directory to the one with "RTX_COM" contained.
3. Type "**SET RTX_COM=1**" from the keyboard (when COM port 1 is used for the connection).
4. Type "doskey".

Note:

See the table below for frequently used commands.

Command name	Function	Example
rdeeprom	Read the data of EEPROM	Type "rdeeprom 00 00 FF", and the data from address "00 00" to "FF" is read out.
readid	Read ID (RFPI)	Type "readid", and the registered ID is read out.
writeid	Write ID (RFPI)	Type "writeid 00 18 E0 0E 98", and the ID "0018 E0 0E 98" is written.
setfreq	adjust Frequency of RFIC	Type "setfreq nn nn".
Getchk	Read checksum	Type "getchk".
Wreeprom	write eeprom	Type "wreeprom 01 23 45". "01 23" is address and "45" is data to be written.

14 ADJUSTMENTS (BASE UNIT AND CHARGER UNIT)

If your unit have below symptoms, adjust or confirm each item using remedy column from the table.

Symptom	Remedy
The base unit does not respond to a call from handset.	Make adjustments in item (A)~(F), (I)~(M)
The base unit does not transmit or the transmit frequency is off.	Make adjustments in item (A)~(E), (H)~(J), (L)
The transmit frequency is off.	Make confirmation in item (A)~(E), (H)~(J), (L)
The transmit power output is low, and the operating distance between base unit and handset is less than normal.	Make confirmation in item (H), (K)
The reception sensitivity of base unit is low with noise.	Make confirmation in item (K)
The transmit level is high or low.	Make adjustments in item (O)
The reception level is high or low.	Make adjustments in item (N)
The unit does not link.	Make confirmation in item (A)~(M)
The unit cannot charge.	Make confirmation in item (P)

* : Refer to **Adjustment (Base Unit)** (P.39)

14.1. Adjustment (Base Unit)

Please follow the items below when BBIC or EEPROM or FLASH ROM are replaced.

	Items	Adjustment Point	Procedure*	Check or Replace Parts								
(A)	2.65V Supply Confirmation	-	1. Confirm that the voltage between TP187 and GND is $2.65V \pm 0.2V$.	IC2,Q8,C23, C24,C25,C27, C36,C37,C38, C46,C76,R33, C44,D5,C39, C41,R41,R42, Q9,C40,D4, X1,C32,C33								
(B)	4.0V Supply Confirmation	-	1. Confirm that the voltage between TP91 and GND is $4.0V \pm 0.2V$.	D4,C40,Q9, R41,R42,C41, D5,C69,C66, C67,L8,IC3, C65,C68,C61								
(C)	VBACK Status Confirmation	-	1. Confirm that the voltage between J102 and GND is $2.65V \pm 0.2V$.	IC2,Q8,C23, C24,C25,C27, C36,C37,C38, C46,C76,R33, C44,D5,C39, C41,R41,R42, Q9,C40,D4, X1,C32,C33, C45								
(D)*	BBIC Confirmation	-	1. BBIC Confirmation (Execute the command "getchk"). 2. Confirm the returned checksum value. Connection of checksum value and program number is shown below. ex.) <table border="1" style="margin-left: 40px;"> <thead> <tr> <th>checksum value</th> <th>program number</th> </tr> </thead> <tbody> <tr> <td>32BB</td> <td>D261ZA</td> </tr> <tr> <td>4D2B</td> <td>D261ZB</td> </tr> <tr> <td>5559</td> <td>D261ZC</td> </tr> </tbody> </table>	checksum value	program number	32BB	D261ZA	4D2B	D261ZB	5559	D261ZC	IC2,X1,C32, C33,IC4,R80, R84,C88,C89, R83
checksum value	program number											
32BB	D261ZA											
4D2B	D261ZB											
5559	D261ZC											
(E)*	BBIC Clock Adjustment	TP1	1. Execute the command "deactmac". 2. Execute the command "conttx". 3. Input Command "rdeeprom_00_00_02", then you can confirm the current value. 4. Adjust the frequency of TP1 executing the command "setfreq 00 xx (where xx is the value)" so that the reading of the frequency counter is $10.368000MHz \pm 3Hz$.	IC2,IC3,L1, C48,X1,C32, C33,C47								
(F)*	Hookswitch Check with DC Characteristics	-	1. Connect J1 (Telephone Socket) to Tel-simulator which is connected with 600 Ω . 2. Set line voltage to 48V at on-hook condition and line current to 40mA at off-hook condition of normal telephone. 3. Execute the command "hookoff" 4. Confirm that the line current is 40mA \pm 5mA. 5. Execute the command "hookon". 6. Confirm that the line current is 0mA + 0.2mA.	IC2,R7,R8, R9,R10,R77, Q2,Q3,D2, C1,C2,C52								

	Items	Adjustment Point	Procedure*	Check or Replace Parts
(G)*	DTMF Generator Confirmation	-	<ol style="list-style-type: none"> 1. Connect J1 (Telephone Socket) to DTMF tester. 2. Execute the command "hookoff" and "dtmf_up". 3. Confirm that the high frequency (1477.06Hz) group is $-3\text{dBm} \pm 2\text{dBm}$. 4. Execute the command "dtmf_lo". 5. Confirm that the low frequency (852.05Hz) group is $-6\text{dBm} \pm 2\text{dBm}$. 	IC2,R32,C22, R23,C90,C52, C14,C13,Q6, R22,R21,R19, R20,C12,D2, C1,C2,R77, D3,R12,Q2, R7,R8,R9, R10,Q3
(H)*	Transmitted Power Confirmation	-	<p>Remove the Antenna before starting step from 1 to 4.</p> <ol style="list-style-type: none"> 1. Configure the DECT tester (CMD60) as follows; <ul style="list-style-type: none"> <Setting> <ul style="list-style-type: none"> • Test mode: FP • Traffic Channel: 5 • Traffic Slot: 4 • Mode: Loopback • PMID: 0000 • Set the Cable Loss as 5dB. 2. Execute the command "testmode". 3. Initiate connection from DECT tester. ("set up connect") 4. Confirm that the NTP value at ANT is $20\text{dBm} \sim 25\text{dBm}$. 	IC2,IC3,L1, C43,C61,C68, C69,C48,C72, C66,C67,C65, C57,C73,L3, DA1,R66,R67, C55,C56,R78, R79,C54,C58, C80,R38,C81, C82,C83,C84, C85,L8,C91, C47
(I)	Modulatoin Check and Adjustment	ANT	<p>Follow steps 1 to 3 of (H) above.</p> <ol style="list-style-type: none"> 4. Confirm that the B-Field Modulation is $340\text{kHz/div} \sim 402\text{kHz/div}$ using data type Fig31. 5. Adjust the B-Field Modulation if required. (Execute the command "readmod" and "wrtmod xx", where xx is the value.) 	IC2,IC3,L1, C43,C61,C68, C69,C48,C72, C66,C67,C65, C57,C73,L3, DA1,R66,R67, C55,C56,R78, R79,C54,C58, C80,R38,C81, C82,C83,C84, C85,L8,C91 C47
(J)	Frequency Offset Confirmation	-	<p>Follow steps 1 to 3 of (H) above.</p> <ol style="list-style-type: none"> 4. Confirm that the frequency offset is $< \pm 40\text{kHz}$. 	IC2,IC3,L1, C43,C61,C68, C69,C48,C72, C66,C67,C65, C57,C73,L3, DA1,R66,R67, C55,C56,R78, R79,C54,C58, C80,R38,C81, C82,C83,C84, C85,L8,C91, C47
(K)	Sensitivity Receiver Confirmation	-	<p>Follow steps 1 to 3 of (H) above.</p> <ol style="list-style-type: none"> 4. Set DECT tester power to -88dBm. 5. Confirm that the BER is $< 1000\text{ppm}$. 	IC2,IC3,L1, C43,C61,C68, C69,C48,C72, C66,C67,C65, C57,C73,L3, DA1,R66,R67, C55,C56,R78, R79,C54,C58, C80,R38,C81, C82,C83,C84, C85,L8,C91, C47
(L)	Timing Confirmation	-	<p>Follow steps 1 to 3 of (H) above.</p> <ol style="list-style-type: none"> 4. Confirm that the Timing accuracy is $< \pm 5.0\text{ppm}$. 	IC2,IC3,L1, C43,C61,C68, C69,C48,C72, C66,C67,C65, C57,C73,L3, DA1,R66,R67, C55,C56,R78, R79,C54,C58, C80,R38,C81, C82,C83,C84, C85,L8,C91, C47

	Items	Adjustment Point	Procedure*	Check or Replace Parts
(M)*	RSSI Level Confirmation	-	<p>Follow steps 1 to 3 of (H) above.</p> <p>4..Set DECT tester power to -88dBm.</p> <p>5.Execute the command "readrssi".</p> <p>6. Confirm: 23 < returned value < 45 (hex)</p>	IC2,IC3,L1, C43,C61,C68, C69,C48,C72, C66,C67,C65, C57,C73,L3, DA1,R66,R67, C55,C56,R78, R79,C54,C58, C80,R38,C81, C82,C83,C84, C85,L8,C91, C47
(N)*	Receive Audio Check and Adjustment	ANT J1	<p>1. Configure the DECT tester (CMD60) as follows;</p> <p><Setting></p> <ul style="list-style-type: none"> • Test mode: FP • Mode: Normal • PMID: 0000 <p>2. Execute the command "testmode".</p> <p>3. Initiate connection from DECT tester.</p> <p>4. Execute the command "hookoff".</p> <p>5. Execute the command "openau".</p> <p>6. Connect J1 (Telephone Socket) to Tel-simulator which is connected with 600 Ω.</p> <p>7. Set line voltage to 48V and line current to 40mA.</p> <p>8. Connect DECT tester to Tel-simulator.</p> <p>9. Input audio signal (200mVrms/1kHz tone) to Tel-simulator.</p> <p><DECT tester setting></p> <ul style="list-style-type: none"> • Scramble: On • AF Gen to ADPCM: Off • AF Meter Input: ADPCM • AF Gen Frequency: 1000Hz • AF Gen Level: 200mVrms <p>10. Confirm hearing tone: 390mVrms ± 85mVrms</p> <p>11. Adjust audio level if required. (Make sure current value using "getmicgain". And then execute the command "setmicgain xx", where xx is the value.)</p> <p>12. Confirm that the B-field audio distortion with DECT tester is < 5 %.</p>	IC2,C21,R31, C20,C11,R18, R16,D3,R12, Q2,R7,R8, Q3,R9,R10, D2,C1,C2, R77,IC3,L1, C43,C61,C68, C69,C48,C72, C66,C67,C65, C57,C73,L3, DA1,R66,R67, C55,C56,R78, R79,C54,C58, C80,R38,C52, C81,C82,C83, C84,C85,C91, L8,C47

	Items	Adjustment Point	Procedure*	Check or Replace Parts
(O)*	Transmit Audio Check and Adjustment	ANT J1	1. Configure the DECT tester (CMD60) as follows; <Setting> <ul style="list-style-type: none"> • Test mode: FP • Mode: Normal • PMID: 0000 2. Execute the command "testmode". 3. Initiate connection from DECT tester. 4. Execute the command "hookoff". 5. Execute the command "openau". 6. Connect J1 (Telephone Socket) to Tel-simulator which is connected with 600 Ω. 7. Set line voltage to 48V and line current to 40mA. 8. Input audio signal (30mVrms/1kHz tone) to DECT tester. <DECT tester setting> <ul style="list-style-type: none"> • Scramble: On • AF Gen to ADPCM: On • AF Meter Input: AF Voltm • AF Gen Frequency: 1000Hz • AF Gen Level: 30mVrms 9. Confirm hearing tone: 300mVrms ± 50mVrms. 10. Adjust audio level if required. (Make sure current value using "getspkrgain". And then execute the command "setspkrgain xx", where xx is the value.) 11. Confirm that the audio distortion at 600R of Tel-simulator is < 5 %.	IC2,R32,C22, R23,C14,C13, R22,R21,Q6, R18,R19,R20, C12,D2,C1, C2,R77,R16, D3,R12,Q2, R7,R8,R9, R10,Q3,IC3, L1,C43,C61, C68,C69,C48, C72,C66,C67, C65,C57,C73, L3,DA1,R66, R67,C55,C56, R78,R79,C54 C58,C80,R38 C90,C52,C81, C82,C83,C84, C85,C91,L8 C47
(P)	Charging Check	-	1. Connect Charge Contact 12Ω/2W register between charge+ and charge-. 2. Measure and confirm voltage across the register is 2.3V ± 0.2V.	D4,R43,R44

Note:

After the measuring, sock up the solder of TP.

* : **PC Setting** (P.37) is required beforehand.

The connection of adjustment equipment are as shown in **Adjustment Standard (Base Unit)** (P.43).

14.2. Adjustment Standard (Base Unit)

When connecting the Simulator Equipments for checking, please refer to below.

14.2.1. Component View

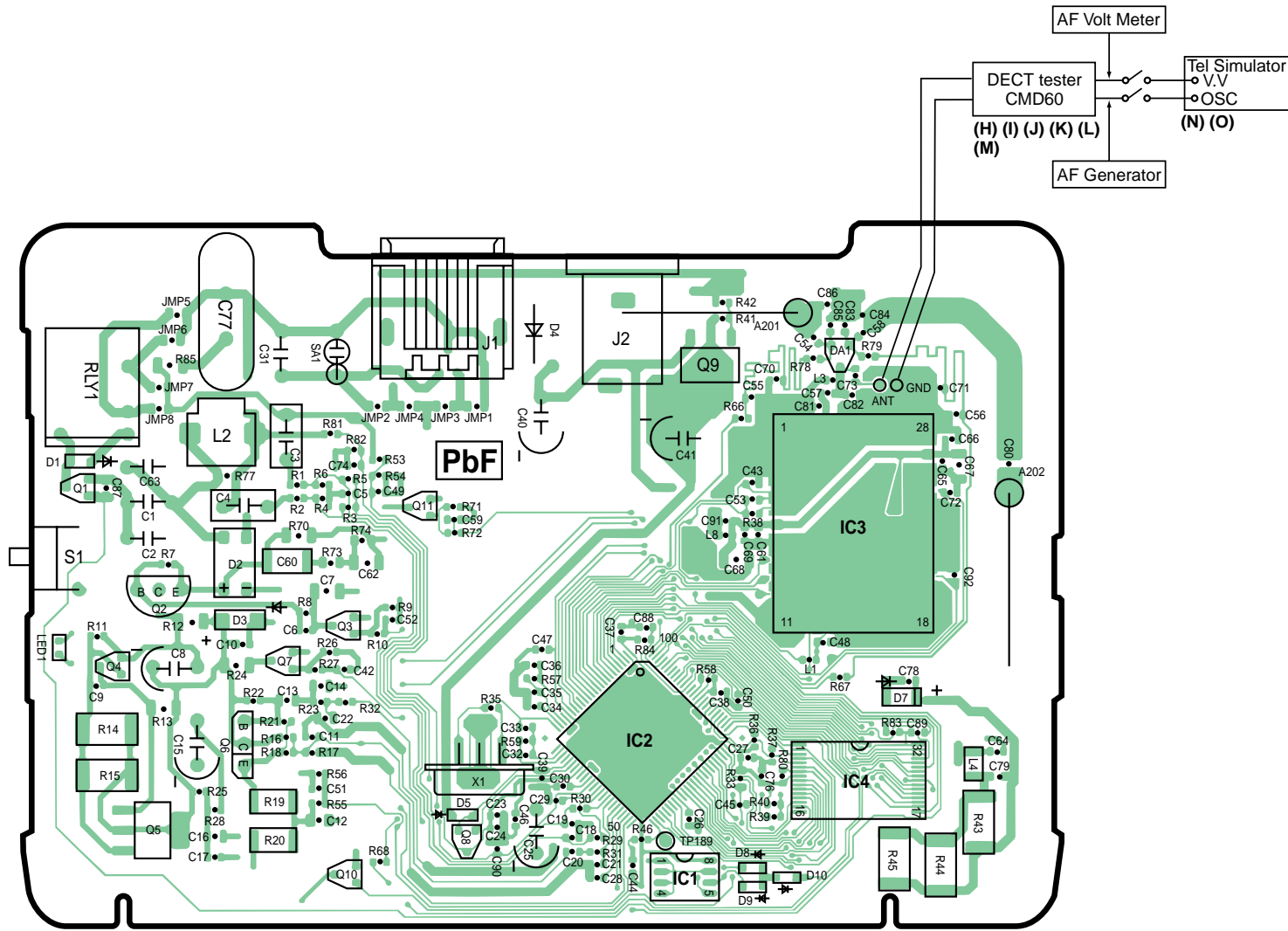

Note:

(H) - (O) is referred to **ADJUSTMENTS (BASE UNIT AND CHARGER UNIT)** (P.39)

14.2.2. Flow Solder Side View

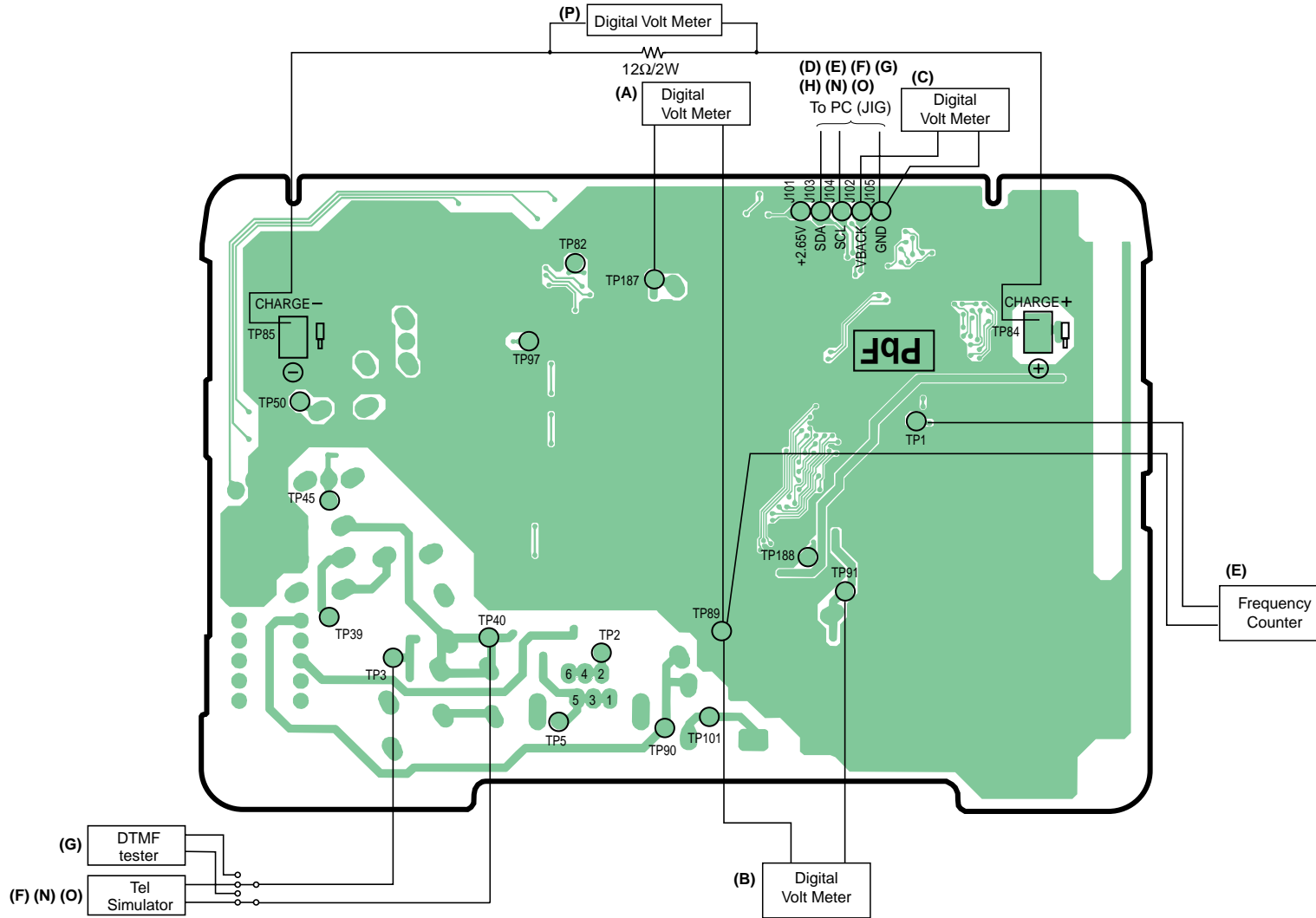

Note:

(A) - (P) is referred to **ADJUSTMENTS (BASE UNIT AND CHARGER UNIT)** (P.39)

14.3. Adjustment (Charger Unit)

	Items	Adjustment Point	Procedure	Check or Replace Parts
(A)	Charging Check	-	1. Connect Charge Contact 12Ω/2W resistor between charge+ and charge-. 2. Measure and confirm voltage across the register is 2.7V ± 0.2V.	D1,R1,R2

Note:

After the measuring, sock up the solder of TP.

The connection of adjustment equipment are as shown in **Adjustment Standard (Charger Unit)** (P.45).

14.4. Adjustment Standard (Charger Unit)

When connecting the Simulator Equipments for checking, please refer to below.

14.4.1. Flow Solder Side View

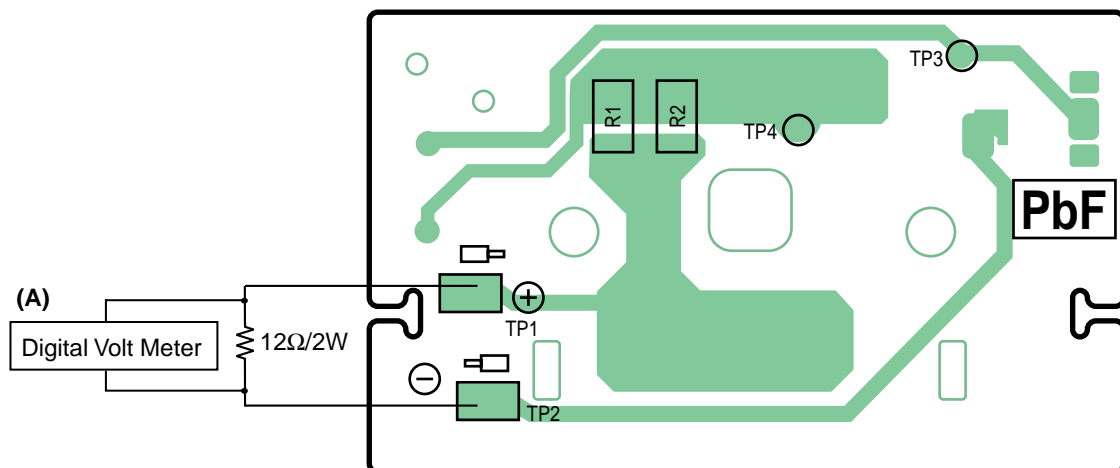

Note:

(A) is referred to **ADJUSTMENTS (BASE UNIT AND CHARGER UNIT)** (P.39)

15 ADJUSTMENTS (HANDSET)

If your unit have below symptoms, adjust or confirm each item using remedy column from the table.

Symptom	Remedy
The movement of Battery Low indicator is wrong.	Make confirmation in item (A)~(C), (F)~(G)
The handset does not respond to a call from base unit.	Make adjustments in item (A)~(C), (H), (J)~(N)
The handset does not transmit or the transmit frequency is off.	Make adjustments in item (A)~(C), (H)~(K), (M)
The transmit frequency is off.	Make confirmation in item (A)~(C), (H)~(K), (M)
The transmit power output is low, and the operating distance between base unit and handset is less than normal.	Make confirmation in item (I), (L)
The reception sensitivity of base unit is low with noise.	Make confirmation in item (L)
Does not link between base unit and handset.	Make confirmation in item (A)~(C), (H)~(N)
The reception level is high or low.	Make adjustments in item (O)
The transmit level is high or low.	Make adjustments in item (P)

* : Refer to **Adjustment** (P.46)

15.1. Adjustment

Please follow the items below when BBIC or EEPROM are replaced.

Items	Adjustment Point	Procedure*	Check or Replace Parts								
(A) 4.0V Supply Confirmation	-	1. Confirm that the consumption current is < 200mA , that is, there is no short circuit. 2. Confirm that the voltage between TP14 and GND is 4.1V ± 0.2V.	IC1,F1,R21, R4,C33,L2, D1,C15,C2, C14,Q1,R3, R2,D2,R22, C26,X1,C16, C17								
(B) VBACK Status Confirmation	-	1. Confirm that the voltage between TP18 and GND is 0V ± 0.4V.	IC1,F1,R21, R4,C33,L2, D1,C15,C2, C14,Q1,R3, R2,D2,R22, C26,R16,X1, C16,C17								
(C) BBIC Confirmation	-	1. BBIC Confirmation (Execute the command "getchk"). 2. Confirm the returned checksum value. Connection of checksum value and program number is shown below. ex.) <table border="1" style="margin-left: 40px;"> <thead> <tr> <th>checksum value</th> <th>program number</th> </tr> </thead> <tbody> <tr> <td>D8C3</td> <td>D241ZB</td> </tr> <tr> <td>A00E</td> <td>D241ZC</td> </tr> <tr> <td>AA80</td> <td>D241ZD</td> </tr> </tbody> </table>	checksum value	program number	D8C3	D241ZB	A00E	D241ZC	AA80	D241ZD	IC1,X1,C16, C17
checksum value	program number										
D8C3	D241ZB										
A00E	D241ZC										
AA80	D241ZD										
(D) Charge Control Check & Charge Current Monitor Confirmation	-	1. Apply 6V between TP5(+) and TP6(-) with current limit of PSU to 200mA. 2. Confirm that the charge current is ON/OFF. 3. SW to decrease current limit of PSU to 100mA. 4. Confirm that the charge current is stable.	IC1,D4,L4, L5,Q2,Q3, R6,D2,R22, C26,F1,R21, R4,C33								
(E)* Charge Detection (OFF) Confirmation	-	1. Stop supplying 6V to TP5(+) and TP6(-). 2. Execute the command "charge". 3. Confirm that the returned value is 0x00 (hex).	IC1,D4,L4, L5,Q2,Q3, R6,D2,R22, C26,F1,R21, R4,C33								
(F)* Battery Monitor Confirmation	-	1. Apply 2.3V ± 0.005V between TP3(+) and TP4(-). 2. Execute the command "readbatt". 3. Confirm: 98 < returned value < A8 (Hex) 4. Execute the command "WRTBAT2 XX". XX: (returned value) - 06 (Hex)	IC1,D4,L4, L5,Q2,Q3, R6,D2,R22, C26,F1,R21, R4,C33								
(G) Battery low Confirmation	-	1. Apply 2.40V between TP3(+) and TP4(-). 2. Confirm that there is no Speaker sound (Battery low alarm). 3. Apply 2.20V between TP3(+) and TP4(-). 4. Confirm that there is Speaker sound (Battery low alarm).	IC1,F1,R21, R4,C33,C12, C31,R17,R20, C10,C11,D6, D7								
(H)* BBIC Clock Adjustment	TP19	1. Execute the command "contx". 2. Adjust the frequency of TP19 executing the command "setfreq 00 xx (where xx is the value)" so that the reading of the frequency counter is 10.368000MHz ± 3Hz.	IC1,L3,C57, IC3,X1,C16, C17								

	Items	Adjustment Point	Procedure*	Check or Replace Parts
(I)*	Transmitted Power Confirmation	TP15	<p>Remove the Antenna before starting step from 1 to 5.</p> <p>1. Configure the DECT tester(CMD60) as follows;</p> <p><Setting></p> <ul style="list-style-type: none"> • Test mode: PP • RFPI: 0102030405 • Traffic Channel: 5 • Traffic Slot: 4 • Mode: Loopback <p>2. Execute the command "testmode".</p> <p>3. Execute the command "regcmd60"</p> <p>4. Initiate connection from DECT tester.</p> <p>5. Confirm that the NTP value at A201 (TP15) is 20dBm ~ 25dBm</p>	IC1,IC3,C54, C66,C60,L3, C57,C55,C56, C62,R23,R24, C63,C64,C65, R18
(J)	Modulatoion Check and Adjusment	TP15	<p>Follow steps 1 to 4 of (I) above.</p> <p>5. Confirm that the B-Field Modulation is 340kHz/div ~ 402kHz/div using data type Fig31.</p> <p>6. Adjust the B-Field Modulation if required. (Execute the command "Readmod" and "Writemod xx", where xx is the value.)</p>	IC1,IC3,C54, C66,C60,L3, C57,C55,C56, C62,R23,R24, C63,C64,C65, R18
(K)	Frequency Offset Confirmation	-	<p>Follow steps 1 to 4 of (I) above.</p> <p>5. Confirm that the frequency offset is $\leq \pm 40$kHz.</p>	IC1,IC3,C54, C66,C60,L3, C57,C55,C56, C62,R23,R24, C63,C64,C65, R18
(L)	Sensitivity Receiver Confirmation	-	<p>Follow steps 1 to 4 of (I) above.</p> <p>5. Set DECT tester power to -88dBm.</p> <p>6. Confirm that the BER is < 1000ppm.</p>	IC1,IC3,C54, C66,C60,L3, C57,C55,C56, C62,R23,R24, C63,C64,C65, R18
(M)	Timing Confirmation	-	<p>Follow steps 1 to 4 of (I) above.</p> <p>5. Confirm that the Timing accuracy is $\leq \pm 10$ppm.</p>	IC1,IC3,C54, C66,C60,L3, C57,C55,C56, C62,R23,R24, C63,C64,C65, R18
(N)*	RSSI Level Confirmation	-	<p>Follow steps 1 to 4 of (I) above.</p> <p>5. Set DECT tester power to -88dBm.</p> <p>6. Execute the command "readrssi"</p> <p>7. Confirm that the returned value is $0x34 \pm A$ (hex).</p>	IC1,IC3,C54, C66,C60,L3, C57,C55,C56, C62,R23,R24, C63,C64,C65, R18
(O)*	Receive Audio Check and Confirmation	TP15	<p>1. Configure the DECT tester (CMD60) as follows;</p> <p><Setting></p> <ul style="list-style-type: none"> • Test mode: PP • Mode: Nomal • RFPI: 0102030405 <p>2. Execute the command "testmode".</p> <p>3. Execute the command "regcmd60"</p> <p>4. Initiate connection from DECT tester.</p> <p>5. Execute the command "openaudio".</p> <p>6. Confirm that the value of EEPROM address "F3F" is "02". (If the value is not "02 (by User)", set "02" and power off and power on, and return to clause 2.)</p> <p>7. Input audio signal (50mVrms/1kHz tone) from DECT tester.</p> <p><DECT tester setting></p> <ul style="list-style-type: none"> • Scramble: On • AF Gen to ADPCM: On • AF Meter Input: AF Voltm • AF Gen Frequency: 1000Hz • AF Gen Level: 50mVrms <p>8. Confirm hearing tone: 300mV \pm 250mV (Just check Audio path)</p> <p>9. Confirm that the audio distortion with DECT tester is < 5 %.</p>	IC1,C12,C31, R17,R20,C10, C11,D7,D6, IC3,C54,C66, C60,L3,C57, C55,C56,C62, R23,R24,C63, C64,C65,R18

	Items	Adjustment Point	Procedure*	Check or Replace Parts
(P)	Transmit Audio Check and Confirmation	TP15	1. Configure the DECT tester (CMD60) as follows; <Setting> <ul style="list-style-type: none"> • Test mode: FP • Mode: Normal • RFPI: 0102030405 2. Execute the command "testmode". 3. Execute the command "regcmd60". 4. Initiate connection from DECT tester. 5. Execute the command "openaudio". 6. Confirm that the value of EEPROM address "F3F" is "02". (If the value is not "02 (by User)", set "02" and power off and power on, and return to clause 2.) 7. Input audio signal (30mVrms/1kHz tone) to DECT tester. <DECT tester setting> <ul style="list-style-type: none"> • Scramble: On • AF Gen to ADPCM: Off • AF Meter Input: ADPCM • AF Gen Frequency: 1000Hz • AF Gen Level: 30mVrms 8. Confirm hearing tone: 300mV ± 250mV (Just check Audio path) 9. Confirm that the audio distortion with DECT tester is < 5 %.	IC1,C8,R7, R8,C6,C7, C5,R5,R1, C4,IC3,C54, C66,C60,L3, C57,C55,C56, C62,R23,R24, C63,C64,C65, R18

Note:

After the measuring, sock up the solder of TP.

* : **PC Setting** (P.38) is required beforehand.

The connection of adjustment equipment are as shown in **Adjustment Standard (Handset)** (P.49).

15.2. Adjustment Standard (Handset)

When connecting the Simulator Equipments for checking, please refer to below.

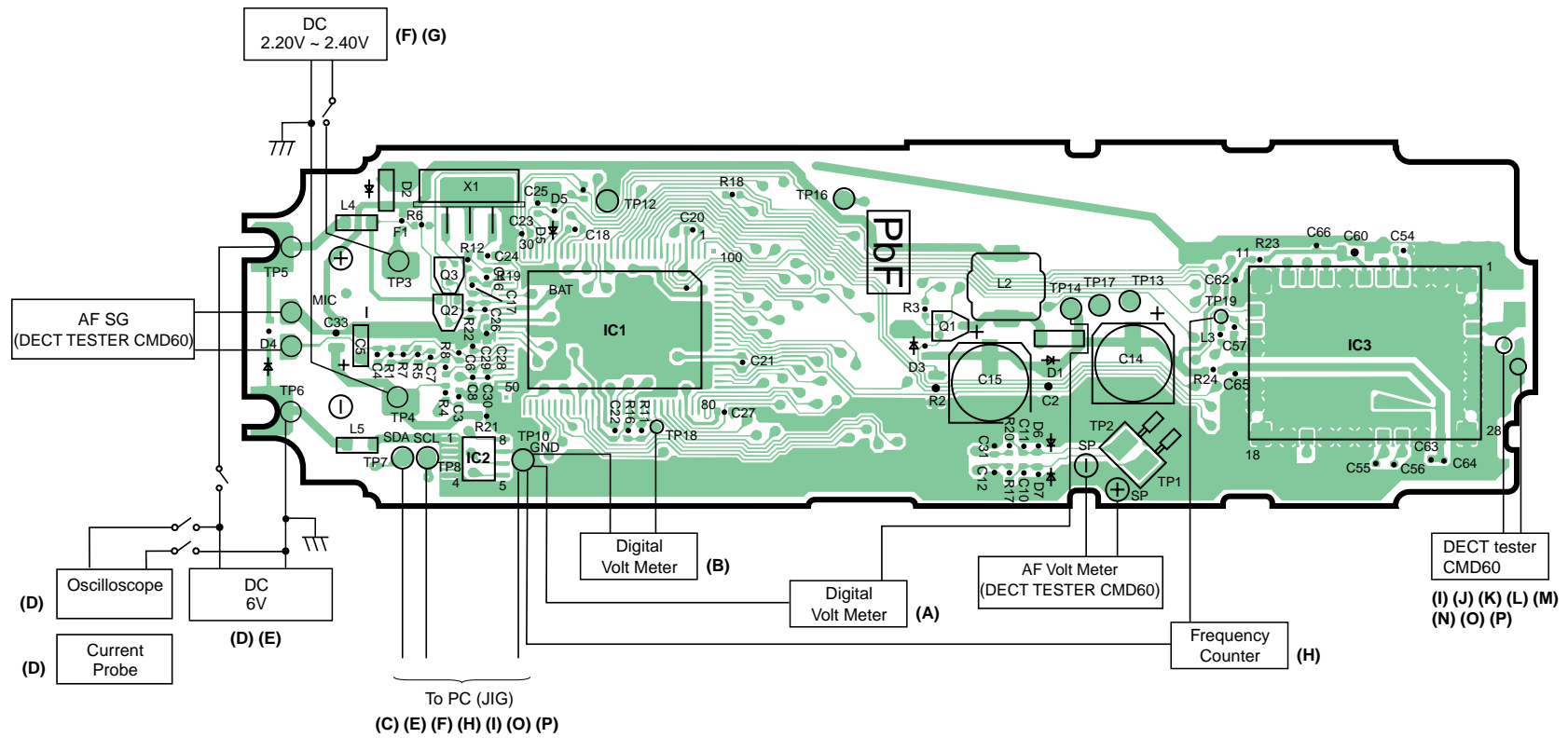

Note:

(A) - (P) is referred to **ADJUSTMENTS (HANDSET)** (P.46)

16 RF SPECIFICATION

16.1. Base Unit

Item	Value	Refer to -. *	Remarks
TX Power	More than 20 dBm ~ 25 dBm	Adjustment (Base Unit) (H)	
Modulation	340 kHz/div ~ 402 kHz/div	Adjustment (Base Unit) (I)	Data type: Fig31
Frequency Offset	-40 kHz ~ +40 kHz	Adjustment (Base Unit) (J)	
RX Sensitivity	< 1000 ppm	Adjustment (Base Unit) (K)	
Timing Accuracy	< ± 5.0 ppm	Adjustment (Base Unit) (L)	
RSSI Level	0x34 hex ± A hex	Adjustment (Base Unit) (M)	

* : Refer to **Adjustment (Base Unit)** (P.39)

16.2. Handset

Item	Value	Refer to -. **	Remarks
TX Power	More than 20 dBm ~ 25 dBm	Adjustment (Base Unit) (I)	
Modulation	340 kHz/div ~ 402 kHz/div	Adjustment (Base Unit) (J)	Data type: Fig31
Frequency Offset	-40 kHz ~ +40 kHz	Adjustment (Base Unit) (K)	
RX Sensitivity	< 1000 ppm	Adjustment (Base Unit) (L)	
Timing Accuracy	< ± 10 ppm	Adjustment (Base Unit) (M)	
RSSI Level	0x34 hex ± A hex	Adjustment (Base Unit) (N)	

** : Refer to **Adjustment** (P.46)

17 HOW TO CHECK THE HANDSET SPEAKER

1. Prepare the digital voltmeter, and set the selector knob to ohm meter.
2. Put the probes at the speaker terminals as shown below.

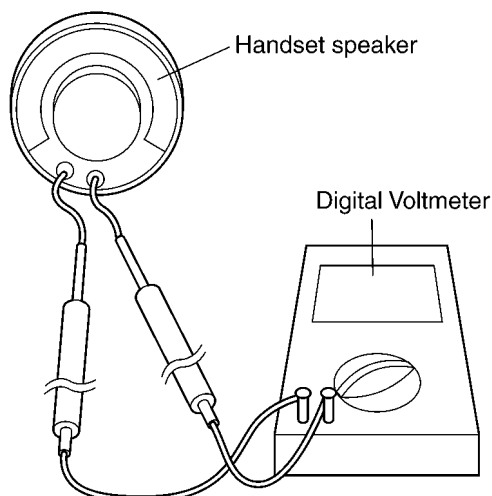
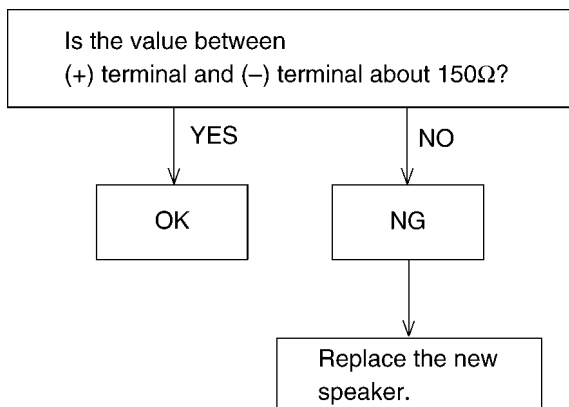

18 FREQUENCY TABLE (MHz)

Channel No	BASE UNIT		HANDSET	
	Transmit Frequency	Receive Frequency	Transmit Frequency	Receive Frequency
1	1897.344	1897.344	1897.344	1897.344
2	1895.616	1895.616	1895.616	1895.616
3	1893.888	1893.888	1893.888	1893.888
4	1892.160	1892.160	1892.160	1892.160
5	1890.432	1890.432	1890.432	1890.432
6	1888.704	1888.704	1888.704	1888.704
7	1886.976	1886.976	1886.976	1886.976
8	1885.248	1885.248	1885.248	1885.248
9	1883.520	1883.520	1883.520	1883.520
10	1881.792	1881.792	1881.792	1881.792

Note:

Channel No. 10: In the Test Mode on Base Unit and Handset.

19 BLOCK DIAGRAM (BASE UNIT)

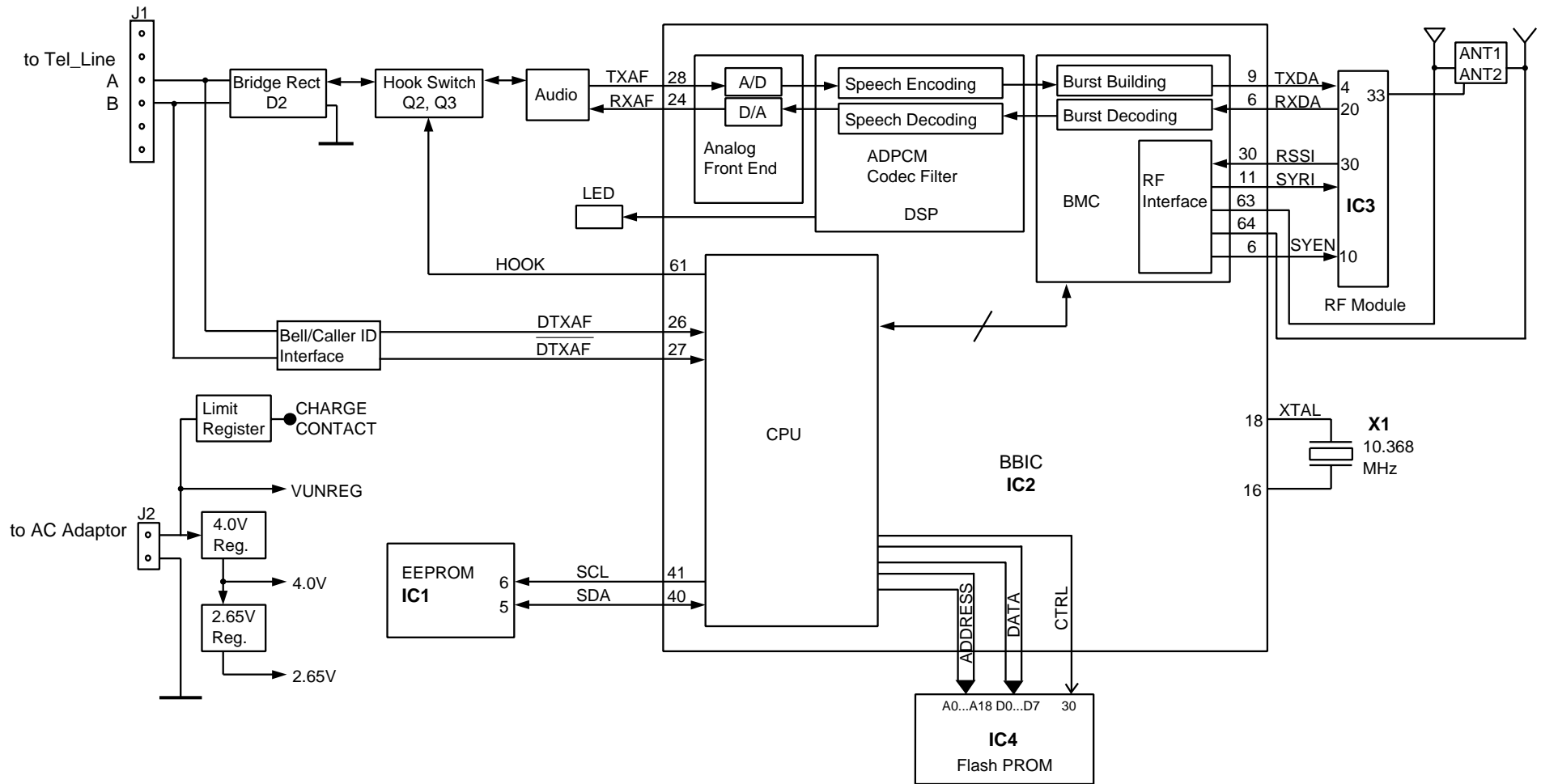

KX-TCD410RUM/RUS&412RUM/RUS BLOCK DIAGRAM (BASE UNIT)

20 CIRCUIT OPERATION (BASE UNIT)

20.1. Outline

Base Unit consists of the following ICs as shown in **BLOCK DIAGRAM (BASE UNIT)** (P.52).

- DECT BBIC (**B**ase **B**and IC): IC2
 - Handling all the audio, signal and data processing needed in a DECT base unit
 - Controlling the DECT specific physical layer and radio section (**B**urst **M**odule **C**ontroller section)
 - ADPCM codec filter for speech encoding and speech decoding (DSP section)
 - Echo-cancellation and Echo-suppression (DSP section)
 - Any tones (tone, sidetone, ringing tone, etc.) generation (DSP section)
 - DTMF receiver (DSP section)
 - Clock Generation for RF Module
 - ADC, DAC, timer, and power control circuitry
 - All interfaces (ex: RF module, EEPROM, LED, Analog Front End, etc.)
- RF Module: IC3
 - PLL Oscillator
 - Detector
 - Compress/Expander
 - First/Second Mixer
 - Amplifier for transmission and reception
- EEPROM: IC1
 - Temporary operating parameters (for RF, etc.)
- Additionally,
 - Power Supply Circuit (+4.0V, +2.65V output)
 - Crystal Circuit (10.368MHz)
 - Charge Circuit
 - Telephone Line Interface Circuit

20.2. Power Supply Circuit

The power is supplied to the DECT BBIC, RF Module, EEPROM, Relay Coil, LED and Charge Contact from AC Adaptor (+6V) as shown in Fig.101. The power supply is as follows;

- DECT BBIC (IC2): J2(+6V) → D4 → Q9 → D5 → Q8 → IC2
- RF Module (IC3): J2(+6V) → D4 → Q9 → L8 → IC3
- EEPROM (IC1): J2(+6V) → D4 → Q9 → D5 → Q8 → IC1
- Flash Memory (IC4): J2(+6V) → D4 → Q9 → D5 → Q8 → IC4
- LED (LED1): J2(+6V) → D4 → Q9 → R68 → LED1
- Charge Contact (TP84): J2(+6V) → D4 → R43, R44 → L4 → TP84

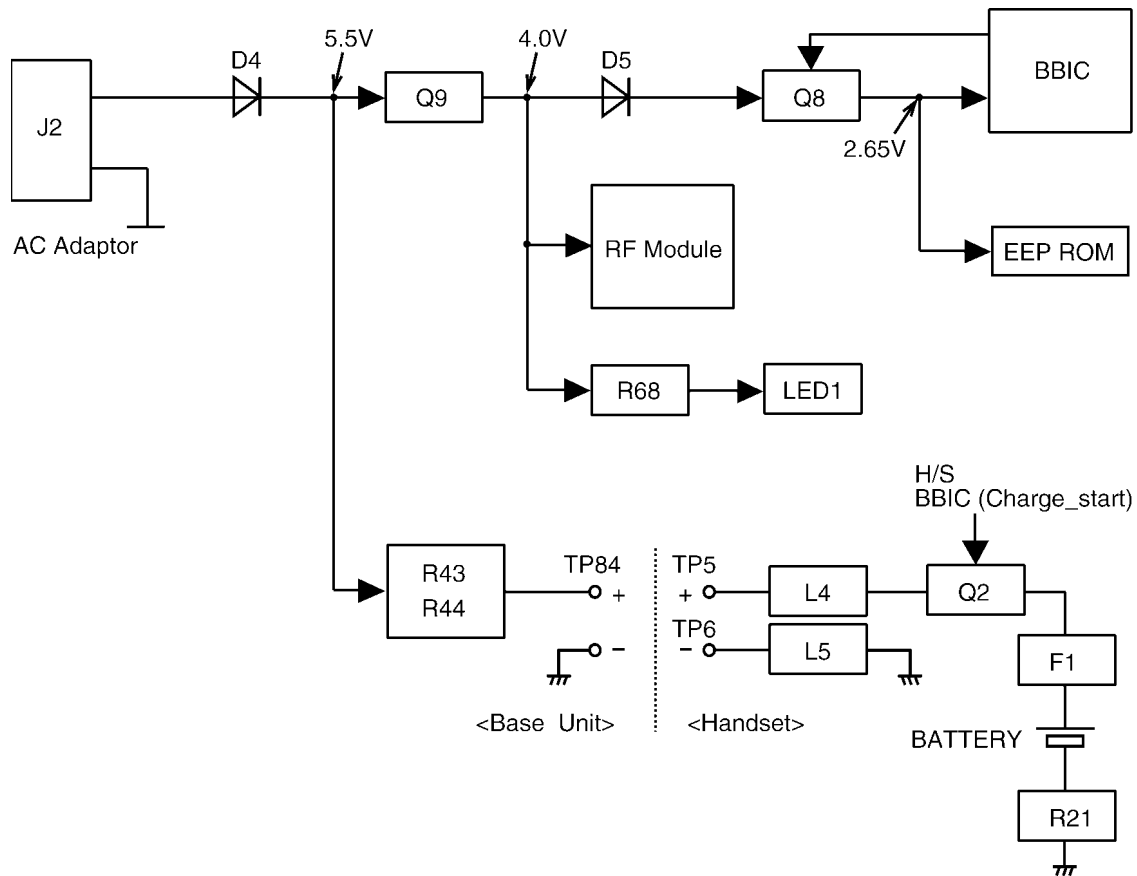

<Fig.101>

20.3. Telephone Line Interface

<Function>

- Bell signal detection
- Clip signal detection
- ON/OFF hook circuit
- Audio circuits

Bell & Clip (: Calling Line Identification Presentation: Caller ID) signal detection:

In the standby mode, Q2 is open to cut the DC loop current and decrease the ring load.

When ring voltage appears at the TP3 (A) and TP40 (B) leads (when the telephone rings), the signal is transferred as follows;

- A → C4 → R2 → R29 → IC2 (DLP) [**BELL & CLIP**]
- B → C3 → R1 → R30 → IC2 (DLP) [**BELL & CLIP**]

ON/OFF hook circuit:

In the standby mode, Q2 is open, and connected as to cut the DC loop current and to cut the voice signal. The unit is consequently in an **off-hook condition**.

When IC2 detects a ring signal or press the TALK Key onto the handset, Q3 turns on and then Q2 turns on, thus providing an **off-hook condition** (active DC current flow through the circuit) and the following signal flow is for the loop current.

- A → R77 → D2 → Q2 → R8 → Q3 → D2 → B [**OFF HOOK**]

20.4. Transmitter/Receiver

Base Unit and Handset mainly consist of RF Module and DECT BBIC.

Base Unit and Handset transmit/receive voice signal and data signal through the antenna on carrier frequency.

Signal Pass:

*Refer to **SIGNAL ROUTE** (P.58).

20.4.1. Transmitter Block

The voice signal input from the TEL LINE interface goes to RF Module (IC3) through DECT BBIC (IC2) as shown in **BLOCK DIAGRAM (BASE UNIT)** (P.52)

The voice signal passes through the analog part of IC2 where it is amplified and converted to a digital audio stream signal. The burst switch controller processes this stream performing encryption and scrambling, adding the various other fields to produce the GAP (**G**eneric **A**ccess **P**rofile) standard DECT frame, assigning to a time slot and channel etc.

In IC3, the carrier frequency is changing, and frequency modulated RF signal is generated and amplified, and radiated from antenna. Handset detects the voice signal or data signal in the circuit same as the following explanation of Receiver Block.

20.4.2. Receiver Block

The signal of 19.2 MHz band (18.81792 MHz ~ 18.97344 MHz) which is input from antenna is input to IC3 as shown in **BLOCK DIAGRAM (BASE UNIT)** (P.52).

In IC3, the signal of 19.2 MHz band is downconverted to 864 kHz signal and demodulated, and goes to IC2 as GAP (**G**eneric **A**ccess **P**rofile) standard DECT frames. It passes through the decoding section burst switch controller where it separates out the frame information and performs de-encryption and de-scrambling as required. It then goes to the DSP section where it is turned back into analog audio. This is amplified by the analog front end, and goes to the TEL LINE Interface.

20.5. Pulse Dialing

During pulse dialing the hookswitch (Q2,Q3) is used to generate the pulses using the HOOK control signal, which is set high during pulses. To force the line impedance low during the "pause" intervals between dialpulses, the PULSE_DIAL signal turns on Q7.

20.6. FLASH PROM

The 4 Mbit (IC4) Flash PROM contains the operational firmware for the microcontroller. It is interfaced to the data/address/control bus using address lines A0 to A18, data lines D0 to D7, and chip select (pin 30), output enable (pin 32), and write (pin 7).

21 BLOCK DIAGRAM (HANDSET)

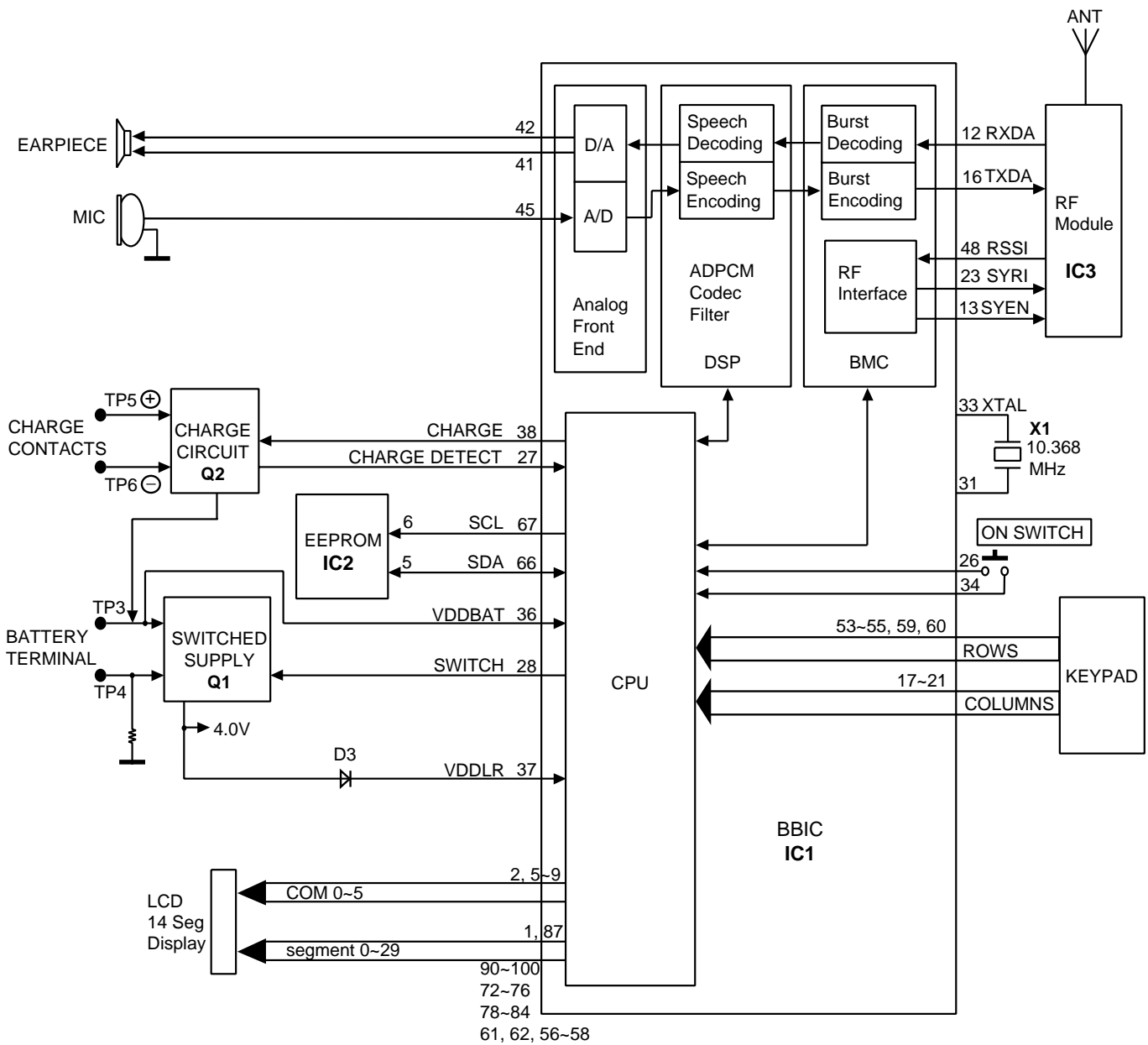

KX-A141RUM/RUS&142RUM/RUS BLOCK DIAGRAM (HANDSET)

22 CIRCUIT OPERATION (HANDSET)

22.1. Outline

Handset consists of the following ICs as shown in **BLOCK DIAGRAM (HANDSET)** (P.56).

- DECT BBIC (**B**ase **B**and IC): IC1
 - All data signals (forming/analyzing ACK or CMD signal)
 - All interfaces (ex: Key, Detector Circuit, Charge, DC/DC Converter, EEPROM, LCD)
- RF Module: IC3
 - PLL Oscillator
 - Detector
 - Compress/Expander
 - Amplifier for transmission and reception

22.2. Power Supply Circuit/Reset Circuit

Circuit Operation:

When power on the Handset, the voltage is as follows;

BATTERY(2.2 V ~ 2.6V: TP3) → TP14(4V) → IC3(6, 27), D3 → IC1(37) → IC1(39, 63) (2.65V)

The Reset signal generates R19, C23 and 2.65V.

22.3. Charge Circuit

Circuit Operation:

- **When charging the handset on the Base Unit, the charge current is as follows;**

DC+(5.5V ~ 6V) → D4 → R43, R44 → CHARGE+(Base) → CHARGE+(Handset) → L4 → Q2 → F1 → BATTERY+ ... Battery ... BATTERY- → R21 → GND → L5 → CHARGE-(Handset) → CHARGE-(Base) → GND → DC-(GND)

- **When charging the handset on the Charger Unit, the charge current is as follows;**

DC+(5.5V ~ 6V) → D1 → R1, R2 → CHARGE+(Charger Unit) → CHARGE+(Handset) → F1 → BATTERY+ ... Battery ... BATTERY- → R21 → GND → CHARGE-(Handset) → CHARGE-(Charger Unit) → GND → DC-(GND)

In this way, the BBIC on Handset detects the fact that the battery is charged.

The charge current is controlled by switching Q2 of Handset.

Refer to Fig.101 in **Power Supply Circuit** (P.54).

22.4. Battery Low/Power Down Detector

Circuit Operation:

"Battery Low" and "Power Down" are detected by BBIC which check the voltage from battery.

The detected voltage is as follows;

- Battery Low

Battery voltage: $V(\text{Batt}) < 2.3\text{V}$

The BBIC detects this level and " starts flashing and "battery alarm" starts ringing.

- Power Down

Battery voltage: $V(\text{Batt}) < 2.2\text{V}$

The BBIC detects this level and power down.

23 CIRCUIT OPERATION (CHARGER UNIT)

23.1. Power Supply Circuit

The power supply is as shown.

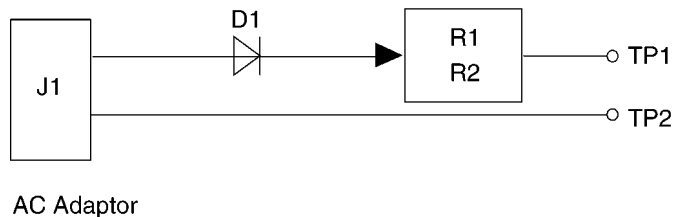

24 SIGNAL ROUTE

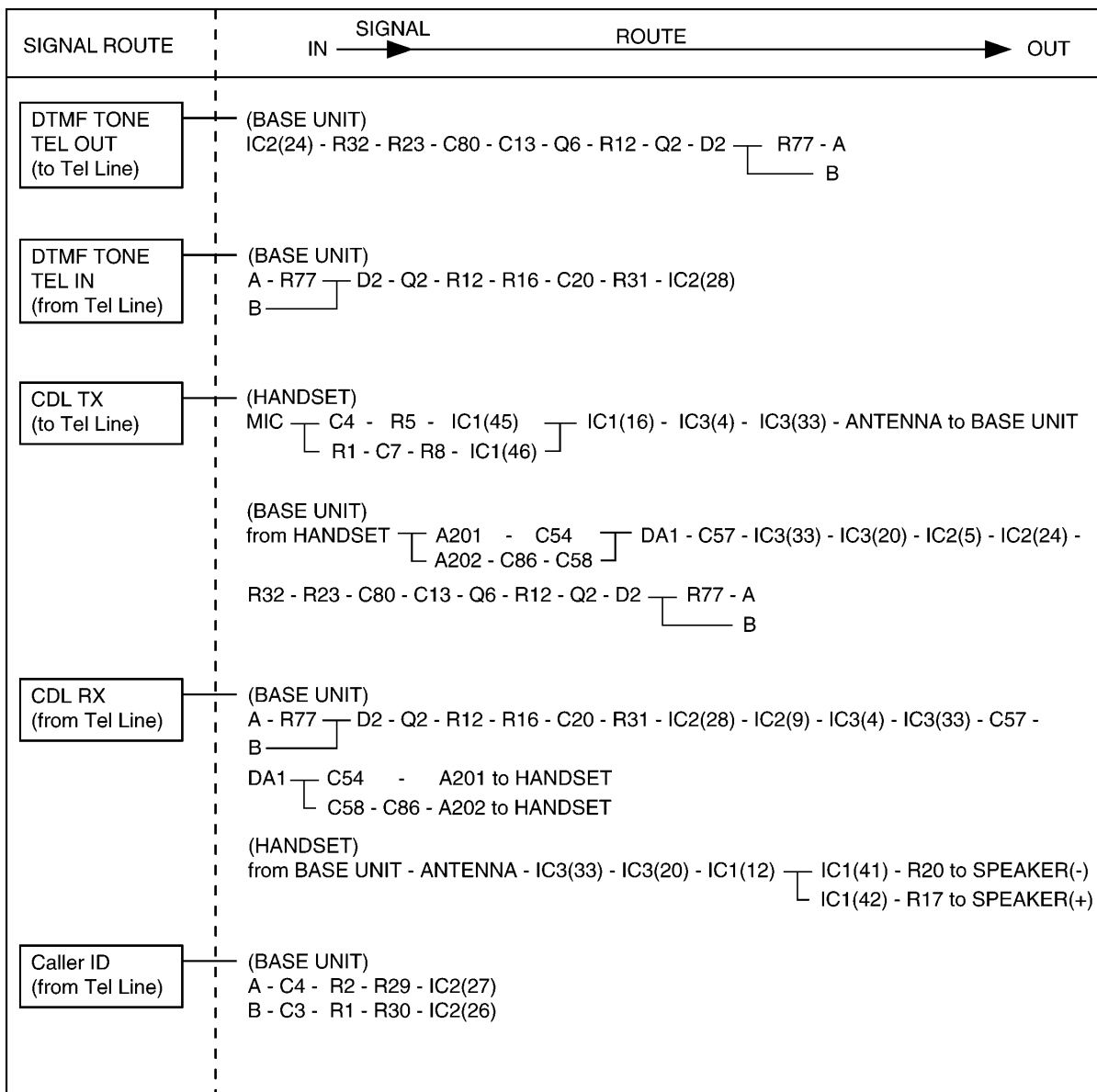

25 CPU DATA (BASE UNIT)

25.1. IC2 (BBIC)

Pin	Description	I/O	Hi	Hi-z	Low	Remarks
1	VDD	-	-	-	-	-
2	VSS	-	-	-	-	-
3	Data Bus	D.I/O	-	-	-	for Flash Memory
4	PA_Driver_Amp	D.O	PA-ON	-	PA-OFF	-
5	Data Bus	D.I/O	-	-	-	for Flash Memory
6	TX/RX SW	D.O	TX	-	RX	-
7	Data Bus	D.I/O	-	-	-	for Flash Memory
8	RX Data	D.I	Active	-	Active	-
9	Data Bus	D.I/O	-	-	-	for Flash Memory
10	PLL Strobe	D.O	Normal	-	Latch	-
11	Data Bus	D.I/O	-	-	-	for Flash Memory
12	PLL Data	D.O	Active	-	Active	-
13	PLL Clk	D.O	Active	-	Active	-
14	Address Bus	D.O	-	-	-	for Flash Memory
15	TX Data	A.O	Active	-	Active	-
16	Address Bus	D.O	-	-	-	for Flash Memory
17	(NO USE)	D.O	-	-	-	-
18	Address Bus	D.O	-	-	-	for Flash Memory
19	Address Bus	D.O	-	-	-	for Flash Memory
20	RF System Clk	D.O	Active	-	Active	-
21	VDD	-	-	-	-	-
22	VSS	-	-	-	-	-
23	RESET	A.I	Normal	-	Reset	-
24	VDDPM	A.O	-	-	-	-
25	VSSO	D.I	-	-	-	-
26	(NO USE)	-	-	-	-	-
27	LOAD	A.I	-	-	-	-
28	XTAL	A.I	-	-	-	10.368MHz
29	NC	-	-	-	-	-
30	VDDLRL	A.I	-	-	-	-
31	LRB	D.I	-	-	-	-
32	NC	-	-	-	-	-
33	VDDA	-	-	-	-	-
34	VSSA	-	-	-	-	-
35	(NO USE)	-	-	-	-	-
36	Audio Out N	A.O	-	-	-	-
37	Audio Out P	A.O	-	-	-	-
38	(NO USE)	-	-	-	-	-
39	Bandgap Ref	A.I	-	-	-	-
40	Differential Line P	A.I	-	-	-	for Bell Clip
41	(NO USE)	-	-	-	-	-
42	Differential Line N	A.I	-	-	-	for Bell Clip
43	Audio In N	A.I	-	-	-	-
44	(NO USE)	-	-	-	-	-
45	ADC Ref	A.I	-	-	-	-
46	RSSI	A.I	-	-	-	-
47	(NO USE)	-	-	-	-	-
48	AD2	A.I	-	-	-	for Polarity
49	AD3	A.I	-	-	-	for Polarity
50	(NO USE)	-	-	-	-	-
51	PX.0	D.I	(I_PU)	-	-	-
52	Address Bus	D.O	-	-	-	for Flash Memory
53	(NO USE)	D.I	(I_PU)	-	-	-
54	Address Bus	D.O	-	-	-	for Flash Memory
55	(NO USE)	D.I	(I_PU)	-	-	-
56	Address Bus	D.O	-	-	-	for Flash Memory
57	(NO USE)	D.I	(I_PU)	-	-	-
58	Address Bus	D.O	-	-	-	for Flash Memory
59	VDD	-	-	-	-	-
60	VSS	-	-	-	-	-
61	Address Bus	D.O	-	-	-	for Flash Memory
62	Address Bus	D.O	-	-	-	for Flash Memory

Pin	Description	I/O	Hi	Hi-z	Low	Remarks
63	Serial Data(I2C)	D.I/O	Data	-	Data	-
64	Serial Clk(I2C)	D.I/O	Active	-	Active	-
65	Address Bus	D.O	-	-	-	for Flash Memory
66	Address Bus	D.O	-	-	-	for Flash Memory
67	MODE	D.I	-	-	(Fixed)	-
68	WR	D.O	-	-	Write IC4	for Flash Memory
69	R2/P1.7	D.O	-	-	(Fixed)	-
70	Address Bus	D.O	-	-	-	for Flash Memory
71	Bell/Paging LED	D.O	LED ON	-	LED OFF	-
72	VBACK	A.I	-	-	-	-
73	VSS	-	-	-	-	-
74	Address Bus	D.O	-	-	-	for Flash Memory
75	Address Bus	D.O	-	-	-	for Flash Memory
76	DSPIN/P1.0	D.I	-	-	(Fixed)	-
77	Address Bus	D.O	-	-	-	for Flash Memory
78	DSPOUT/P1.1	D.I	(Fixed)	-	-	-
79	Address Bus	D.O	-	-	-	for Flash Memory
80	DSPCLK/P1.2	D.I	-	-	(Fixed)	-
81	Address Bus	D.O	-	-	-	for Flash Memory
82	DSPFRM/P1.3	D.O	-	-	(Fixed)	-
83	OE	D.O	-	-	Read IC4	for Flash Memory
84	VSS	-	-	-	-	-
85	VDD	-	-	-	-	-
86	Address Bus	D.O	-	-	-	for Flash Memory
87	Key IN	D.I	No Key	-	Key	-
88	(NO USE)	D.I	-	-	(I PD)	-
89	CE	D.O	-	-	IC4 Active	for Flash Memory
90	(NO USE)	D.O	-	-	-	-
91	(NO USE)	D.O	-	-	-	-
92	Data Bus	D.I/O	-	-	-	for Flash Memory
93	(NO USE)	D.I	-	-	(I PD)	-
94	(NO USE)	D.I	-	-	(I PD)	-
95	HOOK CTRL	D.O	Make	-	Break	-
96	Data Bus	D.I/O	-	-	-	for Flash Memory
97	(NO USE)	D.O	-	-	-	-
98	Data Bus	D.I/O	-	-	-	for Flash Memory
99	ANT1	D.O	ANT1 ON	-	ANT1 OFF	-
100	ANT2	D.O	ANT2 ON	-	ANT2 OFF	-

Note:

I_PU; Internal Pull-Up, I_PD; Internal Pull-Down

26 CPU DATA (HANDSET)

26.1. IC1 (BBIC)

Pin	Description	I/O	Hi	Hi-z	Remarks
1	LCD_SEGMENT	D.O	Active	-	-
2	LCD_COMMON	D.O	Active	-	-
3	VDD	-	-	-	-
4	VSS	-	-	-	-
5	LCD_COMMON	D.O	Active	-	-
6	LCD_COMMON	D.O	Active	-	-
7	LCD_COMMON	D.O	Active	-	-
8	LCD_COMMON	D.O	Active	-	-
9	LCD_COMMON	D.O	Active	-	-
10	PA_SW	D.O	PA ON	-	-
11	T/R SW	D.O	Transmit	-	-
12	RX_DATA	D.I	Active	-	-
13	SYEN	D.O	Active	-	-
14	SYDA	D.O	Active	-	-
15	SYCL	D.O	Active	-	-
16	TX_DATA	A.O	Active	-	-
17	KEY_IN	D.I	No Key	-	-
18	KEY_IN	D.I	No Key	-	-
19	KEY_IN	D.I	No Key	-	-
20	KEY_IN	D.I	No Key	-	-
21	KEY_IN	D.I	No Key	-	-
22	(NO USE)	D.O	-	-	-
23	Reference clock	D.O	Active	-	-
24	VDD	-	-	-	-
25	VSS	-	-	-	-
26	POWER_SW	A.I	No Key	-	-
27	CHARGE_DET	A.I	Charge	-	-
28	DCDCDRV	D.O	Active	-	-
29	DCDCMR	A.I	-	-	-
30	RESET	A.I	Normal	-	-
31	VSSO	-	-	-	-
32	LOAD	A.I	-	-	-
33	XTAL	A.I	-	-	-
34	VDDPM	A.O	-	-	-
35	VDDLO	A.O	-	-	-
36	VddbAT	A.I	-	-	-
37	VDDLr	-	-	-	-
38	CHARGE_START	A.O	-	-	for charge
39	VDDA	-	-	-	-
40	VSSA	-	-	-	-
41	LSRN	A.O	-	-	-
42	LSRP	A.O	-	-	-
43	BANDGAP_REF	A.O	-	-	-
44	MICS	A.O	-	-	-
45	MICP	A.I	-	-	-
46	MICN	A.I	-	-	-
47	Reference Voltage	A.O	-	-	-
48	RSSI	A.I	-	-	-
49	P0.4	D.I	-	-	-
50	AD4N	A.I	-	-	-
51	AD4P	A.I	-	-	-
52	(NO USE)	D.I	-	-	-
53	KEY_STRB	D.O	Active	-	-
54	KEY_STRB	D.O	Active	-	-
55	KEY_STRB	D.O	Active	-	-
56	LCD_SEGMENT	D.O	Active	-	-
57	LCD_SEGMENT	D.O	Active	-	-
58	LCD_SEGMENT	D.O	Active	-	-
59	KEY_STRB	D.O	Active	-	-
60	KEY_STRB	D.O	Active	-	-
61	LCD_SEGMENT	D.O	Active	-	-
62	LCD_SEGMENT	D.O	Active	-	-

Pin	Description	I/O	Hi	Hi-z	Remarks
63	VDD	-	-	-	-
64	VSS	-	-	-	-
65	VDD for EEPROM	D.O	-	-	-
66	I2DAT	D.I/O	Active	-	-
67	I2CLK	D.I/O	Active	-	-
68	MODE	D.I	-	-	-
69	R2	D.I	-	-	-
70	(NO USE)	D.O	-	-	-
71	VBACK/P0.7	D.I	-	-	-
72	LCD_SEGMENT	D.O	Active	-	-
73	LCD_SEGMENT	D.O	Active	-	-
74	LCD_SEGMENT	D.O	Active	-	-
75	LCD_SEGMENT	D.O	Active	-	-
76	LCD_SEGMENT	D.O	Active	-	-
77	VDDLI	-	-	-	-
78	LCD_SEGMENT	D.O	Active	-	-
79	LCD_SEGMENT	D.O	Active	-	-
80	LCD_SEGMENT	D.O	Active	-	-
81	LCD_SEGMENT	D.O	Active	-	-
82	LCD_SEGMENT	D.O	Active	-	-
83	LCD_SEGMENT	D.O	Active	-	-
84	LCD_SEGMENT	D.O	Active	-	-
85	VSS	-	-	-	-
86	VDD	-	-	-	-
87	LCD_SEGMENT	D.O	Active	-	-
88	(NO USE)	D.O	-	-	-
89	Power Select	D.O	Low Power	-	-
90	LCD_SEGMENT	D.O	Active	-	-
91	LCD_SEGMENT	D.O	Active	-	-
92	LCD_SEGMENT	D.O	Active	-	-
93	LCD_SEGMENT	D.O	Active	-	-
94	LCD_SEGMENT	D.O	Active	-	-
95	LCD_SEGMENT	D.O	Active	-	-
96	LCD_SEGMENT	D.O	Active	-	-
97	LCD_SEGMENT	D.O	Active	-	-
98	LCD_SEGMENT	D.O	Active	-	-
99	LCD_SEGMENT	D.O	Active	-	-
100	LCD_SEGMENT	D.O	Active	-	-

27 EEPROM LAYOUT (BASE UNIT)

27.1. Scope

The purpose of this section is to describe the layout of the EEPROM (IC1) for the KX-TC410 Base Unit.

The EEPROM contains hardware, software, and user specific parameters. Some parameters are set during production of the base e.g. crystal frequency adjustment at address 0000 and 0001, some are set by the user configuration e.g. ringer volume at address 0220, and some are set during normal use of the phone e.g. meter pulse billing at address 0140..015F.

27.2. Introduction

The base unit uses a 32K bit serial EEPROM (IC1) for storing volatile parameters. All parameters are set up before the base leaves the factory. Some of these are vital for the operation of the hardware so a set of default parameters is programmed before the actual hardware fine-tuning can be initiated. This document lists all default settings with a short description.

In the tables below values in a range that are similar are not repeated; i.e. Address 00 to 01 contains the value 00 simply means that the value 00 is repeated in all addresses in the range. All values in this document are in hexadecimal notation.

Type	Name	Description
D	default	The EEPROM location is preset to the Default value by the eeprom default loader.
A	adjust	The EEPROM location is set during the production test and should not be overwritten. The value is set by the eeprom default loader only if the location contains all 1's (byte: 0xFF, word FFFFh), i. e. it has never been set.
-		EEPROM location which is not set at all.
d	default	Same as D but best-guess value and/or not verified.

Country Setting	x	Description
		Default - no specific country setting, so revert to default value

27.3. EEPROM Layout

27.3.1. General Setup

Address	Default	Name	Country Setting	Type	Description
0000-01	00 E0	EepromOscillator	x	A	Frequency adjustment
0002	20	ModulationDeviation	x	A	Modulation adjustment
0020	-	RFPI (ID for Base Unit)	x	A	RFPI
0025	00 00	AC (Base PIN code)	x	D	AC code
0028	00	TBR22Test	x	-	TBR22 test
0030-0034	FF .. FF	IPUI_1 (ID for H/S 1)	x	D	Ipui for handset 1. If set to FF .. FF (5bytes) the handset is not enrolled.
0035-0039	FF .. FF	IPUI_2 (ID for H/S 2)	x	D	Ipui for handset 2. If set to FF .. FF (5bytes) the handset is not enrolled.
003A-003E	FF .. FF	IPUI_3 (ID for H/S 3)	x	D	Ipui for handset 3. If set to FF .. FF (5bytes) the handset is not enrolled.
003F-0043	FF .. FF	IPUI_4 (ID for H/S 4)	x	D	Ipui for handset 4. If set to FF .. FF (5bytes) the handset is not enrolled.
0044-0048	FF .. FF	IPUI_5 (ID for H/S 5)	x	D	Ipui for handset 5. If set to FF .. FF (5bytes) the handset is not enrolled.
0049-004D	FF .. FF	IPUI_6 (ID for H/S 6)	x	D	Ipui for handset 6. If set to FF .. FF (5bytes) the handset is not enrolled.
004E-008F	-	Reserved	x	-	Protocol data
0090-009F	-	UAK_1	x	-	UAK for handset 1 (for factory use)
00A0-00AF	-	UAK_2	x	-	UAK for handset 2 (for factory use)
00B0-00BF	-	UAK_3	x	-	UAK for handset 3 (for factory use)
00C0-00CF	-	UAK_4	x	-	UAK for handset 4 (for factory use)
00D0-00DF	-	UAK_5	x	-	UAK for handset 5 (for factory use)
00E0-00EF	-	UAK_6	x	-	UAK for handset 6 (for factory use)

27.3.2. Switch Control

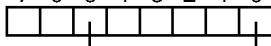
Address	Default	Name	Country Setting	Type	Description
09F1	00	HsRegInfo.RegFlags	x	D	Handset registration info - registration ON/OFF bit 7 6 5 4 3 2 1 0  1=reg, 0=no reg

Address	Default	Name	Country Setting	Type	Description
09F2	00	HsRegInfo.EmcFlags	x	D	Handset registration info - EMC flags Bit 6..7: not used 0..5: handset 1..6 info, 1=known, 0=unknown
09F3	21	RingMode	x	D	Ring mode. Modes used in KAMMA4 are 20h and 21h. Bit 7..5: Mode (001=group) 4 : Not used 3..0: Id (001= id of first group)

27.3.3. Flash Time setting

Address	Default	Name	Country Setting	Type	Description
0F0B	08	CalibBreakTime[0]	0A	D	Calibrated loop-break time for short break Unit: 10 ms, defaultst to 80 ms
0F0C	14	CalibBreakTime[1]	46	D	Calibrated loop-break time for short break Unit: 10 ms, defaultst to 200 ms
0F0D	46	CalibBreakTime[2]	14	D	Calibrated loop-break time for short break Unit: 10 ms, defaultst to 700 ms

27.3.4. Clip (Caller ID) configuration

Address	Default	Name	Country Setting	Type	Description
0F1C	70	Detect	74	D	CLIP detect configuration Bit 0-2: Mode: 0: Learn mode, 1: DTMF only, 2: FSK only, 3: Generic mode, 4: Russian CLIP only 3: Unused4 4: Onhook: 1=enable 0=disable 5: Offhook: 1=enable 0=disable 6: Msgwaiting: 1=enable 0=disable 7: Unused7
0F37..38	3D 01	Parse.Configuration	3D 00	D	Clip parse set configuration Bit 0: Etsi: 1=enable 0=disable 1: ForwardNumber: 1=enable 0=disable 2: Danish: 1=enable 0=disable 3: Dutch: 1=enable 0=disable 4: Canadian: 1=enable 0=disable 5: Swedish: 1=enable 0=disable 6: UserDefined: 1=enable 0=disable 7: KPN vmwi: 1=enable 0=disable 8: ProtocolPriority: If 2 mutually exclusive parameters occurs, the 1st in the protocol message has priority. 1=enable 0=disable 9: UseCallType: Verify the Call Type parameter, if available, when receiving Call Back CLIP at busy subscriber. 1=enable 0=disable 10: AddTop0IfNo0 Automatic addition of 0 if top of Caller ID is not 0. 1=enable 0=disable 11: DtmfDigitsOnly Parse DTMF clip without start and/or stop code. 1=enable 0=disable 12..15: Reserved12..Reserved15
0F3D	00	Rcid.Mode	x	D	RCID mode Bit 0: answer-mode, 1=auto-answer, 0=manual answer 1..4: 0 5: detect length, 1=enable(development only), 0=disable 6: add category, 1=enable(development only), 0=disable 7: 0

Address	Default	Name	Country Setting	Type	Description
0F3E	70	Rcid.Options	x	D	RCID mode Bit 1..3: 0 4: pre-detect before first RCID-request, 1=enable, 0=disable 5: emulate ring-back tone, 1=enable, 0=disable 6: detect ring-timing, 1=enable, 0=disable 7: 0
0F3F	73	Rcid.PacketLen_RetryCnt	x	D	RCID mode packet length and request retry count Bit 7..4: Packet length including start/begin+category (default 9) 3..0: Request-Retry Count (default 3)
0F40	01	Rcid.RingCntToStart	x	D	RCID, number of ring's before auto-answering call 0: on first ring-volt-off 1..9: on 1-9 ring pattern-off
0F41	04	Rcid.LineSeizureT0	x	D	RCID line-seizure delay Unit: 50ms, defaults to 200ms.
0F42	00	Rcid.ReqDelayT1	x	D	RCID-request delay parameter T1 Delay from line-seizure to 1. Req-tone: T0+T1 (200ms) Delay between two req-tones if no data: T1+T3max (600ms) Dealy between data and next req-tone: T1+T7T8 (150ms) Unit: 1ms, defaults to 0ms
0F43	0E	Rcid.ReqWidthT2	x	D	RCID-request width (T2) Unit: 10ms, defaults to 140ms
0F44	04	Rcid.ReqTimeoutT3Max	x	D	RCID-request to "first RCID data" timeout (T3Max) Unit: 50ms, defaults to 600ms
0F45	04	Rcid.DataTimeoutT7T8Max	02	D	RCID next-digit timeout (T7+T8)max Unit: 50ms, defaults to 150ms
0F46	02	Rcid.SimRingCnt	06	D	RCID simulated-ring count
0F47	38	Rcid.SimRingOnOffTime	x	D	RCID simulated-ring timing Bit 0..3: ring-on time 4..7: ring-off time Unit: 500ms, defaults to 1.5s ring-on time, 4s ring-off time
0F48	01	Rcid.MaxErrCnt	x	D	RCID, max error-count during parsing

27.3.5. BsUiTask settings

Address	Default	Name	Country Setting	Type	Description
0F4B	01	Config1	13	D	BsUiTask configuration (MSB) Bits 1= enable 0=disable 0: AmPmClockSettingEnabled, enabled 1: ClipDetectionSettingEnabled, disabled 2: AkzMenuEnabled, disabled 3: HakzMenuEnabled, disabled 4: RussianClipSttingEnabled, disabled 5: SmscSendNumberSettingEnabled, disabled 6: SMSPabxSupportSettingEnabled, disabled 7: Unused
0F4C	F7	Config2	D7	D	BsUiTask configuration (LSB) Bits 1= enable 0=disable 0: FlashTime1Enabled, enabled 1: FlashTime2Enabled, enabled 2: FlashTime3Enabled, enabled 3: KeyClicksEnable, disabled 4: ARSCarrierMenuEnabled, enabled 5: ARSIntDeletionMenuEnabled, enabled 6: ARSMultipleCarrierMenuEnabled, enabled 7: ARSMultipleAreaCodeMenuEnabled, enabled
0F4E	0F	Config2	FF	D	BsUiTask configuration 2 Bits 1=enable 0=disable 0: RingerModeMenuEnabled, enabled 1: CallRestrictionMenuEnabled, enabled 2: CancelHandsetMenuEnabled, enabled 3: BaseToneMenusEnabled, enabled 4-7: Unused

28 EEPROM LAYOUT (HANDSET)

28.1. Scope

The purpose of this section is to describe "layout of the EEPROM (IC2) KX-A141 Handset".

The EEPROM contains hardware, software, and user specific parameters. Some parameters are set during production of the handset e.g. crystal oscillator adjustment at 0000..01, some are set by the user when configuring the handset e.g. ringer volume at 0F38, and some during normal use of the phone e.g. redial memory at 0311..0392.

28.2. Introduction

The handset uses a 32k bit serial EEPROM (IC2) for storing volatile parameters. All parameters are set up before the handset the factory. Some of these are vital for the operation of the hardware so a set of default parameters is programmed before the actual hardware fine-tuning can be initiated. This document lists all default settings with a short description.

This document lists all default parameters with a short description.

In the tables below values in a range that are similar are not repeated; i.e. Address 00 to 01 contains the value 00 simply means that the value 00 is repeated in all addresses in the range.

Type	Name	Description
D	default	The EEPROM location is preset to the Default value by the eeprom default loader.
A	adjust	The EEPROM location is set during the production test and should not be overwritten. The value is set by the eeprom default loader only if the location contains 0xFF, i. e. it has never been set.
-		EEPROM location which is not set at all.

28.3. EEPROM contents

28.3.1. General Setup

Address	Default	Name	Type	Description
0000-0001	00	EepromOscillator	A	Frequency adjustment
0002	20	ModulationDeviation	A	Mudulation adjustment
0030-0034	00	IPEI (ID for Handset)	A	IPEI
0036-003A	FF	PARK_1 (ID for Base 1)	-	PARK for registration 1
003B-003F	FF	PARK_2 (ID for Base 2)	-	PARK for registration 2
0040-0044	FF	PARK_3 (ID for Base 3)	-	PARK for registration 3
0045-0049	FF	PARK_4 (ID for Base 4)	-	PARK for registration 4
004A-004D	FF	PLI_1-PLI_4	D	Pli for registration 1-4. If set to FF the registration is deleted.

28.3.2. Signal detection (for factory use only)

Address	Default	Name	Country Setting	Type	Description
0100-0104	-	RFPI_1 (Base 1)	-	-	RFPI for registration 1
0105	-	SerClass_1	-	-	Service class for registration 1
0106	-	LAL_1	-	-	Location area level for registration 1
0107	-	IPUI_LEN_1	-	-	IPUI length for registration 1
0108-0114	-	IPUI_1	-	-	IPUI for registration 1
0115	-	ZAP_1	-	-	ZAP for registration 1
0116	-	STATUS_1	-	-	Status for registration 1
0117-126	-	UAK_1	-	-	UAK for registration 1
0130-134	-	RFPI_2 (Base 2)	-	-	RFPI for registration 2
0135	-	SerClass_2	-	-	Service class for registration 2
0136	-	LAL_2	-	-	Location area level for registration 2
0137	-	IPUI_LEN_2	-	-	IPUI length for registration 2
0138-0144	-	IPUI_2	-	-	IPUI for registration 2
0145	-	ZAP_2	-	-	ZAP for registration 2
0146	-	STATUS_2	-	-	Status for registration 2
0147-0156	-	UAK_2	-	-	UAK for registration 2
0160-0164	-	RFPI_3 (Base 3)	-	-	RFPI for registration 3
0165	-	SerClass_3	-	-	Service class for registration 3
0166	-	LAL_3	-	-	Location area level for registration 3
0167	-	IPUI_LEN_3	-	-	IPUI length for registration 3
0168-0174	-	IPUI_3	-	-	IPUI for registration 3
0175	-	ZAP_3	-	-	ZAP for registration 3

Address	Default	Name	Country Setting	Type	Description
0176		STATUS_3	-	-	status for registration 3
0177-0186	-	UAK_3	-	-	UAK for registration 3
0190-0194	-	RFPI_4 (Base 4)	-	-	RFPI for registration 4
0195	-	SerClass_4	-	-	Service class for registration 4
0196	-	LAL_4	-	-	Location area level for registration 4
0197	-	IPUI_LEN_4	-	-	IPUI length for registration 4
0198-01A4	-	IPUI_4	-	-	IPUI for registration 4
01A5	-	ZAP_4	-	-	ZAP for registration 4
01A6	-	STATUS_4	-	-	UAK for registration 4
01A7-01B6	-	UAK_4	-	-	UAK for registration 4
0450-0451	0000	HSPinCode	x	D	4 BCD Digits
0462	00	Language	x	D	00 = English 01 = Spanish 02 = French 03 = Italian 04 = Dutch 05 = Turkish 06 = Hungarian 07 = Portuguese 08 = Polish 09 = Command 0A = German
0467	00	FactoryLanguageSetting	x	D	Factory setting for language: 00 = English 01 = Spanish 02 = French 03 = Italian 04 = Dutch 05 = Turkish 06 = Hungarian 07 = Portuguese 08 = Polish 09 = Command 0A = German
0469	07	MaxDigitsToMatch	x	D	Valid values: 01 - FF Digits above this value will not be evaluated, when matching.
046A	05	MinDigitsToMatch	x	D	Valid values: 01 - FF (-Must be lower than MaxDigitsToMatch). -If all digits of one of the numbers match completely, -with at least this number of digits, we have a match. (-Or if they match completely with less digits, we also have match.)

28.3.3. Battery Parameters

Address	Default	Name	Type	Description
0F04	9A	LowVoltage	A	Voltage on which to start battery low-indication. The voltage has to be measured under this value for 8 seconds before the handset start signaling low battery. LowVoltage[EEPROM]=[ADC-steps]=LowVoltage[mV] (14.35[mV/step])

28.3.4. Default Audio-Parameters

Address	Default	Name	Country Setting	Type	Description
0F36	46	GR-offset for volumestep 1	x	D	Bit7: AOG Bit6: AOG2 Bit5, bit0: Gain-receive (values ranging from 0x00 to 0x30, each step representing 1 dB)
0F37	5F	GR-offset for volumestep 2	x	A	Bit7: AOG Bit6: AOG2 Bit5, bit0: Gain-receive (values ranging from 0x00 to 0x30, each step representing 1 dB)
0F38	46	GR-offset for volumestep 3	00	D	Bit7: AOG Bit6: AOG2 Bit5, bit0: Gain-receive offset to volumestep 2 (values ranging from 0x00 to 0x30, each step representing 1 dB)
0F3F	02	EEVoiceVolume	x	D	Volume of the earpiece

28.3.5. VolumeSetting Second Block

Address	Default	Name	Country Setting	Type	Description
0F53	FF	Menu Config	x	D	bit 0 - Registration menu on/off 1/0 bit 1 - Select base menu on/off 1/0 bit 2 - Internal ringer menu on/off 1/0 bit 3 - Page ringer menu on/off 1/0 bit 4 - Standby mode menu on/off 1/0 bit 5 - Battery select menu on/off 1/0 bit 6 - Call waiting menu on/off 1/0 bit 7 - Clip list on/off 1/0
0F54	01	RecVolStoreEnabled	x	D	00: Receiver volume will be reset to default value when hooking on. 01: Receiver volume will be stored in eeprom when set in conversation.

29 HOW TO REPLACE FLAT PACKAGE IC

29.1. Preparation

- PbF (: Pb free) Solder
- Soldering Iron

Tip Temperature of 700°F ± 20°F (370°C ± 10°C)

Note: We recommend a 30 to 40 Watt soldering iron. An expert may be able to use a 60 to 80 Watt iron where someone with less experience could overheat and damage the PCB foil.

- Flux

Recommended Flux: Specific Gravity → 0.82.

Type → RMA (lower residue, non-cleaning type)

Note: See **ABOUT LEAD FREE SOLDER (PbF: Pb free)** (P.4).

29.2. Procedure

1. Tack the flat pack IC to the PCB by temporarily soldering two diagonally opposite pins in the correct positions on the PCB.

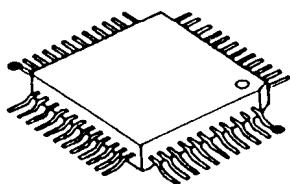

● - - - - - Temporary soldering point.

Be certain each pin is located over the correct pad on the PCB.

2. Apply flux to all of the pins on the IC.

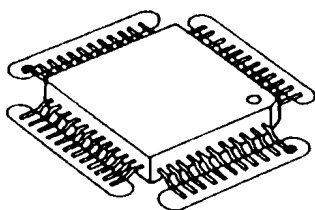

○ - - - - - Flux

3. Being careful to not unsolder the tack points, slide the soldering iron along the tips of the pins while feeding enough solder to the tip so that it flows under the pins as they are heated.

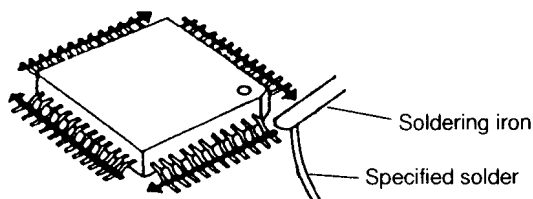

29.3. Modification Procedure of Bridge

1. Add a small amount of solder to the bridged pins.
2. With a hot iron, use a sweeping motion along the flat part of the pin to draw the solder from between the adjacent pads.

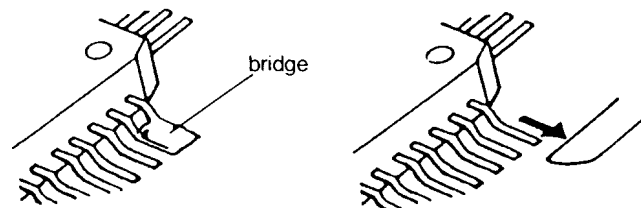

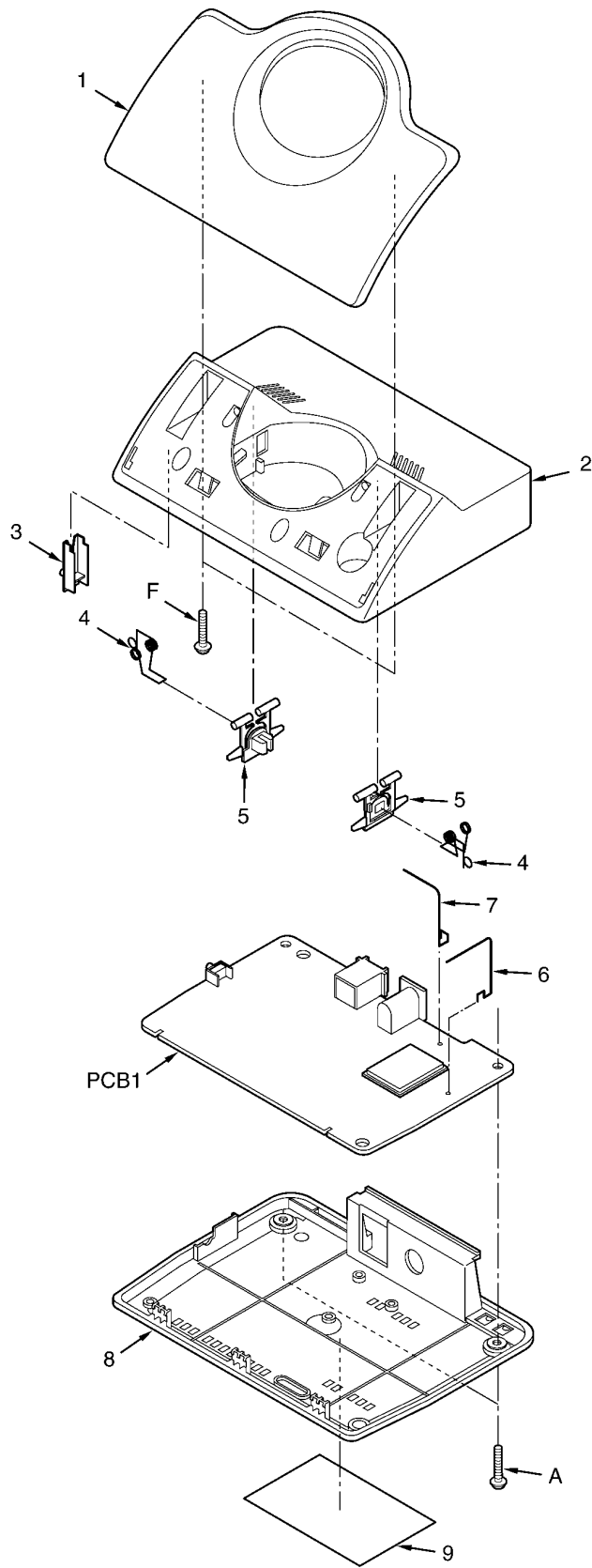

30 CABINET AND ELECTRICAL PARTS LOCATION (BASE UNIT)

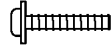
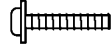

Ref.No.	Part No.	Figure
A	XTW26+12P	 φ2.6 × 12mm
F	XTW26+12P	 φ2.6 × 12mm

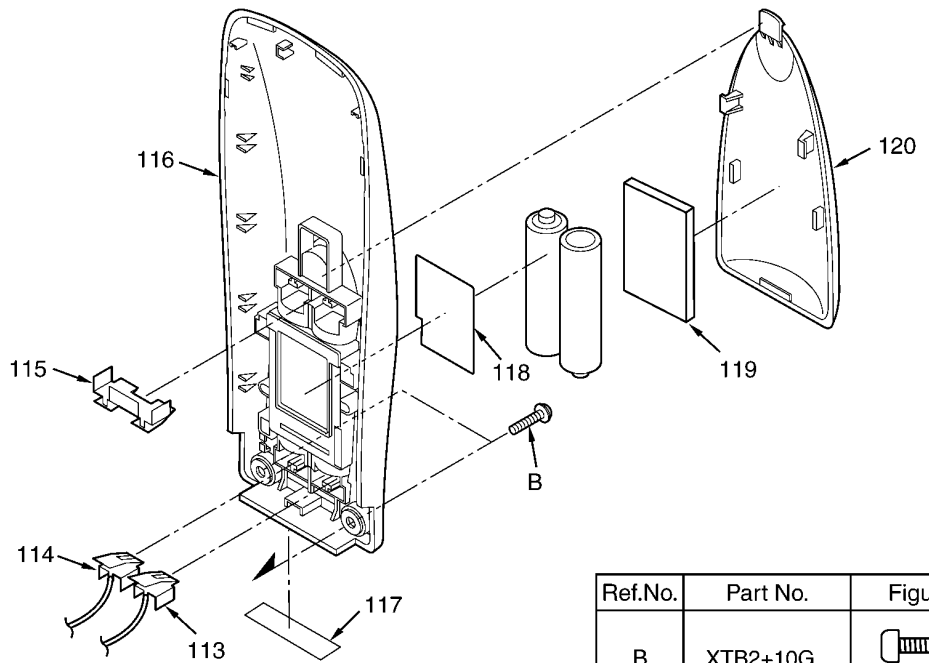
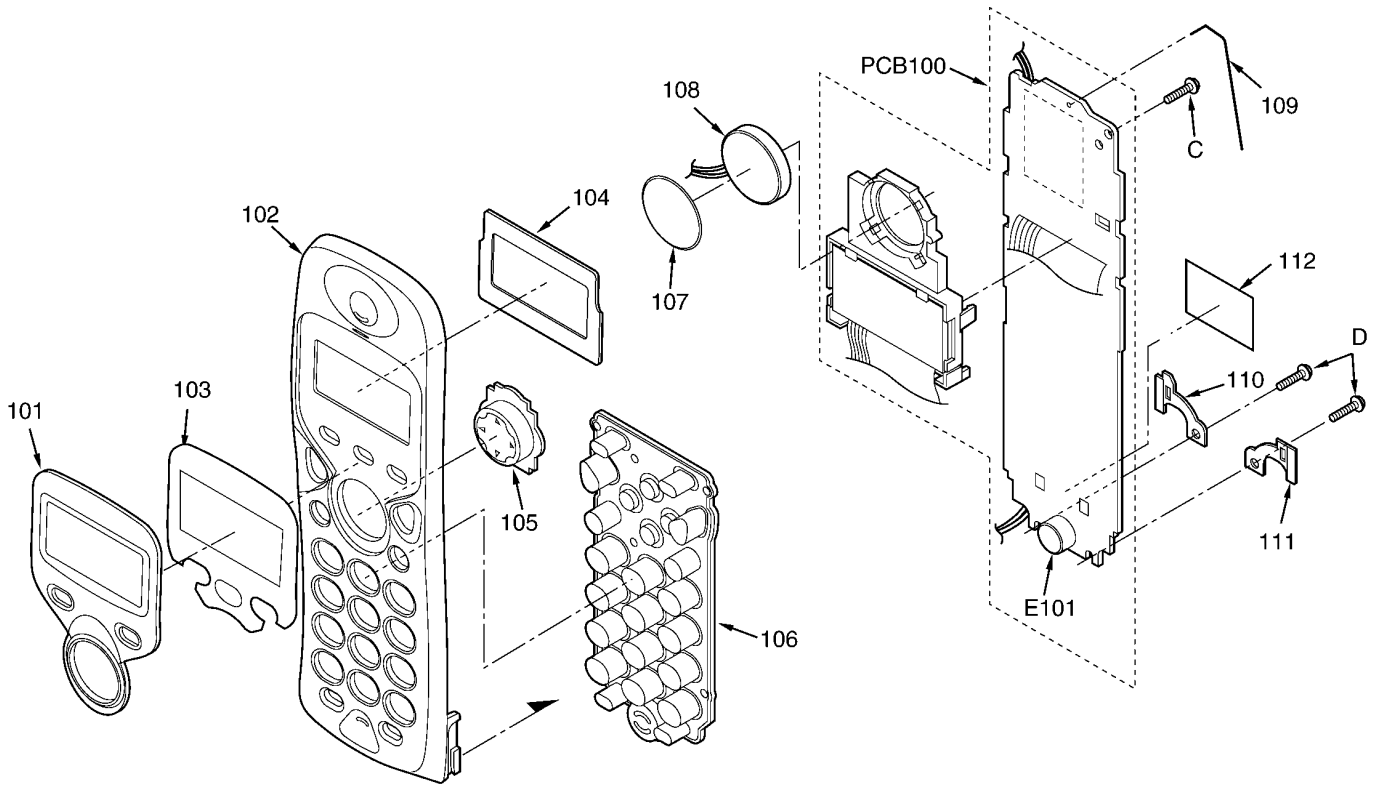
31 CABINET AND ELECTRICAL PARTS LOCATION (HANDSET)

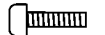
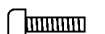

Ref.No.	Part No.	Figure
B	XTB2+10G	 φ2 × 10mm
C	XTB2+8G	 φ2 × 8mm
D	XTB2+8G	 φ2 × 8mm

32 CABINET AND ELECTRICAL PARTS LOCATION (CHARGER UNIT)

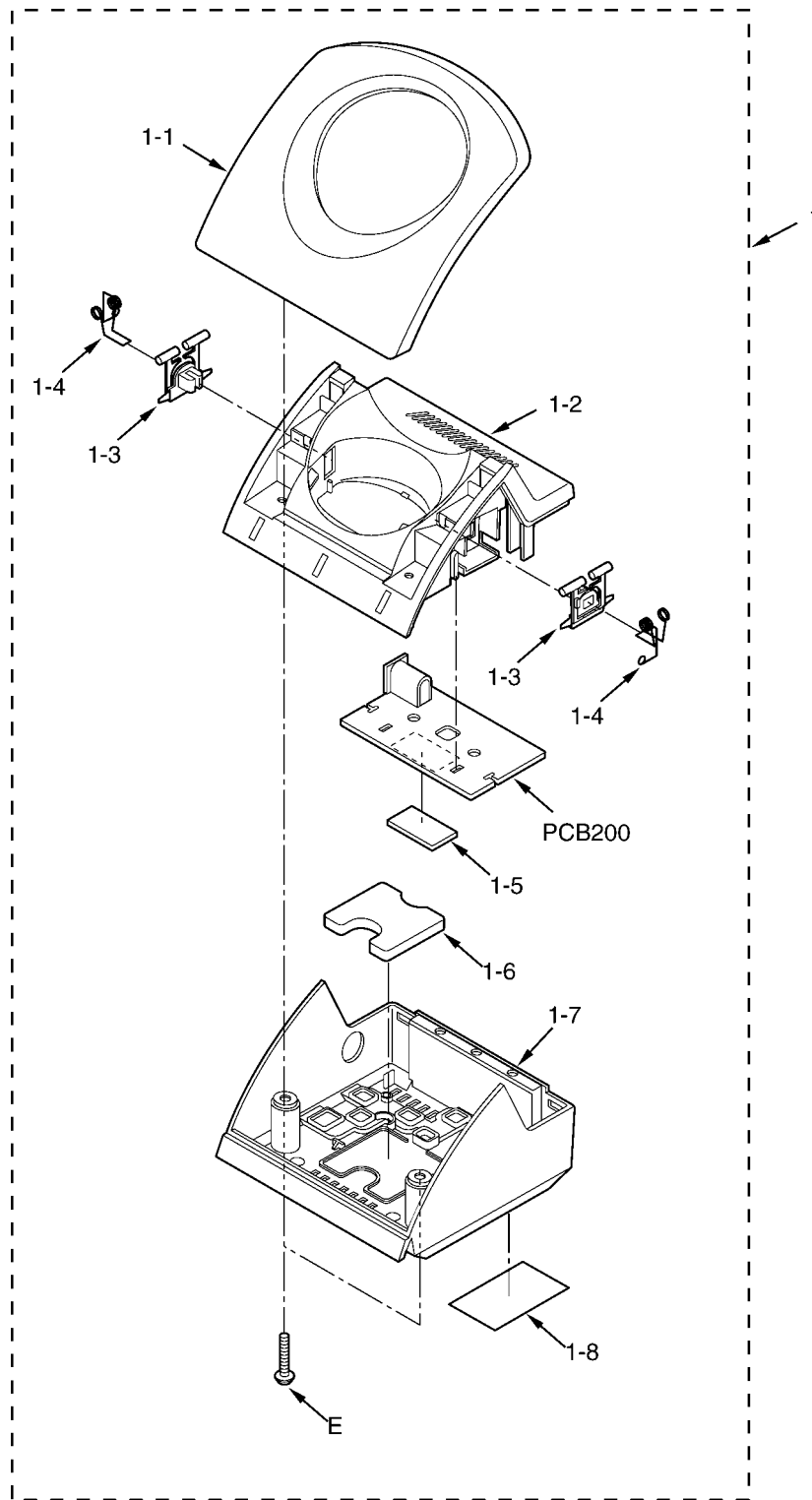

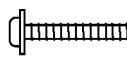
Ref.No.	Part No.	Figure
E	XTW26+14P	 φ 2.6 × 14mm

33 ACCESSORIES AND PACKING MATERIALS

33.1. KX-TCD410RUM/RUS

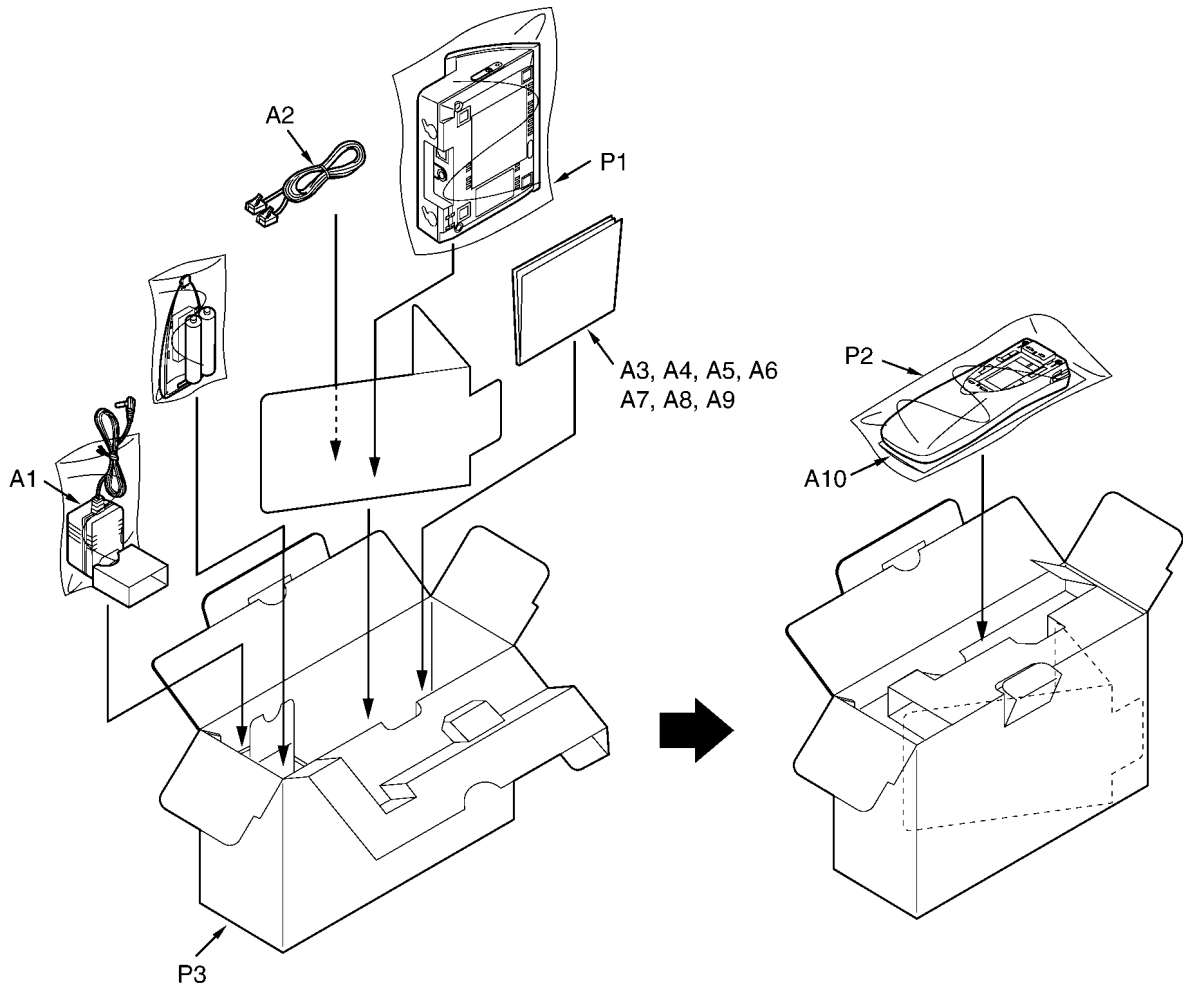

33.2. KX-TCD412RUM/RUS

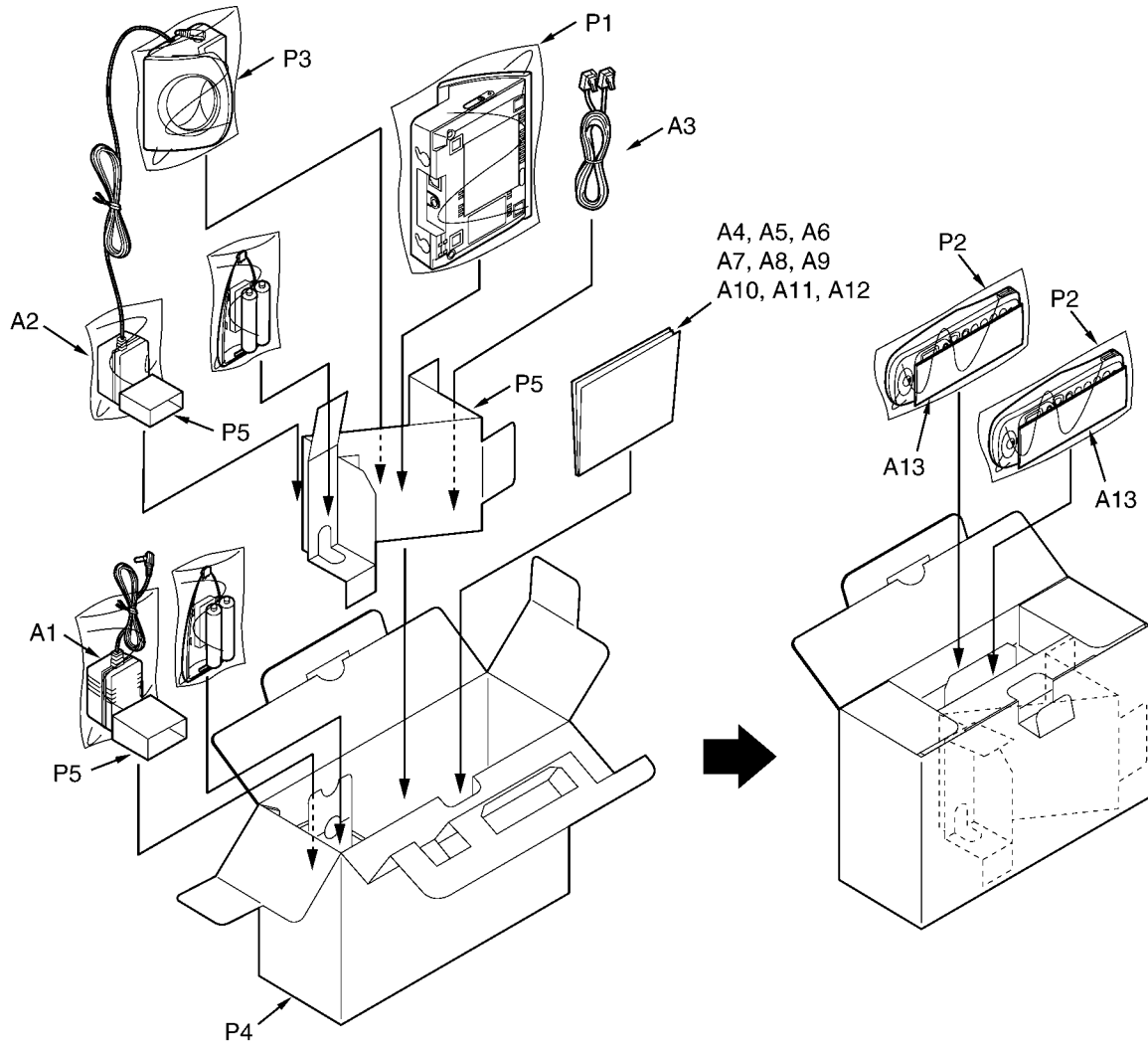

33.3. KX-A142RUM/RUS

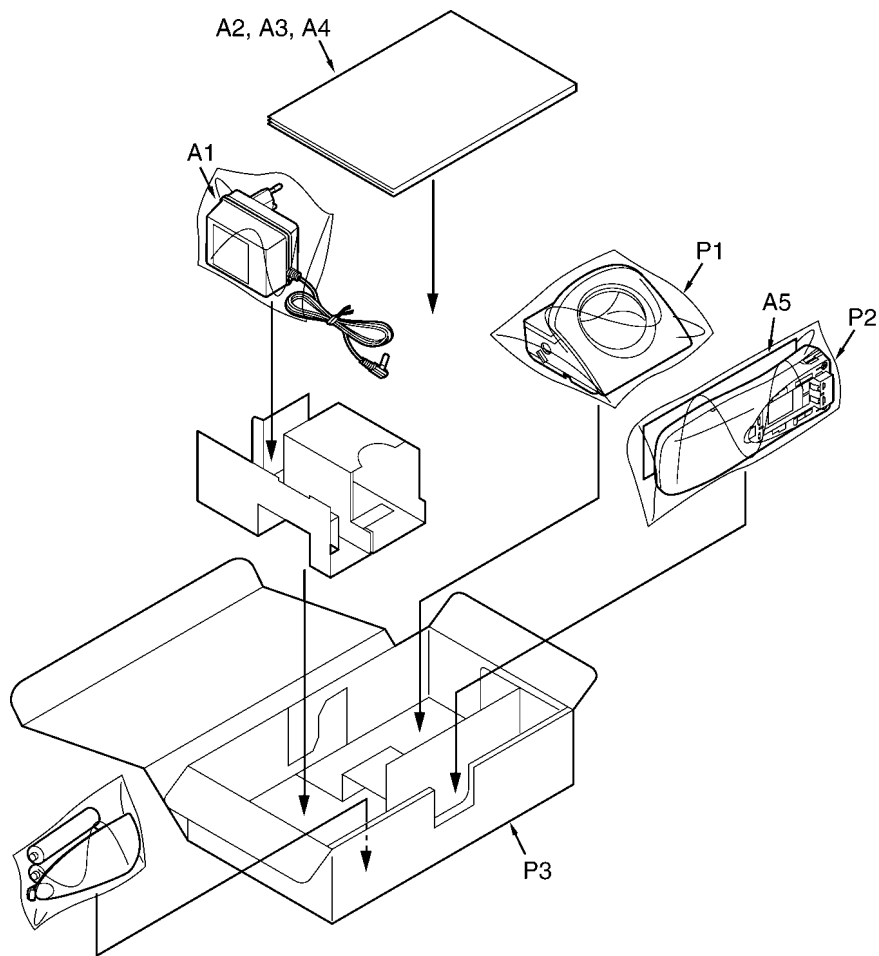

34 TERMINAL GUIDE OF THE ICs, TRANSISTORS AND DIODES

34.1. Base Unit

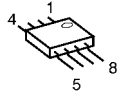
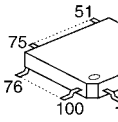
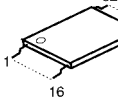
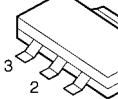
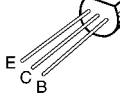
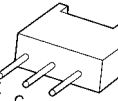
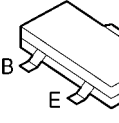
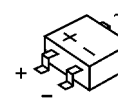
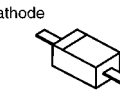
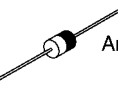
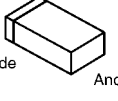
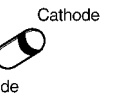
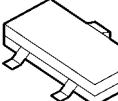
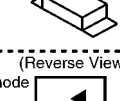
 <p>PQWI1D410RUH</p>	 <p>C1CB00001608</p>	 <p>C3FBKC000105</p>	 <p>PQVILM1117MP</p>	 <p>2SA1625</p>
 <p>2SD1994A</p>	 <p>B1ADGE000004, PQVTBF822T7 PQVTDTC143K, B1ABCE000009</p>		 <p>PQVDS1ZB60F1</p>	 <p>Cathode Anode MAZY30000L</p>
 <p>Cathode Anode B0JAME000085</p>	 <p>Cathode Anode MA2Z74800L MAZ80470ML</p>	 <p>Cathode Anode PQVDBZV55C02</p>	 <p>B0DDCM000001</p>	 <p>(Reverse View) Anode Cathode LNJ308G8JRA</p>

34.2. Handset

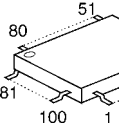
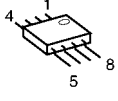
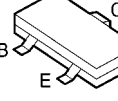
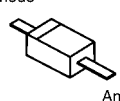
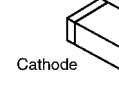
 <p>C2HBAK000005</p>	 <p>PQWI1D410RUR</p>	 <p>PQVTFDN335N, B1ADGE000004 UN5216</p>	 <p>Cathode Anode B0JCME000035</p>
 <p>Cathode Anode MA2Z74800L MAZ83900ML</p>			

34.3. Charger Unit

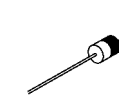
 <p>Cathode Anode B0JAME000085</p>

35 REPLACEMENT PARTS LIST

1. RTL (Retention Time Limited)

Note:

The marking (RTL) indicates that the Retention Time is limited for this item.

After the discontinuation of this assembly in production, the item will continue to be available for a specific period of time. The retention period of availability is dependant on the type of assembly, and in accordance with the laws governing part and product retention. After the end of this period, the assembly will no longer be available.

2. Important safety notice

Components identified by the Δ mark indicates special characteristics important for safety. When replacing any of these components, only use specified manufacture's parts.

3. The S mark means the part is one of some identical parts. For that reason, it may be different from the installed part.

4. ISO code (Example: ABS-94HB) of the remarks column shows quality of the material and a flame resisting grade about plastics.

5. RESISTORS & CAPACITORS

Unless otherwise specified;

All resistors are in ohms (Ω) K=1000 Ω , M=1000k Ω

All capacitors are in MICRO FARADS (μ F)P= μ F

*Type & Wattage of Resistor

Type

ERC:Solid ERDS:Carbon ERJ:Chip	ERX:Metal Film ERG:Metal Oxide ER0:Metal Film	PQ4R:Chip ERS:Fusible Resistor ERF:Cement Resistor
--------------------------------------	---	--

Wattage

10,16:1/8W	14,25:1/4W	12:1/2W	1:1W	2:2W	3:3W
------------	------------	---------	------	------	------

*Type & Voltage Of Capacitor

Type

ECFD:Semi-Conductor ECQS:Styrol ECUV,PQCUV,ECUE:Chip ECQMS:Mica	ECCD,ECKD,ECBT,F1K,ECUV: Ceramic ECQE,ECQV,ECQG: Polyester ECEA,ECST,EEE: Electlytic ECQP: Polypropylene
--	---

Voltage

ECQ Type	ECQG ECQV Type	ECSZ Type	Others		
1H:50V 2A:100V 2E:250V 2H:500V	05:50V 1:100V 2:200V	0F:3.15V 1A:10V 1V:35V 0J:6.3V	0J :6.3V 1A :10V 1C :16V 1E,25:25V	1V :35V 50,1H:50V 1J :16V 2A :100V	

35.1. Base Unit

35.1.1. Cabinet and Electrical Parts

Ref. No.	Part No.	Part Name & Description	Remarks
1	PQGG10154W5	GRILLE (for KX-TC410RUM) (for KX-TC412RUM)	ABS-HB
1	PQGG10154W4	GRILLE (for KX-TC410RUS) (for KX-TC412RUS)	ABS-HB
2	PQKM10586Z4	CABINET BODY (for KX-TC410RUM) (for KX-TC412RUM)	ABS-HB
2	PQKM10586Z3	CABINET BODY (for KX-TC410RUS) (for KX-TC412RUS)	ABS-HB

Ref. No.	Part No.	Part Name & Description	Remarks
3	PQHR10962Z	OPTIC CONDUCTIVE PARTS, LED LENS	
4	PQJT10203Z	TERMINAL	
5	PQKE10356Z1	GUIDE, CHARGE TERMINAL CASE	POM-HB
6	PQSA10131Z	ANTENNA, MAIN	
7	PQSA10132Z	ANTENNA, SUB	
8	PQYF10560Z4	CABINET COVER (for KX-TC410RUM) (for KX-TC412RUM)	ABS-HB
8	PQYF10560Z3	CABINET COVER (for KX-TC410RUS) (for KX-TC412RUS)	ABS-HB
9	PQGT16018Z	NAME PLATE (for KX-TC410RUM) (for KX-TC412RUM)	
9	PQGT16019Z	NAME PLATE (for KX-TC410RUS) (for KX-TC412RUS)	

35.1.2. Main P.C.Board Parts

Ref. No.	Part No.	Part Name & Description	Remarks
PCB1	PQWP1D410RUH	MAIN P.C.BOARD ASS'Y (RTL) (ICs)	
IC1	PQWI1D410RUH	IC	
IC2	C1CB00001608	IC	
IC4	C3FBKC000105	IC	
Q9	PQVILM1117MP	IC	S
		(TRANSISTORS)	
Q2	2SA1625	TRANSISTOR (SI)	S
Q3	PQVTBF822T7	TRANSISTOR (SI)	
Q6	2SD1994A	TRANSISTOR (SI)	
Q7	B1ABCE000009	TRANSISTOR (SI)	
Q8	B1ADGE000004	TRANSISTOR (SI)	
Q10	PQVTDTC143K	TRANSISTOR (SI)	
		(DIODES)	
D2	PQVDS1ZB60F1	DIODE (SI)	S
D3	MAZY30000L	DIODE (SI)	
D4	BOJAME000085	DIODE (SI)	
D5	MAZ274800L	DIODE (SI)	
D7	PQVDBZV55C02	DIODE (SI)	
D8	MAZ80470ML	DIODE (SI)	
D9	MAZ80470ML	DIODE (SI)	
D10	MAZ80470ML	DIODE (SI)	
DA1	B0DDCM000001	DIODE (SI)	
LED1	LNJ308G8JRA	LED	
		(COILS)	
L1	PQLQR4D4R7K	COIL	
L3	PQLQR2M33NK	COIL	
L8	PQLQR2M1N8S	COIL	S
		(JACKS)	
J1	PQJJ1TB26Z	JACK, MODULATOR	S
J2	PQJJ1B4Y	JACK, DC	
		(RESISTORS)	
R1	ERJ3GEYJ155	1.5M	
R2	ERJ3GEYJ155	1.5M	
R3	ERJ3GEYJ224	220K	
R4	ERJ3GEYJ184	180K	
R5	ERJ3GEYJ224	220K	
R6	ERJ3GEYJ184	180K	
R7	ERJ3GEYJ104	100K	
R8	ERJ3GEYJ272	2.7K	
R9	ERJ3GEYJ103	10K	
R10	ERJ3GEYJ222	2.2K	
R12	PQ4R18XJ000	0	S
R16	ERJ3GEYJ133	13K	
R18	ERJ3GEYJ392	3.9K	
R19	ERJ12YJ220	22	
R20	ERJ12YJ560	56	
R21	ERJ3GEYJ104	100K	
R22	ERJ3GEYJ333	33K	
R23	ERJ3GEYJ560	56	
R24	PQ4R18XJ100	10	S
R25	ERJ3GEYJ151	150	

Ref. No.	Part No.	Part Name & Description	Remarks
R26	ERJ3GEYJ103	10K	
R27	ERJ3GEYJ222	2.2K	
R28	ERJ3GEYJ751	750	
R29	ERJ3GEYJ101	100	
R30	ERJ3GEYJ101	100	
R31	ERJ3GEYJ101	100	
R32	ERJ3GEYJ560	56	
R33	PQ4R10XJ102	1K	S
R37	ERJ3GEY0R00	0	
R38	ERJ3GEYJ330	33	
R39	ERJ3GEY0R00	0	
R40	ERJ3GEY0R00	0	
R41	ERJ3GEYJ101	100	
R42	ERJ3GEYJ221	220	
R43	ERJ1WYJ330	33	
R44	ERJ1WYJ330	33	
R53	ERJ3GEYJ565	5.6M	
R54	ERJ3GEYJ184	180K	
R57	ERJ3GEYJ103	10K	
R58	ERJ3GEYJ103	10K	
R59	ERJ3GEYJ105	1M	
R66	ERJ3GEYJ390	39	
R67	ERJ3GEYJ390	39	
R68	ERJ3GEYJ151	150	
R77	PQ4R10XJ000	0	S
R78	ERJ3GEYJ181	180	
R79	ERJ3GEYJ181	180	
R80	ERJ3GEYJ222	2.2K	
R81	ERJ3GEYJ565	5.6M	
R82	ERJ3GEYJ184	180K	
R83	ERJ3GEYJ222	2.2K	
R84	ERJ3GEYJ103	10K	
R85	ERJ8GEYJ123	12K	
L4	PQ4R18XJ000	0	S
		(CAPACITORS)	
C1	ECKD2H681KB	680P	S
C2	ECKD2H681KB	680P	S
C3	ECQE2223KF	0.022	
C4	ECQE2223KF	0.022	
C7	ECUV2H332KB	0.0033	
C11	ECUV1C273KBV	0.027	
C12	PQCUV1C474KB	0.47	
C13	PQCUV1A105KB	1	
C14	PQCUV1C224KB	0.22	
C15	ECEA1HKS100	10	S
C18	ECUV1H100DCV	10P	
C19	ECUV1H100DCV	10P	
C20	ECUV1C104KBV	0.1	
C21	ECUV1H100DCV	10P	
C22	PQCUV1C224KB	0.22	
C23	ECUV1C104KBV	0.1	
C24	ECUV1C104KBV	0.1	
C25	ECEA1CKS100	10	S
C26	ECUV1C104KBV	0.1	
C27	ECUV1C104KBV	0.1	
C28	ECUV1C683KBV	0.068	
C29	ECUV1C683KBV	0.068	
C30	ECUV1H182KBV	0.0018	
C31	ECKD2H681KB	680P	S
C32	ECUV1H270JCV	27P	
C33	ECUV1H1R0CCV	1	
C34	ECUV1C104KBV	0.1	
C35	ECUV1H333KBV	0.033	S
C36	ECUV1C104KBV	0.1	
C37	ECUV1C104KBV	0.1	
C38	ECUV1C104KBV	0.1	
C39	PQCUV1E104MD	0.1	S
C40	ECEA1AKA101	100	
C41	ECEA0JKA101	100	
C42	ECUV1H101JCV	100P	
C43	ECUV1H100DCV	10P	
C44	ECUV1C104KBV	0.1	
C45	ECUV1C104KBV	0.1	

Ref. No.	Part No.	Part Name & Description	Remarks
C46	ECUV1C104KBV	0.1	
C47	ECUV1H101JCV	100P	
C48	ECUV1H330JCV	33P	
C49	ECUV1H103KBV	0.01	
C50	ECUV1H100DCV	10P	
C52	ECUV1H101JCV	100P	
C54	G1C2N7Z00008	COIL	
C55	ECUV1H100DCV	10P	
C56	ECUV1H100DCV	10P	
C57	PQLQR2M1N8S	COIL	S
C58	PQLQR2M1N8S	COIL	S
C59	ECUV1H101JCV	100P	
C61	ECUV1H100DCV	10P	
C64	ECUV1H102KBV	0.001	
C65	ECUV1H2R0CCV	2	
C66	ECUV1H060DCV	6P	S
C67	ECUV1A475KB	4.7	
C68	ECUV1A475KB	4.7	
C69	ECUV1H2R0CCV	2	
C72	ECUV1H2R0CCV	2	
C73	ECUV1H100DCV	10P	
C74	ECUV1H103KBV	0.01	
C76	ECUV1C104KBV	0.1	
C77	ECQE2E474KZ	0.47	S
C78	ECUV1H102KBV	0.001	
C79	ECUV1H102KBV	0.001	
C80	ECUV1H060DCV	6P	S
C81	ECUV1H2R0CCV	2	
C82	ECUV1H030CCV	3P	
C83	ECUV1H1R0CCV	1	
C84	ECUV1H1R0CCV	1	
C85	ECUV1H1R0CCV	1	
C87	ECUV1H101JCV	100P	
C88	ECUV1H100DCV	10P	
C89	ECUV1H100DCV	10P	
C90	ECUV1H100DCV	10P	
C91	ECUV1H1R0CCV	1	
		(OTHERS)	
IC3	J3FKK0000003	RF UNIT	
S1	K0H1BB000018	SPECIAL SWITCH, TACTILE	
SA1	PQVDDSS301L	VARISTOR (SURGE ABSORBER)	S
X1	H0D103500003	CRYSTAL OSCILLATOR	

35.2. Handset

35.2.1. Cabinet and Electrical Parts

Ref. No.	Part No.	Part Name & Description	Remarks
101	PQGP10225Z4	PANEL, LCD (for KX-A141RUM) (for KX-A142RUM)	AS-HB
101	PQGP10225Y3	PANEL, LCD (for KX-A141RUS) (for KX-A142RUS)	AS-HB
102	PQKM10587W5	CABINET BODY (for KX-A141RUM)	ABS-HB
102	PQKM10587W4	CABINET BODY (for KX-A141RUS)	ABS-HB
102	PQKM10587V5	CABINET BODY (for KX-A142RUM)	ABS-HB
102	PQKM10587V4	CABINET BODY (for KX-A142RUS)	ABS-HB
103	PQHS10553Z	TAPE, DOUBLE SIDE	
104	PQHS10554Z	SPACER, LCD	
105	PQBC10375Z1	PUSH BUTTON, NAVI	
106	PQSX10224Q	KEYBOARD SWITCH, 20KEY	
107	PQHS10467Z	COVER, SP NET	
108	L0AD02A00016	SPEAKER	
109	PQSA10133Z	ANTENNA	
110	PQJT10204Z	TERMINAL (L)	
111	PQJT10205Z	TERMINAL (R)	
112	PQHX11202Z	INSULATOR	
113	PQJC10058Z	BATTERY TERMINAL (+)	
114	PQJC10057Z	BATTERY TERMINAL (-)	
115	PQJC10056Z	BATTERY TERMINAL	
116	PQKF10582Z5	CABINET COVER (for KX-A141RUM) (for KX-A142RUM)	ABS-HB
116	PQKF10582Z4	CABINET COVER (for KX-A141RUS) (for KX-A142RUS)	ABS-HB

Ref. No.	Part No.	Part Name & Description	Remarks
117	PQGT16020Z	NAME PLATE (for KX-A141RUM)	
117	PQGT16105Z	NAME PLATE (for KX-A142RUM)	
117	PQGT16021Z	NAME PLATE (for KX-A141RUS)	
117	PQGT16104Z	NAME PLATE (for KX-A142RUS)	
118	PQHX11204Z	PLASTIC PARTS, BATTERY COVER SHEET	
119	PQHS10561Y	SPACER, BATTERY COVER	
120	PQKK10134Z5	LID, BATTERY (for KX-A141RUM) (for KX-A142RUM)	ABS-HB
120	PQKK10134Z4	LID, BATTERY (for KX-A141RUS) (for KX-A142RUS)	ABS-HB

35.2.2. Main P.C.Board Parts

Ref. No.	Part No.	Part Name & Description	Remarks
PCB100	PQWP1D410RUR	MAIN P.C.BOARD ASS'Y (RTL) (ICs)	
IC1	C2HBAK000005	IC	
IC2	PQWI1D410RUR	IC (TRANSISTORS)	S
Q1	PQVTFDN335N	TRANSISTOR (SI)	S
Q2	B1ADGE000004	TRANSISTOR (SI)	
Q3	UN5216	TRANSISTOR (SI) (DIODES)	
D1	BOJCM000035	DIODE (SI)	
D3	MA2Z74800L	DIODE (SI)	
D4	MAZ83900ML	DIODE (SI)	
D6	MA2Z74800L	DIODE (SI)	
D7	MA2Z74800L	DIODE (SI) (COILS)	
L2	G1A470L00001	COIL	
L3	PQLQR4D4R7K	COIL	
L4	G1C100MA0072	COIL	
L5	G1C100MA0072	COIL	
F1	PQLQR2M5N6K	COIL (RESISTORS)	S
R1	ERJ3GEYJ222	2. 2K	
R2	ERJ8BQJR30	0. 3	
R3	ERJ3GEYJ560	56	
R4	ERJ3GEYJ103	10K	
R5	ERJ3GEYJ331	330	
R6	ERJ3GEYJ332	3. 3K	
R7	ERJ3GEYJ331	330	
R8	ERJ3GEYJ331	330	
R11	ERJ3GEYOR00	0	
R17	ERJ3GEYOR00	0	
R18	ERJ3GEYJ330	33	
R19	ERJ3GEYJ153	15K	
R20	ERJ3GEYOR00	0	
R21	ERJ6RSJR10V	0. 1	
R22	ERJ3GEYOR00	0	
R23	ERJ3GEYJ2R2	2. 2	
R24	ERJ3GEYOR00	0 (CAPACITORS)	
C2	ECUV1A475KB	4. 7	
C3	ECUV1C104KBV	0. 1	
C4	ECUV1C104KBV	0. 1	
C5	ECST0JY475	4. 7	
C6	ECUV1H100DCV	10P	
C7	ECUV1C104KBV	0. 1	
C8	ECUV1H100DCV	10P	
C10	ECUV1H100DCV	10P	
C11	ECUV1H100DCV	10P	
C12	ECUV1H100DCV	10P	
C14	EEE1AA221P	220	
C15	EEE1AA221P	220	
C16	ECUV1H1R0CCV	1	
C17	ECUV1H180JCV	18P	
C18	ECUV1C104KBV	0. 1	
C20	ECUV1C104KBV	0. 1	
C21	ECUV1C104KBV	0. 1	
C22	ECUV1C104KBV	0. 1	
C23	ECUV1C104KBV	0. 1	

Ref. No.	Part No.	Part Name & Description	Remarks
C24	ECUV1C104KBV	0. 1	
C26	ECUV1C104KBV	0. 1	
C27	ECUV1C104KBV	0. 1	
C28	ECUV1C104KBV	0. 1	
C29	ECUV1C104KBV	0. 1	
C30	ECUV1C104KBV	0. 1	
C31	ECUV1H100DCV	10P	
C33	ECUV1A225KB	2. 2	
C54	ECUV1H100DCV	10P	
C55	ECUV1H020CCV	2P	
C56	ECUV1H020CCV	2P	
C57	ECUV1H330JCV	33P	
C60	ECUV1A475KB	4. 7	
C62	ECUV1A105KBV	1	
C63	ECUV1H100DCV	10P	
C64	ECUV1A105KBV	1	
C65	ECUV1H020CCV	2P	
C66	ECUV1H020CCV	2P (OTHERS)	
E101	LOCBAB000052	MICROPHONE	
IC3	J3FKK0000003	RF UNIT	
X1	HOD103500002	CRYSTAL OSCILLATOR	

35.3. Charger Unit

35.3.1. Cabinet and Electrical Parts

Ref. No.	Part No.	Part Name & Description	Remarks
1	PQLV30018ZM1	ACCESSORY PARTS, CHARGER UNIT (for KX-A142RUM)	
1	PQLV30018ZS1	ACCESSORY PARTS, CHARGER UNIT (for KX-A142RUS)	
1-1	PQGG10155Y5	GRILLE (for KX-A142RUM)	ABS-HB
1-1	PQGG10155Y4	GRILLE (for KX-A142RUS)	ABS-HB
1-2	PQKM10591Z3	CABINET BODY (for KX-A142RUM)	PS-HB
1-2	PQKM10591Z2	CABINET BODY (for KX-A142RUS)	PS-HB
1-3	PQKE10356Z1	GUIDE, CHARGE TERMINAL CASE	POM-HB
1-4	PQJT10206Z	CHARGE TERMINAL	
1-5	PQHX10991Z	CUSHION, URETHANE FORM	
1-6	PQMH10426Z	WEIGHT	
1-7	PQYF10563Z3	CABINET COVER (for KX-A142RUM)	PS-HB
1-7	PQYF10563Z2	CABINET COVER (for KX-A142RUS)	PS-HB
1-8	PQGT15735X	NAME PLATE (for KX-A142RUM)	
1-8	PQGT15558X	NAME PLATE (for KX-A142RUS)	

35.3.2. Main P.C.Board Parts

Ref. No.	Part No.	Part Name & Description	Remarks
PCB200	PQWPA142ESCH	MAIN P.C.BOARD ASS'Y (RTL) (DIODE)	
D1	BOJAME000085	DIODE (SI) (JACK)	
CN1	K2EZ2B000040	JACK (RESISTORS)	S
R1	ERJ1WYJ220	22	
R2	ERJ1WYJ270	27	

35.4. Accessories and Packing Materials

35.4.1. KX-TC410RUM/RUS

Ref. No.	Part No.	Part Name & Description	Remarks
A1	PQLV19CEZ	AC ADAPTOR	△
A2	PQJA10075Z	CORD, TELEPHONE	
A3	PQOX13513Z	INSTRUCTION BOOK (for Russian)	

Ref. No.	Part No.	Part Name & Description	Remarks
A4	PQQX13874Z	INSTRUCTION BOOK (for Ukraine)	
A5	PQQW12761Z	QUICK GUIDE (for Russian)	
A6	PQQW13091Z	QUICK GUIDE (for Ukraine)	
A7	PQQW12762Z	LEAFLET (for Russian)	
A8	PQQW13124Z	LEAFLET (for Russian)	
A9	PQQW13125Z	LEAFLET (for Ukraine)	
A10	PQQW12846W	LEAFLET, RECHARGE	
P1	PQPP10100Z	PROTECTION COVER (for Base Unit)	
P2	PQPP10084Z	PROTECTION COVER (for Handset)	
P3	PQPK13952Z	GIFT BOX	

35.4.2. KX-TC412RUM/RUS

Ref. No.	Part No.	Part Name & Description	Remarks
A1	PQLV19CEZ	AC ADAPTOR (for Base Unit)	△
A2	PQLV200CEZ	AC ADAPTOR (for Charger)	△
A3	PQJA10075Z	CORD, TELEPHONE	
A4	PQQX13513Z	INSTRUCTION BOOK (for Russian)	
A5	PQQX13874Z	INSTRUCTION BOOK (for Ukraine)	
A6	PQQW12761Z	QUICK GUIDE (for Russian)	
A7	PQQW13091Z	QUICK GUIDE (for Ukraine)	
A8	PQQW12762Z	LEAFLET (for Russian)	
A9	PQQW13124Z	LEAFLET (for Russian)	
A10	PQQW12916Z	LEAFLET (for Russian)	
A11	PQQW13125Z	LEAFLET (for Ukraine)	
A12	PQQW13092Z	LEAFLET (for Ukraine)	
A13	PQQW12846W	LEAFLET, RECHARGE	
P1	PQPP10100Z	PROTECTION COVER (for Base Unit)	
P2	PQPP10084Z	PROTECTION COVER (for Handset)	
P3	PQPP10086Z	PROTECTION COVER (for Charger)	
P4	PQPK14000Z	GIFT BOX	
P5	PQPD10563Z	CUSHION	

35.4.3. KX-A142RUM/RUS

Ref. No.	Part No.	Part Name & Description	Remarks
A1	PQLV200CEZ	AC ADAPTOR	△
A2	PQQX13710Z	INSTRUCTION BOOK (for Russian)	
A3	PQQX13876Z	INSTRUCTION BOOK (for Ukraine)	
A4	PQQW12798Z	LEAFLET (for Russian)	
A5	PQQW12846W	LEAFLET, RECHARGE	
P1	PQPP10086Z	PROTECTION COVER (for Charger Unit)	
P2	PQPP10084Z	PROTECTION COVER (for Handset)	
P3	PQPK13899Z	GIFT BOX	

35.5. Fixtures and Tools

Part No.	Part Name & Description	Remarks
PQZZTCD705BX	I2C PCB	
PQZZ1CD705BX	RS232C CABLE	
PQZZ2CD705BX	CLIP CABLE	
PQZZ3CD705BX	DC CABLE	
PQZZTCD410E	BATCH FILE	

Note:

See **CHECK PROCEDURE (BASE UNIT)** (P.37), and **CHECK PROCEDURE (HANDSET)** (P.38).

36 SCHEMATIC DIAGRAM (BASE UNIT)

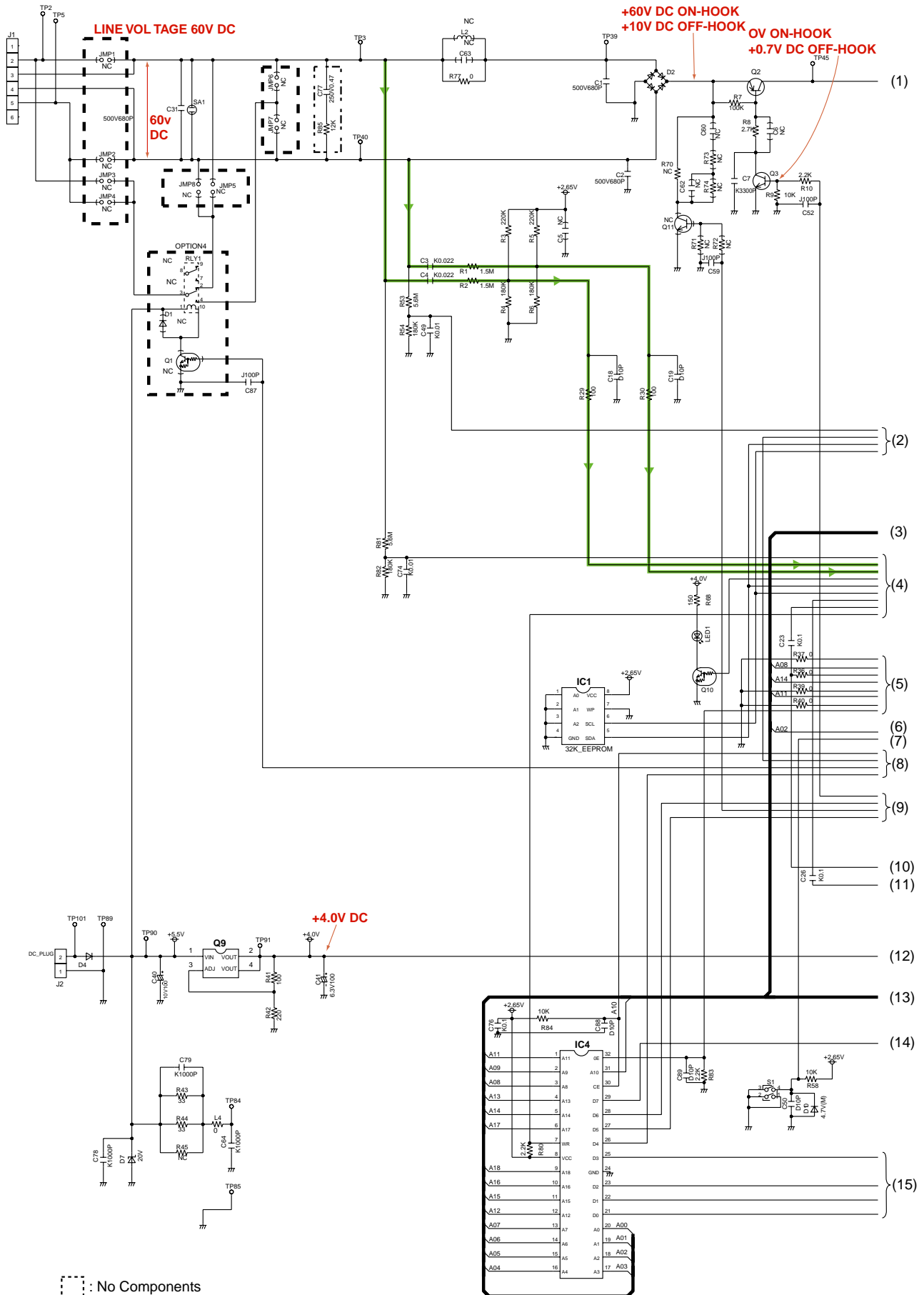

□ : No Components

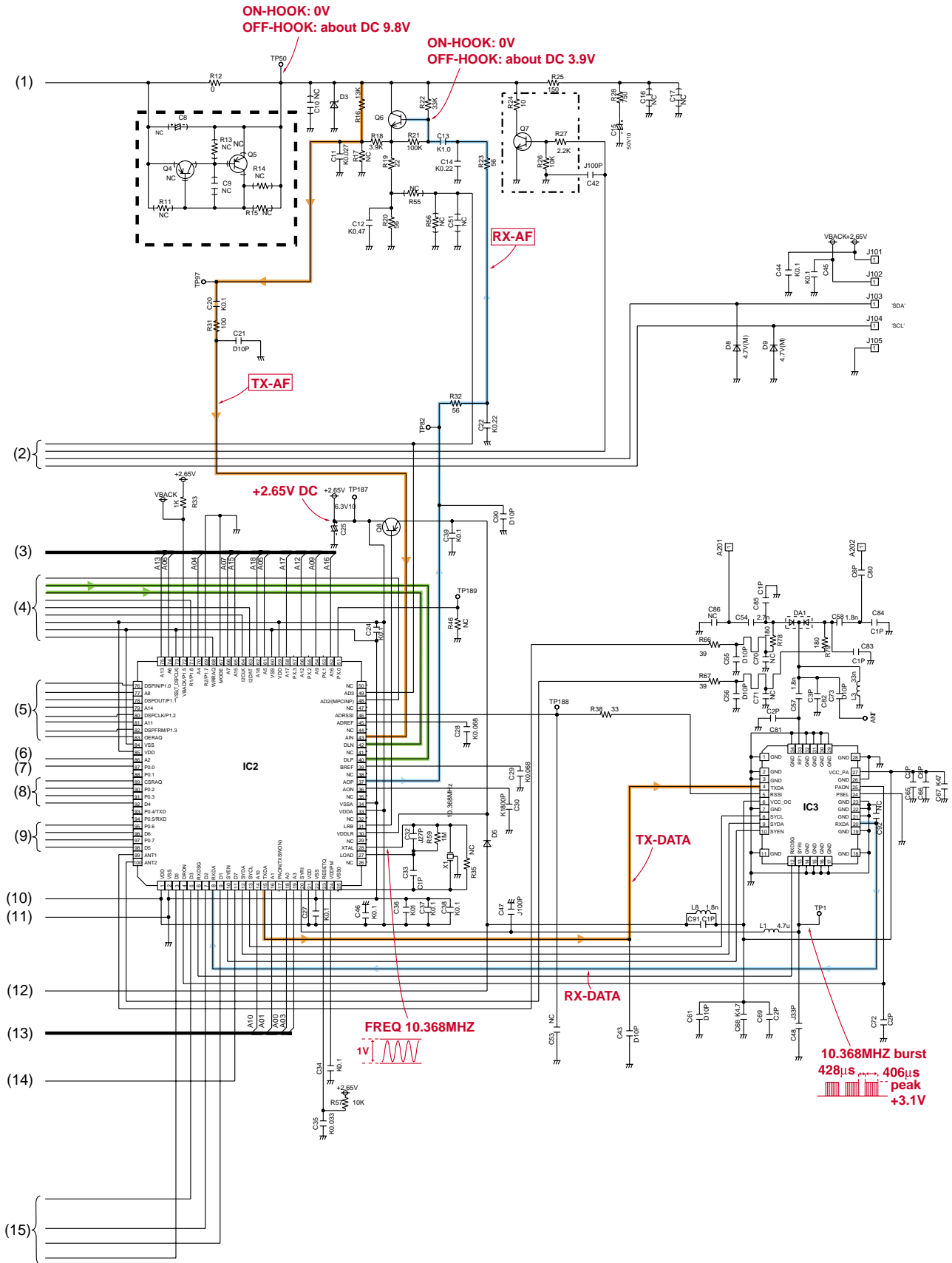

⋯ : No Components

KX-TCD410RUM/RUS&412RUM/RUS SCHEMATIC DIAGRAM (BASE UNIT)

37 SCHEMATIC DIAGRAM (HANDSET)

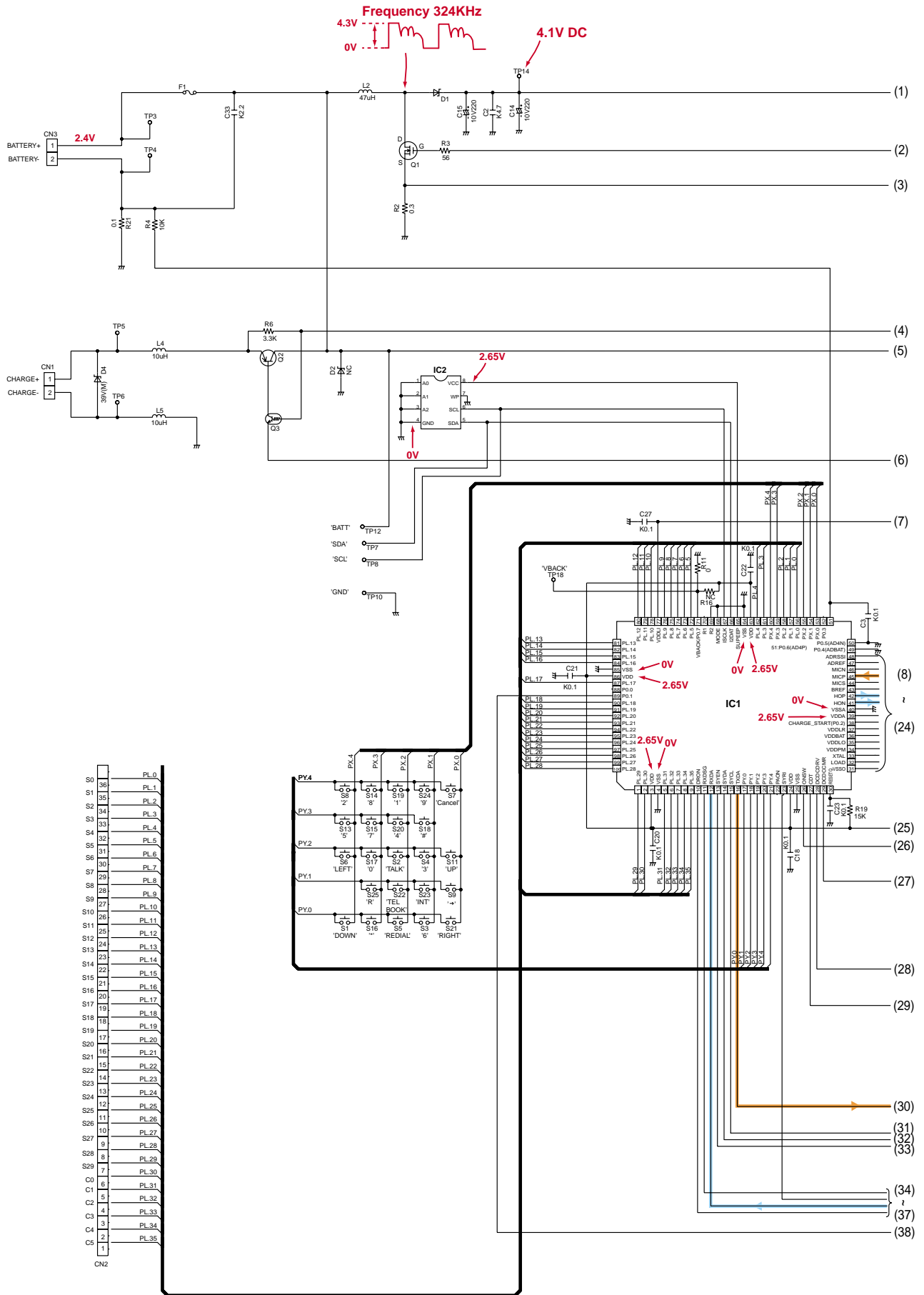

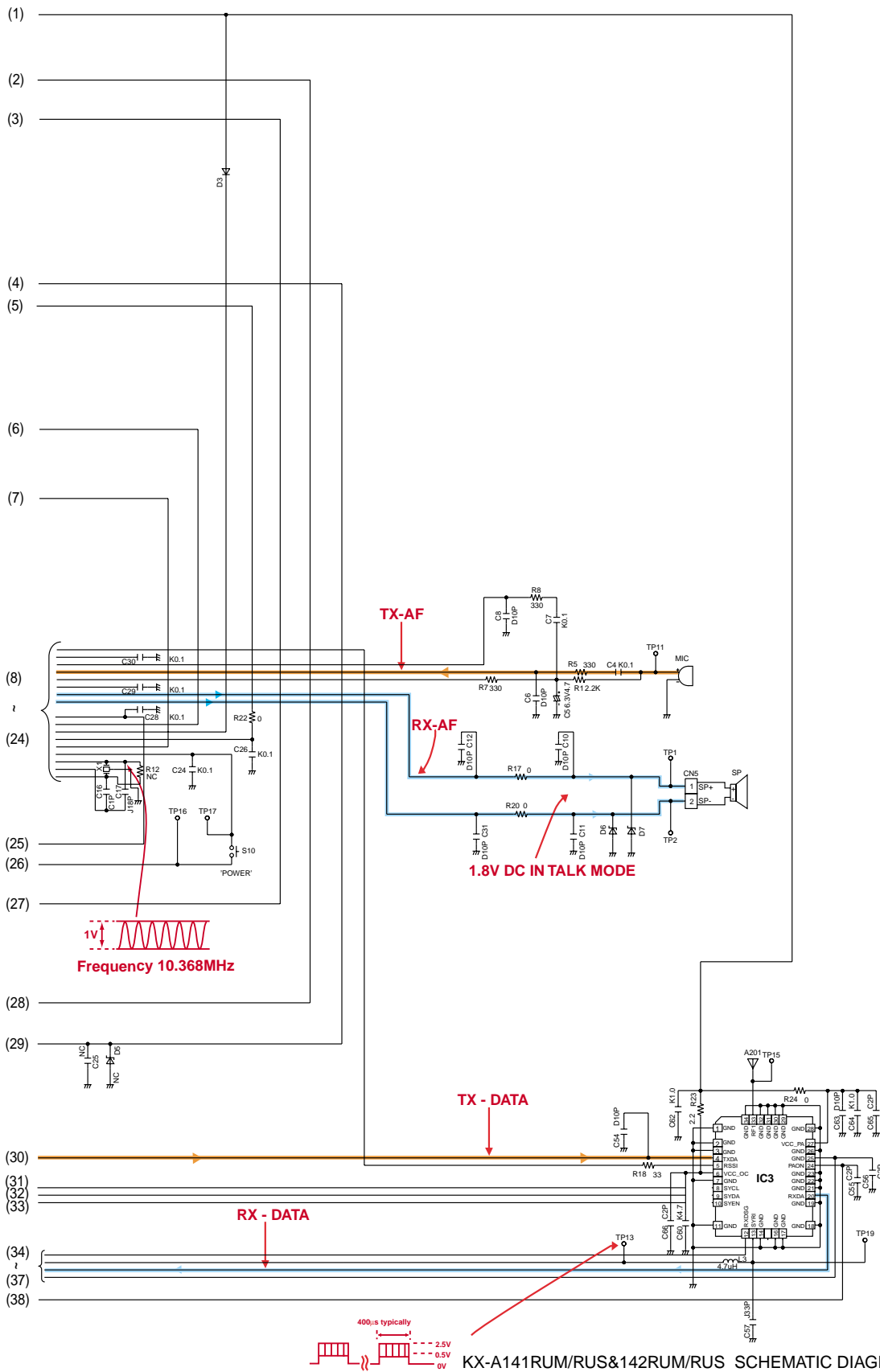

KX-A141RUM/RUS&142RUM/RUS SCHEMATIC DIAGRAM (HANDSET)

38 SCHEMATIC DIAGRAM (CHARGER UNIT)

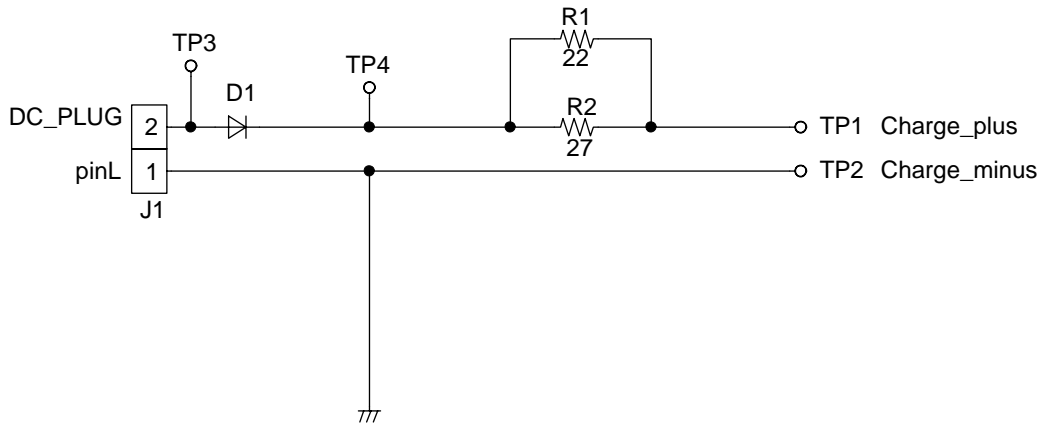

SCHEMATIC DIAGRAM (CHARGER UNIT)

39 CIRCUIT BOARD (BASE UNIT)

39.1. Component View

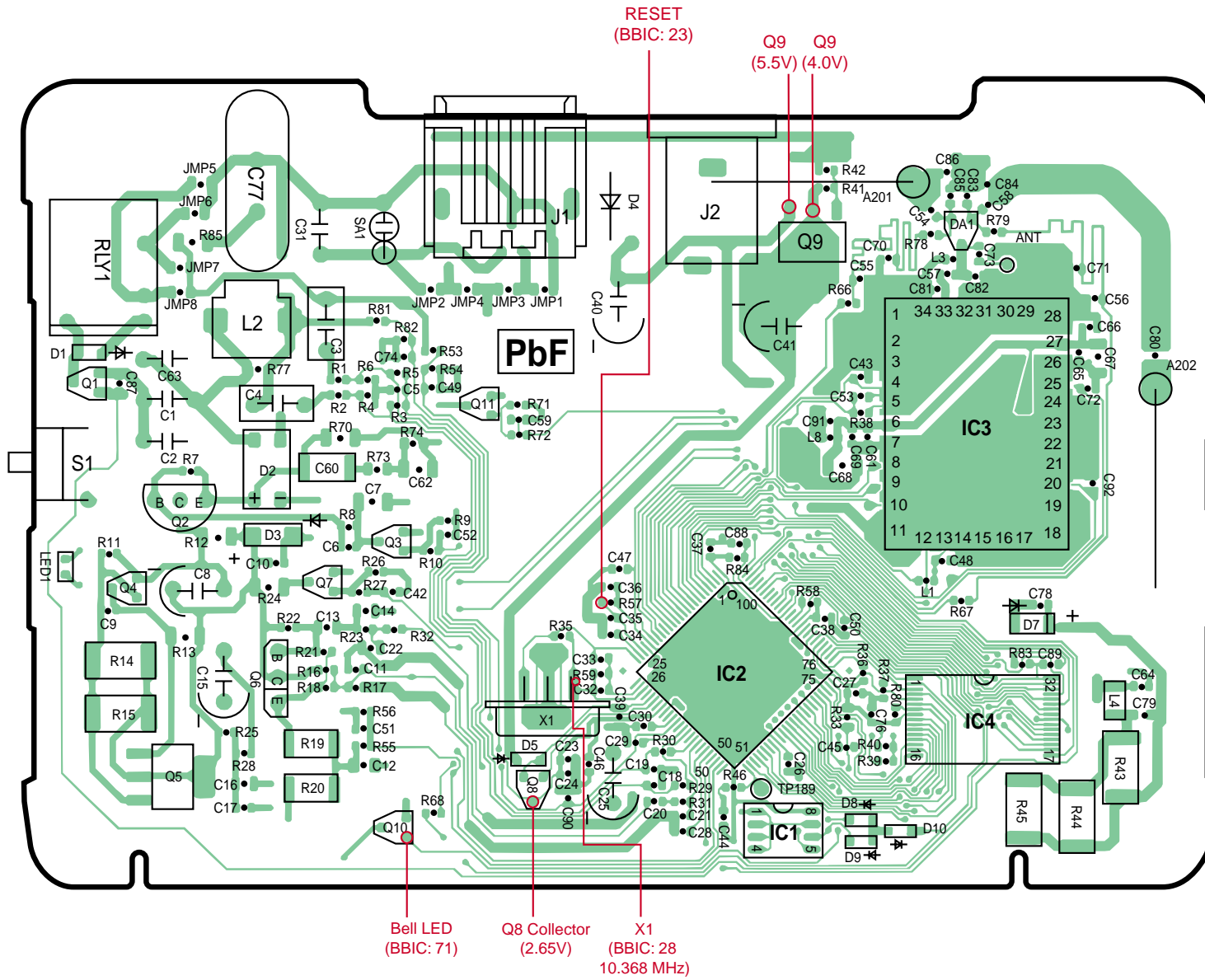

KX-TCD410RUM/RUS&412RUM/RUS CIRCUIT BOARD (BASE UNIT) Component View

39.2. Flow Solder Side View

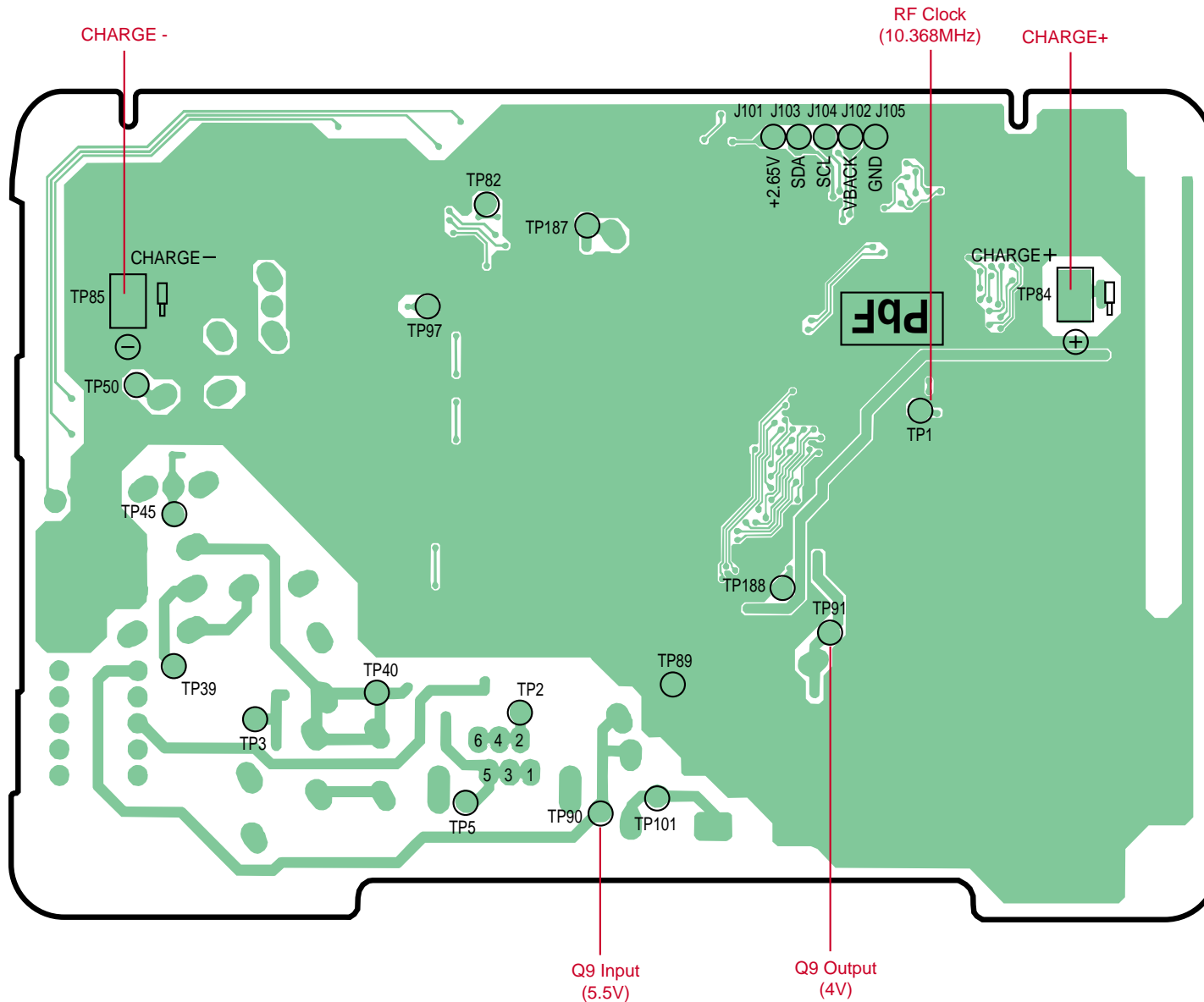

KX-TCD410RUM/RUS&412RUM/RUS CIRCUIT BOARD (BASE UNIT) Flow Solder Side View

40 CIRCUIT BOARD (HANDSET)

40.1. Component View

88

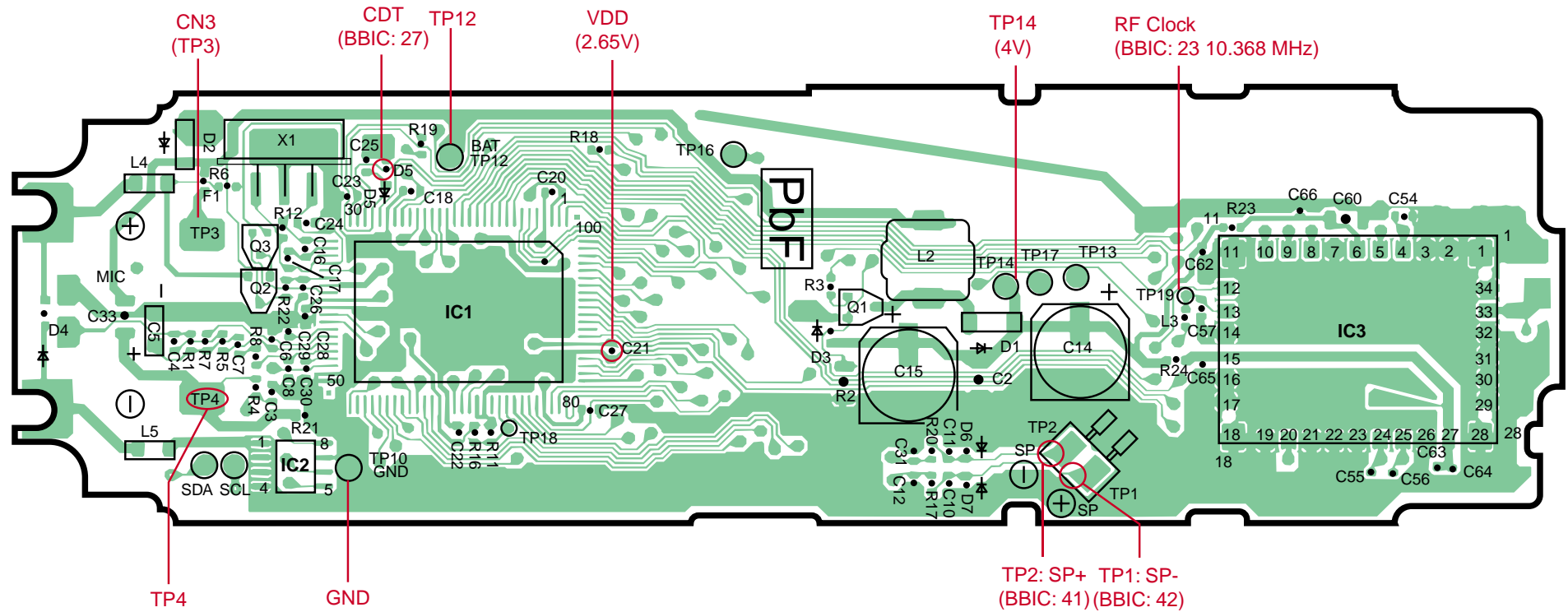

KX-A141RUM/RUS&142RUM/RUS CIRCUIT BOARD (HANDSET) Component View

40.2. Flow Solder Side View

89

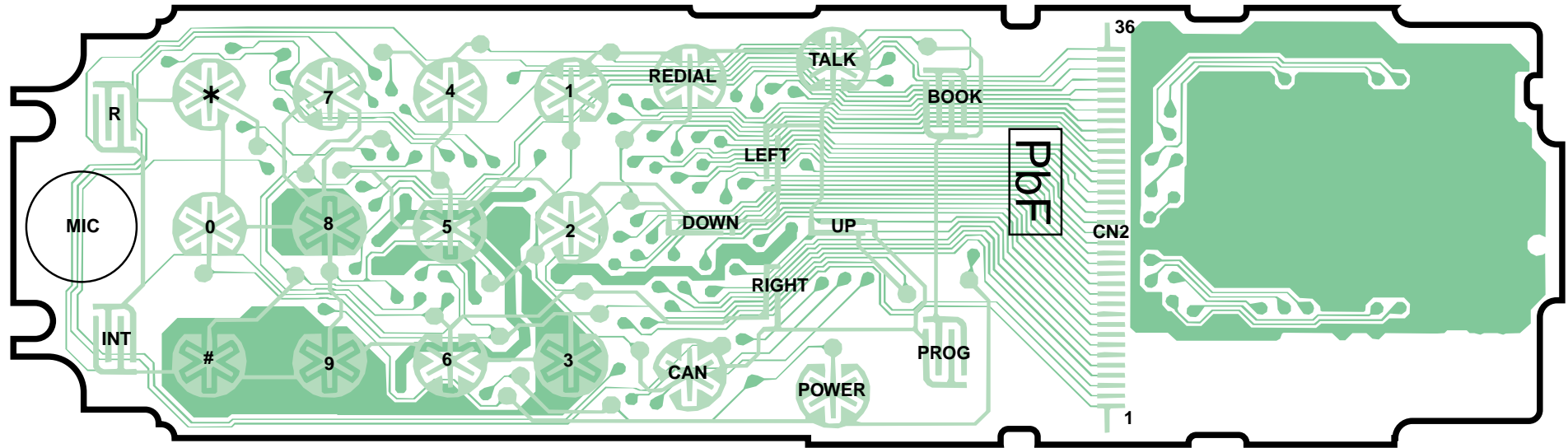

KX-A141RUM/RUS&142RUM/RUS CIRCUIT BOARD (HANDSET) Flow Solder Side View

41 CIRCUIT BOARD (CHARGER UNIT)

41.1. Component View

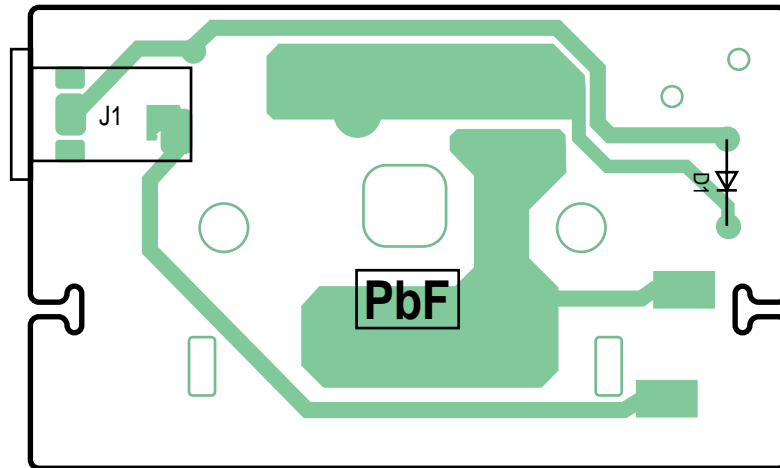

CIRCUIT BOARD (CHARGER UNIT) Component View

41.2. Flow Solder Side View

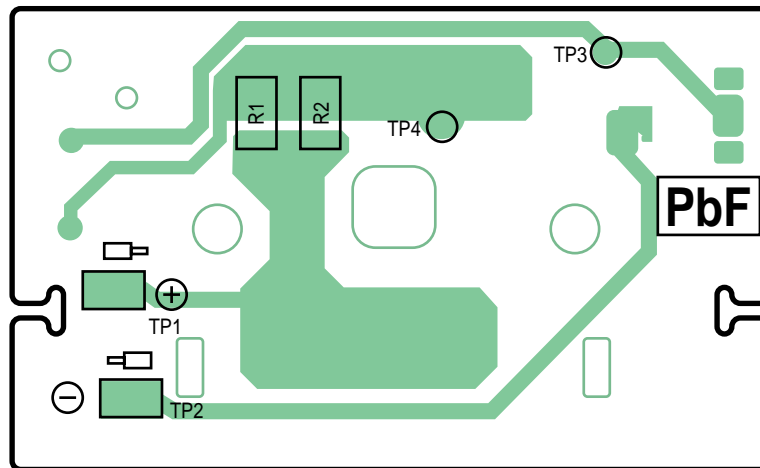

CIRCUIT BOARD (CHARGER UNIT) Flow Solder Side View

M
KXTCD410RUM
KXTCD410RUS
KXTCD412RUM
KXTCD412RUS
KXTCA141RUM
KXTCA141RUS
KXTCA142RUM
KXTCA142RUS