

STR-DE400

SERVICE MANUAL

Ver. 1.2 2007.08

AEP Model
UK Model
E Model
Australian Model



Manufactured under license from Dolby Laboratories.
“Dolby”, “Pro Logic” and the double-D symbol are trademarks of Dolby Laboratories.
“DTS” and “DTS Digital Surround” are registered trademarks of Digital Theater Systems, Inc.

SPECIFICATIONS

Amplifier section

Models of area code AEP, UK, TW, AUS

Stereo Power Output¹⁾, Reference Power Output¹⁾²⁾

6 ohms 20 Hz – 20 kHz, THD 0.09%
55 W + 55 W, 80 W/ch

6 ohms 1 kHz, THD 0.7%
90 W + 90 W, 100 W/ch

6 ohms 1 kHz, THD 10%
120 W + 120 W, 140 W/ch

Models of area code RU

Reference Power Output¹⁾²⁾

6 ohms 1 kHz, THD 10%
100 W/ch

Models of area code TH

Stereo Power Output¹⁾, Reference Power Output¹⁾²⁾

6 ohms 20 Hz – 20 kHz, THD 0.09%
40 W + 40 W¹⁾,
35 W + 35 W³⁾, 60 W/ch

6 ohms 1 kHz, THD 0.7%
65 W + 65 W¹⁾,
60 W + 60 W³⁾, 80 W/ch

6 ohms 1 kHz, THD 10%
85 W + 85 W¹⁾,
75 W + 75 W³⁾, 100 W/ch

Models of area code KR

Stereo Power Output¹⁾, Reference Power Output¹⁾²⁾

6 ohms 20 Hz – 20 kHz, THD 0.09%
55 W + 55 W¹⁾,
50 W + 50 W³⁾, 80 W/ch

6 ohms 1 kHz, THD 0.7%
90 W + 90 W¹⁾,
80 W + 80 W³⁾, 100 W/ch

6 ohms 1 kHz, THD 10%
120 W + 120 W¹⁾,
100 W + 100 W³⁾,
140 W/ch

¹⁾Measured under the following conditions:

Area code	Power requirements
AEP, UK, KR, TH, RU	230 V AC, 50 Hz
AUS	240 V AC, 50 Hz
TW	110 V AC, 60 Hz

²⁾Reference power output for front, center and surround. Depending on the sound field settings and the source, there may be no sound output.

³⁾Measured under the following conditions:

Area code	Power requirements
KR, TH	220 V AC, 50 Hz

Frequency response

Analog 10 Hz – 70 kHz
+0.5/-2 dB (with sound field and tone bypassed)

Inputs

Analog Sensitivity: 800 mV/
50 kohms
S/N⁴⁾: 96 dB
(A, 800 mV⁵⁾)

Digital (Coaxial) Impedance: 75 ohms
S/N: 100 dB
(A, 20 kHz LPF)

Digital (Optical) S/N: 100 dB
(A, 20 kHz LPF)

Outputs (Analog)

AUDIO OUT Voltage: 800 mV/
10 kohms

SUB WOOFER Voltage: 2 V/1 kohm

Tone

Gain levels ±6 dB, 1 dB step

⁴⁾INPUT SHORT (with sound field and tone bypassed).

⁵⁾Weighted network, input level.

— Continued on next page —

MULTI CHANNEL AV RECEIVER

9-887-233-03
2007H16-1
© 2007.08

Sony Corporation
Home Audio Division
Published by Sony Techno Create Corporation

SONY®

STR-DE400

Ver. 1.1

FM tuner section

Tuning range	87.5 - 108.0 MHz
Intermediate frequency	10.7 MHz
Useable sensitivity	11.2 dBf, 1 μ V/75 ohms
S/N	
Mono/Stereo	76 dB/70 dB
Harmonic distortion at 1 kHz	
Mono/Stereo	0.3%/0.5%
Separation	45 dB at 1 kHz
Frequency response	30 Hz – 15 kHz, +0.5/-2 dB

AM tuner section

Tuning range	
Area code	Tuning scale
	10 kHz step 9 kHz step
AEP, UK, AUS, TW, KR, TH, RU	– 531 – 1,602 kHz

Intermediate frequency	450 kHz
Usable sensitivity	50 dB μ m

Video section

Inputs/Outputs	
Video:	1 V _{p-p} /75 ohms
COMPONENT VIDEO:	
Y:	1 V _{p-p} /75 ohms
P _B /C _B /B-Y:	0.7 V _{p-p} / 75 ohms
P _R /C _R /R-Y:	0.7 V _{p-p} / 75 ohms
80 MHz HD Pass Through	

General

Power requirements	
Area code	Power requirements
AEP, UK, RU	230 V AC, 50/60 Hz
AUS	240 V AC, 50 Hz
KR, TH	220 – 230 V AC, 50/60 Hz
TW	110 V AC, 60 Hz

Power consumption

Area code	Power consumption
AEP, UK, AUS, KR, RU	190 W
TH	170 W
TW	400 W

Power consumption (during standby mode)
0.2 W

Dimensions (w/h/d) (Approx.)
430 × 145 × 300 mm
including projecting parts
and controls

Mass (Approx.) 7.8 kg

Design and specifications are subject to
change without notice.

• Abbreviation

AUS	: Australian model
KR	: Korean model
RU	: Russian model
TH	: Thai model
TW	: Taiwan model

Notes on chip component replacement

- Never reuse a disconnected chip component.
- Notice that the minus side of a tantalum capacitor may be damaged by heat.

UNLEADED SOLDER

Boards requiring use of unleaded solder are printed with the lead-free mark (LF) indicating the solder contains no lead. (Caution: Some printed circuit boards may not come printed with the lead free mark due to their particular size)

LEAD FREE MARK

Unleaded solder has the following characteristics.

- Unleaded solder melts at a temperature about 40 °C higher than ordinary solder.
Ordinary soldering irons can be used but the iron tip has to be applied to the solder joint for a slightly longer time.
Soldering irons using a temperature regulator should be set to about 350 °C.
Caution: The printed pattern (copper foil) may peel away if the heated tip is applied for too long, so be careful!
- Strong viscosity
Unleaded solder is more viscous (sticky, less prone to flow) than ordinary solder so use caution not to let solder bridges occur such as on IC pins, etc.
- Usable with ordinary solder
It is best to use only unleaded solder but unleaded solder may also be added to ordinary solder.

SAFETY-RELATED COMPONENT WARNING!!

COMPONENTS IDENTIFIED BY MARK \triangle OR DOTTED LINE WITH MARK \triangle ON THE SCHEMATIC DIAGRAMS AND IN THE PARTS LIST ARE CRITICAL TO SAFE OPERATION. REPLACE THESE COMPONENTS WITH SONY PARTS WHOSE PART NUMBERS APPEAR AS SHOWN IN THIS MANUAL OR IN SUPPLEMENTS PUBLISHED BY SONY.

About area codes

The area code of the receiver you purchased is shown on the lower right portion of the rear panel (see the illustration below).

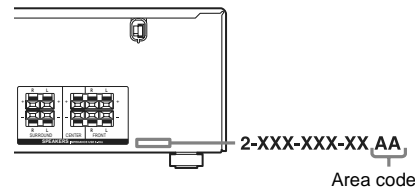

Any differences in operation, according to the area code, are clearly indicated in the text, for example, "Models of area code AA only".

MODEL IDENTIFICATION

– Rear Panel –

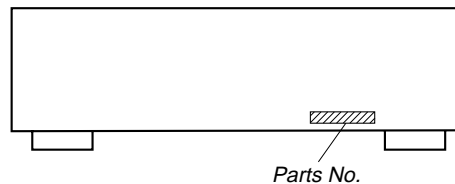

Model	Part No.
AEP, UK models	2-662-058-0□
AUS model	2-662-058-1□
Taiwan model	2-662-058-2□
Korean model	2-662-058-3□
Thai model	2-662-058-4□
Russian model	2-662-058-5□

TABLE OF CONTENTS

1. GENERAL 4

2. TEST MODE 10

3. DIAGRAMS

3-1. Block Diagram – MAIN Section – 14

3-2. Block Diagram – DISPLAY/POWER Section – 15

3-3. Printed Wiring Board – DIGITAL Board (Side A) – 16

3-4. Printed Wiring Board – DIGITAL Board (Side B) – 17

3-5. Schematic Diagram – DIGITAL Board (1/3) – 18

3-6. Schematic Diagram – DIGITAL Board (2/3) – 19

3-7. Schematic Diagram – DIGITAL Board (3/3) – 20

3-8. Printed Wiring Board – MAIN Board – 21

3-9. Schematic Diagram – MAIN Board (1/3) – 22

3-10. Schematic Diagram – MAIN Board (2/3),
HEADPHONE Board – 23

3-11. Schematic Diagram – MAIN Board (3/3),
ADCC Board, STANDBY Board – 24

3-12. Printed Wiring Boards
– ADCC Board, HEADPHONE Board – 25

3-13. Printed Wiring Board – STANDBY Board – 26

3-14. Printed Wiring Board – DISPLAY Board – 27

3-15. Printed Wiring Boards
– TUNING Board, POWER Board – 28

3-16. Schematic Diagram – DISPLAY Board,
TUNING Board, POWER Board – 29

3-17. Printed Wiring Board – VIDEO Board – 30

3-18. Schematic Diagram – VIDEO Board – 31

4. EXPLODED VIEWS

4-1. Front Panel Section 39

4-2. Chassis Section 40

5. ELECTRICAL PARTS LIST 41

SERVICING NOTE

Note on replacement POWER AMPLIFIER IC

There are two kinds of sets by POWER AMPLIFIER IC (IC501, IC601, IC701: on MAIN board) used with this model.

Type1 : 6-600-450-01 IC STK350-530-E
Type2 : 6-710-828-01 IC STK350-530T-E

As for the set of type1 and type2, the parts on the Main board in the table below are different.

When repairing, please confirm the type name printed on IC at the beginning and use the parts corresponded to the table below.

Ref. No.	Type1 : STK350-530-E					Type2 : STK350-530T-E					Wiring Board Location
C504	1-102-233-00	CERAMIC	33PF	10%	500V	1-101-810-00	CERAMIC	100PF	5%	500V	D-6
C554	1-102-233-00	CERAMIC	33PF	10%	500V	1-101-810-00	CERAMIC	100PF	5%	500V	D-7
C604	1-102-233-00	CERAMIC	33PF	10%	500V	1-101-810-00	CERAMIC	100PF	5%	500V	D-7
C654	1-102-233-00	CERAMIC	33PF	10%	500V	1-101-810-00	CERAMIC	100PF	5%	500V	D-8
C704	1-102-233-00	CERAMIC	33PF	10%	500V	1-101-810-00	CERAMIC	100PF	5%	500V	F-3
IC501	6-600-450-01	IC STK350-530-E				6-710-828-01	IC STK350-530T-E				E-6
IC601	6-600-450-01	IC STK350-530-E				6-710-828-01	IC STK350-530T-E				E-8
IC701	6-600-450-01	IC STK350-530-E				6-710-828-01	IC STK350-530T-E				F-3

SECTION 1 GENERAL

This section is extracted from instruction manual.

Front panel

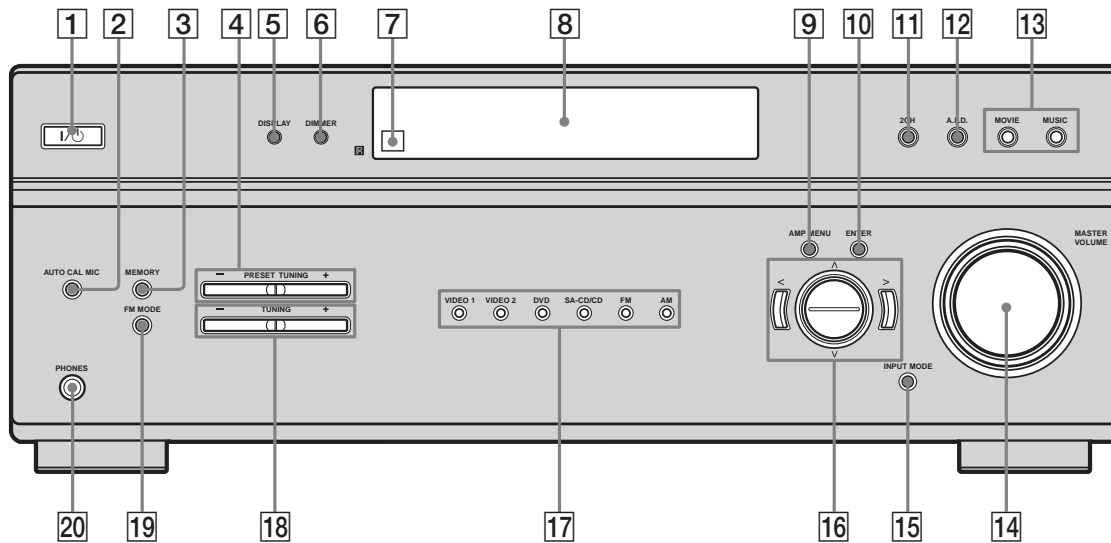

Name	Function
1 I/O	Press to turn the receiver on or off.
2 AUTO CAL MIC jack	Connects to the supplied ECM-AC2 optimizer microphone for the Auto Calibration function.
3 MEMORY	Press to store a station.
4 PRESET TUNING +/-	Press to select a preset station.
5 DISPLAY	Press to select information displayed on the display.
6 DIMMER	Press to adjust the brightness of the display.
7 Remote sensor	Receives signals from remote commander.
8 Display	The current status of the selected component or a list of selectable items appears here.
9 AMP MENU	Press to display the menu of the receiver.
10 ENTER	Press to store a station or enter the selection when selecting the settings.

Name	Function
11 2CH	Press to select 2CH STEREO mode.
12 A.F.D.	Press to select A.F.D. mode.
13 MOVIE, MUSIC	Press to select sound fields (MOVIE, MUSIC).
14 MASTER VOLUME	Turn to adjust the volume level of all speakers at the same time.
15 INPUT MODE	Press to select the input mode when the same components are connected to both digital and analog jacks.
16 </>/^/∨	After pressing AMP MENU (9), press < or > and ^ or ∨ to select the settings.
17 Input buttons	Press one of the button to select the component you want to use.
18 TUNING +/-	Press to scan a station.
19 FM MODE	Press to select FM monaural or stereo reception.
20 PHONES jack	Connects to a headphone.

About the indicators on the display

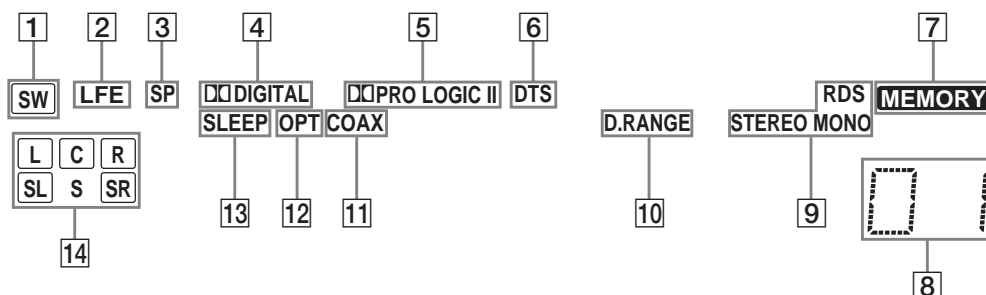

Name	Function
1 SW	Lights up when sub woofer selection is set to "YES" and the audio signal is output from the SUB WOOFER jack.
2 LFE	Lights up when the disc being played back contains an LFE (Low Frequency Effect) channel and the LFE channel signal is actually being reproduced.
3 SP	Lights up when the receiver is turned on. This indicator does not light up if a headphone is connected to the PHONES jack.
4 DIGITAL	Lights up when Dolby Digital signals are input. Note When playing a Dolby Digital format disc, be sure that you have made digital connections and that INPUT MODE is not set to "ANALOG".
5 PRO LOGIC (II)	Lights up when the receiver applies Pro Logic processing to 2 channel signals in order to output the center and surround channel signals. "PRO LOGIC II" lights up when the Pro Logic II Movie/Music decoder is activated. However, both indicators do not light up if both the center and surround speakers are set to "NO" and "A.F.D. AUTO", "DOLBY PL", "PLII MV", or "PLII MS" is selected. Note Dolby Pro Logic and Dolby Pro Logic II decoding do not function for DTS format signals.
6 DTS	Lights up when DTS signals are input. Note When playing a DTS format disc, be sure that you have made digital connections and that INPUT MODE is not set to "ANALOG".
7 MEMORY	Lights up when a memory function, such as Preset Memory, etc., is activated.

Name	Function
8 Preset station indicators	Lights up when using the receiver to tune in radio stations you have preset. For details on presetting radio stations.
9 Tuner indicators	Lights up when using the receiver to tune in radio stations, etc. Note "RDS" appears for models of area code AEP, UK only.
10 D.RANGE	Lights up when dynamic range compression is activated.
11 COAX	Lights up when INPUT MODE is set to "AUTO" and the source signal is a digital signal being input through the COAXIAL jack, or when INPUT MODE is set to "COAX IN".
12 OPT	Lights up when INPUT MODE is set to "AUTO" and the source signal is a digital signal being input through the OPTICAL jack, or when INPUT MODE is set to "OPT IN".
13 SLEEP	Lights up when the sleep timer is activated.
14 Playback channel indicators	The letters (L, C, R, etc.) indicate the channels being played back. The boxes around the letters vary to show how the receiver downmixes the source sound (based on the speaker settings). L Front Left R Front Right C Center (monaural) SL Surround Left SR Surround Right S Surround (monaural or the surround components obtained by Pro Logic processing) Example: Recording format (Front/ Surround): 3/2.1 Output channel: When surround speaker is set to "NO". Sound Field: A.F.D. AUTO

SW

L C R
SL SR

Rear panel

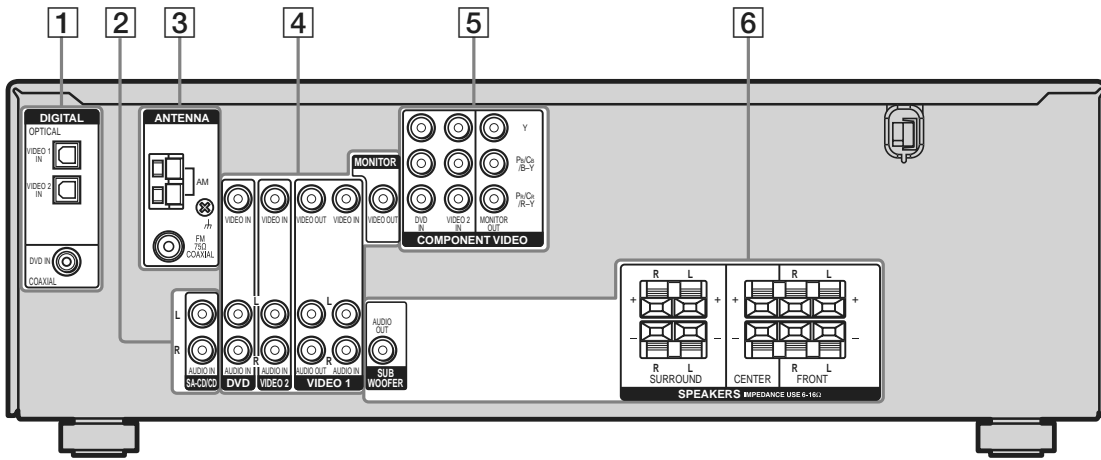

1 DIGITAL INPUT section



OPTICAL IN jack Connects to a DVD player, etc. The COAXIAL jack provides a better quality of loud sound.



COAXIAL IN jack

2 AUDIO INPUT section



White (L) AUDIO IN/OUT jack Connects to an MD deck or CD player, etc.



Red (R)

3 ANTENNA section



FM ANTENNA Connects to the FM wire antenna supplied with this receiver.



AM ANTENNA Connects to the AM loop antenna supplied with this receiver.

4 VIDEO/AUDIO INPUT/OUTPUT section



White (L) AUDIO IN/OUT jack Connects the video and audio jacks of a VCR or a DVD player.



Red (R)



Yellow VIDEO IN/OUT jack*

5 COMPONENT VIDEO INPUT/OUTPUT section



Green COMPONENT VIDEO INPUT/OUTPUT jack* Connects to a DVD player, TV, or a satellite tuner. You can enjoy high quality image.



Blue



Red

6 SPEAKER section



Connects to speakers.



Connects to sub woofer.

* You can watch the selected input image when you connect the MONITOR OUT jack to a TV monitor.

Remote commander

You can operate the receiver with the supplied remote. You can also use the remote to control the Sony audio/video components that the remote is assigned to operate.

RM-AAU006

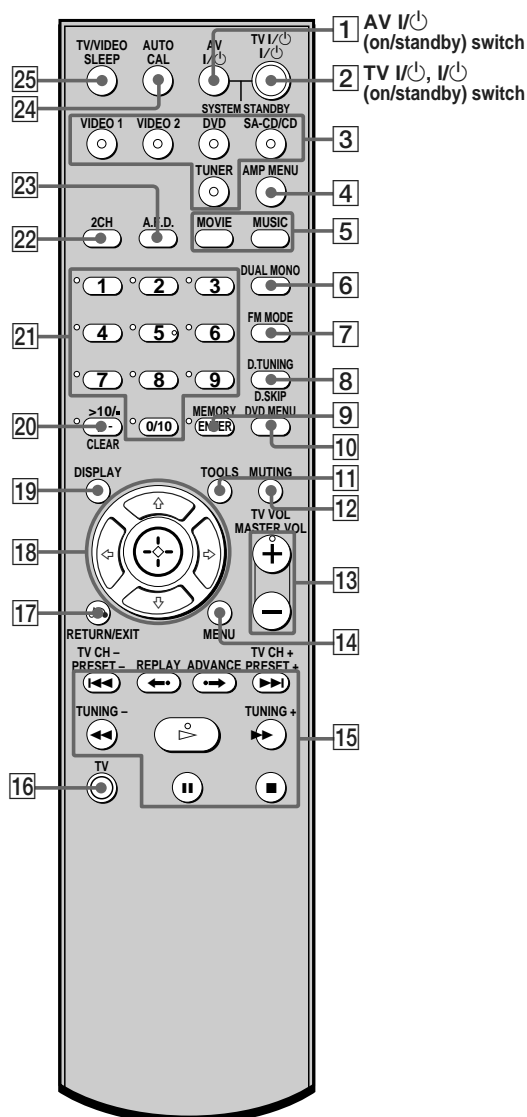

Name	Function
------	----------

1 AV I/⏻	Press to turn on or off the Sony audio/video components that the remote is assigned to operate. If you press I/⏻ (2) at the same time, it will turn off the receiver and other components (SYSTEM STANDBY). Note The function of the AV I/⏻ switch changes automatically each time you press the input buttons (3).
-----------------	---

2 TV I/⏻	Press TV I/⏻ and TV (16) at the same time to turn the TV on or off.
-----------------	--

I/⏻	Press to turn the receiver on or off. To turn off all components, press I/⏻ and AV I/⏻ (1) at the same time (SYSTEM STANDBY).
-----	---









3 Input buttons	Press one of the buttons to select the component you want to use. When you press any of the input buttons, the receiver turns on. The buttons are factory assigned to control Sony components as follows. You can change the button assignments following the steps in "Changing button assignments".
------------------------	---

Button	Assigned Sony component
VIDEO 1	VCR (VTR mode 3)
VIDEO 2	VCR (VTR mode 2)
DVD	DVD player
SA-CD/CD	Super Audio CD/CD player
TUNER	Built-in tuner

4 AMP MENU	Press to display the menu of the receiver. Then, use the control buttons to perform menu operations.
-------------------	--

5 MOVIE, MUSIC	Press to select sound fields for movie or music.
-----------------------	--

Name	Function
6 DUAL MONO	Press to select the language you want during digital broadcast.
7 FM MODE	Press to select FM monaural or stereo reception.
8 D.TUNING	Press to enter direct tuning mode.
D.SKIP	Press to skip disc of the CD player or DVD player (multi-disc changer only).
9 ENTER	Press to enter the value after selecting a channel, disc or track using the numeric buttons.
MEMORY	Press to store a station.
10 DVD MENU	Press to display the menu of the DVD player on the TV screen. Then, use the control buttons to perform menu operations.
11 TOOLS	Press to display options applicable to the entire disc (e.g. disc protection), recorder (e.g. audio settings during recording), or multiple items on a list menu (e.g. erasing multiple titles).
12 MUTING	Press to mute the sound.
13 TV VOL +^a/-	Press TV VOL +/- and TV (16) at the same time to adjust the TV volume level.
MASTER VOL +^a/-	Press to adjust the volume level of all speakers at the same time.
14 MENU	Press to display the menus of the VCR, DVD player, or satellite tuner on the TV screen. Then, use the control buttons to perform menu operations.

Name	Function
15 	Press to skip tracks of the CD player, DVD player, MD deck, or tape deck.
REPLAY  / ADVANCE 	Press to replay the previous scene or fast forward the current scene of the VCR or DVD player.
	Press to – search tracks in the forward/backward direction of the DVD player. – fast forward/rewind of the VCR, CD player, MD deck, or tape deck.
 ^{a)}	Press to start playback of the VCR, CD player, DVD player, MD deck, or tape deck.
	Press to pause playback or recording of the VCR, CD player, DVD player, MD deck, or tape deck. (Also starts recording with components in recording standby.)
	Press to stop playback of the VCR, CD player, DVD player, MD deck, or tape deck.
TV CH +/-	Press TV CH +/- and TV (16) at the same time to select preset TV channels.
PRESET +/-	Press to select – preset stations. – preset channels of the VCR or satellite tuner.
TUNING +/-	Press to scan a station.
16 TV	To activate the buttons with orange printing, press TV and the button with orange printing simultaneously.
17 RETURN/EXIT 	Press to – return to the previous menu. – exit the menu while the menu or on-screen guide of the VCR, DVD player, or satellite tuner is displayed on the TV screen.

Name	Function
18 Control buttons	After pressing AMP MENU (4), DVD MENU (10), or MENU (14), press the control button ▲ , ▼ , ◀ or ▶ to select the settings. When you press DVD MENU or MENU, press the control button to enter the selection.
19 DISPLAY	Press to <ul style="list-style-type: none"> – select information displayed on the receiver's display (for TUNER input only). – select information displayed on the TV screen of the VCR, satellite tuner, CD player, DVD player, or MD deck.
20 -/--	Press -/-- and TV (16) at the same time to select the channel entry mode, either one or two digits of the TV.
>10/•	Press to select <ul style="list-style-type: none"> – track numbers over 10 of the VCR, satellite tuner, CD player or MD deck. – channel numbers of the Digital CATV terminal.
CLEAR	Press to <ul style="list-style-type: none"> – clear a mistake when you press the incorrect numeric button. – return to continuous playback, etc. of the satellite tuner or DVD player.
21 Numeric buttons (number 5^a)	Press to <ul style="list-style-type: none"> – preset/tune to preset stations. – select track numbers of the CD player, DVD player or MD deck. Press 0/10 to select track number 10. – select channel numbers of the VCR or satellite tuner. Press the numeric buttons and TV (16) at the same time to select the TV channels.
22 2CH	Press to select 2CH STEREO mode.
23 A.F.D.	Press to select A.F.D. mode.
24 AUTO CAL	Press to activate the Auto Calibration function.

Name	Function
25 TV/VIDEO	Press TV/VIDEO and TV (16) at the same time to select the input signal (TV input or video input).
SLEEP	Press to activate the Sleep Timer function and the duration which the receiver turns off automatically.

a) The number 5, MASTER VOL +, TV VOL +, and **▷** buttons have tactile dots. Use the tactile dots as references when operating the receiver.

Notes

Some functions explained in this section may not work depending on the model.

The above explanation is intended to serve as an example only. Therefore, depending on the component, the above operation may not be possible or may operate differently than described.

SECTION 2 TEST MODE

FACTORY PRESET MODE

All preset contents are reset to the default setting.

Procedure:

1. While depressing the **PRESET TUNING -** and the **DIMMER** buttons simultaneously, press the power **I/⏻** button to turn on the main power.
2. The message "FACTORY" appears and the present contents are reset to the default values.

AM CHANNEL STEP 9 kHz/10 kHz SELECTION MODE

Either the 9 kHz step or 10 kHz step can be selected for the AM channel step.

Procedure:

1. Set the FUNCTION to AM. Turn off the main power.
2. While depressing the **TUNING +** button, press the power **I/⏻** button to turn on the main power.
3. Either the message "9 k STEP" or "10 k STEP" appears. Select the desired step.

FLUORESCENT INDICATOR TUBE TEST MODE

All fluorescent segments are tested. When this test is activated, all segments turn on at the same time, then each segment turns on one after another.

Procedure:

1. While depressing the **PRESET TUNING -** and the **AM** buttons simultaneously, press the power **I/⏻** button to turn on the main power.
2. All segments turn on.

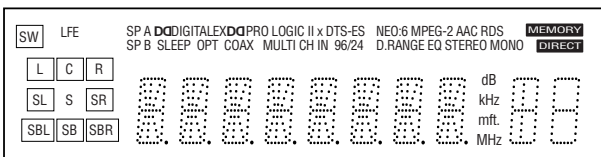

3. Press either of the **VIDEO1** or **VIDEO2** or **DVD** or **SA-CD/CD** or **FM** or **AM** button.

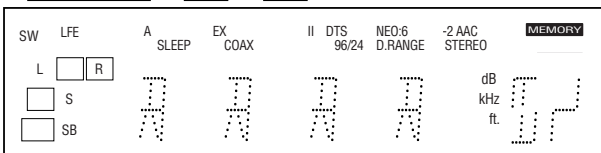

4. Press either of the **VIDEO1** or **VIDEO2** or **DVD** or **SA-CD/CD** or **FM** or **AM** button once again.

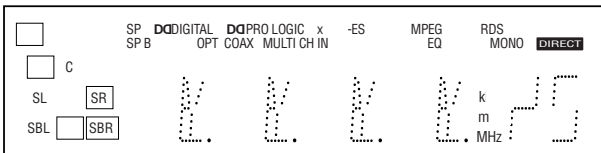

5. Press either of the **VIDEO1** or **VIDEO2** or **DVD** or **SA-CD/CD** or **FM** or **AM** button once again. All segments turn off.

SOUND FIELD CLEAR MODE

The preset sound field is cleared when this mode is activated. Use this mode before returning the product to clients upon completion of repair.

Procedure:

1. While depressing the **2CH** button, press the power **I/⏻** button to turn on the main power.
2. The message "SF. CLR." appears and initialization is performed.

SOFTWARE VERSION DISPLAY MODE

The software version is displayed.

Procedure:

1. While depressing the **PRESET TUNING -** and the **<** buttons simultaneously, press the power **I/⏻** button to turn on the main power.
2. The model name, destination and the software version are displayed.

KEY CHECK MODE

Button check

Procedure:

1. While depressing the **<** and the **A.F.D.** buttons simultaneously, press the power **I/⏻** button to turn on the main power. "REST 25" appears.
2. Every pressing of any button other than **I/⏻** counts down the buttons. The buttons which are already counted once are not counted again.
3. When all buttons are pressed "REST 00" appears.

SHIPMENT MODE

All preset contents are reset to the default setting.

Procedure:

1. While depressing the **AM** and the **A.F.D.** buttons simultaneously, press the power **I/⏻** button to turn on the main power.
2. "CLEARING" → "CLEARED" appears and switch off the set.

PROTECTOR

Procedure:

1. While depressing the **PRESET TUNING -** and the **2CH** buttons simultaneously, press the power **I/⏻** button to turn on the main power.
2. "PROT. EVER" appears and switch off the set.

DECODE AUTO ALL

Procedure:

1. While depressing the **PRESET TUNING -** and the **∧** buttons simultaneously, press the power **I/⏻** button to turn on the main power.
2. "DEC. TEST" appears and switch off the set.

SWAP ALL MODE

Procedure:

1. While depressing the **PRESET TUNING -** and the **A.F.D.** buttons simultaneously, press the power **I/O** button to turn on the main power.
2. "SWP.ALL" appears. (No change while displayed.)

ADCC FACTORY TEST MODE

ADCC Factory Test mode have two stages:

1. ADCC DSP Data Line Checking
2. ADCC AUTO CAL MIC board Checking

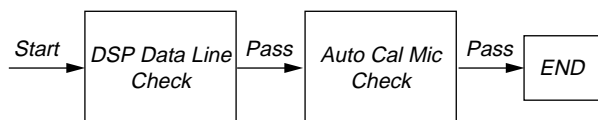

Factory Test System Setup

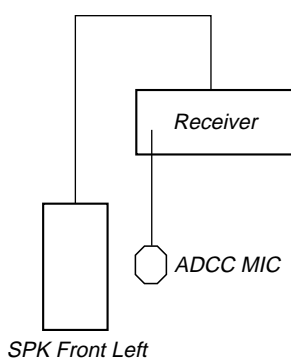

1. When power off :
Press the three buttons **<** + **DISPLAY** + **I/O** .
(If it doesn't operate, please press **DISPLAY** again afetr 2 seconds.)
Afterward, press the **DIMMER** to start DCAC factory test mode.

1. ADCC DSP Data Line Checking

After press the **DIMMER** , DCAC Factory test mode will start, below display will show:

"DCAC□□□x" x = 1, 2, 3

If there is error happen, below display will show:

"ERR□SD0x" x = 1 → D1112 or R1198 or C1523 problem

x = 2 → D1113 problem

x = 3 → D1114 problem

2. ADCC AUTO CAL MIC board Checking

Connect front left speaker of the receiver and AUTO CAL microphone. Turn **MASTER VOLUME** jog, there will be test tone sound output from front left speaker, and the display will change accordingly.



"AD□-□xxx" xxx = 0 to 255 (depends on loudness of test tone)

SECTION 3 DIAGRAMS







**THIS NOTE IS COMMON FOR PRINTED WIRING BOARDS AND SCHEMATIC DIAGRAMS.
(In addition to this, the necessary note is printed in each block.)**

For Schematic Diagrams.

Note:



- All capacitors are in μF unless otherwise noted. (p: pF)
50 WV or less are not indicated except for electrolytics and tantalums.
- All resistors are in Ω and $\frac{1}{4}W$ or less unless otherwise specified.
- % : indicates tolerance.
- Δ : internal component.
-  : nonflammable resistor.
-  : fusible resistor.
-  : panel designation.

Note: The components identified by mark Δ or dotted line with mark Δ are critical for safety.
Replace only with part number specified.

-  : B+ Line.
-  : B- Line.
- Voltages and waveforms are dc with respect to ground under no-signal (detuned) conditions.
No mark : FM
- Voltages are taken with a VOM (Input impedance 10 M Ω).
Voltage variations may be noted due to normal production tolerances.
- Waveforms are taken with an oscilloscope.
- Circled numbers refer to waveforms.
- Signal path.
 -  : FM
 -  : ANALOG
 -  : DIGITAL
 -  : VIDEO
- Abbreviation
 - AUS : Australian model
 - KR : Korean model
 - RU : Russian model
 - TH : Thai model
 - TW : Taiwan model

For Printed Wiring Boards.

Note:

-  : parts extracted from the component side.
- \circ : Through hole.
- Δ : internal component.
-  : Pattern from the side which enables seeing.

Caution:

Pattern face side: Parts on the pattern face side seen from the pattern face are indicated.
(Side B)
Parts face side: Parts on the parts face side seen from the parts face are indicated.
(Side A)

- Indication of transistor.

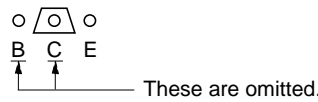
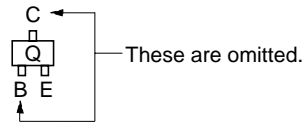

• Circuit Boards Location

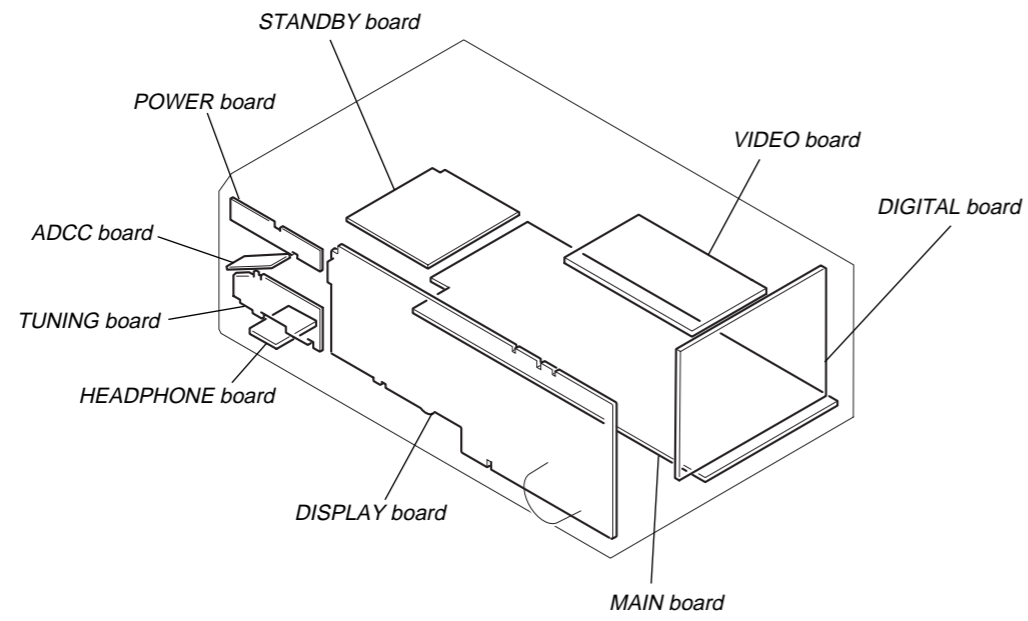

• Waveforms

– DIGITAL Board –

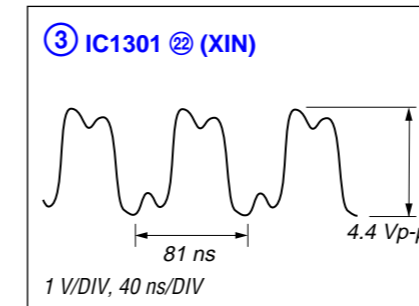
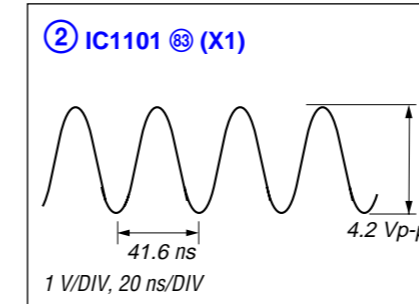
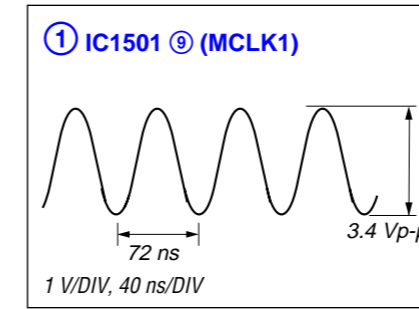

3-1. BLOCK DIAGRAM – MAIN SECTION –

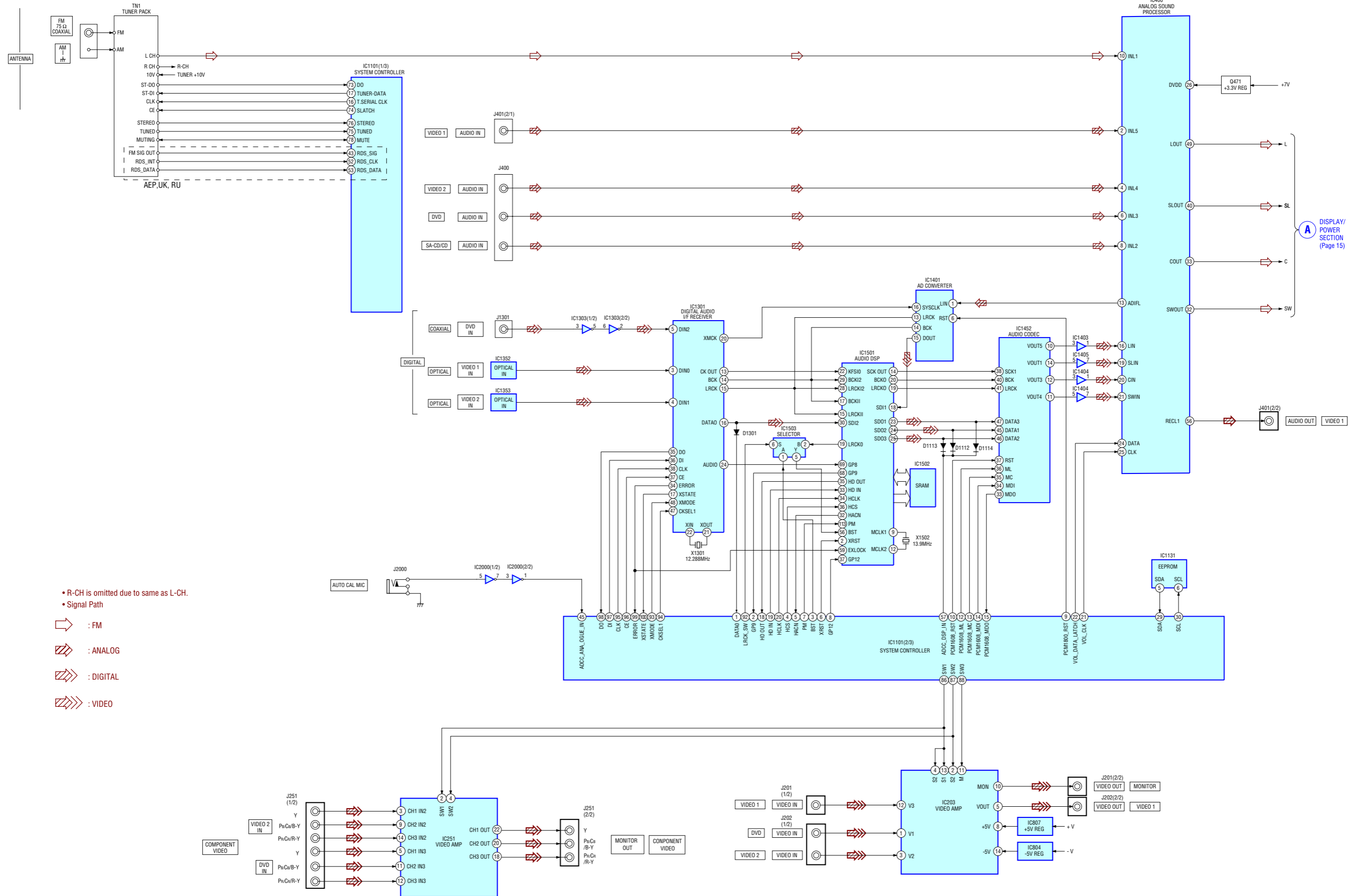

• R-CH is omitted due to same as L-CH.
 • Signal Path

- : FM
- : ANALOG
- : DIGITAL
- : VIDEO

A DISPLAY/ POWER SECTION (Page 15)

3-2. BLOCK DIAGRAM – DISPLAY/POWER SECTION –

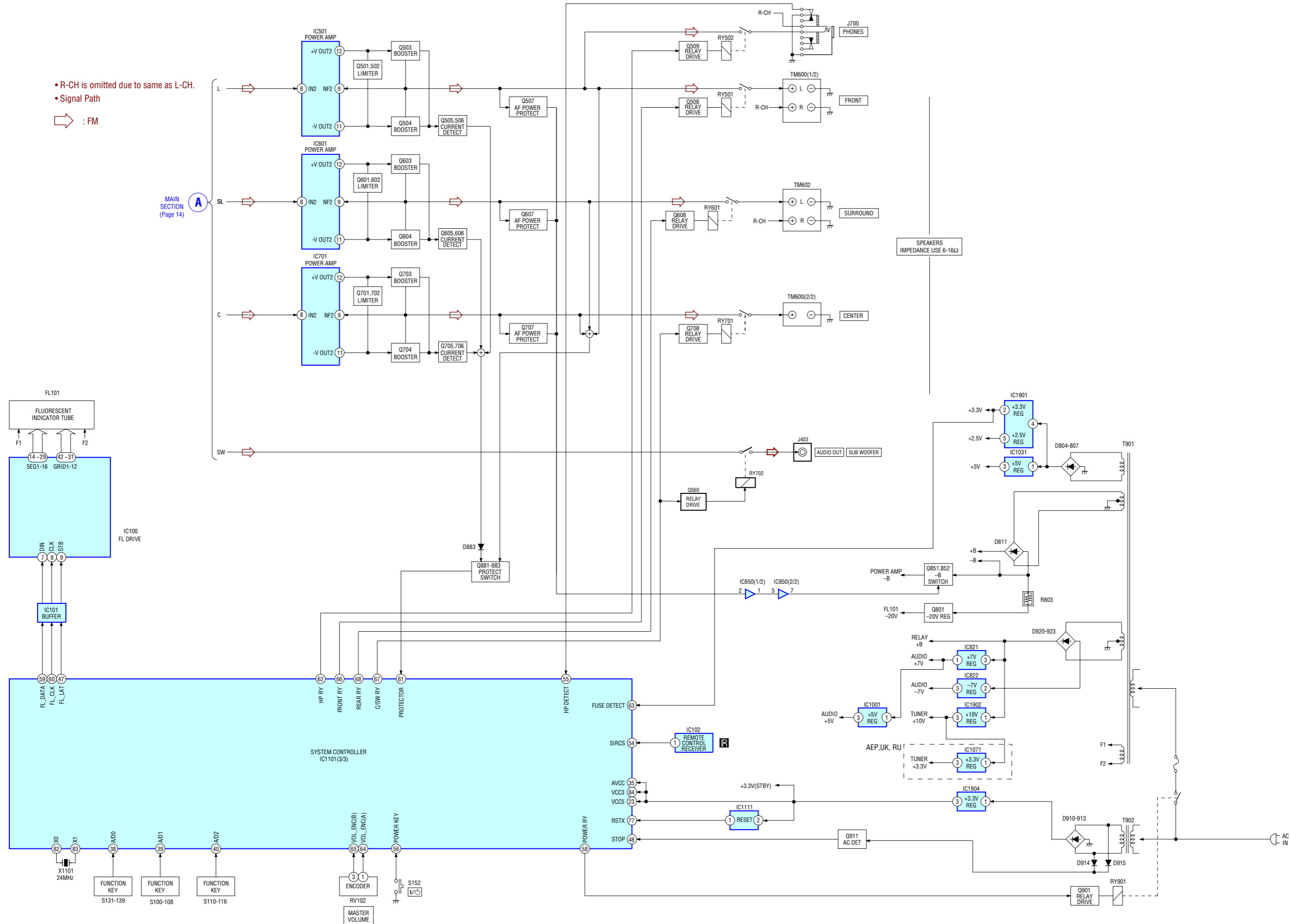

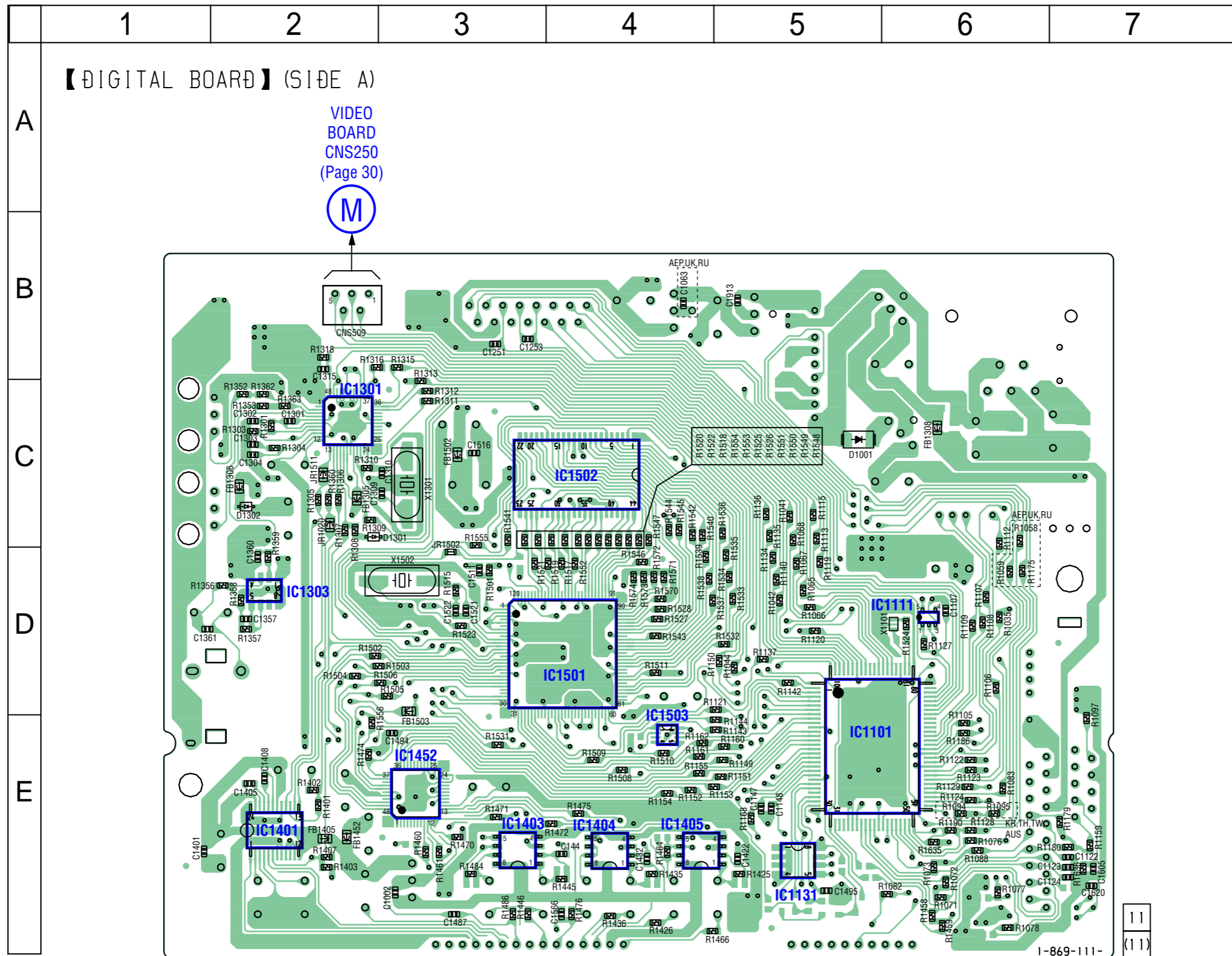

• Semiconductor Location

Ref. No.	Location
D1001	C-5
D1301	C-3
D1302	C-2
IC1101	D-5
IC1111	D-6
IC1131	E-5
IC1301	C-2
IC1303	D-2
IC1401	E-2
IC1403	E-3
IC1404	E-4
IC1405	E-4
IC1452	E-3
IC1501	D-4
IC1502	C-4
IC1503	E-4

11
(11)

I-869-111-

3-4. PRINTED WIRING BOARD – DIGITAL BOARD (SIDE B) – • See page 13 for Circuit Boards Location.  :Uses unleaded solder.

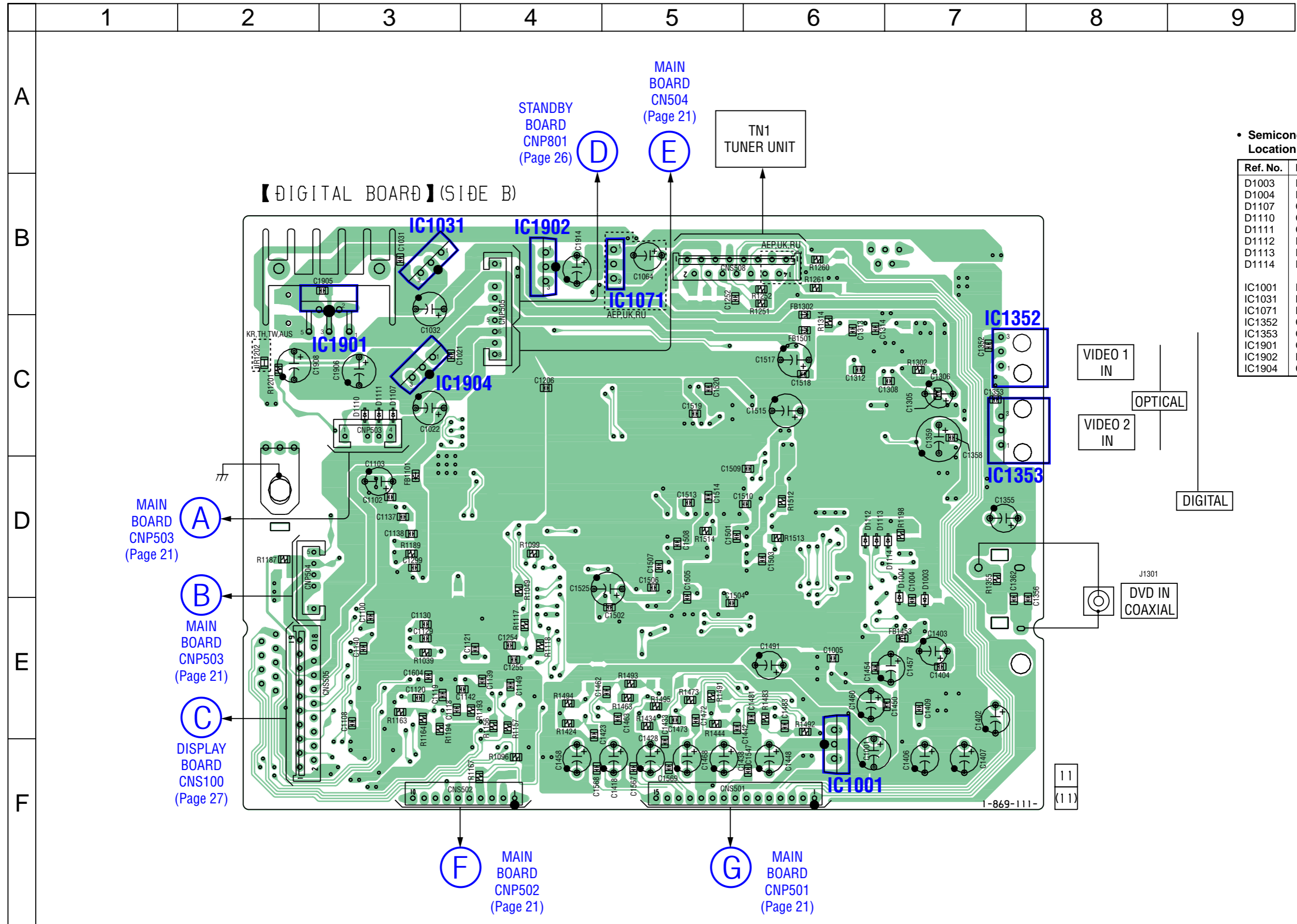

• Semiconductor Location

Ref. No.	Location
D1003	D-7
D1004	D-7
D1107	C-3
D1110	C-3
D1111	C-3
D1112	D-6
D1113	D-6
D1114	D-7
IC1001	F-6
IC1031	B-3
IC1071	B-5
IC1352	C-7
IC1353	C-7
IC1901	C-3
IC1902	B-4
IC1904	C-3

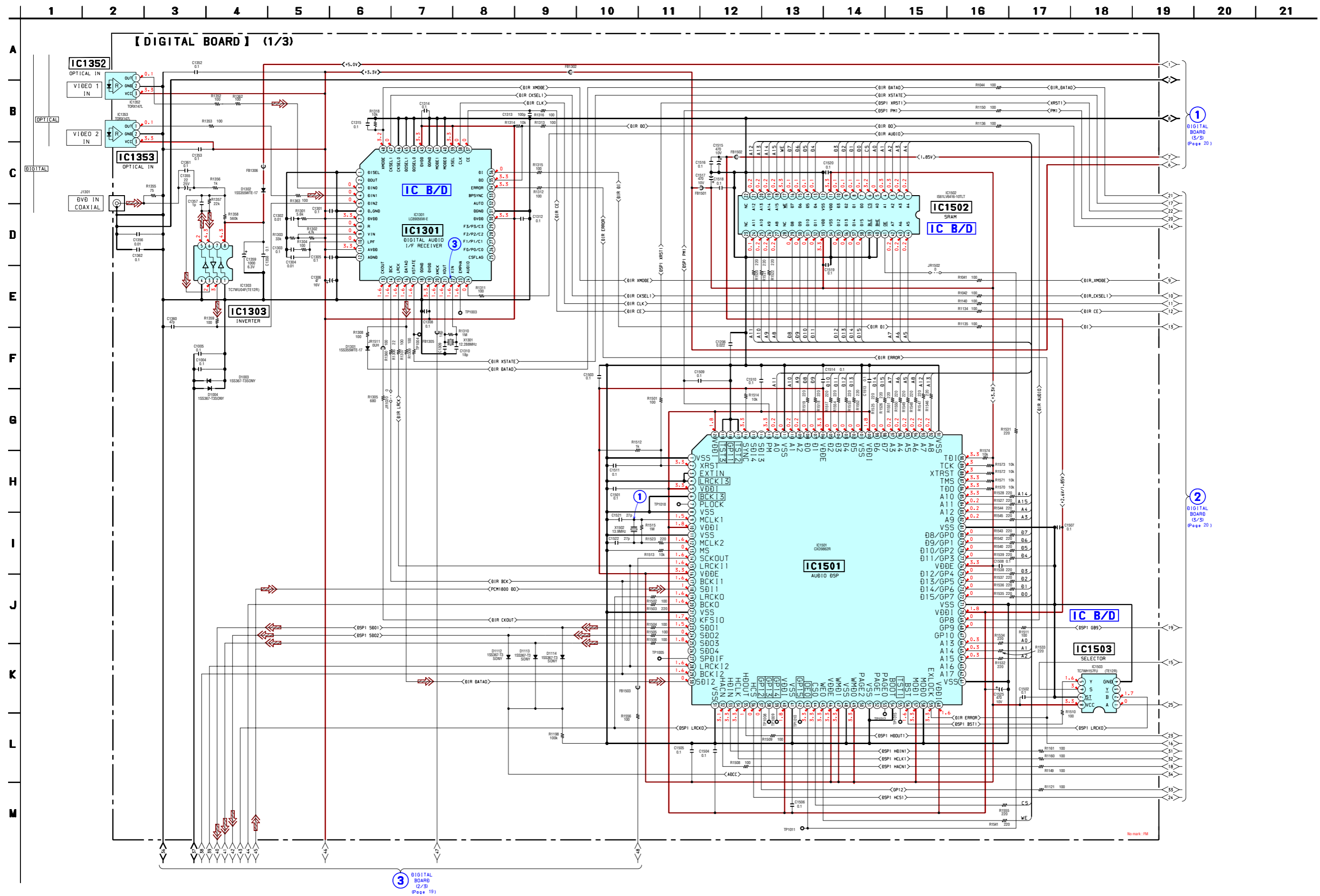

3-6. SCHEMATIC DIAGRAM – DIGITAL BOARD (2/3) – • See page 32, 33 for IC Block Diagrams.

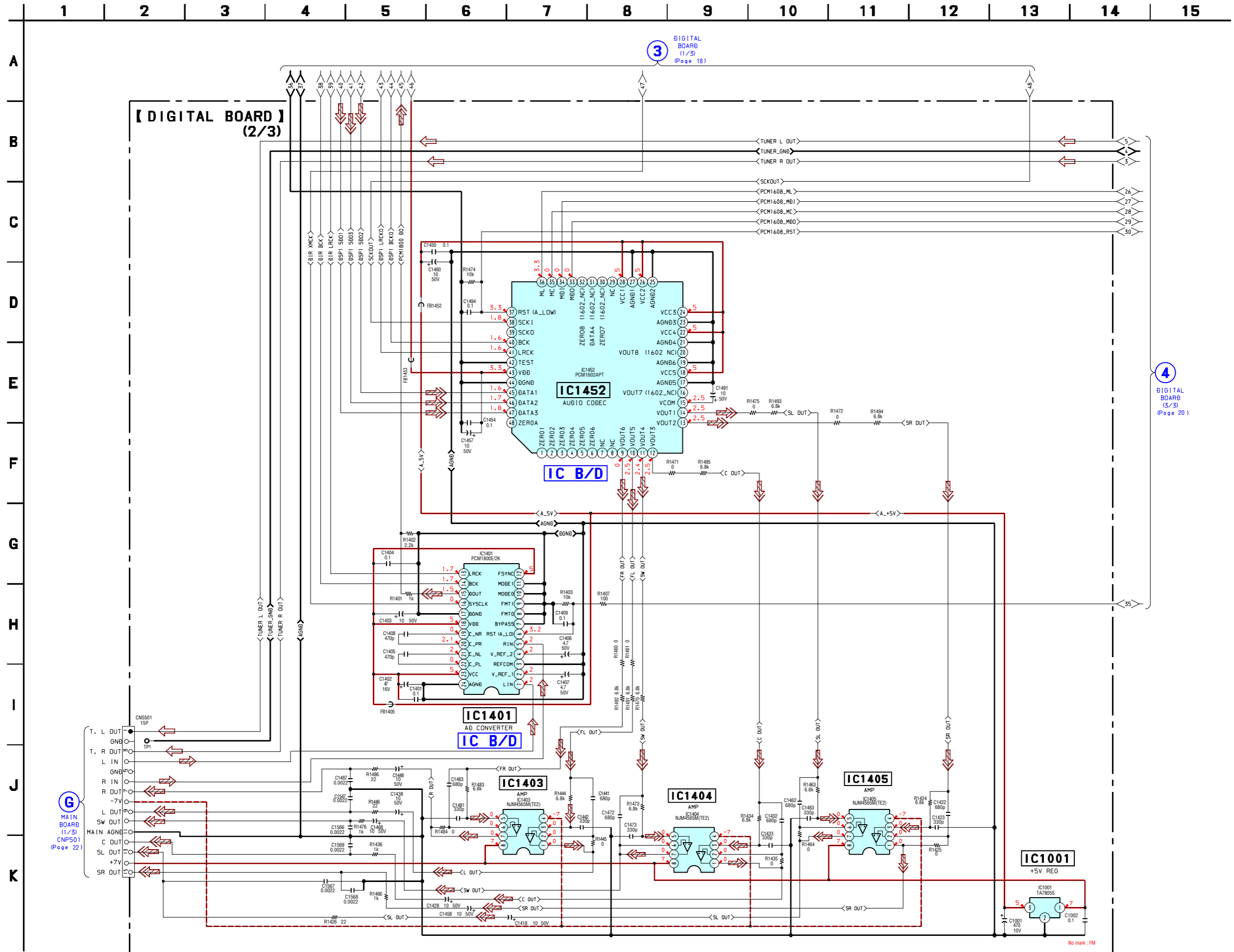

G
MAIN BOARD (1/3)
CNP501 (Page 22)

4
DIGITAL BOARD (3/3)
(Page 20)

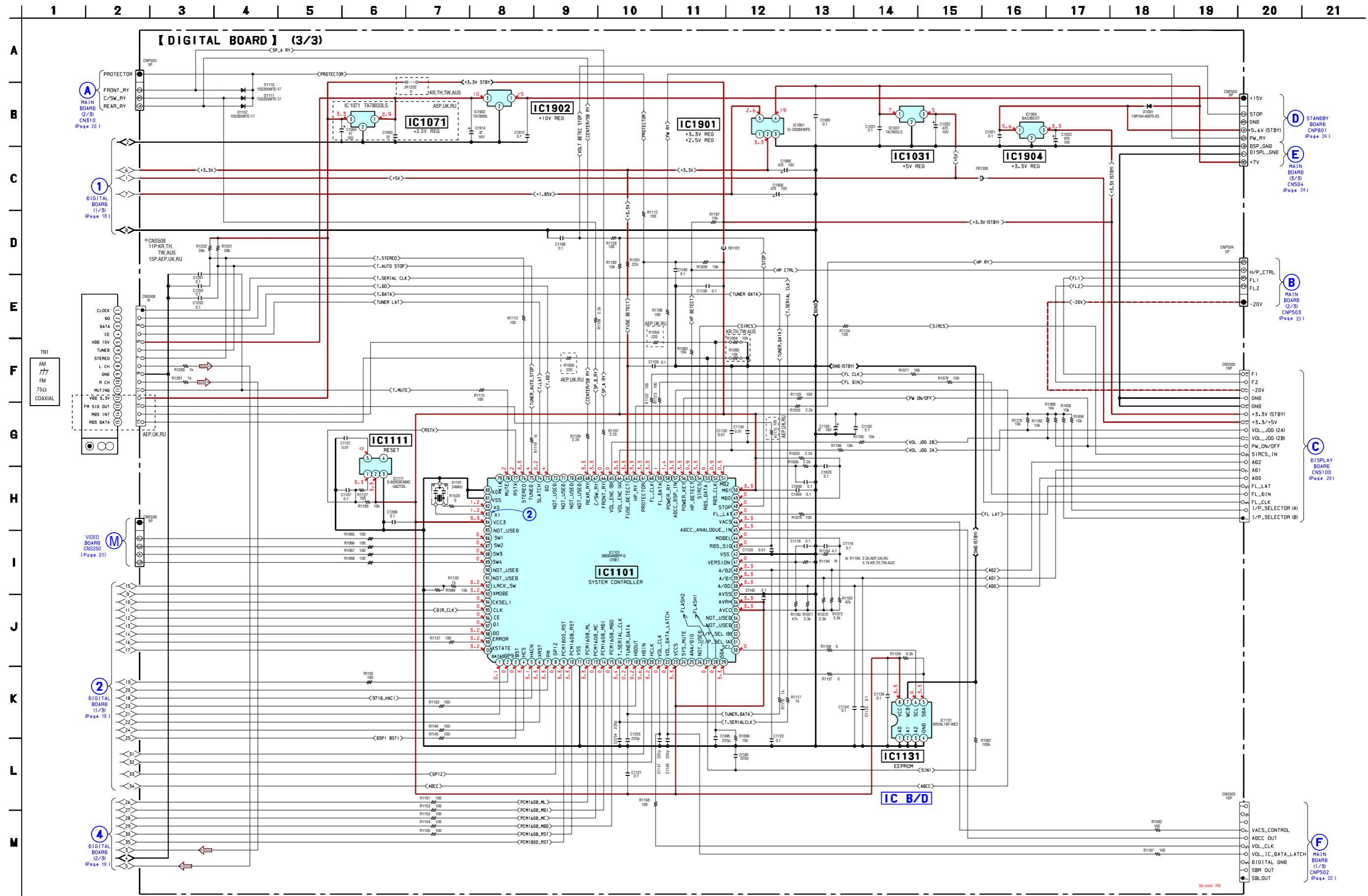

3-8. PRINTED WIRING BOARD – MAIN BOARD – • See page 13 for Circuit Boards Location.  :Uses unleaded solder.

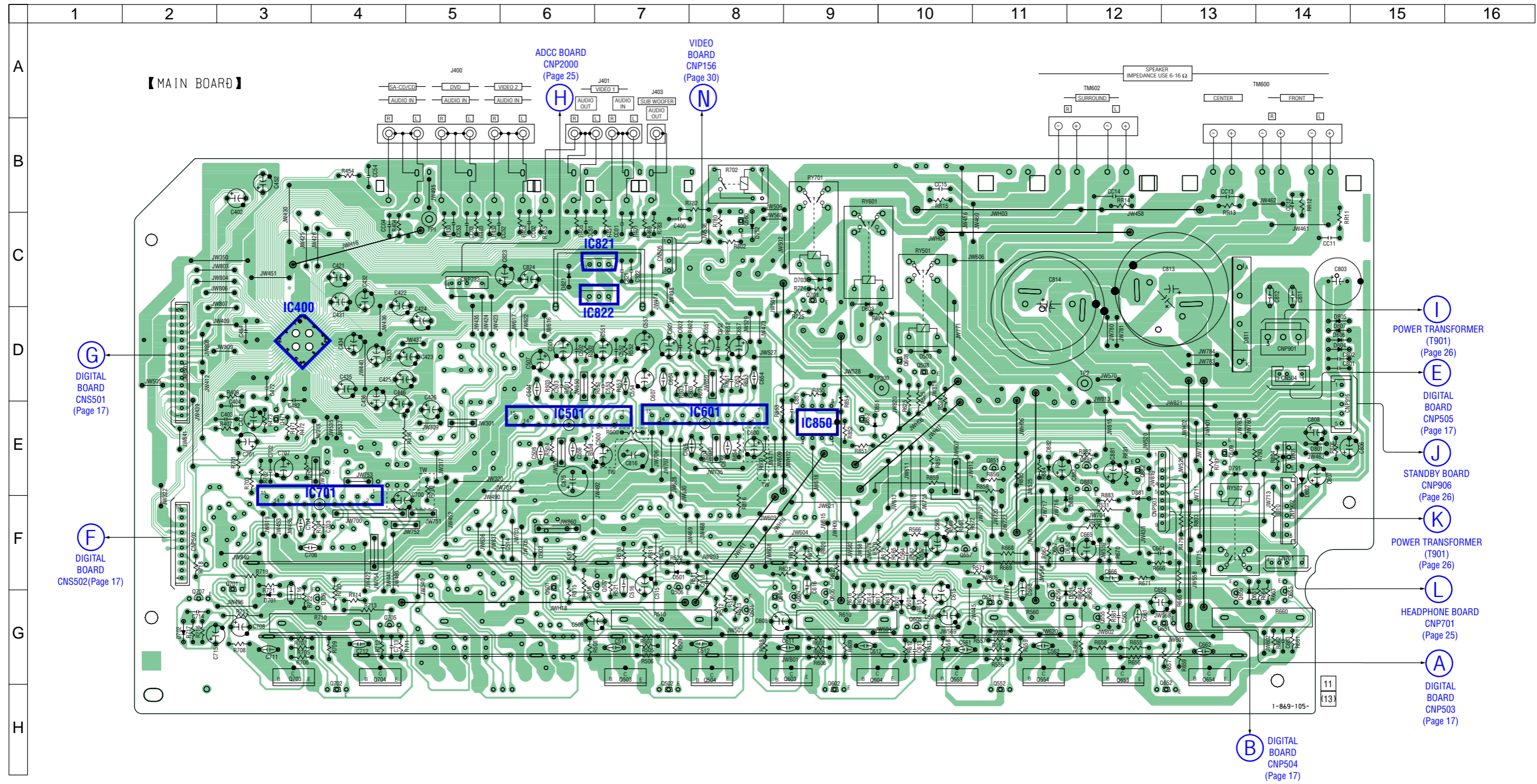

• Semiconductor Location

Ref. No.	Location	Ref. No.	Location	Ref. No.	Location	Ref. No.	Location	Ref. No.	Location
D501	F-7	D804	D-14	IC850	E-9	Q556	G-11	Q702	H-4
D502	F-6	D805	D-14	Q471	E-3	Q557	F-10	Q703	G-3
D503	D-10	D806	D-14	Q501	F-6	Q560	C-8	Q704	G-4
D551	G-12	D807	D-14	Q502	H-7	Q601	G-8	Q705	G-4
D552	F-10	D811	D-13	Q503	G-7	Q602	H-9	Q706	G-4
D601	G-10	D821	C-6	Q504	G-8	Q605	G-10	Q707	G-2
D602	G-10	D851	E-9	Q505	G-8	Q606	G-9	Q708	C-9
D603	C-9	D881	F-12	Q506	G-7	Q607	G-9	Q801	E-14
D651	G-13	D882	E-11	Q507	F-7	Q608	D-10	Q851	E-11
D652	F-12	D883	F-12	Q508	D-10	Q651	G-13	Q852	E-9
D701	G-3			Q509	E-13	Q652	H-13	Q881	E-12
D702	G-2	IC400	D-3	Q551	G-11	Q653	G-12	Q882	E-12
D703	C-9	IC501	E-6	Q552	H-11	Q654	G-14	Q883	E-12
D752	C-8	IC601	E-8	Q553	G-10	Q655	G-14		
D791	E-13	IC701	E-4	Q554	G-11	Q656	G-13		
D801	E-14	IC821	C-7	Q555	G-12	Q657	F-11		
D802	E-14	IC822	C-7			Q701	F-3		

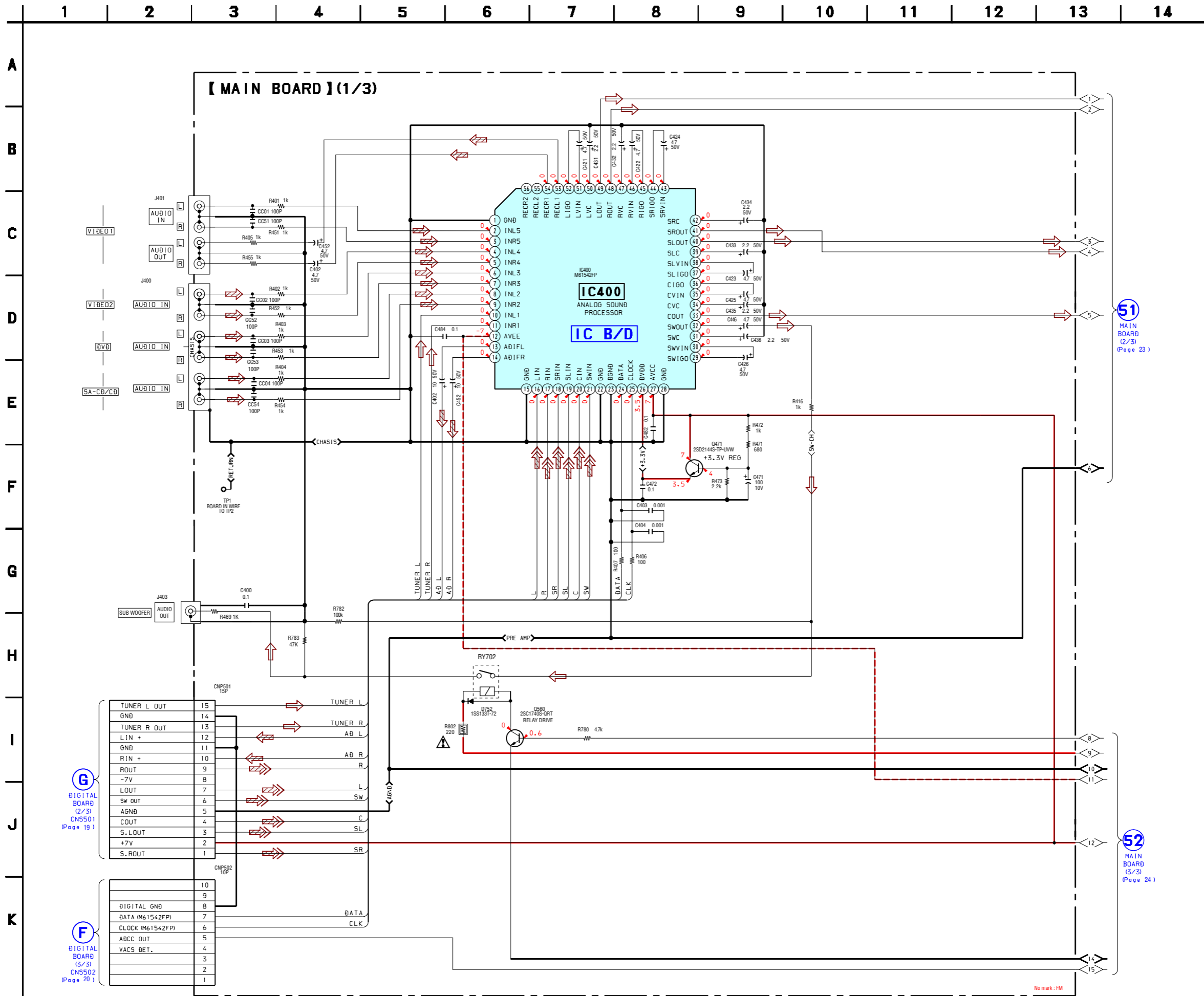

3-10. SCHEMATIC DIAGRAM – MAIN BOARD (2/3), HEADPHONE BOARD – • See page 33 for IC Block Diagrams.

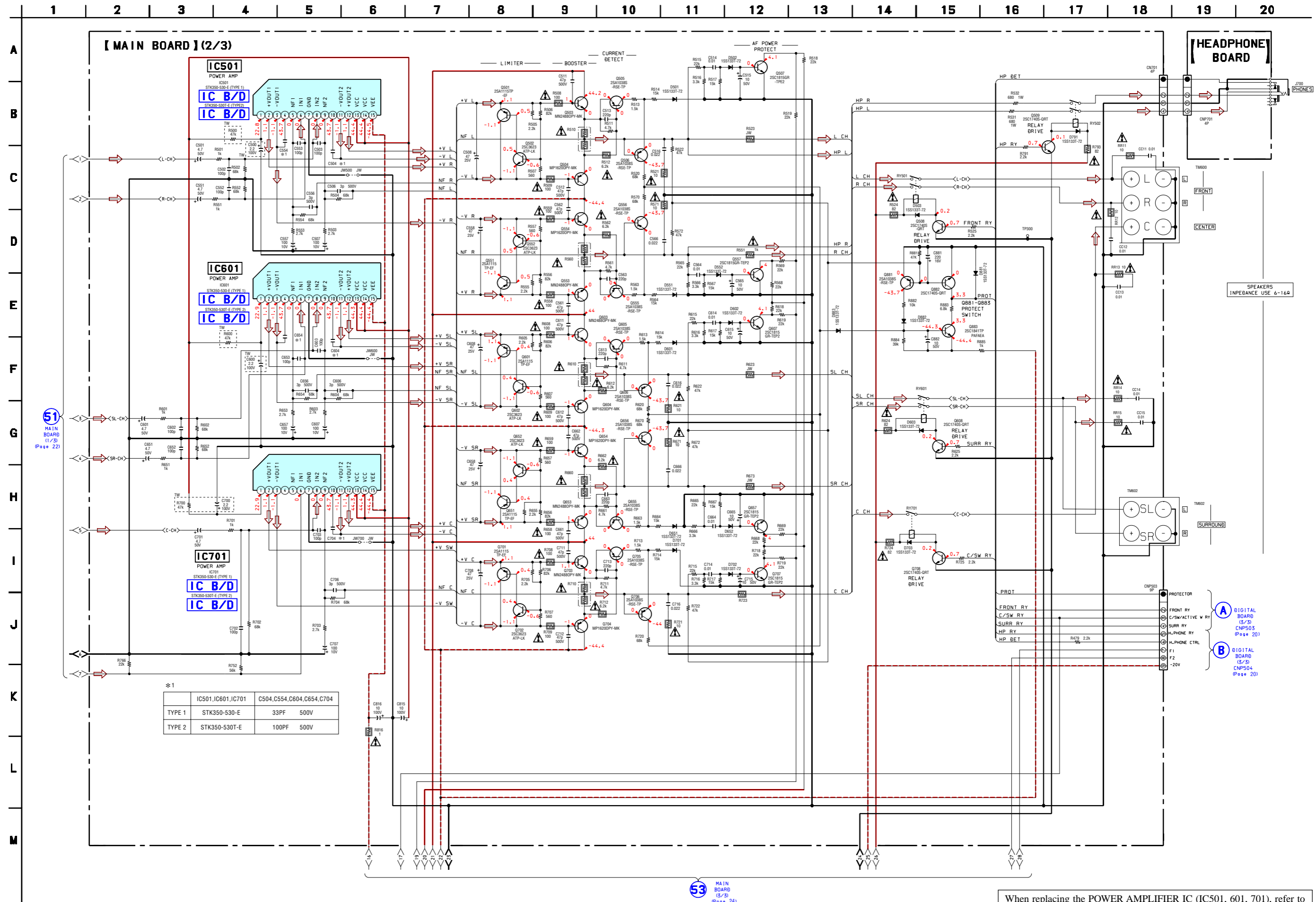

When replacing the POWER AMPLIFIER IC (IC501, 601, 701), refer to SERVICE NOTE "Note on replacement POWER AMPLIFIER IC" (page3).

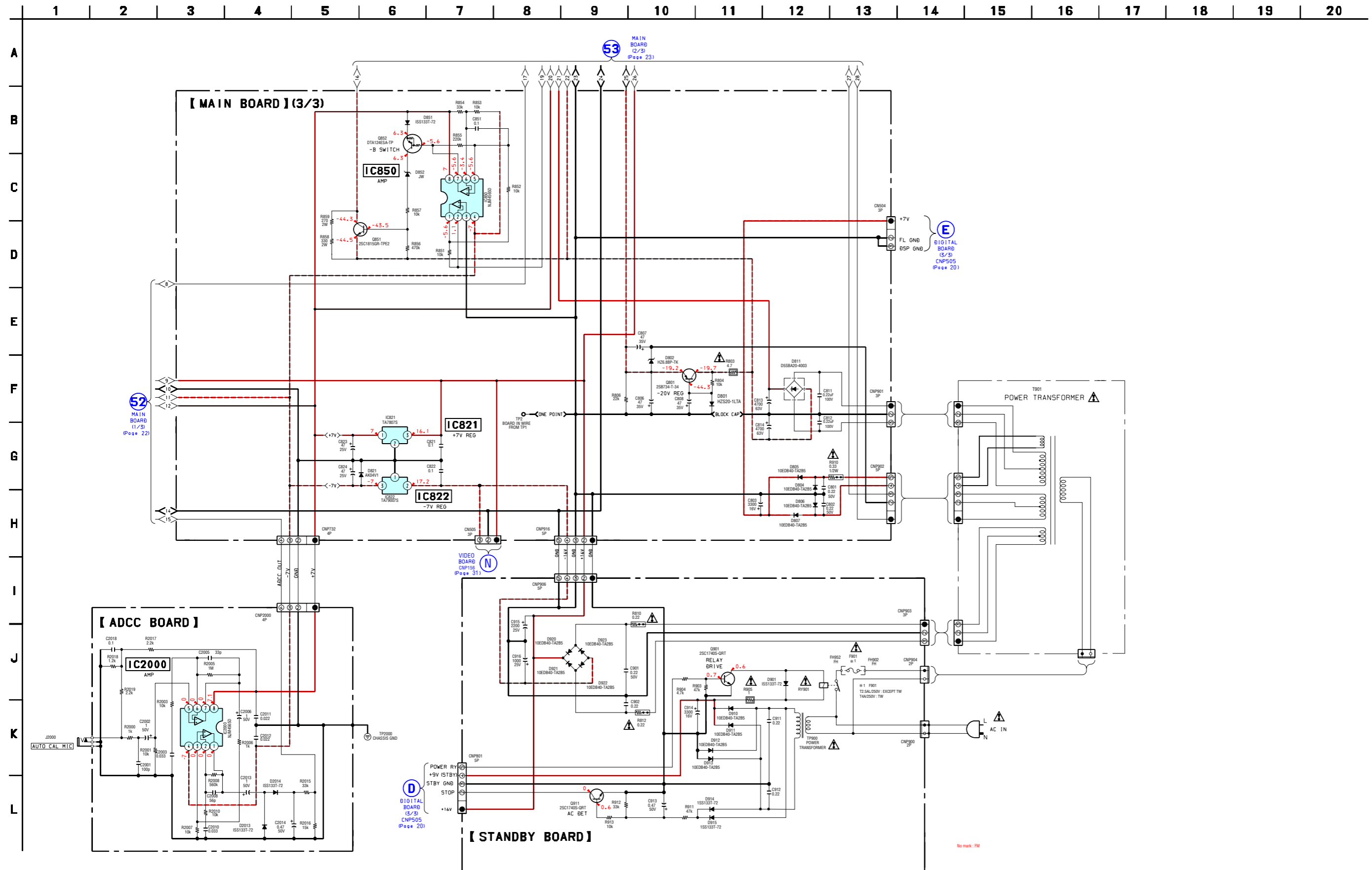

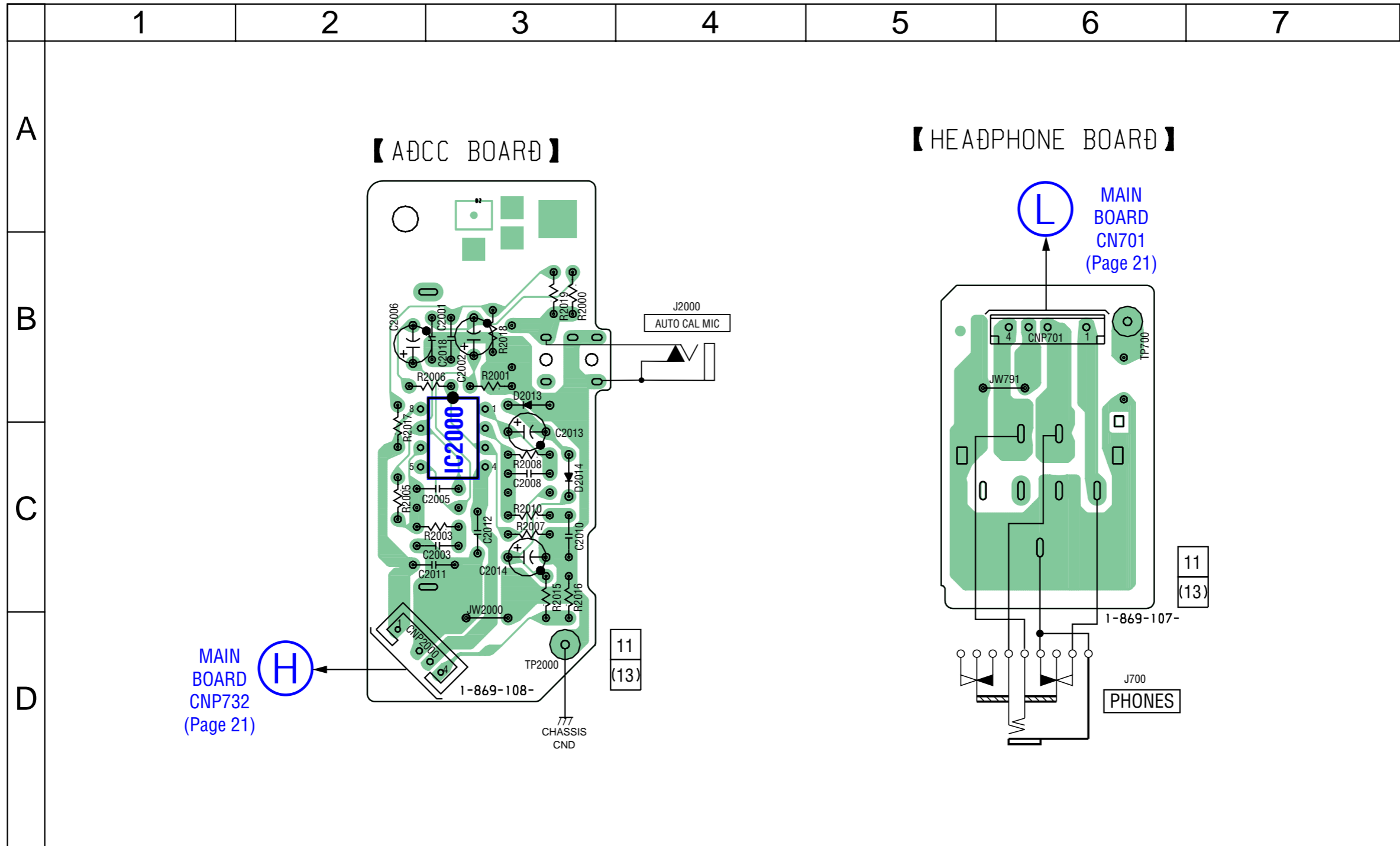

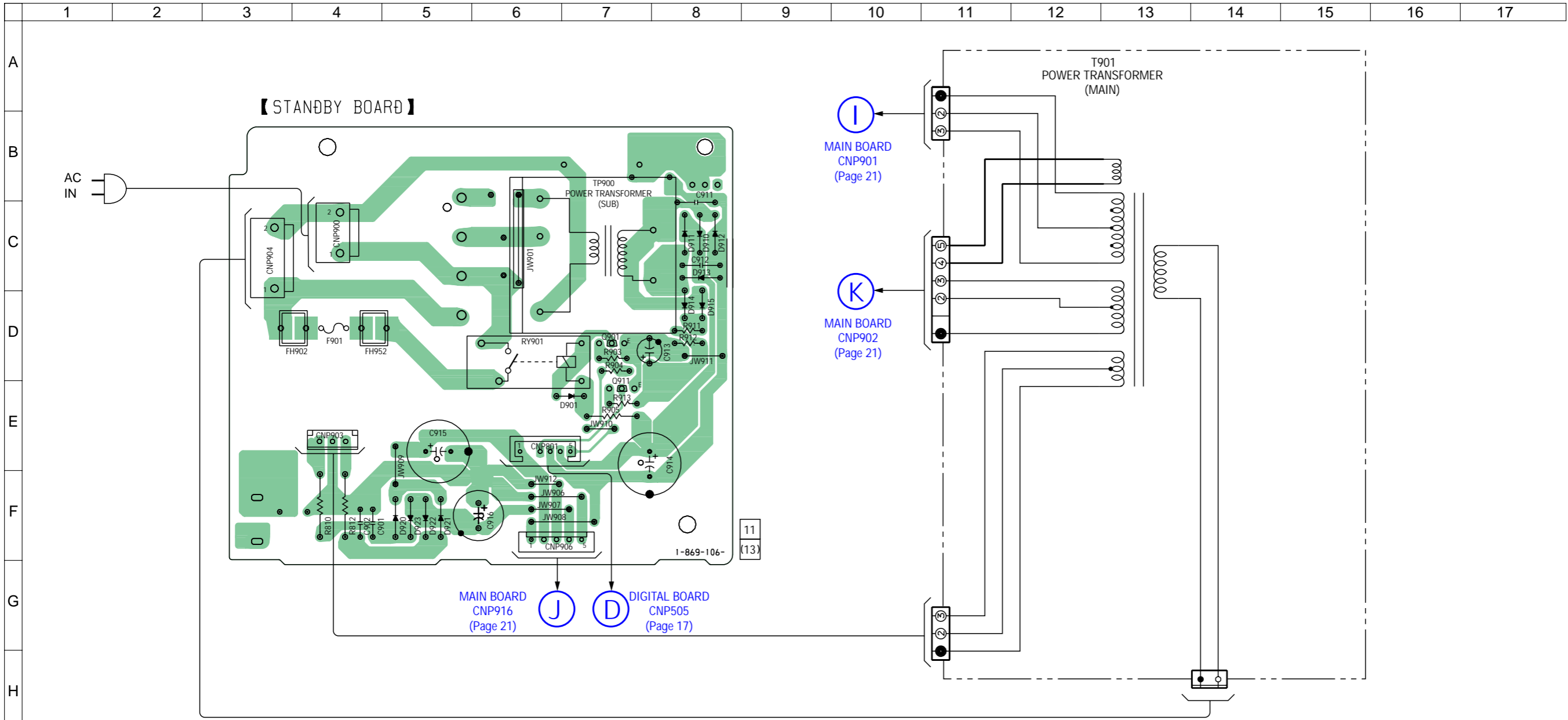

• Semiconductor Location

Ref. No.	Location
D901	E-7
D910	C-8
D911	C-8
D912	C-8
D913	C-8
D914	D-8
D915	D-8
D920	F-5
D921	F-5
D922	F-5
D923	F-5
Q901	D-7
Q911	E-7

3-14. PRINTED WIRING BOARD – DISPLAY BOARD – • See page 13 for Circuit Boards Location.  :Uses unleaded solder.

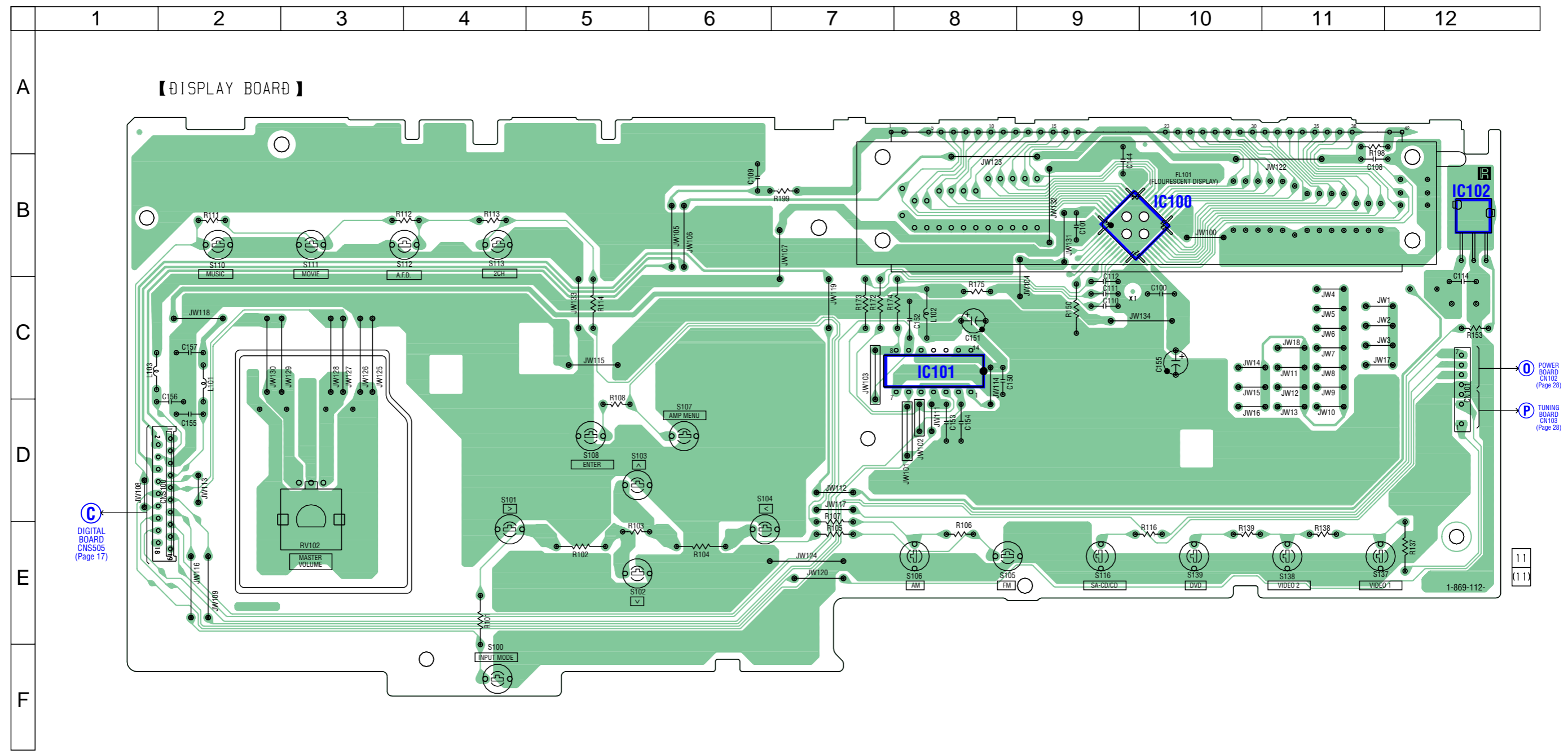

ⓐ POWER BOARD CN102 (Page 28)
ⓑ TUNING BOARD CN103 (Page 28)

11
111

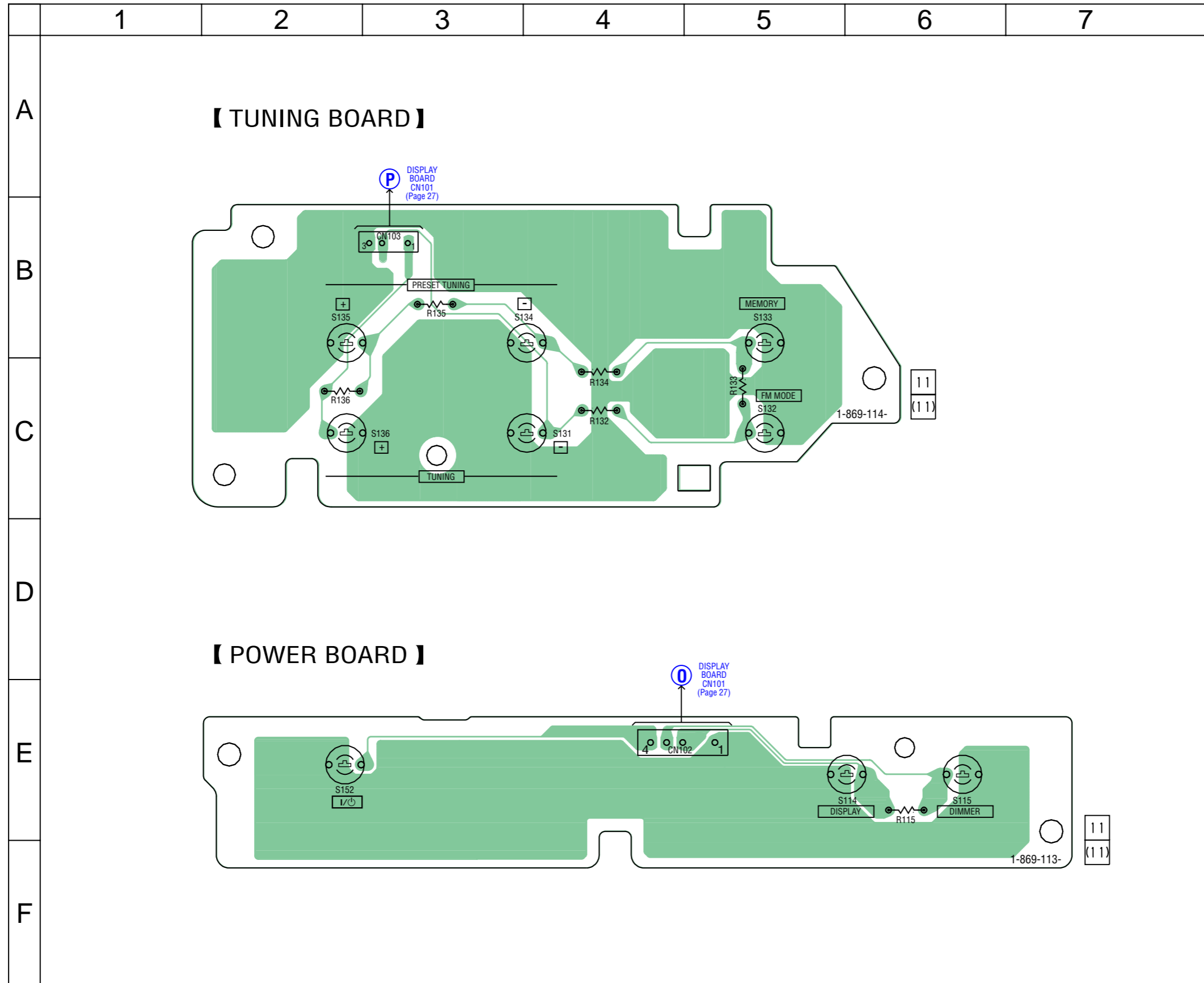

3-16. SCHEMATIC DIAGRAM – DISPLAY BOARD, TUNING BOARD, POWER BOARD – • See page 35 for IC Block Diagram.

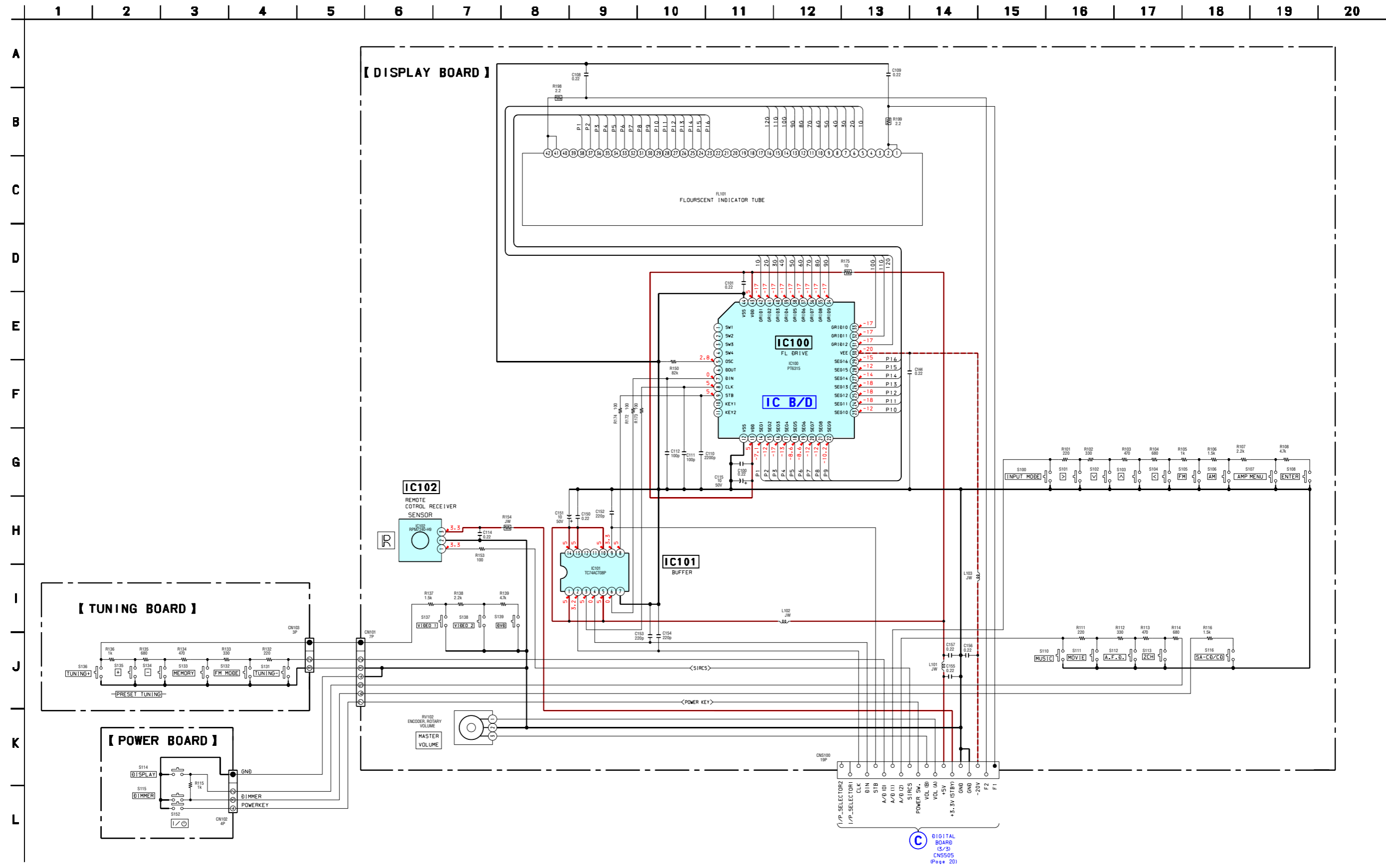

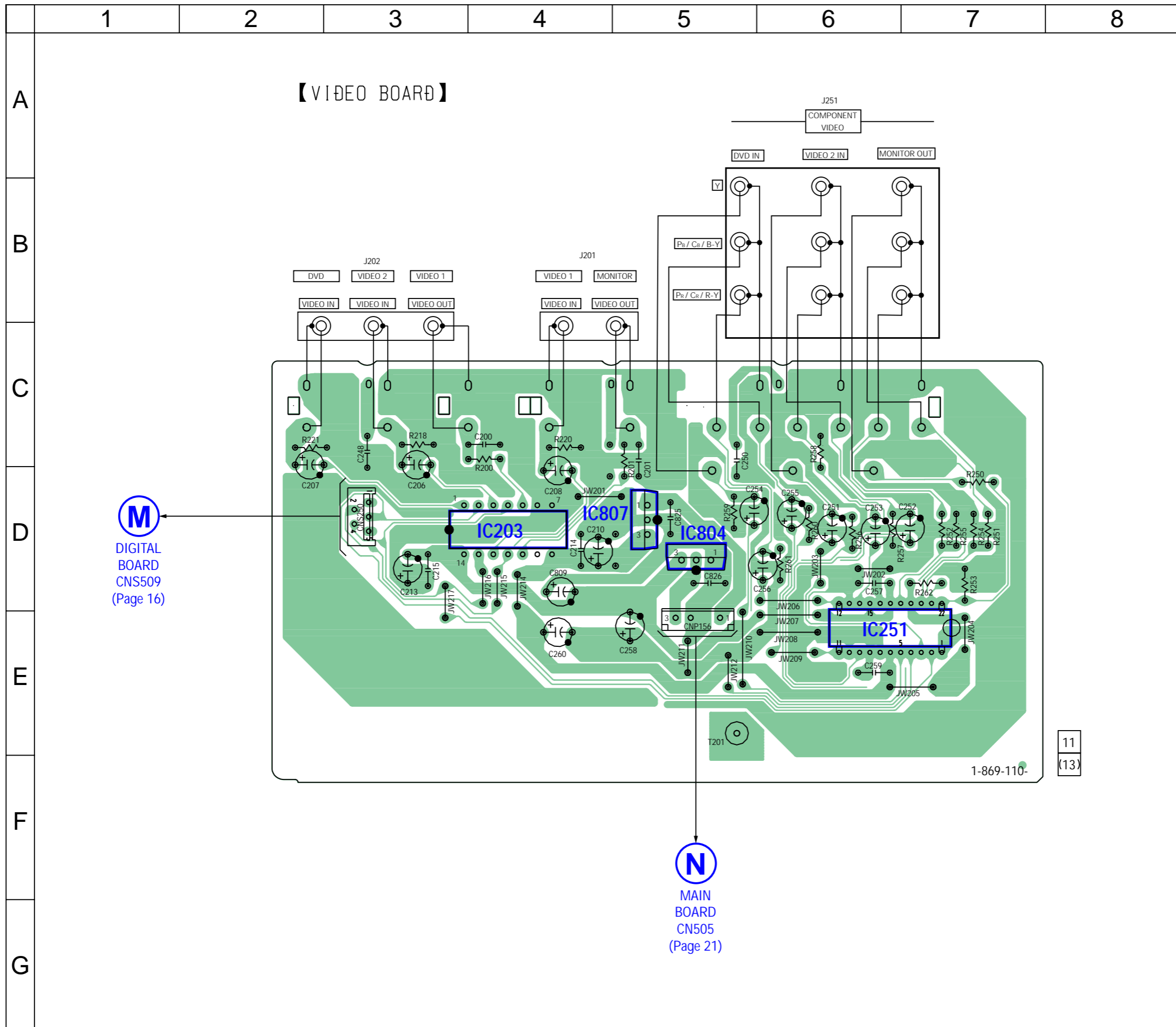

M
DIGITAL BOARD
CNS509
(Page 16)

N
MAIN BOARD
CN505
(Page 21)

11
(13)

1-869-110-

3-18. SCHEMATIC DIAGRAM - VIDEO BOARD - • See page 34, 35 for IC Block Diagrams.

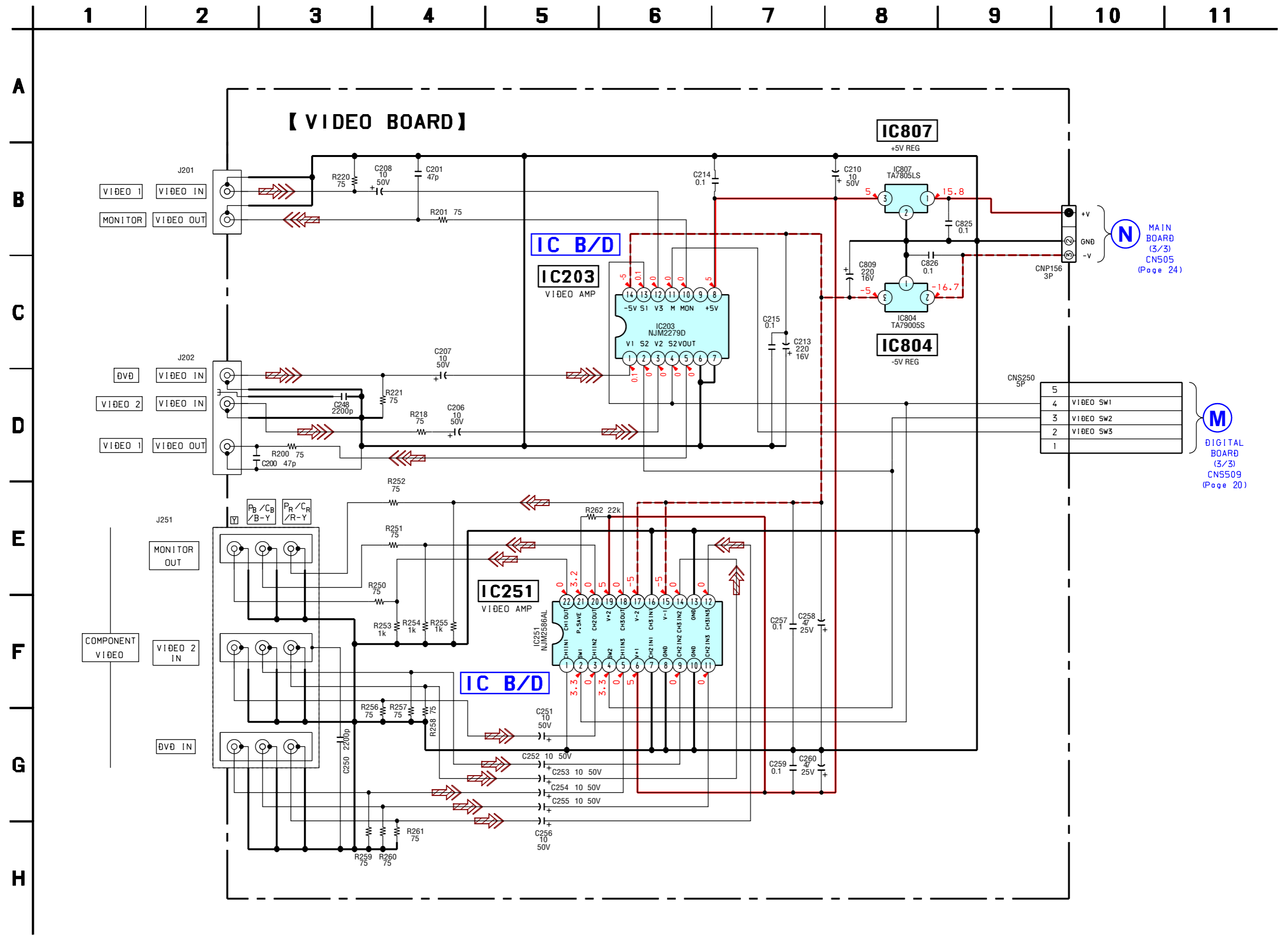

• IC Block Diagrams
– DIGITAL Board –

IC1131 BR24L16F-WE2

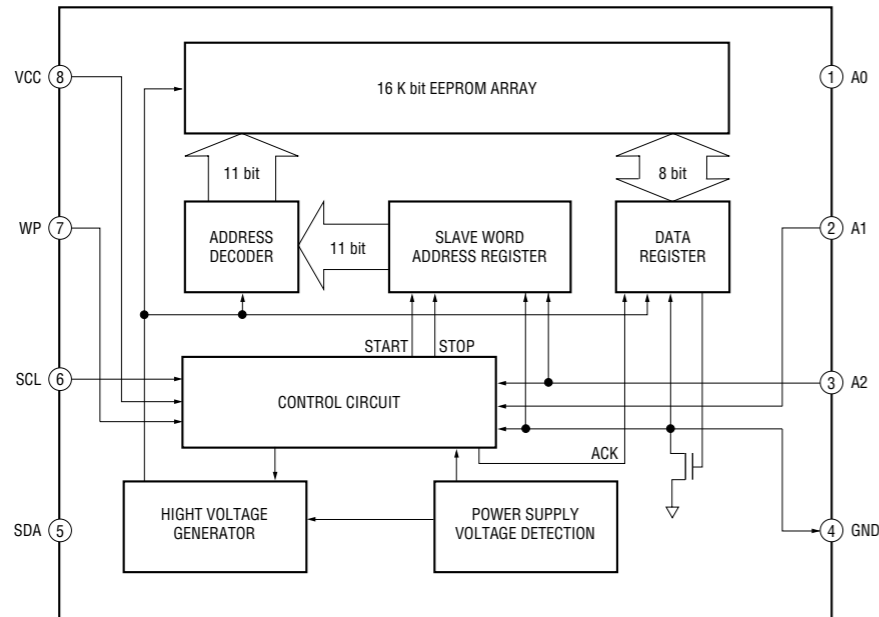

IC1452 PCM1602APT

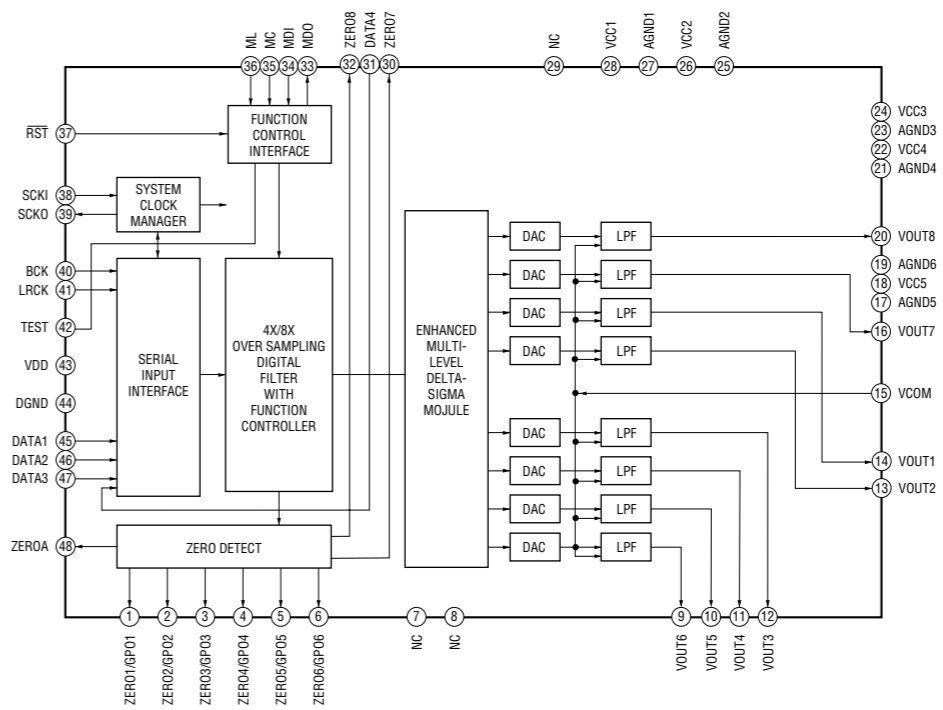

IC1301 LC89056W-E

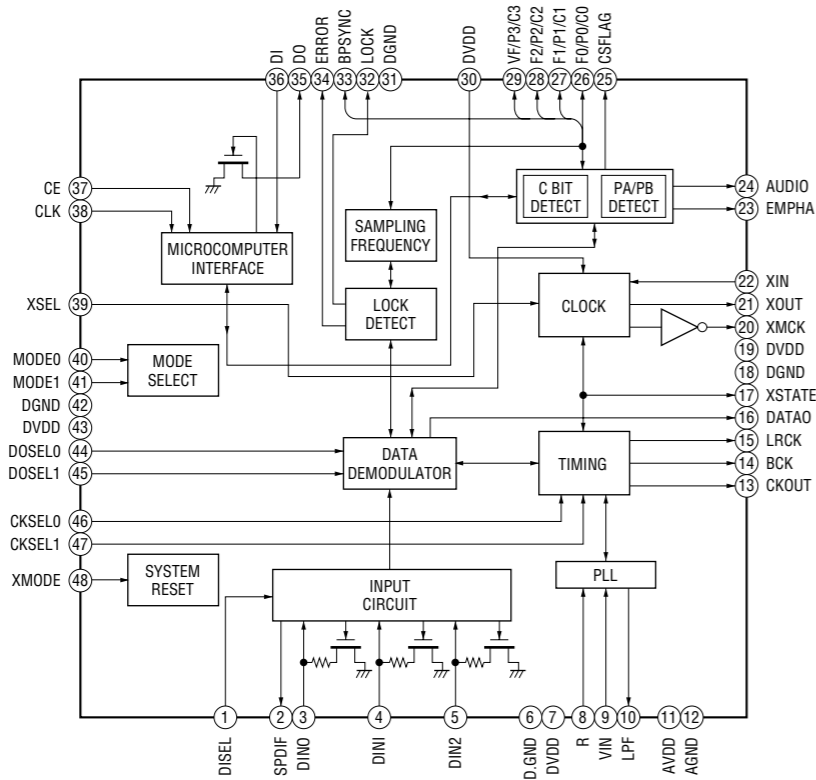

IC1502 IS61LV6416-10TLT

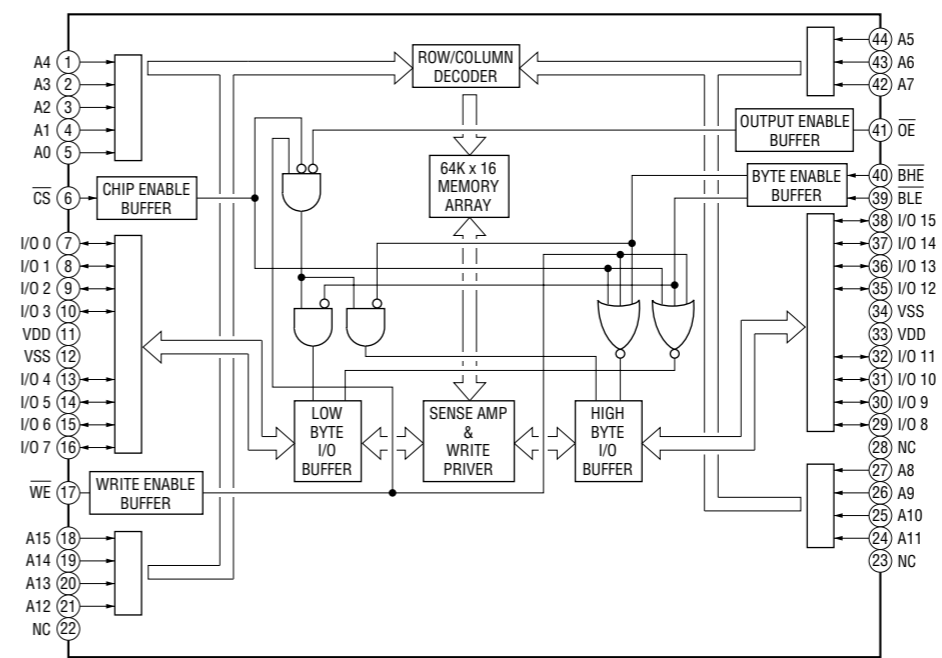

IC1503 TC7WH157FU (TE12R)

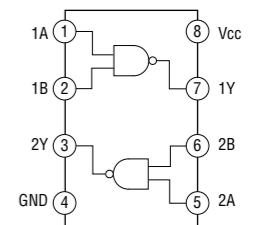

– DIGITAL Board –

IC1401 PCM1800E/2K

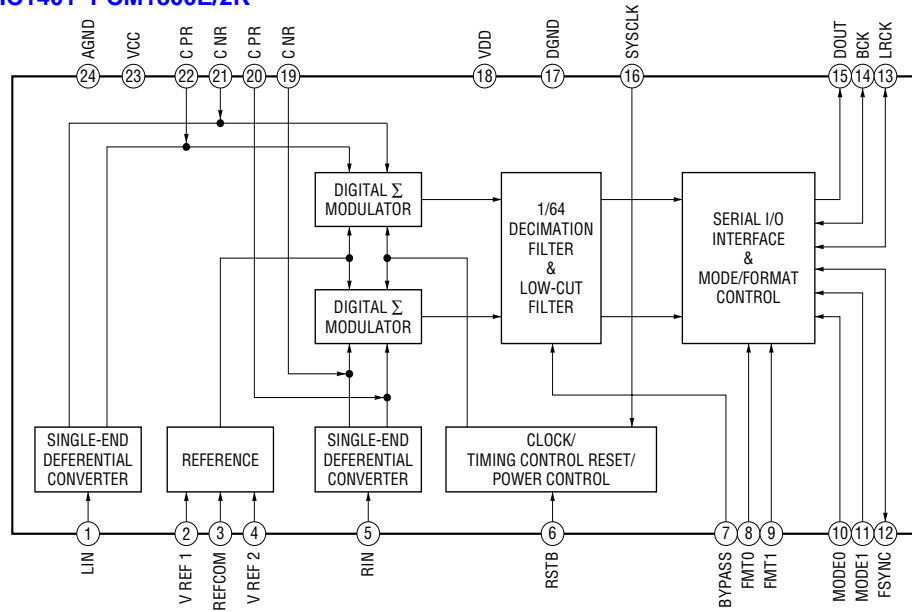

– MAIN Board –

IC501, IC601, IC701 STK350-530-E

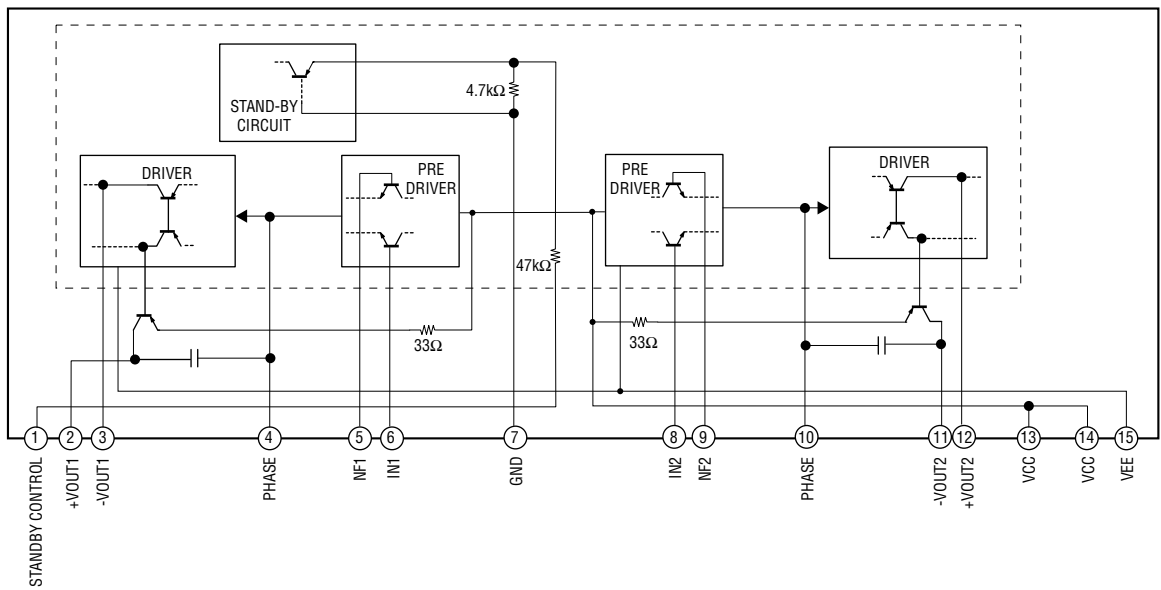

IC501, IC601, IC701 STK-350-530T-E

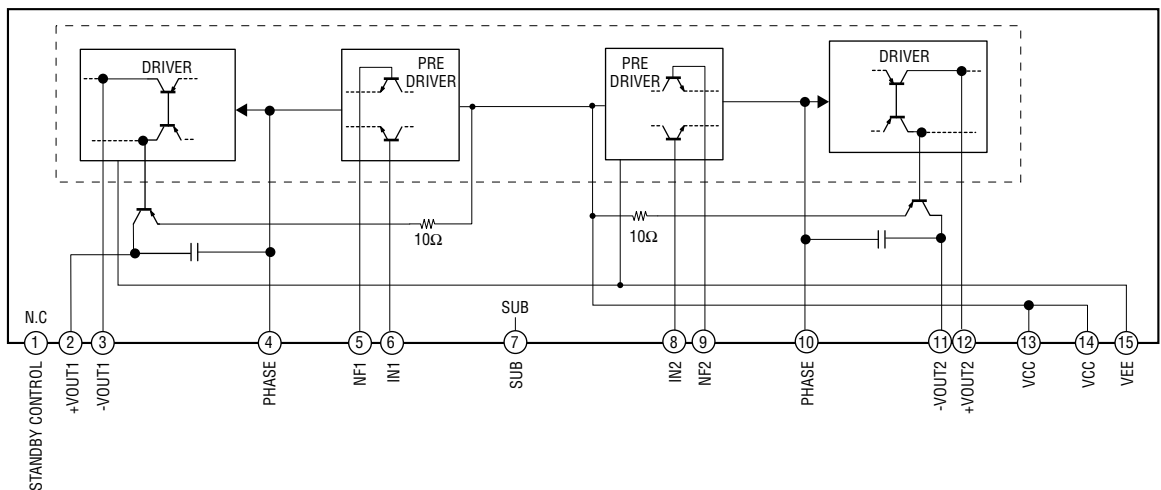

– MAIN Board –

IC400 M61542FP

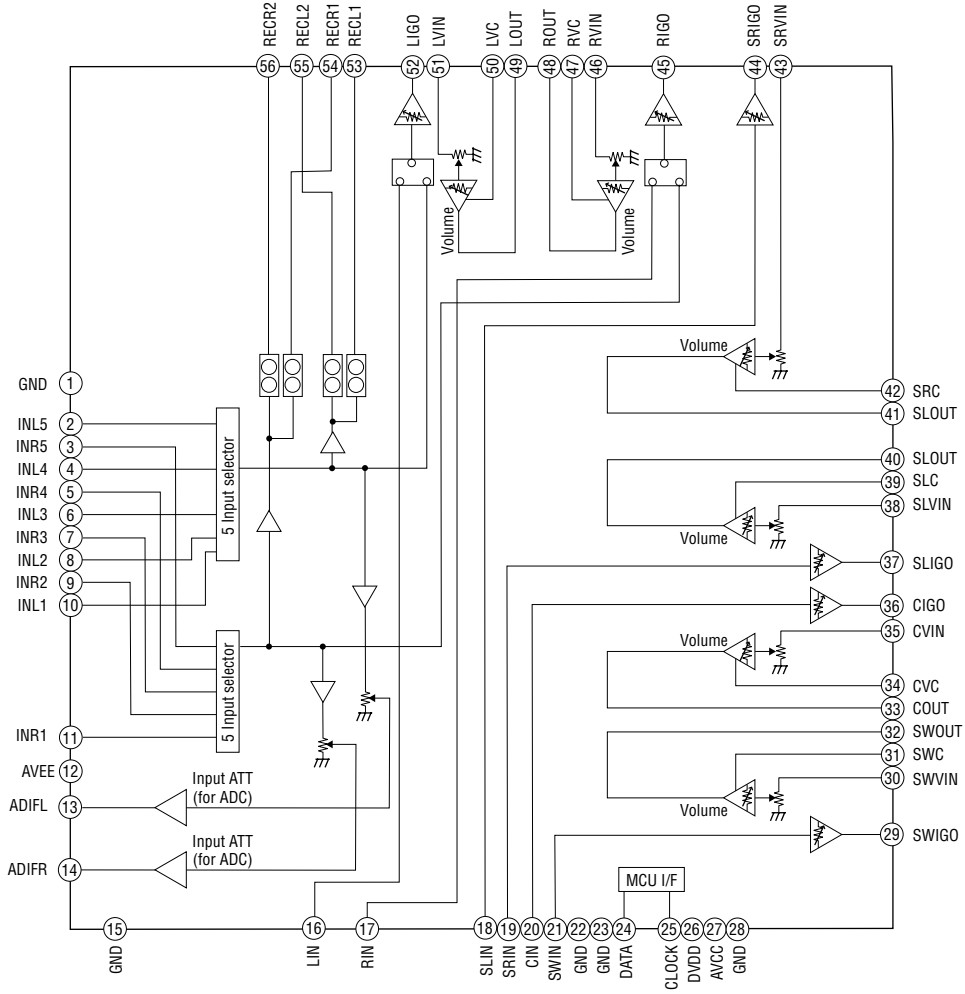

– VIDEO Board –

IC251 NJM2586AL

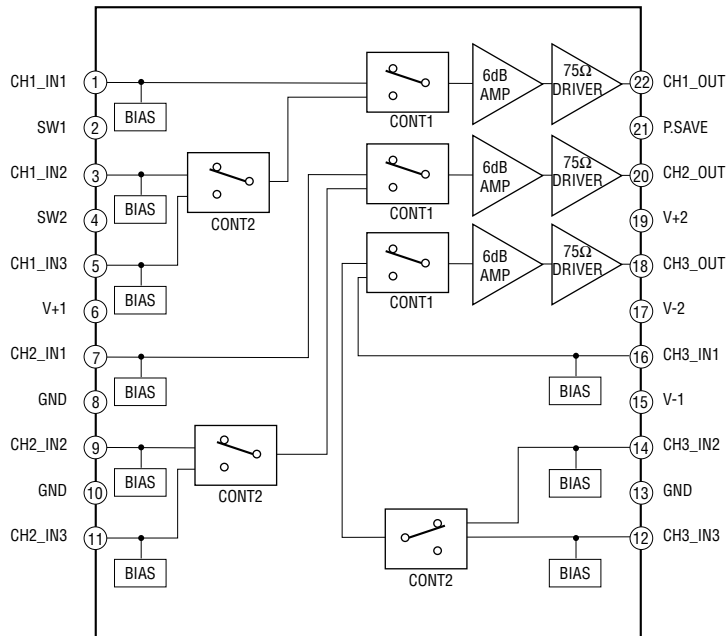

– VIDEO Board –

IC203 NJM2279D

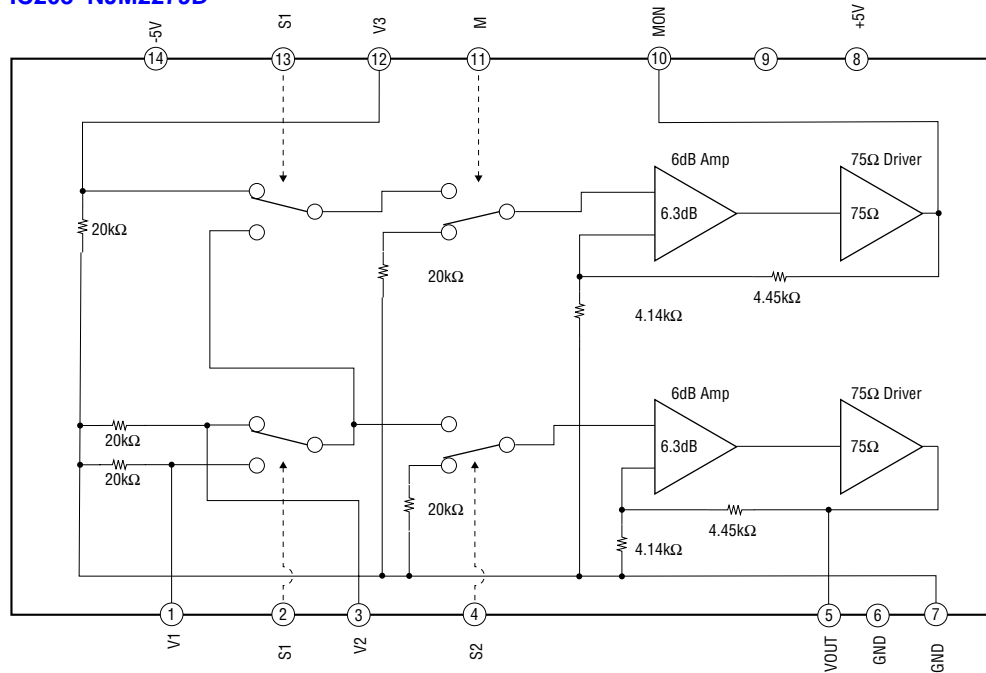

– DISPLAY Board –

IC100 PT6315

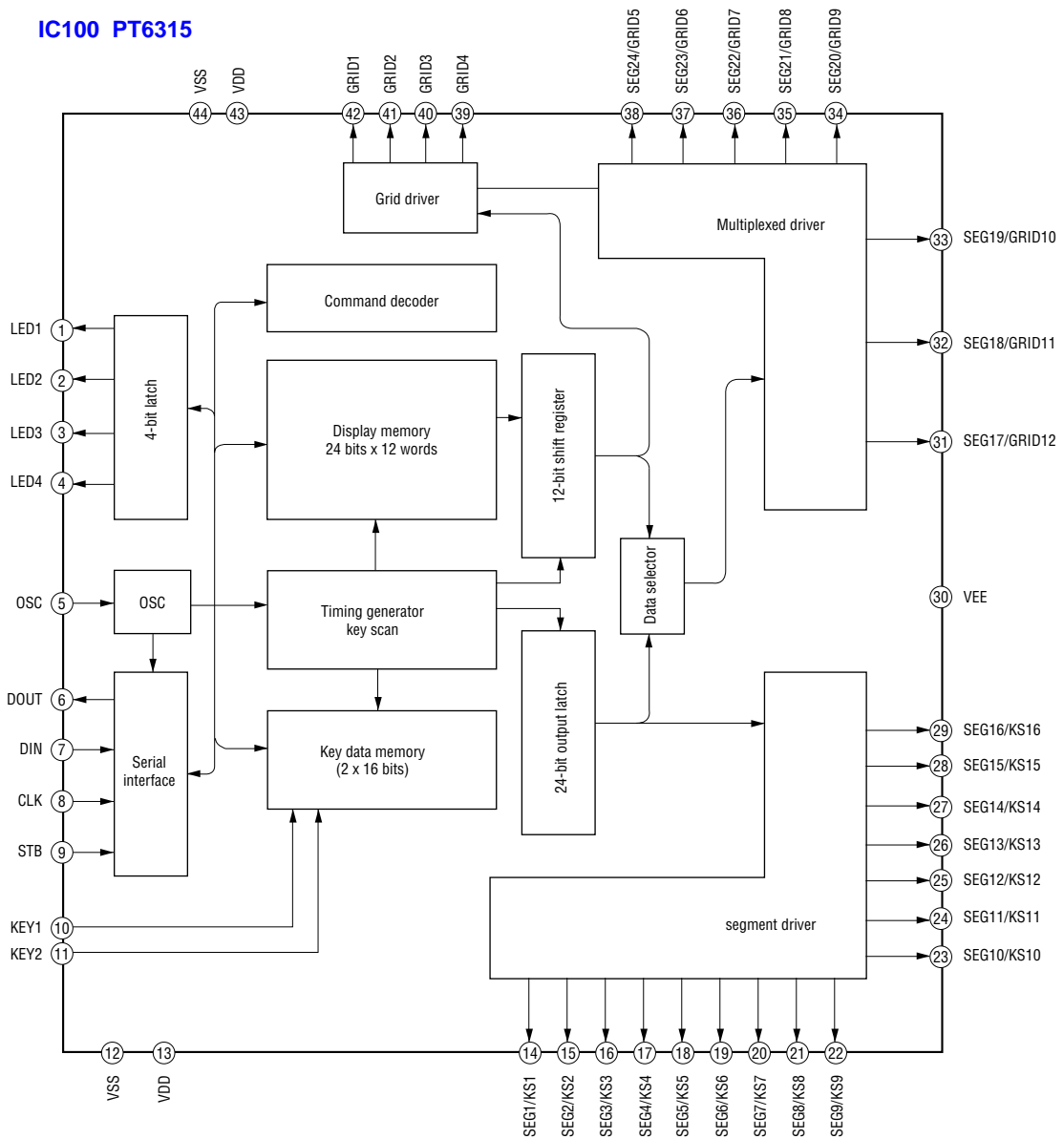

• IC Pin Function Description

DIGITAL BOARD IC1101 MB90488BPF-G-216E1 (SYSTEM CONTROL)

Pin No.	Pin Name	I/O	Description
1	DATAO	I	Audio data signal input from DIR
2	GP9	I	GP9 signal input from DSP
3	BST	O	BST signal output to DSP
4	HCS	O	HCS signal output to DSP
5	HACN	I	HACN signal input from DSP
6	XRST	O	Reset signal output to DSP
7	PM	O	PM signal output to DSP
8	GP12	O	GP12 signal output to DSP
9	PCM1800_RST	O	IC reset signal output to ADC
10	PCM1608_RST	O	IC reset signal output to DAC
11	VSS	—	Ground terminal
12	PCM1608_ML	O	Latch signal output to DAC
13	PCM1608_MC	O	Clock signal output to DAC
14	PCM1608_MDI	O	IC data output to DAC
15	PCM1608_MDO	I	IC data input from DAC
16	T.SERIAL_CLK	O	Tuner clock signal output terminal
17	TUNER_DATA	O	Tuner data signal output terminal
18	HDOUT	I	HDOUT signal input from DSP
19	HDIN	O	HDIN signal output to DSP
20	HCLK	O	Clock signal output to DSP
21	VOL_CLK	O	Clock signal output to the ASP
22	VOL_DATA_LATCH	O	Data output to the ASP
23	VCC5	—	Power supply (+3.3V)
24	SYS_MUTE	O	Muting and error signal output
25	ANA/DIG	O	Analog signal or digital signal output terminal
26	NOT_USED	—	Not used
27	FLASH2	O	FLASH2 signal output (not used)
28	FLASH1	O	FLASH1 signal output (not used)
29	SDA	I	EEPROM data signal input terminal
30	SCL	O	EEPROM clock signal output terminal
31	I/P_SEL (A)	I	Input Encoder (A) signal input
32	I/P_SEL (B)	I	Input Encoder (B) signal input
33	NOT_USED	—	Not used
34	NOT_USED	—	Not used
35	AVCC	—	Analog power supply (+3.3V)
36	AVRH	I	Analog reference voltage input (+3.3V)
37	AVSS	—	Analog ground terminal
38	A/D0	I	Function key push signal input
39	A/D1	I	Function key push signal input
40	A/D2	I	Function key push signal input
41	VERSION	I	Version setting input terminal (DESTINATION)
42	VSS	—	Ground terminal
43	RDS_SIG	I	RDS signal detect input
44	MODEL	I	MODEL select input
45	ADCC_ANALOGUE_IN	I	ADCC signal input
46	VACS	I	VACS control signal input
47	FL_LAT	O	FL driver latch signal output

Pin No.	Pin Name	I/O	Description
48	STOP	I	AC off detect signal input
49	MD0	I	Operation mode setting input
50	MD1	I	Operation mode setting input
51	MD2	I	Operation mode setting input
52	RDS_CLK	I	RDS clock signal input
53	RDS_DATA	I	RDS data signal input
54	SIRCS	I	Data signal input from the remote control sensor
55	HP_DETECT	I	Headphone signal input
56	POWER_KEY	I	Power switch key detect signal input
57	ADCC_DSP_IN	O	ADCC DSP input
58	POWER_RY	O	Power relay control signal output
59	FL_DATA	O	FL driver signal output terminal
60	FL_CLK	O	FL driver clock signal output terminal
61	PROTECTOR	I	Protector status detect signal input
62	HP_RY	O	Headphone relay control signal output
63	FUSE_DETECT	I	Fuse detect signal input
64	VOL_ENC (A)	I	Volume signal input from rotary encoder
65	VOL_ENC (B)	I	Volume signal input from rotary encoder
66	FRONT_RY	O	Front speaker relay control signal output
67	C/SW_RY	O	Center speaker or Sub woofer speaker control signal output
68	REAR_RY	O	Rear speaker control signal output
69	NOT_USED	—	Not used
70	NOT_USED	—	Not used
71	NOT_USED	—	Not used
72	NOT_USED	—	Not used
73	DO	I	Frequency data signal input from the tuner
74	SLATCH	O	Latch signal output to the tuner
75	TUNED	I	Tuning a frequency signal input from the tuner
76	STEREO	I	Stereo tuning signal input from the tuner
77	RSTX	I	System reset input
78	MUTE	O	Muting signal output to the tuner
79	X1A	—	Not used
80	X0A	—	Ground terminal
81	VSS	—	Ground terminal
82	X0	—	Connection for a crystal resonator
83	X1	—	Connection for a crystal resonator
84	VCC3	—	Power supply (+3.3V)
85	NOT_USED	—	Not used
86	SW1	O	Video select control signal output
87	SW2	O	Video select control signal output
88	SW3	O	Video select control signal output
89	SW4	O	Video select control signal output
90	NOT_USED	—	Not used
91	NOT_USED	—	Not used
92	LRCK_SW	O	LRCK signal output to the selector
93	XMODE	O	Reset signal output to DIR
94	CKSEL 1	O	CKSEL control signal output to DIR
95	CLK	O	Clock signal output to DIR
96	CE	O	Chip enable signal output to DIR

Pin No.	Pin Name	I/O	Description
97	DI	O	Data signal output to DIR
98	DO	I	Data signal input from DIR
99	ERROR	I	PLL error muting signal input from DIR
100	XSTATE	I	XSTATE data signal input from DIR

SECTION 4 EXPLODED VIEWS

NOTE:

- -XX and -X mean standardized parts, so they may have some difference from the original one.
- The mechanical parts with no reference number in the exploded views are not supplied.
- Items marked "*" are not stocked since they are seldom required for routine service. Some delay should be anticipated when ordering these items.

- Abbreviation
 AUS : Australian model
 KR : Korean model
 RU : Russian model
 TH : Thai model
 TW : Taiwan model
- Color Indication of Appearance Parts
 Example:
 KNOB, BALANCE (WHITE) . . . (RED)
 ↑ ↑
 Parts Color Cabinet's Color

The components identified by mark Δ or dotted line with mark Δ are critical for safety. Replace only with part number specified.

4-1. FRONT PANEL SECTION

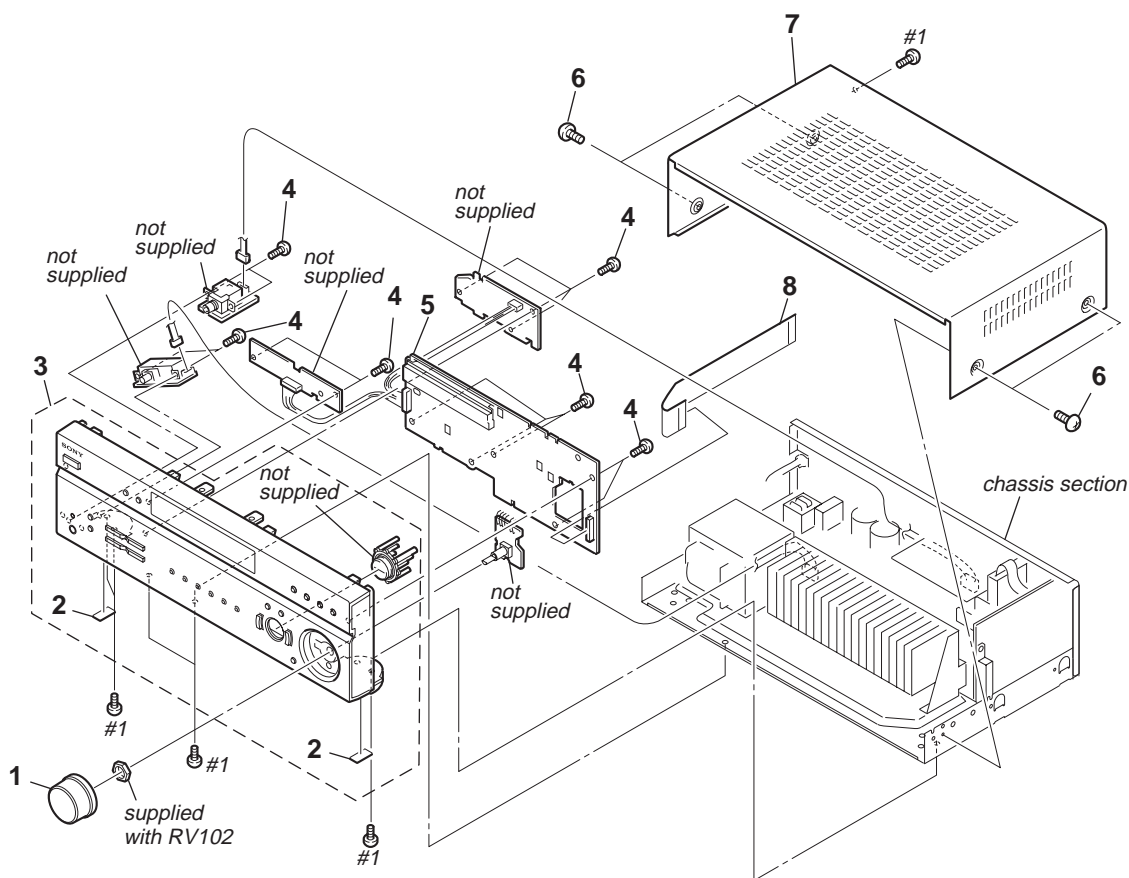

Ref. No.	Part No.	Description	Remark	Ref. No.	Part No.	Description	Remark
1	4-232-113-01	KNOB (VOL) (BLACK) (AEP, UK)		5	A-1157-676-A	DISPLAY BOARD, COMPLETE	
1	4-232-113-31	KNOB (VOL) (SILVER) (EXCEPT AEP, UK)		6	3-363-099-02	SCREW (CASE 3 TP2) (BLACK) (AEP, UK)	
2	4-977-358-01	CUSHION		6	3-363-099-11	SCREW (CASE 3 TP2) (SILVER)	(EXCEPT AEP, UK)
3	X-2103-292-1	FRONT PANEL ASSY (SILVER) (AEP, UK, RU)		7	4-245-939-01	CASE (BLACK) (AEP, UK)	
3	X-2103-295-1	FRONT PANEL ASSY (SILVER)	(KR, TH, TW, AUS)	7	4-245-939-61	CASE (SILVER) (EXCEPT AEP, UK)	
3	X-2109-618-1	FRONT PANEL ASSY (BLACK) (AEP, UK)		8	1-829-004-11	WIRE (FLAT TYPE) (19 CORE)	
4	3-087-053-01	+BVTP2.6 (3CR)		#1	7-685-646-79	SCREW +BVTP 3X8 TYPE2 IT-3	

4-2. CHASSIS SECTION

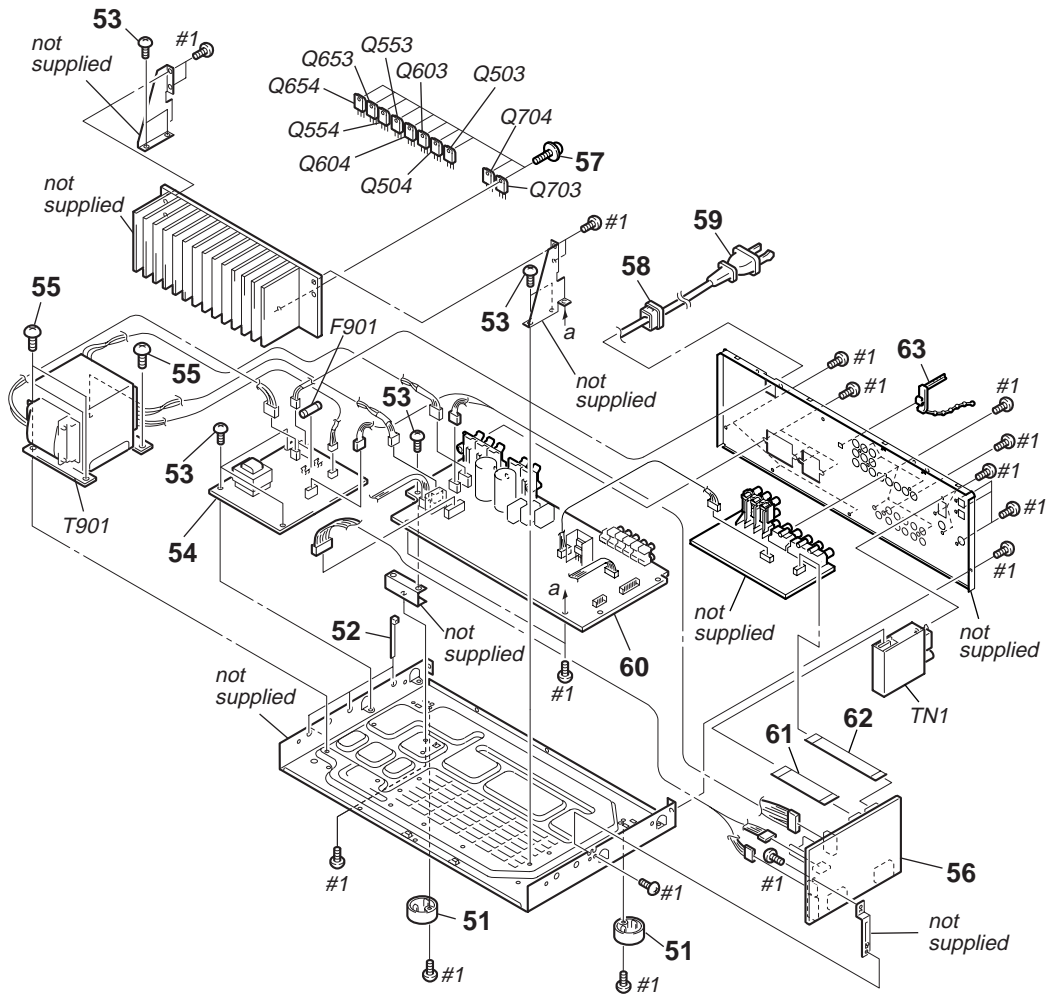

Ref. No.	Part No.	Description	Remark	Ref. No.	Part No.	Description	Remark
51	X-4953-448-1	FOOT ASSY		61	1-828-980-11	WIRE (FLAT TYPE) (15 CORE) (AEP, UK, RU)	
52	3-701-748-00	CLAMP		62	1-828-936-11	WIRE (FLAT TYPE) (5 CORE)	
53	3-077-331-21	+BV3 (3-CR)		63	4-956-370-12	BAND, PLUG FIXED (UK, AUS)	
54	A-1157-640-A	STANDBY BOARD, COMPLETE					
		(AEP, UK, RU, AUS)		△ F901	1-532-504-33	FUSE, TIME-LAG (T4A/250V) (TW)	
54	A-1185-845-A	STANDBY BOARD, COMPLETE (KR)		△ F901	1-532-464-33	FUSE (T2.5AL/250V) (EXCEPT TW)	
54	A-1185-846-A	STANDBY BOARD, COMPLETE (TW)		Q503	6-702-390-01	IC MN2488-OPY-MK	
54	A-1185-847-A	STANDBY BOARD, COMPLETE (TH)		Q504	6-702-391-01	IC MP1620-OPY-MK	
55	4-249-675-01	+BV SUMITITE S 4X6 ROUND		Q553	6-702-390-01	IC MN2488-OPY-MK	
56	A-1179-813-A	DIGITAL BOARD, COMPLETE (AEP, UK, RU)		Q554	6-702-391-01	IC MP1620-OPY-MK	
56	A-1185-840-A	DIGITAL BOARD, COMPLETE (AUS)		Q603	6-702-390-01	IC MN2488-OPY-MK	
				Q604	6-702-391-01	IC MP1620-OPY-MK	
56	A-1185-841-A	DIGITAL BOARD, COMPLETE (KR)		Q653	6-702-390-01	IC MN2488-OPY-MK	
56	A-1185-848-A	DIGITAL BOARD, COMPLETE (TH)		Q654	6-702-391-01	IC MP1620-OPY-MK	
56	A-1185-849-A	DIGITAL BOARD, COMPLETE (TW)					
57	3-905-609-01	SCREW (TRANSISTOR)		Q703	6-702-390-01	IC MN2488-OPY-MK	
* 58	3-703-244-00	BUSHING (2104), CORD		Q704	6-702-391-01	IC MP1620-OPY-MK	
△ 59	1-696-847-11	CORD, POWER (AUS)		△ T901	1-443-916-11	POWER TRANSFORMER (EXCEPT TH, TW)	
△ 59	1-769-079-23	CORD, POWER (KR)		△ T901	1-443-918-11	POWER TRANSFORMER (TH)	
△ 59	1-777-071-82	CORD, POWER (AEP, UK, RU, TH)		△ T901	1-445-030-11	POWER TRANSFORMER (TW)	
△ 59	1-827-597-41	CORD, POWER (TW)		TN1	1-693-676-21	TUNER (AEP, UK, RU)	
60	A-1179-811-A	MAIN BOARD, COMPLETE (EXCEPT TW)		TN1	1-693-678-11	TUNER (KR, TH, TW, AUS)	
				#1	7-685-646-79	SCREW +BVTP 3X8 TYPE2 IT-3	
60	A-1187-012-A	MAIN BOARD, COMPLETE (TW)					
61	1-828-963-11	WIRE (FLAT TYPE) (11 CORE)	(KR, TH, TW, AUS)				

SECTION 5
ELECTRICAL PARTS LIST

ADCC DIGITAL

NOTE:

- Due to standardization, replacements in the parts list may be different from the parts specified in the diagrams or the components used on the set.
- -XX and -X mean standardized parts, so they may have some difference from the original one.
- RESISTORS
All resistors are in ohms.
METAL: Metal-film resistor.
METAL OXIDE: Metal oxide-film resistor.
F: nonflammable
- COILS
uH: μ H

- CAPACITORS
uF: μ F
- Items marked “*” are not stocked since they are seldom required for routine service. Some delay should be anticipated when ordering these items.
- SEMICONDUCTORS
In each case, u: μ , for example:
uA. . . : μ A. . . uPA. . . : μ PA. . .
uPB. . . : μ PB. . . uPC. . . : μ PC. . .
uPD. . . : μ PD. . .
- Accessories are given in the last of this parts list.

When indicating parts by reference number, please include the board name.

The components identified by mark Δ or dotted line with mark Δ are critical for safety. Replace only with part number specified.

- Abbreviation
AUS : Australian model
KR : Korean model
RU : Russian model
TH : Thai model
TW : Taiwan model

Ref. No.	Part No.	Description	Remark	Ref. No.	Part No.	Description	Remark
		ADCC BOARD *****					
		< CAPACITOR >					
C2001	1-128-809-11	CERAMIC	100PF 5% 50V		A-1179-813-A	DIGITAL BOARD, COMPLETE (AEP, UK, RU)	
C2002	1-126-160-11	ELECT	1uF 20% 50V		A-1185-840-A	DIGITAL BOARD, COMPLETE (AUS)	
C2003	1-127-882-31	CERAMIC	0.033uF 10% 50V		A-1185-841-A	DIGITAL BOARD, COMPLETE (KR)	
C2005	1-128-803-11	CERAMIC	33PF 5% 50V		A-1185-848-A	DIGITAL BOARD, COMPLETE (TH)	
C2006	1-126-160-11	ELECT	1uF 20% 50V		A-1185-849-A	DIGITAL BOARD, COMPLETE (TW)	

					7-685-646-79	SCREW +BVTP 3X8 TYPE2 IT-3	
						< CAPACITOR >	
C2008	1-128-806-11	CERAMIC	56PF 5% 50V	C1001	1-126-925-91	ELECT 470uF 20% 10V	
C2010	1-127-882-31	CERAMIC	0.033uF 10% 50V	C1002	1-100-566-91	CERAMIC CHIP 0.1uF 10% 25V	
C2011	1-127-880-11	CERAMIC	0.022uF 10% 50V	C1004	1-100-566-91	CERAMIC CHIP 0.1uF 10% 25V	
C2012	1-127-880-11	CERAMIC	0.022uF 10% 50V	C1005	1-100-566-91	CERAMIC CHIP 0.1uF 10% 25V	
C2013	1-126-160-11	ELECT	1uF 20% 50V	C1021	1-100-566-91	CERAMIC CHIP 0.1uF 10% 25V	
C2014	1-124-465-00	ELECT	0.47uF 20% 50V	C1022	1-126-925-91	ELECT 470uF 20% 10V	
C2018	1-127-888-11	CERAMIC	0.1uF 10% 50V	C1031	1-100-566-91	CERAMIC CHIP 0.1uF 10% 25V	
				C1032	1-126-925-91	ELECT 470uF 20% 10V	
				C1063	1-100-566-91	CERAMIC CHIP 0.1uF 10% 25V	
							(AEP, UK, RU)
				C1064	1-126-947-11	ELECT 47uF 20% 35V	(AEP, UK, RU)
				C1100	1-100-566-91	CERAMIC CHIP 0.1uF 10% 25V	
				C1102	1-100-566-91	CERAMIC CHIP 0.1uF 10% 25V	
				C1103	1-126-947-11	ELECT 47uF 20% 35V	
				C1107	1-100-566-91	CERAMIC CHIP 0.1uF 10% 25V	
				C1108	1-100-566-91	CERAMIC CHIP 0.1uF 10% 25V	
				C1118	1-100-566-91	CERAMIC CHIP 0.1uF 10% 25V	
				C1119	1-100-566-91	CERAMIC CHIP 0.1uF 10% 25V	
				C1120	1-162-974-11	CERAMIC CHIP 0.01uF 50V	
				C1121	1-100-566-91	CERAMIC CHIP 0.1uF 10% 25V	
				C1122	1-100-566-91	CERAMIC CHIP 0.1uF 10% 25V	
				C1123	1-100-566-91	CERAMIC CHIP 0.1uF 10% 25V	
				C1124	1-100-566-91	CERAMIC CHIP 0.1uF 10% 25V	
				C1129	1-162-974-11	CERAMIC CHIP 0.01uF 50V	
				C1130	1-162-974-11	CERAMIC CHIP 0.01uF 50V	
				C1137	1-162-970-11	CERAMIC CHIP 0.01uF 10% 25V	
				C1138	1-100-566-91	CERAMIC CHIP 0.1uF 10% 25V	
				C1139	1-100-566-91	CERAMIC CHIP 0.1uF 10% 25V	
				C1140	1-100-566-91	CERAMIC CHIP 0.1uF 10% 25V	
				C1142	1-100-566-91	CERAMIC CHIP 0.1uF 10% 25V	
				C1147	1-162-960-11	CERAMIC CHIP 220PF 10% 50V	
				C1148	1-162-960-11	CERAMIC CHIP 220PF 10% 50V	
				C1149	1-162-960-11	CERAMIC CHIP 220PF 10% 50V	
				C1206	1-164-227-11	CERAMIC CHIP 0.022uF 10% 16V	
				C1251	1-100-566-91	CERAMIC CHIP 0.1uF 10% 25V	
				C1252	1-100-566-91	CERAMIC CHIP 0.1uF 10% 25V	

STR-DE400

Ver. 1.2

DIGITAL

Ref. No.	Part No.	Description	Remark
C1253	1-100-566-91	CERAMIC CHIP 0.1uF	10% 25V
C1254	1-162-960-11	CERAMIC CHIP 220PF	10% 50V
C1255	1-162-960-11	CERAMIC CHIP 220PF	10% 50V
C1299	1-100-566-91	CERAMIC CHIP 0.1uF	10% 25V
C1301	1-100-566-91	CERAMIC CHIP 0.1uF	10% 25V
C1302	1-162-974-11	CERAMIC CHIP 0.01uF	50V
C1303	1-100-566-91	CERAMIC CHIP 0.1uF	10% 25V
C1304	1-162-974-11	CERAMIC CHIP 0.01uF	50V
C1305	1-100-566-91	CERAMIC CHIP 0.1uF	10% 25V
C1306	1-126-947-11	ELECT 47uF	20% 35V
C1308	1-100-566-91	CERAMIC CHIP 0.1uF	10% 25V
C1309	1-162-918-11	CERAMIC CHIP 18PF	5% 50V
C1310	1-162-918-11	CERAMIC CHIP 18PF	5% 50V
C1312	1-100-566-91	CERAMIC CHIP 0.1uF	10% 25V
C1313	1-162-927-11	CERAMIC CHIP 100PF	5% 50V
C1314	1-100-566-91	CERAMIC CHIP 0.1uF	10% 25V
C1315	1-100-566-91	CERAMIC CHIP 0.1uF	10% 25V
C1352	1-100-566-91	CERAMIC CHIP 0.1uF	10% 25V
C1353	1-100-566-91	CERAMIC CHIP 0.1uF	10% 25V
C1355	1-104-662-91	ELECT 22uF	20% 25V
C1356	1-162-974-11	CERAMIC CHIP 0.01uF	50V
C1357	1-162-905-11	CERAMIC CHIP 1PF	0.25PF 50V
C1358	1-100-566-91	CERAMIC CHIP 0.1uF	10% 25V
C1359	1-126-916-11	ELECT 1000uF	20% 6.3V
C1360	1-162-923-11	CERAMIC CHIP 47PF	5% 50V
C1361	1-100-566-91	CERAMIC CHIP 0.1uF	10% 25V
C1362	1-100-566-91	CERAMIC CHIP 0.1uF	10% 25V
C1401	1-100-566-91	CERAMIC CHIP 0.1uF	10% 25V
C1402	1-126-947-11	ELECT 47uF	20% 35V
C1403	1-126-964-11	ELECT 10uF	20% 50V
C1404	1-100-566-91	CERAMIC CHIP 0.1uF	10% 25V
C1405	1-162-962-11	CERAMIC CHIP 470PF	10% 50V
C1406	1-126-963-11	ELECT 4.7uF	20% 50V
C1407	1-126-963-11	ELECT 4.7uF	20% 50V
C1408	1-162-962-11	CERAMIC CHIP 470PF	10% 50V
C1409	1-100-566-91	CERAMIC CHIP 0.1uF	10% 25V
C1418	1-126-964-11	ELECT 10uF	20% 50V
C1422	1-162-963-11	CERAMIC CHIP 680PF	10% 50V
C1423	1-162-961-11	CERAMIC CHIP 330PF	10% 50V
C1428	1-126-964-11	ELECT 10uF	20% 50V
C1432	1-162-963-11	CERAMIC CHIP 680PF	10% 50V
C1433	1-162-961-11	CERAMIC CHIP 330PF	10% 50V
C1438	1-126-964-11	ELECT 10uF	20% 50V
C1441	1-162-963-11	CERAMIC CHIP 680PF	10% 50V
C1442	1-162-961-11	CERAMIC CHIP 330PF	10% 50V
C1448	1-126-964-11	ELECT 10uF	20% 50V
C1450	1-100-566-91	CERAMIC CHIP 0.1uF	10% 25V
C1454	1-100-566-91	CERAMIC CHIP 0.1uF	10% 25V
C1457	1-126-964-11	ELECT 10uF	20% 50V
C1458	1-126-964-11	ELECT 10uF	20% 50V
C1460	1-126-964-11	ELECT 10uF	20% 50V
C1462	1-162-963-11	CERAMIC CHIP 680PF	10% 50V
C1463	1-162-961-11	CERAMIC CHIP 330PF	10% 50V
C1468	1-126-964-11	ELECT 10uF	20% 50V
C1472	1-162-963-11	CERAMIC CHIP 680PF	10% 50V
C1473	1-162-961-11	CERAMIC CHIP 330PF	10% 50V
C1481	1-162-961-11	CERAMIC CHIP 330PF	10% 50V
C1483	1-162-963-11	CERAMIC CHIP 680PF	10% 50V
C1487	1-162-966-11	CERAMIC CHIP 0.0022uF	10% 50V
C1491	1-126-964-11	ELECT 10uF	20% 50V
C1494	1-100-566-91	CERAMIC CHIP 0.1uF	10% 25V

Ref. No.	Part No.	Description	Remark
C1495	1-162-960-11	CERAMIC CHIP 220PF	10% 50V
C1501	1-100-566-91	CERAMIC CHIP 0.1uF	10% 25V
C1502	1-100-566-91	CERAMIC CHIP 0.1uF	10% 25V
C1503	1-100-566-91	CERAMIC CHIP 0.1uF	10% 25V
C1504	1-100-566-91	CERAMIC CHIP 0.1uF	10% 25V
C1505	1-100-566-91	CERAMIC CHIP 0.1uF	10% 25V
C1506	1-100-566-91	CERAMIC CHIP 0.1uF	10% 25V
C1507	1-100-566-91	CERAMIC CHIP 0.1uF	10% 25V
C1508	1-100-566-91	CERAMIC CHIP 0.1uF	10% 25V
C1509	1-100-566-91	CERAMIC CHIP 0.1uF	10% 25V
C1510	1-100-566-91	CERAMIC CHIP 0.1uF	10% 25V
C1511	1-100-566-91	CERAMIC CHIP 0.1uF	10% 25V
C1513	1-100-566-91	CERAMIC CHIP 0.1uF	10% 25V
C1514	1-100-566-91	CERAMIC CHIP 0.1uF	10% 25V
C1515	1-126-925-91	ELECT 470uF	20% 10V
C1516	1-100-566-91	CERAMIC CHIP 0.1uF	10% 25V
C1517	1-126-925-91	ELECT 470uF	20% 10V
C1518	1-100-566-91	CERAMIC CHIP 0.1uF	10% 25V
C1519	1-100-566-91	CERAMIC CHIP 0.1uF	10% 25V
C1520	1-100-566-91	CERAMIC CHIP 0.1uF	10% 25V
C1521	1-162-920-11	CERAMIC CHIP 27PF	5% 50V
C1522	1-162-920-11	CERAMIC CHIP 27PF	5% 50V
C1525	1-126-925-91	ELECT 470uF	20% 10V
C1547	1-162-966-11	CERAMIC CHIP 0.0022uF	10% 50V
C1566	1-162-966-11	CERAMIC CHIP 0.0022uF	10% 50V
C1567	1-162-966-11	CERAMIC CHIP 0.0022uF	10% 50V
C1568	1-162-966-11	CERAMIC CHIP 0.0022uF	10% 50V
C1569	1-162-966-11	CERAMIC CHIP 0.0022uF	10% 50V
C1604	1-100-566-91	CERAMIC CHIP 0.1uF	10% 25V
C1605	1-100-566-91	CERAMIC CHIP 0.1uF	10% 25V
C1620	1-100-566-91	CERAMIC CHIP 0.1uF	10% 25V
C1905	1-100-566-91	CERAMIC CHIP 0.1uF	10% 25V
C1906	1-126-925-91	ELECT 470uF	20% 10V
C1908	1-126-925-91	ELECT 470uF	20% 10V
C1913	1-100-566-91	CERAMIC CHIP 0.1uF	10% 25V
C1914	1-126-947-11	ELECT 47uF	20% 35V
< CONNECTOR >			
CNP503	1-784-921-11	PIN, CONNECTOR 4P	
CNP504	1-784-922-11	PIN, CONNECTOR 5P	
CNP505	1-784-924-11	PIN, CONNECTOR 8P	
CNS501	1-573-829-11	CONNECTOR, BOARD TO BOARD 15P	
CNS502	1-766-719-41	CONNECTOR, BOARD TO BOARD 10P	
CNS505	1-784-780-11	CONNECTOR, FFC 19P	
CNS508	1-568-830-11	CONNECTOR, FFC 11P (KR, TH, TW, AUS)	
CNS508	1-784-776-11	CONNECTOR, FFC 15P (AEP, UK, RU)	
CNS509	1-784-766-11	CONNECTOR, FFC 5P	
< DIODE >			
D1001	8-719-053-18	DIODE 1SR154-400TE-25	
D1003	8-719-049-09	DIODE 1SS367-T3SONY	
D1004	8-719-049-09	DIODE 1SS367-T3SONY	
D1107	6-501-193-01	DIODE 1SS355WTE-17	
D1110	6-501-193-01	DIODE 1SS355WTE-17	
D1111	6-501-193-01	DIODE 1SS355WTE-17	
D1112	8-719-049-09	DIODE 1SS367-T3SONY	
D1113	8-719-049-09	DIODE 1SS367-T3SONY	
D1114	8-719-049-09	DIODE 1SS367-T3SONY	
D1301	6-501-193-01	DIODE 1SS355WTE-17	
D1302	6-501-193-01	DIODE 1SS355WTE-17	

Ref. No.	Part No.	Description	Remark	Ref. No.	Part No.	Description	Remark
		< FERRITE BEAD >		R1067	1-216-809-11	METAL CHIP	100 5% 1/10W
FB1101	1-400-862-11	BEAD, FERRITE		R1068	1-216-809-11	METAL CHIP	100 5% 1/10W
FB1302	1-400-862-11	BEAD, FERRITE		R1071	1-216-827-11	METAL CHIP	3.3K 5% 1/10W
FB1305	1-400-862-11	BEAD, FERRITE		R1072	1-216-827-11	METAL CHIP	3.3K 5% 1/10W
FB1306	1-400-862-11	BEAD, FERRITE		R1073	1-216-827-11	METAL CHIP	3.3K 5% 1/10W
FB1308	1-400-862-11	BEAD, FERRITE		R1076	1-216-809-11	METAL CHIP	100 5% 1/10W
FB1405	1-400-862-11	BEAD, FERRITE		R1077	1-216-809-11	METAL CHIP	100 5% 1/10W
FB1452	1-400-862-11	BEAD, FERRITE		R1078	1-216-809-11	METAL CHIP	100 5% 1/10W
FB1453	1-400-862-11	BEAD, FERRITE		R1082	1-216-809-11	METAL CHIP	100 5% 1/10W
FB1501	1-400-862-11	BEAD, FERRITE		R1083	1-216-833-11	METAL CHIP	10K 5% 1/10W
FB1502	1-400-862-11	BEAD, FERRITE		R1088	1-216-833-11	METAL CHIP	10K 5% 1/10W
FB1503	1-400-862-11	BEAD, FERRITE		R1094	1-216-833-11	METAL CHIP	10K 5% 1/10W (KR, TH, TW, AUS)
		< IC >		R1095	1-216-833-11	METAL CHIP	10K 5% 1/10W (KR, TH, TW, AUS)
IC1001	8-759-231-53	IC TA7805S		R1096	1-216-833-11	METAL CHIP	10K 5% 1/10W
IC1031	6-703-547-01	IC TA7805LS		R1097	1-216-845-11	METAL CHIP	100K 5% 1/10W
IC1071	6-702-771-01	IC TA78033LS (AEP, UK, RU)		R1105	1-216-833-11	METAL CHIP	10K 5% 1/10W
IC1101	6-806-692-01	IC MB90488BPF-G-216E1		R1106	1-216-809-11	METAL CHIP	100 5% 1/10W
IC1111	6-702-913-01	IC S-80929CNMC-G8ZT2G		R1107	1-216-825-11	METAL CHIP	2.2K 5% 1/10W
IC1131	6-704-004-01	IC BR24L16F-WE2		R1108	1-216-825-11	METAL CHIP	2.2K 5% 1/10W
IC1301	8-759-825-15	IC LC89056W-E		R1109	1-216-825-11	METAL CHIP	2.2K 5% 1/10W
IC1303	8-759-242-70	IC TC7WU04F (TE12R)		R1112	1-216-809-11	METAL CHIP	100 5% 1/10W
IC1352	6-600-466-01	IC TORX147L (VIDEO 1 IN/OPTICAL)		R1113	1-216-809-11	METAL CHIP	100 5% 1/10W
IC1353	6-600-466-01	IC TORX147L (VIDEO 2 IN/OPTICAL)		R1115	1-216-809-11	METAL CHIP	100 5% 1/10W
IC1401	8-759-560-56	IC PCM1800E/2K		R1117	1-216-821-11	METAL CHIP	1K 5% 1/10W
IC1403	8-759-710-97	IC NJM4565M-D		R1118	1-216-821-11	METAL CHIP	1K 5% 1/10W
IC1404	8-759-710-97	IC NJM4565M-D		R1119	1-216-821-11	METAL CHIP	1K 5% 1/10W
IC1405	8-759-710-97	IC NJM4565M-D		R1120	1-216-821-11	METAL CHIP	1K 5% 1/10W
IC1452	6-708-784-01	IC PCM1602APT		R1121	1-216-809-11	METAL CHIP	100 5% 1/10W
IC1501	6-707-754-01	IC CXD9862R		R1122	1-216-809-11	METAL CHIP	100 5% 1/10W
IC1502	6-704-832-01	IC IS61LV6416-10TLT		R1123	1-216-809-11	METAL CHIP	100 5% 1/10W
IC1503	8-759-546-74	IC TC7WH157FU (TE12R)		R1124	1-216-809-11	METAL CHIP	100 5% 1/10W
IC1901	6-707-168-01	IC SI-3008KWFE		R1127	1-216-809-11	METAL CHIP	100 5% 1/10W
IC1902	8-759-701-59	IC TA7809S		R1128	1-216-809-11	METAL CHIP	100 5% 1/10W
IC1904	6-705-463-01	IC BA33BC0T		R1129	1-216-809-11	METAL CHIP	100 5% 1/10W
		< JACK >		R1134	1-216-809-11	METAL CHIP	100 5% 1/10W
J1301	1-794-972-11	JACK, PIN 1P (DVD IN/COAXIAL)		R1135	1-216-809-11	METAL CHIP	100 5% 1/10W
		< JUMPER RESISTOR >		R1136	1-216-809-11	METAL CHIP	100 5% 1/10W
JR1020	1-216-864-11	SHORT CHIP 0		R1137	1-216-809-11	METAL CHIP	100 5% 1/10W
JR1202	1-216-864-11	SHORT CHIP 0 (KR, TH, TW, AUS)		R1140	1-216-809-11	METAL CHIP	100 5% 1/10W
JR1502	1-216-864-11	SHORT CHIP 0		R1142	1-216-809-11	METAL CHIP	100 5% 1/10W
JR1511	1-400-862-11	BEAD, FERRITE		R1143	1-216-809-11	METAL CHIP	100 5% 1/10W
		< RESISTOR >		R1144	1-216-809-11	METAL CHIP	100 5% 1/10W
R1035	1-216-825-11	METAL CHIP	2.2K 5% 1/10W	R1149	1-216-809-11	METAL CHIP	100 5% 1/10W
R1039	1-216-833-11	METAL CHIP	10K 5% 1/10W	R1150	1-216-809-11	METAL CHIP	100 5% 1/10W
R1041	1-216-809-11	METAL CHIP	100 5% 1/10W	R1151	1-216-809-11	METAL CHIP	100 5% 1/10W
R1042	1-216-809-11	METAL CHIP	100 5% 1/10W	R1152	1-216-809-11	METAL CHIP	100 5% 1/10W
R1044	1-216-809-11	METAL CHIP	100 5% 1/10W	R1153	1-216-809-11	METAL CHIP	100 5% 1/10W
R1049	1-216-833-11	METAL CHIP	10K 5% 1/10W	R1154	1-216-809-11	METAL CHIP	100 5% 1/10W
R1058	1-216-813-11	METAL CHIP	220 5% 1/10W (AEP, UK, RU)	R1155	1-216-809-11	METAL CHIP	100 5% 1/10W
R1059	1-216-813-11	METAL CHIP	220 5% 1/10W (AEP, UK, RU)	R1156	1-216-864-11	SHORT CHIP	0
R1065	1-216-809-11	METAL CHIP	100 5% 1/10W	R1157	1-216-864-11	SHORT CHIP	0
R1066	1-216-809-11	METAL CHIP	100 5% 1/10W	R1159	1-216-827-11	METAL CHIP	3.3K 5% 1/10W
				R1160	1-216-809-11	METAL CHIP	100 5% 1/10W
				R1161	1-216-809-11	METAL CHIP	100 5% 1/10W
				R1162	1-216-809-11	METAL CHIP	100 5% 1/10W
				R1163	1-216-841-11	METAL CHIP	47K 5% 1/10W
				R1164	1-216-829-11	METAL CHIP	4.7K 5% 1/10W
				R1167	1-216-809-11	METAL CHIP	100 5% 1/10W

STR-DE400

Ver. 1.2

DIGITAL

Ref. No.	Part No.	Description		Remark	Ref. No.	Part No.	Description		Remark
R1168	1-216-809-11	METAL CHIP	100	5%	1/10W	R1458	1-216-833-11	METAL CHIP	10K 5% 1/10W
R1175	1-216-809-11	METAL CHIP	100	5%	1/10W (AEP, UK, RU)	R1459	1-216-833-11	METAL CHIP	10K 5% 1/10W
R1179	1-216-833-11	METAL CHIP	10K	5%	1/10W	R1460	1-216-864-11	SHORT CHIP	0
R1180	1-216-833-11	METAL CHIP	10K	5%	1/10W	R1461	1-216-864-11	SHORT CHIP	0
R1186	1-216-833-11	METAL CHIP	10K	5%	1/10W	R1463	1-218-867-11	METAL CHIP	6.8K 5% 1/10W
R1187	1-216-833-11	METAL CHIP	10K	5%	1/10W	R1464	1-216-864-11	SHORT CHIP	0
R1189	1-216-833-11	METAL CHIP	10K	5%	1/10W	R1466	1-216-821-11	METAL CHIP	1K 5% 1/10W
R1190	1-216-833-11	METAL CHIP	10K	5%	1/10W	R1470	1-218-867-11	METAL CHIP	6.8K 5% 1/10W
R1193	1-216-841-11	METAL CHIP	47K	5%	1/10W	R1471	1-216-864-11	SHORT CHIP	0
R1194	1-216-825-11	METAL CHIP	2.2K	5%	1/10W (AEP, UK, RU)	R1472	1-216-864-11	SHORT CHIP	0
R1194	1-216-829-11	METAL CHIP	4.7K	5%	1/10W (KR, TH, TW, AUS)	R1473	1-218-867-11	METAL CHIP	6.8K 5% 1/10W
R1198	1-216-845-11	METAL CHIP	100K	5%	1/10W	R1474	1-216-833-11	METAL CHIP	10K 5% 1/10W
R1201	1-216-837-11	METAL CHIP	22K	5%	1/10W	R1475	1-216-864-11	SHORT CHIP	0
R1251	1-216-840-11	METAL CHIP	39K	5%	1/10W	R1476	1-216-821-11	METAL CHIP	1K 5% 1/10W
R1252	1-216-840-11	METAL CHIP	39K	5%	1/10W	R1483	1-218-867-11	METAL CHIP	6.8K 5% 1/10W
R1260	1-216-821-11	METAL CHIP	1K	5%	1/10W	R1484	1-216-864-11	SHORT CHIP	0
R1261	1-216-821-11	METAL CHIP	1K	5%	1/10W	R1486	1-216-801-11	METAL CHIP	22 5% 1/10W
R1301	1-216-830-11	METAL CHIP	5.6K	5%	1/10W	R1491	1-218-867-11	METAL CHIP	6.8K 5% 1/10W
R1302	1-216-829-11	METAL CHIP	4.7K	5%	1/10W	R1492	1-218-867-11	METAL CHIP	6.8K 5% 1/10W
R1303	1-216-839-11	METAL CHIP	33K	5%	1/10W	R1493	1-218-867-11	METAL CHIP	6.8K 5% 1/10W
R1304	1-216-809-11	METAL CHIP	100	5%	1/10W	R1494	1-218-867-11	METAL CHIP	6.8K 5% 1/10W
R1305	1-216-819-11	METAL CHIP	680	5%	1/10W	R1495	1-218-867-11	METAL CHIP	6.8K 5% 1/10W
R1306	1-216-801-11	METAL CHIP	22	5%	1/10W	R1501	1-216-809-11	METAL CHIP	100 5% 1/10W
R1307	1-216-809-11	METAL CHIP	100	5%	1/10W	R1502	1-216-809-11	METAL CHIP	100 5% 1/10W
R1308	1-216-809-11	METAL CHIP	100	5%	1/10W	R1503	1-216-813-11	METAL CHIP	220 5% 1/10W
R1309	1-216-809-11	METAL CHIP	100	5%	1/10W	R1504	1-216-809-11	METAL CHIP	100 5% 1/10W
R1310	1-216-857-11	METAL CHIP	1M	5%	1/10W	R1505	1-216-809-11	METAL CHIP	100 5% 1/10W
R1311	1-216-809-11	METAL CHIP	100	5%	1/10W	R1506	1-216-809-11	METAL CHIP	100 5% 1/10W
R1312	1-216-809-11	METAL CHIP	100	5%	1/10W	R1508	1-216-809-11	METAL CHIP	100 5% 1/10W
R1313	1-216-809-11	METAL CHIP	100	5%	1/10W	R1509	1-216-809-11	METAL CHIP	100 5% 1/10W
R1314	1-216-833-11	METAL CHIP	10K	5%	1/10W	R1510	1-216-809-11	METAL CHIP	100 5% 1/10W
R1315	1-216-809-11	METAL CHIP	100	5%	1/10W	R1511	1-216-809-11	METAL CHIP	100 5% 1/10W
R1316	1-216-809-11	METAL CHIP	100	5%	1/10W	R1512	1-216-821-11	METAL CHIP	1K 5% 1/10W
R1318	1-216-833-11	METAL CHIP	10K	5%	1/10W	R1513	1-216-833-11	METAL CHIP	10K 5% 1/10W
R1352	1-216-809-11	METAL CHIP	100	5%	1/10W	R1514	1-216-833-11	METAL CHIP	10K 5% 1/10W
R1353	1-216-809-11	METAL CHIP	100	5%	1/10W	R1515	1-216-857-11	METAL CHIP	1M 5% 1/10W
R1355	1-218-285-11	METAL CHIP	75	5%	1/10W	R1517	1-216-813-11	METAL CHIP	220 5% 1/10W
R1356	1-216-821-11	METAL CHIP	1K	5%	1/10W	R1518	1-216-813-11	METAL CHIP	220 5% 1/10W
R1357	1-216-837-11	METAL CHIP	22K	5%	1/10W	R1519	1-216-813-11	METAL CHIP	220 5% 1/10W
R1358	1-216-854-11	METAL CHIP	560K	5%	1/10W	R1520	1-216-813-11	METAL CHIP	220 5% 1/10W
R1359	1-216-809-11	METAL CHIP	100	5%	1/10W	R1521	1-216-813-11	METAL CHIP	220 5% 1/10W
R1360	1-216-809-11	METAL CHIP	100	5%	1/10W	R1522	1-216-813-11	METAL CHIP	220 5% 1/10W
R1362	1-216-809-11	METAL CHIP	100	5%	1/10W	R1523	1-216-813-11	METAL CHIP	220 5% 1/10W
R1363	1-216-809-11	METAL CHIP	100	5%	1/10W	R1524	1-216-864-11	SHORT CHIP	0
R1401	1-216-821-11	METAL CHIP	1K	5%	1/10W	R1525	1-216-813-11	METAL CHIP	220 5% 1/10W
R1402	1-216-825-11	METAL CHIP	2.2K	5%	1/10W	R1526	1-216-813-11	METAL CHIP	220 5% 1/10W
R1403	1-216-833-11	METAL CHIP	10K	5%	1/10W	R1527	1-216-813-11	METAL CHIP	220 5% 1/10W
R1407	1-216-809-11	METAL CHIP	100	5%	1/10W	R1528	1-216-813-11	METAL CHIP	220 5% 1/10W
R1424	1-218-867-11	METAL CHIP	6.8K	5%	1/10W	R1531	1-216-813-11	METAL CHIP	220 5% 1/10W
R1425	1-216-864-11	SHORT CHIP	0			R1532	1-216-813-11	METAL CHIP	220 5% 1/10W
R1426	1-216-821-11	METAL CHIP	1K	5%	1/10W	R1533	1-216-813-11	METAL CHIP	220 5% 1/10W
R1434	1-218-867-11	METAL CHIP	6.8K	5%	1/10W	R1534	1-216-813-11	METAL CHIP	220 5% 1/10W
R1435	1-216-864-11	SHORT CHIP	0			R1535	1-216-813-11	METAL CHIP	220 5% 1/10W
R1436	1-216-821-11	METAL CHIP	1K	5%	1/10W	R1536	1-216-813-11	METAL CHIP	220 5% 1/10W
R1444	1-218-867-11	METAL CHIP	6.8K	5%	1/10W	R1537	1-216-813-11	METAL CHIP	220 5% 1/10W
R1445	1-216-864-11	SHORT CHIP	0			R1538	1-216-813-11	METAL CHIP	220 5% 1/10W
R1446	1-216-801-11	METAL CHIP	22	5%	1/10W	R1539	1-216-813-11	METAL CHIP	220 5% 1/10W
						R1540	1-216-813-11	METAL CHIP	220 5% 1/10W
						R1541	1-216-813-11	METAL CHIP	220 5% 1/10W
						R1542	1-216-813-11	METAL CHIP	220 5% 1/10W

Ref. No.	Part No.	Description	Remark	Ref. No.	Part No.	Description	Remark
R1543	1-216-813-11	METAL CHIP	220 5% 1/10W			< IC >	
R1544	1-216-813-11	METAL CHIP	220 5% 1/10W				
R1545	1-216-813-11	METAL CHIP	220 5% 1/10W	IC100	8-759-643-83	IC PT6315	
R1546	1-216-813-11	METAL CHIP	220 5% 1/10W	IC101	8-759-243-51	IC TC74ACT08P	
R1547	1-216-813-11	METAL CHIP	220 5% 1/10W	IC102	6-600-309-01	IC RPM7240-H9	
R1548	1-216-813-11	METAL CHIP	220 5% 1/10W			< RESISTOR >	
R1549	1-216-813-11	METAL CHIP	220 5% 1/10W	R101	1-249-409-11	CARBON	220 5% 1/4W
R1550	1-216-813-11	METAL CHIP	220 5% 1/10W	R102	1-249-411-11	CARBON	330 5% 1/4W
R1551	1-216-813-11	METAL CHIP	220 5% 1/10W	R103	1-249-413-11	CARBON	470 5% 1/4W
R1552	1-216-813-11	METAL CHIP	220 5% 1/10W	R104	1-249-415-11	CARBON	680 5% 1/4W
R1553	1-216-813-11	METAL CHIP	220 5% 1/10W	R105	1-247-831-91	CARBON	1K 5% 1/4W
R1554	1-216-813-11	METAL CHIP	220 5% 1/10W	R106	1-249-419-11	CARBON	1.5K 5% 1/4W
R1555	1-216-813-11	METAL CHIP	220 5% 1/10W	R107	1-249-421-11	CARBON	2.2K 5% 1/4W
R1556	1-216-809-11	METAL CHIP	100 5% 1/10W	R108	1-247-847-91	CARBON	4.7K 5% 1/4W
R1570	1-216-833-11	METAL CHIP	10K 5% 1/10W	R111	1-249-409-11	CARBON	220 5% 1/4W
R1571	1-216-833-11	METAL CHIP	10K 5% 1/10W	R112	1-249-411-11	CARBON	330 5% 1/4W
R1572	1-216-833-11	METAL CHIP	10K 5% 1/10W	R113	1-249-413-11	CARBON	470 5% 1/4W
R1573	1-216-833-11	METAL CHIP	10K 5% 1/10W	R114	1-249-415-11	CARBON	680 5% 1/4W
R1574	1-216-833-11	METAL CHIP	10K 5% 1/10W	R116	1-249-419-11	CARBON	1.5K 5% 1/4W
R1635	1-216-825-11	METAL CHIP	2.2K 5% 1/10W	R137	1-249-419-11	CARBON	1.5K 5% 1/4W
R1636	1-216-825-11	METAL CHIP	2.2K 5% 1/10W	R138	1-249-421-11	CARBON	2.2K 5% 1/4W
		< VIBRATOR >		R139	1-247-847-91	CARBON	4.7K 5% 1/4W
X1101	1-813-448-21	PIEZOELECTRIC OSCILLATOR (24MHz)		R150	1-249-440-11	CARBON	82K 5% 1/4W
X1301	1-795-126-21	VIBRATOR, CRYSTAL (12.288MHz)		R153	1-247-807-31	CARBON	100 5% 1/4W
X1502	1-813-276-21	QUARTZ CRYSTAL (13.9MHz)		R172	1-247-807-31	CARBON	100 5% 1/4W

A-1157-676-A		DISPLAY BOARD, COMPLETE		R173	1-247-807-31	CARBON	100 5% 1/4W
		*****		R174	1-247-807-31	CARBON	100 5% 1/4W
		< CAPACITOR >		R175	1-249-393-11	CARBON	10 5% 1/4W
C100	1-135-798-11	CERAMIC	0.22uF 50V	R198	1-249-385-11	CARBON	2.2 5% 1/4W
C101	1-135-798-11	CERAMIC	0.22uF 50V	R199	1-249-385-11	CARBON	2.2 5% 1/4W
C108	1-135-798-11	CERAMIC	0.22uF 50V			< VARIABLE RESISTOR >	
C109	1-135-798-11	CERAMIC	0.22uF 50V	RV102	1-418-725-41	ENCODER, ROTARY (12 TYPE)	(MASTER VOLUME)
C110	1-127-868-11	CERAMIC	2200PF 10% 50V			< SWITCH >	
C111	1-162-282-31	CERAMIC	100PF 10% 50V	S100	1-771-410-21	SWITCH, TACTILE (INPUT MODE)	
C112	1-162-282-31	CERAMIC	100PF 10% 50V	S101	1-771-410-21	SWITCH, TACTILE (>)	
C114	1-135-798-11	CERAMIC	0.22uF 50V	S102	1-771-410-21	SWITCH, TACTILE (v)	
C115	1-124-261-00	ELECT	10uF 20% 50V	S103	1-771-410-21	SWITCH, TACTILE (^)	
C144	1-135-798-11	CERAMIC	0.22uF 50V	S104	1-771-410-21	SWITCH, TACTILE (<)	
C150	1-135-798-11	CERAMIC	0.22uF 50V	S105	1-771-410-21	SWITCH, TACTILE (FM)	
C151	1-124-261-00	ELECT	10uF 20% 50V	S106	1-771-410-21	SWITCH, TACTILE (AM)	
C152	1-162-286-31	CERAMIC	220PF 10% 50V	S107	1-771-410-21	SWITCH, TACTILE (AMP MENU)	
C153	1-162-286-31	CERAMIC	220PF 10% 50V	S108	1-771-410-21	SWITCH, TACTILE (ENTER)	
C154	1-162-286-31	CERAMIC	220PF 10% 50V	S110	1-771-410-21	SWITCH, TACTILE (MUSIC)	
C155	1-135-798-11	CERAMIC	0.22uF 50V	S111	1-771-410-21	SWITCH, TACTILE (MOVIE)	
C156	1-135-798-11	CERAMIC	0.22uF 50V	S112	1-771-410-21	SWITCH, TACTILE (A.F.D.)	
C157	1-135-798-11	CERAMIC	0.22uF 50V	S113	1-771-410-21	SWITCH, TACTILE (2CH)	
		< CONNECTOR >		S116	1-771-410-21	SWITCH, TACTILE (SA-CD/CD)	
CNS100	1-784-780-11	CONNECTOR, FFC 19P		S137	1-771-410-21	SWITCH, TACTILE (VIDEO 1)	
		< FLUORESCENT INDICATOR TUBE >		S138	1-771-410-21	SWITCH, TACTILE (VIDEO 2)	
FL101	1-518-966-11	VOCUUM FLUORESENT DISPLAYS		S139	1-771-410-21	SWITCH, TACTILE (DVD)	

STR-DE400

Ver. 1.2

HEADPHONE **MAIN**

Ref. No.	Part No.	Description	Remark
		HEADPHONE BOARD *****	
		< CONNECTOR >	
CNP701	1-691-766-11	PLUG (MICRO CONNECTOR) 4P	
		< JACK >	
J700	1-815-314-21	JACK (PHONES)	

A-1179-811-A		MAIN BOARD, COMPLETE (EXCEPT TW)	
A-1187-012-A		MAIN BOARD, COMPLETE (TW) *****	
	7-685-646-79	SCREW +BVTP 3X8 TYPE2 IT-3	
		< CAPACITOR >	
C400	1-127-888-11	CERAMIC	0.1uF 10% 50V
C402	1-126-964-11	ELECT	10uF 20% 50V
C403	1-162-294-31	CERAMIC	0.001uF 10% 50V
C404	1-162-294-31	CERAMIC	0.001uF 10% 50V
C405	1-126-963-11	ELECT	4.7uF 20% 50V
C421	1-126-963-11	ELECT	4.7uF 20% 50V
C422	1-126-963-11	ELECT	4.7uF 20% 50V
C423	1-126-963-11	ELECT	4.7uF 20% 50V
C424	1-126-963-11	ELECT	4.7uF 20% 50V
C425	1-126-963-11	ELECT	4.7uF 20% 50V
C426	1-126-963-11	ELECT	4.7uF 20% 50V
C431	1-126-961-11	ELECT	2.2uF 20% 50V
C432	1-126-961-11	ELECT	2.2uF 20% 50V
C433	1-126-961-11	ELECT	2.2uF 20% 50V
C434	1-126-961-11	ELECT	2.2uF 20% 50V
C435	1-126-961-11	ELECT	2.2uF 20% 50V
C436	1-126-961-11	ELECT	2.2uF 20% 50V
C446	1-126-963-11	ELECT	4.7uF 20% 50V
C452	1-126-964-11	ELECT	10uF 20% 50V
C455	1-126-963-11	ELECT	4.7uF 20% 50V
C471	1-104-658-91	ELECT	100uF 20% 10V
C472	1-127-888-11	CERAMIC	0.1uF 10% 50V
C482	1-127-888-11	CERAMIC	0.1uF 10% 50V
C484	1-127-888-11	CERAMIC	0.1uF 10% 50V
C500	1-128-579-11	ELECT	2.2uF 20% 100V (TW)
C501	1-126-963-11	ELECT	4.7uF 20% 50V
C502	1-128-809-11	CERAMIC	100PF 5% 50V
C503	1-128-809-11	CERAMIC	100PF 5% 50V
C504	1-101-810-00	CERAMIC	100PF 5% 500V (TYPE2)
C504	1-102-233-00	CERAMIC	33PF 10% 500V (TYPE1)
C506	1-107-583-11	CERAMIC	3PF 0.25PF 500V
C507	1-104-658-91	ELECT	100uF 20% 10V
C508	1-126-947-11	ELECT	47uF 20% 35V
C511	1-162-815-11	CERAMIC	47PF 5% 500V
C512	1-162-815-11	CERAMIC	47PF 5% 500V
C513	1-128-813-11	CERAMIC	220PF 5% 50V
C514	1-127-876-11	CERAMIC	0.01uF 10% 50V
C515	1-126-964-11	ELECT	10uF 20% 50V
C516	1-136-157-00	FILM	0.022uF 5% 50V
C551	1-126-963-11	ELECT	4.7uF 20% 50V
C552	1-128-809-11	CERAMIC	100PF 5% 50V

Ref. No.	Part No.	Description	Remark
C553	1-128-809-11	CERAMIC	100PF 5% 50V
C554	1-101-810-00	CERAMIC	100PF 5% 500V (TYPE2)
C554	1-102-233-00	CERAMIC	33PF 10% 500V (TYPE1)
C556	1-107-583-11	CERAMIC	3PF 0.25PF 500V
C557	1-104-658-91	ELECT	100uF 20% 10V
C558	1-126-947-11	ELECT	47uF 20% 35V
C561	1-162-815-11	CERAMIC	47PF 5% 500V
C562	1-162-815-11	CERAMIC	47PF 5% 500V
C563	1-128-813-11	CERAMIC	220PF 5% 50V
C564	1-127-876-11	CERAMIC	0.01uF 10% 50V
C565	1-126-964-11	ELECT	10uF 20% 50V
C566	1-136-157-00	FILM	0.022uF 5% 50V
C600	1-128-579-11	ELECT	2.2uF 20% 100V (TW)
C601	1-126-963-11	ELECT	4.7uF 20% 50V
C602	1-128-809-11	CERAMIC	100PF 5% 50V
C603	1-128-809-11	CERAMIC	100PF 5% 50V
C604	1-101-810-00	CERAMIC	100PF 5% 500V (TYPE2)
C604	1-102-233-00	CERAMIC	33PF 10% 500V (TYPE1)
C606	1-107-583-11	CERAMIC	3PF 0.25PF 500V
C607	1-104-658-91	ELECT	100uF 20% 10V
C608	1-126-947-11	ELECT	47uF 20% 35V
C611	1-162-815-11	CERAMIC	47PF 5% 500V
C612	1-162-815-11	CERAMIC	47PF 5% 500V
C613	1-128-813-11	CERAMIC	220PF 5% 50V
C614	1-127-876-11	CERAMIC	0.01uF 10% 50V
C615	1-126-964-11	ELECT	10uF 20% 50V
C616	1-136-157-00	FILM	0.022uF 5% 50V
C651	1-126-963-11	ELECT	4.7uF 20% 50V
C652	1-128-809-11	CERAMIC	100PF 5% 50V
C653	1-128-809-11	CERAMIC	100PF 5% 50V (TYPE2)
C654	1-101-810-00	CERAMIC	100PF 5% 500V (TYPE2)
C654	1-102-233-00	CERAMIC	33PF 10% 500V (TYPE1)
C656	1-107-583-11	CERAMIC	3PF 0.25PF 500V
C657	1-104-658-91	ELECT	100uF 20% 10V
C658	1-126-947-11	ELECT	47uF 20% 35V
C661	1-162-815-11	CERAMIC	47PF 5% 500V
C662	1-162-815-11	CERAMIC	47PF 5% 500V
C663	1-128-813-11	CERAMIC	220PF 5% 50V
C664	1-127-876-11	CERAMIC	0.01uF 10% 50V
C665	1-126-964-11	ELECT	10uF 20% 50V
C666	1-136-157-00	FILM	0.022uF 5% 50V
C700	1-128-579-11	ELECT	2.2uF 20% 100V (TW)
C701	1-126-963-11	ELECT	4.7uF 20% 50V
C702	1-128-809-11	CERAMIC	100PF 5% 50V
C703	1-128-809-11	CERAMIC	100PF 5% 50V
C704	1-101-810-00	CERAMIC	100PF 5% 500V (TYPE2)
C704	1-102-233-00	CERAMIC	33PF 10% 500V (TYPE1)
C706	1-107-583-11	CERAMIC	3PF 0.25PF 500V
C707	1-104-658-91	ELECT	100uF 20% 10V
C708	1-126-947-11	ELECT	47uF 20% 35V
C711	1-162-815-11	CERAMIC	47PF 5% 500V

As for the display of type1 and type2, refer to the SERVICE NOTE "Note on replacement POWER AMPLIFIER IC (page3)".

Ref. No.	Part No.	Description	Remark	Ref. No.	Part No.	Description	Remark
C712	1-162-815-11	CERAMIC	47PF 5% 500V	D703	8-719-991-33	DIODE 1SS133T-72	
C713	1-128-813-11	CERAMIC	220PF 5% 50V	D752	8-719-991-33	DIODE 1SS133T-72	
C714	1-127-876-11	CERAMIC	0.01uF 10% 50V	D791	8-719-991-33	DIODE 1SS133T-72	
C715	1-126-964-11	ELECT	10uF 20% 50V	D801	8-719-933-95	DIODE HZS20-1LTA	
C716	1-136-157-00	FILM	0.022uF 5% 50V	D802	8-719-068-28	DIODE HZ6.8BP-TK	
C801	1-135-798-11	CERAMIC	0.22uF 50V	D804	6-500-522-11	DIODE 10EDB40-TA2B5	
C802	1-135-798-11	CERAMIC	0.22uF 50V	D805	6-500-522-11	DIODE 10EDB40-TA2B5	
C803	1-126-936-11	ELECT	3300uF 20% 16V	D806	6-500-522-11	DIODE 10EDB40-TA2B5	
C806	1-126-947-11	ELECT	47uF 20% 35V	D807	6-500-522-11	DIODE 10EDB40-TA2B5	
C807	1-126-947-11	ELECT	47uF 20% 35V	D811	8-719-072-05	DIODE RBV-602LF-A	
C808	1-126-947-11	ELECT	47uF 20% 35V	D821	8-719-043-76	DIODE AK04V1	
C811	1-135-851-21	MYLAR	0.22uF 100V	D851	8-719-991-33	DIODE 1SS133T-72	
C812	1-135-851-21	MYLAR	0.22uF 100V	D881	8-719-991-33	DIODE 1SS133T-72	
C813	1-100-968-11	ELECT	4700uF 20% 63V	D882	8-719-991-33	DIODE 1SS133T-72	
C814	1-100-968-11	ELECT	4700uF 20% 63V	D883	8-719-991-33	DIODE 1SS133T-72	
C815	1-128-582-11	ELECT	10uF 20% 100V			< IC >	
C816	1-128-582-11	ELECT	10uF 20% 100V	IC400	6-707-169-01	IC M61542FP	
C821	1-127-888-11	CERAMIC	0.1uF 10% 50V	IC501	6-600-450-01	IC STK350-530-E (TYPE1)	
C822	1-127-888-11	CERAMIC	0.1uF 10% 50V	IC501	6-710-828-01	IC STK350-530T-E (TYPE2)	
C823	1-126-947-11	ELECT	47uF 20% 35V	IC601	6-600-450-01	IC STK350-530-E (TYPE1)	
C824	1-126-947-11	ELECT	47uF 20% 35V	IC601	6-710-828-01	IC STK350-530T-E (TYPE2)	
C851	1-127-888-11	CERAMIC	0.1uF 10% 50V	IC701	6-600-450-01	IC STK350-530-E (TYPE1)	
C881	1-126-934-11	ELECT	220uF 20% 16V	IC701	6-710-828-01	IC STK350-530T-E (TYPE2)	
C882	1-126-964-11	ELECT	10uF 20% 50V	IC821	8-759-071-48	IC TA7807S	
CC01	1-128-809-11	CERAMIC	100PF 5% 50V	IC822	8-759-071-47	IC TA79007S	
CC02	1-128-809-11	CERAMIC	100PF 5% 50V	IC850	8-759-167-88	IC NJM4565D	
CC03	1-128-809-11	CERAMIC	100PF 5% 50V			< JACK >	
CC04	1-128-809-11	CERAMIC	100PF 5% 50V	J400	1-774-411-11	JACK, PIN 6P (AUDIO IN//VIDEO 2/DVD/SA-CD/CD)	
CC11	1-127-876-11	CERAMIC	0.01uF 10% 50V	J401	1-794-981-11	JACK, PIN 4P (AUDIO IN/AUDIO OUT//VIDEO 1)	
CC12	1-127-876-11	CERAMIC	0.01uF 10% 50V	J403	1-770-377-21	JACK, PIN 1P (AUDIO OUT/SUB WOOFER)	
CC13	1-127-876-11	CERAMIC	0.01uF 10% 50V			< JUMPER RESISTOR >	
CC14	1-127-876-11	CERAMIC	0.01uF 10% 50V	JW753	1-247-873-91	CARBON 56K 5% 1/4W	
CC15	1-127-876-11	CERAMIC	0.01uF 10% 50V			< TRANSISTOR >	
CC51	1-128-809-11	CERAMIC	100PF 5% 50V	Q471	8-729-922-37	TRANSISTOR 2SD2144S-TP-UVW	
CC52	1-128-809-11	CERAMIC	100PF 5% 50V	Q501	8-729-119-76	TRANSISTOR 2SA1115TP-EF	
CC53	1-128-809-11	CERAMIC	100PF 5% 50V	Q502	8-729-141-30	TRANSISTOR 2SC3623ATP-LK	
CC54	1-128-809-11	CERAMIC	100PF 5% 50V	Q505	8-729-042-09	TRANSISTOR 2SA1038S-RSE-TP	
		< CONNECTOR >		Q506	8-729-042-09	TRANSISTOR 2SA1038S-RSE-TP	
CN504	1-779-978-11	PIN, CONNECTOR 3P		Q507	8-729-281-53	TRANSISTOR 2SC1815GR-TPE2	
CNP501	1-573-847-11	CONNECTOR, BOARD TO BOARD 15P		Q508	8-729-119-78	TRANSISTOR 2SC1740S-QRT	
* CNP502	1-766-715-11	CONNECTOR, BOARD TO BOARD 10P		Q509	8-729-119-78	TRANSISTOR 2SC1740S-QRT	
* CNP503	1-779-799-11	PIN, CONNECTOR 9P		Q551	8-729-119-76	TRANSISTOR 2SA1115TP-EF	
* CNP901	1-564-104-00	PIN, CONNECTOR (3.96mm PITCH) 3P		Q552	8-729-141-30	TRANSISTOR 2SC3623ATP-LK	
CNP902	1-691-767-11	PLUG (MICRO CONNECTOR) 5P		Q555	8-729-042-09	TRANSISTOR 2SA1038S-RSE-TP	
CNP916	1-766-200-11	SOCKET, CONNECTOR PIN 5P		Q556	8-729-042-09	TRANSISTOR 2SA1038S-RSE-TP	
		< DIODE >		Q557	8-729-281-53	TRANSISTOR 2SC1815GR-TPE2	
D501	8-719-991-33	DIODE 1SS133T-72		Q560	8-729-119-78	TRANSISTOR 2SC1740S-QRT	
D502	8-719-991-33	DIODE 1SS133T-72		Q601	8-729-119-76	TRANSISTOR 2SA1115TP-EF	
D503	8-719-991-33	DIODE 1SS133T-72		Q602	8-729-141-30	TRANSISTOR 2SC3623ATP-LK	
D551	8-719-991-33	DIODE 1SS133T-72		Q605	8-729-042-09	TRANSISTOR 2SA1038S-RSE-TP	
D552	8-719-991-33	DIODE 1SS133T-72		Q606	8-729-042-09	TRANSISTOR 2SA1038S-RSE-TP	
D601	8-719-991-33	DIODE 1SS133T-72		Q607	8-729-281-53	TRANSISTOR 2SC1815GR-TPE2	
D602	8-719-991-33	DIODE 1SS133T-72		Q608	8-729-119-78	TRANSISTOR 2SC1740S-QRT	
D603	8-719-991-33	DIODE 1SS133T-72					
D651	8-719-991-33	DIODE 1SS133T-72					
D652	8-719-991-33	DIODE 1SS133T-72					
D701	8-719-991-33	DIODE 1SS133T-72					
D702	8-719-991-33	DIODE 1SS133T-72					

When replacing the POWER AMPLIFIER IC (IC501, 601, 701), refer to SERVICE NOTE "Note on replacement POWER AMPLIFIER IC" (page3).

STR-DE400

Ver. 1.2

MAIN

Ref. No.	Part No.	Description	Remark	Ref. No.	Part No.	Description	Remark
Q651	8-729-119-76	TRANSISTOR	2SA1115TP-EF	△R521	1-249-393-11	CARBON	10 5% 1/4W
Q652	8-729-141-30	TRANSISTOR	2SC3623ATP-LK	R522	1-247-871-91	CARBON	47K 5% 1/4W
Q655	8-729-042-09	TRANSISTOR	2SA1038S-RSE-TP	△R524	1-249-404-00	CARBON	82 5% 1/4W
Q656	8-729-042-09	TRANSISTOR	2SA1038S-RSE-TP	R525	1-249-421-11	CARBON	2.2K 5% 1/4W
Q657	8-729-281-53	TRANSISTOR	2SC1815GR-TPE2	R531	1-215-868-00	METAL OXIDE	680 5% 1W
Q701	8-729-119-76	TRANSISTOR	2SA1115TP-EF	R532	1-215-868-00	METAL OXIDE	680 5% 1W
Q702	8-729-141-30	TRANSISTOR	2SC3623ATP-LK	△R551	1-247-831-91	CARBON	1K 5% 1/4W
Q705	8-729-042-09	TRANSISTOR	2SA1038S-RSE-TP	R552	1-249-439-11	CARBON	68K 5% 1/4W
Q706	8-729-042-09	TRANSISTOR	2SA1038S-RSE-TP	R553	1-249-422-11	CARBON	2.7K 5% 1/4W
Q707	8-729-281-53	TRANSISTOR	2SC1815GR-TPE2	R554	1-249-439-11	CARBON	68K 5% 1/4W
Q708	8-729-119-78	TRANSISTOR	2SC1740S-QRT	R555	1-249-421-11	CARBON	2.2K 5% 1/4W
Q801	8-729-140-97	TRANSISTOR	2SB734-T-34	R556	1-249-440-11	CARBON	82K 5% 1/4W
Q851	8-729-281-53	TRANSISTOR	2SC1815GR-TPE2	R557	1-249-414-11	CARBON	560 5% 1/4W
Q852	8-729-029-40	TRANSISTOR	DTA124ESA-TP	△R558	1-249-405-11	CARBON	100 5% 1/4W
Q881	8-729-042-09	TRANSISTOR	2SA1038S-RSE-TP	△R559	1-249-405-11	CARBON	100 5% 1/4W
Q882	8-729-119-78	TRANSISTOR	2SC1740S-QRT	△R560	1-234-182-11	ENCAPSULATED COMPONENT	
Q883	8-729-140-84	TRANSISTOR	2SC1841TP-PAFAEA	R561	1-247-847-91	CARBON	4.7K 5% 1/4W
		< RESISTOR >		△R562	1-240-855-81	CARBON	6.2K 5% 1/4W
R401	1-247-831-91	CARBON	1K 5% 1/4W	R563	1-249-419-11	CARBON	1.5K 5% 1/4W
R402	1-247-831-91	CARBON	1K 5% 1/4W	R564	1-249-431-11	CARBON	15K 5% 1/4W
R403	1-247-831-91	CARBON	1K 5% 1/4W	R565	1-247-863-91	CARBON	22K 5% 1/4W
R404	1-247-831-91	CARBON	1K 5% 1/4W	R566	1-247-843-11	CARBON	3.3K 5% 1/4W
R405	1-247-831-91	CARBON	1K 5% 1/4W	R567	1-249-431-11	CARBON	15K 5% 1/4W
R406	1-247-807-31	CARBON	100 5% 1/4W	R568	1-247-863-91	CARBON	22K 5% 1/4W
R407	1-247-807-31	CARBON	100 5% 1/4W	R569	1-247-863-91	CARBON	22K 5% 1/4W
R416	1-247-831-91	CARBON	1K 5% 1/4W	R570	1-249-439-11	CARBON	68K 5% 1/4W
R451	1-247-831-91	CARBON	1K 5% 1/4W	△R571	1-249-393-11	CARBON	10 5% 1/4W
R452	1-247-831-91	CARBON	1K 5% 1/4W	R572	1-247-871-91	CARBON	47K 5% 1/4W
R453	1-247-831-91	CARBON	1K 5% 1/4W	R600	1-247-871-91	CARBON	47K 5% 1/4W
R454	1-247-831-91	CARBON	1K 5% 1/4W				(TW)
R455	1-247-831-91	CARBON	1K 5% 1/4W	R601	1-247-831-91	CARBON	1K 5% 1/4W
R469	1-247-831-91	CARBON	1K 5% 1/4W	R602	1-249-439-11	CARBON	68K 5% 1/4W
R471	1-249-415-11	CARBON	680 5% 1/4W	R603	1-249-422-11	CARBON	2.7K 5% 1/4W
R472	1-247-831-91	CARBON	1K 5% 1/4W	R604	1-249-439-11	CARBON	68K 5% 1/4W
R473	1-249-421-11	CARBON	2.2K 5% 1/4W	R605	1-249-421-11	CARBON	2.2K 5% 1/4W
R479	1-249-421-11	CARBON	2.2K 5% 1/4W	R606	1-249-440-11	CARBON	82K 5% 1/4W
R500	1-247-871-91	CARBON	47K 5% 1/4W	R607	1-249-414-11	CARBON	560 5% 1/4W
R501	1-247-831-91	CARBON	1K 5% 1/4W	△R608	1-249-405-11	CARBON	100 5% 1/4W
R502	1-249-439-11	CARBON	68K 5% 1/4W	△R609	1-249-405-11	CARBON	100 5% 1/4W
R503	1-249-422-11	CARBON	2.7K 5% 1/4W	△R610	1-234-182-11	ENCAPSULATED COMPONENT	
R504	1-249-439-11	CARBON	68K 5% 1/4W	R611	1-247-847-91	CARBON	4.7K 5% 1/4W
R505	1-249-421-11	CARBON	2.2K 5% 1/4W	△R612	1-240-855-81	CARBON	6.2K 5% 1/4W
R506	1-249-440-11	CARBON	82K 5% 1/4W	R613	1-249-419-11	CARBON	1.5K 5% 1/4W
R507	1-249-414-11	CARBON	560 5% 1/4W	R614	1-249-431-11	CARBON	15K 5% 1/4W
△R508	1-249-405-11	CARBON	100 5% 1/4W	R615	1-247-863-91	CARBON	22K 5% 1/4W
△R509	1-249-405-11	CARBON	100 5% 1/4W	R616	1-247-843-11	CARBON	3.3K 5% 1/4W
△R510	1-234-182-11	ENCAPSULATED COMPONENT		R617	1-249-431-11	CARBON	15K 5% 1/4W
R511	1-247-847-91	CARBON	4.7K 5% 1/4W	R618	1-247-863-91	CARBON	22K 5% 1/4W
△R512	1-240-855-81	CARBON	6.2K 5% 1/4W	R619	1-247-863-91	CARBON	22K 5% 1/4W
R513	1-249-419-11	CARBON	1.5K 5% 1/4W	R620	1-249-439-11	CARBON	68K 5% 1/4W
R514	1-249-431-11	CARBON	15K 5% 1/4W	△R621	1-249-393-11	CARBON	10 5% 1/4W
R515	1-247-863-91	CARBON	22K 5% 1/4W	R622	1-247-871-91	CARBON	47K 5% 1/4W
R516	1-247-843-11	CARBON	3.3K 5% 1/4W	△R624	1-249-404-00	CARBON	82 5% 1/4W
R517	1-249-431-11	CARBON	15K 5% 1/4W	R625	1-249-421-11	CARBON	2.2K 5% 1/4W
R518	1-247-863-91	CARBON	22K 5% 1/4W	R651	1-247-831-91	CARBON	1K 5% 1/4W
R519	1-247-863-91	CARBON	22K 5% 1/4W	R652	1-249-439-11	CARBON	68K 5% 1/4W
R520	1-249-439-11	CARBON	68K 5% 1/4W	R653	1-249-422-11	CARBON	2.7K 5% 1/4W
				R654	1-249-439-11	CARBON	68K 5% 1/4W

MAIN

POWER

STANDBY

Ref. No.	Part No.	Description	Remark	Ref. No.	Part No.	Description	Remark
R655	1-249-421-11	CARBON	2.2K 5%	1/4W	R856	1-247-895-00	CARBON 470K 5% 1/4W
R656	1-249-440-11	CARBON	82K 5%	1/4W	R857	1-249-429-11	CARBON 10K 5% 1/4W
R657	1-249-414-11	CARBON	560 5%	1/4W	R858	1-215-889-00	METAL OXIDE 330 5% 2W
△R658	1-249-405-11	CARBON	100 5%	1/4W	R859	1-216-453-00	METAL OXIDE 270 5% 2W
△R659	1-249-405-11	CARBON	100 5%	1/4W	R881	1-247-871-91	CARBON 47K 5% 1/4W
△R660	1-234-182-11	ENCAPSULATED COMPONENT			R882	1-249-429-11	CARBON 10K 5% 1/4W
R661	1-247-847-91	CARBON	4.7K 5%	1/4W	R883	1-249-427-11	CARBON 6.8K 5% 1/4W
△R662	1-240-855-81	CARBON	6.2K 5%	1/4W	R884	1-249-436-11	CARBON 39K 5% 1/4W
R663	1-249-419-11	CARBON	1.5K 5%	1/4W	R885	1-247-831-91	CARBON 1K 5% 1/4W
R664	1-249-431-11	CARBON	15K 5%	1/4W	△R910	1-243-635-11	FUSIBLE 0.33 5% 1/2W
R665	1-247-863-91	CARBON	22K 5%	1/4W	△RR11	1-249-393-11	CARBON 10 5% 1/4W
R666	1-247-843-11	CARBON	3.3K 5%	1/4W	△RR12	1-249-393-11	CARBON 10 5% 1/4W
R667	1-249-431-11	CARBON	15K 5%	1/4W	△RR13	1-249-393-11	CARBON 10 5% 1/4W
R668	1-247-863-91	CARBON	22K 5%	1/4W	△RR14	1-249-393-11	CARBON 10 5% 1/4W
R669	1-247-863-91	CARBON	22K 5%	1/4W	△RR15	1-249-393-11	CARBON 10 5% 1/4W
R670	1-249-439-11	CARBON	68K 5%	1/4W			< RELAY >
△R671	1-249-393-11	CARBON	10 5%	1/4W	RY501	1-755-416-12	RELAY
R672	1-247-871-91	CARBON	47K 5%	1/4W	RY502	1-755-416-12	RELAY
R700	1-247-871-91	CARBON	47K 5%	1/4W	RY601	1-755-416-12	RELAY
				(TW)	RY701	1-755-416-12	RELAY
R701	1-247-831-91	CARBON	1K 5%	1/4W	RY702	1-755-267-11	RELAY
R702	1-249-439-11	CARBON	68K 5%	1/4W			< TERMINAL >
R703	1-249-422-11	CARBON	2.7K 5%	1/4W	TM600	1-694-805-11	TERMINAL BOARD
R704	1-249-439-11	CARBON	68K 5%	1/4W			(FRONT/CENTER//SPEAKERS IMPEDANCE 6-16Ω)
R705	1-249-421-11	CARBON	2.2K 5%	1/4W	TM602	1-694-785-11	TERMINAL BOARD
R706	1-249-440-11	CARBON	82K 5%	1/4W			(SURROUND/SPEAKERS IMPEDANCE 6-16Ω)
R707	1-249-414-11	CARBON	560 5%	1/4W			*****
△R708	1-249-405-11	CARBON	100 5%	1/4W			POWER BOARD
△R709	1-249-405-11	CARBON	100 5%	1/4W			*****
△R710	1-234-182-11	ENCAPSULATED COMPONENT					< RESISTOR >
R711	1-247-847-91	CARBON	4.7K 5%	1/4W	R115	1-247-831-91	CARBON 1K 5% 1/4W
△R712	1-240-855-81	CARBON	6.2K 5%	1/4W			< SWITCH >
R713	1-249-419-11	CARBON	1.5K 5%	1/4W	S114	1-771-410-21	SWITCH, TACTILE (DISPLAY)
R714	1-249-431-11	CARBON	15K 5%	1/4W	S115	1-771-410-21	SWITCH, TACTILE (DIMMER)
R715	1-247-863-91	CARBON	22K 5%	1/4W	S152	1-771-410-21	SWITCH, TACTILE (I/⏻)
R716	1-247-843-11	CARBON	3.3K 5%	1/4W			*****
R717	1-249-431-11	CARBON	15K 5%	1/4W	A-1157-640-A	STANDBY BOARD, COMPLETE	
R718	1-247-863-91	CARBON	22K 5%	1/4W			(AEP, UK, RU, AUS)
R719	1-247-863-91	CARBON	22K 5%	1/4W	A-1185-845-A	STANDBY BOARD, COMPLETE (KR)	
R720	1-249-439-11	CARBON	68K 5%	1/4W	A-1185-846-A	STANDBY BOARD, COMPLETE (TW)	
△R721	1-249-393-11	CARBON	10 5%	1/4W	A-1185-847-A	STANDBY BOARD, COMPLETE (TH)	
R722	1-247-871-91	CARBON	47K 5%	1/4W			*****
△R724	1-249-404-00	CARBON	82 5%	1/4W			< CAPACITOR >
R725	1-249-421-11	CARBON	2.2K 5%	1/4W	C901	1-135-798-11	CERAMIC 0.22uF 50V
R752	1-247-873-91	CARBON	56K 5%	1/4W	C902	1-135-798-11	CERAMIC 0.22uF 50V
R780	1-247-847-91	CARBON	4.7K 5%	1/4W	C911	1-135-798-11	CERAMIC 0.22uF 50V
R782	1-247-879-91	CARBON	100K 5%	1/4W	C912	1-135-798-11	CERAMIC 0.22uF 50V
△R783	1-247-871-91	CARBON	47K 5%	1/4W	C913	1-126-959-11	ELECT 0.47uF 20% 50V
R791	1-249-421-11	CARBON	2.2K 5%	1/4W	C914	1-126-936-11	ELECT 3300uF 20% 16V
R793	1-249-404-00	CARBON	82 5%	1/4W	C915	1-126-943-11	ELECT 2200uF 20% 25V
△R802	1-249-409-11	CARBON	220 5%	1/4W	C916	1-126-942-61	ELECT 1000uF 20% 25V
△R803	1-249-389-11	CARBON	4.7 5%	1/4W			< CONNECTOR >
R804	1-249-429-11	CARBON	10K 5%	1/4W	CNP801	1-784-922-11	PIN, CONNECTOR 5P
R806	1-247-863-91	CARBON	22K 5%	1/4W	CNP900	1-564-321-00	PIN, CONNECTOR (3.96mm PITCH) 2P
△R816	1-249-381-11	CARBON	1 5%	1/4W			
R851	1-249-429-11	CARBON	10K 5%	1/4W			
R852	1-249-429-11	CARBON	10K 5%	1/4W			
R853	1-249-429-11	CARBON	10K 5%	1/4W			
R854	1-249-435-11	CARBON	33K 5%	1/4W			
R855	1-247-887-00	CARBON	220K 5%	1/4W			

STR-DE400

Ver. 1.2

STANDBY **TUNING** **VIDEO**

Ref. No.	Part No.	Description	Remark
CNP903	1-564-506-11	PLUG, CONNECTOR 3P	
CNP904	1-794-577-21	PIN, CONNECTOR (POWER)	
CNP906	1-766-203-11	PLUG, CONNECTOR PIN (PC BOARD) 5P	
< DIODE >			
D901	8-719-991-33	DIODE 1SS133T-72	
D910	6-500-522-11	DIODE 10EDB40-TA2B5	
D911	6-500-522-11	DIODE 10EDB40-TA2B5	
D912	6-500-522-11	DIODE 10EDB40-TA2B5	
D913	6-500-522-11	DIODE 10EDB40-TA2B5	
D914	8-719-991-33	DIODE 1SS133T-72	
D915	8-719-991-33	DIODE 1SS133T-72	
D920	6-500-522-11	DIODE 10EDB40-TA2B5	
D921	6-500-522-11	DIODE 10EDB40-TA2B5	
D922	6-500-522-11	DIODE 10EDB40-TA2B5	
D923	6-500-522-11	DIODE 10EDB40-TA2B5	
< FUSE HOLDER >			
FH902	1-533-217-41	HOLDER, FUSE	
FH952	1-533-217-41	HOLDER, FUSE	
< TRANSISTOR >			
Q901	8-729-119-78	TRANSISTOR 2SC1740S-QRT	
Q911	8-729-119-78	TRANSISTOR 2SC1740S-QRT	
< RESISTOR >			
△R810	1-243-634-91	FUSIBLE 0.22 5% 1/2W	
△R812	1-243-634-91	FUSIBLE 0.22 5% 1/2W	
R903	1-247-871-91	CARBON 47K 5% 1/4W	
R904	1-247-847-91	CARBON 4.7K 5% 1/4W	
△R905	1-249-381-11	CARBON 1 5% 1/4W	
R911	1-247-871-91	CARBON 47K 5% 1/4W	
R912	1-249-435-11	CARBON 33K 5% 1/4W	
R913	1-249-429-11	CARBON 10K 5% 1/4W	
< RELAY >			
△RY901	1-755-439-11	RELAY	
< POWER TRANSFORMER >			
△TP900	1-443-517-11	POWER TRANSFORMER (EXCEPT TW)	
△TP900	1-443-519-11	POWER TRANSFORMER (TW)	

TUNING BOARD *****			
< RESISTOR >			
R132	1-249-409-11	CARBON 220 5% 1/4W	
R133	1-249-411-11	CARBON 330 5% 1/4W	
R134	1-249-413-11	CARBON 470 5% 1/4W	
R135	1-249-415-11	CARBON 680 5% 1/4W	
R136	1-247-831-91	CARBON 1K 5% 1/4W	
< SWITCH >			
S131	1-771-410-21	SWITCH, TACTILE (-/TUNING)	
S132	1-771-410-21	SWITCH, TACTILE (FM MODE)	
S133	1-771-410-21	SWITCH, TACTILE (MEMORY)	
S134	1-771-410-21	SWITCH, TACTILE (-/PRESET TUNING)	
S135	1-771-410-21	SWITCH, TACTILE (+/PRESET TUNING)	

Ref. No.	Part No.	Description	Remark
S136	1-771-410-21	SWITCH, TACTILE (+/TUNING)	

VIDEO BOARD *****			
< CAPACITOR >			
C200	1-128-805-11	CERAMIC 47PF 5% 50V	
C201	1-128-805-11	CERAMIC 47PF 5% 50V	
C206	1-126-964-11	ELECT 10uF 20% 50V	
C207	1-126-964-11	ELECT 10uF 20% 50V	
C208	1-126-964-11	ELECT 10uF 20% 50V	
C210	1-126-964-11	ELECT 10uF 20% 50V	
C213	1-126-934-11	ELECT 220uF 20% 16V	
C214	1-164-159-11	CERAMIC 0.1uF 50V	
C215	1-164-159-11	CERAMIC 0.1uF 50V	
C248	1-128-825-11	CERAMIC 2200PF 5% 50V	
C250	1-128-825-11	CERAMIC 2200PF 5% 50V	
C251	1-126-964-11	ELECT 10uF 20% 50V	
C252	1-126-964-11	ELECT 10uF 20% 50V	
C253	1-126-964-11	ELECT 10uF 20% 50V	
C254	1-126-964-11	ELECT 10uF 20% 50V	
C255	1-126-964-11	ELECT 10uF 20% 50V	
C256	1-126-964-11	ELECT 10uF 20% 50V	
C257	1-127-888-11	CERAMIC 0.1uF 10% 50V	
C258	1-126-947-11	ELECT 47uF 20% 35V	
C259	1-127-888-11	CERAMIC 0.1uF 10% 50V	
C260	1-126-947-11	ELECT 47uF 20% 35V	
C809	1-126-934-11	ELECT 220uF 20% 16V	
C825	1-164-159-11	CERAMIC 0.1uF 50V	
C826	1-164-159-11	CERAMIC 0.1uF 50V	
< CONNECTOR >			
CNP156	1-691-765-11	PLUG (MICRO CONNECTOR) 3P	
CNS250	1-784-766-11	CONNECTOR, FFC 5P	
< IC >			
IC203	8-759-333-84	IC NJM2279D	
IC251	6-707-363-01	IC NJM2586AL	
IC804	8-759-245-79	IC TA79005S	
IC807	8-759-231-53	IC TA7805S	
< JACK >			
J201	1-815-043-11	JACK, PIN 2P (VIDEO IN/VIDEO 1//VIDEO OUT/MONITOR)	
J202	1-794-978-11	JACK, PIN 3P (VIDEO IN/DVD//VIDEO IN/VIDEO 2//VIDEO OUT/VIDEO 1)	
J251	1-816-592-11	JACK, PIN 9P (MONITOR OUT/VIDEO 2 IN/DVD IN//COMPONENT VIDEO)	
< RESISTOR >			
R200	1-247-804-11	CARBON 75 5% 1/4W	
R201	1-247-804-11	CARBON 75 5% 1/4W	
R218	1-247-804-11	CARBON 75 5% 1/4W	
R220	1-247-804-11	CARBON 75 5% 1/4W	
R221	1-247-804-11	CARBON 75 5% 1/4W	
R250	1-247-804-11	CARBON 75 5% 1/4W	
R251	1-247-804-11	CARBON 75 5% 1/4W	

Ref. No.	Part No.	Description	Remark	Ref. No.	Part No.	Description	Remark
R252	1-247-804-11	CARBON	75 5% 1/4W	2-680-009-61	INSTRUCTION MANUAL		
R253	1-247-831-91	CARBON	1K 5% 1/4W		(TRADITIONAL CHINESE)(TH, TW)		
R254	1-247-831-91	CARBON	1K 5% 1/4W	2-680-009-71	INSTRUCTION MANUAL (KOREAN)(KR)		
R255	1-247-831-91	CARBON	1K 5% 1/4W	2-680-009-81	INSTRUCTION MANUAL (RUSSIAN)(RU)		
R256	1-247-804-11	CARBON	75 5% 1/4W	2-682-281-11	INSTRUCTION MANUAL (DANISH, FINNISH)		(AEP)
R257	1-247-804-11	CARBON	75 5% 1/4W	2-682-281-21	INSTRUCTION MANUAL (PORTUGUESE)(AEP)		
R258	1-247-804-11	CARBON	75 5% 1/4W	2-682-281-31	INSTRUCTION MANUAL (RUSSIAN)(AEP)		
R259	1-247-804-11	CARBON	75 5% 1/4W	2-682-281-41	INSTRUCTION MANUAL (GREEK)(AEP)		
R260	1-247-804-11	CARBON	75 5% 1/4W	2-682-281-51	INSTRUCTION MANUAL (TURKISH)(AEP)		
R261	1-247-804-11	CARBON	75 5% 1/4W	2-682-281-61	INSTRUCTION MANUAL (HUNGARIAN, CZECH)		(AEP)
R262	1-247-863-91	CARBON	22K 5% 1/4W	2-682-281-71	INSTRUCTION MANUAL (SLOVAK)(AEP)		

MISCELLANEOUS							

8	1-829-004-11	WIRE (FLAT TYPE) (19 CORE)					
△ 59	1-696-847-11	CORD, POWER (AUS)					
△ 59	1-769-079-23	CORD, POWER (KR)					
△ 59	1-777-071-82	CORD, POWER (AEP, UK, RU, TH)					
△ 59	1-827-597-41	CORD, POWER (TW)					
61	1-828-963-11	WIRE (FLAT TYPE) (11 CORE)					
		(KR, TH, TW, AUS)					
61	1-828-980-11	WIRE (FLAT TYPE) (15 CORE) (AEP, UK, RU)					
62	1-828-936-11	WIRE (FLAT TYPE) (5 CORE)					
△ F901	1-532-464-33	FUSE (T2.5AL/250V) (EXCEPT TW)					
△ F901	1-532-504-33	FUSE, TIME-LAG (T4A/250V) (TW)					
Q503	6-702-390-01	IC MN2488-OPY-MK					
Q504	6-702-391-01	IC MP1620-OPY-MK					
Q553	6-702-390-01	IC MN2488-OPY-MK					
Q554	6-702-391-01	IC MP1620-OPY-MK					
Q603	6-702-390-01	IC MN2488-OPY-MK					
Q604	6-702-391-01	IC MP1620-OPY-MK					
Q653	6-702-390-01	IC MN2488-OPY-MK					
Q654	6-702-391-01	IC MP1620-OPY-MK					
Q703	6-702-390-01	IC MN2488-OPY-MK					
Q704	6-702-391-01	IC MP1620-OPY-MK					
△ T901	1-443-916-11	POWER TRANSFORMER (EXCEPT TH, TW)					
△ T901	1-443-918-11	POWER TRANSFORMER (TH)					
△ T901	1-445-030-11	POWER TRANSFORMER (TW)					
TN1	1-693-676-21	TUNER (AEP, UK, RU)					
TN1	1-693-678-11	TUNER (KR, TH, TW, AUS)					

ACCESSORIES							

	1-479-692-11	STANDARD COMMANDER (RM-AAU006)					
		(Including Battery Cover)					
	1-501-374-12	ANTENNA, LOOP (AM)					
	1-501-807-12	ANTENNA (FM)					
	1-542-670-11	MEASUREMENT MIC (MONO)(ECM-AC2)					
△	1-770-019-61	ADAPTOR, CONVERSION PLUG (UK)					
	2-680-009-11	INSTRUCTION MANUAL (ENGLISH)					
		(EXCEPT RU, KR)					
	2-680-009-21	INSTRUCTION MANUAL (FRENCH)(AEP, TH)					
	2-680-009-31	INSTRUCTION MANUAL (SPANISH)(AEP, TH)					
	2-680-009-41	INSTRUCTION MANUAL					
		(GERMAN, DUTCH, SWEDISH)(AEP)					
	2-680-009-51	INSTRUCTION MANUAL (ITALIAN, POLISH)					
		(AEP)					

