



North/ Latin America  
Europe/Africa  
Asia/Oceania

Internal Use Only

<http://aic.lgservice.com>  
<http://eic.lgservice.com>  
<http://biz.lgservice.com>



# COLOR TV SERVICE MANUAL

CHASSIS : CW81B

MODEL : 21FU6PL/RL/RLX/RG/  
TL/TLG/TG/RLG

21FU6PL/RL/RLX/RG/

TL/TLG/TG/RLG-T4/Z4

## CAUTION

BEFORE SERVICING THE CHASSIS,  
READ THE SAFETY PRECAUTIONS IN THIS MANUAL.



P/NO : MFL42115601

Oct., 2008  
Printed in China

# CONTENTS

<b>CONTENTS .....</b>	<b>2</b>
<b>SAFETY PRECAUTIONS.....</b>	<b>3</b>
<b>SPECIFICATIONS .....</b>	<b>4</b>
<b>ADJUSTMENT .....</b>	<b>6</b>
<b>TROUBLE SHOOTING .....</b>	<b>14</b>
<b>BLOCK DIAGRAM .....</b>	<b>18</b>
<b>PRINTED CIRCUIT BOARD .....</b>	<b>19</b>
<b>EXPLODED VIEW .....</b>	<b>21</b>

# SAFETY PRECAUTIONS

## IMPORTANT SAFETY NOTICE

Many electrical and mechanical parts in this chassis have special safety-related characteristics. These parts are identified by  $\Delta$  in the Schematic Diagram and Replacement Parts List. It is essential that these special safety parts should be replaced with the same components as recommended in this manual to prevent X-RADIATION, Shock, Fire, or other Hazards. Do not modify the original design without permission of manufacturer.

### General Guidance

An **isolation Transformer should always be used** during the servicing of a receiver whose chassis is not isolated from the AC power line. Use a transformer of adequate power rating as this protects the technician from accidents resulting in personal injury from electrical shocks.

It will also protect the receiver and its components from being damaged by accidental shorts of the circuitry that may be inadvertently introduced during the service operation.

If any fuse (or Fusible Resistor) in this TV receiver is blown, replace it with the specified.

When replacing a high wattage resistor (Oxide Metal Film Resistor, over 1W), keep the resistor 10mm away from PCB.

Keep wires away from high voltage or high temperature parts.

Due to high vacuum and large surface area of picture tube, extreme care should be used in **handling the Picture Tube**. Do not lift the Picture tube by its Neck.

### X-RAY Radiation

#### Warning:

The source of X-RAY RADIATION in this TV receiver is the High Voltage Section and the Picture Tube. For continued X-RAY RADIATION protection, the replacement tube must be the same type tube as specified in the Replacement Parts List.

To determine the presence of high voltage, use an accurate high impedance HV meter.

Adjust brightness, color, contrast controls to minimum.

Measure the high voltage.

The meter reading should indicate

23.5  $\pm$  1.5KV: 14-19 inch, 26  $\pm$  1.5KV: 19-21 inch,

29.0  $\pm$  1.5KV: 25-29 inch, 30.0  $\pm$  1.5KV: 32 inch

If the meter indication is out of tolerance, immediate service and correction is required to prevent the possibility of premature component failure.

### Before returning the receiver to the customer,

always perform an **AC leakage current check** on the exposed metallic parts of the cabinet, such as antennas, terminals, etc., to be sure the set is safe to operate without damage of electrical shock.

#### Leakage Current Cold Check(Antenna Cold Check)

With the instrument AC plug removed from AC source, connect an electrical jumper across the two AC plug prongs. Place the AC switch in the on position, connect one lead of ohm-meter to the AC plug prongs tied together and touch other ohm-meter lead in turn to each exposed metallic parts such as antenna terminals, phone jacks, etc.

If the exposed metallic part has a return path to the chassis, the measured resistance should be between 1M $\Omega$  and 5.2M $\Omega$ .

When the exposed metal has no return path to the chassis the reading must be infinite.

An other abnormality exists that must be corrected before the receiver is returned to the customer.

#### Leakage Current Hot Check (See below Figure)

Plug the AC cord directly into the AC outlet.

**Do not use a line Isolation Transformer during this check.**

Connect 1.5K/10watt resistor in parallel with a 0.15uF capacitor between a known good earth ground (Water Pipe, Conduit, etc.) and the exposed metallic parts.

Measure the AC voltage across the resistor using AC voltmeter with 1000 ohms/volt or more sensitivity.

Reverse plug the AC cord into the AC outlet and repeat AC voltage measurements for each exposed metallic part. Any voltage measured must not exceed 0.75 volt RMS which corresponds to 0.5mA.

In case any measurement is out of the limits specified, there is possibility of shock hazard and the set must be checked and repaired before it is returned to the customer.

#### Leakage Current Hot Check circuit

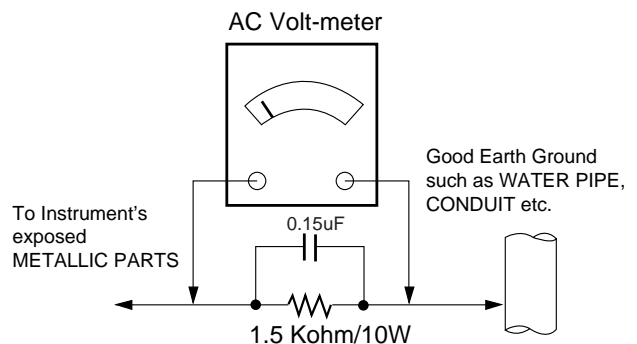

# SPECIFICATIONS

Note : Specification and others are subject to change without notice for improvement.

## Scope

This specification is applied to all the television related to CW - 81B Chassis.

5) The receiver must be operated for about 20 minutes prior to the adjustment.

## Requirement for Test

Each part is tested as below without special appointment.

- 1) Temperature :  $25 \pm 5^{\circ}\text{C}$  ( $77 \pm 9^{\circ}\text{F}$ ), CST :  $40 \pm 5$
- 2) Relative Humidity :  $65 \pm 10\%$
- 3) Power Voltage : Standard input Voltage AC220V ~ 50/60Hz.  
\* Standard Voltage of each products is marked by models.
- 4) Specification and performance of each parts are followed each drawing and specification by part number in accordance with BOM.

## Test Method

- 1) Performance : LGE TV test method followed.
- 2) Demanded other specification

Model	Market	Remark	Appliance
T4/Z4 Model	PAL Model	Safety: CB Spec. (EN60065) EMC: CE Spec (EN55020, EN55013)	

## General specification

No.	Item	Specification	Remark
1	Receiving System	PAL BG, DK, I / NTSC M (AV 3.58/ 4.43)	China/ Indonesia/ Thai/ Vietnam
		PAL BG, DK, I / NTSC M (AV 3.58/ 4.43) SECAM DK	CIS
		PAL NM / NTSC M (AV 3.58)	L America/ Philippines/ Taiwan
		PAL BG, DK, I / NTSC M (AV 3.58/ 4.43) SECAM BG, DK, L	Asia/Middle East/ Africa
2	Available Channel	VHF : E2 ~ E12 UHF : E21 ~ E69 CATV : S1 ~ S20 HYPER : S21 ~ S41	PAL Model
3	Input Voltage	AC220V ~ 50/60Hz AC100 ~ 240V, 50/60Hz	East Asia Others
4	Market	Korea, Latin America, China, Indonesia, Philipines, Taiwan, Thai, Vietnam, Asia, Africa	
5	Screen Size	14 ~ 21 inch (FLAT / Conventional) 21" Superslim/Ultrastlim	
6	Aspect Ratio	4 : 3	
7	Display Method	CRT	
8	Tuning System	FVS	PAL Model
9	Operating Environment	1) Temp : 0 ~ 40 deg 2) Humidity : ~ 85 %	
10	Storage Environment	1) Temp : -20 ~ 60 deg 2) Humidity : ~ 90 %	

**Features and Function (For China, Indonesia, Vietnam, Thai, CIS / Middle East Asia, Africa)**

No.	Item		Specification		Remark
1	Feature	AV Input	2	AV 1	Rear1,(CVBS,L,R)
		AV Output	1	Monitor out	Rear
		Component	1	Input (For component)	Rear (Y,Pb,Pr,DVD-L/R)
2	Key	Local Key	Power, Vol(◀, ▶), PR(▼, ▲), MENU, OK Turbo-Picture, Sound		7EA/ Front Option
		Remocon	LG Code (NEC)		
3	Channel	Auto prog.	System/ Storage/ Normal/ Turbo		
		Manual	Storage/ System/ Channel/ Fine/ Search/ Name		
		Prog. edit	Copy/ Move/ Delete/ Skip		
		Favorite	8 Channel		
4	Picture	PSM	Dynamic/ Standard/ Mild/ Game/ User		
		User Control	Contrast/ Brightness/ Color Sharpness Tint (NTSC-M Only)		Tint: NTSC System only
		XD	ON/OFF		option
5	Sound	SSM	Flat/ Music/ Movie/ Sports/ User		AV, RF Stereo Option
		Treble/ Bass	0 ~ 100		AV, RF Stereo
		Turbo SND	ON/ OFF		Option
6	Timer	Clock	-- : --		
		Off time	-- : -- Off(On)		
		On time	-- : -- Pr 1 VOL 30 Off (On)		
		Auto off	On/ Off		
7	Special	Language	English/ Indonesia/ Thai/ Vietnam		East Asia
		Input	TV/ AV/ Component		
		Child lock	On/ Off		
	Etc.	Sleep			
8		Review			

# ADJUSTMENT

## 1. Scope of Application

These instructions are applied to CW81B Chassis.

## 2. Notes

- 1) Because this is a cold chassis, it is not necessary to use an isolation transformer. However, operating it using a transformer between the power supply line and chassis input to prevent electric shock and to protect the test instrument.
- 2) All adjustment must be done in the correct sequence. However, for better productivity, it can be change in a pre-permitted range.
- 3) Environment conditions : If not specified, it must be done in following conditions.  
Temperature :  $25 \pm 5^{\circ}\text{C}$   
Humidity:  $65\% \pm 10\%$
- 4) Power supply of SET for PAL/SECAM  
China/Indonesia/Vietnam/CIS Market: AC100~240V $\pm 10\%$ , 50/60Hz.
- 5) If not specified, the receiver must be operated for more than 20 minutes prior to the adjustment.
- 6) Signal : Received the standard color signal (65dB $\pm 1$ dBuV).  
PAL/SECAM: LG standard signal means the digital pattern PAL-B/G 05CH.
- 7) If not specified, APC ON is APC CLEAR (DYNAMIC)

## 3. AGC Voltage Adjustment

### 3-1. Necessary Instrument

- Digital Multi-meter: 1 set
- Max Input Current : Over 1A/ Max Input Voltage : 500Vdc
- Measurement Range : 10mV-100mVdc/ Accuracy : 0.03%

### 3-2. Adjustment Preparation

- 1) Input in the 75 $\Omega$  cable 65dB( $\pm 1$ dB) LG standard signal.
- 2) Connect the multi-meter to J105 (AGC Check, Marking).

### 3-3. Adjustment

- 1) Press the "INSTART" key of factory remote control and select "VP0 (RF AGC)" adjustment mode.
- 2) Press the VOL+/- (◀/ ▶) key until the multi-meter shows reading as shown below.
- 3) CAUTION: Since the signal strength can be easily changed by the condition of signal cable, you need to check the signal strength frequently in order to prevent error.

Tuner P/N	Maker	AGC Vol	Signal	Tuner Spec.	Remark
6700NFNS11E	LGIT	$2.15 \pm 0.05\text{V}$	65dBu	TAEA-H111F	Korea
6700VS0002F	LGIT	$3.0 \pm 0.05\text{V}$	65dBu	TAEW-G002D	PAL
6700PF0006B	SANYO	$2.3 \pm 0.05\text{V}$	65dBu	115-B-A86EL	PAL
6870NB0026A	LGIT	$2.15 \pm 0.05\text{V}$	65dBu	TAEA-J001F	HITACHI
6700MF0014A	LGIT	$2.3 \pm 0.05\text{V}$	65dBu	TAEW-G013D	PAL
6700MF0018A	LGIT	$2.5 \pm 0.05\text{V}$	65dBu	TAEA-G011D	SECAM(CIS)
6700MF0018B	LGIT	$2.4 \pm 0.05\text{V}$	65dBu	TAEA-G001D	PAL
6700MF0018D	LGIT	$2.4 \pm 0.05\text{V}$	65dBu	TAEA-G011D	PAL
6700MF0018E	LGIT	$2.5 \pm 0.05\text{V}$	65dBu	TAEA-G111D	SECAM(CIS)

## 4. Screen Voltage Adjustment

### 4-1. Adjustment (Using Factory Remote Control)

- 1) Input in the 75 $\Omega$  cable LG standard signal (Digital Pattern, 480NC).
- 2) Press the "ADJ" key of factory remote control once to make the TV set display horizontal line.
- 3) Turn the screen volume on the FBT clockwise until the horizontal line is visible and turn it counterclockwise until horizontal line faintly visible.  
(Exit screen voltage adjustment by press "Enter(■)" key of factory remote control.)

## 5. Purity and Convergence Adjustment

### 5-1. Purity adjustment

#### (1) Adjustment Preparation

- 1) Receive Red Raster Pattern for purity adjustment (51CH).
- 2) Demagnetize the CPT and Cabinet with a degaussing coil.

#### (2) Adjustment

- 1) Pre-adjust the static convergence (STC) with the 4 and 6pole magnet.
- 2) If the horizontal Line is inline with CPT Mark, 2-Pole magnet should direct 3-9 o'clock direction.
- 3) If not, direct 2-pole magnet handle toward 6-12 o'clock direction and adjust the Horizontal Line to fall onto the mark opening the magnet at an angle.
- 4) Push the DY(deflection yoke) all the way to the CPT funnel.
- 5) Turn the purity magnet(2-pole magnet) so that the "green" color portion of left side and the "blue" color portion on the right side have equal amount of color.

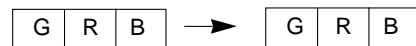

- 6) Pull the DY slowly backward and fix it when the whole screen becomes red.  
(The specified torque for fixing DY screw should be 10Kg/cm.)

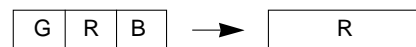

### 5-2. Convergence Adjustment

#### (1) Necessary Instrument

- 1) Degaussing Coil
- 2) Convergence fixing instrument (Speical tools)

#### (2) Adjustment Preparation

- 1) Operate the unit at least 15 minutes before adjustment.
- 2) Using degaussing coil, remove the stains on CPT & Cabinet.
- 3) Received the Cross Hatch Pattern of Convergence. (09ch)
- 4) Let the Contrast in normal luminance level.

#### (3) Static Convergence (STC) Adjustment

- 1) Receive the Cross Hatch Pattern Convergence (09ch).

- 2) Before adjusting Static Convergence (STC), adjust the focus first seeing to it that the WHITE color picture quality is sharp enough.
- 3) Converge the RED vertical and BLUE vertical line in unity (same line) by changing the angle between the 2 tabs of 4-pole magnet.
- 4) Converge the RED horizontal and BLUE horizontal line in unity (same line) by turning the 2 tabs of the 4-pole magnet. At this time, do not change the angle between the 2 tabs.
- 5) Converge the R, G, B vertical line in unity (same line) by changing the angle between the 2 tabs of the 6-pole magnet.
- 6) Converge the R, G, B horizontal line in unity (same line) by turning the 2 tabs of the 6-pole magnet. At this time, do not change the angle between the 2 tabs.

#### (4) Dynamic Convergence (DYC) Adjustment

- 1) Y-axis Adjustment:  
Adjust convergence of Y-axis (vertical) by moving the deflection yoke (DY) left and right.
- 2) X-axis Adjustment:  
Adjust convergence of X-axis (horizontal) by moving the deflection yoke (DY) up and down.

## 6. White Balance Adjustment

### 6-1. Necessary Instrument

- 1) Automatic White Balance Meter (Low/High light Pattern generator)
- 2) CRTColor Analyzer, CA -100: 1 set
- 3) Factory Remote Control

### 6-2. Adjustment Preparation

Prior to this adjustment, the Screen Voltage adjustment should be finished.

### 6-3. Automatic adjustment

- 1) Adjust using Auto White Balance Meter.
- 2) Enter CPU OFF Mode by pressing "IN-START" & "MUTE" key of factor remote control in turn before adjustment.  
Exit CPU OFF mode by press the "MUTE" key of factory remote control after adjustment finished.

\* In case there is excess RED color at screen voltage adjustment, adjust it using "volume - (◀) key of factory remote control until the RED color disappear.

### 6-4. Manual adjustment

- 1) Adjust using white Balance meter and factory remote control.
- 2) Enter white balance adjustment mode by pressing "INSTART" key of factory remote control.
- 3) Use the CH▲, CH▼ Key to choose adjustment item.
- 4) Use the VOL◀, VOL▶ Key to change item data.
- 5) Adjustment Procedure
  - a. Make the picture luminance 45Ft-L by changing the "CONTRAST" and "BRIGHTNESS".
  - b. Adjust X data of High light with R-DRIVE and Y data of high light with B-DRIVE to have the color temperature as shown below.
  - c. Make the picture luminance 4.5Ft-L by changing the "CONTRAST" and "BRIGHTNESS".
  - d. Adjust X data of low light with R-BIAS and Y data of low

light with B-BIAS to have the color temperature as shown below.

- e. Repeat steps a~d until both low and high light have the same readings as shown below.

Market	Color Temperature	X-AXIS	Y-AXIS
ALL	13,000	268±5	273±5

## 7. Focus Voltage Adjustment

This adjustment must be done after operating the TV set receiver sufficiently.

### 7-1. Adjustment Preparation

Receive the LG standard pattern (PAL: Digital pattern, 480NC,13CH) and set the picture condition on "APC ON" (CLEAR) mode.

### 7-2. Adjustment

Turn the focus volume on the FBT upper direction to have the best focus vertical line (Fig. 1(a)) and horizontal line (Fig. 1(b)) as shown below.

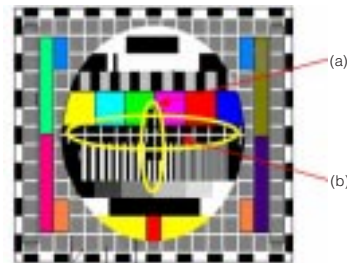

<Fig. 1>

## 8. SUB-BRIGHTNESS Adjustment

8-1. Sub brightness adjustment is unnecessary (Don't adjust).

### 8-2. Sub-Tint adjustment

This adjustment has to be done only if the picture has bad tint otherwise, it can be omitted if the picture has good tint.

- 1) Receive LG standard pattern signal (SMPTE, 2CH)
- 2) Set the picture condition on "APC ON" (CLEAR) mode.
- 3) Press the "ADJ" key of the factory remote control three times to enter to "SUB-TINT" adjustment mode.
- 4) Change the Sub-Tint data by pressing the VOL◀, VOL▶ key until the upper and lower CYAN color becomes same color.

## 9. Deflection setting data adjustment

These adjustment will be done by automatic adjustment Equipment.

For manual adjustment, it is also possible by the following procedure.

### 9-1. Adjustment Preparation

- 1) Deflection setting data adjustment can be done only with remote control.
- 2) Press "IN-START" key on factory remote control continuously to enter to Deflection Adjustment mode.
- 3) Press the CH▲, ▼ key to select adjustment item.

- 4) Press the VOL◀, ▶ key to change the data.

## 9-2. Adjustment

- 1) Horizontal Position Adjustment  
Select SVC02(H-POS) and adjust so that the left and right vertical line are symmetrical as possible.
- 2) Vertical Position Adjustment  
Select SVC02(V-POS) and adjust so that the horizontal center line coincide with geometric horizontal center of the CPT.
- 3) Vertical Size Adjustment  
Select SVC02(VA) and adjust so that the middle circle of the Digital Pattern(480NC, 13CH) coincide with the effective screen of CPT.

## 9-3. Adjustment (21" Superslim, Ultra S/S Model)

- 1) Vertical Position Adjustment  
Select SVC02(V-POS) and adjust so that the horizontal center line coincide with geometric horizontal center of the CPT.
- 2) Vertical linearity Adjustment  
Select SVC02(V-LIN) and adjust so that the size of the upper circle is alike with the one of the lower circle at LG standard pattern (PAL: EU05CH, NTSC: 13CH)
- 3) Vertical Size Adjustment  
Select SVC02(VA) and adjust so that the middle circle of the Digital Pattern(PAL B/G 5CH) has 6~7mm gaps from the effective screen of CPT
- 4) Horizontal Position Adjustment  
Select SVC02(H-POS) and adjust so that the left and right vertical line are symmetrical as possible.
- 5) Horizontal Size Adjustment  
Select SVC02(EW WIDTH) and adjust so that the outer line of the left and right and the remotest grid will correspond to the effective boundary surface. (The remotest grid PAL: within 0~25%; NTSC: within 2.5~3.0 column)
- 6) Parabola Adjustment  
Select SVC02(EW PARAB) and adjust so that the vertical line of the remotest grid at the left or right side of the screen will be parallel to the vertical line of the center of screen. (or the remotest grid of CPT)
- 7) Trapezoidal Adjustment  
Select SVC02(EW TRAPE) and adjust so that the width of the upper part of screen is alike with the one of the lower part of the screen.
- 8) EW UPCOR / LOCOR Adjustment  
Select SVC02(EW C UPCOR, EW LOCOR) and adjust so that the vertical line in the four corners become straight line.
- 9) BOW Adjustment  
Select SVC02(HP BOW) and adjust so that the vertical line in the four corners become straight line.

## 10. IIC BUS SUB Adjustment Data Table

OSD	Range	PAL	NTSC	Secam
SUB-BRIGHTNESS	0 ~ 100	40	40	40
SUB-TINT	-20 (R) ~ +20 (G)	R5	R1	R5

## 11. Auto Adjustment Preparation Setting Table

	VIDEO IC	EEPROM	Speed	Delay
SLave ADD	BA	A0	1	5

VCD	TV				PC			
	R DRIVE	R BIAS	B DRIVE	B BIAS	B AMP	B CUT	G AMP	G CUT
Sub Add	D	A	F	C				
Start Bit	6	7	6	7				
Stop Bit	0	0	0	0				
Masking	0	0	0	0				
Direction	1	1	1	1				

EEPROM	8D	8A	8F	8C
Sub Add				

SpeedPlus	3	3	3	3
Step/Data				



## 12. EEPROM OPTION TABLE ( <Table 1> PAL MODEL SOUTH EAST, <Table 2> PAL MODEL MIDDLE EAST)

You can find the EEPROM Option Data if entering the IN-START key of the adjustable remote control and then pressing the MENU key.

OPTION 1	CODE	DESCRIPTION	REMARK
CPT	0/1	0: Slim/Ultra, 1:Conv/Flat	
TURBO SND	0/1	1: With; 0: Without	
V-CURVE	0/1	1: Volume Curve high; 0: Volume Curve low	
V-MUTE	0/1	1: With Video Mute; 0: Without	
SND MUTE	0/1	1: With Sound Mute(no signal);0: Without(no signal)	
OPTION 2	CODE	DESCRIPTION	REMARK
DVD	0/1	1: With DVD input; 0: Without	
EYE	0/1	1: With; 0: Without	
GAME	0/1	1: With Game Module ; 0: Without	
X-WAVE	0/1	1: With X-WAVE; 0: Without X-WAVE	
COLOR T	0/1	1: Color+10 STEP; 0: -	
Degauss	0/1	1: With; 0: Without	
HOTEL	0/1	1: With; 0: Without	
200Pr	0/1	1: 200 Program; 0: 100 Program	
OPTION 3	CODE	DESCRIPTION	REMARK
QUARRAN	0/1	1: With QUARRAN; 0: Without QUARRAN	
DUAL SV	0/1	1: With DUAL SAVING; 0: Without	
PIP	0/1	1: SYNC KILL=1(no signal); 0: SYNC KILL=0 (no signal)	
SND FL1	0/1	1: 10:75KHZ (mono filter); 0: 00:50KHZ (mono filter)	
SND FL2	0/1	1: 11:200KHZ(mono filter); 0: 01:100KHZ (mono filter)	
SND2 FL1	0/1	1: 10:27BKHZ(ch2 FIR FILTER); 0:00:27AKHZ(ch2 FIR FILTER)	
SND2FL2	0/1	1: 11:AMKHZ(ch2 FIR FILTER); 0: 01:50KHZ(ch2 FIR FILTER)	
HIDEV	0/1	1: FM High-Deviation Demodulation; 0: FM Normal Demodulation	
OPTION 4	CODE	DESCRIPTION	REMARK
OSD LANG	0	0: INDONE (IND/ENG)	INDONESIA
	1	1: THAI (THA/ENG)	THAILAND
	2	2: VIETNA (VIE/ENG)	VIETNAM
	3	3: MULTI: ENG/IND/THA/VIE	
Pakistan Bass	0/1	0: Normal Bass operation; 1: Decreased Bass operation for Pakistan	
	4	4: AUS: ENG	
OPTION 4	CODE	DESCRIPTION	REMARK
SND MODE	0/1/2/3	0: MONO;1: AV STEREO;2:RF STEREO; 3:AV ST NOSW	
	AV	0: NO AV; 1: AV1; 2: AV1 2	
Local KEY	0/1/2	0: 4 KEY; 1: 6 KEY; 2: 8 KEY	
Nicam on Th	0/1	0:NICAM ON TH Off; 1:NICAM ON TH On	

<Table 1>

OPTION 1	CODE	DESCRIPTION	REMARK
CPT	0/1	1: Slim/Ultra, 0:Conv/Flat	
V-CURVE	0/1	1: Volume Curve high; 0: Volume Curve low	
V-MUTE	0/1	1: With Video Mute; 0: Without	
SND MUTE	0/1	1: With Sound Mute(no signal);0: Without(no signal)	
Teletext	0/1	1: With; 0: Without	
Reserved			
OPTION 2	CODE	DESCRIPTION	REMARK
DVD	0/1	1: With DVD input; 0: Without	
EYE	0/1	1: With; 0: Without	
GAME	0/1	1: With Game Module ; 0: Without	
X-WAVE	0/1	1: With Blue Back; 0: Without X-WAVE	
COLOR T	0/1	1: Color+10 STEP; 0: -	
Degauss	0/1	1: With; 0: Without	
HOTEL	0/1	1: With; 0: Without	
200Pr	0/1	1: 200 Program; 0: 100 Program	
OPTION 3	CODE	DESCRIPTION	REMARK
QUARRAN	0/1	1: With QUARRAN; 0: Without QUARRAN	
DUAL SV	0/1	1: With DUAL SAVING; 0: Without DUAL SAVING	
PIP	0/1	1: SYNC KILL=1(no signal); 0: SYNC KILL=0 (no signal)	
SND FL1	0/1	1: 10:75KHZ (mono filter); 0: 00:50KHZ (mono filter)	
SND FL2	0/1	1: 11:200KHZ(mono filter); 0: 01:100KHZ (mono filter)	
SND2FL1	0/1	1: 10:27BKHZ(ch2 FIR FILTER); 0:00:27AKHZ(ch2 FIR FILTER)	
SND2 FL2	0/1	1: 11:AMKHZ(ch2 FIR FILTER); 0: 01:50KHZ(ch2 FIR FILTER)	
HIDEV	0/1	1: FM High-Deviation Demodulation; 0: FM Normal Demodulation	
OPTION 4	CODE	DESCRIPTION	REMARK
OSD LANG	0	0: ENG (ENG)	
	1	1: ARAB (ENG/FRE/ARAB/URUD)	
	2	2: FARSI (ENG/FARSI)	
TXT LANG	0/1/2/3	0: EU WEST; 1: EU EAST; 2: ARABIC 3: FARSI	
	4/5/6/7	4:RUSSIAN W; 5:RUSSIAN E; 6:UKRAINIAN	
	/8	7:BYELORUSS; 8:GREEK	
Pakistan Bass	0/1	0: Normal Bass operation; 1: Decreased Bass operation for Pakistan	
	OPTION 5	CODE	DESCRIPTION
Snd Mode	0/1/2/3	0: MONO; 1: AV STEREO; 2: RF STEREO; 3:AV ST NOSW	
	AV	0: NO AV; 1: AV1; 2: AV1 2	
Local Key	0/1/2	0: 4 KEY; 1: 6 KEY; 2: 8 KEY	
Nicam on Th	0/1	0:NICAM ON TH Off; 1:NICAM ON TH On	
NICAM off	0/1	0:NICAM ON TH Off; 1:NICAM ON TH On	

<Table 2>

<TABLE 3 >

SVC	Register	Range	Initial(PAL)	Initial(SECAM)	Remark
SVC 01	RF AGC	0 ~ 63	38	38	Necessary
	R BIAS	0 ~ 255	90	90	Necessary
	G BIAS	0 ~ 255	90	90	Others CPT
			127	127	IRICO CPT
					Unnecessary
	B BIAS	0 ~ 255	90	90	Necessary
	R DRIVE	0 ~ 127	90	90	Necessary
	G DRIVE	0 ~ 127	85	85	Unnecessary
	B DRIVE	0 ~ 127	90	90	Necessary
Y-DELAY	0 ~ 15	7	7	Unnecessary	
OSD CONT.	0 ~ 7	5	5	Unnecessary	
OSD POS.	0 ~ 60	42	40	Unnecessary	
SVC 02	V POS	0 ~ 15	6	8	Ultra 2 LG CPT
			7		Ultra HF CPT
			7		FLAT HF CPT
					FLAT RICO CPT
			9		FLAT LG CPT
					Necessary
	V LIN	0 ~ 31	19	18	Ultra 2 LG CPT
			18	17	Ultra HF CPT
			20		FLAT HF CPT
				17	FLAT RICO CPT
			19	18	FLAT LG CPT
					Unnecessary
	VA	0 ~ 127	37	37	Ultra 2 LG CPT
			54		Ultra HF CPT
			12		FLAT HF CPT
					FLAT RICO CPT
			22		FLAT LG CPT
					Necessary
	H POS	0 ~ 31	16	20	Ultra 2 LG CPT
			18		Ultra HF CPT
			14		FLAT HF CPT
					FLAT RICO CPT
			16		FLAT LG CPT
					Necessary
	EW WIDTH	0 ~ 127	65	65	Ultra 2 LG CPT
			95		Ultra HF CPT
					FLAT HF CPT
					FLAT RICO CPT
					FLAT LG CPT
					Necessary
	EW PARAB	0 ~ 127	27	24	Ultra 2 LG CPT
			17		Ultra HF CPT
					FLAT HF CPT
					FLAT RICO CPT
					FLAT LG CPT
					Necessary
	EW TRAPE	0 ~ 127	16	14	Ultra 2 LG CPT
			15		Ultra HF CPT
					FLAT HF CPT
					FLAT RICO CPT
					FLAT LG CPT
					Necessary
EW UPCOR	0 ~ 31	14	14	Ultra 2 LG CPT	
		16		Ultra HF CPT	
				FLAT HF CPT	
				FLAT RICO CPT	
				FLAT LG CPT	
				Necessary	
EW COR	0:normal mode	0	0	Unnecessary	
	1:corner pin gain up mode				

<TABLE 3 >

SVC	Register	Range	Initial(PAL)	Initial(SECAM)	Remark
SVC 02	HP BOW	0 ~ 31	18	18	Necessary
					Ultra HF CPT
	HP ANGLE	0 ~ 31	16	16	Necessary
	HS COMP	0 ~ 7	7	7	Unnecessary
	V SC	0 ~ 7	18	18	Unnecessary
	V COMP	0 ~ 7	7	7	Unnecessary
	HS COMP	0 ~ 7	7	7	Unnecessary
	V DC	0 ~ 63	24(55)	24(55)	Unnecessary
	VBLK SW	0~3	0(1)	0(1)	Unnecessary
	H BLK L	0 ~ 7	2	2	Unnecessary
H BLK R	0 ~7	2	2	Unnecessary	
EW Cor	0: Normal mode; 1: Corner pin gain up mode		0	0	Unnecessary
SVC 03	DEEM TC	0: 50us ; 1: 75us	0	0	Unnecessary
	FM GAIN	0: 500mVrms@± 50KHz. deviation (for PAL)	0	0	Unnecessary
	A2 SW	0: Normal mode; 1: 5.74MHz mode need to set SIF system=1	0	0	Unnecessary
	SIF SYS	0: 4.5MHz; 1: 5.5MHz; 2: 6.0MHz; 3: 6.5MHz	1	1	Unnecessary
	CH CONV	0: Normal BPF mode; 1: CH converter measure mode at India	0	0	Unnecessary
	FM MUTE	0: Enable FM output; 1: Disable FM output	0	0	Unnecessary
	VOL FIL	0: Filter OFF; 1: TV operating mode	1	1	Unnecessary
	VOLUME L	0 ~ 127	18	38	Unnecessary
	AUDIO SW	MONO Mode: 0 (0: Stereo EXT; 1: Stereo INT) MONO Mode: 1 (0: MONO CH1; 1: MONO CH2; 0: MONO CH3; 1: MONO CH4)	0	0	Unnecessary
	SURR CNT	0: Surround OFF; 1: MODE-A (-3dB); 2: MODE-B (0dB); 3:MODE-C(+3dB)	0	0	Unnecessary
	MONO	0: STEREO input mode; 1: MODE input mode	0	0	Unnecessary
	VOLUME R	0 ~ 127	18	38	Unnecessary
	TONE ATT	0: 0dB; 1: -6dB	0	0	Unnecessary
	T BOOST C	0: Cut; 1: Boost	0	0	Unnecessary
	TREBLE	0 ~ 63	23	23	Unnecessary
	PSEUDO ST	0: Pseudo Stereo OFF; 1: Pseudo Stereo ON	0	0	Unnecessary
	BBOOST C	0: Cut; 1: Boost	1	1	Unnecessary
	BASS GA	0 ~ 63	20	20	Unnecessary
	S TRAP	0 (min) ~ 7 (max)	7	7	Unnecessary
	S TRAP SW	0: Sound trap OFF mode (need external trap); 1: Normal mode (sound trap ON)	1	1	Unnecessary
SVC 04	F DDS	0: Normal mode (NTSC: work; PAL/SECAM: stop); 1: Forced DDS mode (always work)	0	0	Unnecessary
	DELAY T	Delay Test	1	1	Unnecessary
	Y FILTER	0: 3.58MHz Trap; 1: 4.43MHz Trap; 2: Wide mode; 3: 4.286MHz Trap	1	1	Unnecessary
	C FILTER	0: 3.58MHz peaking; 1: 3.58MHz symmetrical; 2: 4.43MHz peaking; 3: 4.43MHz symmetrical	0	0	Unnecessary
	Y APF	0: Chroma trap ON (composite video mode) 1: Chroma trap OFF (YCbCr mode and YC mode)	0	0	Unnecessary
	COR GAIN	0: Coring OFF; 1: Coring Gain 1(minimum); 2: Coring Gain 2(middle); 3: Coring Gain 3(maximum)	2	2	Unnecessary
	P SHOOT	0 (narrow) ~ 3 (wide)	0	0	Unnecessary
	O SHOOT	0 (narrow) ~ 3 (wide)	0	0	Unnecessary
	WPL OPE	0: WPL OFF; 1: High operating point; 2:Middle operating point; 3: Low operating point	0	0	Unnecessary
	GAMMA ST	0: Low operating point; 1: Middle operating point; 2: High operating point; 3: Defect	3	3	Unnecessary
	DC REST	0: 100%; 1: 107%; 2: 113%; 3: 129%	0	0	Unnecessary
	BS START	0: Black Stretch ON (Starting Point=401RE); 1: Black Stretch ON (Starting Point=501RE) 2: Black Stretch ON (Starting Point=601RE) 3: Black Stretch OFF	3	3	Unnecessary
	BS GAIN	0 (min) ~ 2 (max)	3	3	Unnecessary
	C TRAP	0 (min) ~ 7 (max)	2	2	Unnecessary
	C BPF	0 (min) ~ 3 (max)	1	1	Unnecessary
	GAMMA GA	0 (min) ~ 3 (max)	0	0	Unnecessary
	GRAY MDE	0: White (70%); 1: Gray (15%)	0	0	Unnecessary
	YCMIX	0: YC_C; 1: 2.2V_DC	0	0	Unnecessary
	TXT CC	0: Output without LPF; 1: Output by LPF	W/O TXT:0 W/ TXT:1	W/O TXT:0 W/ TXT:1	Unnecessary
	VIN/XRGB	0: FBP/EXT RGB IN; 1: YC-C/DVD-Y/CR-IN/CB-IN	1	1	Unnecessary

SVC	Register	Range	Initial(PAL)	Initial(SECAM)	Remark
SVC 05	T DISABLE	0: Test mode; 1: TV operating normally	1	1	Unnecessary
	H FREQ	0 ~ 63	70	70	Unnecessary
	AFC G	0: Automatic mode; 1: Enforce high gain mode	0	0	Unnecessary
	A MUTE	0: Audio Mute OFF; 1: Audio Mute ON	1	1	Unnecessary
	V MUTE	0: Video Mute OFF; 1: Video Mute ON	0	0	Unnecessary
	SYN KILL	0 ~ 1	0	0	Unnecessary
	V KILL	0: TV operating mode; 1: Defeat the vertical output	0	0	Unnecessary
	VSEP	0: Normal mode; 1: Sensitivity up mode	0	0	Unnecessary
	V RES T	0: Normal mode; 1: Sensitivity up mode	0	0	Unnecessary
	HLVDET	0: If H-Lock is not defect, stop vertical sync detection 1: V sync system always working	1	1	Unnecessary
	V SYN		0	0	Unnecessary
	CD MODE	0 ~ 7	0	0	Unnecessary
	FBPBLK	0 ~ 1	1	1	Unnecessary
	AFC NST	0: Normal mode; 1: Enforce low gain mode (non-standard)	0	0	Unnecessary
	AFC2SW	0: About 4us ~ 8us; 1: about 8us ~ 12us	0	0	Unnecessary
	CROSS BW	0: TV operating mode; 1: Black pattern; 2: White pattern; 3: Crosshatch pattern	0	0	Unnecessary
	BLK DEF.	0: Blanking ON (normal mode); 1: Blanking OFF	0	0	Unnecessary
SUB BIAS	0 ~ 127	35	35	Unnecessary	
V TRANS	0: Random transmission; 1: Transmission between vertical retrace period	1	1	Unnecessary	
DIG OSD	0: Analogue OSD mode; 1: Digital OSD mode	0	0	Unnecessary	
SVC 06	RGB CONT	0 ~ 15	8	8	Unnecessary
	RGB TEMP	0: -1VBE; 1: Flat	0	0	Unnecessary
	ACL DEF.	0: ACL Defect OFF; 1: ACL Defect ON	0	0	Unnecessary
	ACL SW	0: High sensitivity; 1: Low sensitivity	1	1	Unnecessary
	ABL DEF.	0: ABL Defect OFF; 1: ABL Defect ON	0	0	Unnecessary
	MID STP	0: Enable limit operating; 1: Disable limit operating	1	1	Unnecessary
	ABL TH	0 ~ 7	3	3	Unnecessary
	VXO ADJ		5	5	Unnecessary
	CrCb IN	0: Video; 1: CbCr	0	0	Unnecessary
	C EXT	0: Internal composite video signal; 1: From pin 2 input	0	0	Unnecessary
	C BYPASS	0: Bypass OFF; 1: Bypass ON (used in Y/C mode)	0	0	Unnecessary
	C KI ON	0: Automatic mode (TV in operation); 1: Enforce killer ON when color control is min	0	0	Unnecessary
	C KI OFF	0: TV in operation; 1: Test mode, killer circuit is not in operation	0	0	Unnecessary
	C KI OPE	0 ~ 7 (-30dB ~ -40dB)	4	4	Unnecessary
	GRN ADJ	0 ~ 7 (Auto green off ~ level high)	0	0	Unnecessary
	TINT TH	0: Normal mode; 1: Tint control set center value (can't control tint)	0	0	Unnecessary
	ID KILL	0: Easy to become NTSC; 1: Easy to become PAL	7	7	Unnecessary
CVCO ADJ	0 ~ 7	4	4	Unnecessary	
VCO CNTR	0: Normal mode; 1: VCO free run mode	2	2	Unnecessary	
FSC/STOP	0: FSC OUT; 1: EHT	1	1	Unnecessary	
SVC 07	C SYS	0: PAL/NTSC/4.43 NTSC (AUTO); 1: PAL-M/PAL-N/NTSC(AUTO) 2: PAL; 3: PAL-M; 4: PAL-N; 5: NTSC; 6: 4.43NTSC; 7: Not available	0	0	Unnecessary
	RY BY GA	0 ~ 15	8	8	Unnecessary
	RY BY AN	0 ~ 15	10	10	Unnecessary
	R-Y LEVEL	0 ~ 31	16	16	Unnecessary
	B-Y LEVEL	0 ~ 31	12	12	Unnecessary
	GY AMP	0 ~ 15	10	10	Unnecessary
	HTNo Clr	0: Color ON; 1: Color OFF	0	0	Unnecessary
	VXO Free	0: Normal mode; 1: VXO free run mode	0	0	Unnecessary
	VXO Stby	0: Normal mode; 1: VXO Standby mode	0	0	Unnecessary
	IF AGC	0: Normal mode; 1: Minimize the gain of VIF amplifier	0	0	Unnecessary
	SVO SW	0: Internal Video out mode; 1: Selected External video output mode	0	0	Unnecessary
	VIF SYS	0: 38.0 MHz; 1: 38.9MHz; 2: 39.5MHz; 3: 45.75MHz	1	1	Unnecessary
	V LEVEL	0 ~ 7	4	4	Unnecessary
	OM TYPE	0: APC Voltage sample hold circuit type; 1: APC detector stop type	0	0	Unnecessary
	OM SW	0: Normal mode; 1: Over modulation measure circuit ON	0	0	Unnecessary
	OM LEVEL	0 ~ 15	8	8	Unnecessary
	VCO FREQ	0 ~ 255	100	100	Unnecessary
AMONI SW	0: Normal mode (de-emphasis FM detector); 1: SAO mode at external audio input mode	0	0	Unnecessary	
AFT SENS	0: ±200KHz (4.5-0.5v change); 1: ±150KHz (4.5-0.5v change) 2: ±100KHz (4.5-0.5v change); 3: ±50KHz (4.5-0.5v change)	0	0	Unnecessary	
VCO ADJ		15	15	Unnecessary	

SVC	Register	Range	Initial(PAL)	Initial(SECAM)	Remark
SVC 08	VIDEO SW	0: Internal; 1: External; 2: DVD-Y; 3: YC-Y	0	0	Unnecessary
	SYNC SS	000: Low (sync tip side); 100: Middle (normal); 111: High (pedestal side)	2	2	Unnecessary
	DinterLace	0: Normal mode; 1: Deinterlace mode	0	0	Unnecessary
	OE TEST		0	0	Unnecessary
	Ext RB	Ext R Bias setting	8	8	Unnecessary
	Ext GB	Ext G Bias setting	8	8	Unnecessary
	Ext BB	Ext B Bias setting	8	8	Unnecessary
	Ext RDr	Ext R Drive setting	8	8	Unnecessary
	Ext GDr	Ext G Drive setting	8	8	Unnecessary
	Ext BDr	Ext B Drive setting	8	8	Unnecessary
	MONI C2		0	0	Unnecessary
	DDS BPF	DDS Band Pass Filter	2	2	Unnecessary
	BELL ADJ	Secam IC Only		11	Unnecessary
	BELL MONI	Secam IC Only		0	Unnecessary
	S KIL OPE	Secam IC Only		0	Unnecessary
	S KIL ON	Secam IC Only		0	Unnecessary
	S KIL OFF	Secam IC Only		0	Unnecessary
	BellBypas	Secam IC Only		0	Unnecessary
	Text Hpos	Text Only	3	3	Unnecessary
	Text VPos	Text Only	3	3	Unnecessary
SVC 09	DE EM SW		1	1	Unnecessary
	CIK STOP		0	0	Unnecessary
	TEST MODE		0	0	Unnecessary
	MONI cbcr		0	0	Unnecessary
	IF TEST		0	0	Unnecessary
	DVD VOL	0:NORMAL ~ 100:Min(Reduce DVD Volume)	0	0	Unnecessary
	MAX VOL	Only for hotel model	100	100	Unnecessary
	CLPDEL50	PIP	18	18	Unnecessary
	CLPDEL60	PIP	18	18	Unnecessary
	CLPLEN	PIP	2	2	Unnecessary
	CLMPID	PIP	1	1	Unnecessary
PIP H	PIP	2	2	Unnecessary	
SVC 10	Ch1 Pre	+24dB~0dB~-6dB	29	29	Unnecessary
	FM 2 Pre	+24dB~0dB~-6dB	29	29	Unnecessary
	NICAM Pre	+24dB~0dB~-6dB	30	30	Unnecessary
	MONO Pre	+24dB~0dB~-6dB	10	10	Unnecessary
	CH1 - M TH	0~127	48	48	Unnecessary
	CH1 - L TH	0~255	0	0	Unnecessary
	CH2 - M TH	1~127	47	47	Unnecessary
	CH2 - L TH	1~255	0	0	Unnecessary
	BERL	0~255 msec	5	5	Unnecessary
	BERH	0~255 msec	160	160	Unnecessary
	CKRVCNT1	Clock recovery count level1 (0~127)	4	4	Unnecessary
	CKRVCNT2	Clock recovery count level2 (0~127)	2	2	Unnecessary
	NICAM ON TH		5	5	Unnecessary
	BERSEL		1	1	Unnecessary
AGCEN		0	0	Unnecessary	

# TROUBLE SHOOTING

## 1. TV FUNCTIONAL

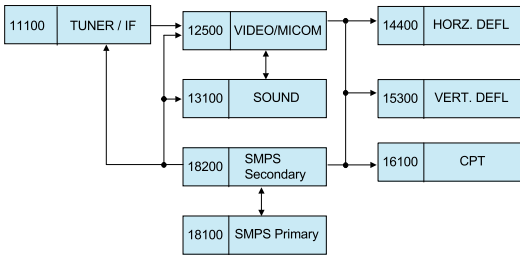

## 2. TU / IF SECTION

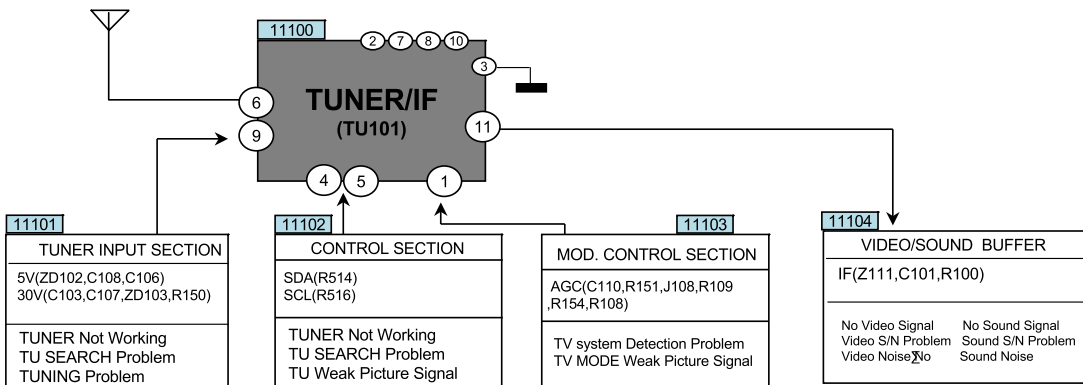
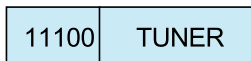

## 3. VIDEO PROCESSING

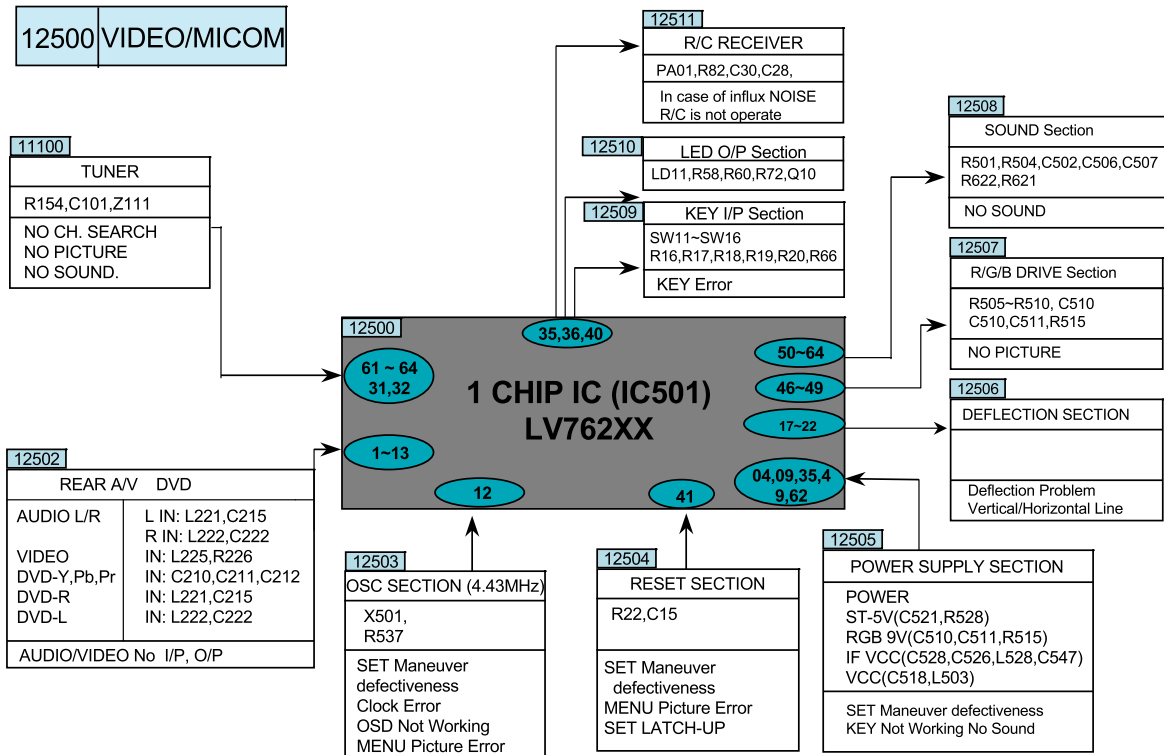

### 4. SMPS PRIMARY SECTION

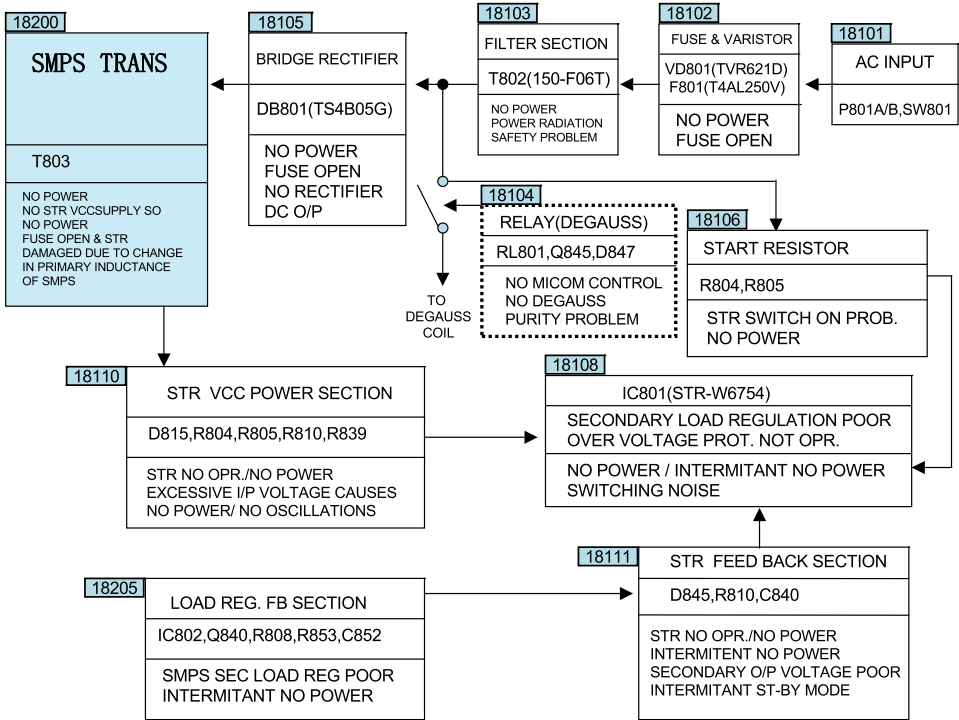

### 5. SMPS SECONDARY SECTION

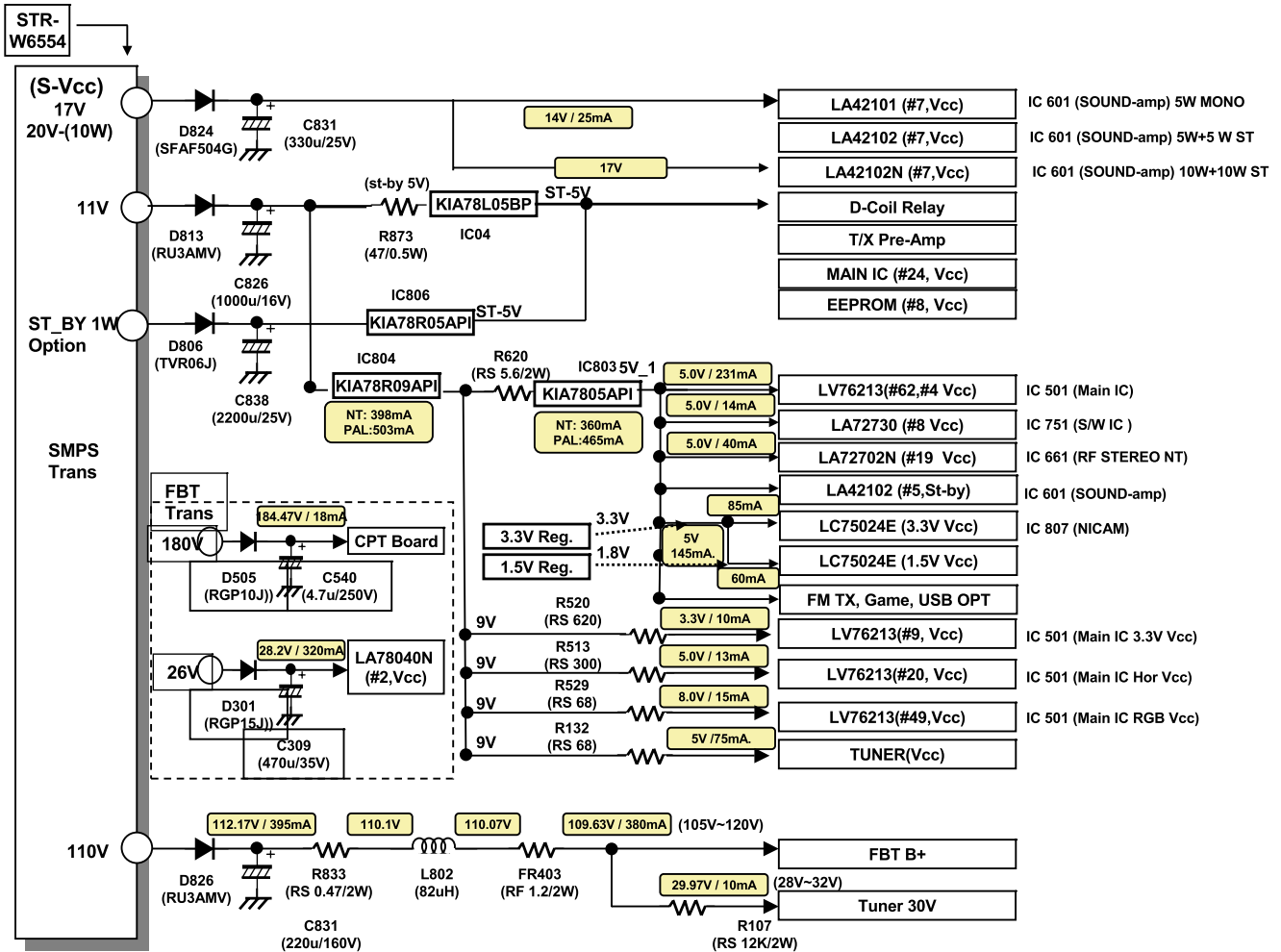

## 6. VERTICAL SECTION

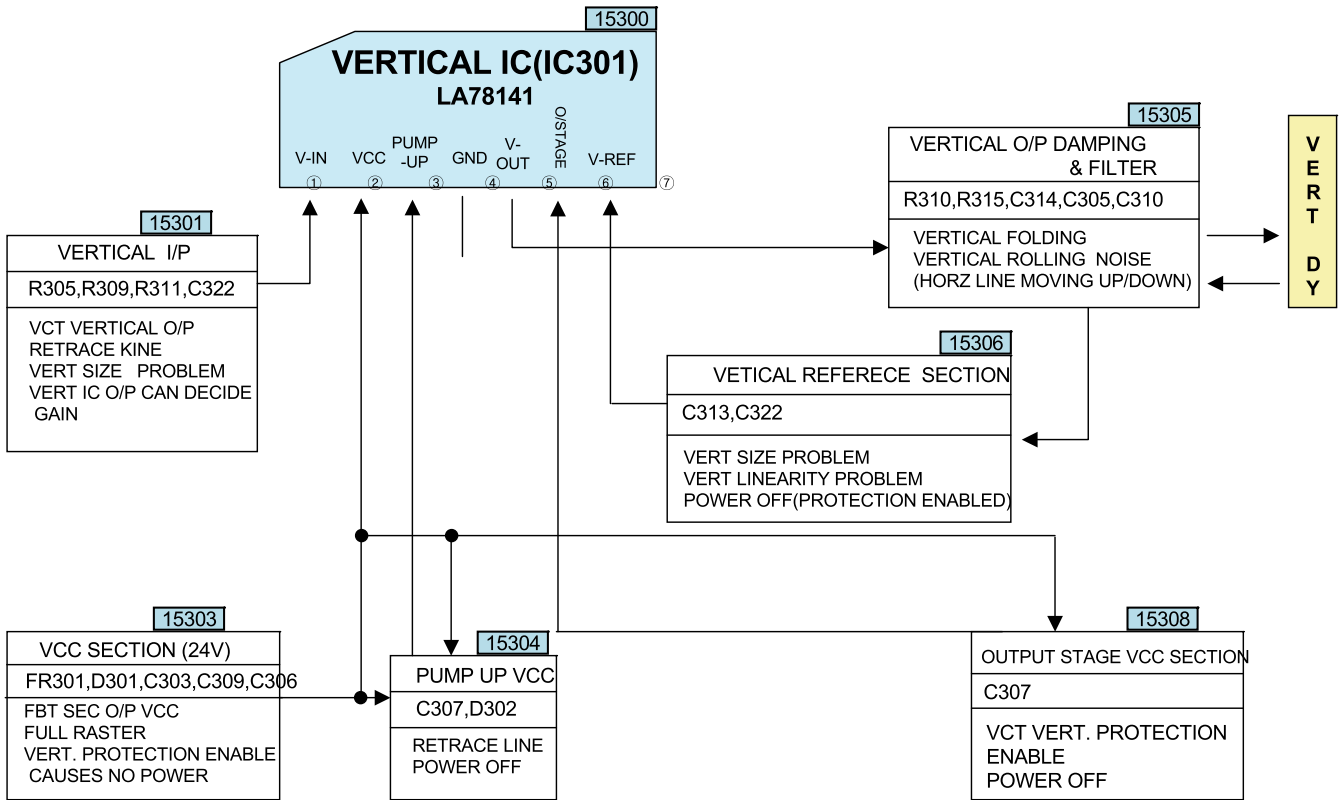

## 7. HORIZONTAL SECTION

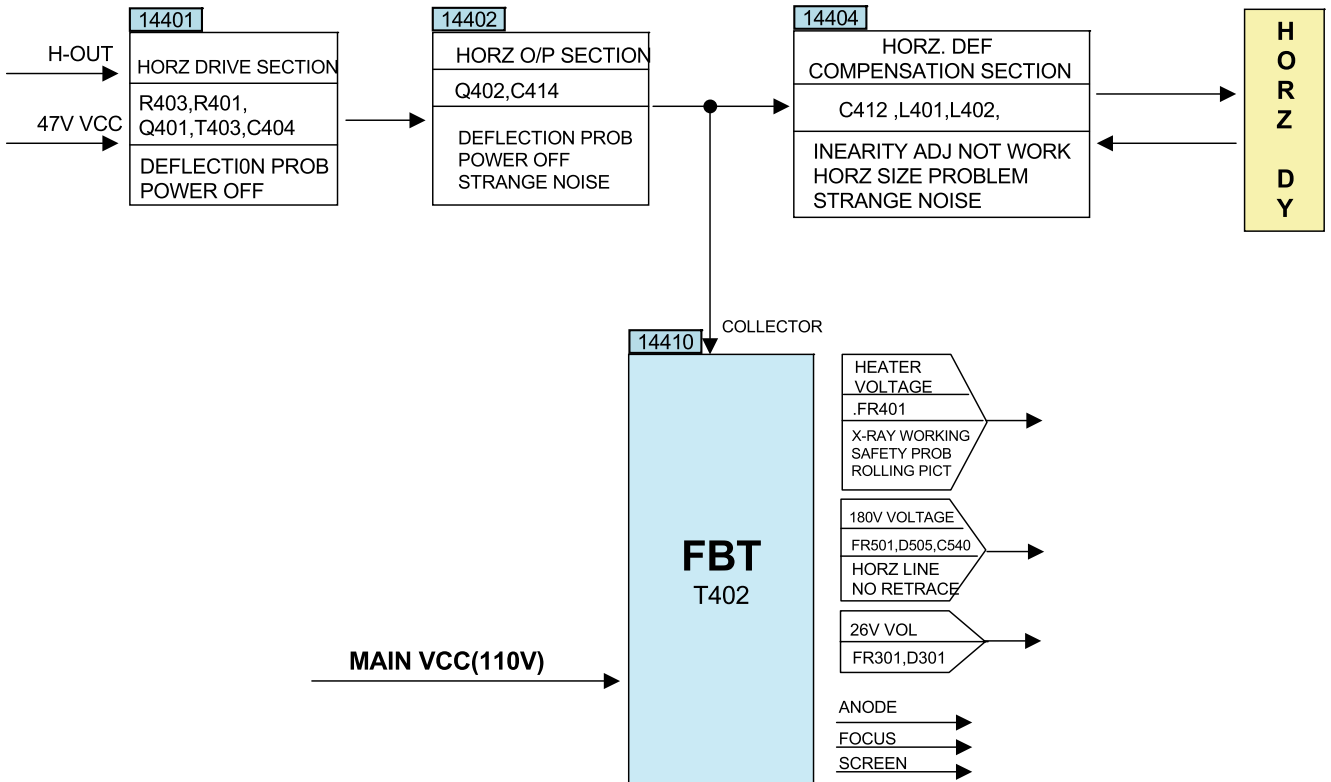



## 8. SOUND PROCESSING SECTION

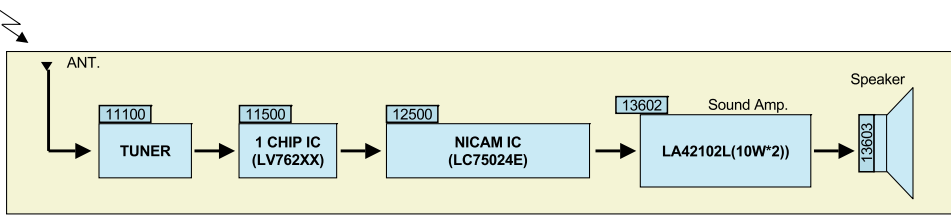

- TUNER : RF signal is feed to TUNER through Antenna. IF output from Tuner is then given to 1 CHIP IC.
- 1 CHIP IC : 1 CHIP IC processes the input IF. Demodulates Picture and sound information and gives analog R G B output for Display and SPKL/R as audio output, this sound output is further Amplified and feed to speakers.
- Sound Amp : Sound amps(LA42102L) is and Audio Amplifier it amplifies the output sound signal from Surround ic(LC75024E) and feeds to speaker which generates Sound.

## 9. CPT DRIVE SECTION

### CPT Board Circuit 16100

The CPT-BOARD assembly is composed of discrete type RGB Amplifier.  
 Amp- Gain is defined by Resistance of R917, R912,R923.  
 High Frequency compensation is made by inductance of L901, capacitance of C907,C904 and C902.  
 DC level of emitter of Q901,Q902 and Q903 is defined by R908.

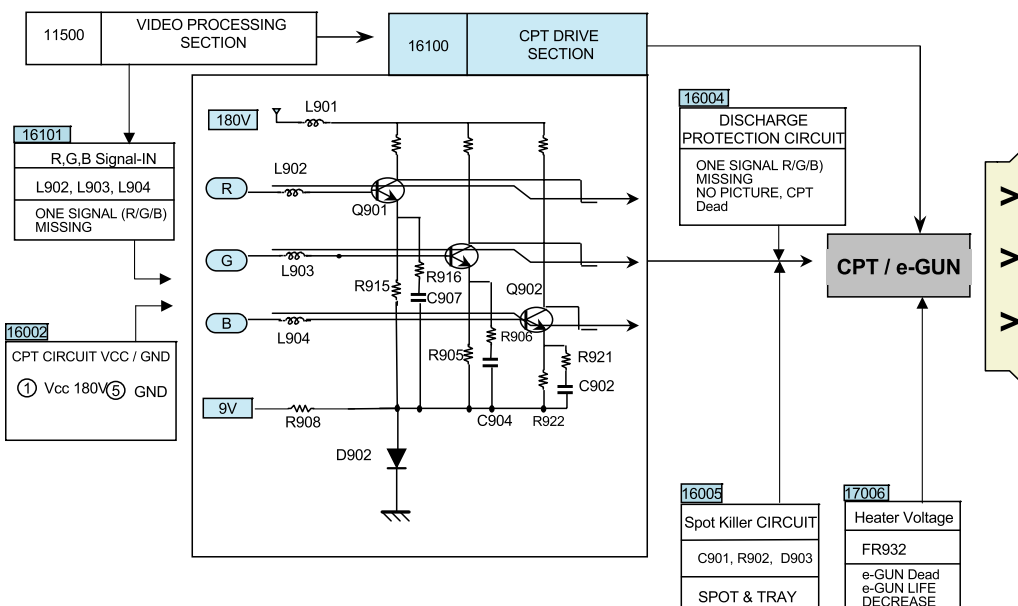
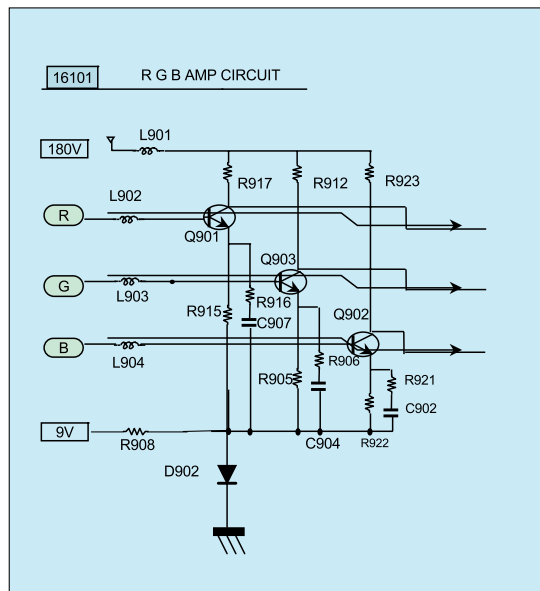

# BLOCK DIAGRAM

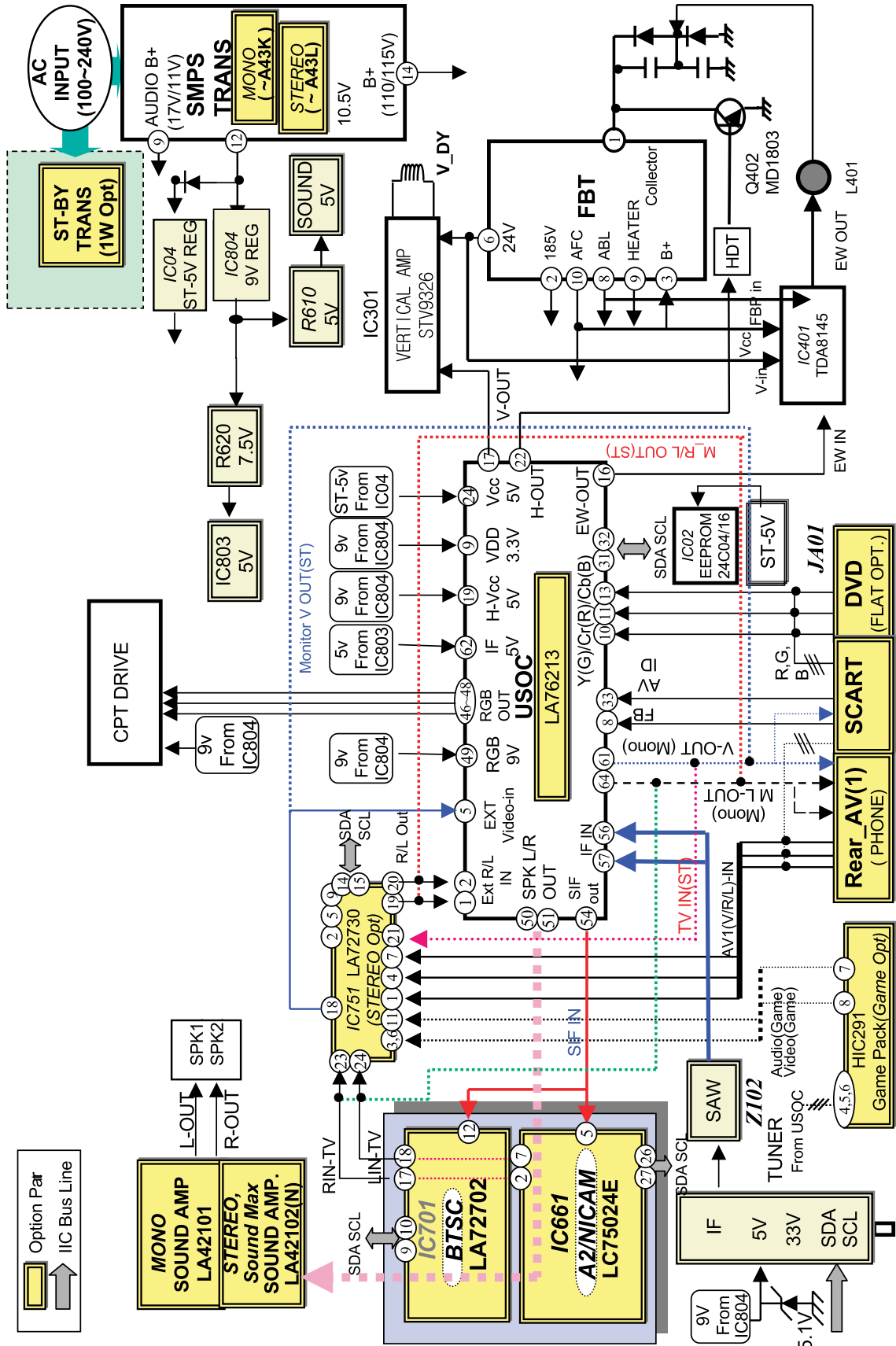

# PRINTED CIRCUIT BOARD

## MAIN

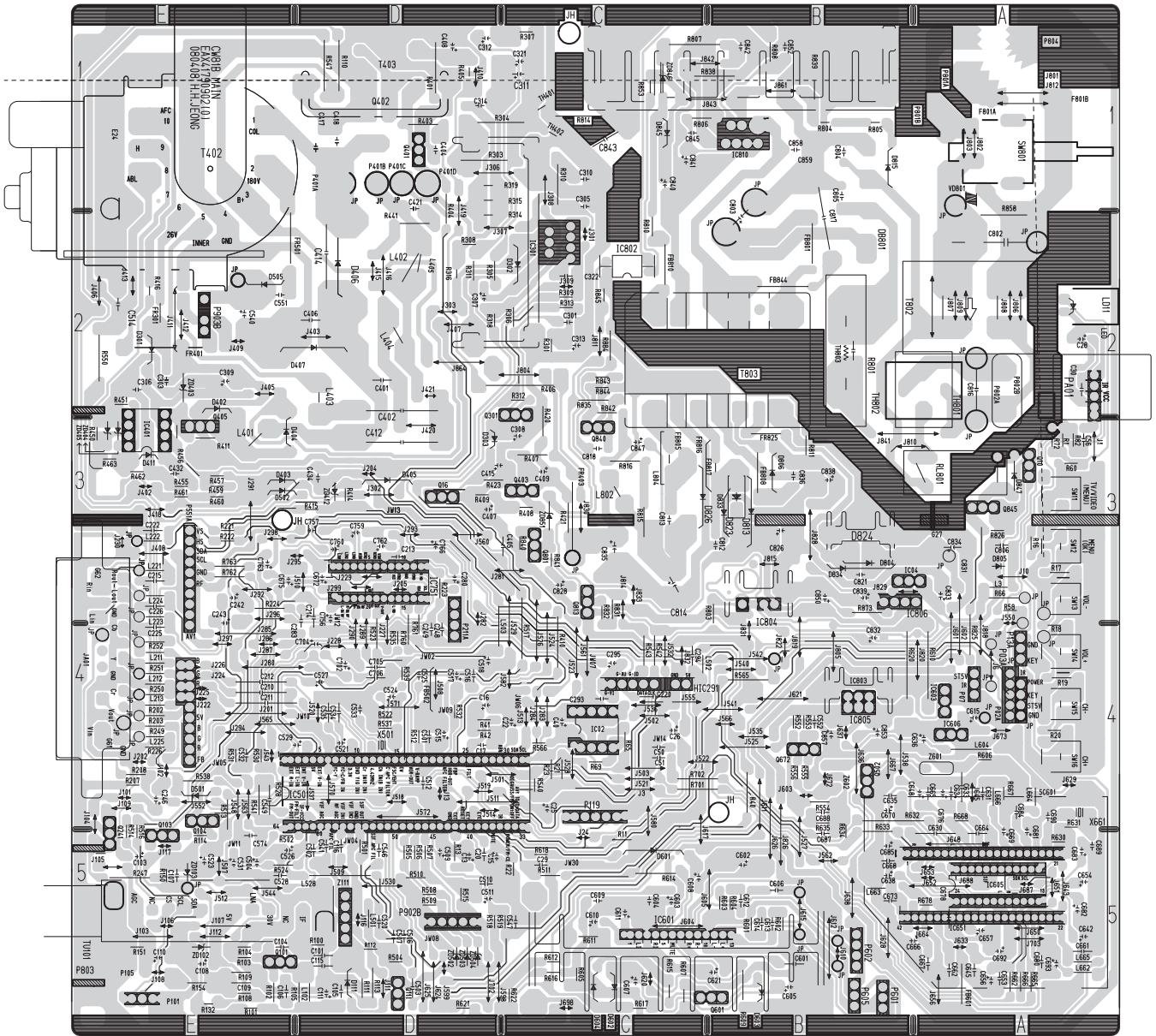

## CONTROL

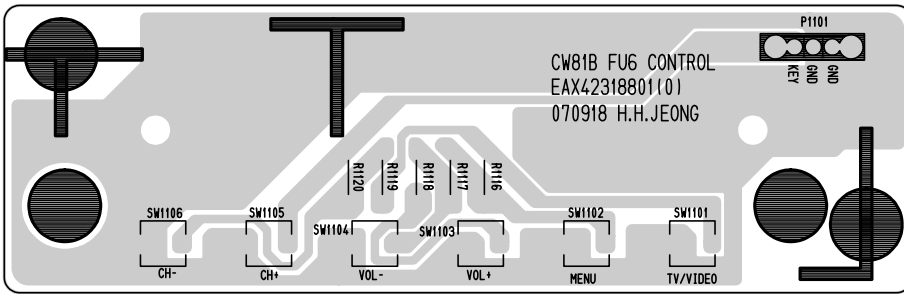

## CPT (option)

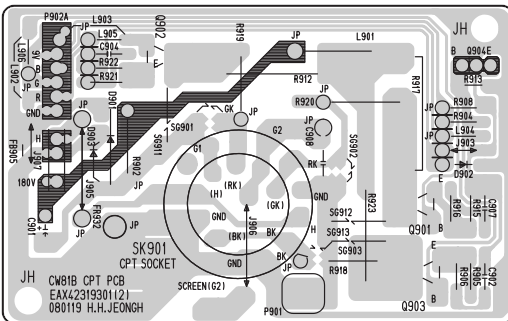

## LED+PRE AMP

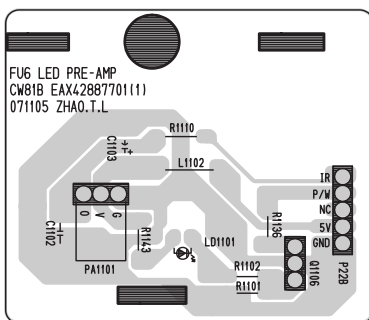

# EXPLODED VIEW

**NOTA IMPORTANTE SOBRE SEGURIDAD**  
 Muchas partes eléctricas y mecánicas en este chasis tienen características relacionadas con la seguridad. Estas partes están identificadas con una marca ⚠ en el Diagrama Esquemático y la VISTA AMPLIADA. Es esencial que esas partes de seguridad se reemplacen con componentes idénticos tal como se recomienda en este manual para evitar RADIACIÓN X, descargas eléctricas, incendios y otros peligros. No modifique el diseño original sin permiso del fabricante.

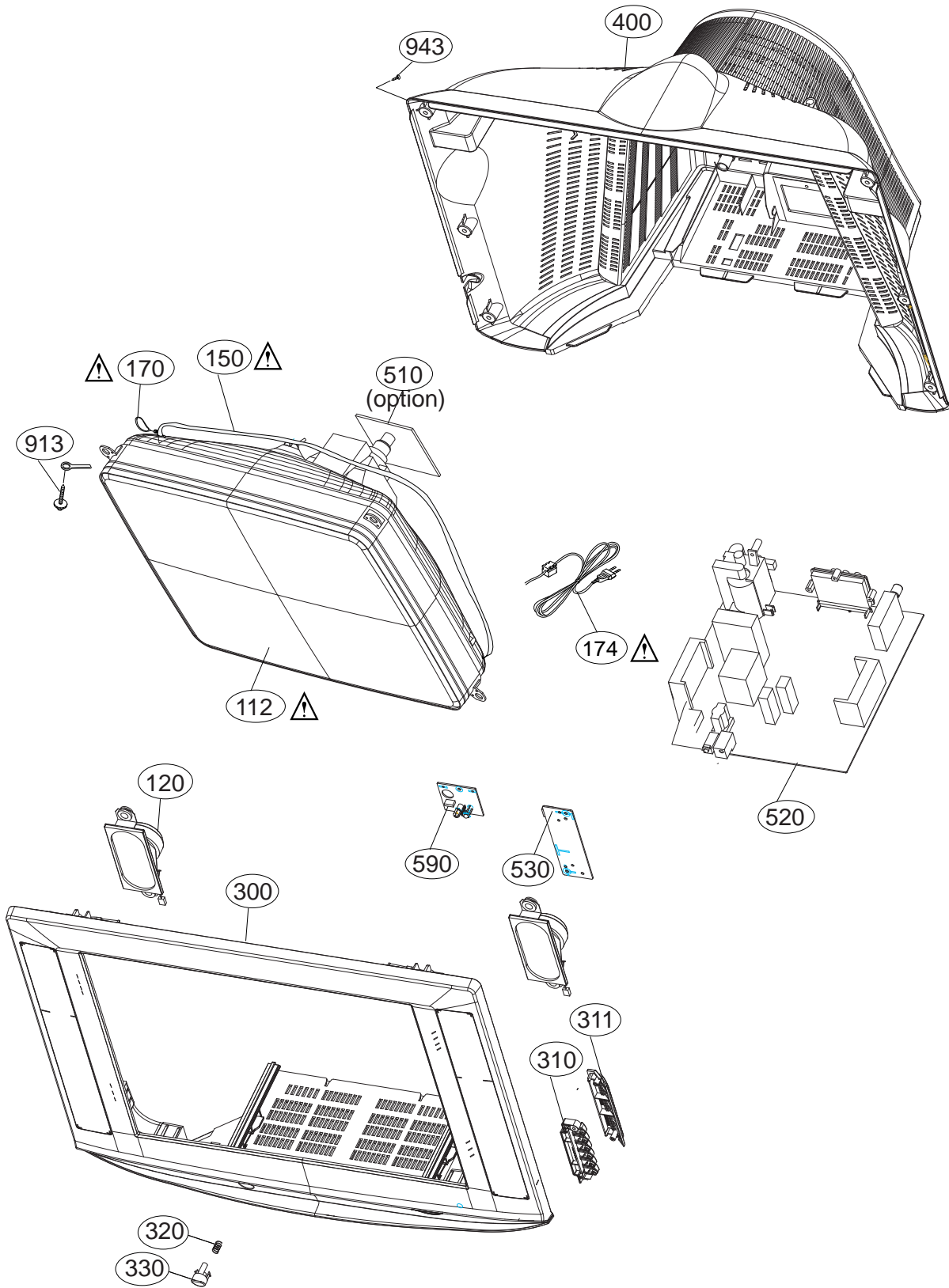

# < SCHEMATIC DIAGRAM OF CW-81B >

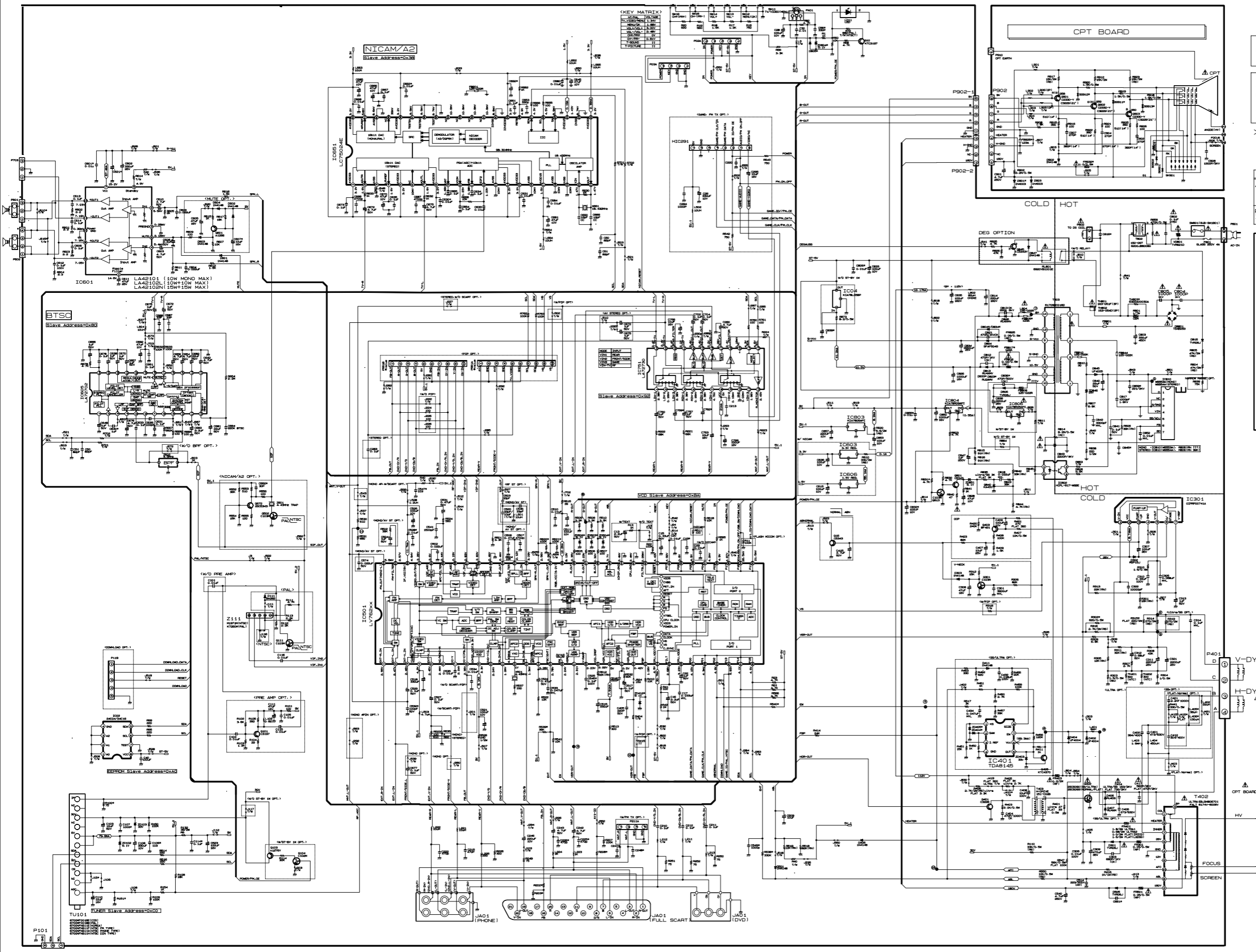

WARNING: BEFORE SERVICING THIS CHASSIS, READ 'X-RAY RADIATION PRECAUTION', 'SAFETY PRECAUTION', AND PRODUCT SAFETY NOTICE IN THIS MANUAL.

CAUTION: THE MARKS IN THE SCHEMATIC DIAGRAM AND THE PARTS LIST DESIGNATE COMPONENTS WHICH HAVE SPECIAL CHARACTERISTICS FOR SAFETY, AND SHOULD BE REPLACED ONLY WITH TYPES IDENTICAL TO THOSE IN THE ORIGINAL CIRCUIT OR SPECIFIED IN THE PARTS LIST. BEFORE REPLACING ANY OF THESE COMPONENTS, READ CAREFULLY THE PRODUCT SAFETY NOTICE IN THIS MANUAL. DO NOT DEGRADE THE SAFETY OF THE RECEIVER THROUGH IMPROPER SERVICING.

\* : OPTION

< IC VERSION >

\* ASSEMBLE SUBCIC(AV/ST)IC WITH RF/ST IC FOR RF/ST MODEL

SOUND IC	SYSTEM	COMB	EW	TXT	Surround	A2+NICAM	BTSC
AV-ST LV76213	PAL/NT	X	●	X	●	●	●
LV76223	PAL/NT/SECAM	X	●	X	●	●	●
LV76233	PAL/NT/SECAM	X	●	●	●	●	●
RF-ST LC75024	A2/NICAM					●	X
IC LA72702NB	BTSC						●

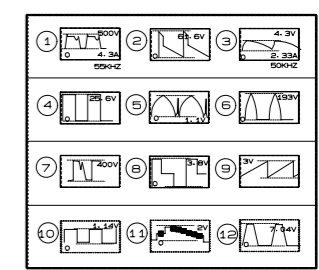
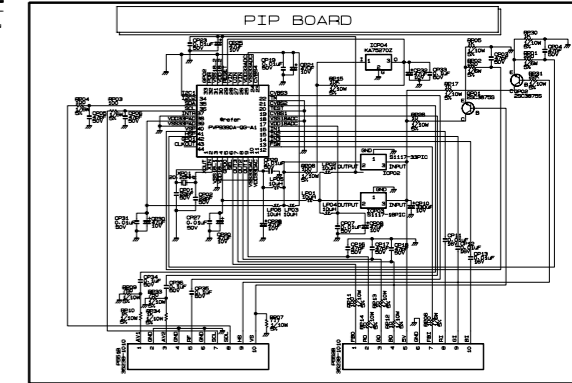

IC301		
Standard	Adjust	Stand-by
① 2.25V	① 2.26V	① 34.6mV
② 29.55V	② 29.8V	② 0.25V
③ 1.63V	③ 0.64V	③ 0.4mV
④ 3.4mV	④ 9.6mV	④ 0.3mV
⑤ 14.97V	⑤ 15.3V	⑤ 0.24V
⑥ 29.43V	⑥ 29.1V	⑥ 1.4V
⑦ 2.25V	⑦ 2.25V	⑦ 10.7mV

IC401		
Standard	Adjust	Stand-by
① 8.42V	① 8.46V	① 0.22V
② 4.89V	② 4.96V	② 0.23mV
③ 8.42V	③ 8.46V	③ 0.23mV
④ 4.4mV	④ 1.4mV	④ 0.23V
⑤ 11.9V	⑤ 1.09V	⑤ 0.55V
⑥ 29.59V	⑥ 29.8V	⑥ 0.25V
⑦ 2.89V	⑦ 3.5V	⑦ 0.76V
⑧ 2.85V	⑧ 2.86V	⑧ 0.2mV

**SVC. SHEET : 3854VA0196D-S**