

This part must be placed near the tuner

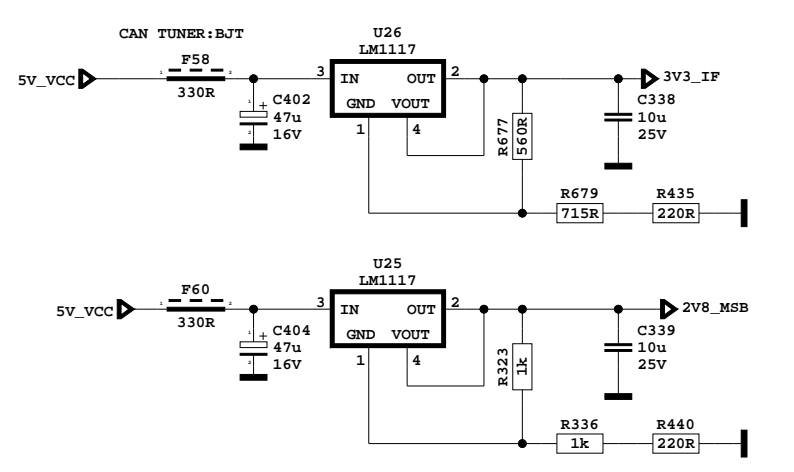

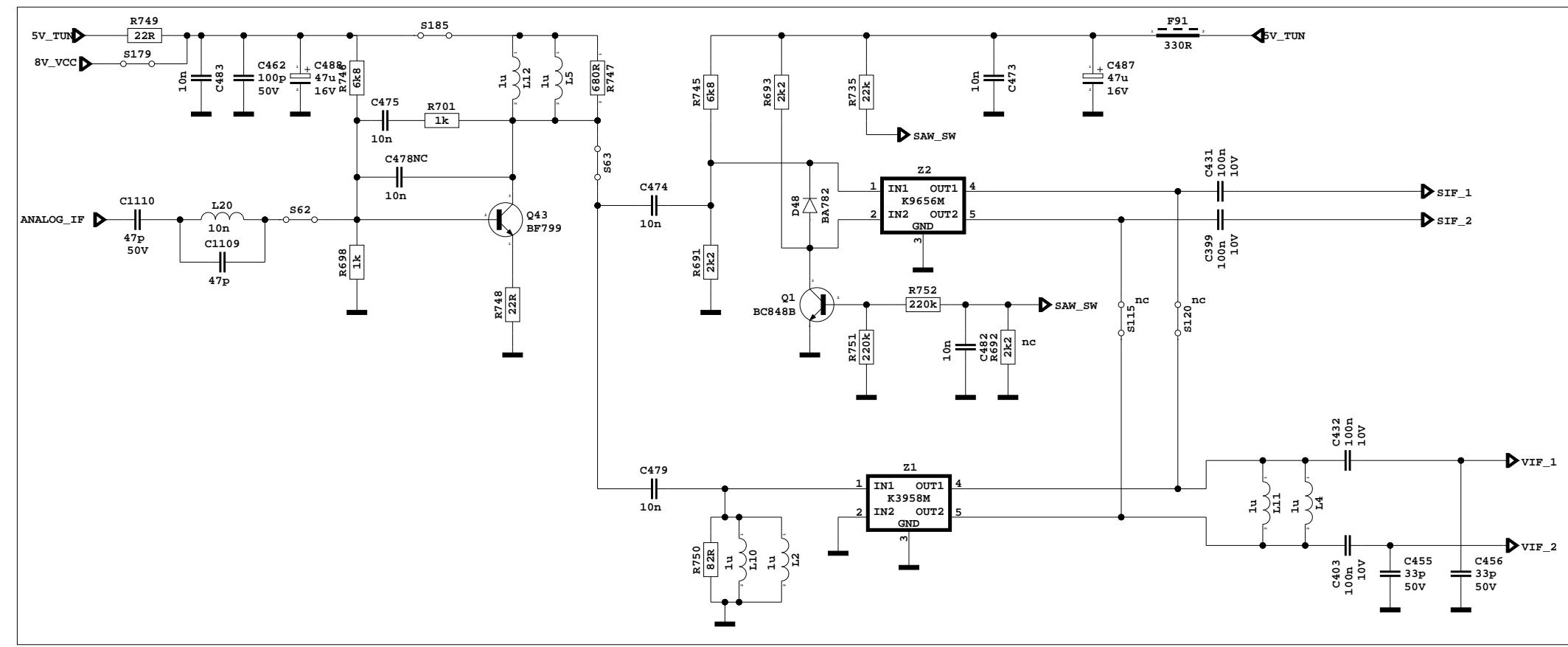

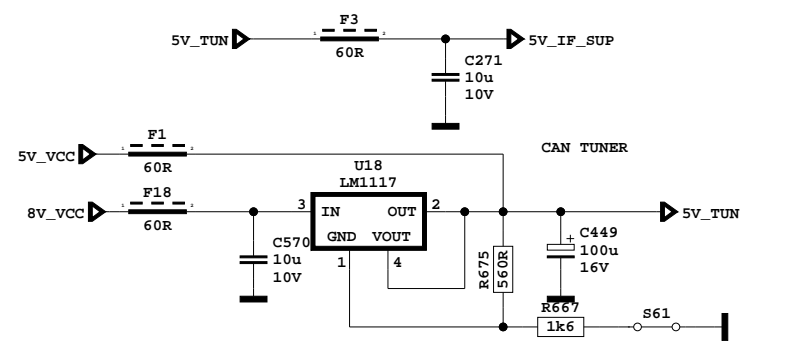

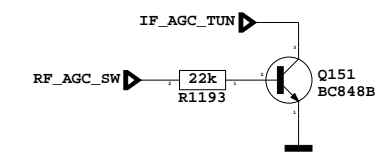
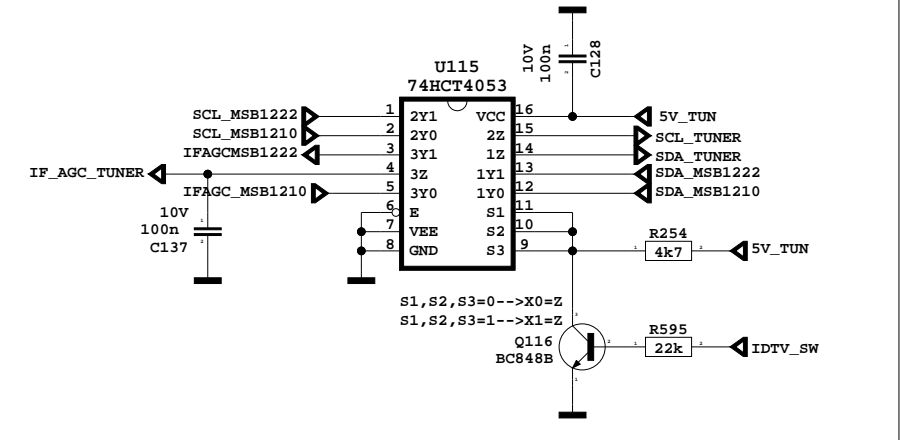
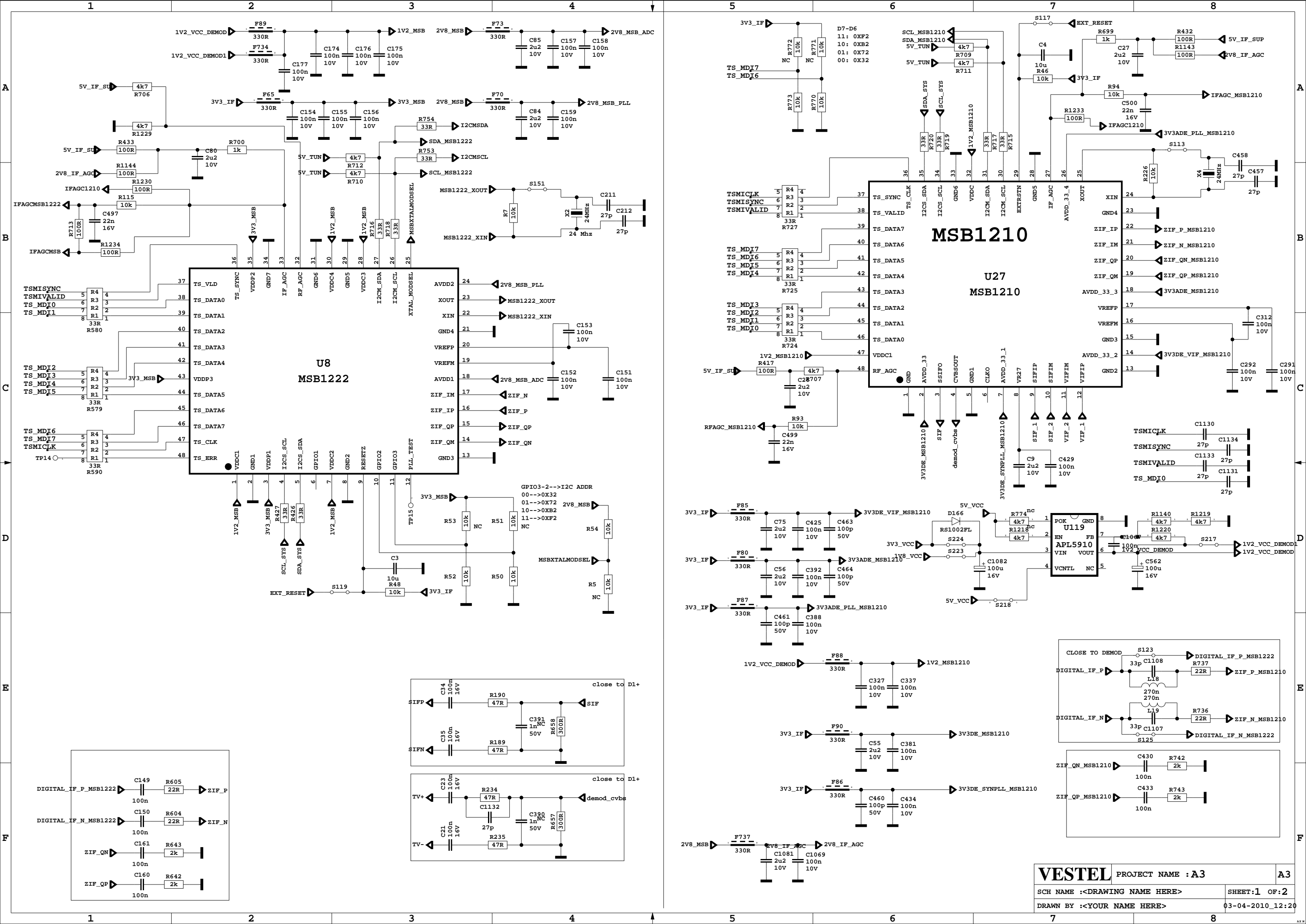
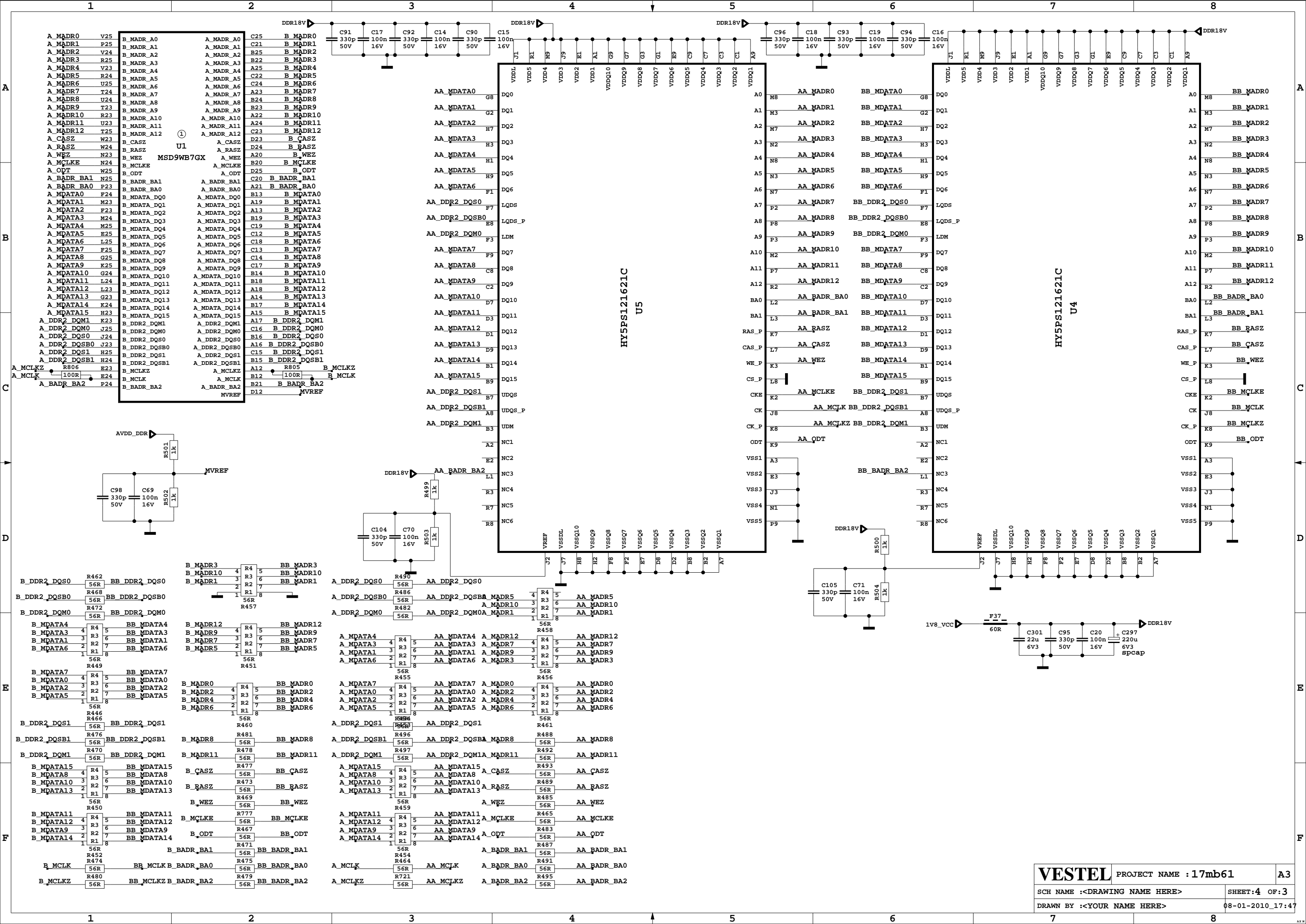
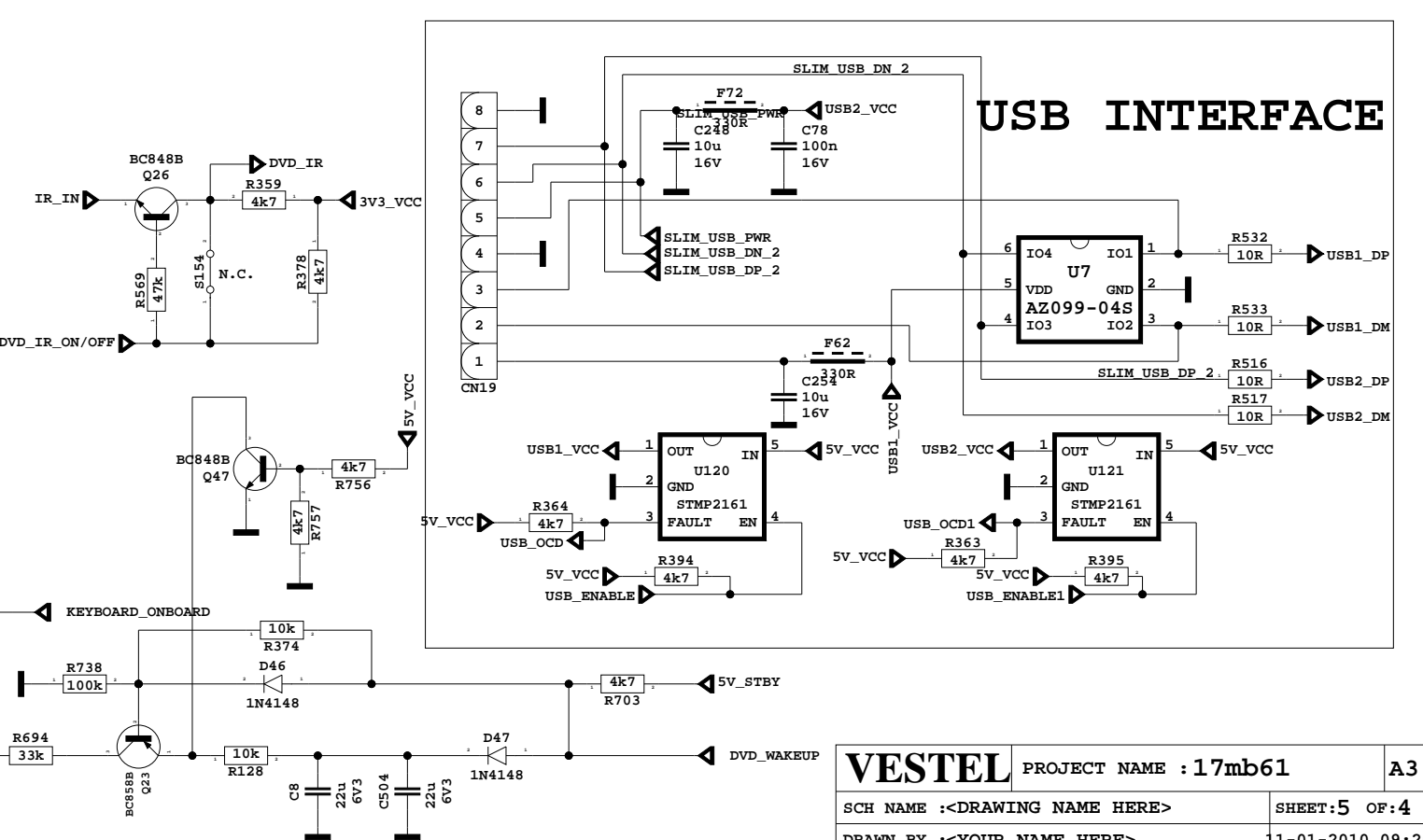
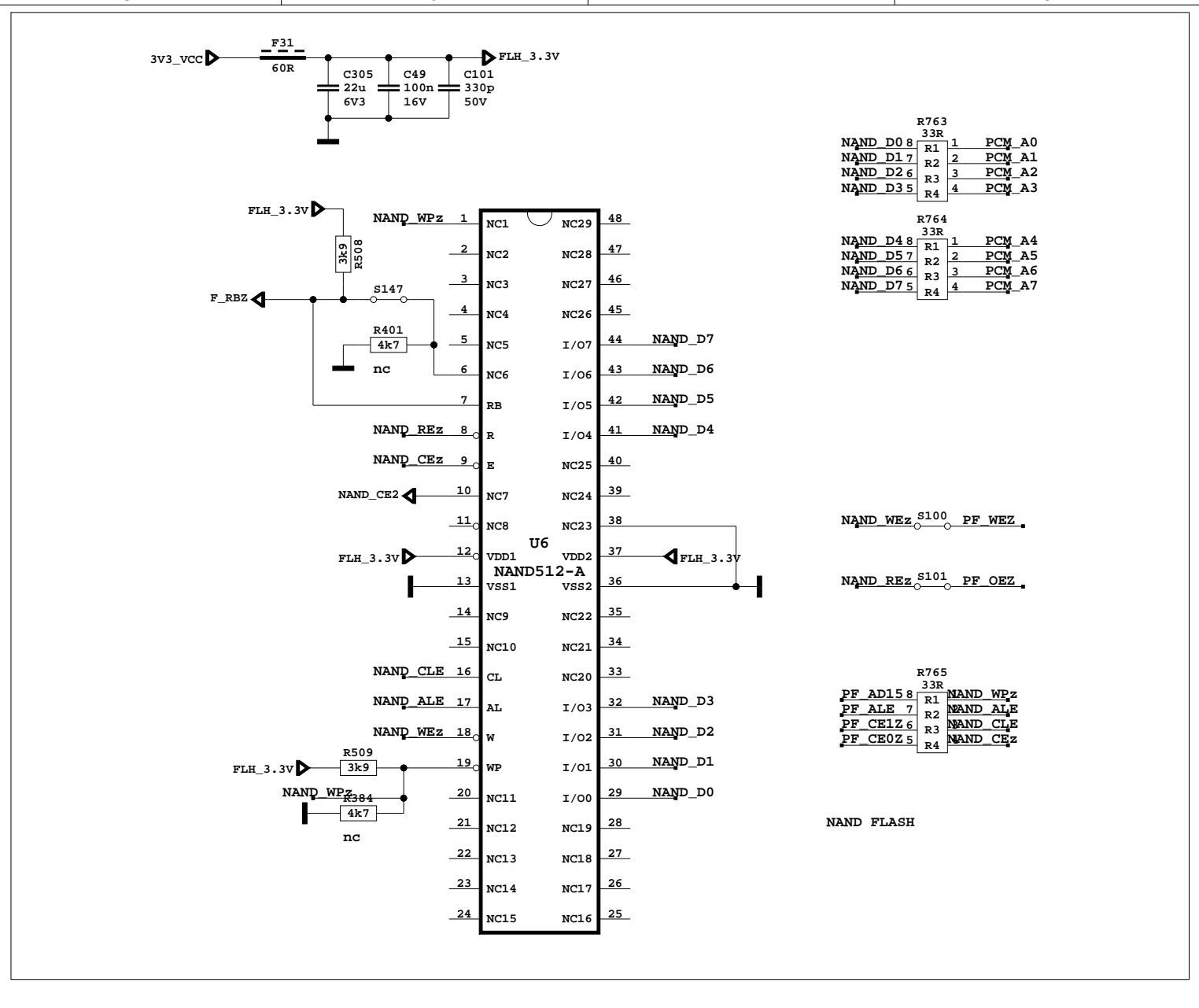
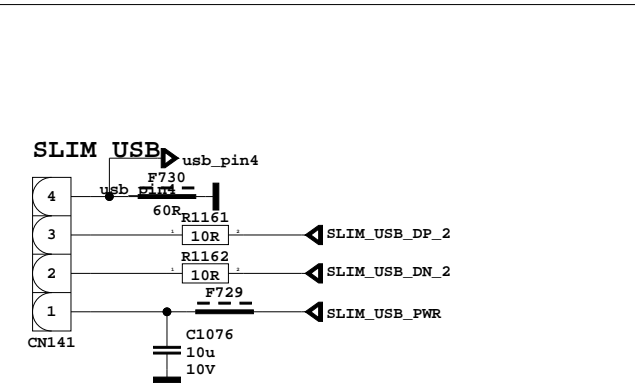
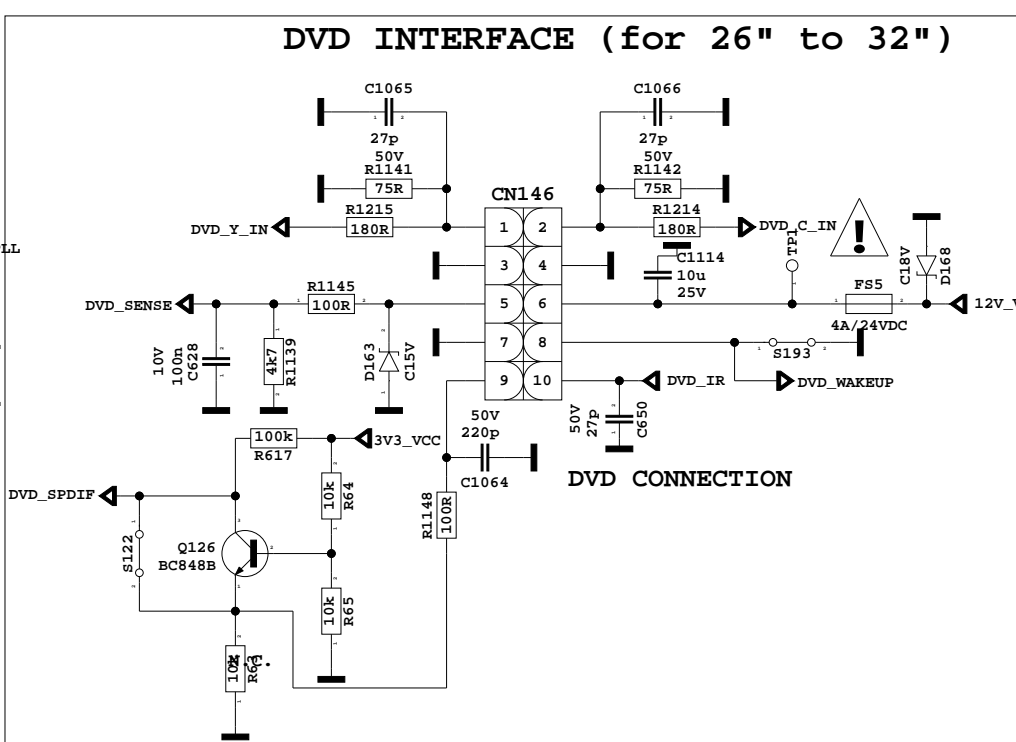
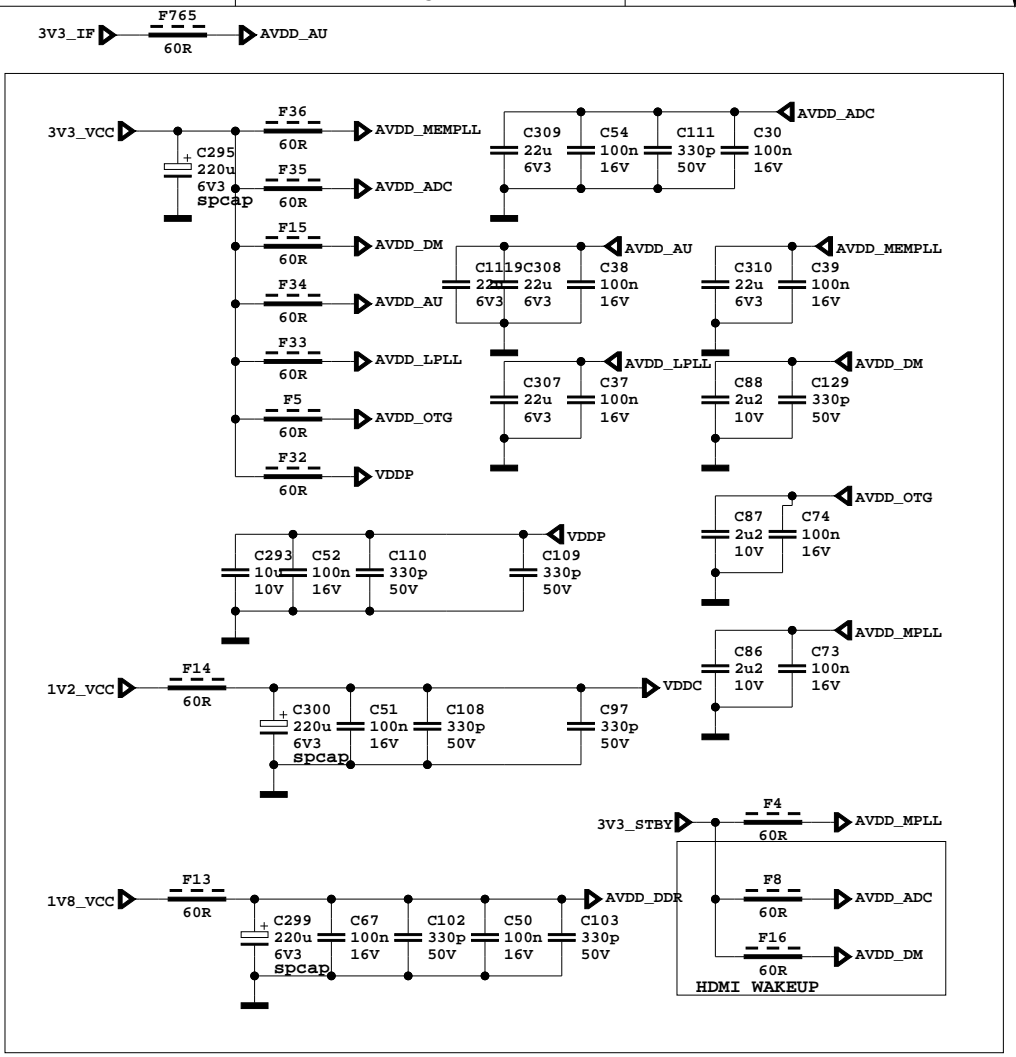
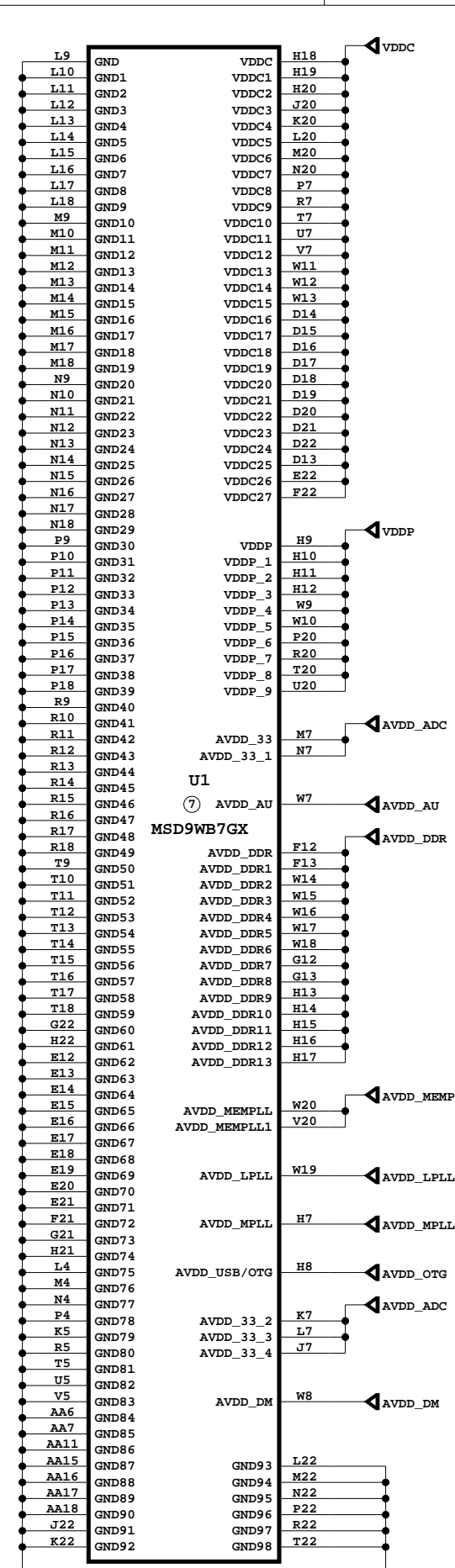

CI INTERFACE

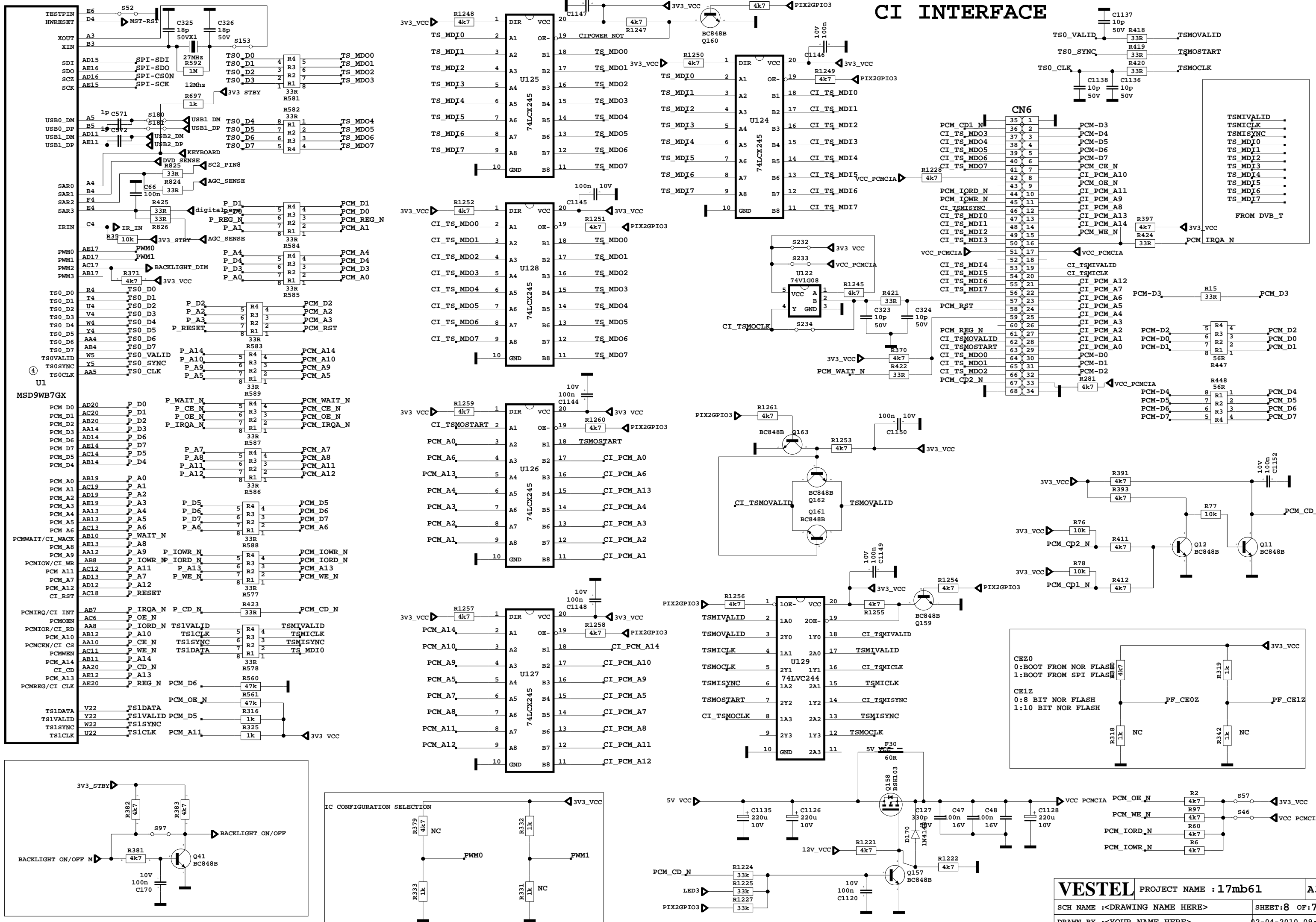

19" TO 22" FFC OPTIONS

26" UT FFC OPTIONS

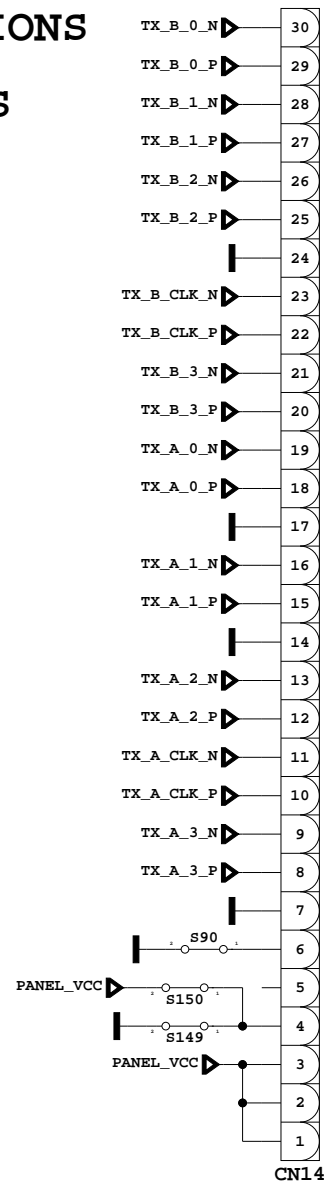

LVDS CABLE

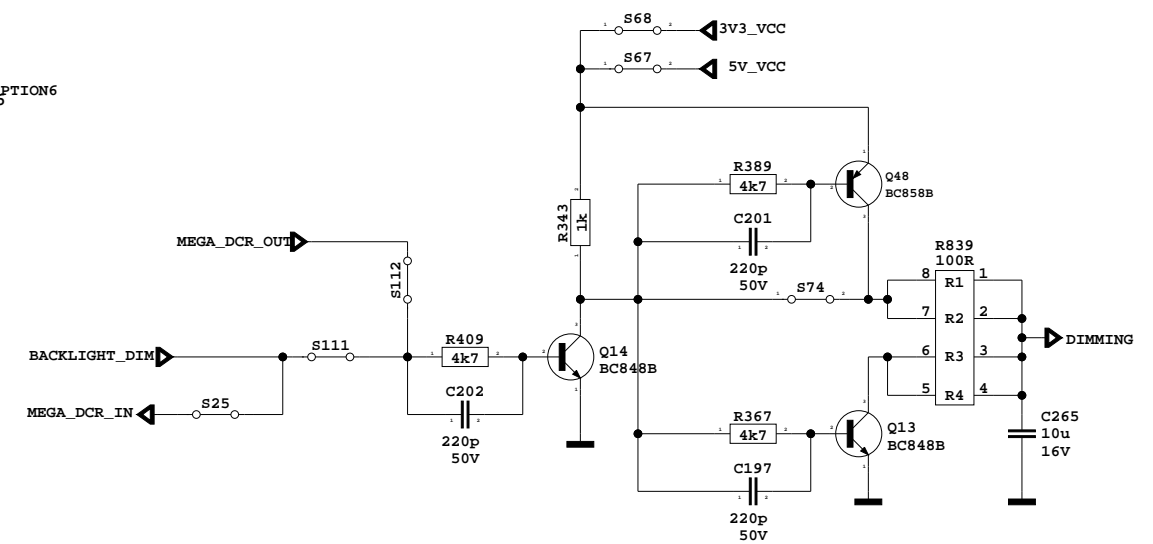
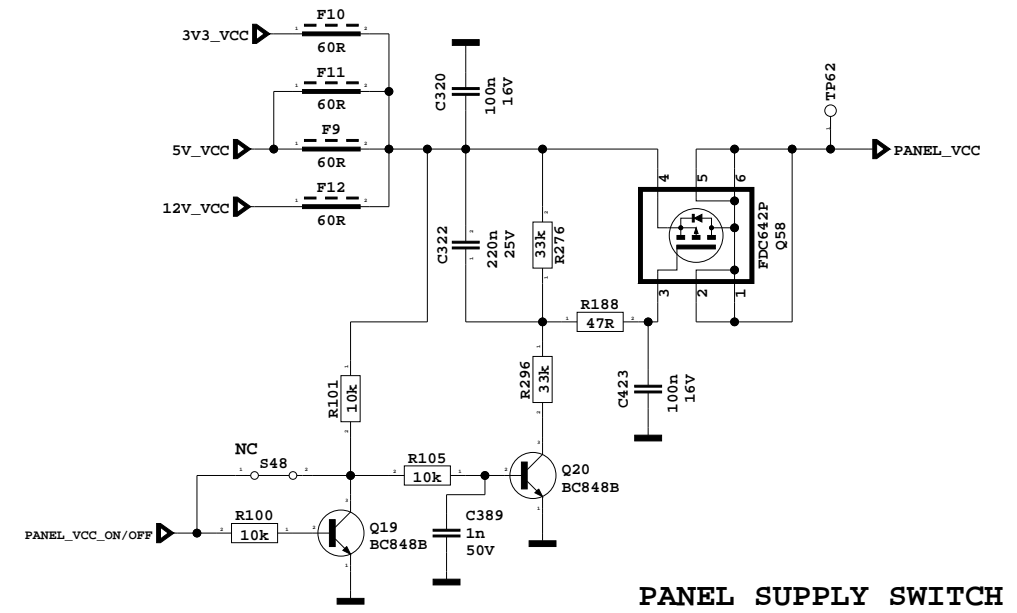
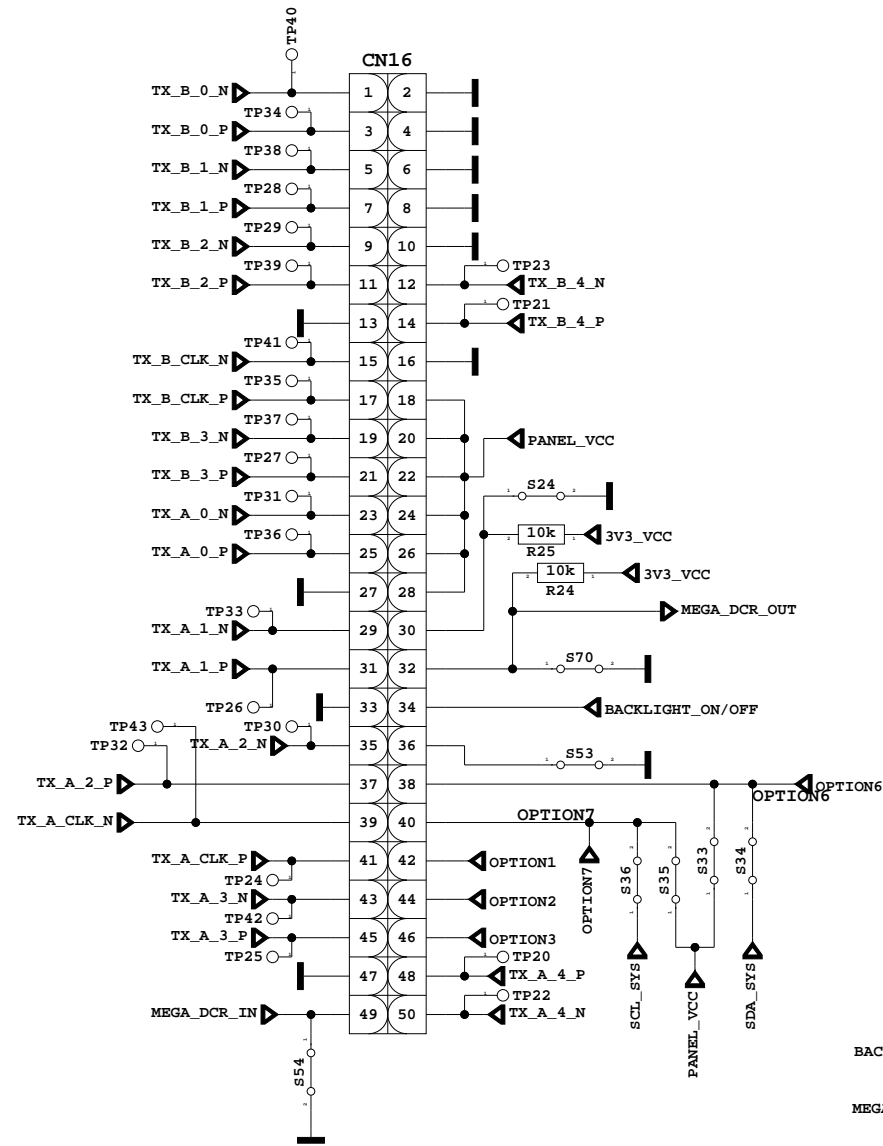

SINGLE LVDS FFC OPTIONS

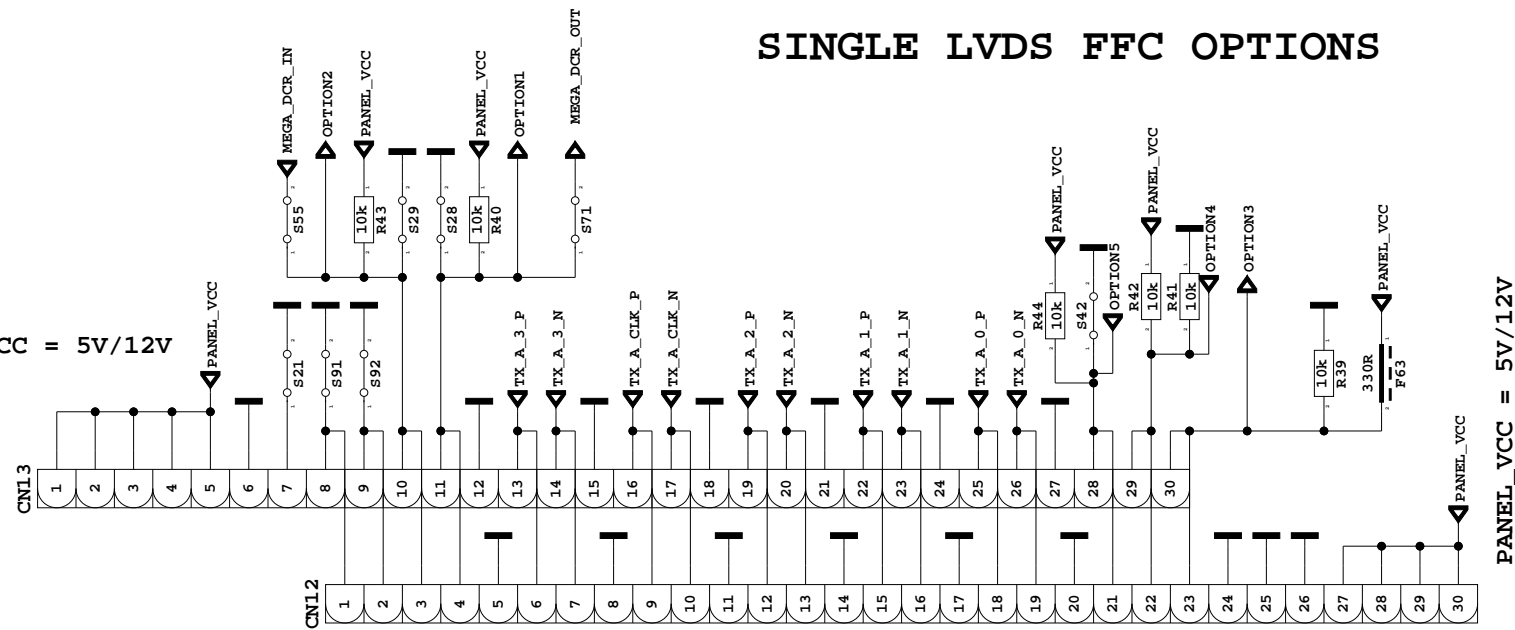

PANEL_VCC = 5V/12V

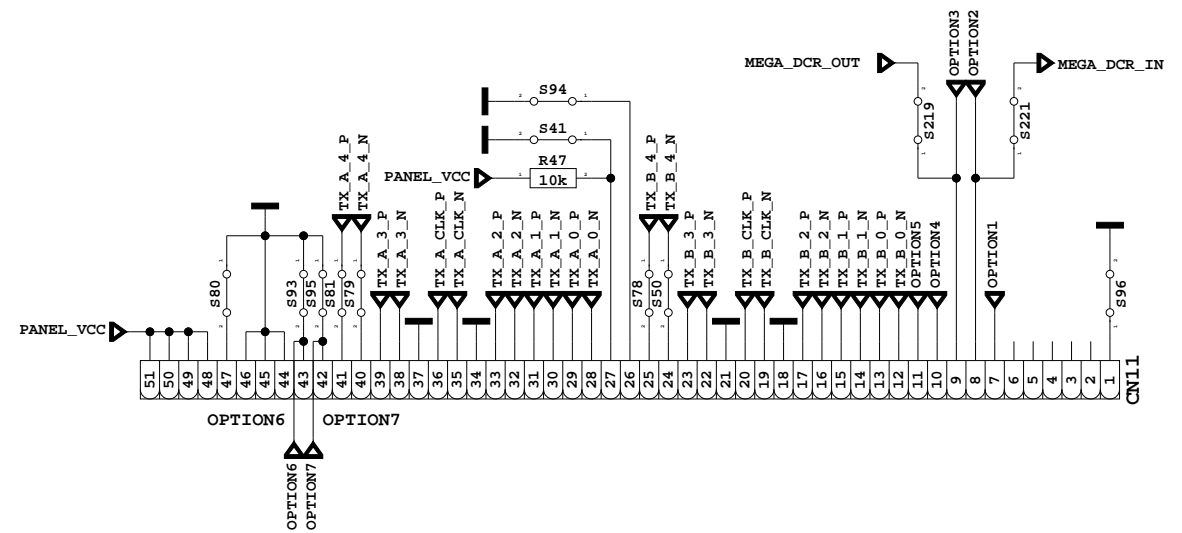

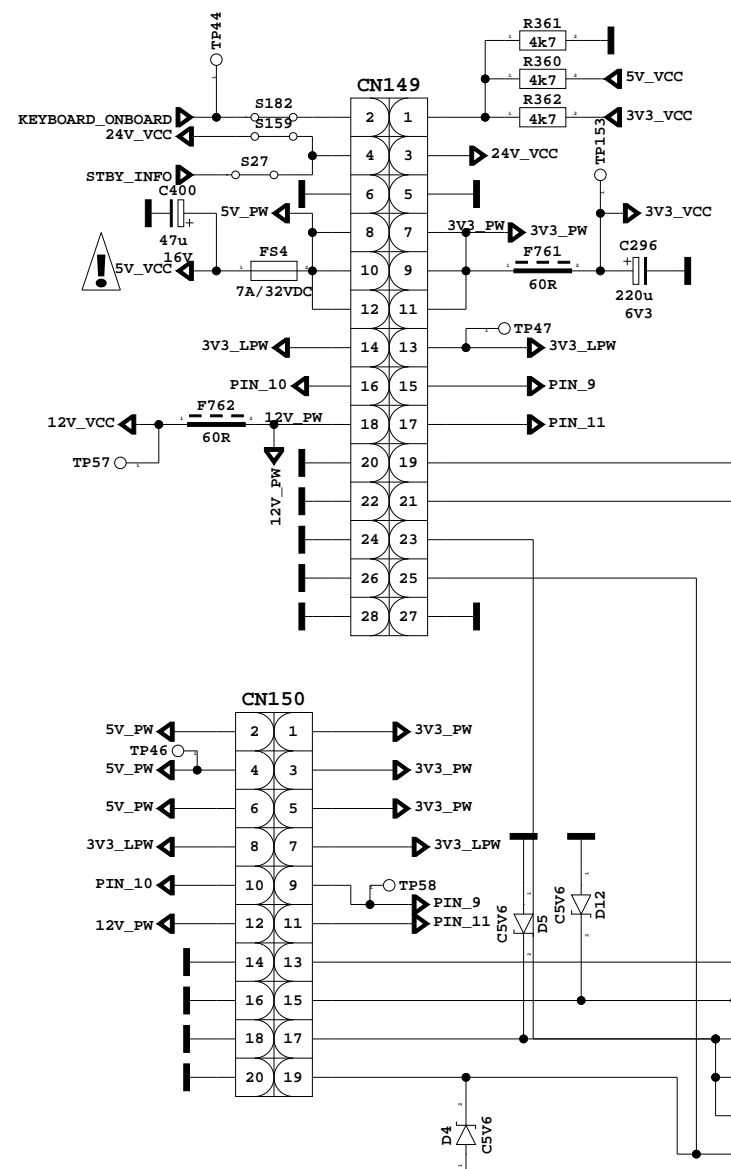

17IPS15 CONNECTOR

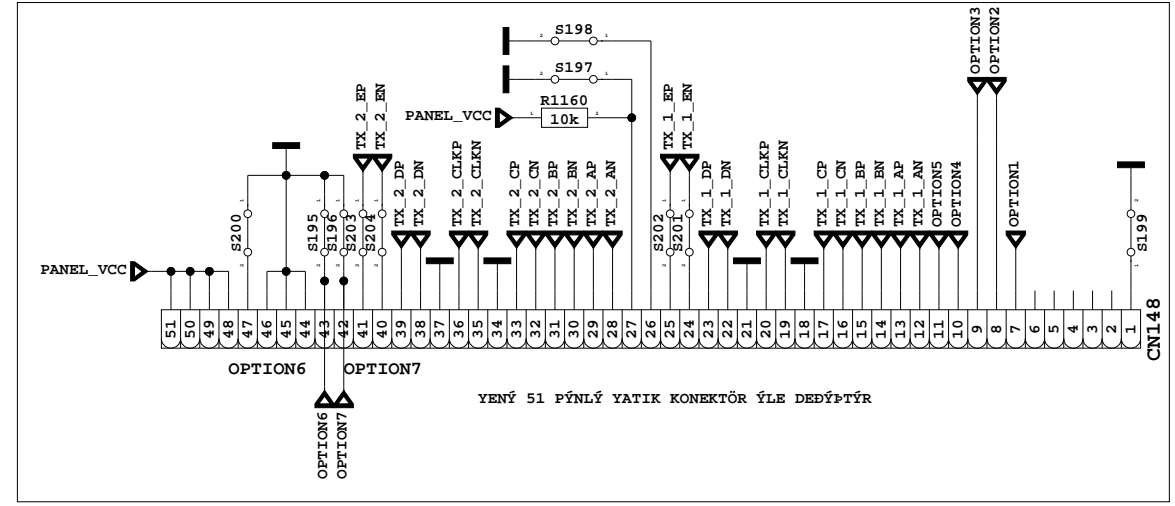
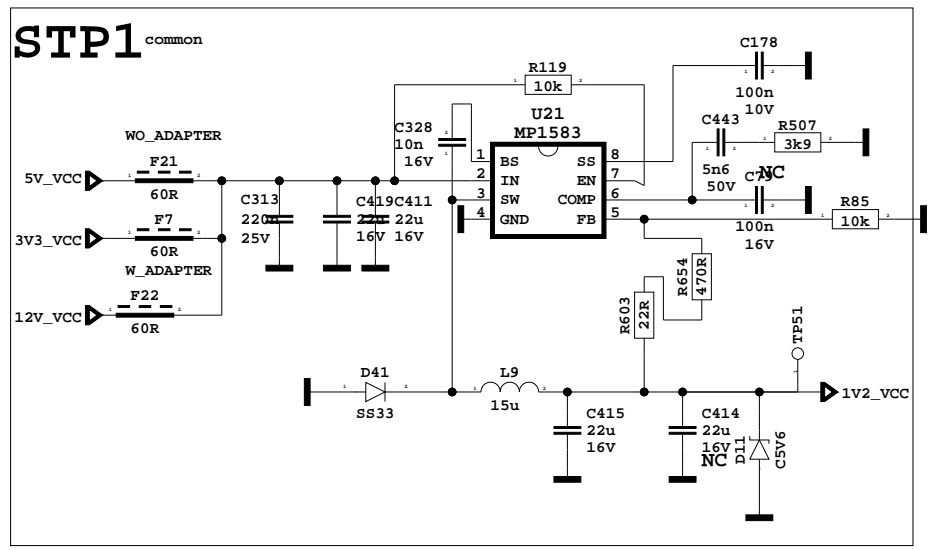
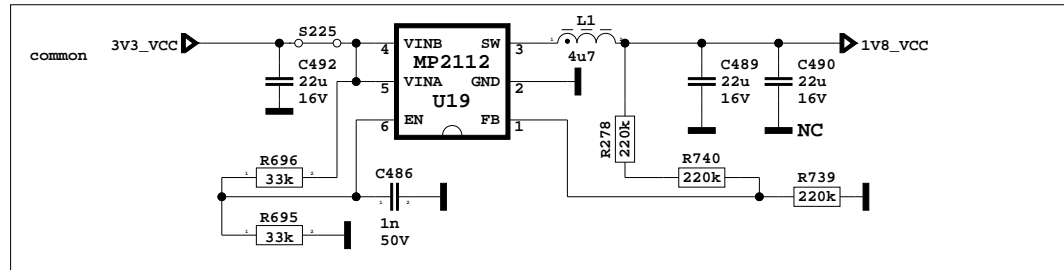
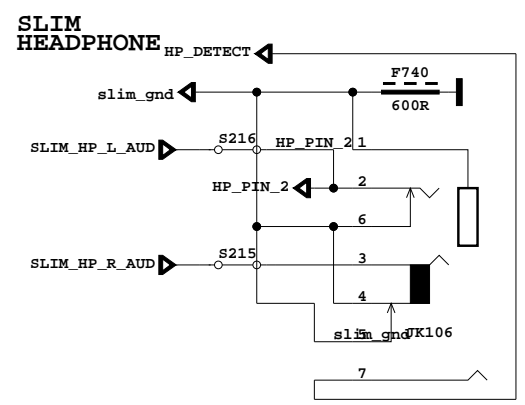
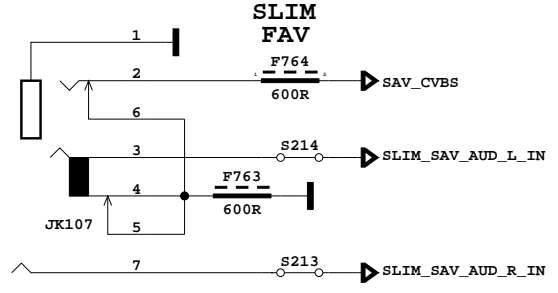
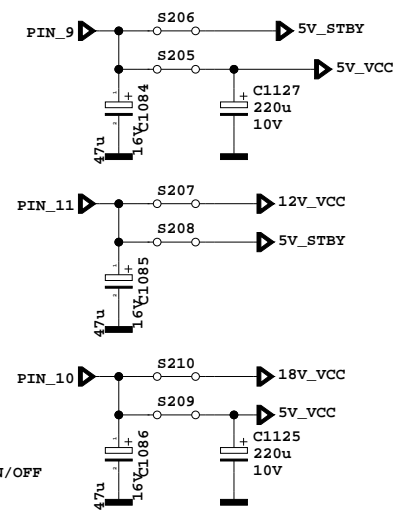
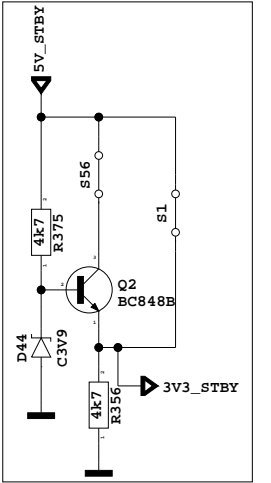
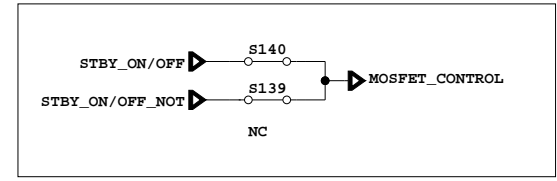
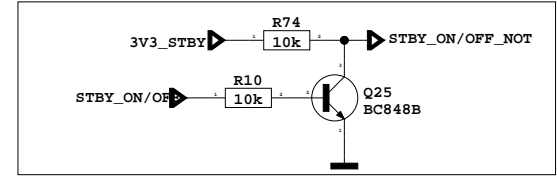
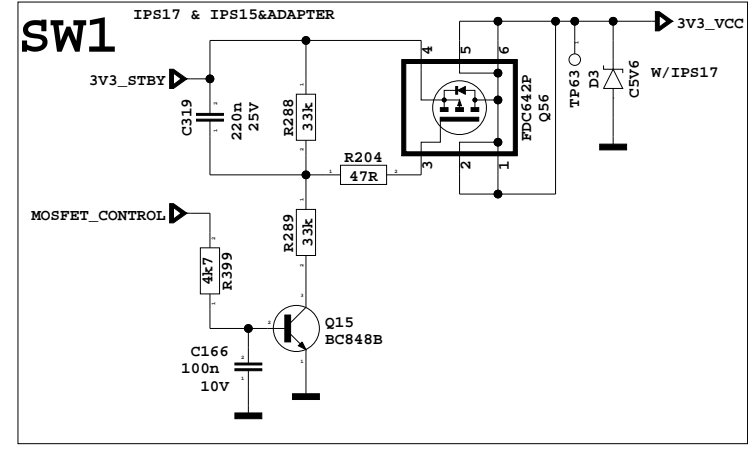
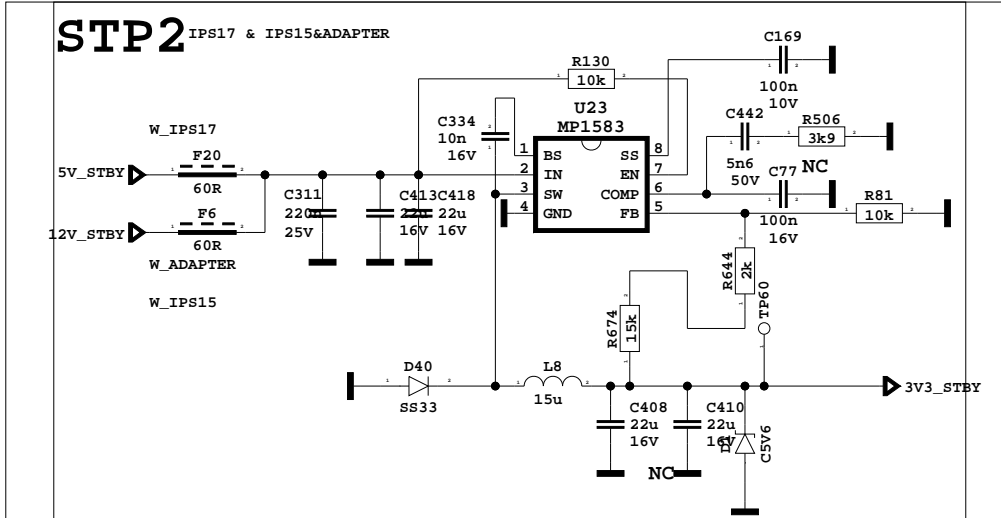

YENÝ 51 PÝNLÝ YATIK KONEKTÖR ÝLE DEĐÝPTÝR

