

Service Manual

Portable Stereo CD System

Model No. **RX-D55EE**

Product Color: (K)...Black Type



Remote Control



RX-D55

Notes: This model is based on RX-D55EG-K. Please refer to the original service manual (Order no. PSG1004005CE).

⚠ WARNING

This service information is designed for experienced repair technicians only and is not designed for use by the general public. It does not contain warnings or cautions to advise non-technical individuals of potential dangers in attempting to service a product. Products powered by electricity should be serviced or repaired only by experienced professional technicians. Any attempt to service or repair the product or products dealt with in this service information by anyone else could result in serious injury or death.

IMPORTANT SAFETY NOTICE

There are special components used in this equipment which are important for safety. These parts are marked by ⚠ in the Schematic Diagrams, Circuit Board Diagrams, Exploded Views and Replacement Parts List. It is essential that these critical parts should be replaced with manufacturer's specified parts to prevent shock, fire or other hazards. Do not modify the original design without permission of manufacturer.

TABLE OF CONTENTS

	PAGE		PAGE
1 Safety Precautions -----	3	2.4. Handling Precaution for Traverse Unit-----	8
1.1. General Guidelines-----	3	3 Service Navigation -----	10
1.2. Before Repair and Adjustment-----	4	3.1. Service Information-----	10
1.3. Caution For Fuse Replacement-----	4	3.2. Notes-----	10
1.4. Protection Circuitry-----	4	3.3. Different Points-----	11
1.5. Safety Part Information-----	4	4 Specifications -----	12
2 Warning -----	5	5 Illustration of IC's, Transistors and Diodes -----	13
2.1. Prevention of Electro Static Discharge (ESD) to Electrostatically Sensitive (ES) Devices-----	5	6 Schematic Diagram -----	15
2.2. Precaution of Laser Diode-----	6	6.1. MAIN CIRCUIT (1/6)-----	15
2.3. Service caution based on Legal restrictions-----	7	6.2. MAIN CIRCUIT (2/6)-----	16
		6.3. MAIN CIRCUIT (3/6)-----	17

Panasonic®

© Panasonic Corporation 2010. All rights reserved.
Unauthorized copying and distribution is a violation of law.

6.4. MAIN CIRCUIT (4/6)	18
6.5. MAIN CIRCUIT (5/6)	19
6.6. MAIN CIRCUIT (6/6)	20
6.7. POWER CIRCUIT	21
7 Printed Circuit Board	22
7.1. MAIN P.C.B.	22
7.2. DECK P.C.B.	23
7.3. POWER, BATTERY (1), BATTERY (2) & MUSIC PORT P.C.B.	24
8 Exploded View and Replacement Parts List	25
8.1. Exploded View and Mechanical replacement Parts List	25
8.2. Electrical Replacement Parts List	31

1 Safety Precautions

1.1. General Guidelines

1. When servicing, observe the original lead dress. If a short circuit is found, replace all parts which have been overheated or damaged by the short circuit.
2. After servicing, see to it that all the protective devices such as insulation barriers, insulation papers shields are properly installed.
3. After servicing, carry out the following leakage current checks to prevent the customer from being exposed to shock hazards.

1.1.1. Leakage Current Cold Check

1. Unplug the AC cord and connect a jumper between the two prongs on the plug.
2. measure the resistance value, with an ohmmeter between the jumpered AC plug and each exposed metallic cabinet part on the equipment such as screwheads, connectors, control shafts, etc. When the exposed metallic part has a return path to the chassis, the reading should be between $1M\Omega$ and $5.2M\Omega$. When the exposed metal does not have a return path to the chassis, the reading must be ∞

1.1.2. Leakage Current Hot Check

1. Plug the AC cord directly into the AC outlet. Do not use an isolation transformer for this check.
2. Connect a $1.5k\Omega$, 10 watts resistor, in parallel with a $0.15\mu F$ capacitors, between each exposed metallic part on the set and a good earth ground such as a water pipe, as shown in Figure 1.
3. Use an AC voltmeter, with 1000 ohms/volt or more sensitivity, to measure the potential across the resistor.
4. Check each exposed metallic part, and measure the voltage at each point.
5. Reverse the AC plug in the AC outlet and repeat each of the above measurements.
6. The potential at any point should not exceed 0.75 volts RMS. A leakage current tester (Simpson Model 229 or equivalent) may be used to make the hot checks, leakage current must not exceed 1/2 milliamp. In case a measurement is outside of the limits specified, there is a possibility of a shock hazard, and the equipment should be repaired and rechecked before it is returned to the customer.

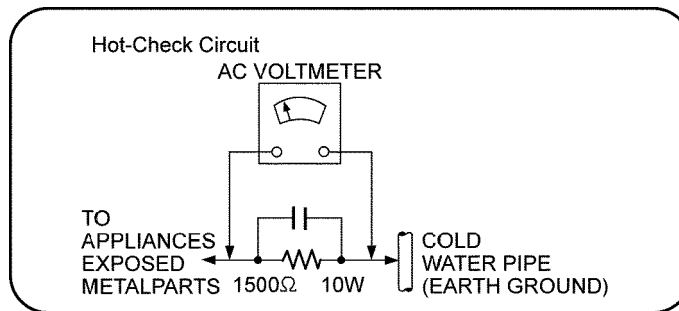

Figure. 1

1.2. Before Repair and Adjustment

Caution : DO NOT SHORT-CIRCUIT DIRECTLY (with a screwdriver blade, for instance), as this may destroy solid state devices. After repairs are completed, restore power gradually using a variac, to avoid overcurrent.

- Current consumption at AC 230V, 50Hz in TUNER mode at volume (min) should be (~300 mA).

1.3. Caution For Fuse Replacement

CAUTION:

Replace with the same type fuse:

(Manufacturer: Littelfuse Inc., Type: 218, F5901, T4AL, 250V)

(Manufacturer: Littelfuse Inc., Type: 218, F5902, T1.6AL, 250V)

1.4. Protection Circuitry

The protection circuitry may have operated if either of the following conditions are noticed:

- No sound is heard when the power is turned on.
- Sound stops during a performance.

The function of this circuitry is to prevent circuitry damage if, for example, the positive and negative speaker connection wires are "shorted", or if speaker systems with an impedance less than the indicated rated impedance of the amplifier are used.

If this occurs, follow the procedure outlines below:

1. Turn off the power.
2. Determine the cause of the problem and correct it.
3. Turn on the power once again after one minute.

Note:

When the protection circuitry functions, the unit will not operate unless the power is first turned off and then on again.

1.5. Safety Part Information

Safety Parts List:

There are special components used in this equipment which are important for safety.

These parts are marked by \triangle in the Schematic Diagrams, Exploded View & Replacement Parts List. It is essential that these critical parts should be replaced with manufacturer's specified parts to prevent shock, fire or other hazards. Do not modify the original design without permission of manufacturer.

Table 1

Safety	Ref. No.	Part No.	Part Name & Description	Remarks
\triangle	14	RKHN0005B-H	HANDLE	
\triangle	401	RD-DAPX001-V	TRAVERSE UNIT	
\triangle	A2	K2CQ2CA00007	AC CORD	
\triangle	A3	RQTX1037-R	O/I BOOK (Ru/Ur)	
\triangle	PCB3	REPNT0063H	POWER P.C.B.	(RTL)
\triangle	L5901	ELF15N035AN	LINE FILTER	
\triangle	T5903	G4C5ACH00007	TRANSFORMER	
\triangle	Z5902	ERZVA5Z471	ZNR SURGE	
\triangle	F5901	K5D402BLA013	FUSE	
\triangle	F5902	K5D162BLA013	FUSE	
\triangle	FP4100	K5G502A00039	FUSE PROTECTOR	
\triangle	FP5903	K5G502A00039	FUSE PROTECTOR	
\triangle	JK5901	K2AA2B000014	AC INLET	
\triangle	ZA5901	K3GE1ZZ00001	FUSE HOLDER	
\triangle	ZA5902	K3GE1ZZ00001	FUSE HOLDER	
\triangle	ZA5903	K3GE1ZZ00001	FUSE HOLDER	
\triangle	ZA5904	K3GE1ZZ00001	FUSE HOLDER	
\triangle	R4149	D0AF1R5JA113	1.5 1/8W	
\triangle	R4153	D0AF1R5JA113	1.5 1/8W	
\triangle	R4154	D0AF1R5JA113	1.5 1/8W	

2 Warning

2.1. Prevention of Electro Static Discharge (ESD) to Electrostatically Sensitive (ES) Devices

Some semiconductor (solid state) devices can be damaged easily by static electricity. Such components commonly are called Electrostatically Sensitive (ES) Devices. Examples of typical ES devices are integrated circuits and some field-effect transistors and semiconductor “chip” components. The following techniques should be used to help reduce the incidence of component damage caused by electrostatic discharge (ESD).

1. Immediately before handling any semiconductor component or semiconductor-equipped assembly, drain off any ESD on your body by touching a known earth ground. Alternatively, obtain and wear a commercially available discharging ESD wrist strap, which should be removed for potential shock reasons prior to applying power to the unit under test.
2. After removing an electrical assembly equipped with ES devices, place the assembly on a conductive surface such as aluminium foil, to prevent electrostatic charge build up or exposure of the assembly.
3. Use only a grounded-tip soldering iron to solder or unsolder ES devices.
4. Use only an anti-static solder remover device. Some solder removal devices not classified as “anti-static (ESD protected)” can generate electrical charge sufficient to damage ES devices.
5. Do not use freon-propelled chemicals. These can generate electrical charges sufficient to damage ES devices.
6. Do not remove a replacement ES device from its protective package until immediately before you are ready to install it. (Most replacement ES devices are packaged with leads electrically shorted together by conductive foam, aluminium foil or comparable conductive material).
7. Immediately before removing the protective material from the leads of a replacement ES device, touch the protective material to the chassis or circuit assembly into which the device will be installed.

Caution :

Be sure no power is applied to the chassis or circuit, and observe all other safety precautions.

8. Minimize bodily motions when handling unpackaged replacement ES devices. (Otherwise harmless motion such as the brushing together of your clothes fabric or the lifting of your foot from a carpeted floor can generate static electricity (ESD) sufficient to damage an ES device).

2.2. Precaution of Laser Diode

CAUTION!

THIS PRODUCT UTILIZES A LASER.
USE OF CONTROLS OR ADJUSTMENTS OR PERFORMANCE OF PROCEDURES OTHER THAN THOSE SPECIFIED HEREIN MAY RESULT IN HAZARDOUS RADIATION EXPOSURE.

Caution:

This product utilizes a laser diode with the unit turned "on", invisible laser radiation is emitted from the pickup lens.

Wavelength: 795 nm (CD)

Maximum output radiation power from pickup: 100 μ W/VDE

Laser radiation from the pickup unit is safety level, but be sure the followings:

1. Do not disassemble the pickup unit, since radiation from exposed laser diode is dangerous.
2. Do not adjust the variable resistor on the pickup unit. It was already adjusted.
3. Do not look at the focus lens using optical instruments.
4. Recommend not to look at pickup lens for a long time.

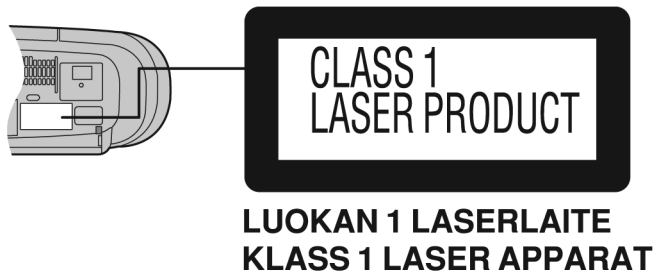

CAUTION	- CLASS 1M INVISIBLE LASER RADIATION WHEN OPEN. DO NOT VIEW DIRECTLY WITH OPTICAL INSTRUMENTS. (CD/DVD) - CLASS 1M
WARNING	- KLASSE 1M UNSEHBAR LASERSTRAHLUNG WENN DIE ABDECKUNG BETROFFEN. NICHT DIREKT MIT OPTISCHEN INSTRUMENTEN BETRACHTEN. (CD/DVD) - KLASSE 1M
FORSIGTIG	- LASERSTRÅLING KLASSE 1M. NÅR LASER ER ÅBENT UNNSÅR Å SE I ØYE MED OPTISKE INSTRUMENTER.
VARO!	- AVOITTESSÄ OLET ALTIINKI LUOKAN 1M NÄKYMÄTTÖNÄ LASERISÄTELYÄ ÄLLÄ KATSO OPTISELLA LAITTEELLA SUORAN SÄTEEN.
VORSICHT	- LASERSTRAHLUNG KLASSE 1M. WENN ABDECKUNG GEÖFFNET, NICHT DIREKT MIT OPTISCHEN INSTRUMENTEN BETRACHTEN.
ATTENTION	- RAYONNEMENT LASER INVISIBLE. CLASSE 1M EN CAS D'OUVERTURE. NE PAS REGARDER DIRECTEMENT À L'ŒIL S'INSTRUMENTS OPTIQUES.
PRECAUCIÓN	- RADIACIÓN LASER INVISIBLE DE CLASE 1M AL ESTAR ABIERTO. NO VEJA DIRECTAMENTE CON INSTRUMENTOS ÓPTICOS.
注意	- この装置から不可視レーザー光が出ます。 必ず目を遮り、望遠鏡などを用いては見てはいけません。
注意	- 此装置から不可視レーザー光が発射。望遠鏡などを用いては見てはいけません。

Inside of product

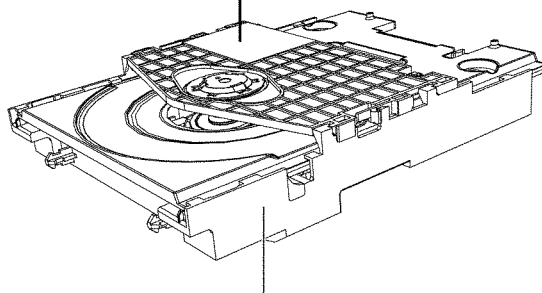

CD Mechanism Unit (DLS6F)

2.3. Service caution based on Legal restrictions

2.3.1. General description about Lead Free Solder (PbF)

The lead free solder has been used in the mounting process of all electrical components on the printed circuit boards used for this equipment in considering the globally environmental conservation.

The normal solder is the alloy of tin (Sn) and lead (Pb). On the other hand, the lead free solder is the alloy mainly consists of tin (Sn), silver (Ag) and Copper (Cu), and the melting point of the lead free solder is higher approx.30 degrees C (86°F) more than that of the normal solder.

Definition of PCB Lead Free Solder being used

The letter of "PbF" is printed either foil side or components side on the PCB using the lead free solder. (See right figure)	PbF
---	-----

Service caution for repair work using Lead Free Solder (PbF)

- The lead free solder has to be used when repairing the equipment for which the lead free solder is used.
(Definition: The letter of "PbF" is printed on the PCB using the lead free solder.)
- To put lead free solder, it should be well molten and mixed with the original lead free solder.
- Remove the remaining lead free solder on the PCB cleanly for soldering of the new IC.
- Since the melting point of the lead free solder is higher than that of the normal lead solder, it takes the longer time to melt the lead free solder.
- Use the soldering iron (more than 70W) equipped with the temperature control after setting the temperature at 350±30 degrees C (662±86°F).

Recommended Lead Free Solder (Service Parts Route.)

- The following 3 types of lead free solder are available through the service parts route.
RFKZ03D01K----- (0.3mm 100g Reel)
RFKZ06D01K----- (0.6mm 100g Reel)
RFKZ10D01K----- (1.0mm 100g Reel)

Note

- * Ingredient: Tin (Sn), 96.5%, Silver (Ag) 3.0%, Copper (Cu) 0.5%, Cobalt (Co) / Germanium (Ge) 0.1 to 0.3%

2.4. Handling Precaution for Traverse Unit

The laser diode in the optical pickup unit may break down due to static electricity of clothes or human body. Special care must be taken avoid caution to electrostatic breakdown when servicing and handling the laser diode in the traverse unit.

2.4.1. Cautions to Be Taken in Handling the Optical Pickup Unit

The laser diode in the optical pickup unit may be damaged due to electrostatic discharge generating from clothes or human body. Special care must be taken avoid caution to electrostatic discharge damage when servicing the laser diode.

1. Do not give a considerable shock to the optical pickup unit as it has an extremely high-precise structure.
2. To prevent the laser diode from the electrostatic discharge damage, the flexible cable of the optical pickup unit removed should be short-circuited with a short pin or a clip.
3. The flexible cable may be cut off if an excessive force is applied to it. Use caution when handling the flexible cable.
4. The antistatic FPC is connected to the new optical pickup unit. After replacing the optical pickup unit and connecting the flexible cable, cut off the antistatic FPC.

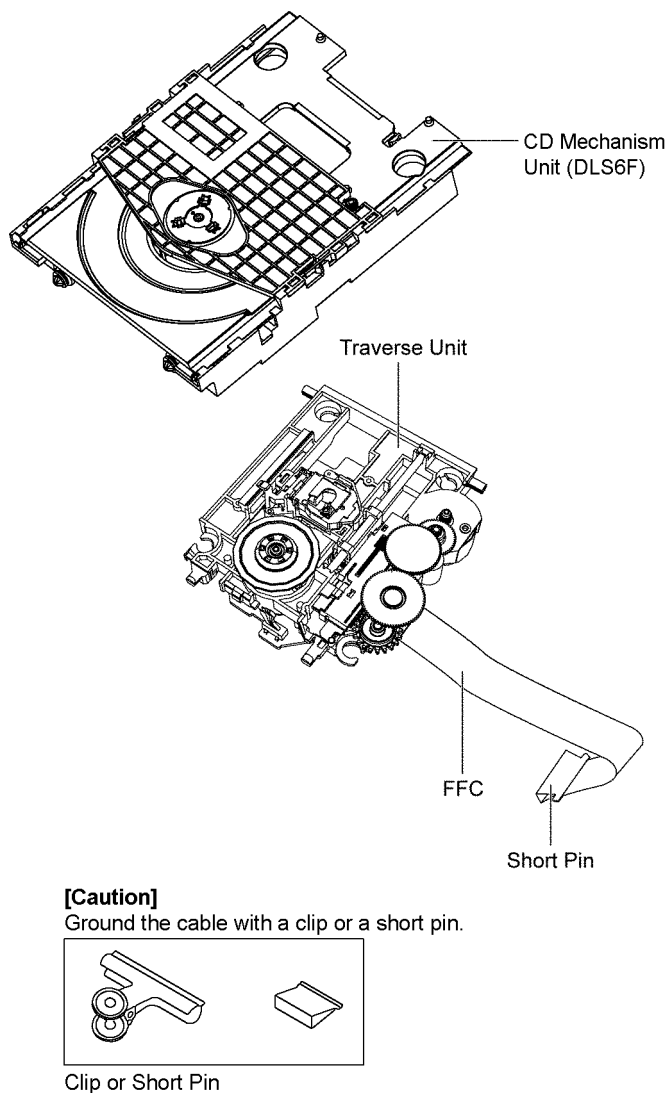

Figure 1

2.4.2. Grounding for electrostatic breakdown prevention

Some devices such as the CD player use the optical pickup (laser diode) and the optical pickup will be damaged by static electricity in the working environment. Proceed servicing works under the working environment where grounding works is completed.

2.4.2.1. Worktable grounding

1. Put a conductive material (sheet) or iron sheet on the area where the optical pickup is placed, and ground the sheet.

2.4.2.2. Human body grounding

1. Use the anti-static wrist strap to discharge the static electricity form your body (Figure 2).

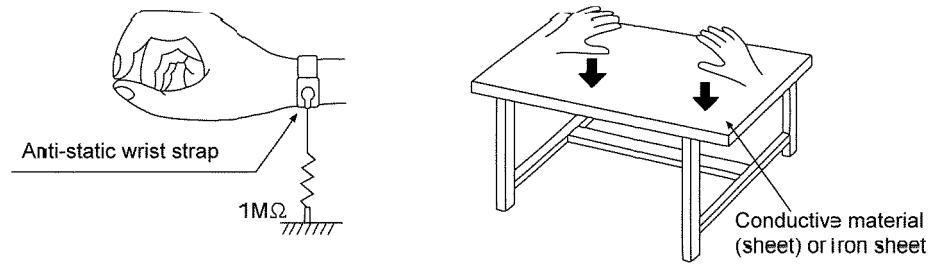

Figure 2

3 Service Navigation

3.1. Service Information

This service manual contains technical information which will allow service personnel's to understand and service this model. Please place orders using the parts list and not the drawing reference numbers.

If the circuit is changed or modified, this information will be followed by supplement service manual to be filed with original service manual.

- **CD Mechanism Unit (DLS6F):**

1) This model uses CD Mechanism Unit (DLS6F).

- **Micro-processor:**

1) The following components are supplied as an assembled part.

- Micro-processor IC, (IC2100) is supplied as assembled part (RFKWMD55EG).

3.2. Notes

This service manual contains technical information which will allow service personnel's to understand and service this model. Please place orders using the parts list and not the drawing reference numbers.

If the circuit is changed or modified, this information will be followed by supplement service manual to be filed with original service manual.

1) This service manual does not contains the following information

This simplified service manual is base on RX-D55EG-K. Please refer to the original service manual, RX-D55EG-K (Order No. PSG1004005CE) for the below mention contents.

- Location of Controls and Components
- Self Diagnostic and Doctor Mode Setting
- Service Fixture & Tools
- Disassembly and Assembly Instructions
- Disassembly and Assembly of Traverse Unit
- Service Position
- Measurements and Adjustments
- Voltage Measurement & Waveform Chart
- Wiring Connection Diagram
- Schematic Diagram Notes
- Terminal Function of IC's

2) This service manual contains include the following information

- Safety Precautions
- Warning
- Service Navigation
- Specifications
- Illustration of IC's, Transistors and Diodes
- Schematic Diagram (MAIN & POWER CIRCUIT)
- Printed Circuit Board (MAIN, DECK, POWER, BATTERY (1), BATTERY (2) & MUSIC PORT P.C.B.)
- Exploded View and Replacement Parts List

3.3. Different Points

Ref. No.	Parts No.		Parts name & Description	Remarks
	RX-D55EG-K	RX-D55EE-K		
26	RYQN0009H-S	RYQN0009L-S	BOTTOM CABINET ASS'Y	
P1	RPGX3060	RPGX3061	PACKING CASE	
A3	RQTX1034-D	RQTX1037-R	O/I BOOK (Ru/Ur)	
A3	RQTX1035-E	-	O/I BOOK (Du/Da/Sw)	
A3	RQTX1041-Z	-	O/I BOOK (En/Sp/Po/Cz)	
PCB1	REPNT0065AA	REPNT0065BA	MAIN P.C.B	(RTL)
PCB3	REPNT0063G	REPNT0063H	POWER P.C.B	(RTL)
PCB6	REPNT0065AB	REPNT0065BB	DECK P.C.B	(RTL)
PCB9	REPNT0063G	REPNT0063H	BATTERY (1) P.C.B	(RTL)
PCB10	REPNT0063G	REPNT0063H	BATTERY (2) P.C.B	(RTL)
PCB11	REPNT0065AC	REPNT0065BC	MUSIC PORT P.C.B	(RTL)
IC4100	C0CBABC00115	C0CBABE00040	IC	
IC5901	C0DBEKG00003	-	IC	
Q5904	B1GBCFJN0033	-	TRANSISTOR	
Q5905	B1ABCF000176	-	TRANSISTOR	
D5914	B0JACE000003	-	DIODE	
D5919	B0JACE000003	-	DIODE	
D5920	B0ACCK000005	-	DIODE	
D5921	B0EAKM000117	-	DIODE	
D5922	B0EAKM000117	-	DIODE	
D5923	B0EAKM000117	-	DIODE	
D5924	B0EAKM000117	-	DIODE	
D5927	-	B0ACCK000005	DIODE	
D5928	-	B0EAKM000117	DIODE	
D5929	-	B0EAKM000117	DIODE	
D5930	-	B0EAKM000117	DIODE	
D5931	-	B0EAKM000117	DIODE	
T5904	G4C2AAH00002	-	SUB TRANSFORMER	
RL5901	K6B1AEA00003	-	RELAY	
R2115	ERJ3GEYF184V	ERJ3GEYF224V	220K 1/10W	
R5900	ERJ3GEYJ153V	-	15K 1/10W	
R5901	ERJ3GEYJ334V	-	330K 1/10W	
R5907	ERJ3GEYJ103V	-	10K 1/10W	
R5910	-	ERJ3GEYJ473V	47K 1/10W	
R5912	ERJ3GEYJ473V	-	47K 1/10W	
R5913	ERJ3GEYJ824V	-	820K 1/10W	POWER
R5914	ERJ3GEYJ683V	-	68K 1/10W	POWER
R5915	ERJ3GEYJ824V	-	820K 1/10W	POWER
R5917	-	ERJ3GEYJ103V	10K 1/10W	POWER
R5938	ERJ3GEYF184V	ERJ3GEYF154V	150K 1/10W	
C4111	F2A1C471A030	F2A1E471A121	470uF 25V	
C5905	F1H1H103A219	-	0.01uF 50V	
C5906	F1H1H103A219	-	0.01uF 50V	
C5907	F1H1H103A219	-	0.01uF 50V	
C5908	F1H1H103A219	ERJ3GEY0R00V	0 1/10W	
C5916	F1H1H104A913	-	0.1uF 50V	
C5917	F2A1C220A019	-	22uF 16V	
C5918	F2A1A2210012	-	220uF 10V	
C5919	F1H1H104A913	-	0.1uF 50V	
C5920	F1H1H104A913	-	0.1uF 50V	
C5921	F1H1H104A913	-	0.1uF 50V	
C5923	F1H1H104A913	-	0.1uF 50V	
C5999	F2A1E220A122	-	22uF 25V	

4 Specifications

■ Amplifier Section

Output power 10 W x 2 (RMS MAX / DC)
PMPO output power 280 W

■ FM/AM Tuner, Terminal Section

Frequency Modulation (FM)
Frequency range 87.50 MHz to 108.00 MHz (50 kHz step)

Amplitude Modulation (AM)

Frequency range 522 kHz to 1629 kHz (9 kHz step)
520 kHz to 1630 kHz (10 kHz step)

Headphone jack

Terminal Stereo, 3.5 mm jack (32 Ω)

Music port (front) jack

Sensitivity 100 mV, 4.7 kΩ
Terminal Stereo, 3.5 mm jack

■ Disc Section

Disc played (8 cm or 12 cm)

- (1) CD-Audio (CD-DA)
- (2) CD-R/RW (CD-DA, MP3* formatted disc)
- (3) MP3*

* MPEG-1 Layer 3, MPEG-2 Layer 3

Bit rate

MP3 32 kbps to 320 kbps

Sampling frequency

CD 44.1 kHz

MP3 32 kHz, 44.1 kHz, 48 kHz

Decoding 16 bit linear

Beam source Semiconductor laser (wavelength 795 nm (CD))

Frequency response 40 Hz to 20kHz

Number of channels 2 channel, stereo

Wow and flutter Less than possible measurement data

■ Cassette Deck Section

Track system 4 track, 2 channel, stereo

Monitor system Variable sound monitor

Recording system AC bias 84 kHz

Erase system Multi pole magnet

Overall frequency response
NORMAL 50 Hz to 12 kHz

■ USB Section

USB port

Media file format support MP3 (*.mp3)

USB device file system FAT 12, FAT 16, FAT 32

USB port power 500 mA (Max)

■ Speaker Section

Speakers Impedance 4 Ω

Full range 2 x 8 cm

Ceramic tweeter 2 x 1.5 cm

■ General

Power supply

AC 230 V, 50 Hz

Battery 12 V (8 x LR14, C)

Memory back-up 6 V (4 x R6/LR6, AA)

Power consumption 27 W

Battery life (use only alkaline batteries)

Radio broadcast 3.2 hours

Radio recording 7 hours

CD playback 2.4 hours

CD recording 5 hours

Tape playback 2.5 hours

Dimensions (W x H x D) 408 mm x 148 mm x 271 mm

Mass 4 kg without batteries (4.6 kg with batteries)

Operating temperature range 0°C to +40°C

Operating humidity range 35% to 80 % RH (no condensation)

Power consumption in standby mode: 2.6 W (approximate)

Notes :

1. Specifications are subject to change without notices.

Mass and dimensions are approximate.

2. Total harmonic distortion is measured by the digital spectrum analyzer.

5 Illustration of IC's, Transistors and Diodes

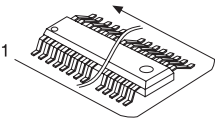
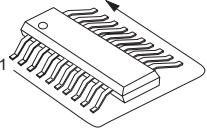
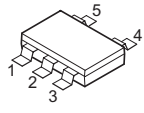
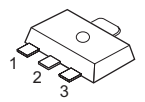
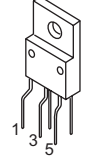
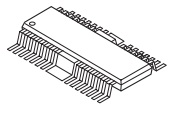
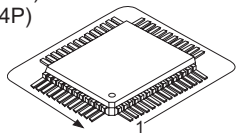
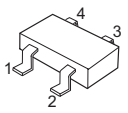
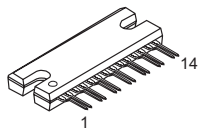
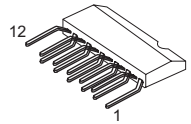
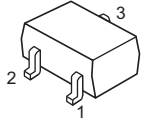
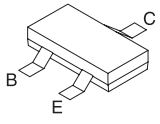
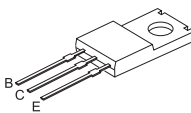
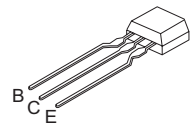
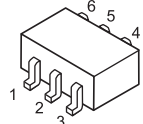
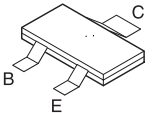
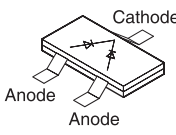
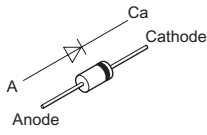
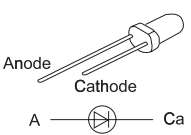
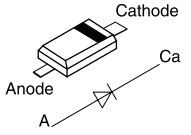
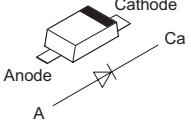
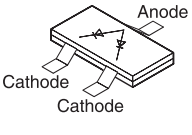
<p>BA5948FPE2 (28P) C1BB00000732 (32P)</p> 	<p>C1BB00001120 (36P)</p> 	<p>C0CBABE00023</p> 	<p>C0CBABE00040</p> 	<p>C0DAEJG00001</p> 	<p>C3ABMB000050 (26P)</p> 
<p>MN6627954AMA (100P) C0HBA0000268 (44P) RFKWMD55EG (100P) MNZSFB5KJM2 (64P)</p> 	<p>C0EBE0000124</p> 	<p>C1BA00000420</p> 	<p>BA3313L</p> 	<p>B1GDCFNN0007</p> 	
<p>B1ABCF000176 B1ADCE000012 B1GBCFJN0033 B1ABDF000026</p> 	<p>B1BCCG000002</p> 	<p>B1ACCF000094</p> 	<p>B1HBECA00004</p> 	<p>B1ADCF000001</p> 	
<p>B0CDAB000019 B0CDAD000010</p> 	<p>B0EAKM000117 B0EAMM000038</p> 	<p>B3ACA0000264</p> 	<p>MAZ8056GML</p> 	<p>B0ACCK000005 B0BC9R1A0218</p> 	<p>B0ADFJ000004</p> 

6 Schematic Diagram

6.1. MAIN CIRCUIT (1/6)

SCHEMATIC DIAGRAM - 2

B MAIN CIRCUIT

— : +B SIGNAL LINE
 : CD/TAPE AUDIO INPUT SIGNAL LINE
 : MUSIC PORT AUDIO INPUT SIGNAL LINE
 : AUDIO OUTPUT SIGNAL LINE
 : FM SIGNAL LINE
 : AM SIGNAL LINE
 : FM/AM SIGNAL LINE

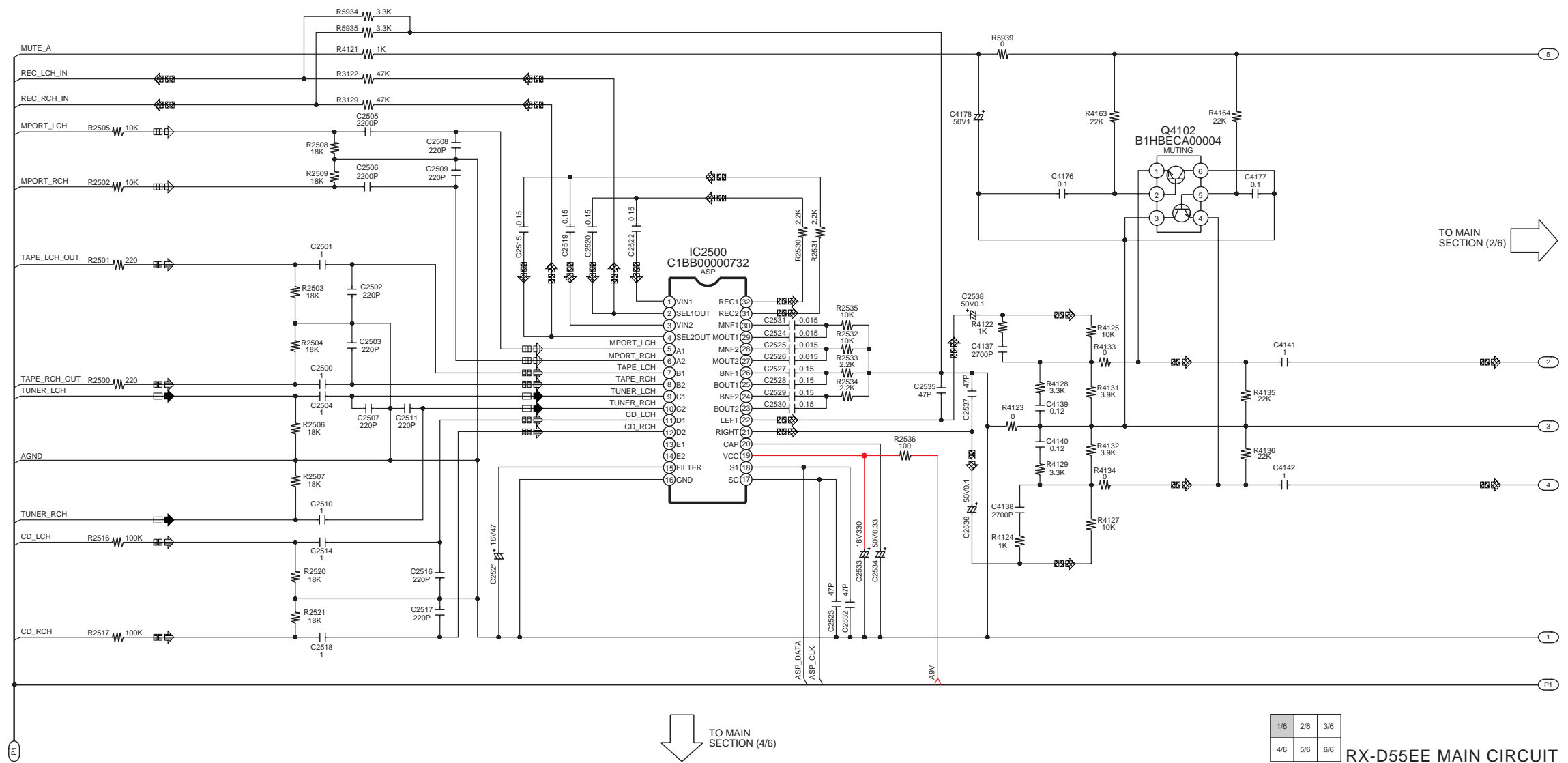

TO MAIN SECTION (4/6)

TO MAIN SECTION (2/6)

1/6	2/6	3/6
4/6	5/6	6/6

RX-D55EE MAIN CIRCUIT

6.2. MAIN CIRCUIT (2/6)

SCHEMATIC DIAGRAM - 3

B MAIN CIRCUIT

— : +B SIGNAL LINE
 : CD/TAPE AUDIO INPUT SIGNAL LINE
 : MUSIC PORT AUDIO INPUT SIGNAL LINE
 : AUDIO OUTPUT SIGNAL LINE
 : FM SIGNAL LINE
 : AM SIGNAL LINE
 : FM/AM SIGNAL LINE

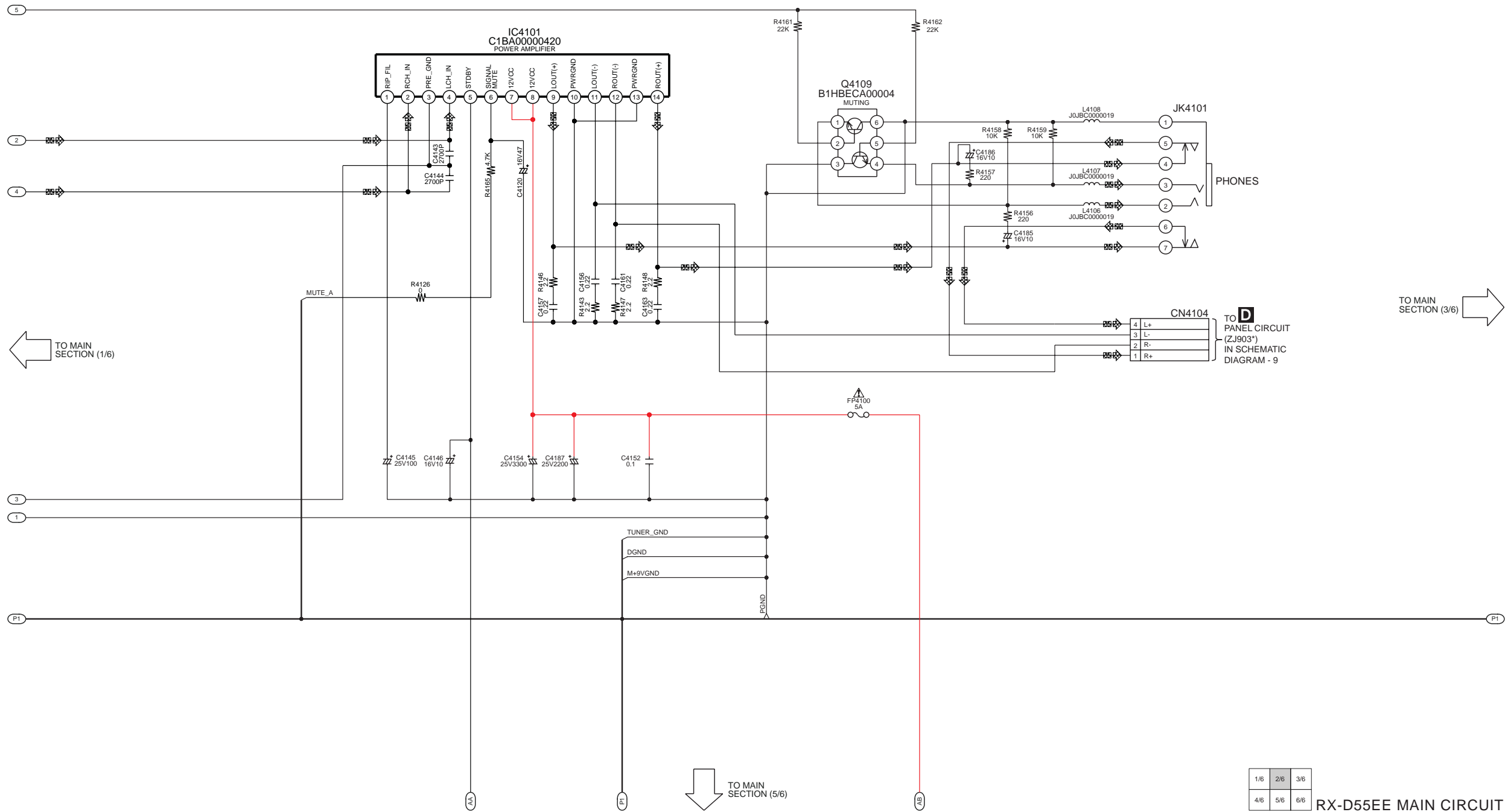

6.3. MAIN CIRCUIT (3/6)

SCHEMATIC DIAGRAM - 4

B MAIN CIRCUIT

— : +B SIGNAL LINE
 : CD/TAPE AUDIO INPUT SIGNAL LINE
 : MUSIC PORT AUDIO INPUT SIGNAL LINE
 : AUDIO OUTPUT SIGNAL LINE
 : FM SIGNAL LINE
 : AM SIGNAL LINE
 : FM/AM SIGNAL LINE

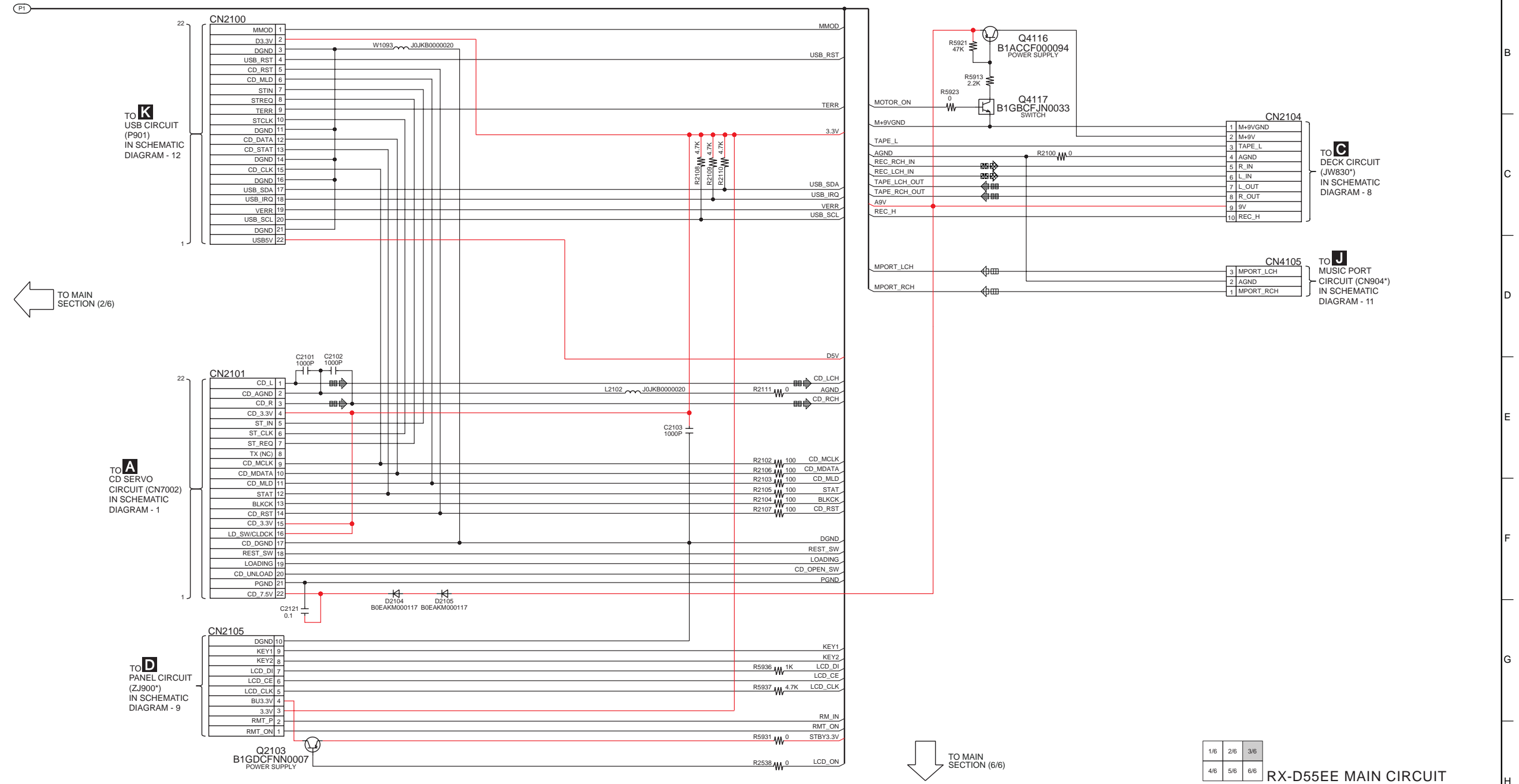

6.4. MAIN CIRCUIT (4/6)

SCHEMATIC DIAGRAM - 5

B MAIN CIRCUIT

— : +B SIGNAL LINE
 : CD/TAPE AUDIO INPUT SIGNAL LINE
 : MUSIC PORT AUDIO INPUT SIGNAL LINE
 : AUDIO OUTPUT SIGNAL LINE
 : FM SIGNAL LINE
 : AM SIGNAL LINE
 : FM/AM SIGNAL LINE

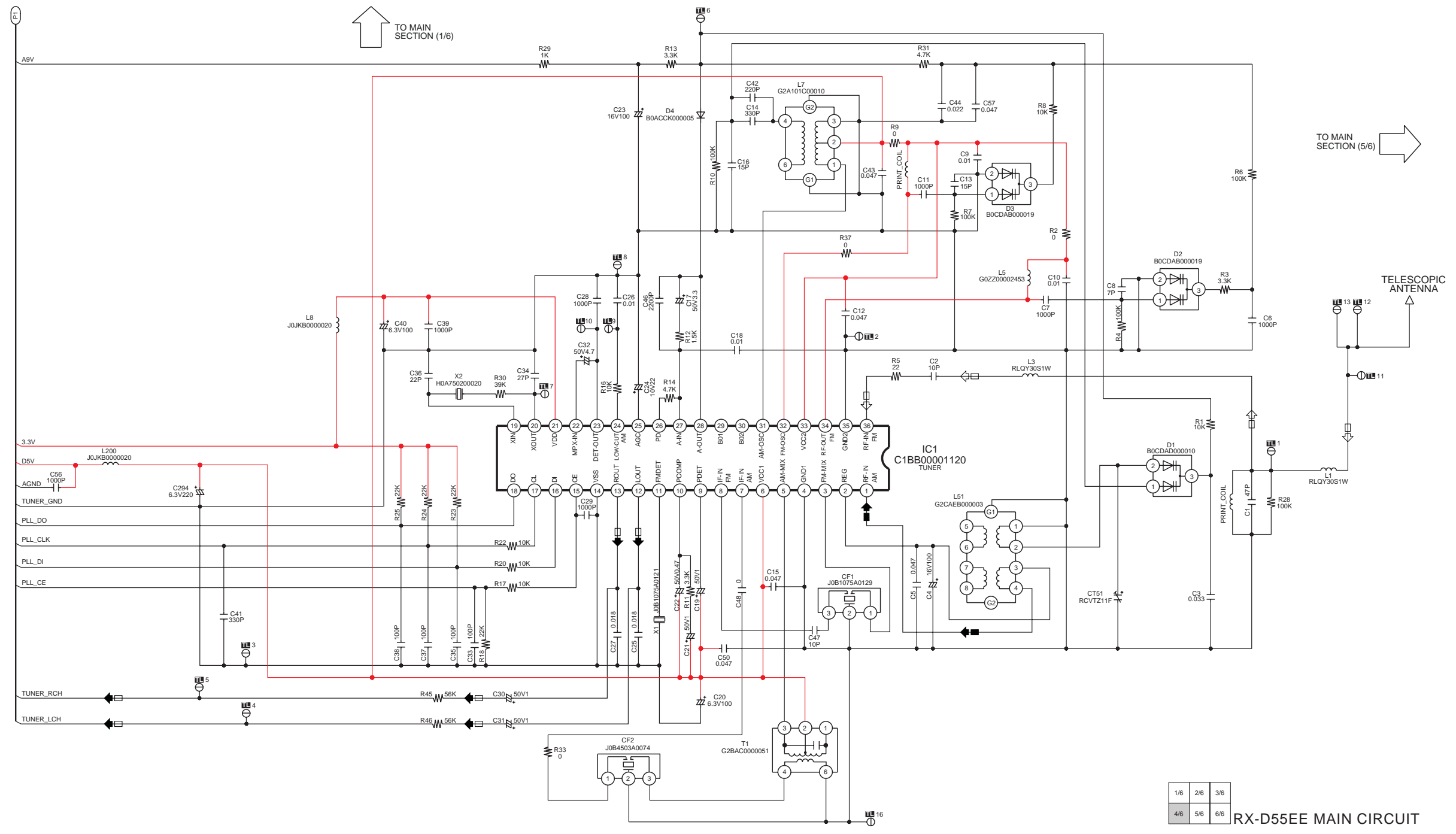

1/6	2/6	3/6
4/6	5/6	6/6

RX-D55EE MAIN CIRCUIT

6.5. MAIN CIRCUIT (5/6)

SCHEMATIC DIAGRAM - 6 B MAIN CIRCUIT

— : +B SIGNAL LINE
 : CD/TAPE AUDIO INPUT SIGNAL LINE
 : MUSIC PORT AUDIO INPUT SIGNAL LINE
 : AUDIO OUTPUT SIGNAL LINE
 : FM SIGNAL LINE
 : AM SIGNAL LINE
 : FM/AM SIGNAL LINE

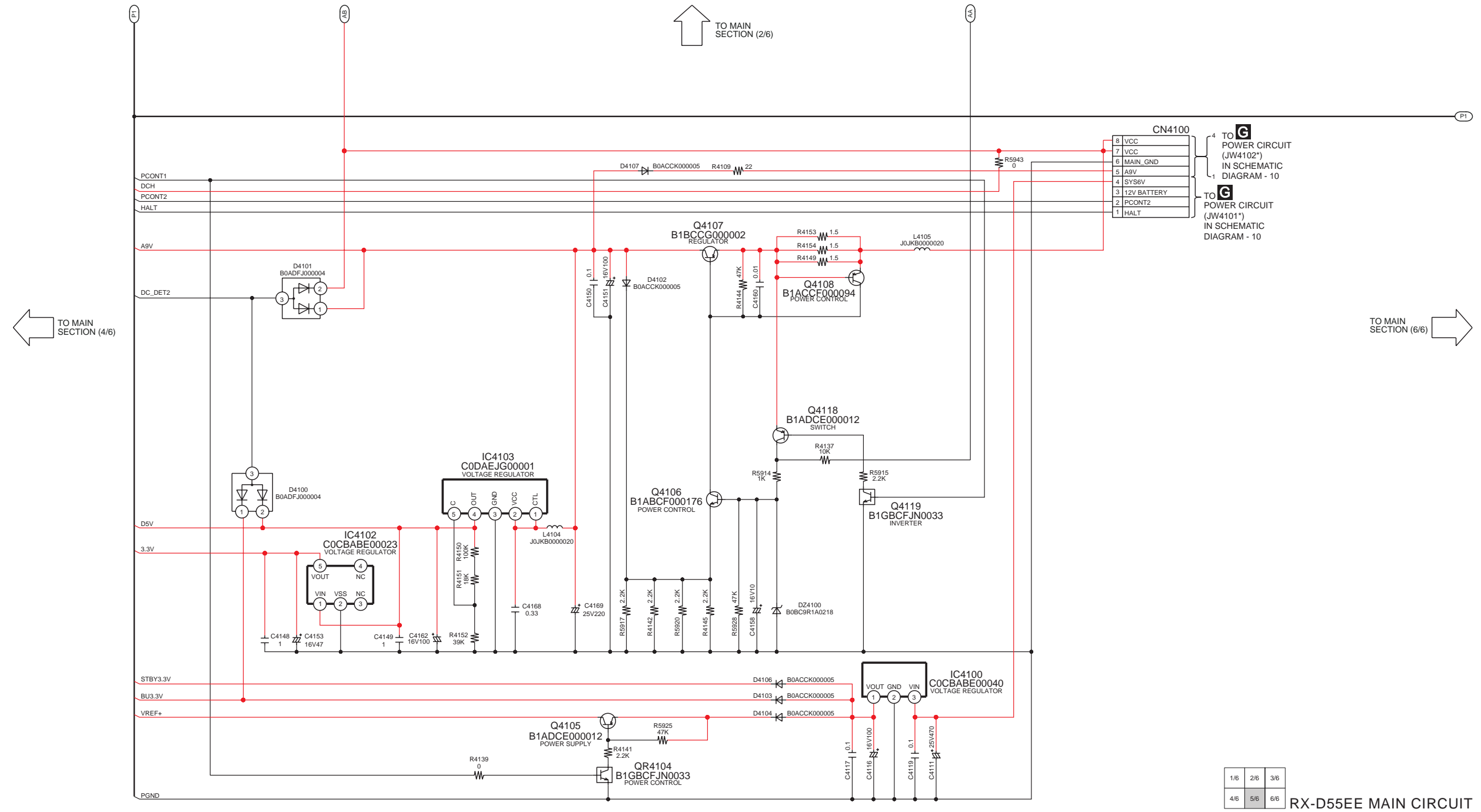

1/6	2/6	3/6
4/6	5/6	6/6

 RX-D55EE MAIN CIRCUIT

15 16 17 18 19 20 21 22 23 24 25 26 27 28

6.6. MAIN CIRCUIT (6/6)

SCHEMATIC DIAGRAM - 7

B MAIN CIRCUIT

— : +B SIGNAL LINE
 : CD/TAPE AUDIO INPUT SIGNAL LINE
 : MUSIC PORT AUDIO INPUT SIGNAL LINE
 : AUDIO OUTPUT SIGNAL LINE
 : FM SIGNAL LINE
 : AM SIGNAL LINE
 : FM/AM SIGNAL LINE

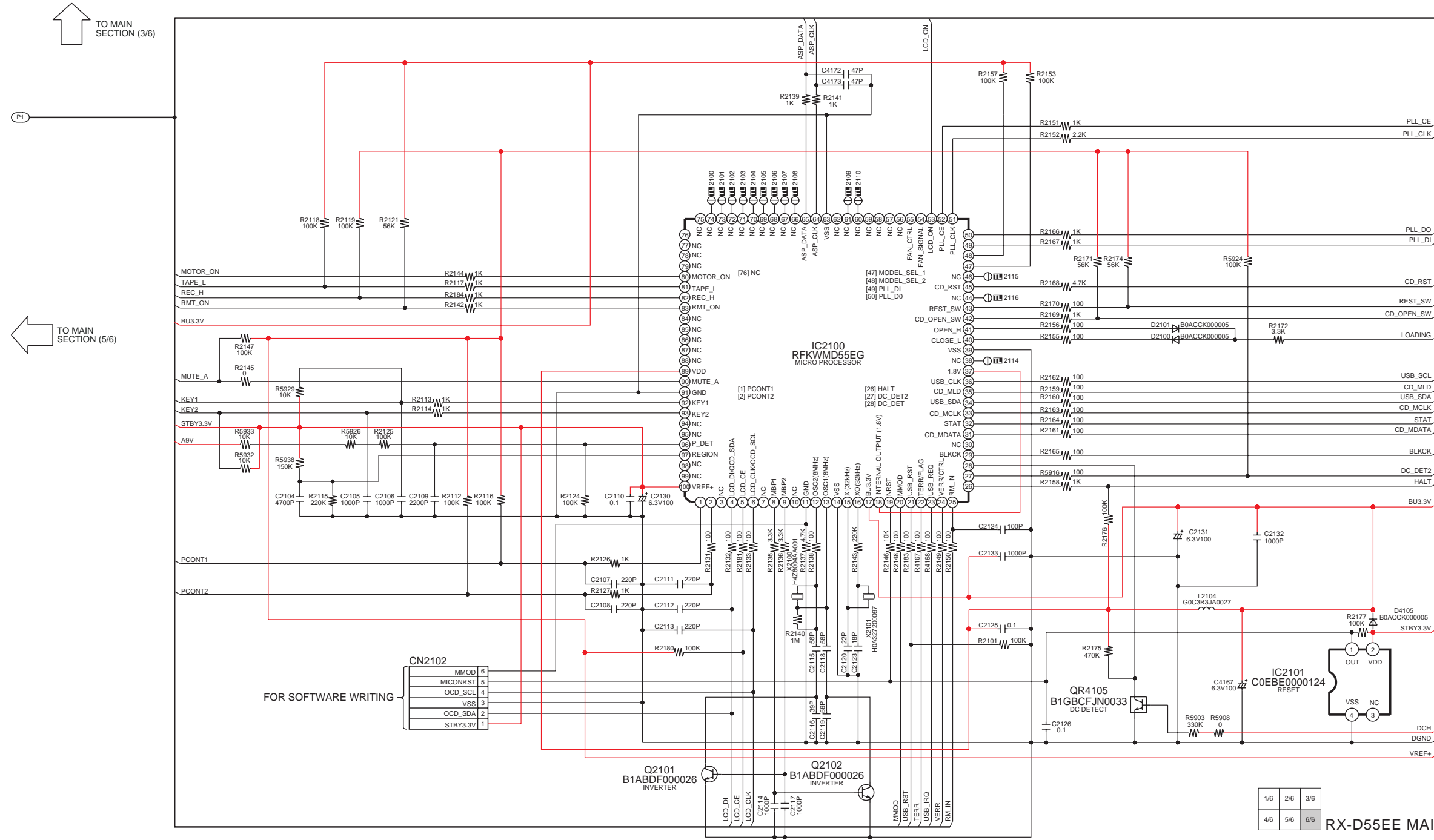

1/6	2/6	3/6
4/6	5/6	6/6

RX-D55EE MAIN CIRCUIT

6.7. POWER CIRCUIT

SCHMATIC DIAGRAM - 10
G POWER CIRCUIT

— : +B SIGNAL LINE

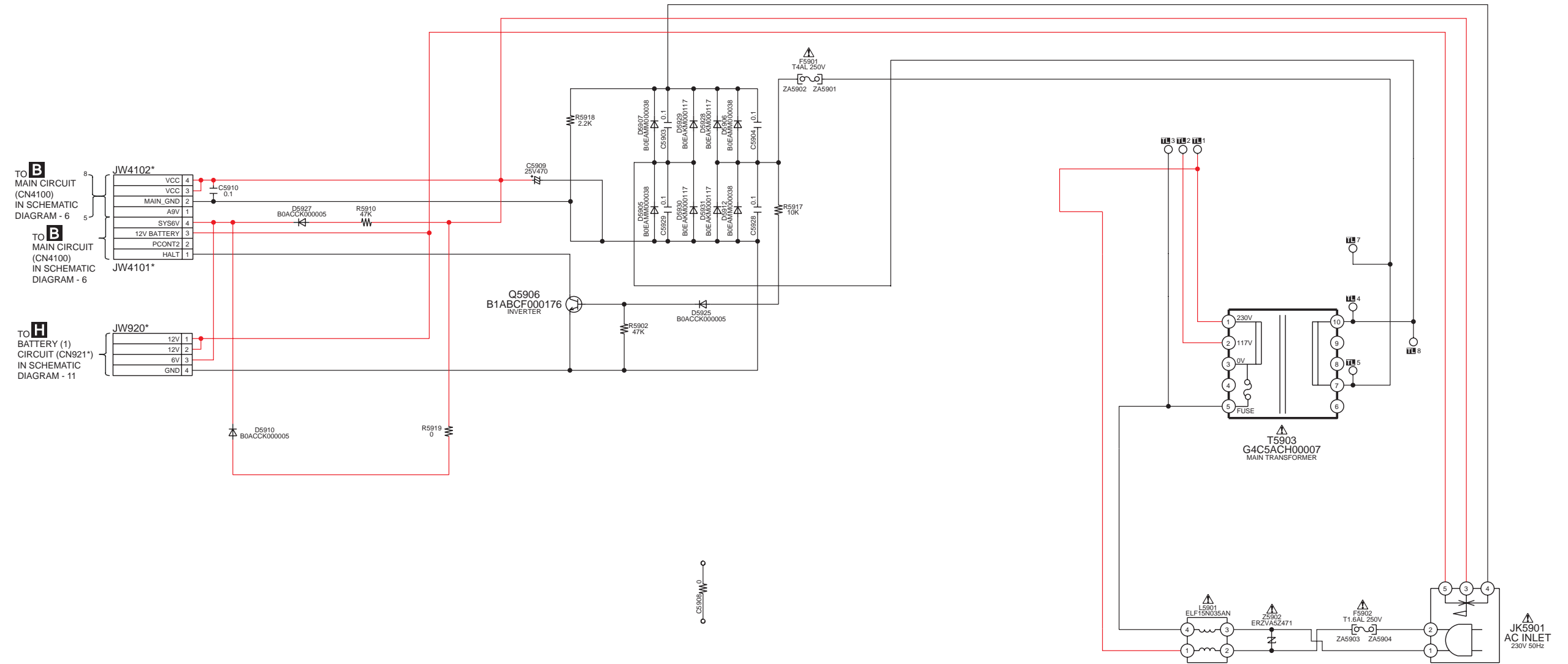

RX-D55EE POWER CIRCUIT

7 Printed Circuit Board

7.1. MAIN P.C.B.

B MAIN P.C.B. (REPNT0065BA)

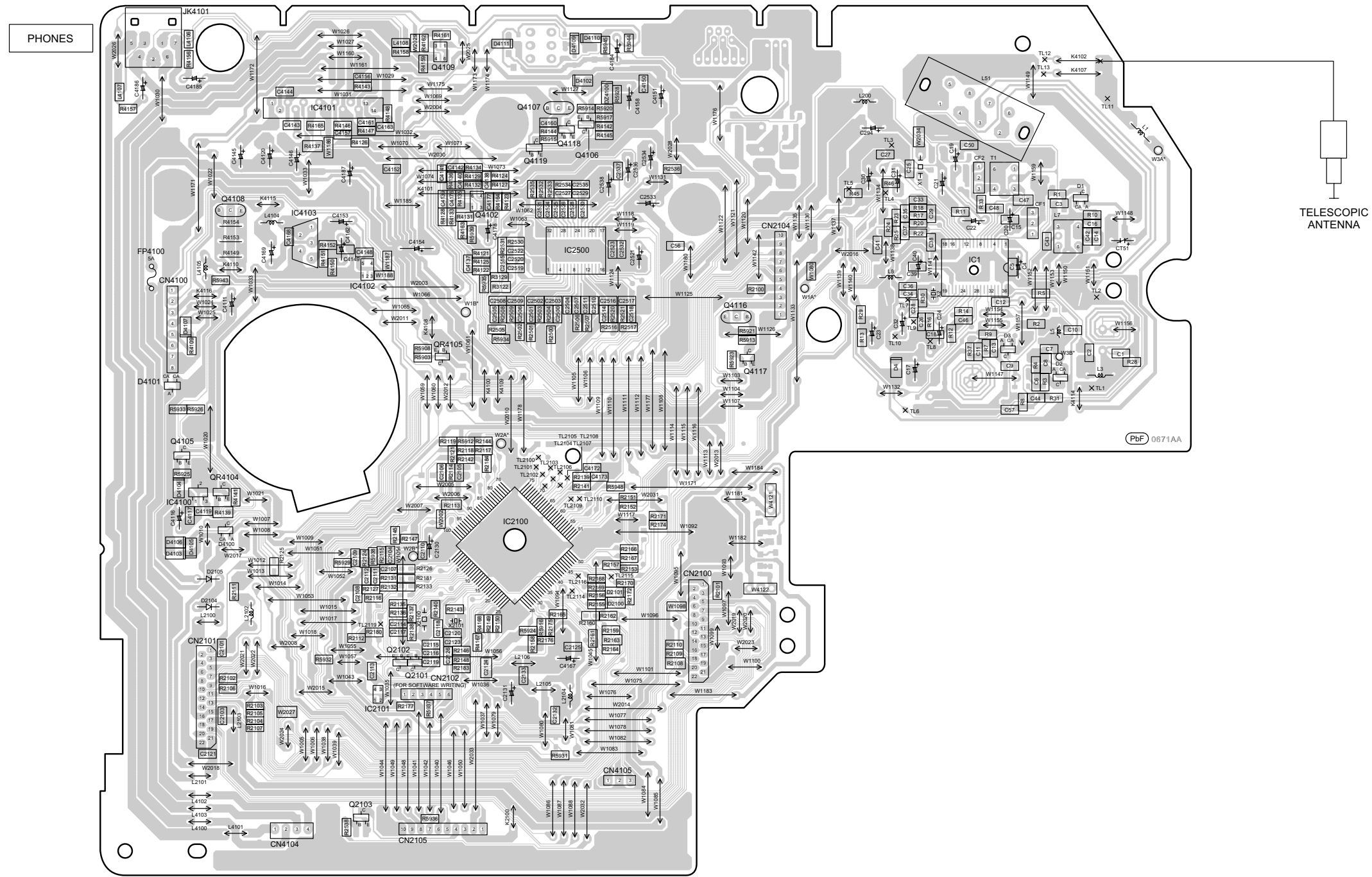

NOTE: " " REF IS FOR INDICATION ONLY.

RX-D55EE
MAIN P.C.B.

7.3. POWER, BATTERY (1), BATTERY (2) & MUSIC PORT P.C.B.

G POWER P.C.B. (REPNT0063H)

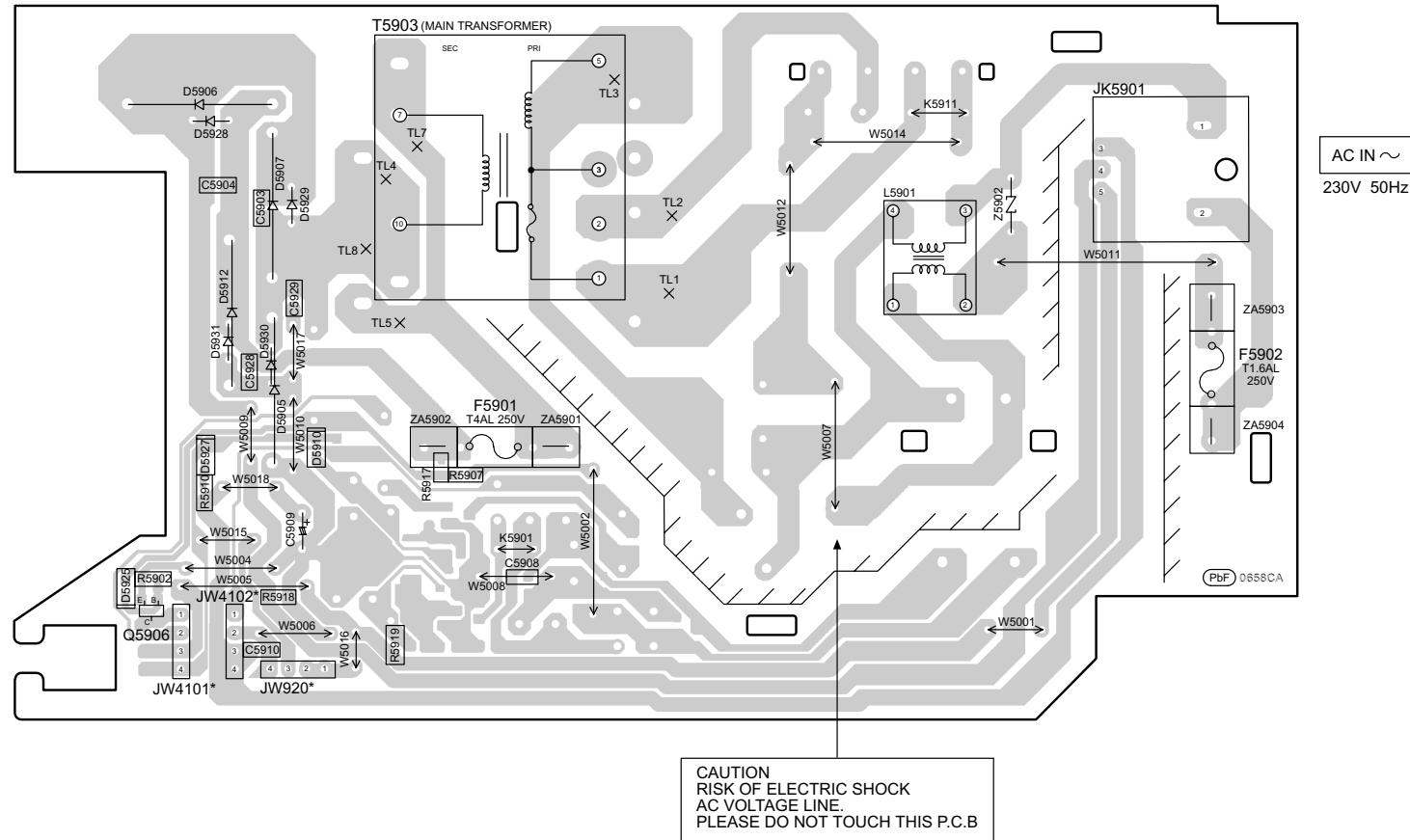

H BATTERY (1) P.C.B. (REPNT0063H)

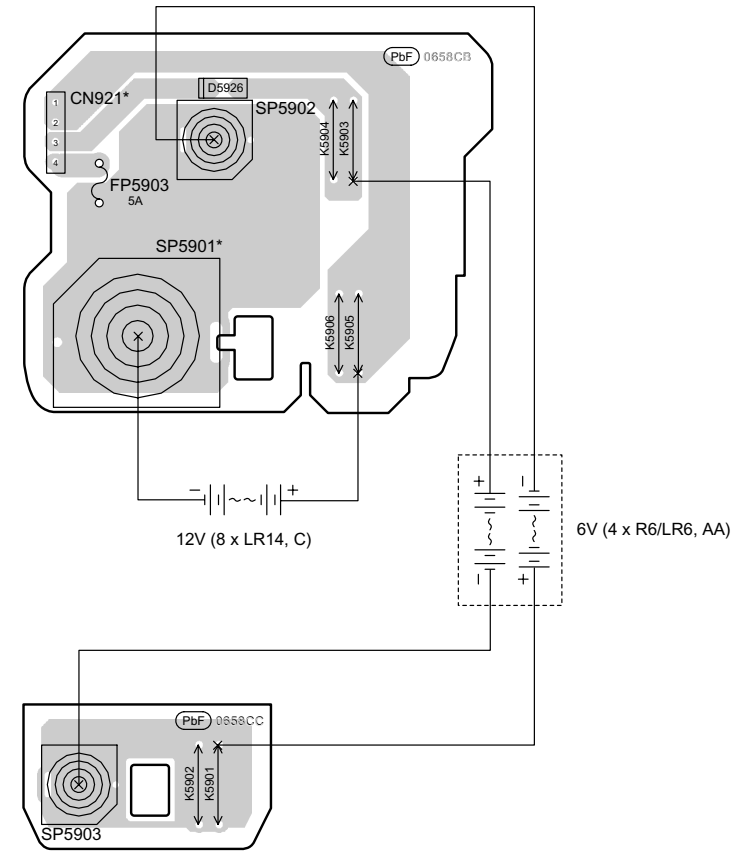

J MUSIC PORT P.C.B. (REPNT0065BC)

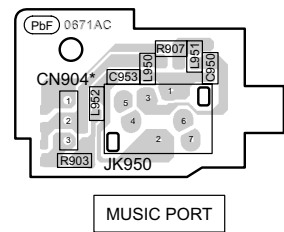

NOTE: "*" REF IS FOR INDICATION ONLY.

I BATTERY (2) P.C.B. (REPNT0063H)

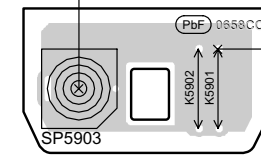

RX-D55EE
POWER / BATTERY (1) / BATTERY (2) / MUSIC PORT P.C.B.

8 Exploded View and Replacement Parts List

8.1. Exploded View and Mechanical replacement Parts List

8.1.1. Cabinet Parts Location

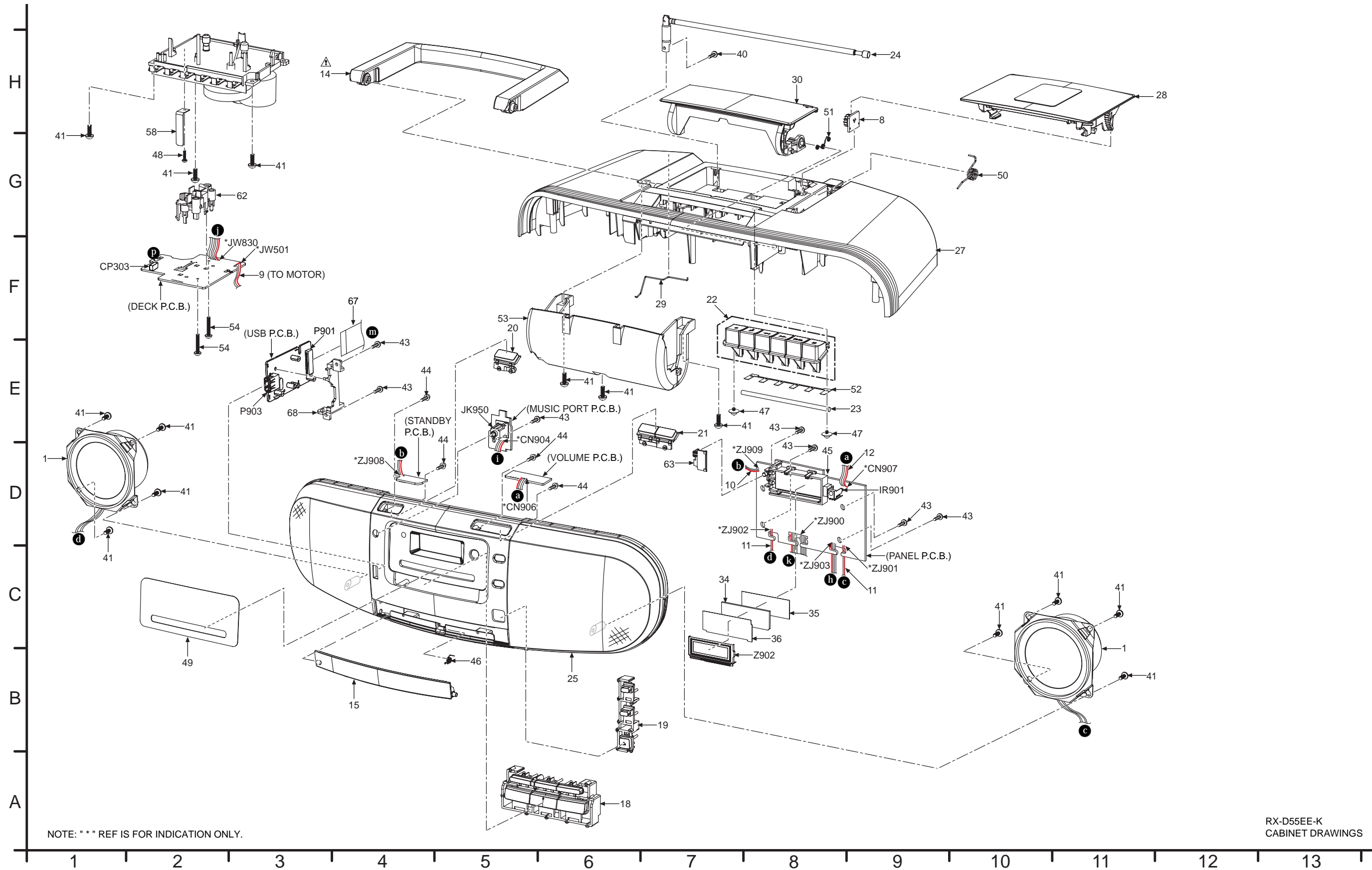

H
G
F
E
D
C
B
A

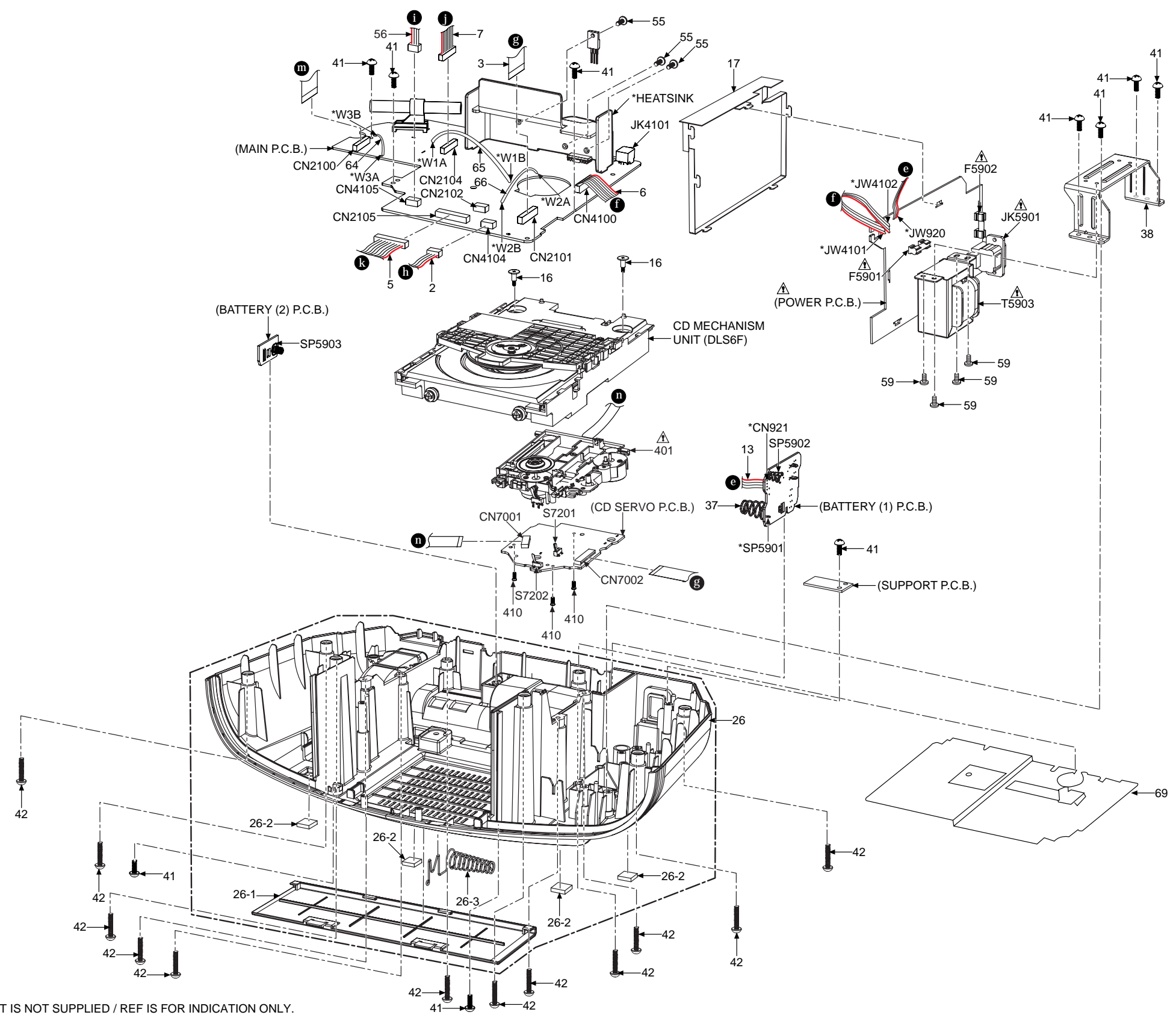

NOTE: "*" PART IS NOT SUPPLIED / REF IS FOR INDICATION ONLY.

RX-D55EE-K
CABINET DRAWINGS

1 2 3 4 5 6 7 8 9 10 11 12 13

8.1.2. Deck Mechanism Parts Location (RAA0948-N)

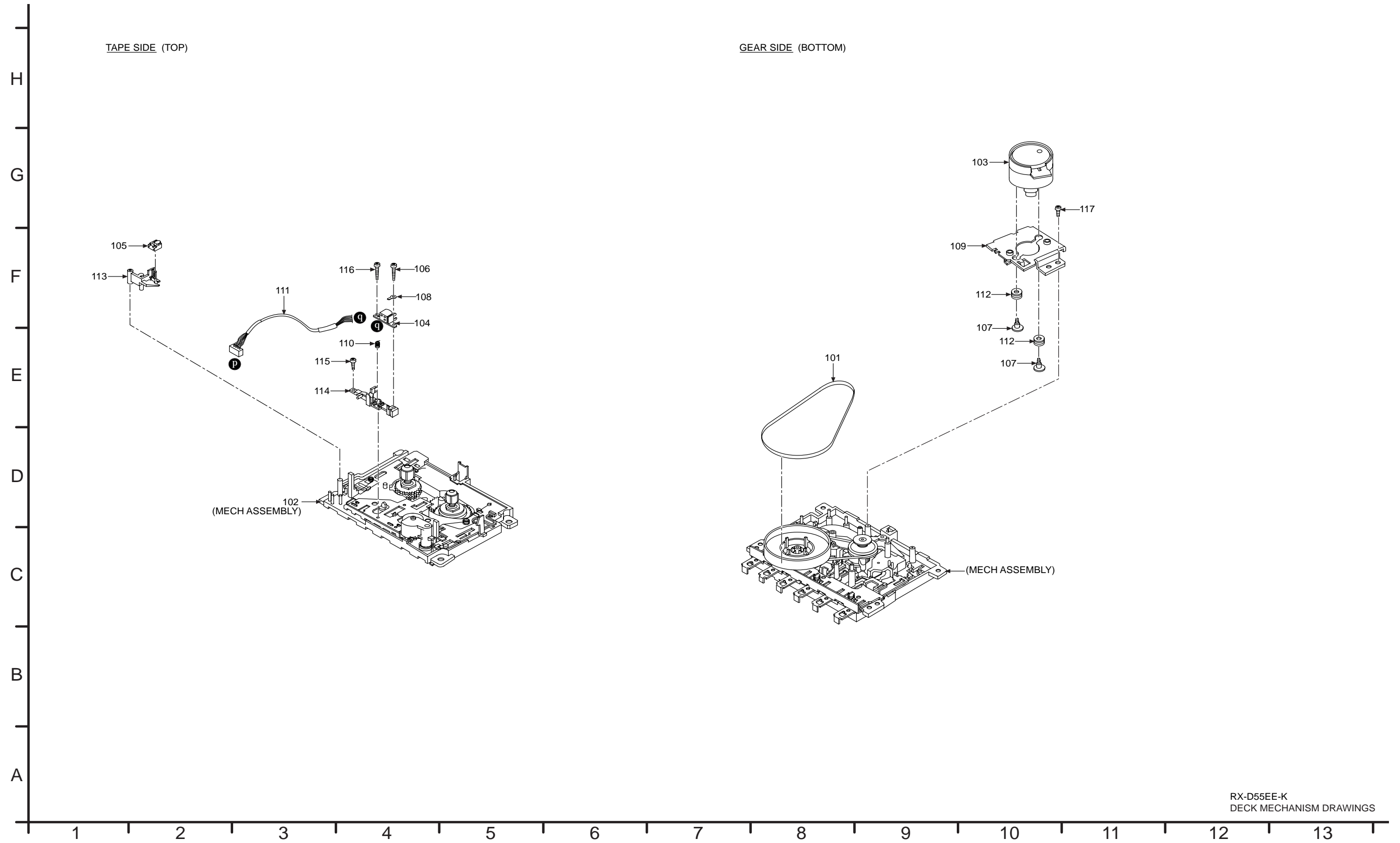

RX-D55EE-K
DECK MECHANISM DRAWINGS

8.1.3. Packaging

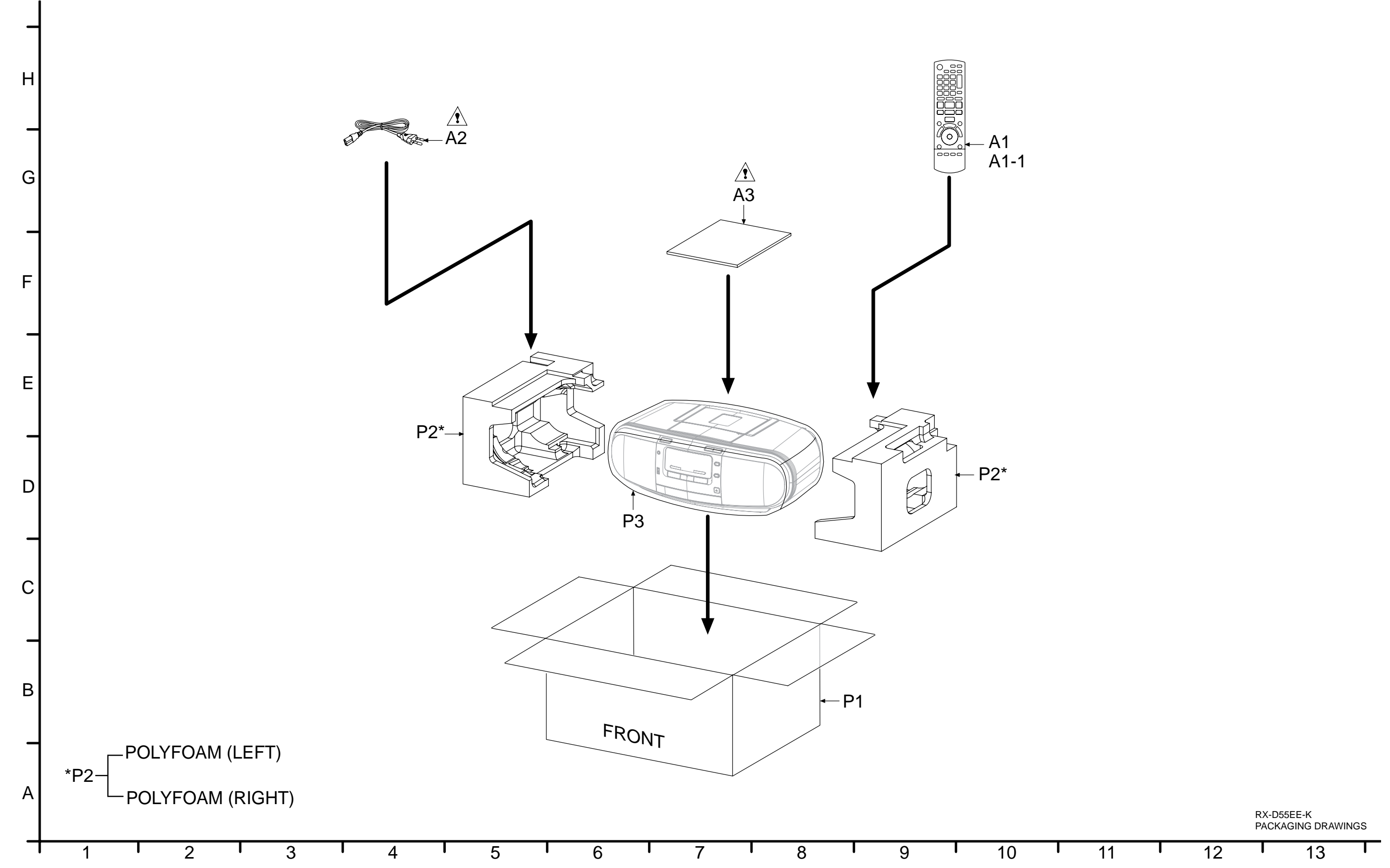

RX-D55EE-K
PACKAGING DRAWINGS

8.1.4. Mechanical Repacement Parts List

Important Safety Notice

Components identified by  mark have special characteristics important for safety. When replacing any of these components, use only manufacturer's specified parts.

RTL (Retention Time Limited)

Note: The marking (RTL) indicates that the Retention Time is Limited for this item.

After the discontinuation of this assembly in production, the item will continue to be available for a specific period of time. The retention period of availability is dependant on the type of assembly, and in accordance with the laws governing part and product retention. After the end of this period, the assembly will no longer be available.

Note:

- When replacing any of these components, be sure to use only manufacturer's specified parts shown in the replacement part list.
- The parenthesized indications on the Remarks column specify the destination & product color (Refer to the cover page for the information).
- Parts without these indications shall be used for all areas.
- This product uses a laser diode. Refer to "Precaution of Laser Diode".
- All parts mentioned are supplied by PAVCSG unless indicated likewise.
- Parts mentioned [SPG] in the Remarks column are supplied by PAVC-CSG.
- Reference for O/I book languages are as follows:

Ar:	Arabic	Du:	Dutch	It:	Italian	Sp:	Spanish
Cf:	Canadian French	En:	English	Ko:	Korean	Sw:	Swedish
Cz:	Czech	Fr:	French	Po:	Polish	Co:	Traditional Chinese
Da:	Danish	Ge:	German	Ru:	Russian	Cn:	Simplified Chinese
Pe:	Persian	Ur:	Ukraine	Pr:	Portuguese		

Safety	Ref. No.	Part No.	Part Name & Description	QTY	Remarks
			CABINET AND CHASSIS		
	1	RASN8P055-G	SPEAKER	2	
	2	REXN0082-1	4P CABLE WIRE (MAIN-PANEL)	1	
	3	REEN0027	22P FFC (MAIN-CD)	1	
	5	REXN0080	10P CABLE WIRE (MAIN-PANEL)	1	
	6	REXN0081-1	8P CABLE WIRE (MAIN-POWER)	1	
	7	REXN0084	10P CABLE WIRE (MAIN-DECK)	1	
	8	RXGX0002	DAMPER GEAR	1	
	9	RWJ0302060KD	2P WIRE (DECK-MOTOR)	1	
	10	RWJ0202095KK	2P CABLE WIRE (PANEL-STANDBY)	1	
	11	RWJ0202155KK	2P CABEL WIRE (PANEL-SPEAKER UNIT)	2	
	12	RWJ0203096KK	3P CABLE WIRE (PANEL-VOLUME)	1	
	13	RWJ0204222KK	4P CABLE WIRE (BATT (1) - POWER)	1	
	14	RKHN0005B-H	HANDLE	1	
	15	RKFN0020-K	CD LID	1	
	16	RHDX03001	SCREW	2	
	17	RMVN0066	SAFETY COVER	1	
	18	RGUN0055-K	MAIN BUTTON	1	
	19	RGUN0056-K	SOUND EQ BUTTON	1	
	20	RGUN0058-K	POWER BUTTON	1	

Safety	Ref. No.	Part No.	Part Name & Description	QTY	Remarks
	21	RGUN0059-K	VOLUME BUTTON	1	
	22	RGZN0008B-H	MECHA BUTTON	1	
	23	SUX102A-1	MECHA BUTTON HOLDING	1	
	24	XEARR210CA-C	ROD ANTENNA	1	
	25	RFKGD55EG-K	FRONT CABINET ASS'Y	1	
	26	RYQN0009L-S	BOTTOM CABINET ASS'Y	1	
	26-1	RKKN0007B-S	BATTERY COVER	1	
	26-2	RMGX0022	RUBBER LEG	4	
	26-3	RJCN0010-1	BATTERY TERMINAL	1	
	27	RYQN0008B-S	TOP CABINET ASS'Y	1	
	28	RFKLD55EG-K	CASSETTE LID ASS'Y	1	
	29	RJRN0017	ANTENNA TERMINAL	1	
	30	RKFN0019B-S	MECHA BOTTOM COVER	1	
	34	RGLN0009	LIGHTING PIECE	1	
	35	RGLN0010	DIFFUSER SHEET	1	
	36	RGLN0011	REFLECTOR SHEET	1	
	37	RJCN0011-1	BATTERY SPRING	1	
	38	RMAN0051	TRANSFORMER BRACKET	1	
	40	XYN3+F12FJ	SCREW	1	
	41	XTV3+10GFJ	SCREW	24	
	42	XTV3+16GFJ	SCREW	12	
	43	XTB26+10GFJ	SCREW	7	
	44	XTW26+10SFJ	SCREW	4	
	45	RMKN0012-W	LCD HOLDER	1	
	46	RMEN0009	CD LID SPRING	1	
	47	XTW3+W8TFJ	SCREW	2	
	48	XTN2+4FFJ	SCREW	1	

Safety	Ref. No.	Part No.	Part Name & Description	QTY	Remarks
	49	RKWN0024D	LCD PANEL	1	
	50	RMEN0008	CASSETTE OPEN SPRING	1	
	51	RMEN0010	MECHA COVER SPRING	1	
	52	RMQ0649	MECHA BUTTON SUPPORT	1	
	53	RMQN0015A-H	TOP COVER	1	
	54	XTN2+14GFJ	SCREW	2	
	55	XTW3+10FFJ	SCREW	3	
	56	REXN0083-1	3P CABLE WIRE (MUSIC PORT-MAIN)	1	
	58	RMCN0005-1	R/P SPRING	1	
	59	XTV3+8FFJ	SCREW	4	
	62	RMR0368-1	MECHA CHASSIS	1	
	63	RMVN0063-W	LED COVER	1	
	64	REU01R094A	1P WIRE (W3A-W3B)	1	
	65	RWJ0201100KK	1P WIRE (W1A-W1B)	1	
	66	RWJ0201200KK	1P WIRE (W2A-W2B)	1	
	67	REEN0026	22P FFC (USB-MAIN)	1	
	68	RMKN0013	USB HOLDER	1	
	69	RMVN0067	MAIN PCB SAFETY COVER	1	
			CASSETTE DECK		
	101	RDV0021-1	CAPSTAN BELT	1	
	102	RXX0215-J1	MECHA CHASSIS ASS'Y	1	
	103	RFKPD45EG-W	MOTOR ASS'Y	1	
	104	RBR4CM006-T	R/P HEAD	1	
	105	RD-JHP001-N1	ERASE HEAD	1	
	106	RHD20049-1	SCREW	1	
	107	RHD26002-1	SCREW	2	
	108	RJR0033	EARTH LUG	1	
	109	RMA0108-1	MOTOR BRACKET A	1	
	110	RMB0059	AZIMUTH SPRING	1	
	111	REXN0021	4P WIRE	1	
	112	RMG0102-1	MOTOR CUSHION	2	
	113	RML0080-2	ERASE HEAD ARM	1	
	114	RMR0149-1	HEAD BASE	1	
	115	XTN2+4FFJ	SCREW	1	
	116	XTN2+8FFJ	SCREW	1	
	117	XTN26+8JFJ	SCREW	1	
			TRAVERSE DECK		
△	401	RD-DAPX001-V	TRAVERSE UNIT	1	
	410	XTN2+6GFJ	SCREW	3	
			PACKING MATERIALS		
	P1	RPGX3061	PACKING CASE	1	
	P2	RPNX1014-1	POLYFOAM	1	
	P3	RPFN0004	MIRAMAT SHEET	1	
			ACCESSORIES		
	A1	N2QAYA000008	REMOTE CONTROL	1	
	A1-1	RKK-PT470EBK	R/C BATTERY COVER	1	
△	A2	K2CQ2CA00007	AC CORD	1	
△	A3	RQTX1037-R	O/I BOOK (Ru/Ur)	1	

8.2. Electrical Replacement Parts List

Important Safety Notice

Components identified by \triangle mark have special characteristics important for safety. When replacing any of these components, use only manufacturer's specified parts.

RTL (Retention Time Limited)

Note: The marking (RTL) indicates that the Retention Time is Limited for this item. After the discontinuation of this assembly in production, the item will continue to be available for a specific period of time. The retention period of availability is dependant on the type of assembly, and in accordance with the laws governing part and product retention. After the end of this period, the assembly will no longer be available.

Note:

- When replacing any of these components, be sure to use only manufacturer's specified parts shown in the replacement part list.
- The parenthesized indications on the Remarks column specify the destination & product color (Refer to the cover page for the information).
- Parts without these indications shall be used for all areas.
- This product uses a laser diode. Refer to "Precaution of Laser Diode".
- Capacitor value are in microfarads (uF) unless specified otherwise, P=Pico-farads (pF), F=Farads.
- Resistance values are in ohms, unless specified otherwise, 1K=1000 (OHM).
- All parts mentioned are supplied by PAVCSG unless indicated likewise.
- Parts mentioned [SPG] in the Remarks column are supplied by PAVC-CSG.

Safety	Ref. No.	Part No.	Part Name & Description	QTY	Remarks
			PRINTED CIRCUIT BOARDS		
	PCB1	REPNT0065BA	MAIN P.C.B.	1	(RTL)
\triangle	PCB3	REPNT0063H	POWER P.C.B.	1	(RTL)
	PCB6	REPNT0065BB	DECK P.C.B.	1	(RTL)
	PCB9	REPNT0063H	BATTERY P.C.B. (1)	1	(RTL)
	PCB10	REPNT0063H	BATTERY P.C.B. (2)	1	(RTL)
	PCB11	REPNT0065BC	MUSIC PORT P.C.B.	1	(RTL)
			INTEGRATED CIRCUITS		
	IC4100	C0CBABE00040	IC	1	
			DIODES		

Safety	Ref. No.	Part No.	Part Name & Description	QTY	Remarks
	D5927	B0ACCK000005	DIODE	1	
	D5928	B0EAKM000117	DIODE	1	
	D5929	B0EAKM000117	DIODE	1	
	D5930	B0EAKM000117	DIODE	1	
	D5931	B0EAKM000117	DIODE	1	
			RESISTORS		
	R2115	ERJ3GEYF224V	220K 1/10W	1	
	R5910	ERJ3GEYJ473V	47K 1/10W	1	
	R5917	ERJ3GEYJ103V	10K 1/10W	1	POWER
	R5938	ERJ3GEYF154V	150K 1/10W	1	
			CAPACITORS		
	C4111	F2A1E471A121	470uF 25V	1	
	C5908	ERJ3GEY0R00V	0 1/10W	1	

FLE1005