



# LG

Life's Good

North/Latin America  
Europe/Africa  
Asia/Oceania

Internal Use Only

<http://aic.lgservice.com>  
<http://eic.lgservice.com>  
<http://biz.lgservice.com>

# LED TV

# SERVICE MANUAL

**CHASSIS : LD48V**

**MODEL : 42UB820V    42UB820V-ZH**  
**42UB828V    42UB828V-ZH**

## CAUTION

BEFORE SERVICING THE CHASSIS,  
READ THE SAFETY PRECAUTIONS IN THIS MANUAL.

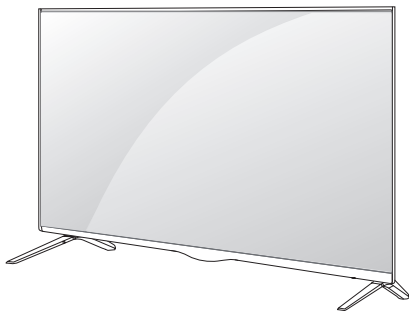

# CONTENTS

<b>CONTENTS .....</b>	<b>2</b>
<b>SAFETY PRECAUTIONS .....</b>	<b>3</b>
<b>SERVICING PRECAUTIONS.....</b>	<b>4</b>
<b>SPECIFICATION .....</b>	<b>6</b>
<b>ADJUSTMENT INSTRUCTION .....</b>	<b>15</b>
<b>BLOCK DIAGRAM.....</b>	<b>23</b>
<b>EXPLODED VIEW .....</b>	<b>24</b>
<b>SCHEMATIC CIRCUIT DIAGRAM .....</b>	

# SAFETY PRECAUTIONS

## IMPORTANT SAFETY NOTICE

Many electrical and mechanical parts in this chassis have special safety-related characteristics. These parts are identified by  $\triangle$  in the Schematic Diagram and Exploded View.

It is essential that these special safety parts should be replaced with the same components as recommended in this manual to prevent Shock, Fire, or other Hazards.

Do not modify the original design without permission of manufacturer.

### General Guidance

An **isolation Transformer should always be used** during the servicing of a receiver whose chassis is not isolated from the AC power line. Use a transformer of adequate power rating as this protects the technician from accidents resulting in personal injury from electrical shocks.

It will also protect the receiver and its components from being damaged by accidental shorts of the circuitry that may be inadvertently introduced during the service operation.

If any fuse (or Fusible Resistor) in this TV receiver is blown, replace it with the specified.

When replacing a high wattage resistor (Oxide Metal Film Resistor, over 1 W), keep the resistor 10 mm away from PCB.

Keep wires away from high voltage or high temperature parts.

### Before returning the receiver to the customer,

always perform an **AC leakage current check** on the exposed metallic parts of the cabinet, such as antennas, terminals, etc., to be sure the set is safe to operate without damage of electrical shock.

### Leakage Current Cold Check(Antenna Cold Check)

With the instrument AC plug removed from AC source, connect an electrical jumper across the two AC plug prongs. Place the AC switch in the on position, connect one lead of ohm-meter to the AC plug prongs tied together and touch other ohm-meter lead in turn to each exposed metallic parts such as antenna terminals, phone jacks, etc.

If the exposed metallic part has a return path to the chassis, the measured resistance should be between 1 M $\Omega$  and 5.2 M $\Omega$ .

When the exposed metal has no return path to the chassis the reading must be infinite.

An other abnormality exists that must be corrected before the receiver is returned to the customer.

### Leakage Current Hot Check (See below Figure)

Plug the AC cord directly into the AC outlet.

### Do not use a line Isolation Transformer during this check.

Connect 1.5 K / 10 watt resistor in parallel with a 0.15 uF capacitor between a known good earth ground (Water Pipe, Conduit, etc.) and the exposed metallic parts.

Measure the AC voltage across the resistor using AC voltmeter with 1000 ohms/volt or more sensitivity.

Reverse plug the AC cord into the AC outlet and repeat AC voltage measurements for each exposed metallic part. Any voltage measured must not exceed 0.75 volt RMS which corresponds to 0.5 mA.

In case any measurement is out of the limits specified, there is possibility of shock hazard and the set must be checked and repaired before it is returned to the customer.

### Leakage Current Hot Check circuit

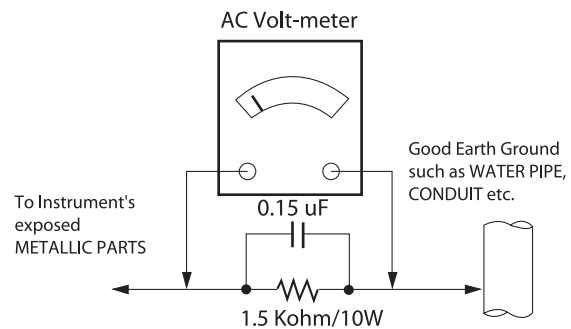

When 25A is impressed between Earth and 2nd Ground for 1 second, Resistance must be less than 0.1  $\Omega$

\*Base on Adjustment standard

# SERVICING PRECAUTIONS

**CAUTION:** Before servicing receivers covered by this service manual and its supplements and addenda, read and follow the **SAFETY PRECAUTIONS** on page 3 of this publication.  
**NOTE:** If unforeseen circumstances create conflict between the following servicing precautions and any of the safety precautions on page 3 of this publication, always follow the safety precautions. Remember: Safety First.

## General Servicing Precautions

1. Always unplug the receiver AC power cord from the AC power source before;
  - a. Removing or reinstalling any component, circuit board module or any other receiver assembly.
  - b. Disconnecting or reconnecting any receiver electrical plug or other electrical connection.
  - c. Connecting a test substitute in parallel with an electrolytic capacitor in the receiver.  
**CAUTION:** A wrong part substitution or incorrect polarity installation of electrolytic capacitors may result in an explosion hazard.
2. Test high voltage only by measuring it with an appropriate high voltage meter or other voltage measuring device (DVM, FETVOM, etc) equipped with a suitable high voltage probe. Do not test high voltage by "drawing an arc".
3. Do not spray chemicals on or near this receiver or any of its assemblies.
4. Unless specified otherwise in this service manual, clean electrical contacts only by applying the following mixture to the contacts with a pipe cleaner, cotton-tipped stick or comparable non-abrasive applicator; 10 % (by volume) Acetone and 90 % (by volume) isopropyl alcohol (90 % - 99 % strength)  
**CAUTION:** This is a flammable mixture.  
Unless specified otherwise in this service manual, lubrication of contacts is not required.
5. Do not defeat any plug/socket B+ voltage interlocks with which receivers covered by this service manual might be equipped.
6. Do not apply AC power to this instrument and/or any of its electrical assemblies unless all solid-state device heat sinks are correctly installed.
7. Always connect the test receiver ground lead to the receiver chassis ground before connecting the test receiver positive lead.  
Always remove the test receiver ground lead last.
8. Use with this receiver only the test fixtures specified in this service manual.  
**CAUTION:** Do not connect the test fixture ground strap to any heat sink in this receiver.

## Electrostatically Sensitive (ES) Devices

Some semiconductor (solid-state) devices can be damaged easily by static electricity. Such components commonly are called Electrostatically Sensitive (ES) Devices. Examples of typical ES devices are integrated circuits and some field-effect transistors and semiconductor "chip" components. The following techniques should be used to help reduce the incidence of component damage caused by static by static electricity.

1. Immediately before handling any semiconductor component or semiconductor-equipped assembly, drain off any electrostatic charge on your body by touching a known earth ground. Alternatively, obtain and wear a commercially available discharging wrist strap device, which should be removed to prevent potential shock reasons prior to applying power to the unit under test.

2. After removing an electrical assembly equipped with ES devices, place the assembly on a conductive surface such as aluminum foil, to prevent electrostatic charge buildup or exposure of the assembly.
3. Use only a grounded-tip soldering iron to solder or unsolder ES devices.
4. Use only an anti-static type solder removal device. Some solder removal devices not classified as "anti-static" can generate electrical charges sufficient to damage ES devices.
5. Do not use freon-propelled chemicals. These can generate electrical charges sufficient to damage ES devices.
6. Do not remove a replacement ES device from its protective package until immediately before you are ready to install it. (Most replacement ES devices are packaged with leads electrically shorted together by conductive foam, aluminum foil or comparable conductive material).
7. Immediately before removing the protective material from the leads of a replacement ES device, touch the protective material to the chassis or circuit assembly into which the device will be installed.  
**CAUTION:** Be sure no power is applied to the chassis or circuit, and observe all other safety precautions.
8. Minimize bodily motions when handling unpackaged replacement ES devices. (Otherwise harmless motion such as the brushing together of your clothes fabric or the lifting of your foot from a carpeted floor can generate static electricity sufficient to damage an ES device.)

## General Soldering Guidelines

1. Use a grounded-tip, low-wattage soldering iron and appropriate tip size and shape that will maintain tip temperature within the range of 500 °F to 600 °F.
2. Use an appropriate gauge of RMA resin-core solder composed of 60 parts tin/40 parts lead.
3. Keep the soldering iron tip clean and well tinned.
4. Thoroughly clean the surfaces to be soldered. Use a mall wire-bristle (0.5 inch, or 1.25 cm) brush with a metal handle. Do not use freon-propelled spray-on cleaners.
5. Use the following unsoldering technique
  - a. Allow the soldering iron tip to reach normal temperature. (500 °F to 600 °F)
  - b. Heat the component lead until the solder melts.
  - c. Quickly draw the melted solder with an anti-static, suction-type solder removal device or with solder braid.  
**CAUTION:** Work quickly to avoid overheating the circuit board printed foil.
6. Use the following soldering technique.
  - a. Allow the soldering iron tip to reach a normal temperature (500 °F to 600 °F)
  - b. First, hold the soldering iron tip and solder the strand against the component lead until the solder melts.
  - c. Quickly move the soldering iron tip to the junction of the component lead and the printed circuit foil, and hold it there only until the solder flows onto and around both the component lead and the foil.  
**CAUTION:** Work quickly to avoid overheating the circuit board printed foil.
  - d. Closely inspect the solder area and remove any excess or splashed solder with a small wire-bristle brush.

### IC Remove/Replacement

Some chassis circuit boards have slotted holes (oblong) through which the IC leads are inserted and then bent flat against the circuit foil. When holes are the slotted type, the following technique should be used to remove and replace the IC. When working with boards using the familiar round hole, use the standard technique as outlined in paragraphs 5 and 6 above.

#### Removal

1. Desolder and straighten each IC lead in one operation by gently prying up on the lead with the soldering iron tip as the solder melts.
2. Draw away the melted solder with an anti-static suction-type solder removal device (or with solder braid) before removing the IC.

#### Replacement

1. Carefully insert the replacement IC in the circuit board.
2. Carefully bend each IC lead against the circuit foil pad and solder it.
3. Clean the soldered areas with a small wire-bristle brush. (It is not necessary to reapply acrylic coating to the areas).

### "Small-Signal" Discrete Transistor Removal/Replacement

1. Remove the defective transistor by clipping its leads as close as possible to the component body.
2. Bend into a "U" shape the end of each of three leads remaining on the circuit board.
3. Bend into a "U" shape the replacement transistor leads.
4. Connect the replacement transistor leads to the corresponding leads extending from the circuit board and crimp the "U" with long nose pliers to insure metal to metal contact then solder each connection.

### Power Output, Transistor Device

#### Removal/Replacement

1. Heat and remove all solder from around the transistor leads.
2. Remove the heat sink mounting screw (if so equipped).
3. Carefully remove the transistor from the heat sink of the circuit board.
4. Insert new transistor in the circuit board.
5. Solder each transistor lead, and clip off excess lead.
6. Replace heat sink.

### Diode Removal/Replacement

1. Remove defective diode by clipping its leads as close as possible to diode body.
2. Bend the two remaining leads perpendicular y to the circuit board.
3. Observing diode polarity, wrap each lead of the new diode around the corresponding lead on the circuit board.
4. Securely crimp each connection and solder it.
5. Inspect (on the circuit board copper side) the solder joints of the two "original" leads. If they are not shiny, reheat them and if necessary, apply additional solder.

### Fuse and Conventional Resistor

#### Removal/Replacement

1. Clip each fuse or resistor lead at top of the circuit board hollow stake.
2. Securely crimp the leads of replacement component around notch at stake top.

3. Solder the connections.

**CAUTION:** Maintain original spacing between the replaced component and adjacent components and the circuit board to prevent excessive component temperatures.

### Circuit Board Foil Repair

Excessive heat applied to the copper foil of any printed circuit board will weaken the adhesive that bonds the foil to the circuit board causing the foil to separate from or "lift-off" the board. The following guidelines and procedures should be followed whenever this condition is encountered.

#### At IC Connections

To repair a defective copper pattern at IC connections use the following procedure to install a jumper wire on the copper pattern side of the circuit board. (Use this technique only on IC connections).

1. Carefully remove the damaged copper pattern with a sharp knife. (Remove only as much copper as absolutely necessary).
2. Carefully scratch away the solder resist and acrylic coating (if used) from the end of the remaining copper pattern.
3. Bend a small "U" in one end of a small gauge jumper wire and carefully crimp it around the IC pin. Solder the IC connection.
4. Route the jumper wire along the path of the out-away copper pattern and let it overlap the previously scraped end of the good copper pattern. Solder the overlapped area and clip off any excess jumper wire.

#### At Other Connections

Use the following technique to repair the defective copper pattern at connections other than IC Pins. This technique involves the installation of a jumper wire on the component side of the circuit board.

1. Remove the defective copper pattern with a sharp knife. Remove at least 1/4 inch of copper, to ensure that a hazardous condition will not exist if the jumper wire opens.
2. Trace along the copper pattern from both sides of the pattern break and locate the nearest component that is directly connected to the affected copper pattern.
3. Connect insulated 20-gauge jumper wire from the lead of the nearest component on one side of the pattern break to the lead of the nearest component on the other side. Carefully crimp and solder the connections.

**CAUTION:** Be sure the insulated jumper wire is dressed so the it does not touch components or sharp edges.

# SPECIFICATION

NOTE : Specifications and others are subject to change without notice for improvement.

## 1. Application range

This specification is applied to the LED TV used LD48V chassis.

## 2. Requirement for Test

Each part is tested as below without special appointment.

- 1) Temperature: 25 °C ± 5 °C(77 °F ± 9 °F), CST: 40 °C ± 5 °C
- 2) Relative Humidity: 65 % ± 10 %
- 3) Power Voltage  
: Standard input voltage (AC 100-240 V~, 50/60 Hz)  
\* Standard Voltage of each products is marked by models.
- 4) Specification and performance of each parts are followed each drawing and specification by part number in accordance with BOM.
- 5) The receiver must be operated for about 5 minutes prior to the adjustment.

## 3. Test method

- 1) Performance: LGE TV test method followed
- 2) Demanded other specification
  - Safety : CE, IEC specification
  - EMC : CE, IEC specification
  - Wireless : Wireless HD Specification (Option)

## 4. Model General Specification

No.	Item	Specification	Remarks
1	Market	EU(PAL Market-36Countries)/CIS + Morocco(Africa)	<p><b>DTV &amp; Analog (Total 37 countries)</b></p> <p><b>DTV (MPEG2/4, DVB-T) : 30 countries</b> Germany, Netherland, Switzerland, Hungary, Austria, Slovenia, Bulgaria, France, Spain, Italy, Belgium, Russia, Luxemburg, Greece, Czech, Croatia, Turkey, Morocco, Ireland, Latvia, Estonia, Lithuania, Poland, Portugal, Romania, Albania, Bosnia, Serbia, Slovakia, Belarus</p> <p><b>DTV (MPEG2/4, DVB-T2) : 8 countries</b> UK(Ireland), Sweden, Denmark, Finland, Norway, Ukraine, Kazakhstan, Russia</p> <p><b>DTV (MPEG2/4, DVB-C) : 37 countries</b> Germany, Netherland, Switzerland, Hungary, Austria, Slovenia, Bulgaria, France, Spain, Italy, Belgium, Russia, Luxemburg, Greece, Czech, Croatia, Turkey, Morocco, Ireland, Latvia, Estonia, Lithuania, Poland, Portugal, Romania, Albania, Bosnia, Serbia, Slovakia, Belarus, UK, Sweden, Denmark, Finland, Norway, Ukraine, Kazakhstan</p> <p><b>DTV (MPEG2/4, DVB-S/S2) : 30 countries</b> Germany, Netherland, Switzerland, Hungary, Austria, Slovenia, Bulgaria, France, Spain, Italy, Belgium, Russia, Luxemburg, Greece, Czech, Croatia, Turkey, Morocco, Ireland, Latvia, Estonia, Lithuania, Poland, Portugal, Romania, Albania, Bosnia, Serbia, Slovakia, Belarus, UK, Sweden, Denmark, Finland, Norway, Ukraine, Kazakhstan</p> <p><b>Supported satellite : 29 satellites</b> ABS1 75.0E/ AMOS 4.0W/ ASIATSATS 105.5E/ ASTRA1LHMKR 19.2E/ ASTRA2ABD 28.2E/ ASTRA3AB 23.5E/ ASTRA4A 4.8E/ ATLANTIC-BIRD2 8.0W/ ATLANTICBIRD3 5.0W/ BADR 26.0E/ EUROBIRD3 33.0E/ EUROBIRD9A 9.0E/ EUTELSATW2A 10.E/ EUTELSATW3A 7.0E/ EUTELSATW4W7 36.0E/ EUTELSESAT 16.0E/ EXPRESSAM1 40.0E/ EXPRESAM3 140.0E/ EXPRESSAM33 96.5E/ HELLASAT2 39.0E/ HISPASAT1CDE 30.0W/ HOTBIRD 13.0E/ INTELSAT10&amp;7 68.5E/ INTELSAT15 85.2E/ INTELSAT904 60.0E/ NILESAT 7.0W/ THOR 0.8W/ TURKSAT 42.0E/ YAMAL201 90.0E</p>

No.	Item	Specification	Remarks
2	Broadcasting system	(1) PAL-BG/DK/I/I' (2) SECAM L/L', DK, BG, I (3) DVB-T/T2, C, S/S2	
3	Program coverage	(1) Digital TV - VHF, UHF - C-Band, Ku-Band (2) Analogue TV -VHF : E2 to E12 -UHF : E21 to E69 -CATV : S1 to S20 -HYPER : S21 to S47	
4	Receiving system	Analog : Upper Heterodyne Digital : COFDM, QAM	<p>▶ DVB-T</p> <ul style="list-style-type: none"> <li>- Guard Interval(Bitrate_Mbit/s) 1/4, 1/8, 1/16, 1/32</li> <li>- Modulation : Code Rate</li> <li>QPSK : 1/2, 2/3, 3/4, 5/6, 7/8</li> <li>16-QAM : 1/2, 2/3, 3/4, 5/6, 7/8</li> <li>64-QAM : 1/2, 2/3, 3/4, 5/6, 7/8</li> </ul> <p>▶ DVB-T2</p> <ul style="list-style-type: none"> <li>- Guard Interval(Bitrate_Mbit/s) 1/4, 1/8, 1/16, 1/32, 1/128, 19/128, 19/256,</li> <li>- Modulation : Code Rate</li> <li>QPSK : 1/2, 2/5, 2/3, 3/4, 5/6</li> <li>16-QAM : 1/2, 2/5, 2/3, 3/4, 5/6</li> <li>64-QAM : 1/2, 2/5, 2/3, 3/4, 5/6</li> <li>256-QAM : 1/2, 2/5, 2/3, 3/4, 5/6</li> </ul> <p>▶ DVB-C</p> <ul style="list-style-type: none"> <li>- Symbolrate : 4.0 Msymbols/s to 7.2 Msymbols/s</li> <li>- Modulation : 16QAM, 64-QAM, 128-QAM and 256-QAM</li> </ul> <p>▶ DVB-S/S2</p> <ul style="list-style-type: none"> <li>- symbolrate :</li> <li>DVB-S2 (8PSK / QPSK) : 2 ~ 45 Msymbol/s</li> <li>DVB-S (QPSK) : 2 ~ 45 Msymbol/s</li> <li>- viterbi</li> <li>DVB-S mode : 1/2, 2/3, 3/4, 5/6, 7/8</li> <li>DVB-S2 mode : 1/2, 2/3, 3/4, 3/5, 4/5, 5/6, 8/9, 9/10</li> </ul>
5	Input Voltage	AC 100 ~ 240 V, 50/60 Hz	

## 5. External Input Format

### 5.1. Component (Y, P<sub>B</sub>, P<sub>R</sub>)

No.	Resolution	H-freq(kHz)	V-freq(Hz)	Pixel clock(MHz)	Proposed
1.	720*480i	15.73	59.94	13.50	SDTV, DVD 480I(525I)
2	720*480i	15.73	60.00	13.51	SDTV, DVD 480I(525I)
3.	720*576i	15.63	50.00	13.50	SDTV, DVD 576I(625I) 50Hz
4	720*480p	31.47	59.94	27.00	SDTV 480P
5	720*480p	31.50	60.00	27.03	SDTV 480P
6	720*576p	31.25	50.00	27.00	SDTV 576P 50Hz
7	1280*720	44.96	59.94	74.18	HDTV 720P
8	1280*720	45.00	60.00	74.25	HDTV 720P
9	1280*720	45.00	50.00	74.25	HDTV 720P 50Hz
10	1920*1080	28.13	50.00	74.25	HDTV 1080I 50Hz,
11	1920*1080	33.72	59.94	74.18	HDTV 1080I
12	1920*1080	33.75	60.00	74.25	HDTV 1080I
13	1920*1080	56.25	50.00	148.50	HDTV 1080P
14	1920*1080	67.50	60.00	148.50	HDTV 1080P



## 5.2. HDMI(PC/DTV) (1) DTV mode

No.	Resolution	H-freq(kHz)	V-freq.(kHz)	Pixel clock(MHz)	Proposed	Remarks
1	640*480	31.47	59.94	25.13	SDTV 480P	
2	640*480	31.50	60.00	25.13	SDTV 480P	
3	720*480	15.73	59.94	13.50	SDTV, DVD 480I(525I)	Spec. out but display
4	720*480	15.75	60.00	13.51	SDTV, DVD 480I(525I)	
5	720*576	15.63	50.00	13.50	SDTV, DVD 576I(625I) 50Hz	
6	720*480	31.47	59.94	27.00	SDTV 480P	
7	720*480	31.50	60.00	27.03	SDTV 480P	
8	720*576	31.25	50.00	27.00	SDTV 576P	
9	1280*720	44.96	59.94	74.18	HDTV 720P	
10	1280*720	45.00	60.00	74.25	HDTV 720P	
11	1280*720	37.50	50.00	74.25	HDTV 720P	
12	1920*1080	28.13	50.00	74.25	HDTV 1080I	
13	1920*1080	33.72	59.94	74.18	HDTV 1080I	
14	1920*1080	33.75	60.00	74.25	HDTV 1080I	
15	1920*1080	26.97	23.98	63.30	HDTV 1080P	
16	1920*1080	27.00	24.00	63.36	HDTV 1080P	
17	1920*1080	33.71	29.97	79.12	HDTV 1080P	
18	1920*1080	33.75	30.00	79.20	HDTV 1080P	
19	1920*1080	56.25	50.00	148.50	HDTV 1080P	
20	1920*1080	67.43	59.94	148.35	HDTV 1080P	
21	1920*1080	67.50	60.00	148.50	HDTV 1080P	
22	3840*2160	53.95	23.98	297.00	UDTV 2160P	
23	3840*2160	54.00	24.00	297.00	UDTV 2160P	
24	3840*2160	56.25	25.00	297.00	UDTV 2160P	
25	3840*2160	61.43	29.97	297.00	UDTV 2160P	
26	3840*2160	67.50	30.00	297.00	UDTV 2160P	
27	3840*2160	112.50	50.00	594.00	UDTV 2160P	8 bit / YCbCr 4:2:0
28	3840*2160	135.00	59.94	593.41	UDTV 2160P	8 bit / YCbCr 4:2:0
29	3840*2160	135.00	60.00	594.00	UDTV 2160P	8 bit / YCbCr 4:2:0
30	4096*2160	53.95	23.98	297.00	UDTV 2160P	
31	4096*2160	54.00	24.00	297.00	UDTV 2160P	
32	4096*2160	56.25	25.00	297.00	UDTV 2160P	
33	4096*2160	61.43	29.97	297.00	UDTV 2160P	
34	4096*2160	67.50	30.00	297.00	UDTV 2160P	
35	4096*2160	112.50	50.00	594.00	UDTV 2160P	8 bit / YCbCr 4:2:0
36	4096*2160	135.00	59.94	593.41	UDTV 2160P	8 bit / YCbCr 4:2:0
37	4096*2160	135.00	60.00	594.00	UDTV 2160P	8 bit / YCbCr 4:2:0

**(2) PC mode**

No.	Resolution	H-freq(kHz)	V-freq.(kHz)	Pixel clock(MHz)	Proposed	Remarks
1	640*350	31.47	70.09	25.17	EGA	
2	720*400	31.47	70.08	28.32	DOS	
3	640*480	31.47	59.94	25.17	VESA(VGA)	
4	800*600	37.88	60.32	40.00	VESA(SVGA)	
5	1024*768	48.36	60.00	65.00	VESA(XGA)	
6	1360*768	47.71	60.02	84.75	VESA(WXGA)	
7	1152*864	54.35	60.05	80.00	VESA	
8	1280*1024	63.98	60.02	109.00	SXGA	
9	1920*1080	67.50	60.00	158.40	WUXGA(Reduced Blanking)	
10	3840*2160	54.00	24.00	297.00	UDTV 2160P	
11	3840*2160	56.25	25.00	297.00	UDTV 2160P	
12	3840*2160	67.50	30.00	297.00	UDTV 2160P	
13	4096*2160	53.95	23.98	297.00	UDTV 2160P	
14	4096*2160	54.00	24.00	297.00	UDTV 2160P	

## 6. 3D Mode

### 6.1. RF Input

No.	Resolution	H-freq(kHz)	V-freq.(kHz)	Pixel clock(MHz)	Proposed	Remarks
1	1280*720	37.500	50	74.25	HDTV 720P	2D to 3D, Side by Side, Top & Bottom
2	1920*1080	28.125	50	74.25	HDTV 1080I	2D to 3D, Side by Side, Top & Bottom

### 6.2. HDMI Input

(1) HDMI 1.4/2.0(3D Supported mode manually)

No.	Resolution	H-freq(kHz)	V-freq.(kHz)	Pixel clock(MHz)	Proposed	3D input proposed mode
1	720*480	31.50	60.00	27.03	SDTV 480P	
2	720*576	31.25	50.00	27.00	SDTV 576P	2D to 3D, Side by Side(Half), Top & Bottom, Checker Board, Frame Sequential, Row Interleaving, Column Interleaving
3	1280*720	45.00	60.00	74.25	HDTV 720P	
		37.50	50.00	74.25	HDTV 720P	
4	1920*1080	33.75	60.00	74.25	HDTV 1080I	2D to 3D, Side by Side(Half), Top & Bottom
		28.13	50.00	74.25	HDTV 1080I	
		27.00	24.00	74.25	HDTV 1080P	2D to 3D, Side by Side(Half), Top & Bottom, Checker Board, Row Interleaving, Column Interleaving
		28.12	25.00	74.25	HDTV 1080P	
		33.75	30.00	74.25	HDTV 1080P	
		67.50	60.00	148.50	HDTV 1080P	
5	3840*2160 4096*2160	53.95	23.98	297.00	HDTV 2160P	2D to 3D, Top & Bottom(half), Side by Side(half),
		54.00	24.00	296.70		
		56.25	25.00	297.00		
		61.43	29.97	297.00		
		67.50	30.00	296.70		
		112.50	50.00	594.00	HDTV 2160P	2D to 3D, Top & Bottom(half), Side by Side(half), (8 bit, YCbCr 4:2:0)
		135.00	60.00	594.00	HDTV 2160P	

## (2) HDMI 1.4b (3D Supported mode automatically)

No.	Resolution	H-freq(kHz)	V-freq.(Hz)	Pixel clock(MHz)	VIC	3D input proposed mode	Proposed
1	640*480	31.47 / 31.50	59.94/ 60.00	25.13/25.20	1	Top-and-Bottom Side-by-side(half)	Secondary(SDTV 480P) Secondary(SDTV 480P)
		31.47 / 31.50	59.94/ 60.00	50.35/50.40	1	Side-by-side(Full)	(SDTV 480P)
		62.94 / 63.00	59.94/ 60.00	50.35/50.40	1	Frame packing Line alternative	Secondary(SDTV 480P) (SDTV 480P)
2	720*480	31.47 / 31.50	59.94 / 60.00	27.00/27.03	2,3	Top-and-Bottom Side-by-side(half)	Secondary(SDTV 480P) Secondary(SDTV 480P)
		31.47 / 31.50	59.94 / 60.00	54.00/54.06	2,3	Side-by-side(Full)	(SDTV 480P)
		62.94 /63.00	59.94 / 60.00	54.00/54.06	2,3	Frame packing Line alternative	Secondary(SDTV 480P) (SDTV 480P)
3	720*576	31.25	50.00	27.00	17,18	Top-and-Bottom Side-by-side(half)	Secondary(SDTV 576P) Secondary(SDTV 576P)
		31.25	50.00	54.00	17,18	Side-by-side(Full)	(SDTV 576P)
		62.50	50.00	54.00	17,18	Frame packing Line alternative	Secondary(SDTV 576P) (SDTV 576P)
		15.63	50.00	27.00	21	Frame packing Field alternative Side-by-side(Full) Top-and-Bottom Side-by-side(half)	Secondary(SDTV 576I) (SDTV 576I) (SDTV 576I) Secondary(SDTV 576I) Secondary(SDTV 576I)
4	1280*720	37.50	50.00	74.25	19	Top-and-Bottom Side-by-side(half)	Primary(HDTV 720P) Primary(HDTV 720P)
		37.50	50.00	148.50	19	Side-by-side(Full)	(HDTV 720P)
		44.96 / 45.00	59.94 / 60.00	74.17/74.25	4	Frame packing Line alternative	Primary(HDTV 720P) (HDTV 720P)
		44.96 / 45.00	59.94 / 60.00	148.35/148.50	4	Side-by-side(Full)	(HDTV 720P)
		75.00	50.00	148.50	19	Top-and-Bottom Side-by-side(half)	Primary(HDTV 720P) Primary(HDTV 720P)
		89.91/90.00	59.94 / 60.00	148.35/148.50	4	Frame packing Line alternative	Primary(HDTV 720P) (HDTV 720P)
5	1920*1080	28.13	50.00	74.25	20	Frame packing Line alternative	Secondary(HDTV 1080I) Primary(HDTV 1080I)
		28.13	50.00	148.50	20	Side-by-side(Full)	(HDTV 1080I)
		33.72 / 33.75	59.94 / 60.00	74.17/74.25	5	Top-and-Bottom Side-by-side(half)	Secondary(HDTV 1080I) Primary(HDTV 1080I)
		33.72 / 33.75	59.94 / 60.00	148.35/148.50	5	Side-by-side(Full)	(HDTV 1080I)
		56.25	50.00	148.50	20	Frame packing Field alternative	Primary(HDTV 1080I) (HDTV 1080I)
		67.43/67.50	59.94 / 60.00	148.35/148.50	5	Frame packing Field alternative	Primary(HDTV 1080I) (HDTV 1080I)
		26.97 / 27.00	23.97 / 24.00	74.17 / 74.25	32	Top-and-Bottom Side-by-side(half)	Primary(HDTV 1080P) Primary(HDTV 1080P)
		26.97 / 27.00	23.97 / 24.00	148.35 / 148.50	32	Side-by-side(Full)	(HDTV 1080P)
		28.12	25.00	74.25	33	Top-and-Bottom Side-by-side(half)	Secondary(HDTV 1080P) Secondary(HDTV 1080P)
		28.12	25.00	148.50	33	Side-by-side(Full)	(HDTV 1080P)
		33.72 / 33.75	29.98 / 30.00	74.18/74.25	34	Side-by-side(Full)	(HDTV 1080P)
		33.72 / 33.75	29.98 / 30.00	148.35/148.50	34	Frame packing Line alternative	Primary(HDTV 1080P) (HDTV 1080P)
		43.94/54.00	23.97 / 24.00	148.35/148.50	32	Frame packing Line alternative	Secondary(HDTV 1080P) (HDTV 1080P)
		56.25	25.00	148.50	33	Frame packing Line alternative	Primary(HDTV 1080P) (HDTV 1080P)
		67.43 / 67.5	29.98 / 30.00	148.35/148.50	34	Frame packing Line alternative	Primary(HDTV 1080P) (HDTV 1080P)
56.25	50.00	148.50	31	Top-and-Bottom Side-by-side(half)	Primary(HDTV 1080P) Secondary(HDTV 1080P)		
67.43 / 67.50	59.94 / 60.00	148.35/148.50	16	Top-and-Bottom Side-by-side(half)	Primary(HDTV 1080P) Secondary(HDTV 1080P)		

(3) HDMI-PC Input (3D) (3D Supported mode manually)

No.	Resolution	H-freq(kHz)	V-freq.(kHz)	Pixel clock(MHz)	Proposed	3D input proposed mode
1	1024*768	48.36	60.00	65.00	HDTV 768P	2D to 3D, Side by Side(half), Top & Bottom
2	1920*1080	67.500	60	148.50	HDTV 1080P	2D to 3D, Side by Side(half), Top & Bottom, Checker Board, Single Frame Sequential, Row Interleaving, Column Interleaving
3	3840*2160	54.00	24.00	296.70	HDTV 2160P	2D to 3D, Top & Bottom(half), Side by Side(half),
		56.25	25.00	297.00		
		67.50	30.00	296.70		
4	4096*2160	54	24.00	297.00	HDTV 2160P	2D to 3D, Top & Bottom(half), Side by Side(half),
5	Others	-	-	-	640*350 720*400 640*480 800*600 1152*864	2D to 3D, Side by Side(half), Top & Bottom

(4) Component Input (3D) (3D Supported mode manually)

No.	Resolution	H-freq(kHz)	V-freq.(kHz)	Pixel clock(MHz)	Proposed	3D input proposed mode
1	1280*720	37.50	50.00	74.25	HDTV 720P	2D to 3D, Side by Side(half), Top & Bottom
2	1280*720	45.00	60.00	74.25	HDTV 720P	2D to 3D, Side by Side(half), Top & Bottom
3	1280*720	44.96	59.94	74.18	HDTV 720P	2D to 3D, Side by Side(half), Top & Bottom
4	1920*1080	33.75	60.00	74.25	HDTV 1080I	2D to 3D, Side by Side(half), Top & Bottom
5	1920*1080	33.72	59.94	74.18	HDTV 1080I	2D to 3D, Side by Side(half), Top & Bottom
6	1920*1080	28.12	50.00	74.25	HDTV 1080I	2D to 3D, Side by Side(half), Top & Bottom
7	1920*1080	67.50	60.00	148.50	HDTV 1080P	2D to 3D, Side by Side(half), Top & Bottom
8	1920*1080	67.43	59.94	148.35	HDTV 1080P	2D to 3D, Side by Side(half), Top & Bottom
9	1920*1080	27.00	24.00	74.25	HDTV 1080P	2D to 3D, Side by Side(half), Top & Bottom
10	1920*1080	28.12	25.00	74.25	HDTV 1080P	2D to 3D, Side by Side(half), Top & Bottom
11	1920*1080	56.25	50.00	74.25	HDTV 1080P	2D to 3D, Side by Side(half), Top & Bottom
12	1920*1080	26.97	23.98	74.18	HDTV 1080P	2D to 3D, Side by Side(half), Top & Bottom
13	1920*1080	33.75	30.00	74.25	HDTV 1080P	2D to 3D, Side by Side(half), Top & Bottom
14	1920*1080	33.71	29.97	74.18	HDTV 1080P	2D to 3D, Side by Side(half), Top & Bottom

### 6.3. USB - Movie (3D) (3D supported mode manually)

No.	Resolution	H-freq(kHz)	V-freq.(Hz)	Pixel clock(MHz)	3D input proposed mode
1	Under 704x480	-	-	-	2D to 3D
2	Over 704x480 Under 1080P interlaced	-	-	-	2D to 3D, Side by Side(Half), Top & Bottom
3	Over 704x480 Under 1080P progressive	-	50 / 60	-	2D to 3D, Side by Side(Half), Top & Bottom, Checker Board, Row Interleaving, Column Interleaving, Frame Sequential
		-	others	-	2D to 3D, Side by Side(Half), Top & Bottom, Checker Board, Row Interleaving, Column Interleaving
4	Over 2160P	-	24/25/30	-	2D to 3D, Side by Side(Half), Top & Bottom

### 6.4. USB, DLNA - Photo (3D) (3D supported mode manually)

No.	Resolution	H-freq(kHz)	V-freq.(Hz)	Pixel clock(MHz)	3D input proposed mode
1	Under 320x240	-	-	-	2D to 3D
2	Over 320x240	-	-	-	2D to 3D, Side by Side(Half), Top & Bottom









### 6.5. USB, DLNA (3D) (3D supported mode automatically)

No.	Resolution	H-freq(kHz)	V-freq.(Hz)	Pixel clock(MHz)	3D input proposed mode
1	1080p	33.75	30.00	74.25	Side by Side(Half), Top & Bottom, Checker Board MPO(Photo), JPS(Photo)
2	2160p	67.50	30.00	297.00	

### 6.6. Miracast, Widi (3D supported mode manually)

No.	Resolution	H-freq(kHz)	V-freq.(Hz)	Pixel clock(MHz)	3D input proposed mode
1	1024*768p	-	30/60	-	2D to 3D, Side by Side(Half), Top & Bottom
2	1280*720p	-	30/60	-	
3	1920*1080p	-	30/60	-	
4	Others	-	-	-	2D to 3D

■ Remark: 3D Input mode

No.	Side by Side	Top & Bottom	Checker board	Single Frame Sequential	Frame Packing	Line Interleaving	Column Interleaving	2D to 3D
1								

# ADJUSTMENT INSTRUCTION

## 1. Application Range

This specification sheet is applied to all of the LED TV with LD48V chassis.

## 2. Designation

- (1) Because this is not a hot chassis, it is not necessary to use an isolation transformer. However, the use of isolation transformer will help protect test instrument.
- (2) Adjustment must be done in the correct order.
- (3) The adjustment must be performed in the circumstance of  $25\text{ }^{\circ}\text{C} \pm 5\text{ }^{\circ}\text{C}$  of temperature and  $65\% \pm 10\%$  of relative humidity if there is no specific designation.
- (4) The input voltage of the receiver must keep AC 100-240 V~, 50/60 Hz.
- (5) The receiver must be operated for about 5 minutes prior to the adjustment when module is in the circumstance of over 15.

In case of keeping module is in the circumstance of  $0\text{ }^{\circ}\text{C}$ , it should be placed in the circumstance of above  $15\text{ }^{\circ}\text{C}$  for 2 hours.

In case of keeping module is in the circumstance of below  $-20\text{ }^{\circ}\text{C}$ , it should be placed in the circumstance of above  $15\text{ }^{\circ}\text{C}$  for 3 hours.

### [Caution]

When still image is displayed for a period of 20 minutes or longer (Especially where W/B scale is strong. Digital pattern 13ch and/or Cross hatch pattern 09ch), there can some afterimage in the black level area.

## 3. Automatic Adjustment

### 3.1. MAC address D/L, CI+ key D/L, Widevine key D/L, ESN D/L, HDCP20 D/L

Connect: USB port

Communication Prot connection

- Com 1,2,3,4 and 115200(Baudrate)

Mode check: Online Only

- Check the test process

: DETECT → ESN → Widevine → CI → HDCP20

\* DTCP key is downloaded only for EU suffix models, for example, 47LA660S-ZA.KEUYLJG

- Play: Press Enter key
- Result: Ready, Test, OK or NG
- Printer Out (MAC Address Label)

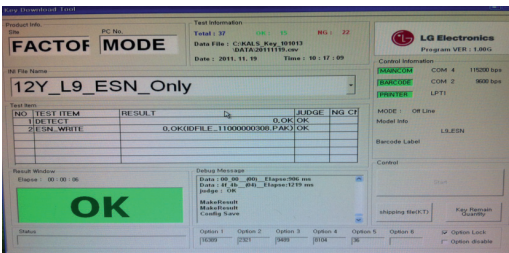

## 3.2. LAN Inspection

### 3.2.1. Equipment & Condition

- Each other connection to LAN Port of IP Hub and Jig

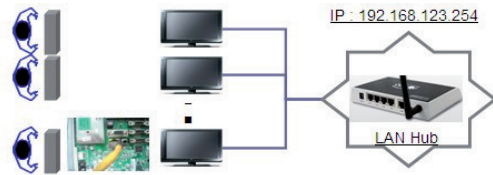

### 3.2.2. LAN inspection solution

- LAN Port connection with PCB
- Network setting at MENU Mode of TV
- Setting automatic IP
- Setting state confirmation
- If automatic setting is finished, you confirm IP and MAC Address.

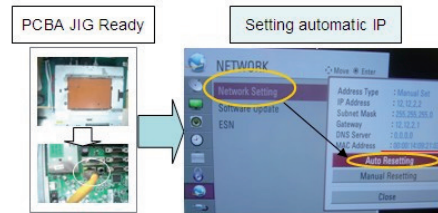

### 3.2.3. WIDEVINE key Inspection

- Confirm key input data at the "IN START" MENU Mode.

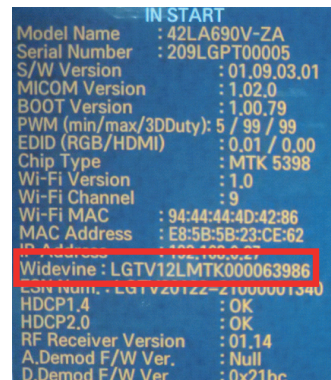

### 3.3. LAN PORT INSPECTION(PING TEST)

Connect SET → LAN port == PC → LAN Port

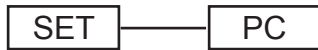

#### 3.3.1. Equipment setting

- Play the LAN Port Test PROGRAM.
- Input IP set up for an inspection to Test Program.  
\*IP Number : 12.12.2.2

#### 3.3.2. LAN PORT inspection(PING TEST)

- Play the LAN Port Test Program.
- Connect each other LAN Port Jack.
- Play Test (F9) button and confirm OK Message.
- Remove LAN cable.

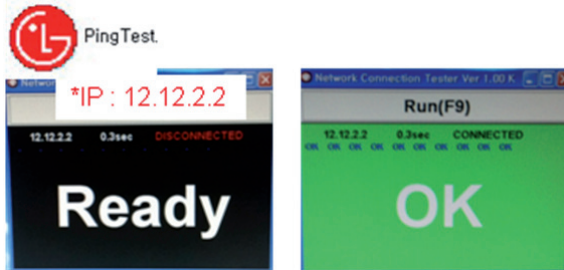

### 3.4. Model name & Serial number Download

#### 3.4.1. Model name & Serial number D/L

- Press "P-ONLY" key of service remote control.  
(Baud rate : 115200 bps)
- Connect RS-232C Signal to USB Cable to USB.
- Write Serial number by use USB port.
- Must check the serial number at Instart menu.

#### 3.4.2. Method & notice

- Serial number D/L is using of scan equipment.
- Setting of scan equipment operated by Manufacturing Technology Group.
- Serial number D/L must be conformed when it is produced in production line, because serial number D/L is mandatory by D-book 4.0.

#### \* Manual Download (Model Name and Serial Number)

If the TV set is downloaded by OTA or service man, sometimes model name or serial number is initialized.(Not always)  
It is impossible to download by bar code scan, so It need Manual download.

- Press the "Instart" key of Adjustment remote control.
- Go to the menu "7.Model Number D/L" like below photo.
- Input the Factory model name(ex 47LB650V-ZA) or Serial number like photo.

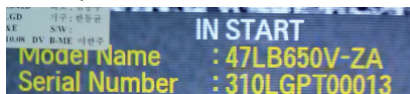

- Check the model name Instart menu. → Factory name displayed. (ex 47LB650V-ZA)
- Check the Diagnostics.(DTV country only) → Buyer model displayed. (ex 47LB650V-ZA)

### 3.5. CI+ Key checking method

- Check the Section 3.1

Check whether the key was downloaded or not at 'In Start' menu. (Refer to below).

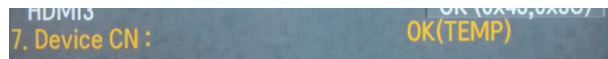

=> Check the Download to CI+ Key value in LGset.

#### 3.5.1. Check the method of CI+ Key value

- Check the method on Instart menu
- Check the method of RS232C Command
  - Into the main ass'y mode(RS232: aa 00 00)

CMD 1	CMD 2	Data 0	
A	A	0	0

- Check the key download for transmitted command (RS232: ci 00 10)

CMD 1	CMD 2	Data 0	
C	I	1	0

- Result value

- Normally status for download : OKx
- Abnormally status for download : NGx

#### 3.5.2. Check the method of CI+ key value(RS232)

- Into the main ass'y mode(RS232: aa 00 00)

CMD 1	CMD 2	Data 0	
A	A	0	0

- Check the method of CI+ key by command (RS232: ci 00 20)

CMD 1	CMD 2	Data 0	
C	I	2	0

- Result value

i 01 OK 1d1852d21c1ed5dcx

↳ CI+ Key Value

### 3.6. WIFI MAC ADDRESS CHECK

- Using RS232 Command

	H-freq(kHz)	V-freq.(Hz)
Transmission	[A][I][ ][Set ID][ ][20][Cr]	[O][K][X] or [NG]

- Check the menu on in-start

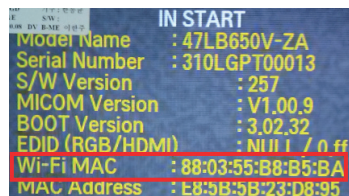



## 4. Manual Adjustment

### 4.1. EDID(The Extended Display Identification Data)/DDC(Display Data Channel) download

#### 4.1.1. Overview

It is a VESA regulation. A PC or a MNT will display an optimal resolution through information sharing without any necessity of user input. It is a realization of "Plug and Play".

#### 4.1.2. Equipment

- Since embedded EDID data is used, EDID download JIG, HDMI cable and D-sub cable are not need.
- Adjustment remote control

#### 4.1.3. Download method

- (1) Press "ADJ" key on the Adjustment remote control, then select "12.EDID D/L", By pressing "Enter" key, enter EDID D/L menu.



- (2) Select "Start" button by pressing "Enter" key, HDMI1/ HDMI2/ HDMI3/ HDMI4 are writing and display OK or NG.

#### 4.1.4. EDID DATA

- Reference
- HDMI1 ~ HDMI3
- In the data of EDID, bellows may be different by Input mode.

	0	1	2	3	4	5	6	7	8	9	A	B	C	D	E	F
0x00	00	FF	FF	FF	FF	FF	FF	00	1E	6D	a)		b)			
0x01	c)		01	03	80	A0	5A	78	0A	EE	91	A3	54	4C	99	26
0x02	0F	50	54	A1	8	00	31	40	45	40	61	40	71	40	81	80
0x03	01	01	01	01	01	02	3A	80	18	71	38	2D	40	58	2C	
0x04	45	00	40	84	63	00	00	1E	66	21	50	B0	51	00	1B	30
0x05	40	70	36	00	40	84	63	00	00	1E	00	00	00	FD	00	3A
0x06	3E	1E	53	10	00	0A	20	20	20	20	20	20	d)			
0x07															01	e)
0x00	02	03	3A	F1	4E	10	9F	04	13	05	14	03	02	12	20	21
0x01	22	15	01	29	3D	06	C0	15	07	50	f)					
0x02	g)															
0x03	h)		10	28	10	E3	05	03	01	02	3A	80	18	71	38	
0x04	2D	40	58	2C	45	00	40	84	63	00	00	1E	01	1D	80	18
0x05	71	1C	16	20	58	2C	25	00	40	84	63	00	00	9E	01	1D
0x06	00	72	51	D0	1E	20	6E	28	55	00	40	84	63	00	00	1E
0x07	00	00	00	00	00	00	00	00	00	00	00	00	00	00	00	e)2

- a) Product ID
- b) Serial No: Controlled on production line.
- c) Month, Year: Controlled on production line:  
ex) Monthly : '01' → '01', Year : '2014' → '18'
- d) Model Name(Hex): LGTV
- e) Checksum(LG TV): Changeable by total EDID data.
- f) Vendor Specific(HDMI)

(1) EDID for Non3D Model(UB82)

# HDMI 1(C/S: E7, 2D)

EDID Block 0, Bytes 0-127 [00H-7FH]

	0	1	2	3	4	5	6	7	8	9	A	B	C	D	E	F
0	00	FF	FF	FF	FF	FF	FF	00	1E	6D	01	00	01	01	01	01
10	01	18	01	03	80	A0	5A	78	0A	EE	91	A3	54	4C	99	26
20	0F	50	54	A1	08	00	31	40	45	40	61	40	71	40	81	80
30	01	01	01	01	01	01	02	3A	80	18	71	38	2D	40	58	2C
40	45	00	40	84	63	00	00	1E	66	21	50	B0	51	00	1B	30
50	40	70	36	00	40	84	63	00	00	1E	00	00	00	FD	00	3A
60	3E	1E	53	10	00	0A	20	20	20	20	20	20	20	00	00	00
70	00	4C	47	20	54	56	0A	20	20	20	20	20	20	20	01	E7

EDID Block 1, Bytes 128-255 [80H-FFH]

	0	1	2	3	4	5	6	7	8	9	A	B	C	D	E	F
80	02	03	3C	F1	54	10	9F	04	13	05	14	03	02	12	20	21
90	22	15	01	5D	5E	5F	62	63	64	29	3D	06	C0	15	07	50
A0	09	57	07	6E	03	0C	00	10	00	B8	3C	20	00	80	01	02
B0	03	04	E3	05	03	01	E5	0E	60	61	65	66	01	1D	80	18
C0	71	1C	16	20	58	2C	25	00	40	84	63	00	00	9E	01	1D
D0	00	72	51	D0	1E	20	6E	28	55	00	40	84	63	00	00	1E
E0	00	00	00	00	00	00	00	00	00	00	00	00	00	00	00	00
F0	00	00	00	00	00	00	00	00	00	00	00	00	00	00	00	2D

# HDMI2 (C/S: E7, 1D)

EDID Block 0, Bytes 0-127 [00H-7FH]

	0	1	2	3	4	5	6	7	8	9	A	B	C	D	E	F
0	00	FF	FF	FF	FF	FF	FF	00	1E	6D	01	00	01	01	01	01
10	01	18	01	03	80	A0	5A	78	0A	EE	91	A3	54	4C	99	26
20	0F	50	54	A1	08	00	31	40	45	40	61	40	71	40	81	80
30	01	01	01	01	01	01	02	3A	80	18	71	38	2D	40	58	2C
40	45	00	40	84	63	00	00	1E	66	21	50	B0	51	00	1B	30
50	40	70	36	00	40	84	63	00	00	1E	00	00	00	FD	00	3A
60	3E	1E	53	10	00	0A	20	20	20	20	20	20	20	00	00	00
70	00	4C	47	20	54	56	0A	20	20	20	20	20	20	20	01	E7

EDID Block 1, Bytes 128-255 [80H-FFH]

	0	1	2	3	4	5	6	7	8	9	A	B	C	D	E	F
80	02	03	3C	F1	54	10	9F	04	13	05	14	03	02	12	20	21
90	22	15	01	5D	5E	5F	62	63	64	29	3D	06	C0	15	07	50
A0	09	57	07	6E	03	0C	00	20	00	B8	3C	20	00	80	01	02
B0	03	04	E3	05	03	01	E5	0E	60	61	65	66	01	1D	80	18
C0	71	1C	16	20	58	2C	25	00	40	84	63	00	00	9E	01	1D
D0	00	72	51	D0	1E	20	6E	28	55	00	40	84	63	00	00	1E
E0	00	00	00	00	00	00	00	00	00	00	00	00	00	00	00	00
F0	00	00	00	00	00	00	00	00	00	00	00	00	00	00	00	1D

# HDMI3 (C/S: E7, DD)

EDID Block 0, Bytes 0-127 [00H-7FH]

	0	1	2	3	4	5	6	7	8	9	A	B	C	D	E	F
0	00	FF	FF	FF	FF	FF	FF	00	1E	6D	01	00	01	01	01	01
10	01	18	01	03	80	A0	5A	78	0A	EE	91	A3	54	4C	99	26
20	0F	50	54	A1	08	00	31	40	45	40	61	40	71	40	81	80
30	01	01	01	01	01	01	02	3A	80	18	71	38	2D	40	58	2C
40	45	00	40	84	63	00	00	1E	66	21	50	B0	51	00	1B	30
50	40	70	36	00	40	84	63	00	00	1E	00	00	00	FD	00	3A
60	3E	1E	53	10	00	0A	20	20	20	20	20	20	20	00	00	00
70	00	4C	47	20	54	56	0A	20	20	20	20	20	20	20	01	E7

EDID Block 1, Bytes 128-255 [80H-FFH]

0	1	2	3	4	5	6	7	8	9	A	B	C	D	E	F	
80	02	03	3C	F1	54	10	9F	04	13	05	14	03	02	12	20	21
90	22	15	01	5D	5E	5F	62	63	64	29	3D	06	C0	15	07	50
A0	09	57	07	6E	03	0C	00	30	00	B8	3C	20	00	80	01	02
B0	03	04	E3	05	03	01	E5	0E	60	61	65	66	01	1D	80	18
C0	71	1C	16	20	58	2C	25	00	40	84	63	00	00	9E	01	1D
D0	00	72	51	D0	1E	20	6E	28	55	00	40	84	63	00	00	1E
E0	00	00	00	00	00	00	00	00	00	00	00	00	00	00	00	00
F0	00	00	00	00	00	00	00	00	00	00	00	00	00	00	00	0D

\* Checksum(HDMI1/2/3)

Input	FFh (Checksum)	
HDMI1	E7	2D
HDMI2	E7	1D
HDMI3	E7	0D

## 4.2. White Balance Adjustment

### 4.2.1. Overview

- W/B adj. Objective & How-it-works
  - Objective: To reduce each Panel's W/B deviation
  - How-it-works : When R/G/B gain in the OSD is at 192, it means the panel is at its Full Dynamic Range. In order to prevent saturation of Full Dynamic range and data, one of R/G/B is fixed at 192, and the other two is lowered to find the desired value.
  - Adjustment condition : normal temperature
    - Surrounding Temperature : 25 °C ± 5 °C
    - Warm-up time: About 5 Min
    - Surrounding Humidity : 20 % ~ 80 %

### 4.2.2. Equipment

- Color Analyzer: CA-210 (LED Module : CH 14)
  - Adjustment Computer(During auto adj., RS-232C protocol is needed)
  - Adjustment Remote control
  - Video Signal Generator MSPG-925F 720p/216-Gray (Model: 204, Pattern: 49)
    - Only when internal pattern is not available
- Color Analyzer Matrix should be calibrated using CS-100.

### 4.2.3. Equipment connection MAP

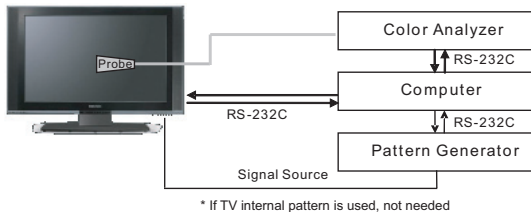

## 4.2.4. Adj. Command (Protocol)

<Command Format>

START	6E	A	50	A	LEN	A	03	A	CMD	A	00	A	VAL	A	CS	STOP
-------	----	---	----	---	-----	---	----	---	-----	---	----	---	-----	---	----	------

- LEN: Number of Data Byte to be sent
  - CMD: Command
  - VAL: FOS Data value
  - CS: Checksum of sent data
  - A: Acknowledge
- Ex) [Send: JA\_00\_DD] / [Ack: A\_00\_okDDX]

▪ RS-232C Command used during auto-adjustment.

RS-232C COMMAND [CMD ID DATA]			Explanation
wb	00	00	Begin White Balance adjustment
wb	00	10	Gain adjustment(internal white pattern)
wb	00	1f	Gain adjustment completed
wb	00	20	Offset adjustment(internal white pattern)
wb	00	2f	Offset adjustment completed
wb	00	ff	End White Balance adjustment (internal pattern disappears)

- Ex) wb 00 00 -> Begin white balance auto-adj.  
 wb 00 10 -> Gain adj.  
 ja 00 ff -> Adj. data  
 jb 00 c0  
 ...  
 ...  
 wb 00 1f -> Gain adj. completed  
 \*(wb 00 20(Start), wb 00 2f(end)) -> Off-set adj.  
 wb 00 ff -> End white balance auto-adj.

▪ Adj. Map

	Adj. item	Command (lower case ASCII)		Data Range (Hex.)		Default (Decimal)
		CMD1	CMD2	MIN	MAX	
Cool	R Gain	j	g	00	C0	
	G Gain	j	h	00	C0	
	B Gain	j	i	00	C0	
	R Cut					
	G Cut					
	B Cut					
Medium	R Gain	j	a	00	C0	
	G Gain	j	b	00	C0	
	B Gain	j	c	00	C0	
	R Cut					
	G Cut					
	B Cut					
Warm	R Gain	j	d	00	C0	
	G Gain	j	e	00	C0	
	B Gain	j	f	00	C0	
	R Cut					
	G Cut					
	B Cut					

#### 4.2.5. Adj. method

##### (1) Auto adj. method

- 1) Set TV in adj. mode using POWER ON key.
- 2) Zero calibrate probe then place it on the center of the Display.
- 3) Connect Cable.(RS-232C to USB)
- 4) Select mode in adj. Program and begin adj.
- 5) When adj. is complete (OK Sign), check adj. status pre mode. (Warm, Medium, Cool)
- 6) Remove probe and RS-232C cable to complete adj.

- W/B Adj. must begin as start command "wb 00 00" , and finish as end command "wb 00 ff", and Adj. offset if need.

##### (2) Manual adjustment. method

- 1) Set TV in Adj. mode using POWER ON.
- 2) Zero Calibrate the probe of Color Analyzer, then place it on the center of LCD module within 10 cm of the surface.
- 3) Press ADJ key → EZ adjust using adj. R/C → 7. White-Balance then press the cursor to the right(key ►).  
(When right key(►) is pressed 216 Gray internal pattern will be displayed)
- 4) One of R Gain / G Gain / B Gain should be fixed at 192, and the rest will be lowered to meet the desired value.
- 5) Adjustment is performed in COOL, MEDIUM, WARM 3 modes of color temperature.

##### \*\* G-fix adjustment

Adjust modes (Cool), Fix the G gain to 172 (default data) and change the others (G/B Gain).

Adjust two modes(Medium / Warm), Fix the one of R/G/B gain to 192 (default data) and decrease the others.

- If internal pattern is not available, use RF input. In EZ Adj. menu 7.White Balance, you can select one of 2 Test-pattern: ON, OFF. Default is inner(ON). By selecting OFF, you can adjust using RF signal in 216 Gray pattern.

##### ▪ Adjustment condition and cautionary items

- 1) Lighting condition in surrounding area  
Surrounding lighting should be lower 10 lux. Try to isolate adj. area into dark surrounding.
- 2) Probe location  
: Color Analyzer(CA-210) probe should be within 10 cm and perpendicular of the module surface (80° ~ 100°)
- 3) Aging time  
- After Aging Start, Keep the Power ON status during 5 Minutes.  
- In case of LCD, Back-light on should be checked using no signal or Full-white pattern.

#### 4.2.6. Reference (White balance Adj. coordinate and color temperature)

- Luminance : 206 Gray
- Standard color coordinate and temperature using CS-1000 (over 26 inch)

Mode	Coordinate		Temp	Δuv
	x	y		
Cool	0.271	0.270	13000 K	0.0000
Medium	0.286	0.289	9300 K	0.0000
Warm	0.313	0.329	6500 K	0.0000

- Standard color coordinate and temperature using CA-210(CH 14)

Mode	Coordinate		Temp	Δuv
	x	y		
Cool	0.271 ± 0.002	0.270 ± 0.002	13000 K	0.0000
Medium	0.286 ± 0.003	0.289 ± 0.003	9300 K	0.0000
Warm	0.313 ± 0.002	0.329 ± 0.002	6500 K	0.0000

#### 4.2.7. EDGE & IOL LED White balance table

- EDGE LED module change color coordinate because of aging time.
- Apply under the color coordinate table, for compensated aging time.
- (Normal line) Edge & ALEF LED White balance table  
- gumi(Mar. ~ Dec.) & Global  
Model : (normal line) LGD, CMI

NC	Aging time (Min)	Cool		Medium		Warm	
		x	y	x	y	x	y
4.0		271	270	286	289	313	329
1	0-2	282	289	297	308	324	348
2	3-5	281	287	296	306	323	346
3	6-9	279	284	294	303	321	343
4	10-19	277	280	292	299	319	339
5	20-35	275	277	290	296	317	336
6	36-49	274	274	289	293	316	333
7	50-79	273	272	288	291	315	331
8	80-119	272	271	287	290	314	330
9	Over 120	271	270	286	289	313	329

- gumi Winter table(Jan., Feb.)- Gumi producing model use only  
Model : (normal line) LGD, CMI

NC	Agingtime (Min)	Cool		Medium		Warm	
		x	y	x	y	x	y
4.0		271	270	285	293	313	329
1	0-5	280	285	294	308	319	340
2	6-10	276	280	290	303	315	335
3	11-20	272	275	286	298	311	330
4	21-30	269	272	283	295	308	327
5	31-40	267	268	281	291	306	323
6	41-50	266	265	280	288	305	320
7	51-80	265	263	279	286	304	318
8	81-119	264	261	278	284	303	316
9	Over 120	264	260	278	283	303	315

- (Aging Chamber) Edge & ALEF  
Model : (aging chamber)LGD, CMI

NC 4.0	Aging time (Min)	Cool		Medium		Warm	
		x	y	x	y	x	y
1	0-5	271	270	285	293	313	329
2	6-10	280	285	294	308	319	340
3	11-20	276	280	290	303	315	335
4	21-30	272	275	286	298	311	330
5	31-40	269	272	283	295	308	327
6	41-50	267	268	281	291	306	323
7	51-80	266	265	280	288	305	320
8	81-119	265	263	279	286	304	318
9	Over 120	264	261	278	284	303	316
		264	260	278	283	303	315

### 4.3. Local Dimming Function Check

- (1) Turn on TV.
- (2) At the Local Dimming mode, module Edge Backlight moving right to left Back light of IOP module moving.
- (3) Confirm the Local Dimming mode.
- (4) Press "exit" Key.



Local Dimming Demo

### 4.4. Magic Motion Remote control test

- Equipment : RF Remote control for test, IR-KEY-Code Remote control for test
- You must confirm the battery power of RF-Remote control before test(recommend that change the battery per every lot)
- Sequence (test)
  - 1) If you select the 'start key(OK)' on the Adjustment remote control, you can pairing with the TV SET.
  - 2) You can check the cursor on the TV Screen, when select the "OK" key on the Adjustment remote control.
  - 3) You must remove the pairing with the TV Set by select 'Mute + OK Key' on the Adjustment remote control.

### 4.5. 3D function test

- (Pattern Generator MSHG-600, MSPG-6100[Support HDMI1.4])
- \* HDMI mode NO. 872 , pattern No.83
- (1) Please input 3D test pattern like below.



- (2) When 3D OSD appear automatically, then select green key.



- (3) Don't wear a 3D Glasses, Check the picture like below.



### 4.6. Option selection per country

#### 4.6.1. Overview

- Option selection is only done for models in AJ/JA/IL

#### 4.6.2.Method

- (1) Press "ADJ" key on the Adjustment remote control, then select Country Group Menu.
- (2) Depending on destination, select Country Group Code or Country Group then on the lower Country option, select US, CA, MX. Selection is done using +, - or ►◀ KEY.

## 4.7. HDMI ARC Function Inspection

- (1) Test equipment
  - Optic Receiver Speaker
  - MSHG-600 (SW: 1220 ↑)
  - HDMI Cable (for 1.4 version)
- (2) Test method
  - 1) Insert the HDMI Cable to the HDMI ARC port from the master equipment. (HDMI2)

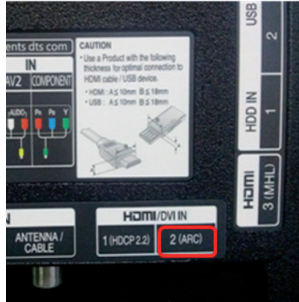

- 2) Check the sound from the TV Set.



- 3) Check the Sound from the Speaker or using AV & Optic TEST program (It's connected to MSHG-600)

## 4.8. Tool Option selection

- Method : Press "ADJ" key on the Adjustment remote control, then select Tool option.

## 4.9. Ship-out mode check (In-stop)

- After final inspection, press In-Stop key of the Adjustment remote control and check that the unit goes to Stand-by mode.

## 5. GND and Internal Pressure check

### 5.1. Method

- (1) GND & Internal Pressure auto-check preparation
    - Check that Power Cord is fully inserted to the SET. (If loose, re-insert)
  - (2) Perform GND & Internal Pressure auto-check
    - Unit fully inserted Power cord, Antenna cable and A/V arrive to the auto-check process.
    - Connect D-terminal to AV JACK TESTER
    - Auto CONTROLLER(GWS103-4) ON
    - Perform GND TEST
    - If NG, Buzzer will sound to inform the operator.
    - If OK, changeover to I/P check automatically. (Remove CORD, A/V form AV JACK BOX.)
    - Perform I/P test
    - If NG, Buzzer will sound to inform the operator.
- If OK, Good lamp will lit up and the stopper will allow the pallet to move on to next process.

### 5.2. Checkpoint

- TEST voltage
  - GND: 1.5 KV / min at 100 mA
  - SIGNAL: 3 KV / min at 100 mA
- TEST time: 1 second
- TEST POINT
  - GND TEST = POWER CORD GND & SIGNAL CABLE METAL GND
  - Internal Pressure TEST = POWER CORD GND & LIVE & NEUTRAL
- LEAKAGE CURRENT: At 0.5 mArms

## 6. Audio

No.	Item	Min	Typ	Max	Unit	
1	Audio practical max Output, L/R (Distortion=10% max Output)		10	12	W	EQ Off AVL Off Clear Voice Off
			8.10	10.8	Vrms	
2	Speaker (8 Ω Impedance)		10	12	W	EQ On AVL On Clear Voice On

Measurement condition:

- (1) RF input: Mono, 1 KHz sine wave signal, 100 % Modulation
- (2) CVBS, Component: 1 KHz sine wave signal 0.5 Vrms

## 7. USB S/W Download(Service only)

- (1) Put the USB Stick to the USB socket.
- (2) Automatically detecting update file in USB Stick.
  - If your downloaded program version in USB Stick is Low, it didn't work. But your downloaded version is High, USB data is automatically detecting.(Download Version High & Power only mode, Set is automatically Download)
- (3) Show the message "Copying files from memory".

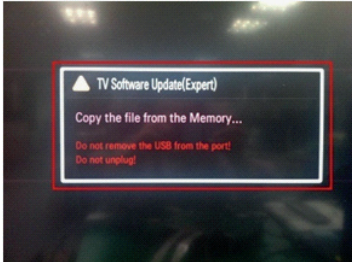

- (4) Updating is starting.
- (5) Updating Completed, The TV will restart automatically.

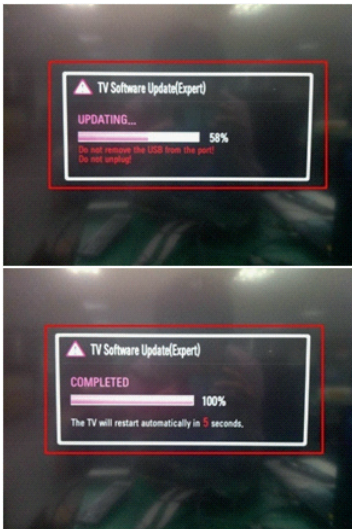

- (6) If your TV is turned on, check your updated version and Tool option. (explain the Tool option, next stage)
    - \* If downloading version is more high than your TV have, TV can lost all channel data. In this case, you have to channel recover. if all channel data is cleared, you didn't have a DTV/ATV test on production line.
- \* After downloading, have to adjust TOOL OPTION again.
- 1) Push "IN-START" key in service remote control.
  - 2) Select "Tool Option 1" and push "OK" key.
  - 3) Punch in the number. (Each model has their number.)

# BLOCK DIAGRAM

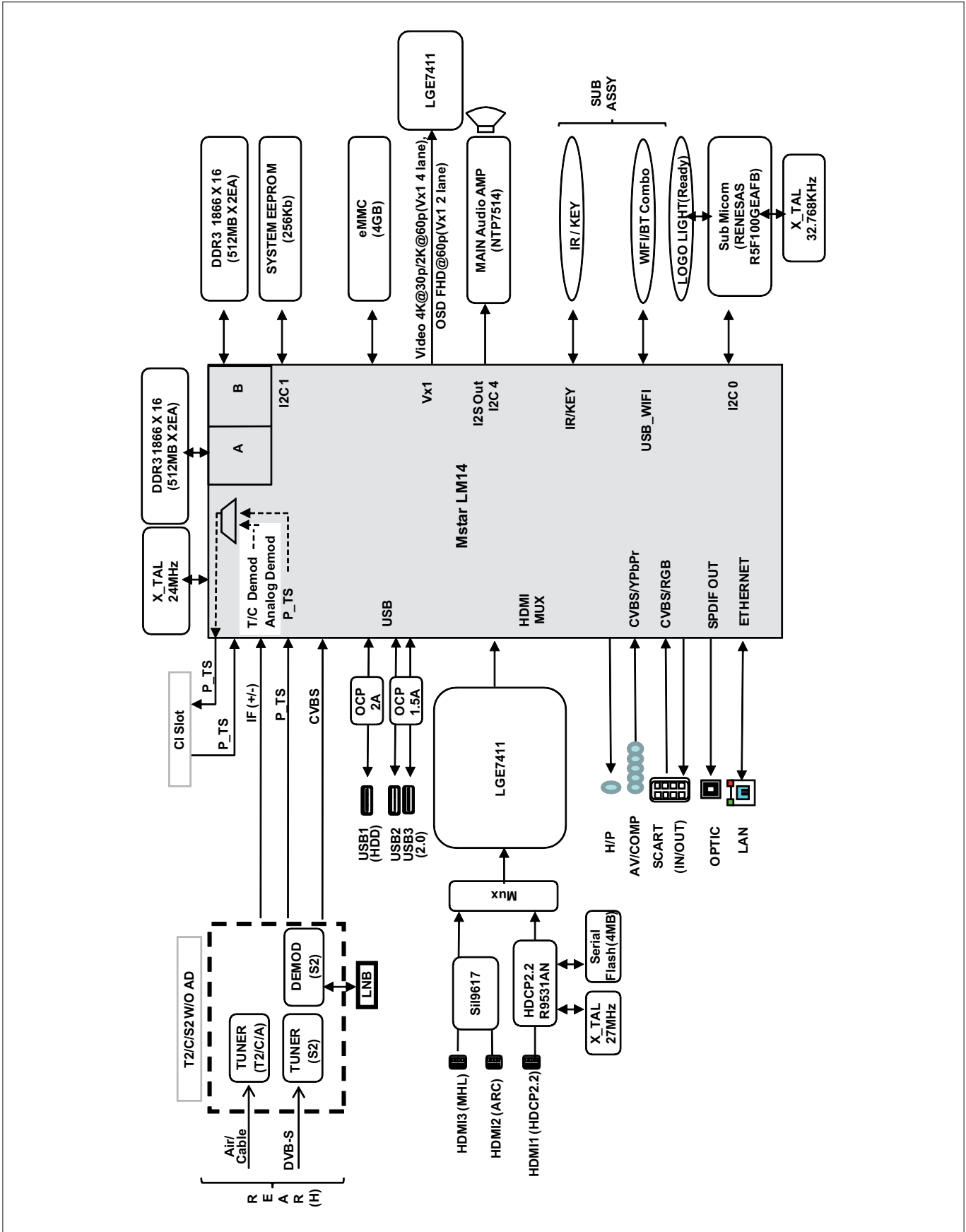

# EXPLODED VIEW

## IMPORTANT SAFETY NOTICE

Many electrical and mechanical parts in this chassis have special safety-related characteristics. These parts are identified by  $\Delta$  in the Schematic Diagram and EXPLODED VIEW. It is essential that these special safety parts should be replaced with the same components as recommended in this manual to prevent X-RADIATION, Shock, Fire, or other Hazards. Do not modify the original design without permission of manufacturer.

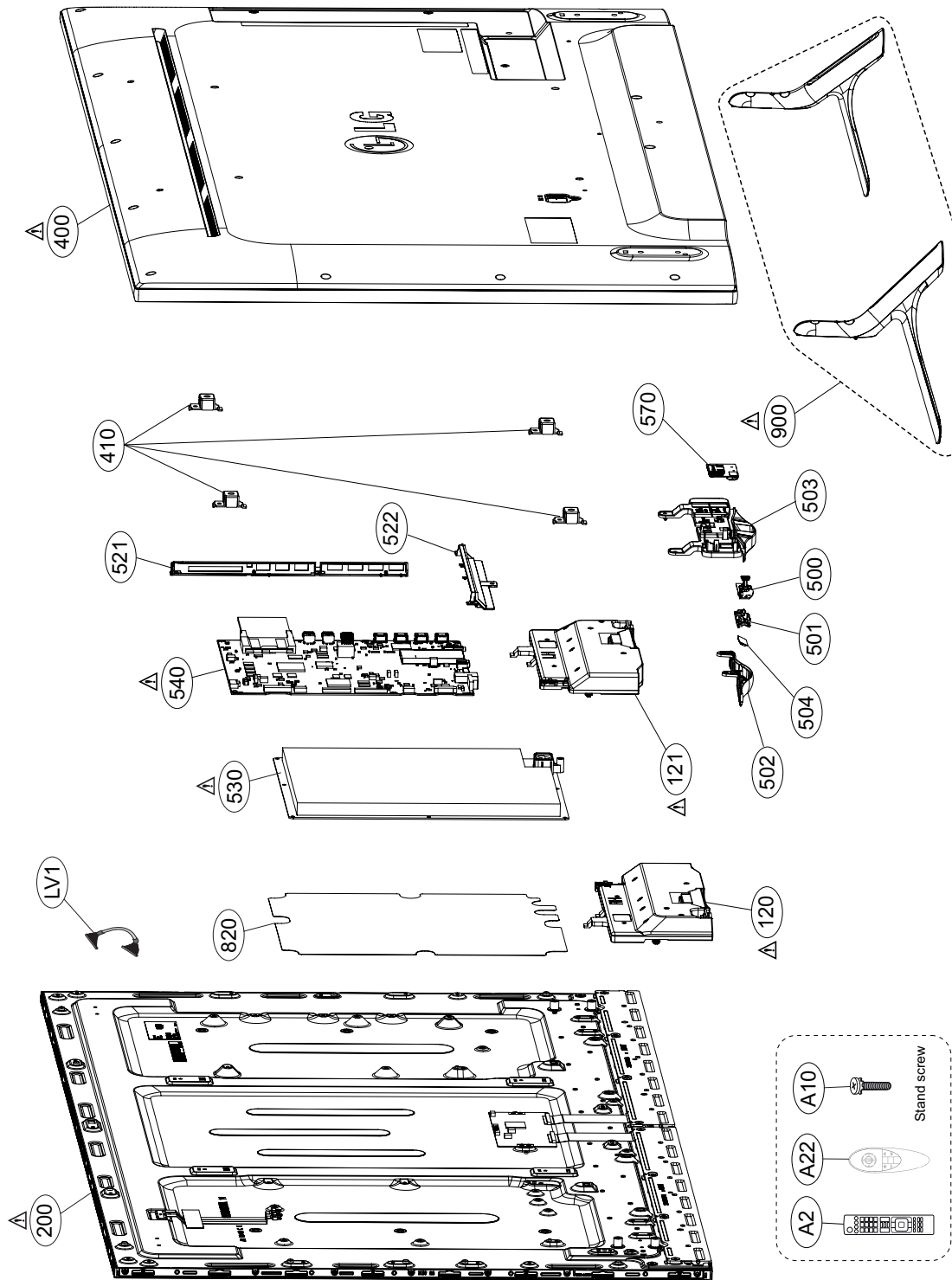



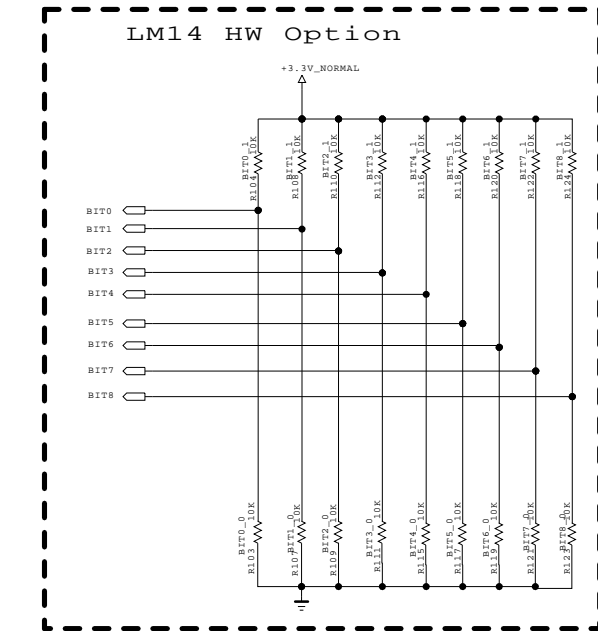
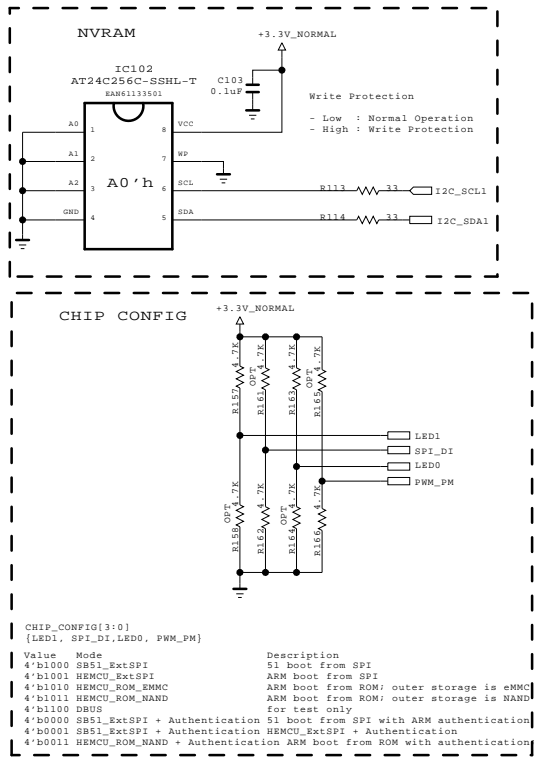

BIT(4)	Low	High
BIT4	MODEL	LM14+URSA9
BIT5	Reserved	LM14 ONLY
BIT6	Reserved	
BIT7	Reserved	
BIT8	Reserved	

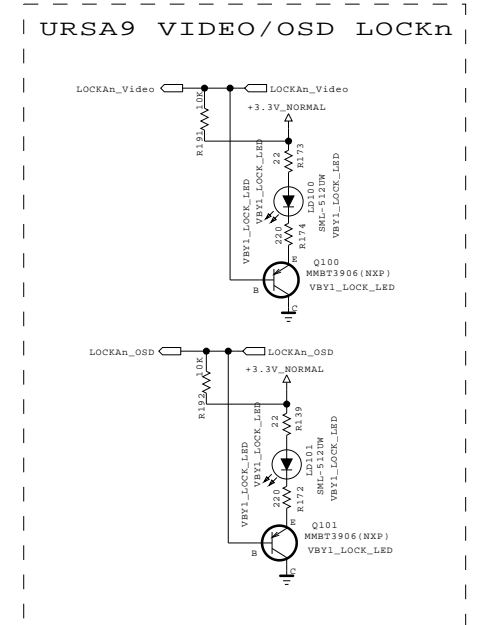
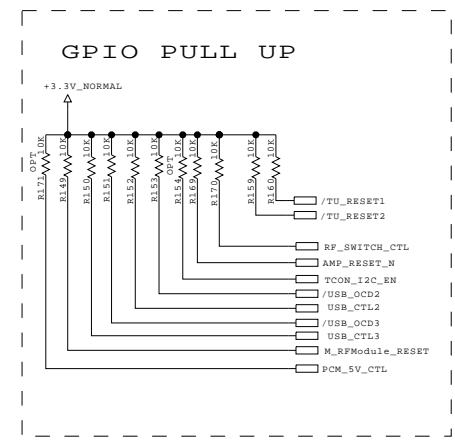
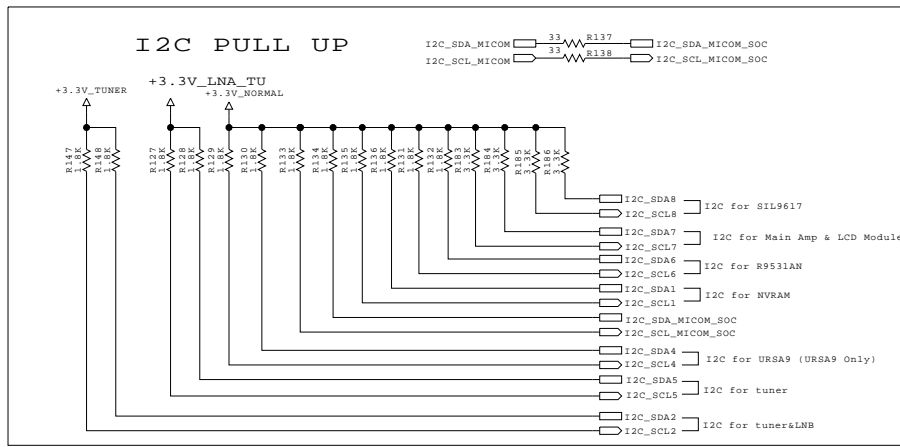
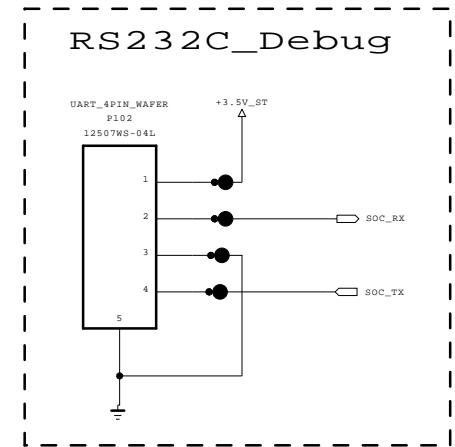
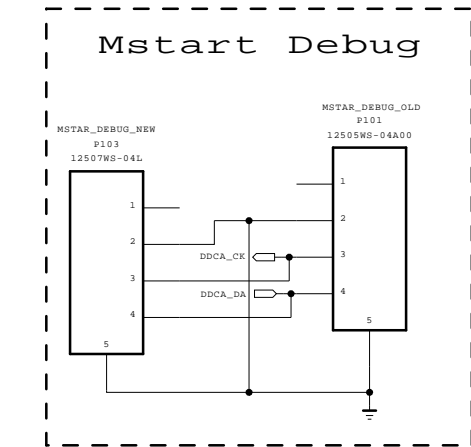

THE SYMBOL MARK OF THIS SCHEMATIC DIAGRAM INCORPORATES SPECIAL FEATURES IMPORTANT FOR PROTECTION FROM X-RADIATION. FIRE AND ELECTRICAL SHOCK HAZARDS, WHEN SERVICING IF IS ESSENTIAL THAT ONLY MANUFACTURERS SPECIFIED PARTS BE USED FOR THE CRITICAL COMPONENTS IN THE SYMBOL MARK OF THE SCHEMATIC.

**SECRET**  
LGElectronics



<b>MODEL</b>	UB83	<b>DATE</b>	2013-10-28
<b>BLOCK</b>	LM14 SYSTEM	<b>SHEET</b>	01

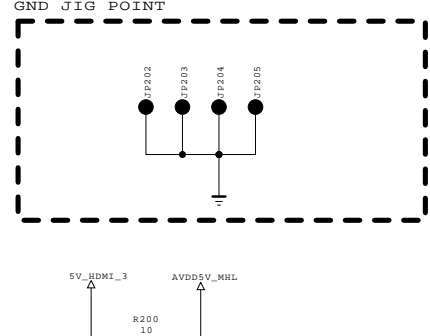
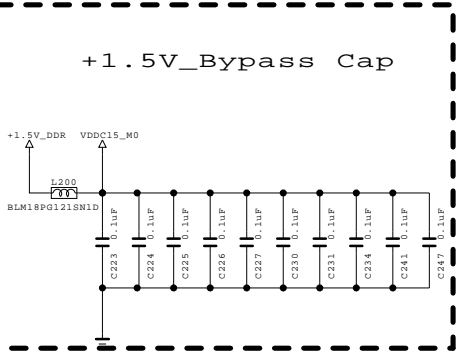
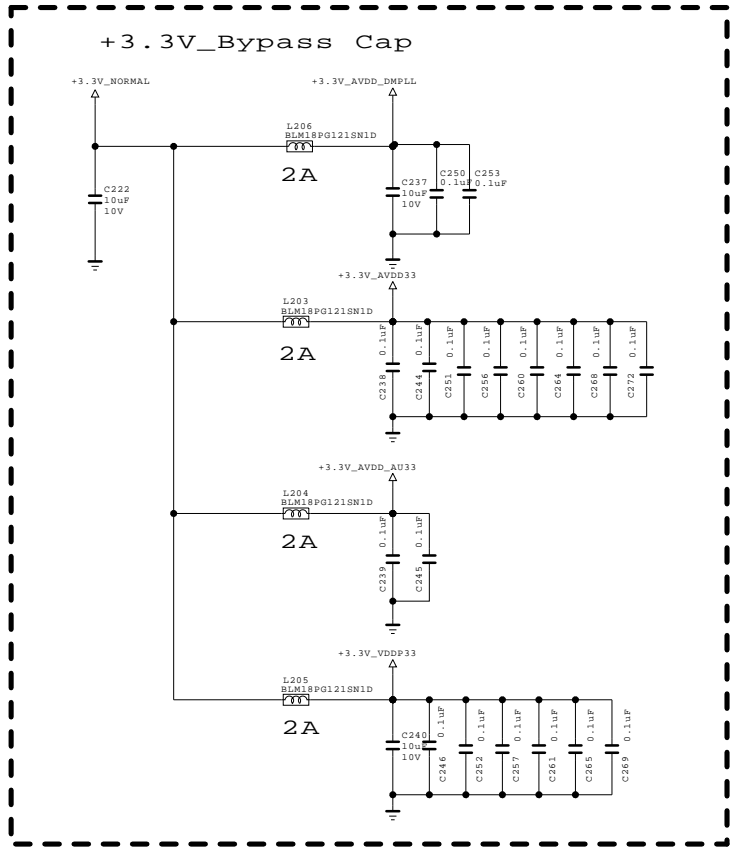
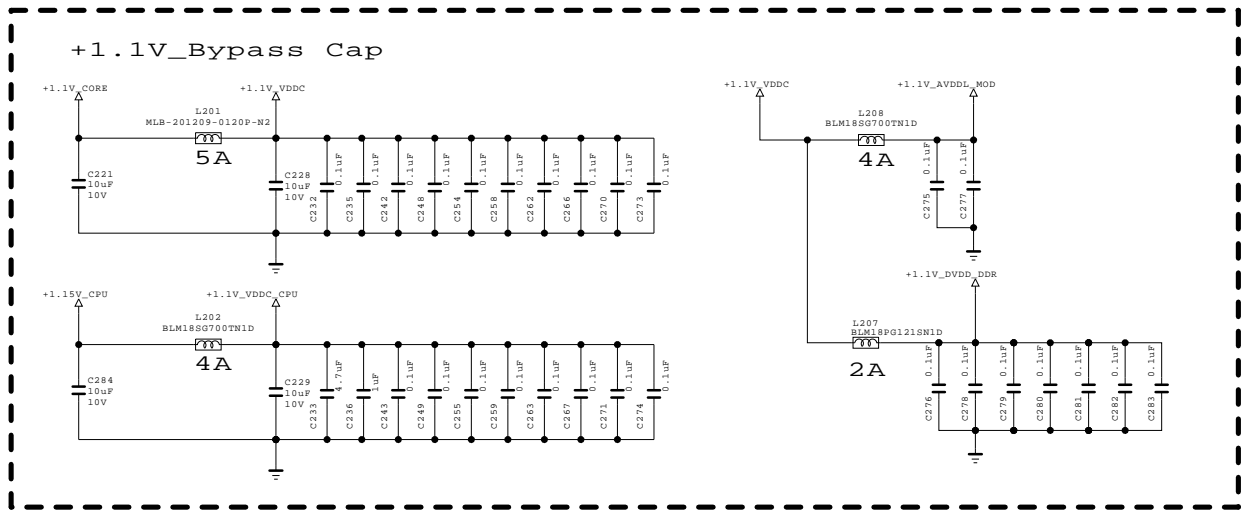
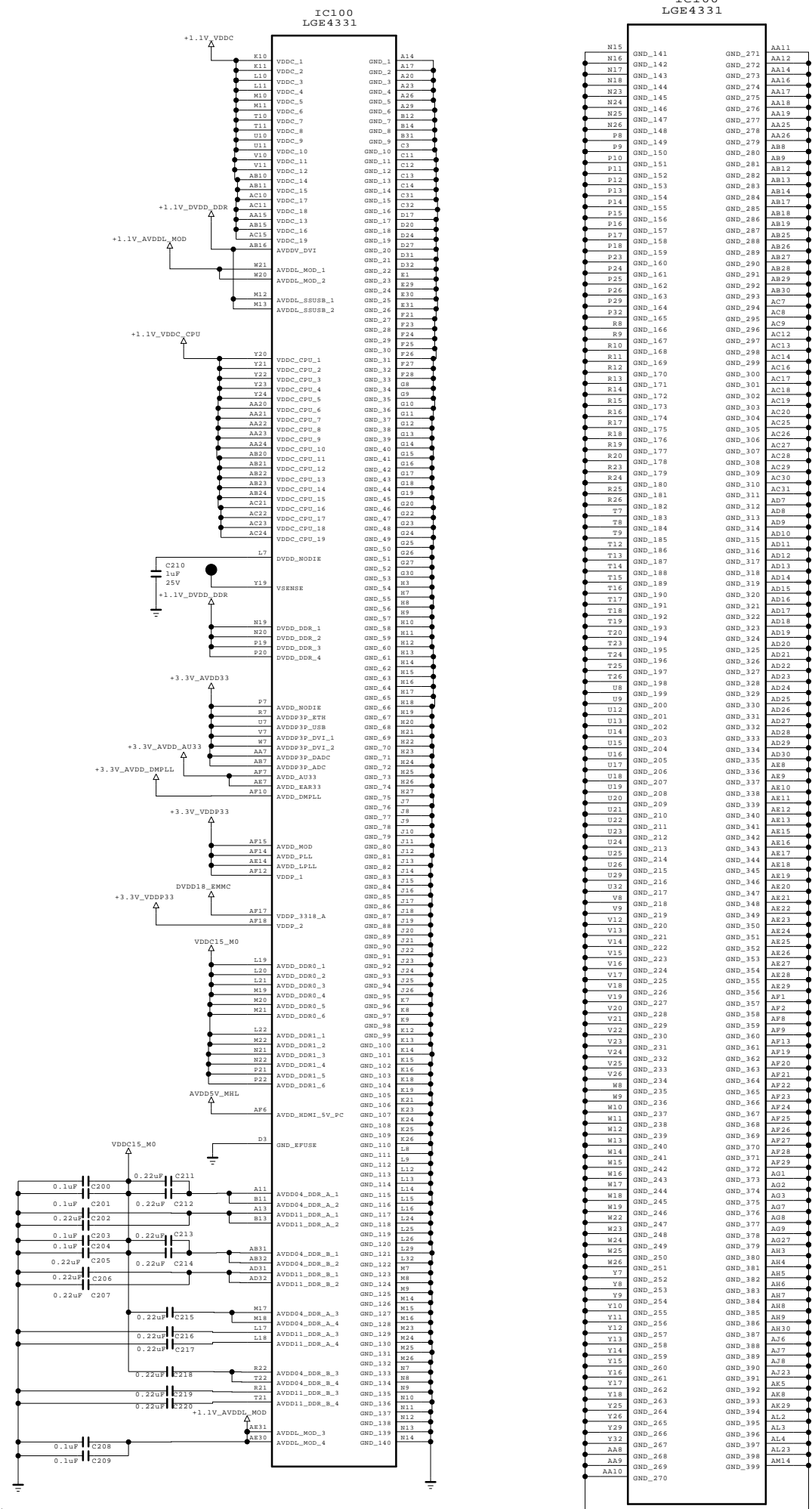

THE  $\Delta$  SYMBOL MARK OF THIS SCHEMATIC DIAGRAM INCORPORATES SPECIAL FEATURES IMPORTANT FOR PROTECTION FROM X-RADIATION, FIRE AND ELECTRICAL SHOCK HAZARDS, WHEN SERVICING IF IS ESSENTIAL THAT ONLY MANUFACTURERS SPECIFIED PARTS BE USED FOR THE CRITICAL COMPONENTS IN THE  $\Delta$  SYMBOL MARK OF THE SCHEMATIC.

SECRET  
 LGElectronics



MODEL	UB83	DATE	2013-10-28
BLOCK	LM14 POWER	SHEET	02

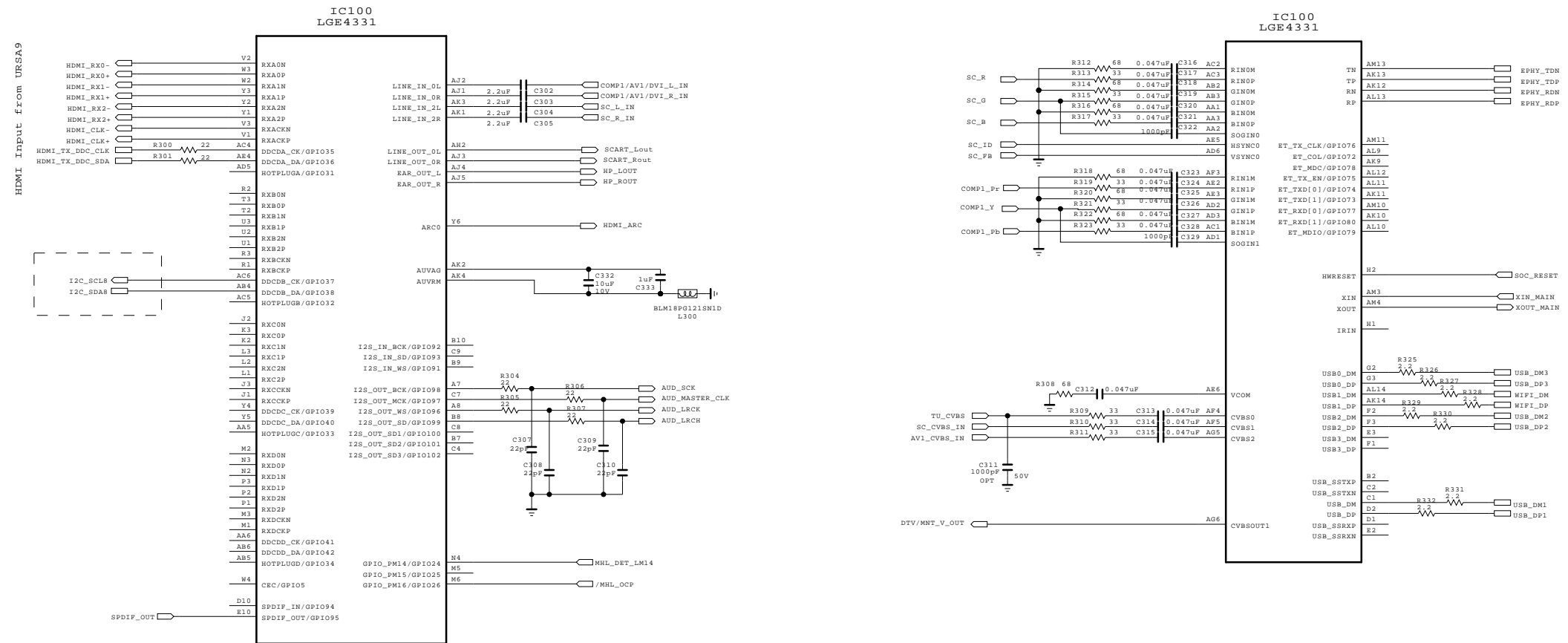
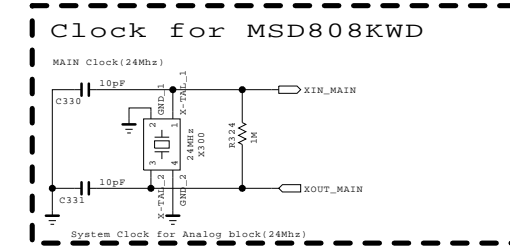
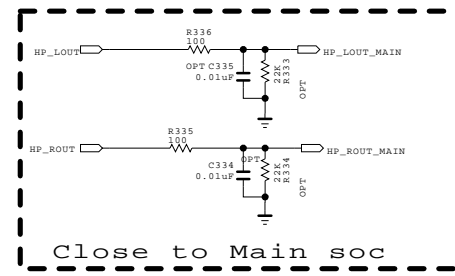

THE SYMBOL MARK OF THIS SCHEMATIC DIAGRAM INCORPORATES SPECIAL FEATURES IMPORTANT FOR PROTECTION FROM X-RADIATION. FIRE AND ELECTRICAL SHOCK HAZARDS, WHEN SERVICING IF IS ESSENTIAL THAT ONLY MANUFACTURERS SPECIFIED PARTS BE USED FOR THE CRITICAL COMPONENTS IN THE SYMBOL MARK OF THE SCHEMATIC.

SECRET  
LGElectronics



MODEL	UB83	DATE	2013-10-28
BLOCK	LM14 INPUT	SHEET	03

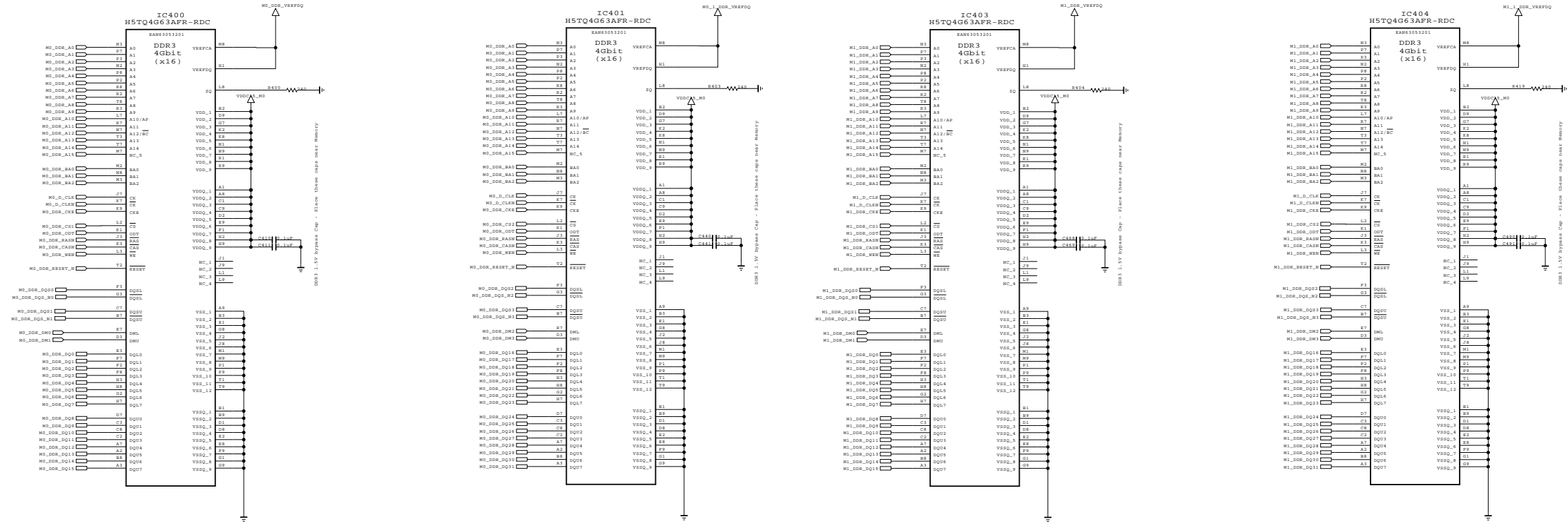

+1.5V\_Bypass Cap  
Close to DDR Power Pin

+1.5V\_Bypass Cap  
Close to DDR Power Pin

+1.5V\_Bypass Cap  
Close to DDR Power Pin

+1.5V\_Bypass Cap  
Close to DDR Power Pin

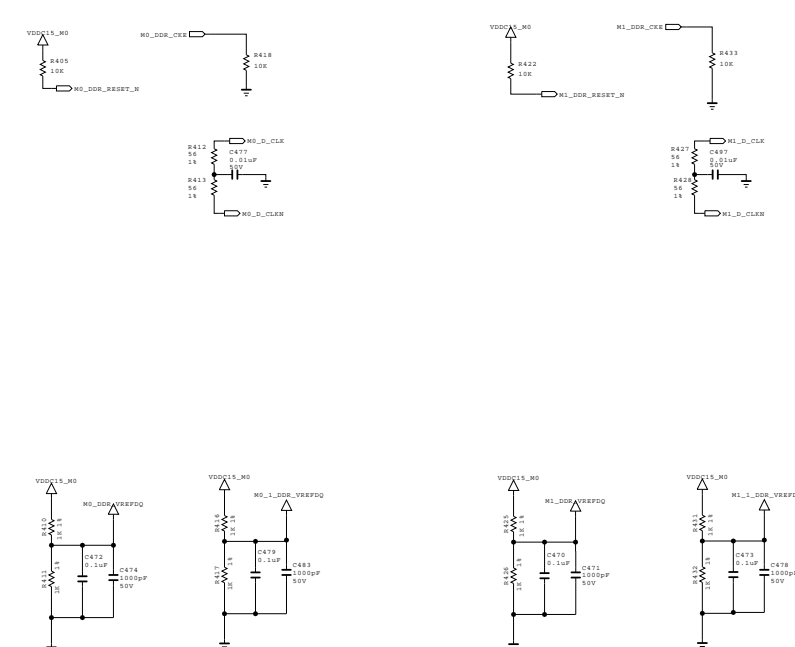
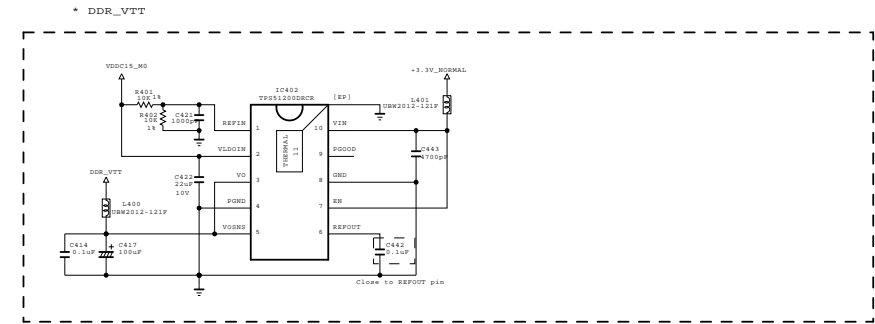
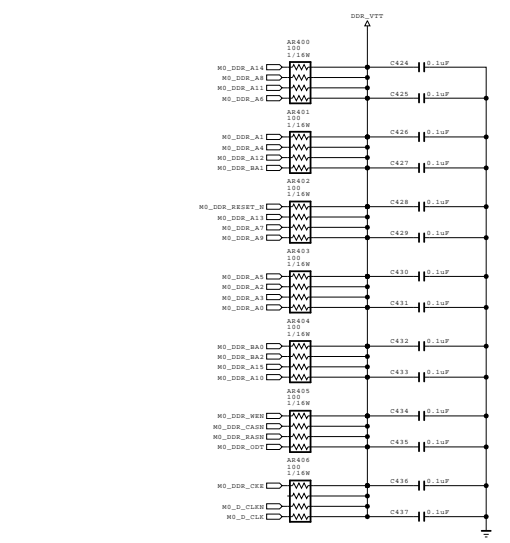
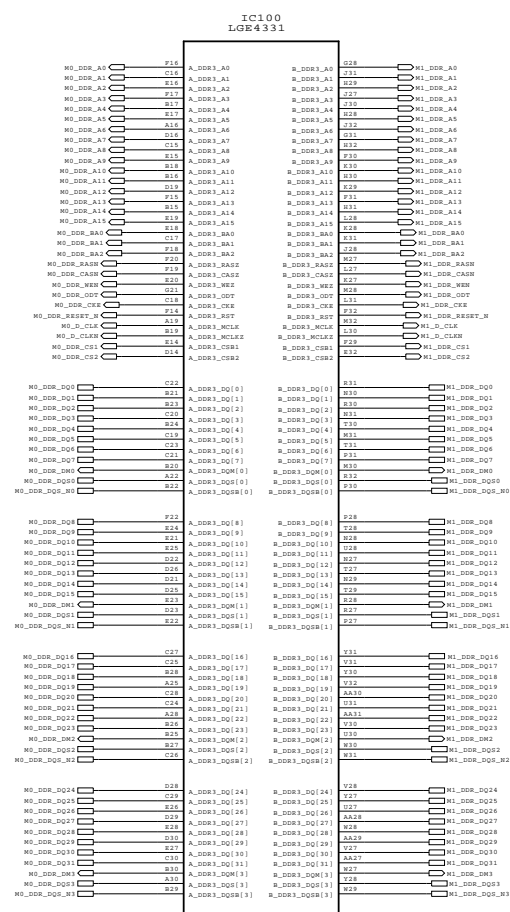
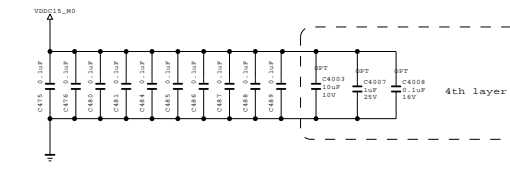
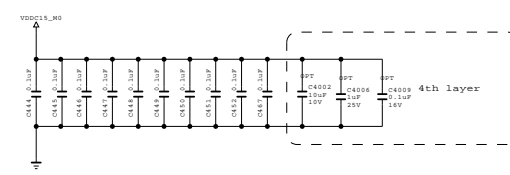
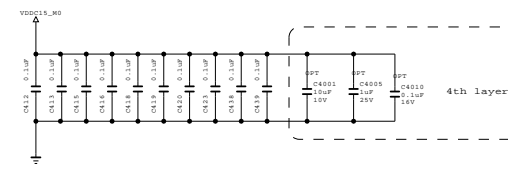
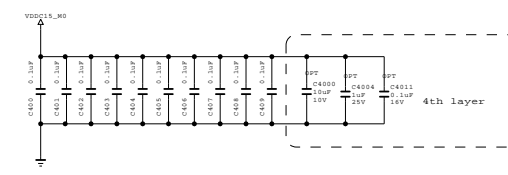

THE  $\Delta$  SYMBOL MARK OF THIS SCHEMATIC DIAGRAM INCORPORATES SPECIAL FEATURES IMPORTANT FOR PROTECTION FROM X-RADIATION. FIRE AND ELECTRICAL SHOCK HAZARDS, WHEN SERVICING IF IS ESSENTIAL THAT ONLY MANUFACTURERS SPECIFIED PARTS BE USED FOR THE CRITICAL COMPONENTS IN THE  $\Delta$  SYMBOL MARK OF THE SCHEMATIC.

SECRET  
LGElectronics

LG ELECTRONICS

MODEL	UB83	DATE	2013-10-28
BLOCK	LM14 DDR	SHEET	04

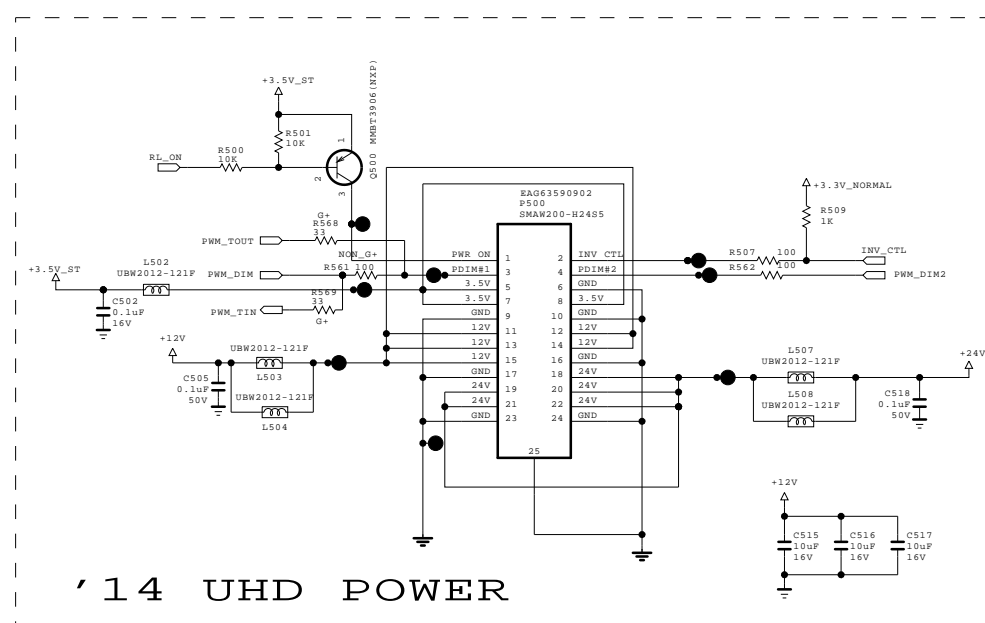

'14 UHD POWER

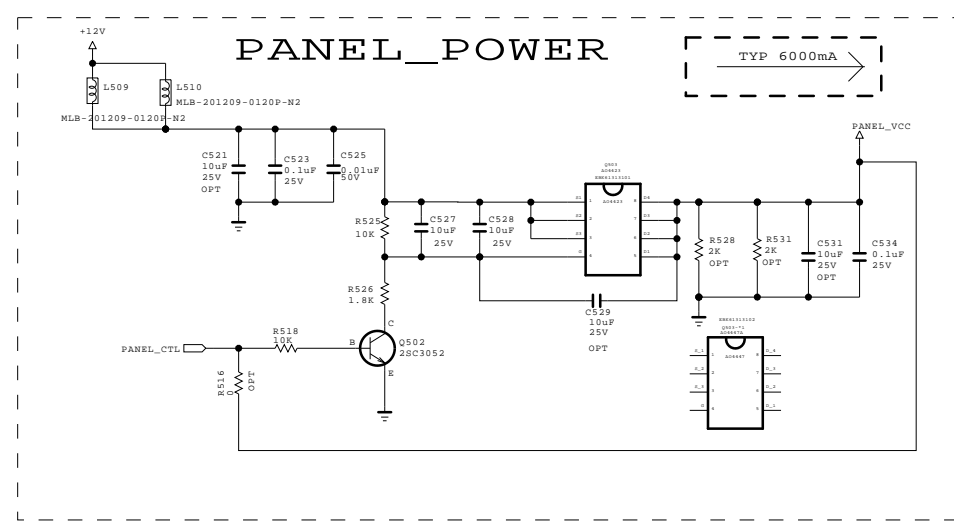

PANEL\_POWER

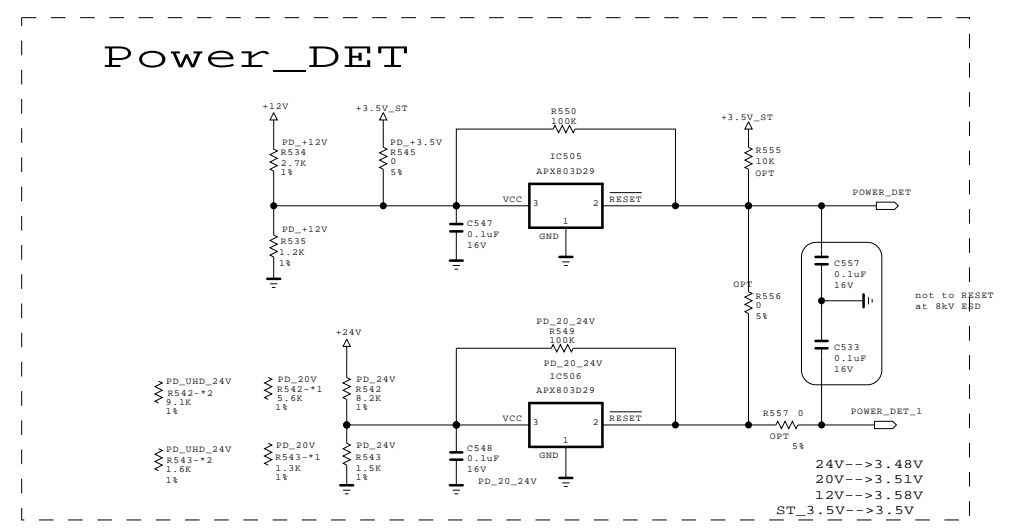

Power\_DET

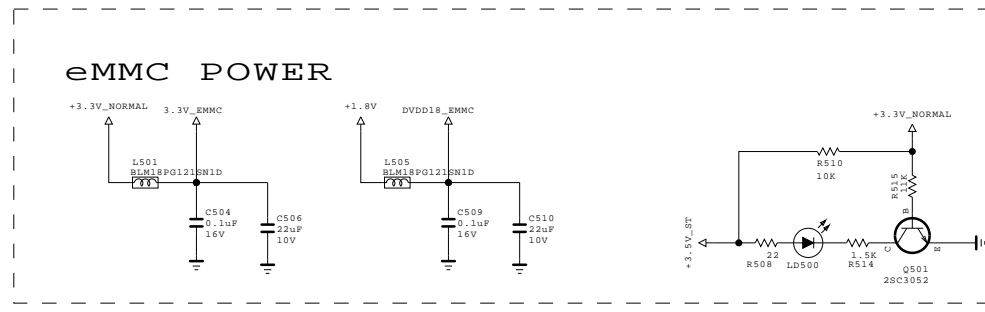

eMMC POWER

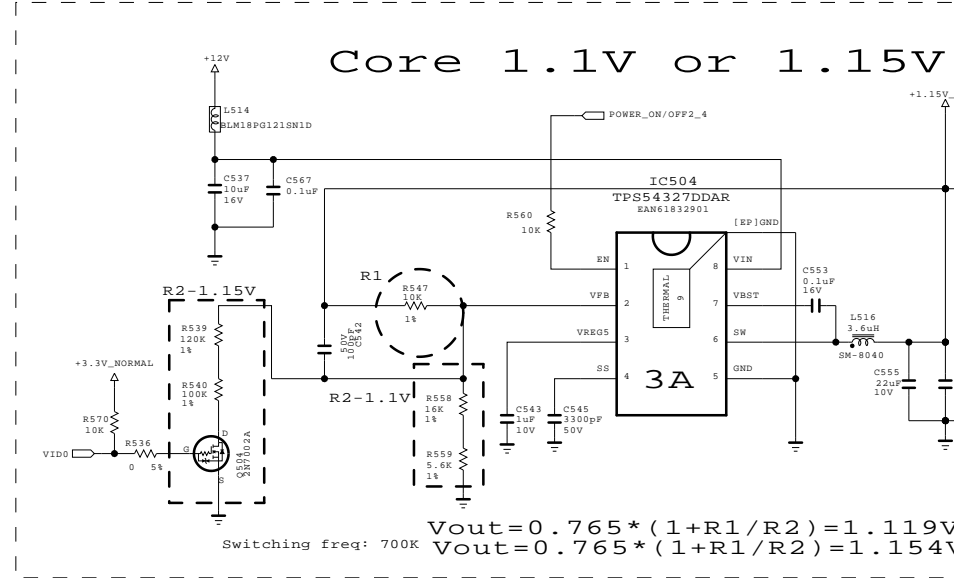

Core 1.1V or 1.15V

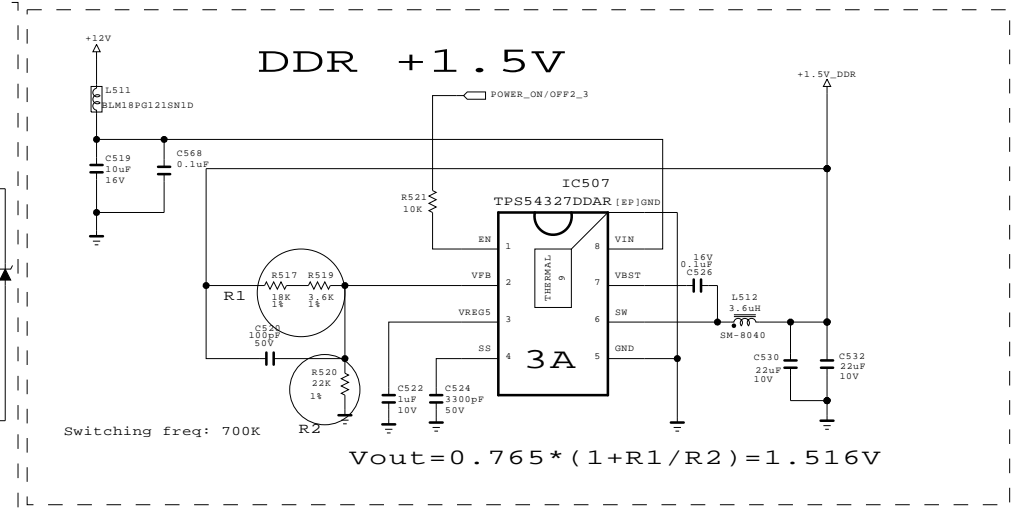

DDR +1.5V

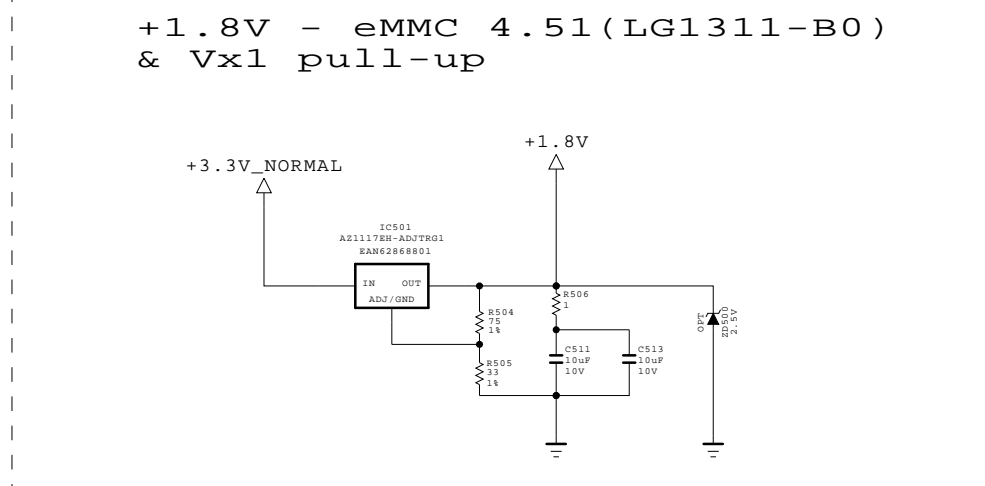

+1.8V - eMMC 4.51 (LG1311-B0) & Vx1 pull-up

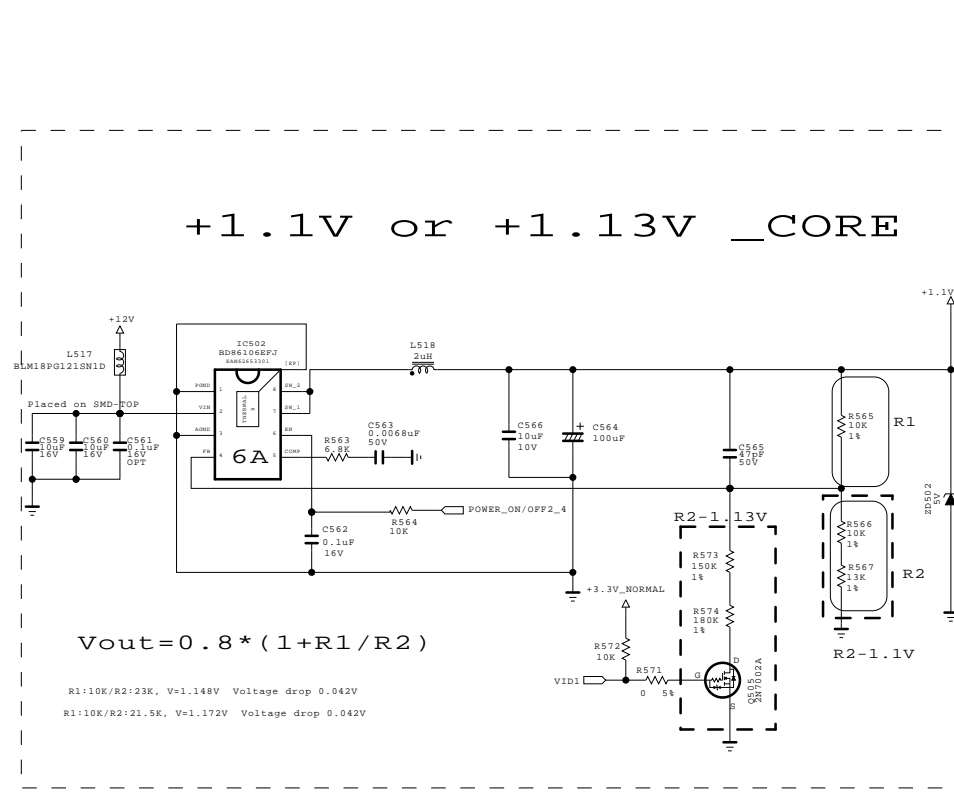

+1.1V or +1.13V CORE

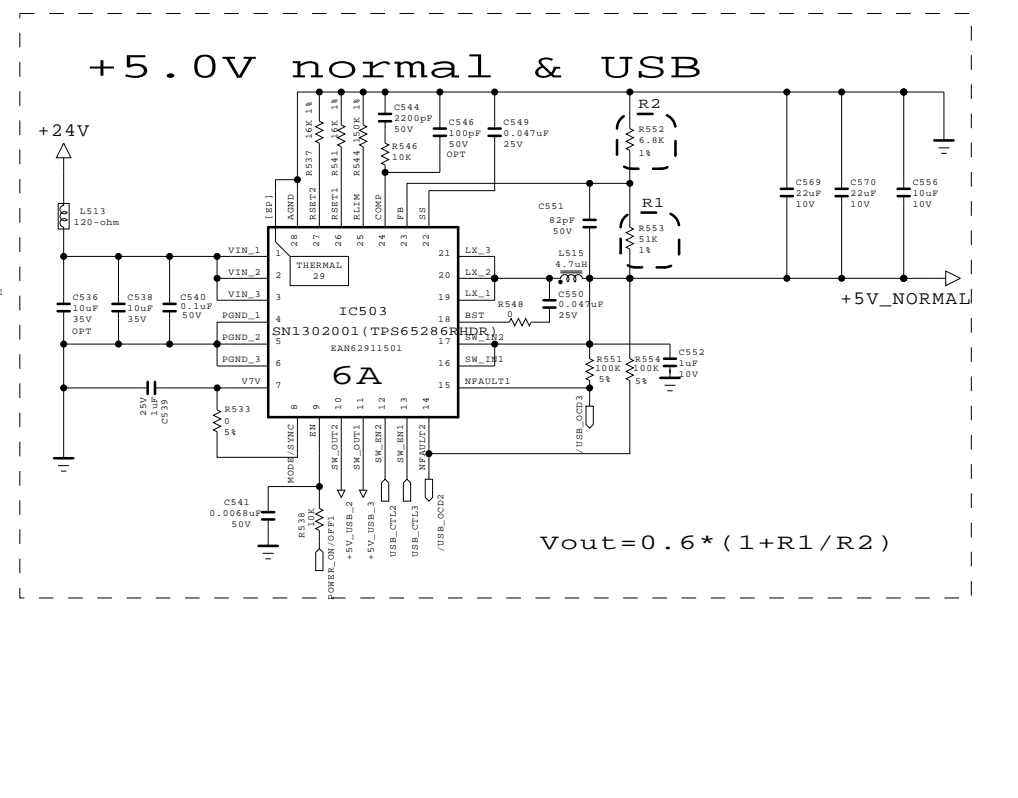

+5.0V normal & USB

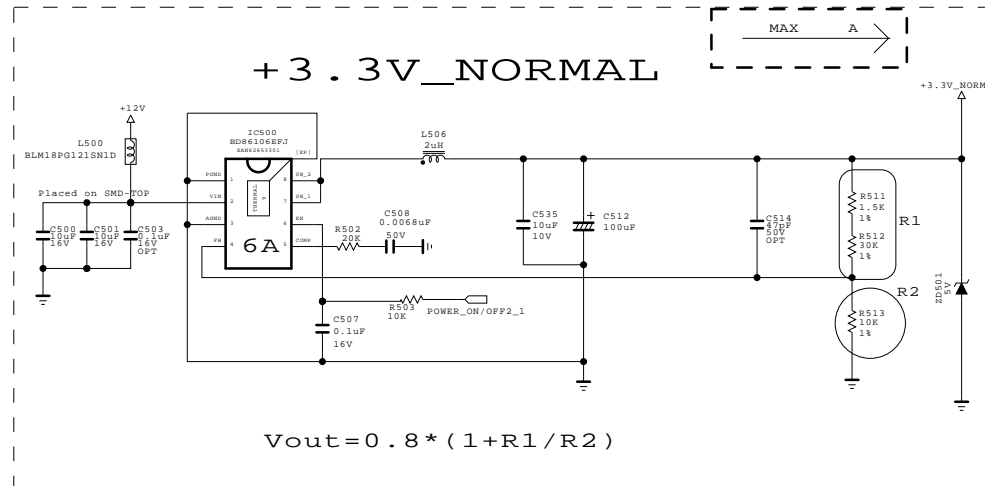

+3.3V\_NORMAL

POWER UP SEQUENCE  
5V/3.3V->1.5V/1.1V->1.0V

THE  $\Delta$  SYMBOL MARK OF THIS SCHEMATIC DIAGRAM INCORPORATES SPECIAL FEATURES IMPORTANT FOR PROTECTION FROM X-RADIATION. FIRE AND ELECTRICAL SHOCK HAZARDS, WHEN SERVICING IF IS ESSENTIAL THAT ONLY MANUFACTURERS SPECIFIED PARTS BE USED FOR THE CRITICAL COMPONENTS IN THE  $\Delta$  SYMBOL MARK OF THE SCHEMATIC.

SECRET  
LGElectronics



MODEL	UB83	DATE	2013-10-28
BLOCK	POWER	SHEET	05

# Renesas MICOM

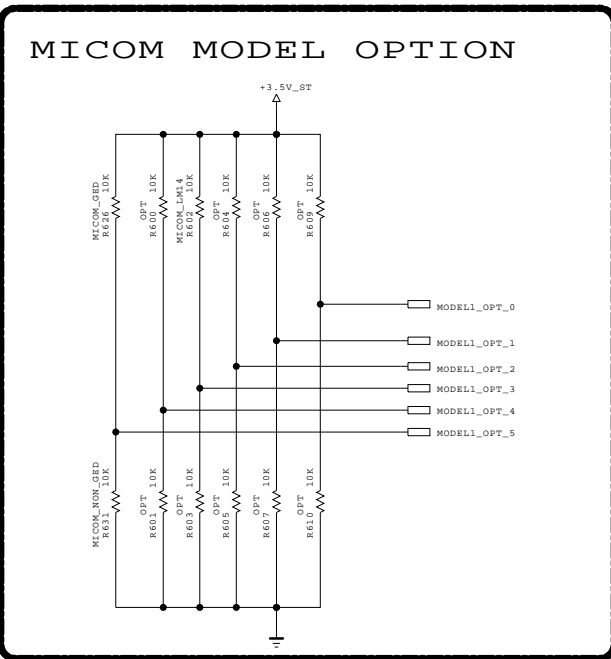
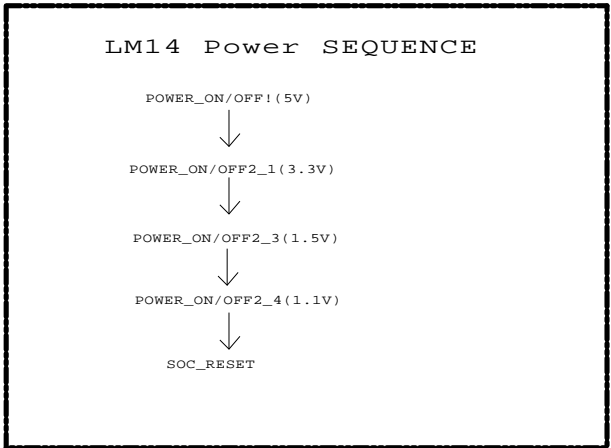
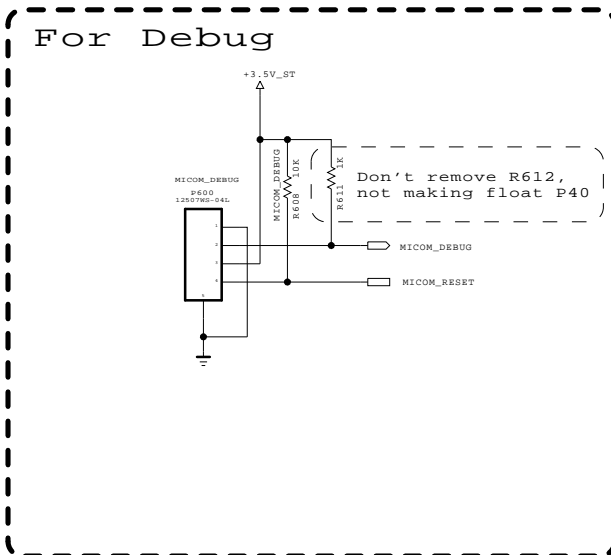

MICOM MODEL OPTION

	0	1	
MODEL_OPT_0			Reserved
MODEL_OPT_1			Reserved
MODEL_OPT_2			Reserved
MODEL_OPT_3		LM14	Reserved
MODEL_OPT_4			Reserved
MODEL_OPT_5	NON_GED	GED	

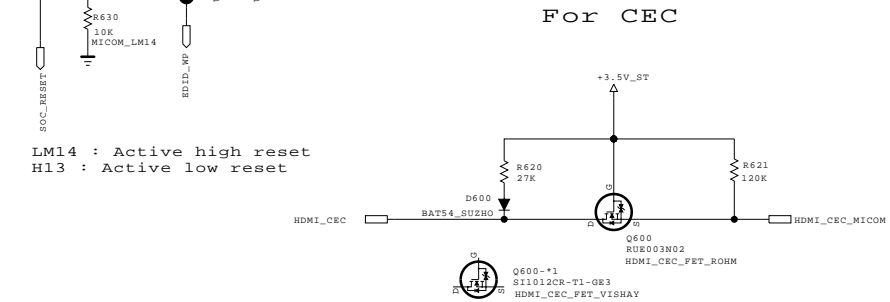
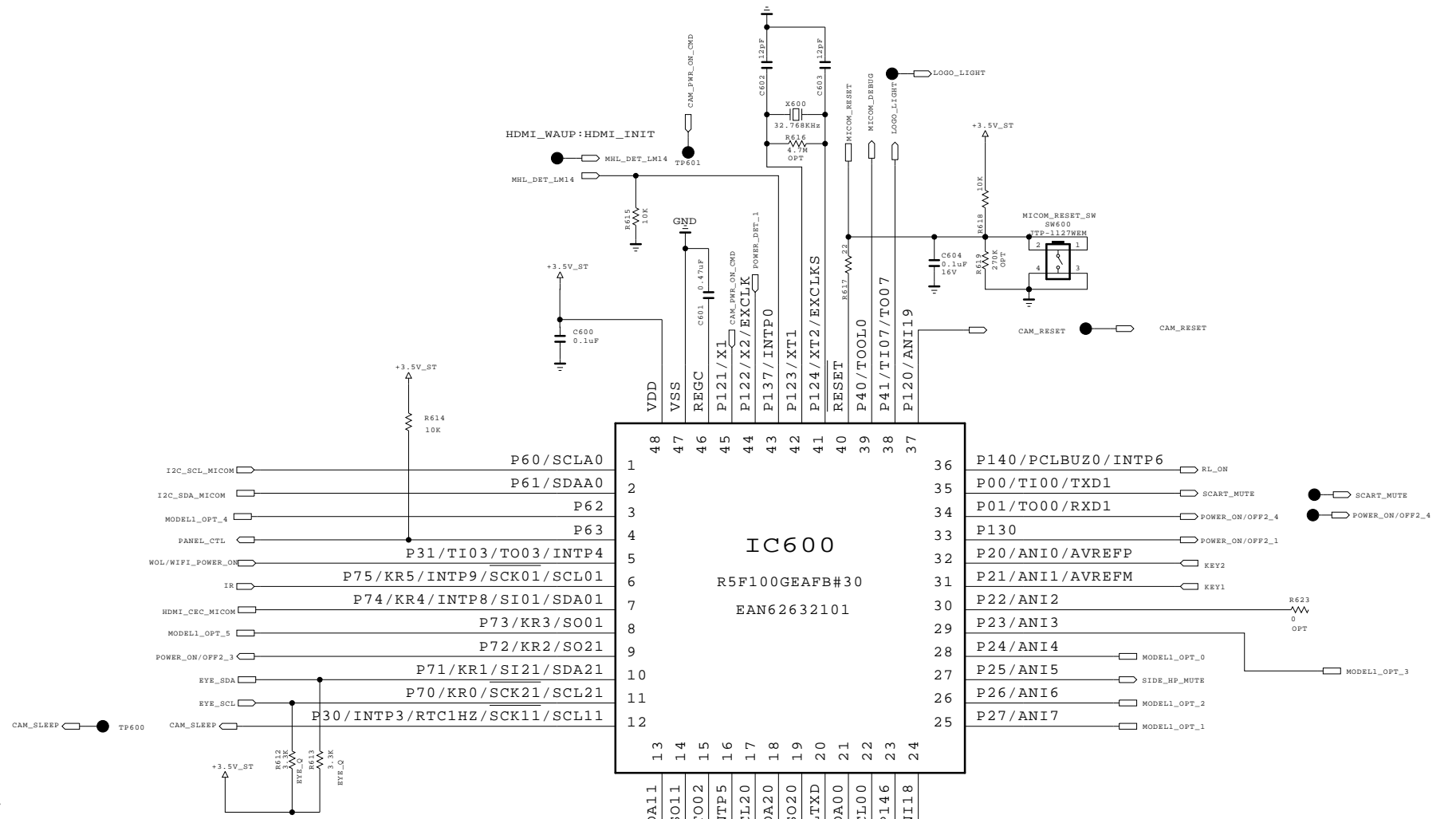

THE  $\Delta$  SYMBOL MARK OF THIS SCHEMATIC DIAGRAM INCORPORATES SPECIAL FEATURES IMPORTANT FOR PROTECTION FROM X-RADIATION. FIRE AND ELECTRICAL SHOCK HAZARDS, WHEN SERVICING IT IS ESSENTIAL THAT ONLY MANUFACTURERS SPECIFIED PARTS BE USED FOR THE CRITICAL COMPONENTS IN THE  $\Delta$  SYMBOL MARK OF THE SCHEMATIC.

SECRET  
LGElectronics



MODEL	UB83	DATE	2013-10-28
BLOCK	MICOM	SHEET	06

# HDMI (HDMI1 HDCP2.2 / HDMI2 ARC / HDMI4 MHL)

R9531 +1.0V else: Max 0.7A

SPI FLASH (2MBit)

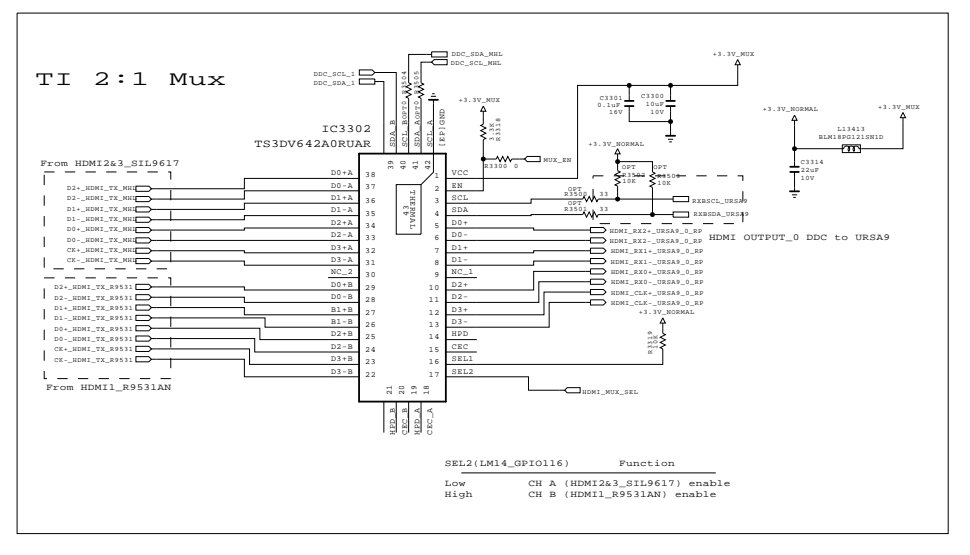
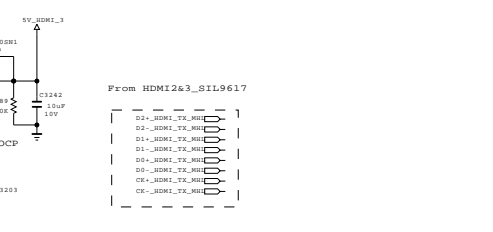
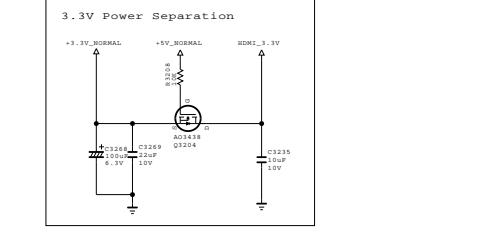
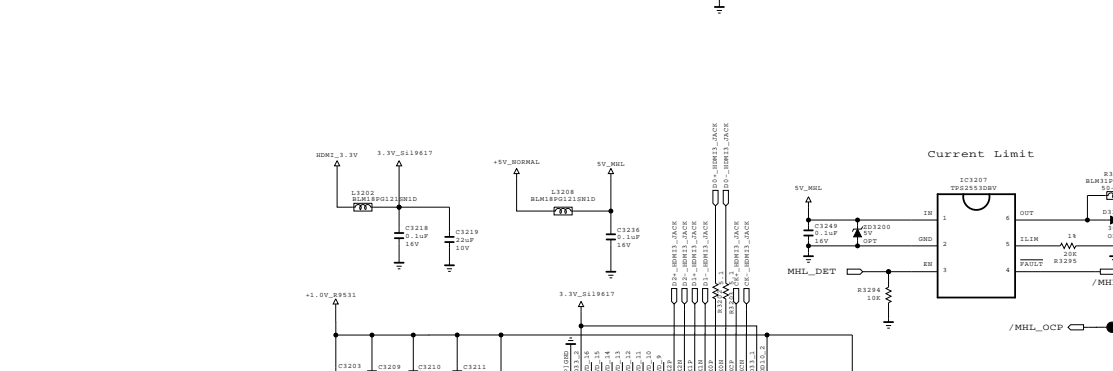
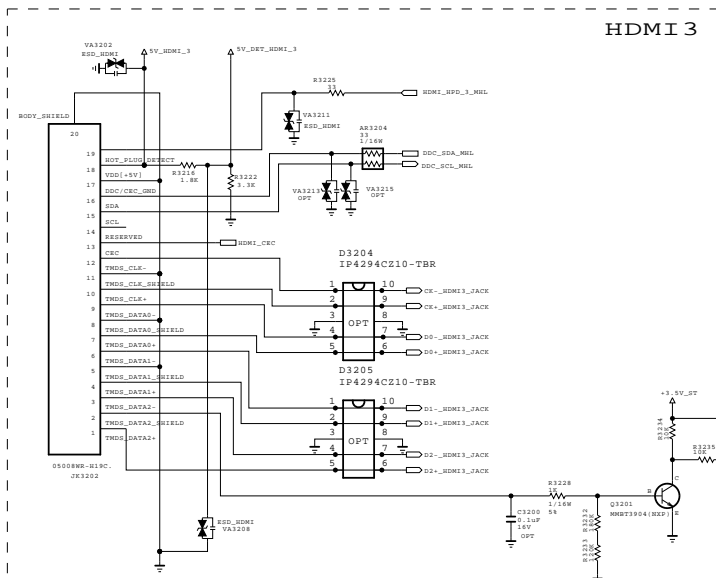
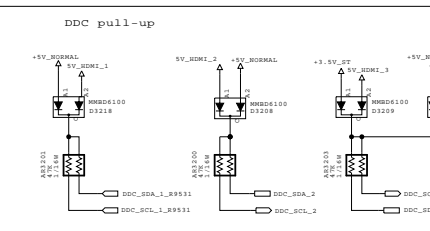
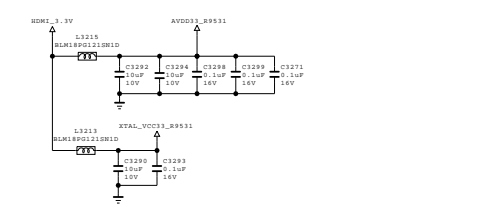
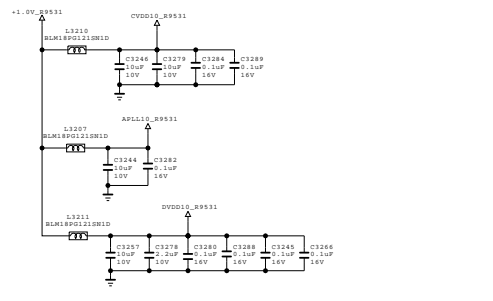
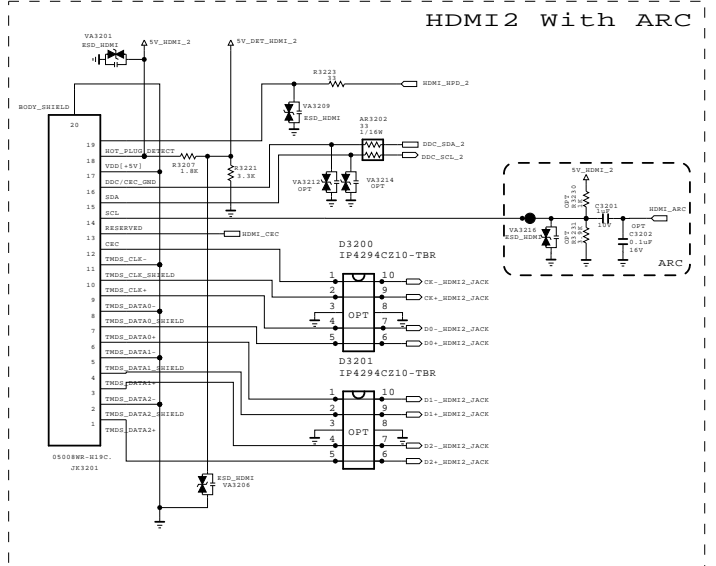
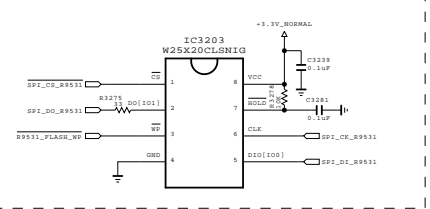
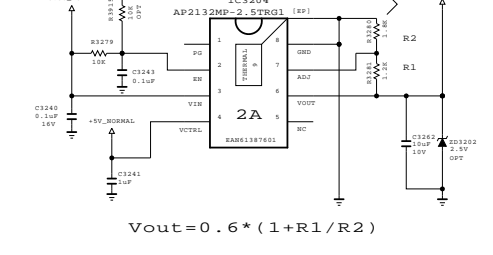
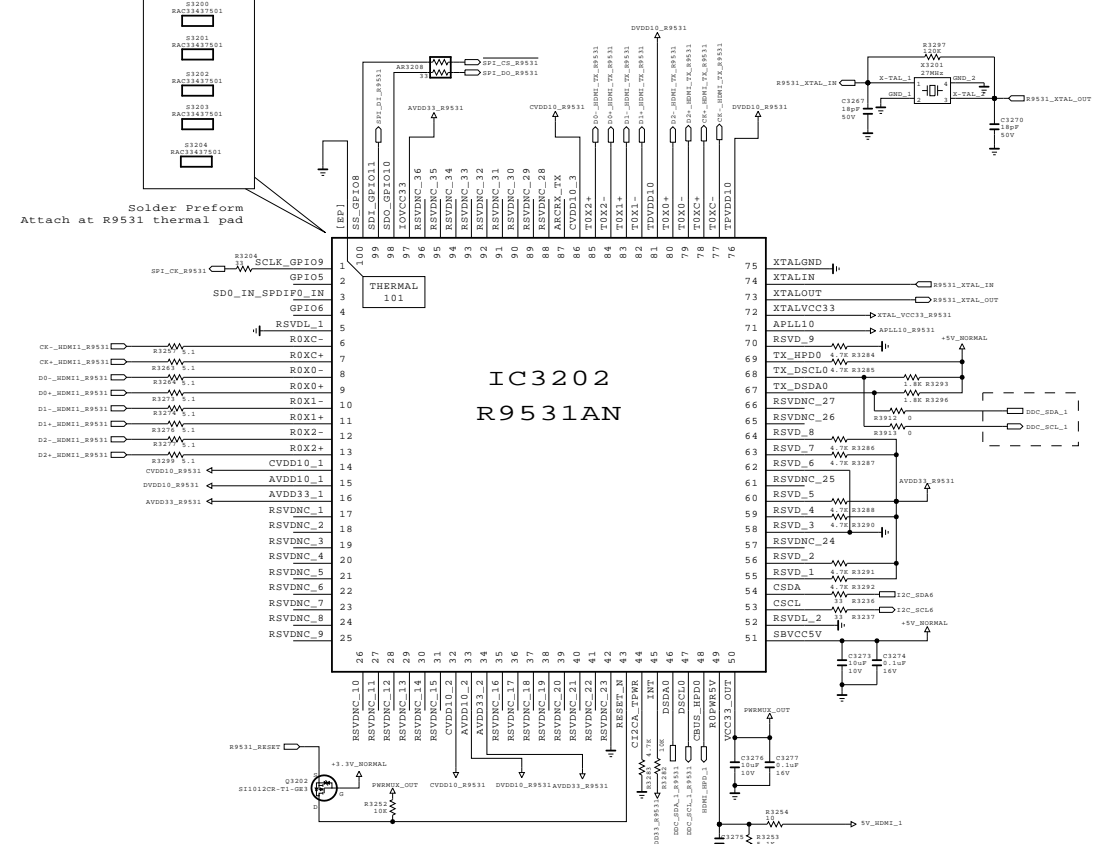
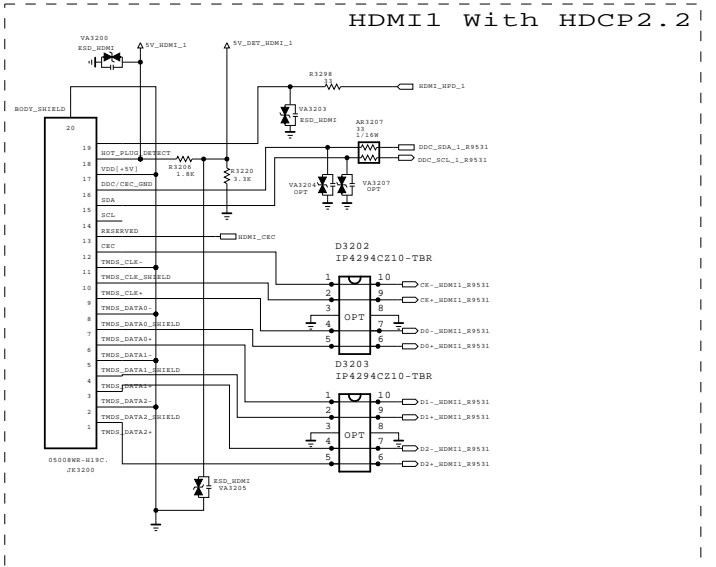

THE Δ SYMBOL MARK OF THIS SCHEMATIC DIAGRAM INCORPORATES SPECIAL FEATURES IMPORTANT FOR PROTECTION FROM X-RADIATION. FIRE AND ELECTRICAL SHOCK HAZARDS, WHEN SERVICING IF IS ESSENTIAL THAT ONLY MANUFACTURERS SPECIFIED PARTS BE USED FOR THE CRITICAL COMPONENTS IN THE Δ SYMBOL MARK OF THE SCHEMATIC.

SECRET  
LGElectronics

LG ELECTRONICS

MODEL	UB83	DATE	2013-10-28
BLOCK	HDMI JACK	SHEET	07

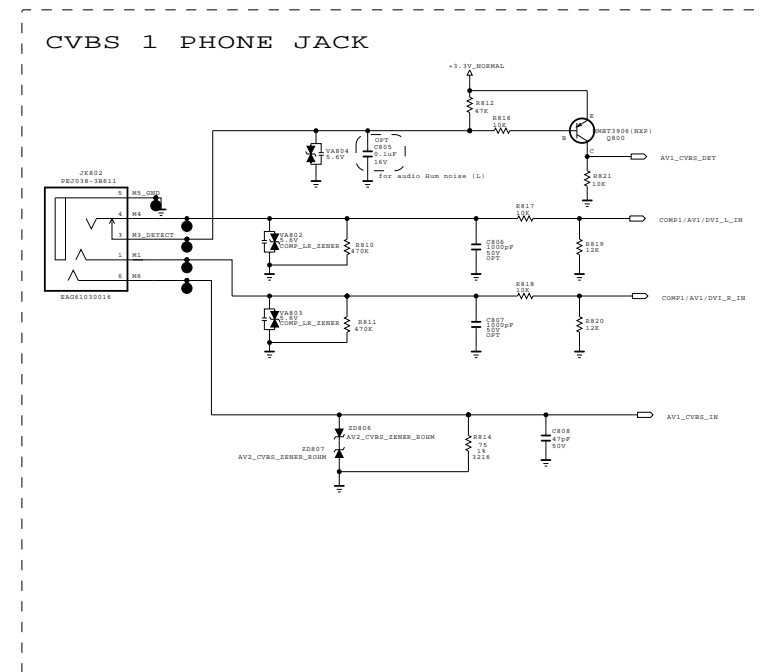
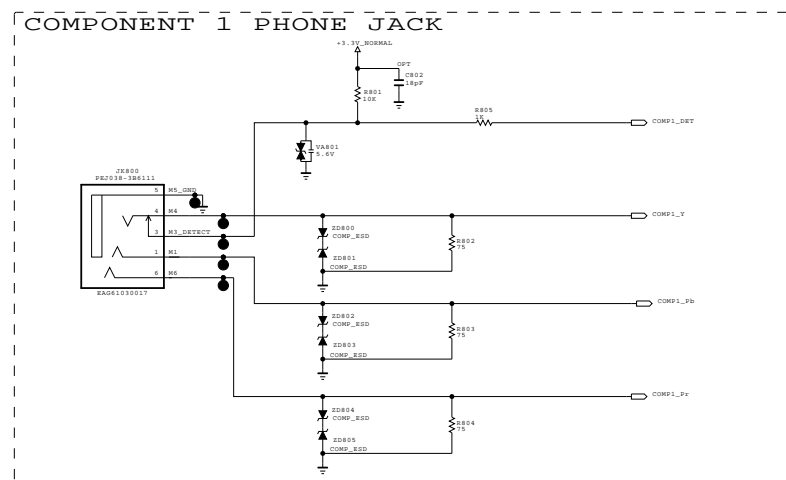
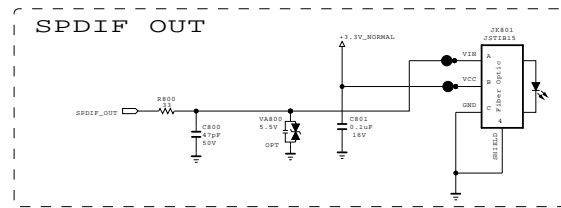

THE SYMBOL MARK OF THIS SCHEMATIC DIAGRAM INCORPORATES SPECIAL FEATURES IMPORTANT FOR PROTECTION FROM X-RADIATION. FIRE AND ELECTRICAL SHOCK HAZARDS, WHEN SERVICING IF IS ESSENTIAL THAT ONLY MANUFACTURERS SPECIFIED PARTS BE USED FOR THE CRITICAL COMPONENTS IN THE SYMBOL MARK OF THE SCHEMATIC.

SECRET  
LGElectronics

LG ELECTRONICS

MODEL	UB83	DATE	2013-10-28
BLOCK	AV&COMP JACK	SHEET	08 /



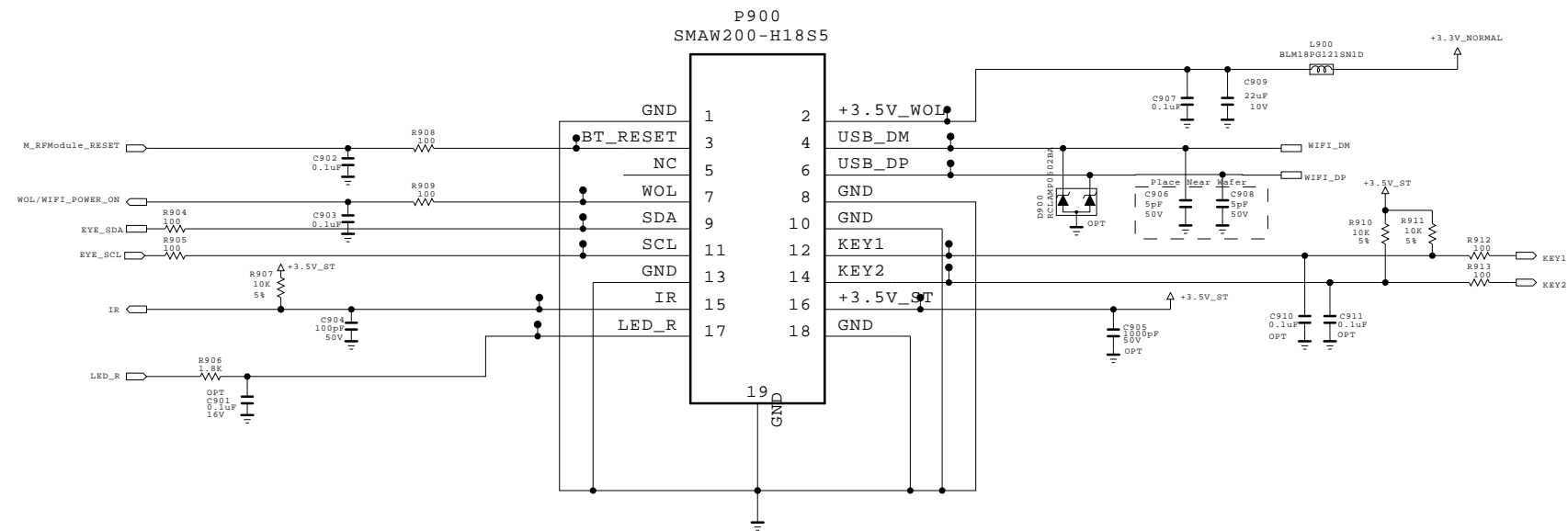

SMD bottom for ESD\_UB8 10.5T

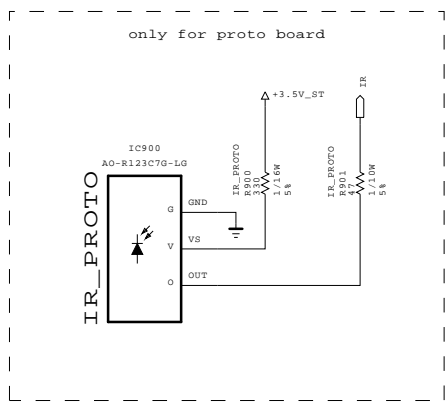
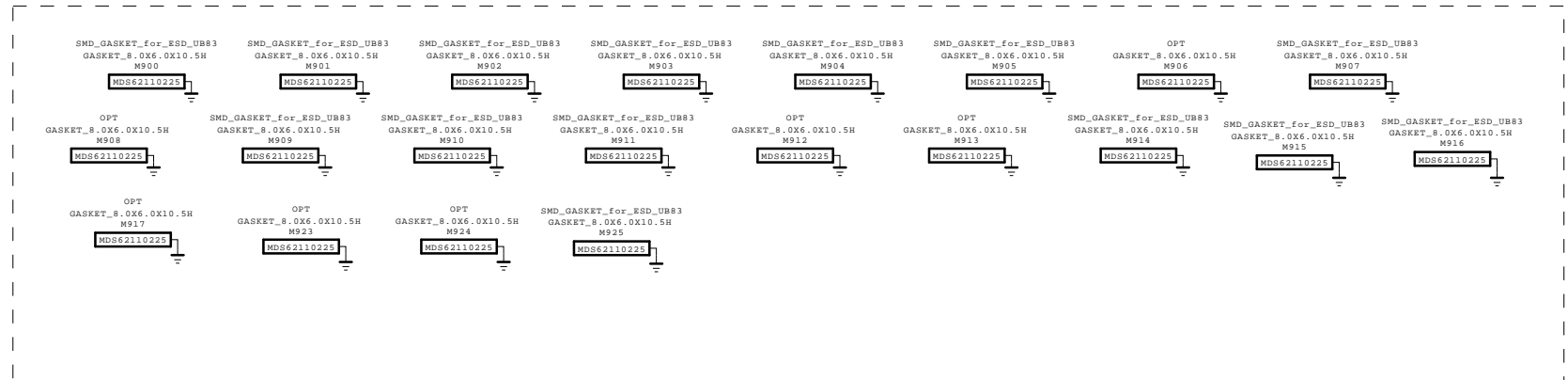

SMD TOP for EMI\_UB8 13.5T

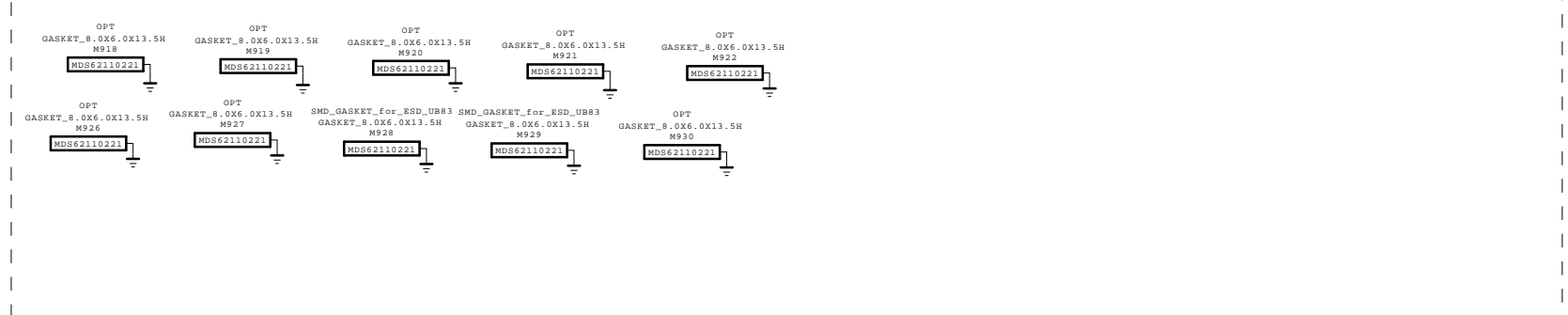

THE SYMBOL MARK OF THIS SCHEMATIC DIAGRAM INCORPORATES SPECIAL FEATURES IMPORTANT FOR PROTECTION FROM X-RADIATION. FIRE AND ELECTRICAL SHOCK HAZARDS, WHEN SERVICING IF IS ESSENTIAL THAT ONLY MANUFACTURERS SPECIFIED PARTS BE USED FOR THE CRITICAL COMPONENTS IN THE SYMBOL MARK OF THE SCHEMATIC.

SECRET  
LGElectronics



MODEL	UB83	DATE	2013-10-28
BLOCK	IR/KEY/WIFI/BT	SHEET	09 /

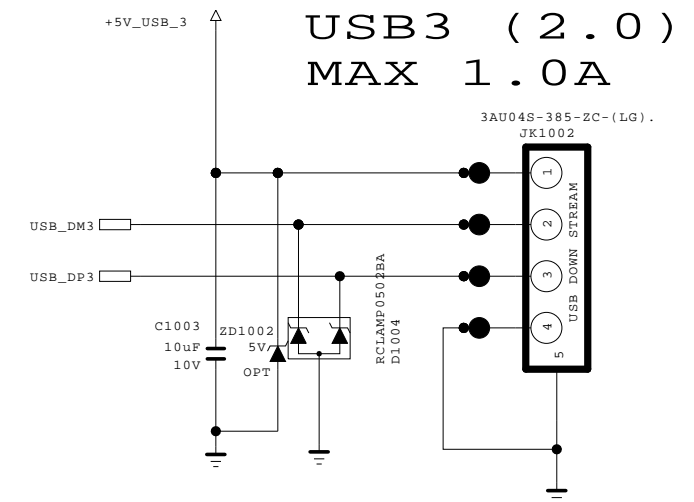
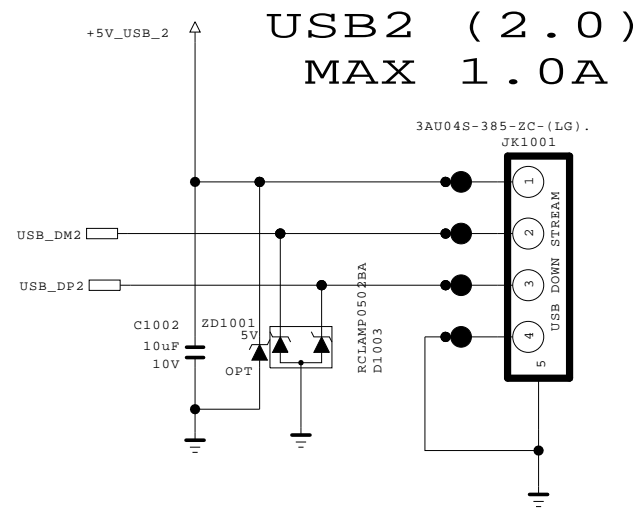
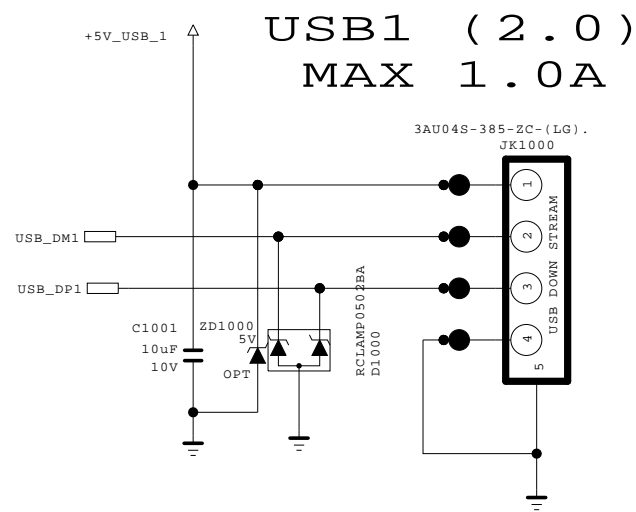

### OCP USB1

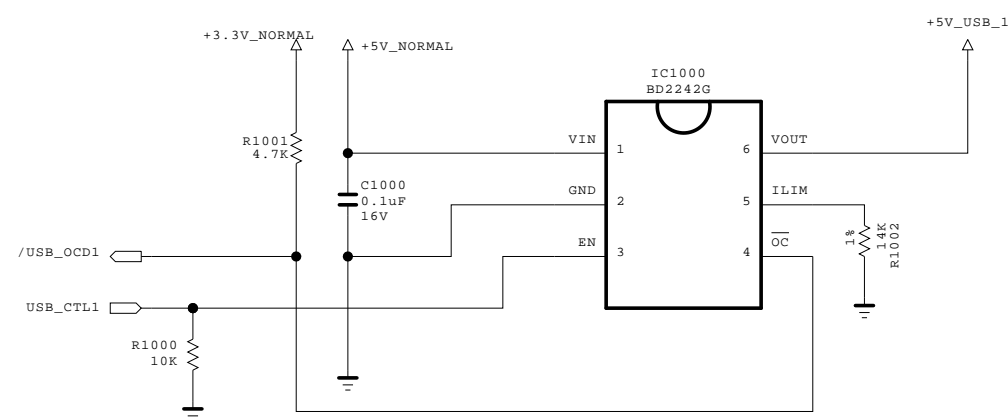

THE SYMBOL MARK OF THIS SCHEMATIC DIAGRAM INCORPORATES SPECIAL FEATURES IMPORTANT FOR PROTECTION FROM X-RADIATION. FIRE AND ELECTRICAL SHOCK HAZARDS, WHEN SERVICING IF IS ESSENTIAL THAT ONLY MANUFACTURERS SPECIFIED PARTS BE USED FOR THE CRITICAL COMPONENTS IN THE SYMBOL MARK OF THE SCHEMATIC.

<b>SECRET</b>	LG ELECTRONICS
LGElectronics	

MODEL	UB83	DATE	2013-10-28
BLOCK	USB JACK	SHEET	10 /

# Ethernet Block

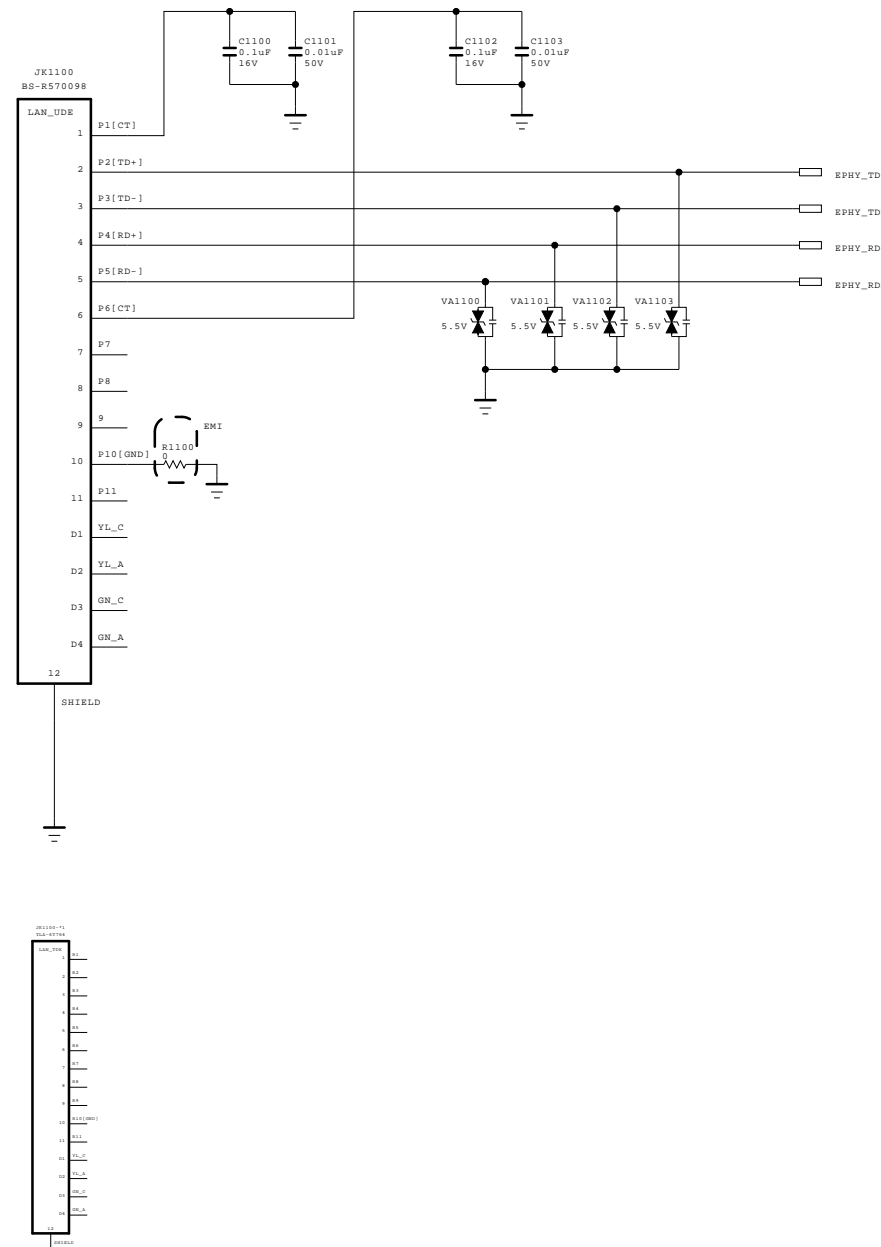

THE SYMBOL MARK OF THIS SCHEMATIC DIAGRAM INCORPORATES SPECIAL FEATURES IMPORTANT FOR PROTECTION FROM X-RADIATION. FIRE AND ELECTRICAL SHOCK HAZARDS, WHEN SERVICING IF IS ESSENTIAL THAT ONLY MANUFACTURERS SPECIFIED PARTS BE USED FOR THE CRITICAL COMPONENTS IN THE SYMBOL MARK OF THE SCHEMATIC.

**SECRET**  
LGElectronics



MODEL	UB83	DATE	2013-10-28
BLOCK	LAN JACK	SHEET	11 /

# Main AMP

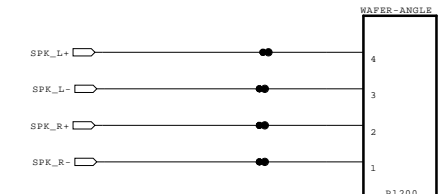
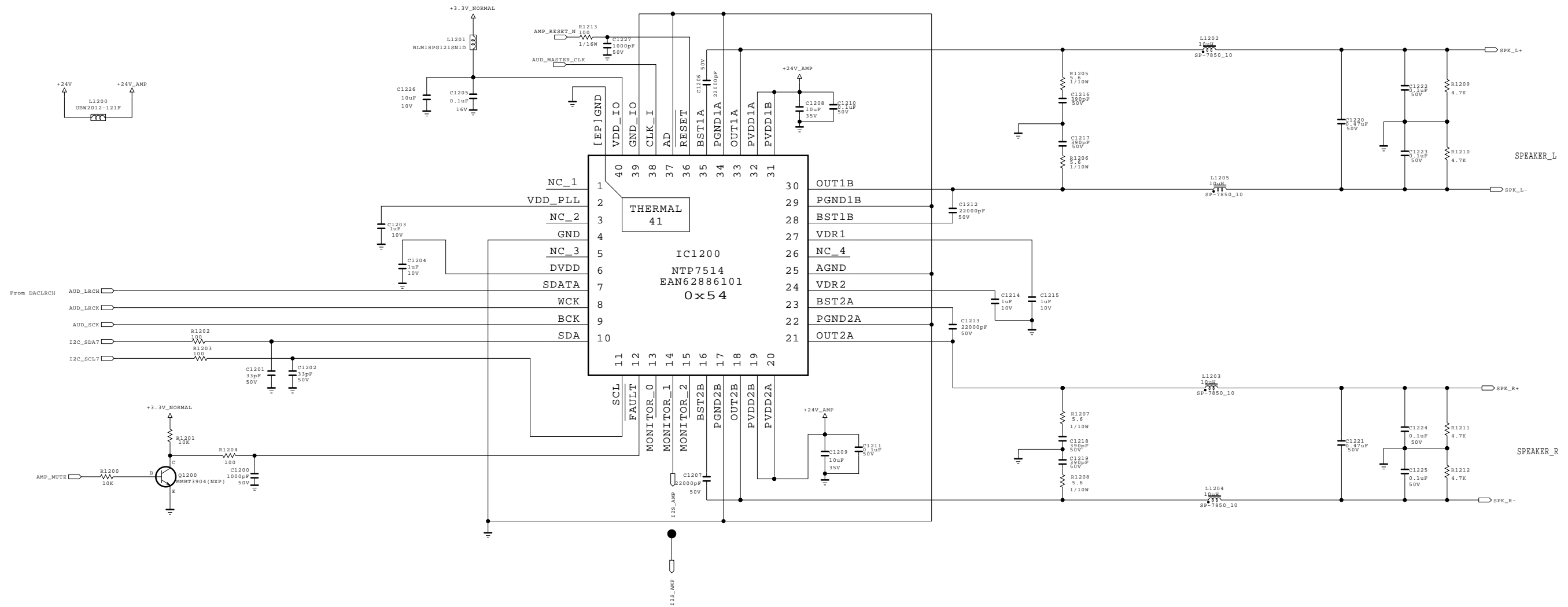

THE SYMBOL MARK OF THIS SCHEMATIC DIAGRAM INCORPORATES SPECIAL FEATURES IMPORTANT FOR PROTECTION FROM X-RADIATION. FIRE AND ELECTRICAL SHOCK HAZARDS, WHEN SERVICING IT IS ESSENTIAL THAT ONLY MANUFACTURERS SPECIFIED PARTS BE USED FOR THE CRITICAL COMPONENTS IN THE SYMBOL MARK OF THE SCHEMATIC.

**SECRET**  
LGElectronics



MODEL	UB83	DATE	2013-10-28
BLOCK	MAIN AMP	SHEET	12 /

# EARPHONE AMP

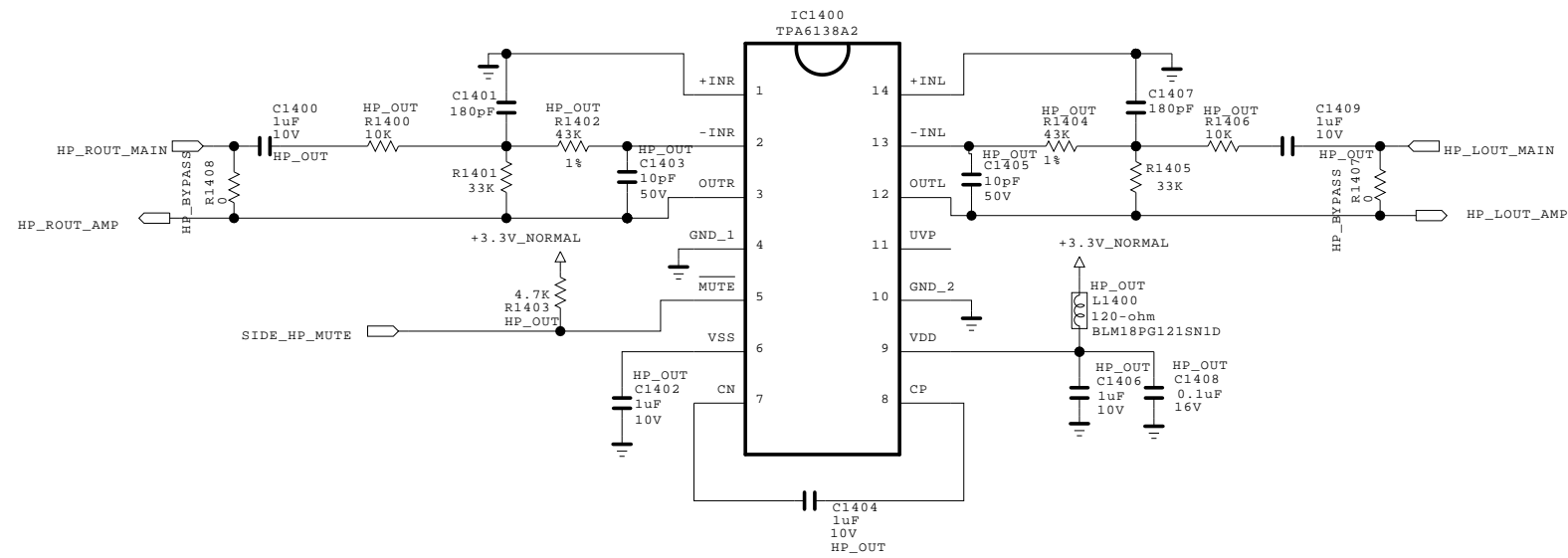

THE SYMBOL MARK OF THIS SCHEMATIC DIAGRAM INCORPORATES SPECIAL FEATURES IMPORTANT FOR PROTECTION FROM X-RADIATION. FIRE AND ELECTRICAL SHOCK HAZARDS, WHEN SERVICING IF IS ESSENTIAL THAT ONLY MANUFACTURERS SPECIFIED PARTS BE USED FOR THE CRITICAL COMPONENTS IN THE SYMBOL MARK OF THE SCHEMATIC.

**SECRET**  
LGElectronics

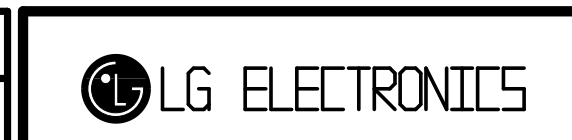

MODEL	UB83	DATE	2013-10-28
BLOCK	HEADPHONE AMP	SHEET	14 /

1. should be guarded by ground
2. No via on both of them
3. Signal Width >= 12mils  
Signal to Signal Width = 12mils  
Ground Width >= 24mils

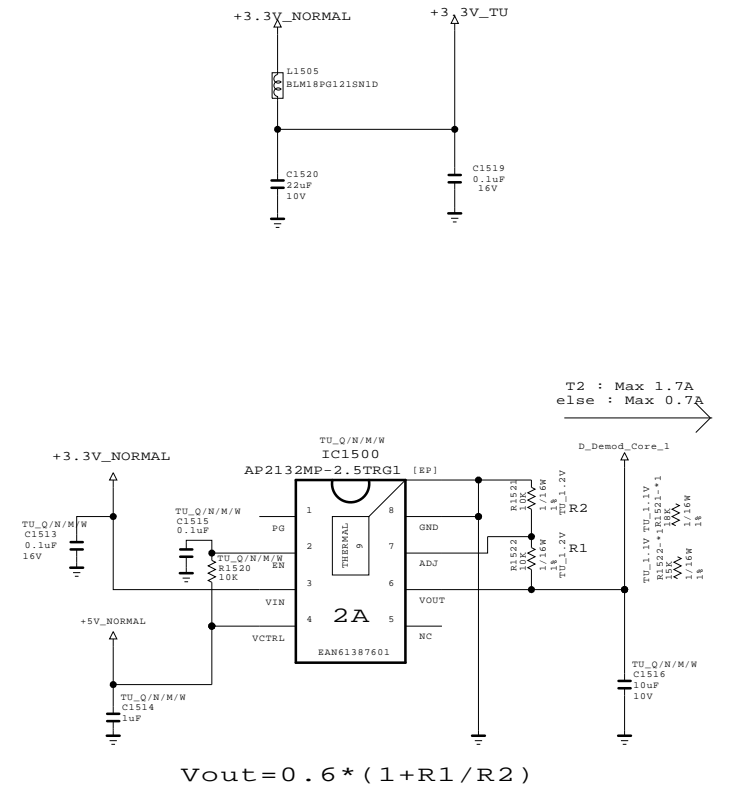
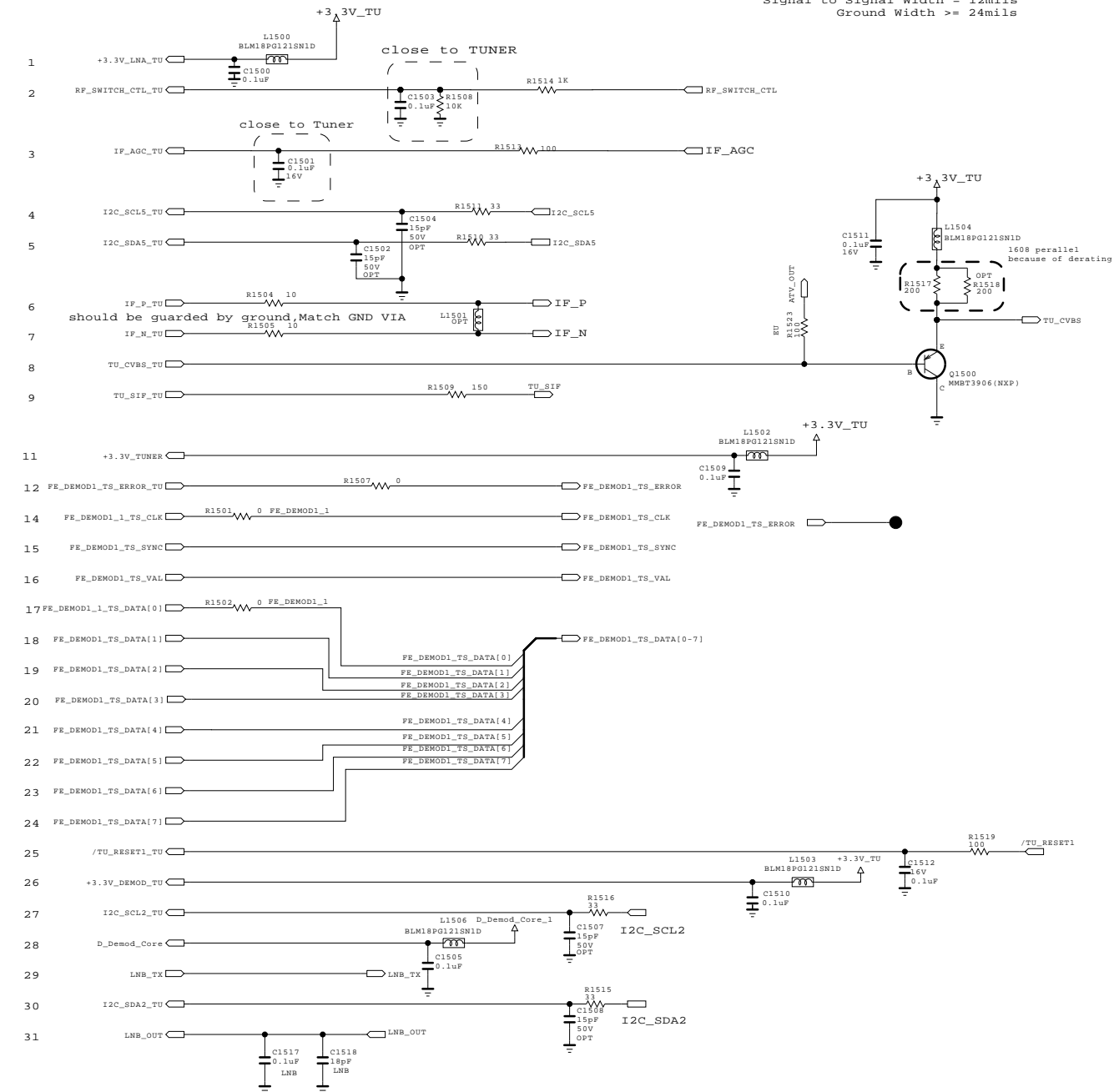

Global F/E Option Name  
 1. TU  
 2. Tuner Name = TDS'S',TDS'Q'...  
 3. Country Name = T,T2,S2,KR,US,BR ...

Example of Option name  
 TU\_Q\_T2 = apply TDSQ type tuner and T2 country  
 TU\_M/W = apply TDSM&TDSW Type Tuner

13' Tuner Type for Global  
 TDS'S'-G501D : T/C Half NIM Horizontal Type  
 TDS'Q'-G501D : T/C/S2 Combo Horizontal type  
 TDS'Q'-G601D : T2/C/S2 Combo Horizontal Type  
 TDS'Q'-G651D : T2/C/S2 Combo Vertical Type  
 TDS'M'-C601D : China NIM with Isolater Type  
 TDS'W'-J551F : Japan Dual NIM  
 TDS'W'-B651F : Brazil 2Tuner  
 TDS'W'-A651F : Taiwan 2Tuner  
 TDS'W'-K651F : Colombia DVB-T2 2Tuner

THE  $\Delta$  SYMBOL MARK OF THIS SCHEMATIC DIAGRAM INCORPORATES SPECIAL FEATURES IMPORTANT FOR PROTECTION FROM X-RADIATION. FIRE AND ELECTRICAL SHOCK HAZARDS, WHEN SERVICING IF IS ESSENTIAL THAT ONLY MANUFACTURERS SPECIFIED PARTS BE USED FOR THE CRITICAL COMPONENTS IN THE  $\Delta$  SYMBOL MARK OF THE SCHEMATIC.

SECRET  
 LGElectronics



MODEL	UB83	DATE	2013-10-28
BLOCK	TU CIRCUIT	SHEET	15

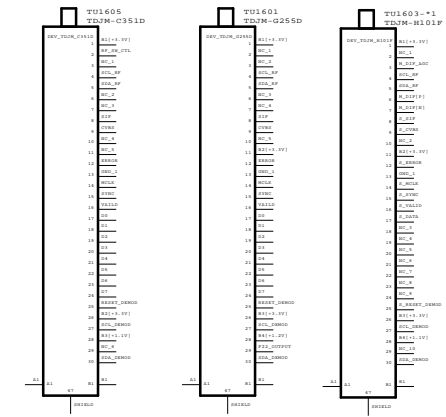
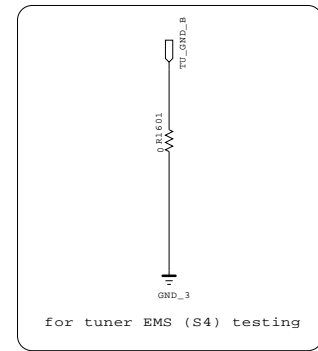
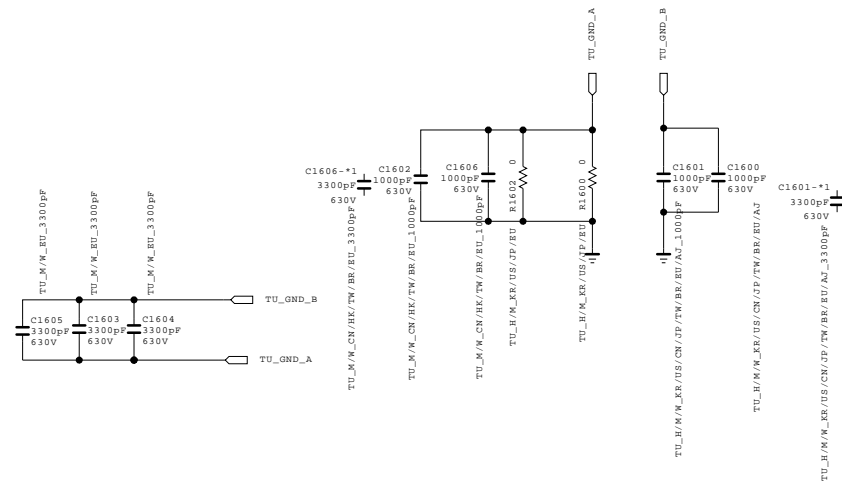
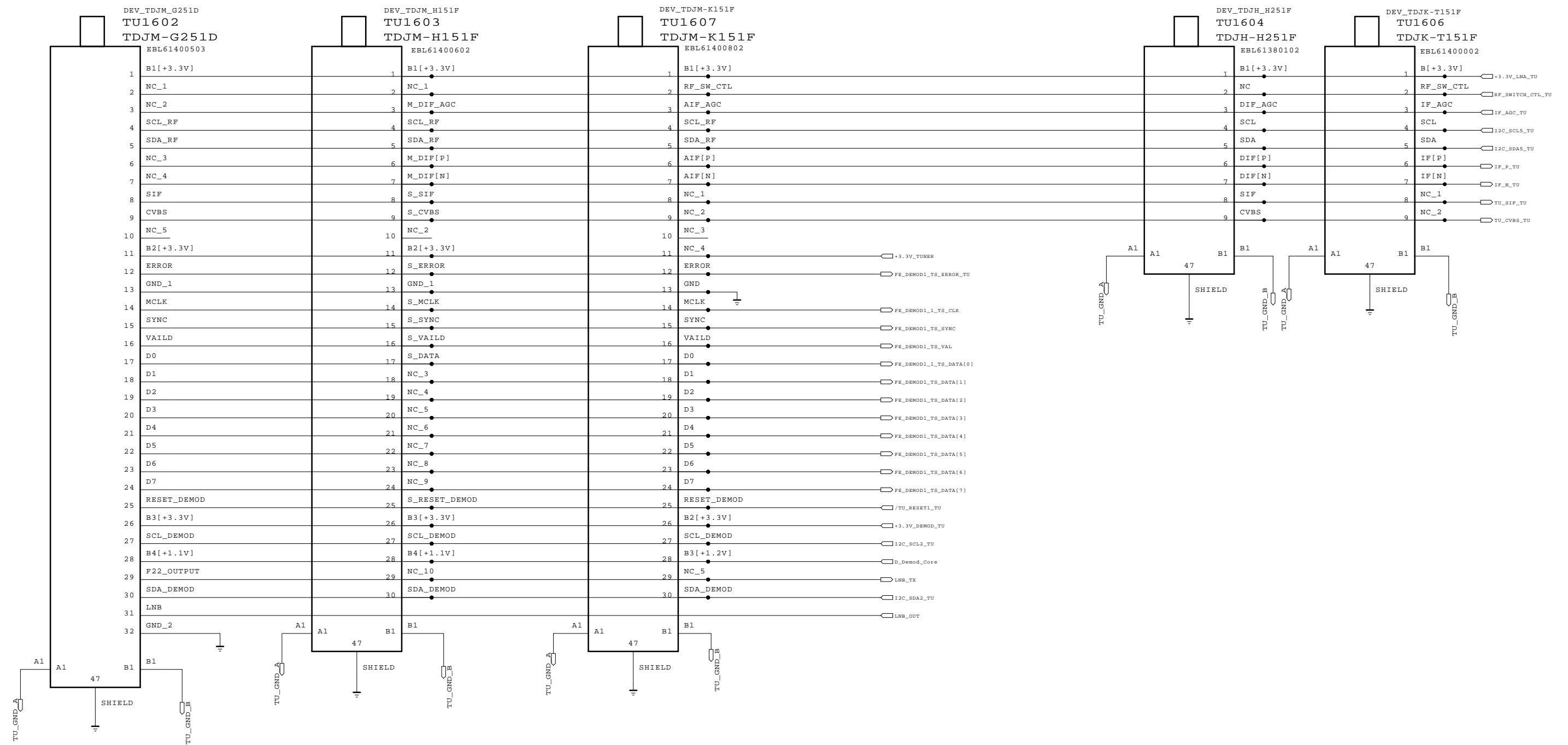

THE SYMBOL MARK OF THIS SCHEMATIC DIAGRAM INCORPORATES SPECIAL FEATURES IMPORTANT FOR PROTECTION FROM X-RADIATION. FIRE AND ELECTRICAL SHOCK HAZARDS, WHEN SERVICING IF IS ESSENTIAL THAT ONLY MANUFACTURERS SPECIFIED PARTS BE USED FOR THE CRITICAL COMPONENTS IN THE SYMBOL MARK OF THE SCHEMATIC.



**SECRET**  
LGElectronics

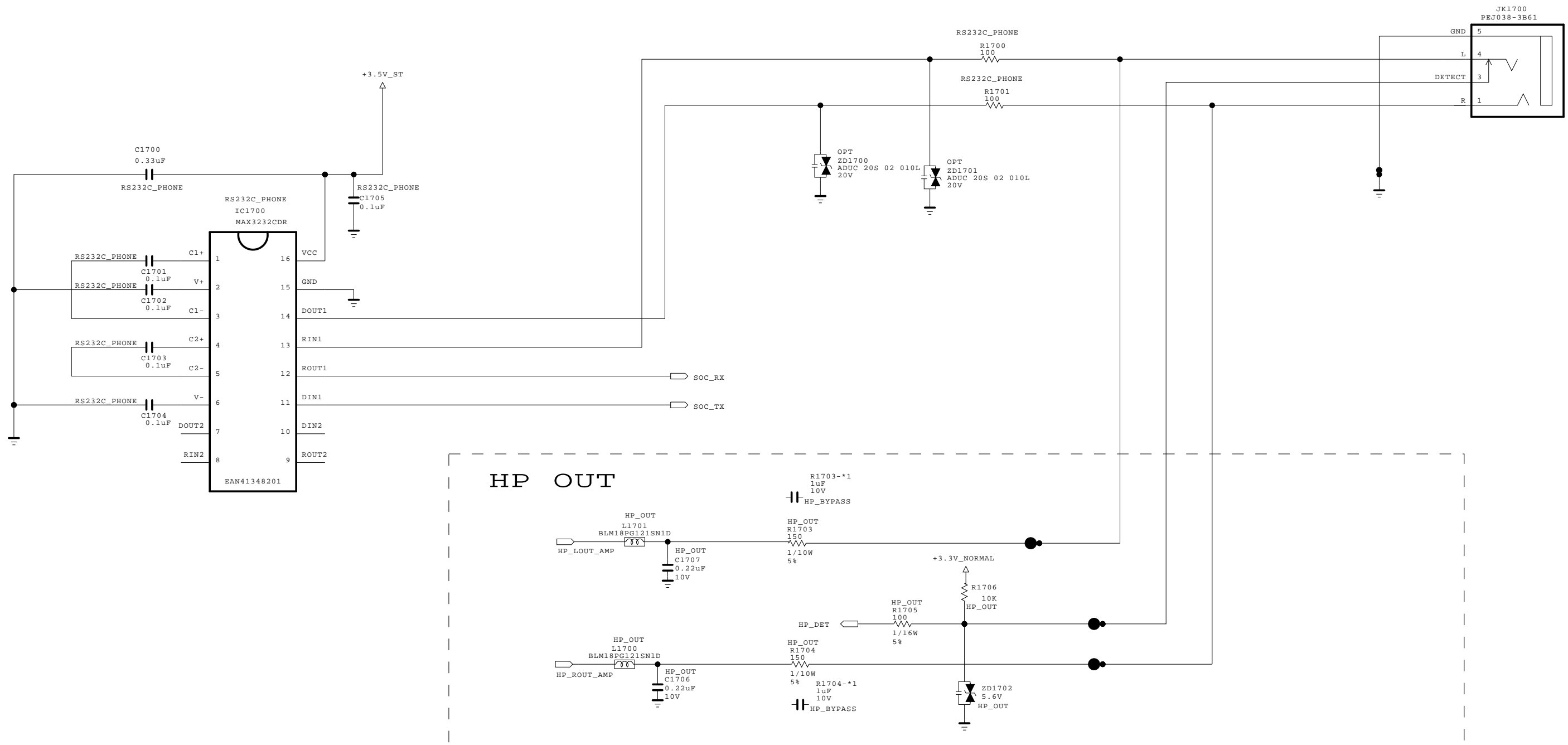

MODEL	UB83	DATE	2013-10-28
BLOCK	TU_SYMBOL	SHEET	16 /

# RS-232C Control INTERFACE



THE  SYMBOL MARK OF THIS SCHEMATIC DIAGRAM INCORPORATES SPECIAL FEATURES IMPORTANT FOR PROTECTION FROM X-RADIATION. FIRE AND ELECTRICAL SHOCK HAZARDS, WHEN SERVICING IF IS ESSENTIAL THAT ONLY MANUFACTURERS SPECIFIED PARTS BE USED FOR THE CRITICAL COMPONENTS IN THE  SYMBOL MARK OF THE SCHEMATIC.

SECRET	 LG ELECTRONICS
LGElectronics	

MODEL	UB83	DATE	2013-10-28
BLOCK	RS232C	SHEET	17 /



# DVB-S2 LNB Part Allegro

(Option: LNB)

3A Input trace widths should be sized to conduct at least 3A  
Output trace widths should be sized to conduct at least 2A

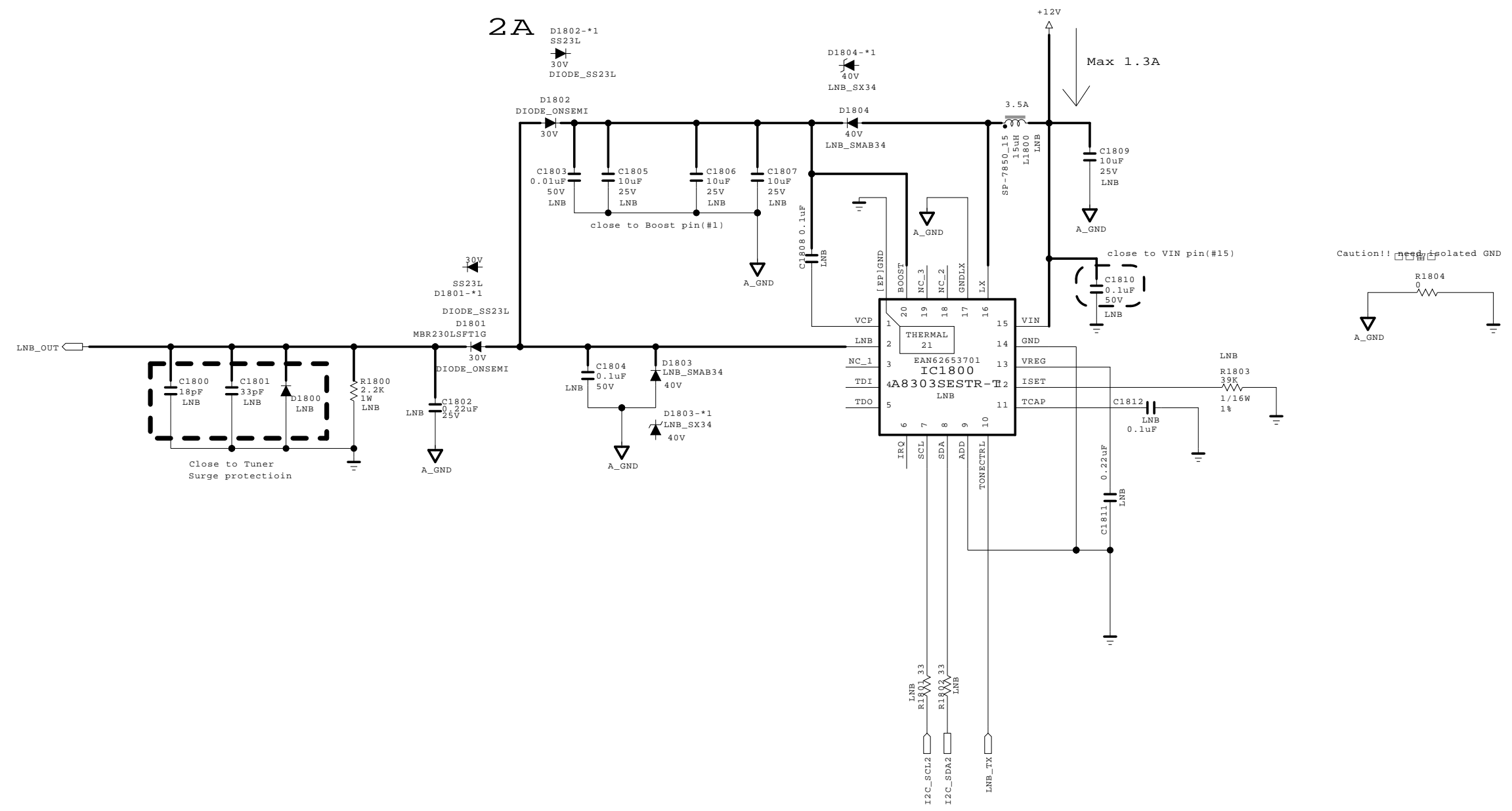

THE ⚠ SYMBOL MARK OF THIS SCHEMATIC DIAGRAM INCORPORATES SPECIAL FEATURES IMPORTANT FOR PROTECTION FROM X-RADIATION. FIRE AND ELECTRICAL SHOCK HAZARDS, WHEN SERVICING IT IS ESSENTIAL THAT ONLY MANUFACTURERS SPECIFIED PARTS BE USED FOR THE CRITICAL COMPONENTS IN THE ⚠ SYMBOL MARK OF THE SCHEMATIC.

SECRET	LG ELECTRONICS
LGElectronics	

MODEL	UB83	DATE	2013-10-28
BLOCK	LNB	SHEET	18 /

# eMMC I/F

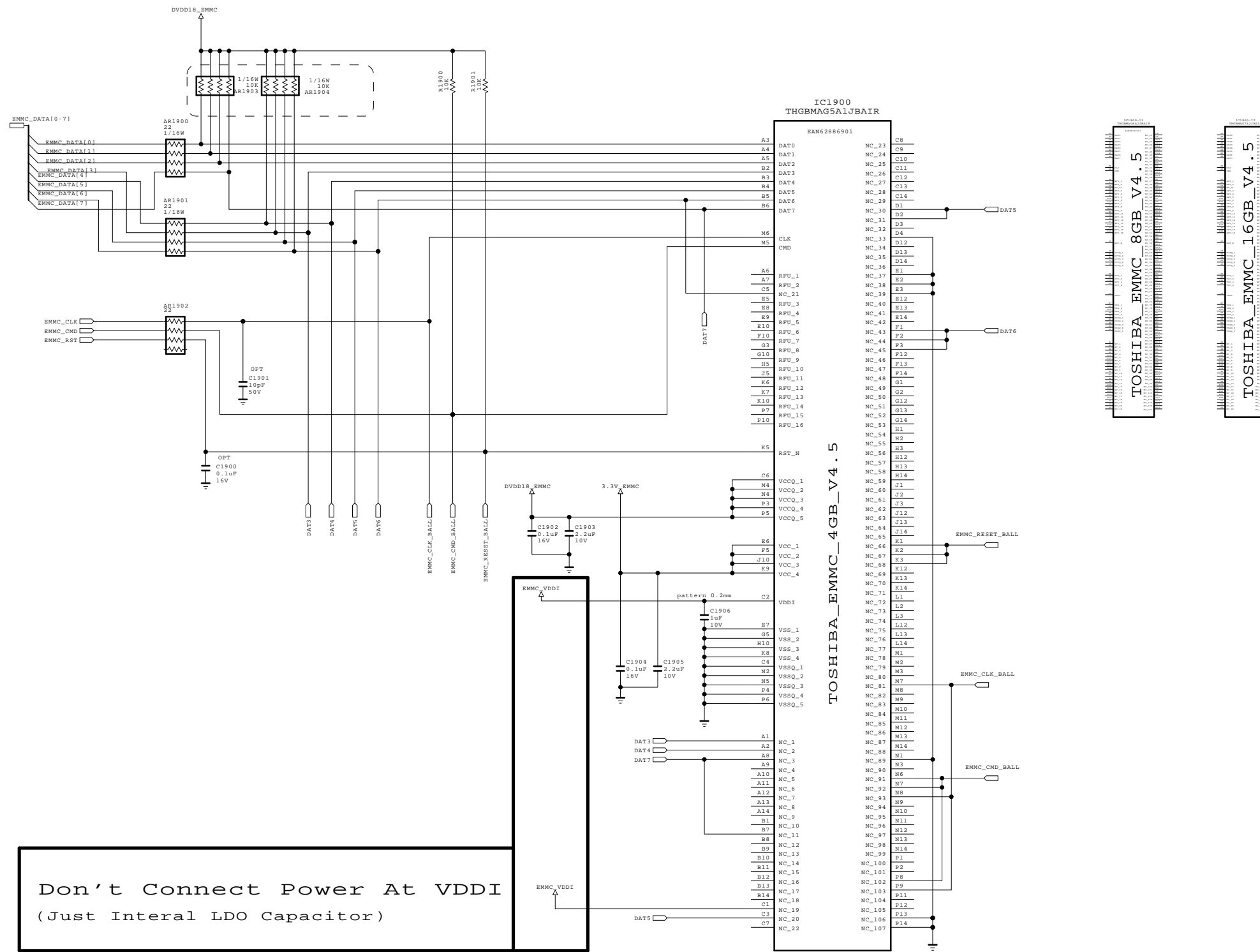

Don't Connect Power At VDDI  
(Just Interl LDO Capacitor)

THE SYMBOL MARK OF THIS SCHEMATIC DIAGRAM INCORPORATES SPECIAL FEATURES IMPORTANT FOR PROTECTION FROM X-RADIATION. FIRE AND ELECTRICAL SHOCK HAZARDS, WHEN SERVICING IF IS ESSENTIAL THAT ONLY MANUFACTURERS SPECIFIED PARTS BE USED FOR THE CRITICAL COMPONENTS IN THE SYMBOL MARK OF THE SCHEMATIC.

SECRET  
LGElectronics



MODEL	UB83	DATE	2013-10-28
BLOCK	EMMC	SHEET	19 /

## Full Scart (18 Pin Gender)

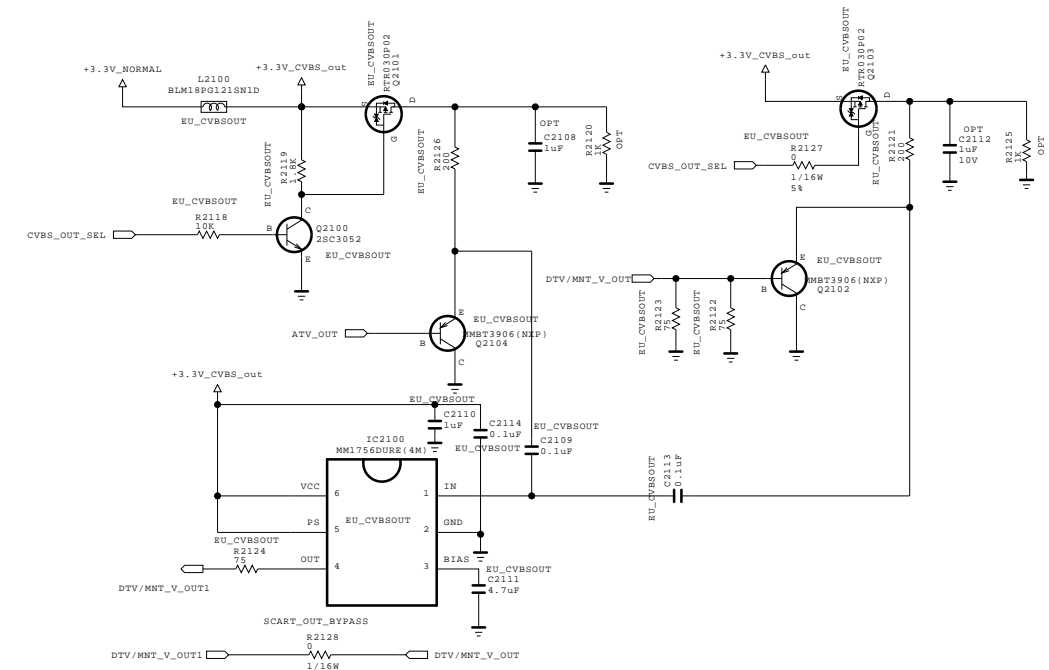
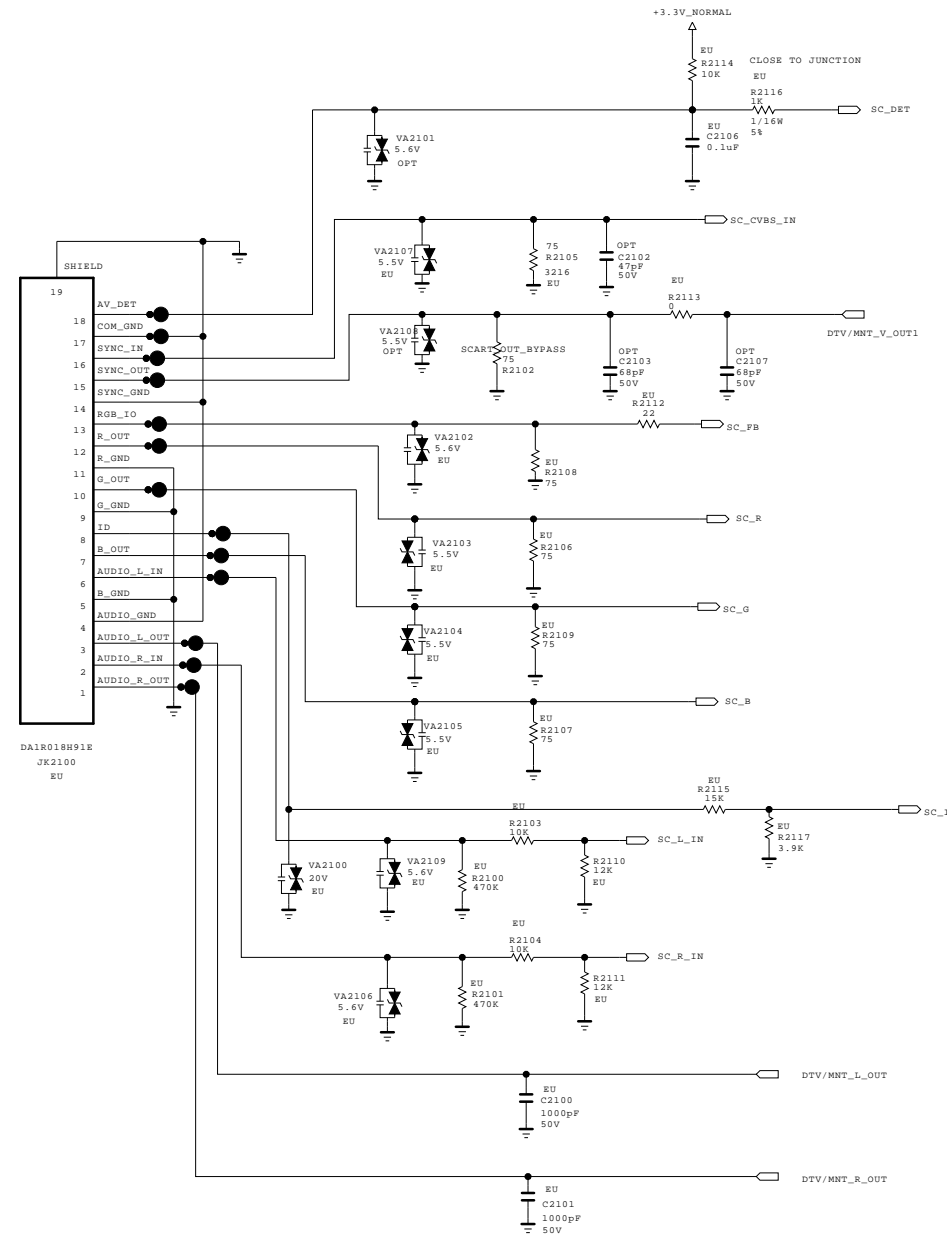

CVBS_OUT_SEL	0	1	
DTV_MNT_V_OUT1	DTV OUT	ATV OUT	

THE  $\Delta$  SYMBOL MARK OF THIS SCHEMATIC DIAGRAM INCORPORATES SPECIAL FEATURES IMPORTANT FOR PROTECTION FROM X-RADIATION. FIRE AND ELECTRICAL SHOCK HAZARDS, WHEN SERVICING IF IS ESSENTIAL THAT ONLY MANUFACTURERS SPECIFIED PARTS BE USED FOR THE CRITICAL COMPONENTS IN THE  $\Delta$  SYMBOL MARK OF THE SCHEMATIC.

**SECRET**  
LGElectronics



MODEL	UB83	DATE	2013-10-28
BLOCK	SCART JACK	SHEET	21 /

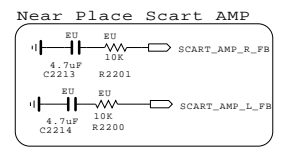
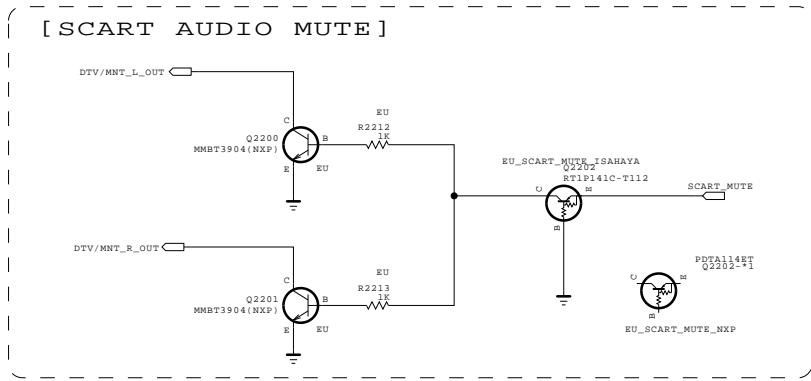
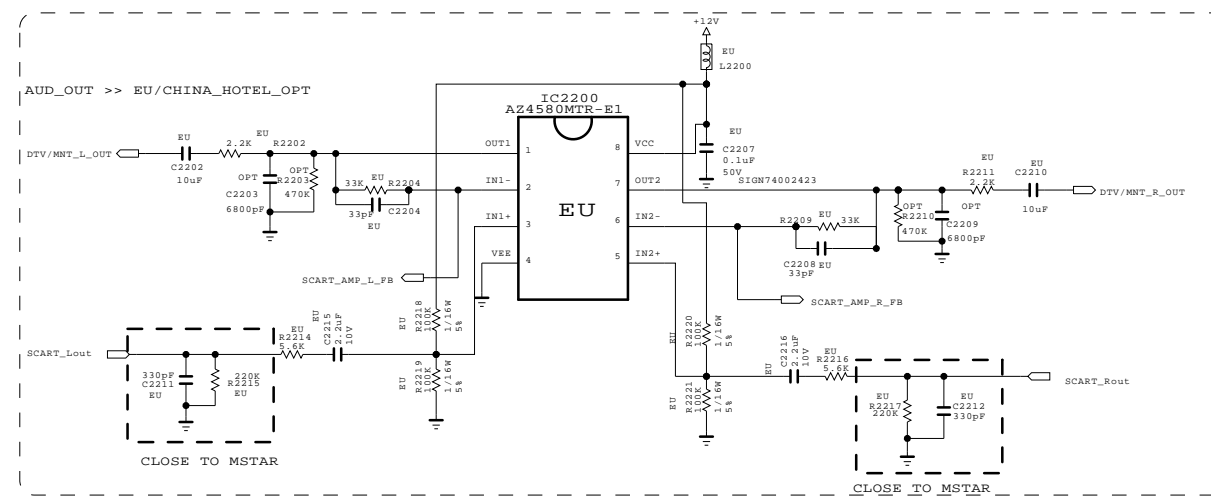

THE SYMBOL MARK OF THIS SCHEMATIC DIAGRAM INCORPORATES SPECIAL FEATURES IMPORTANT FOR PROTECTION FROM X-RADIATION. FIRE AND ELECTRICAL SHOCK HAZARDS, WHEN SERVICING IF IS ESSENTIAL THAT ONLY MANUFACTURERS SPECIFIED PARTS BE USED FOR THE CRITICAL COMPONENTS IN THE SYMBOL MARK OF THE SCHEMATIC.

**SECRET**  
LGElectronics



MODEL	UB83	DATE	2013-10-28
BLOCK	SCART JACK	SHEET	21 /

CI Region

\* Option name of this page : CI\_SLOT  
(because of Hong Kong)

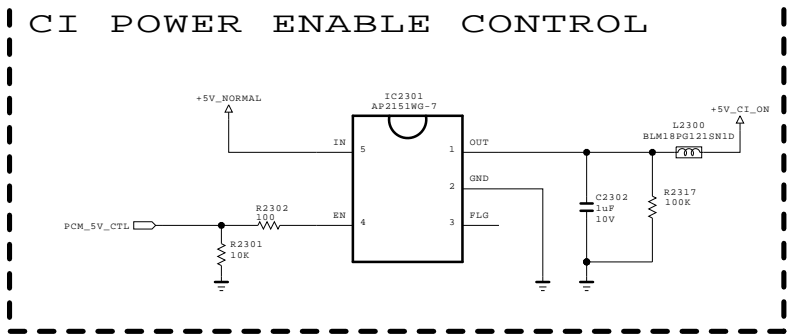
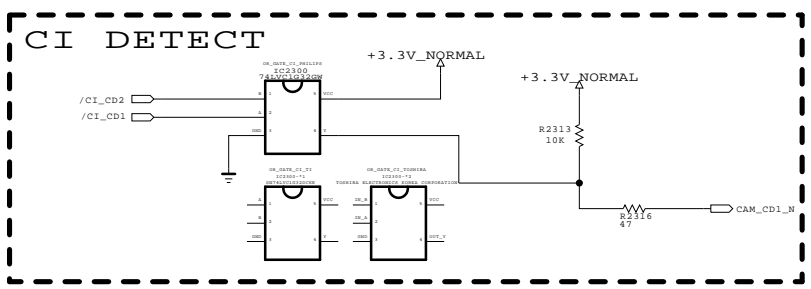
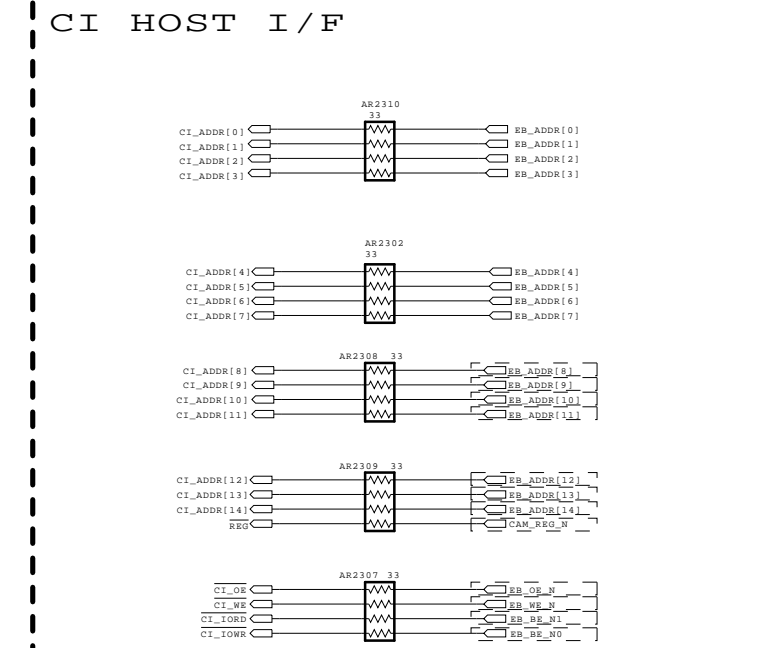
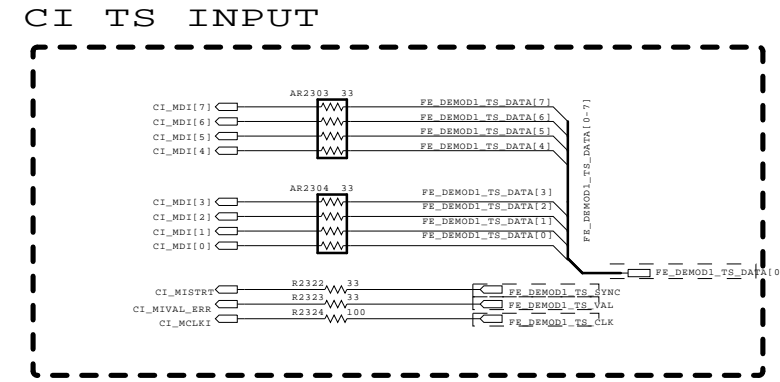
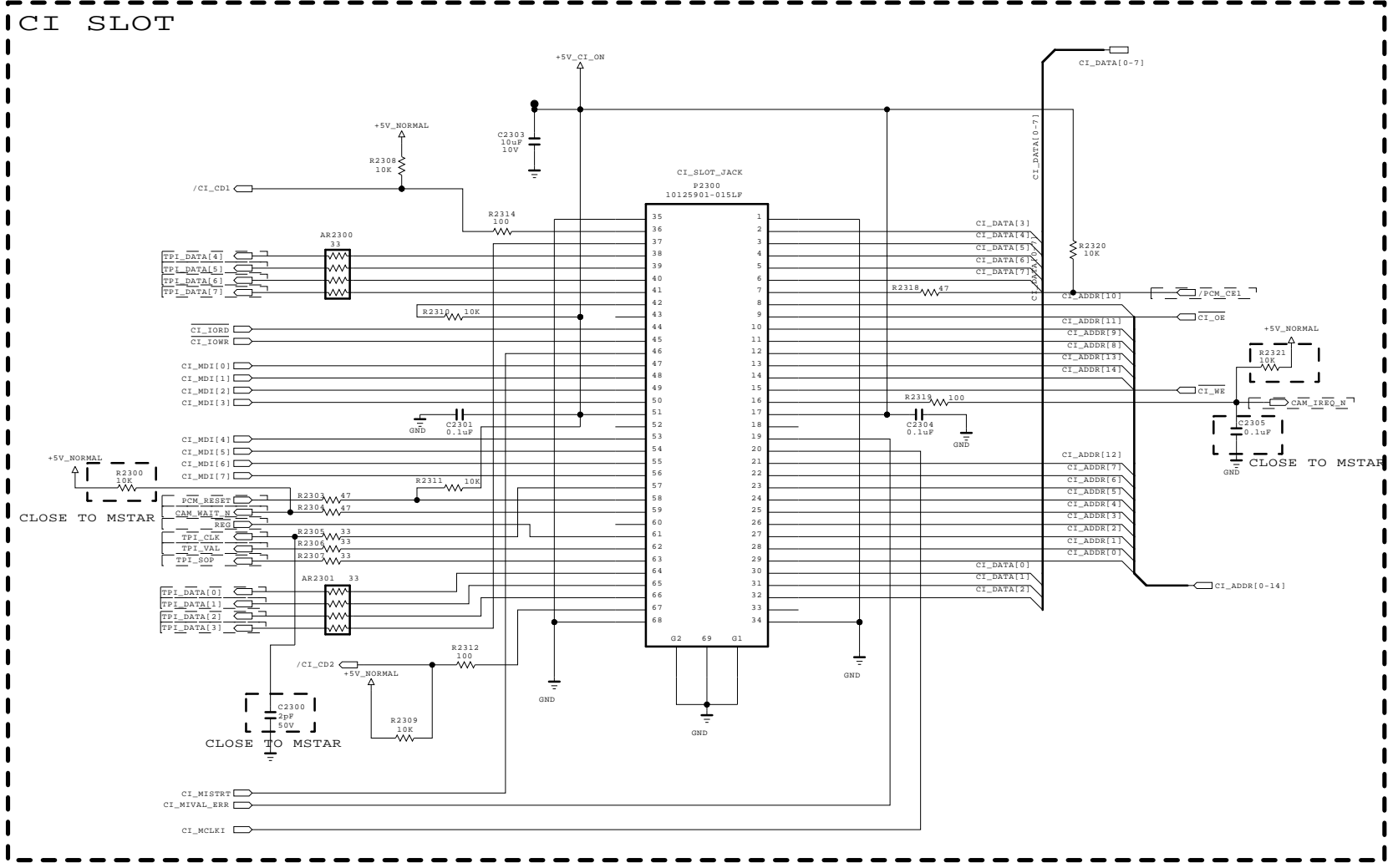

THE  $\Delta$  SYMBOL MARK OF THIS SCHEMATIC DIAGRAM INCORPORATES SPECIAL FEATURES IMPORTANT FOR PROTECTION FROM X-RADIATION. FIRE AND ELECTRICAL SHOCK HAZARDS, WHEN SERVICING IF IS ESSENTIAL THAT ONLY MANUFACTURERS SPECIFIED PARTS BE USED FOR THE CRITICAL COMPONENTS IN THE  $\Delta$  SYMBOL MARK OF THE SCHEMATIC.

SECRET  
LGElectronics



MODEL	NC5_M1A	DATE	2013.04.29
BLOCK	PCMC1	SHEET	19

IC2500  
LGE7411(URSA9)

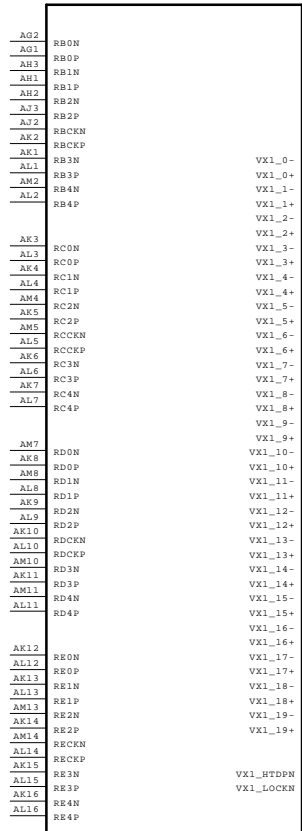

IC2500  
LGE7411(URSA9)

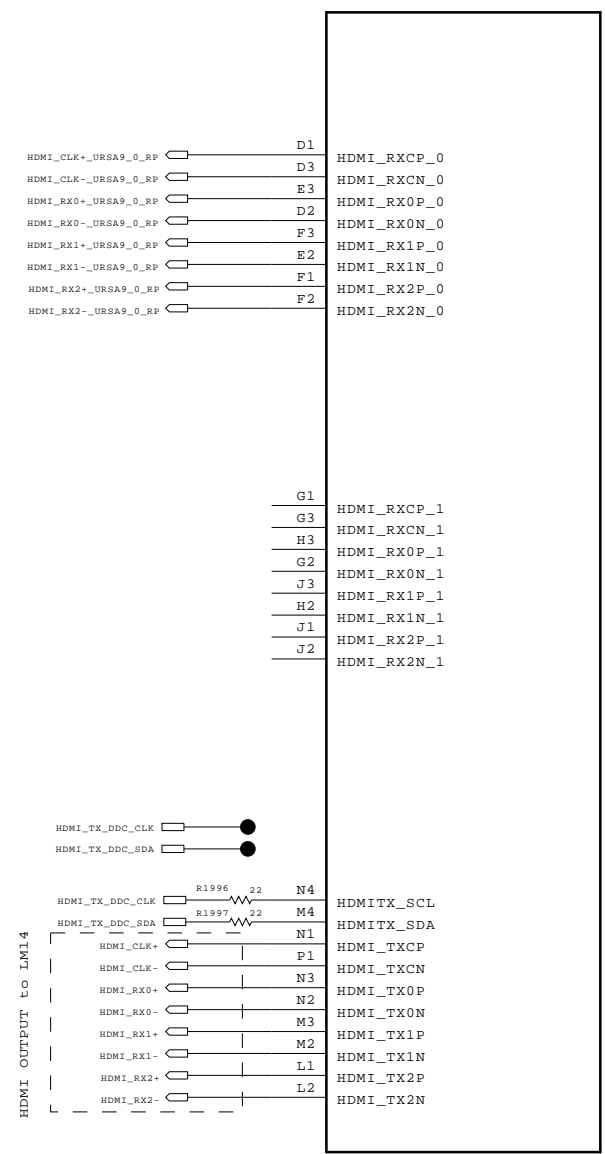

GND Connection at Vx1 41pin wafer

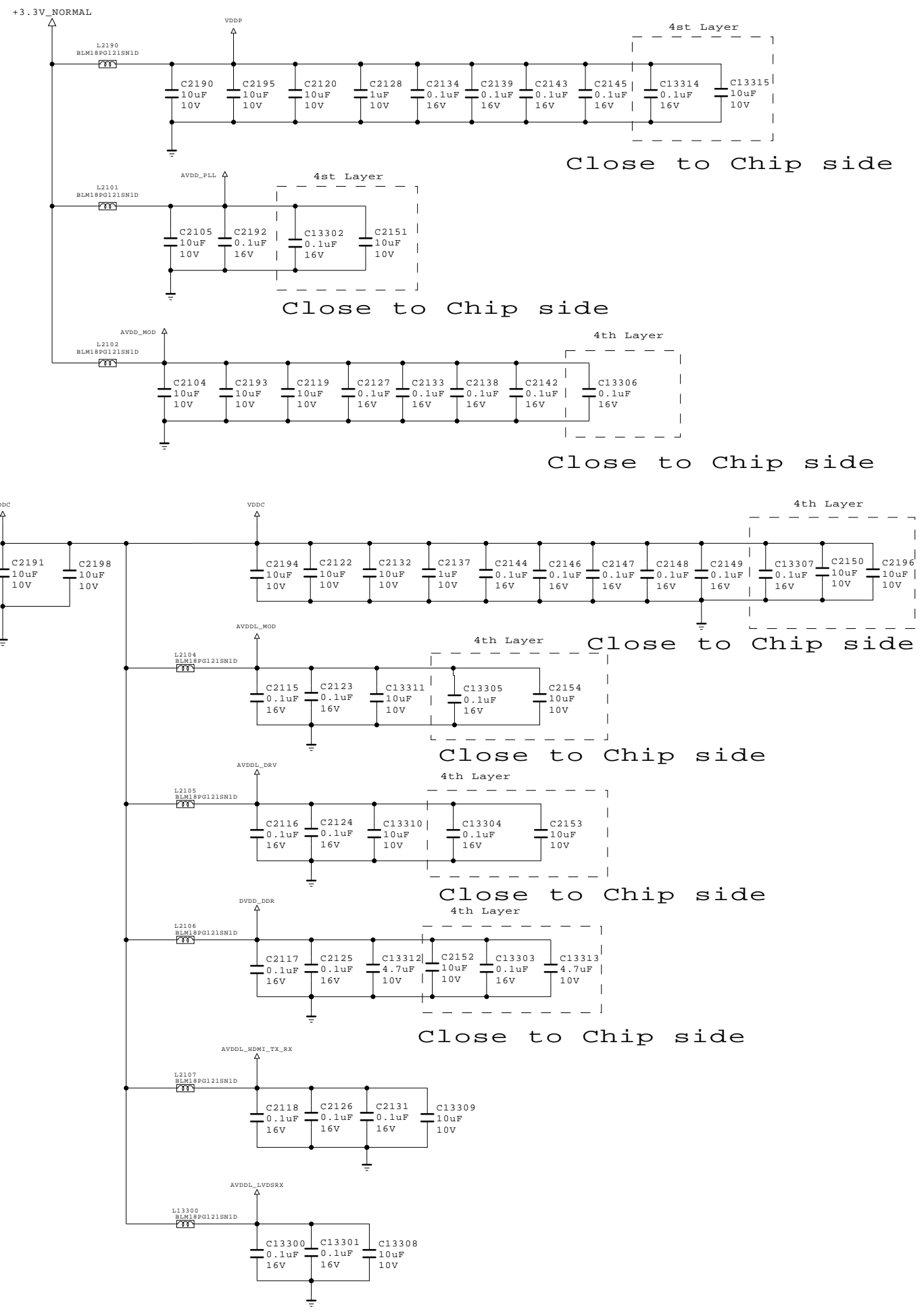
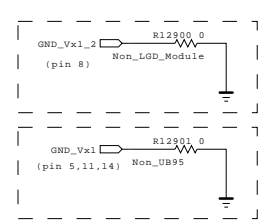

THE  $\Delta$  SYMBOL MARK OF THIS SCHEMATIC DIAGRAM INCORPORATES SPECIAL FEATURES IMPORTANT FOR PROTECTION FROM X-RADIATION. FIRE AND ELECTRICAL SHOCK HAZARDS, WHEN SERVICING IF IS ESSENTIAL THAT ONLY MANUFACTURERS SPECIFIED PARTS BE USED FOR THE CRITICAL COMPONENTS IN THE  $\Delta$  SYMBOL MARK OF THE SCHEMATIC.

SECRET  
LGElectronics



MODEL	DATE	2013.12.17
BLOCK	U_LVDS INPUT	SHEET

BSD-14Y-UD-128-02-HD

[ 51P Vx1 output wafer ]

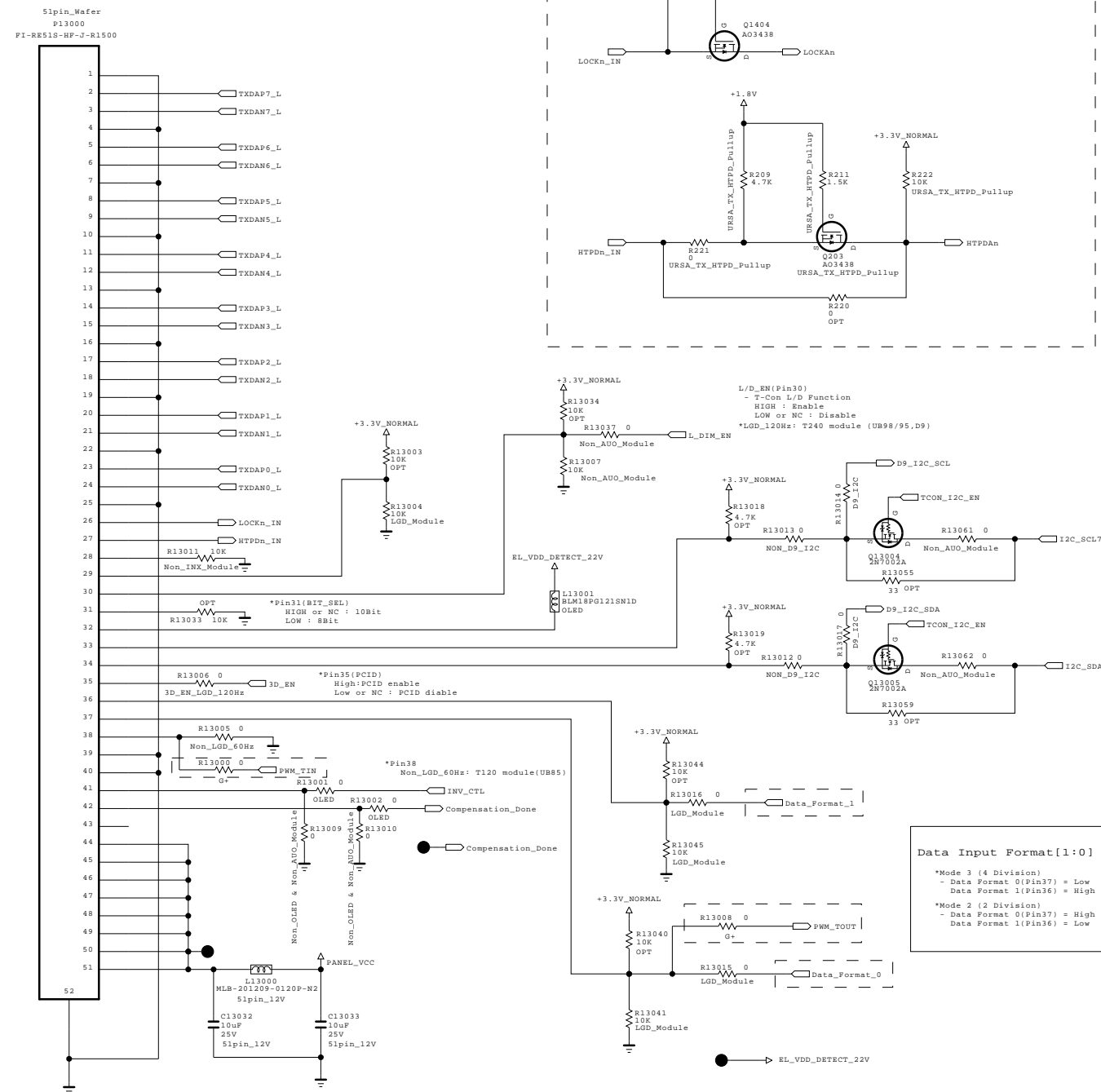

[ 41P Vx1 output wafer ]

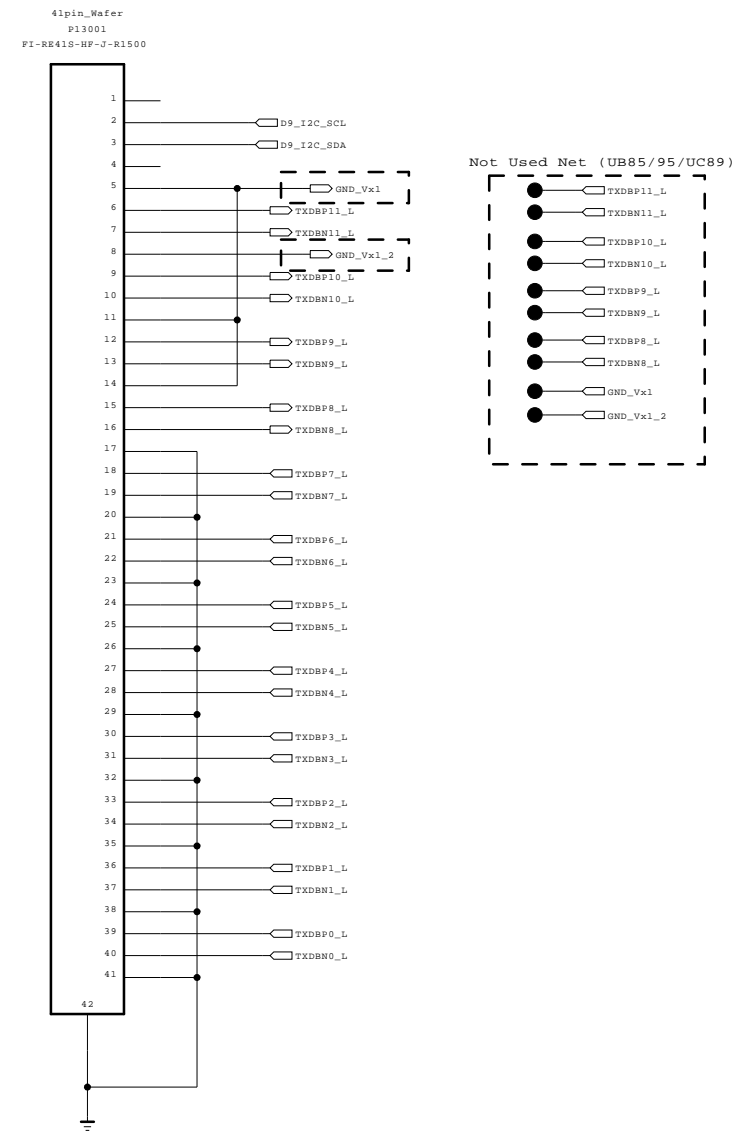

THE SYMBOL MARK OF THIS SCHEMATIC DIAGRAM INCORPORATES SPECIAL FEATURES IMPORTANT FOR PROTECTION FROM X-RADIATION. FIRE AND ELECTRICAL SHOCK HAZARDS, WHEN SERVICING IF IS ESSENTIAL THAT ONLY MANUFACTURERS SPECIFIED PARTS BE USED FOR THE CRITICAL COMPONENTS IN THE SYMBOL MARK OF THE SCHEMATIC.

SECRET  
LGElectronics



MODEL		DATE	2013.12.17
BLOCK	Output_wafer	SHEET	/

BSD-14Y-UD-130-HD

IC2500  
LGE7411 (URSA9)

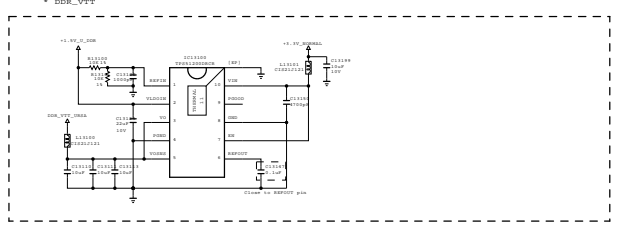
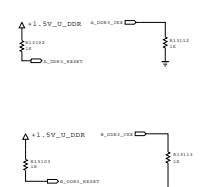
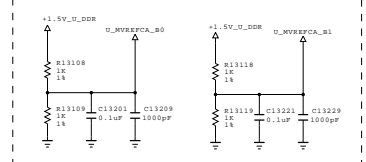
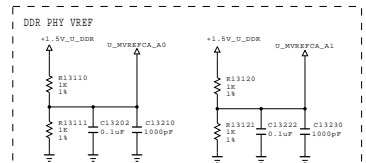
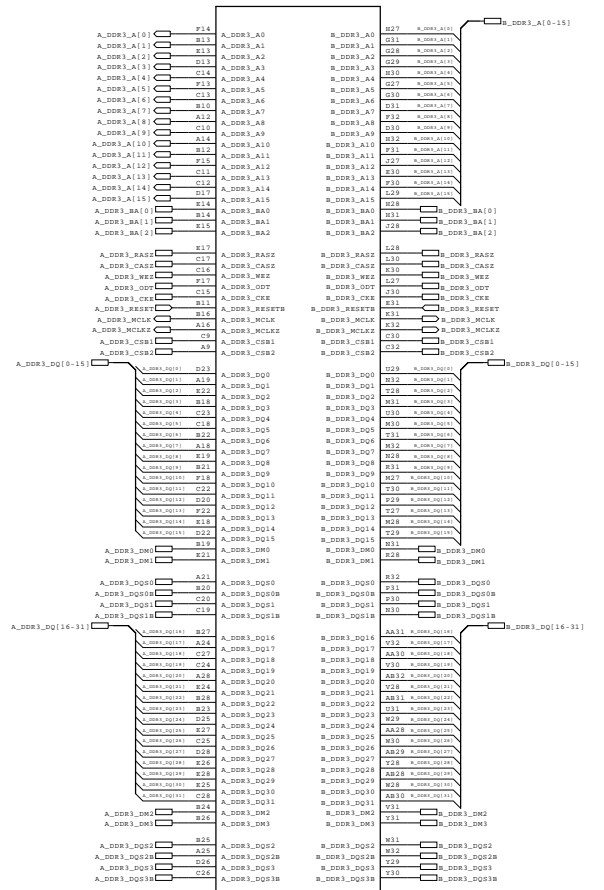

Decap removed

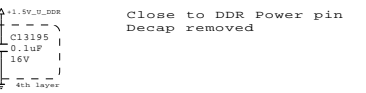
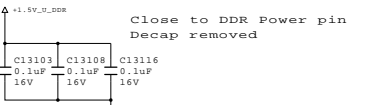
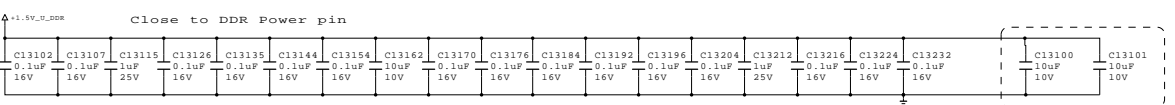
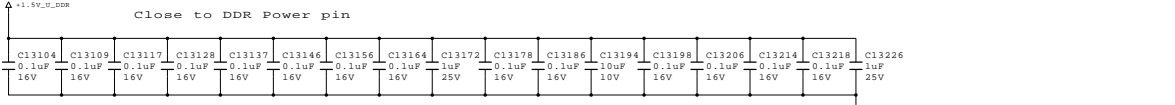

IC2600  
H5TQ1G63EPR-RDC

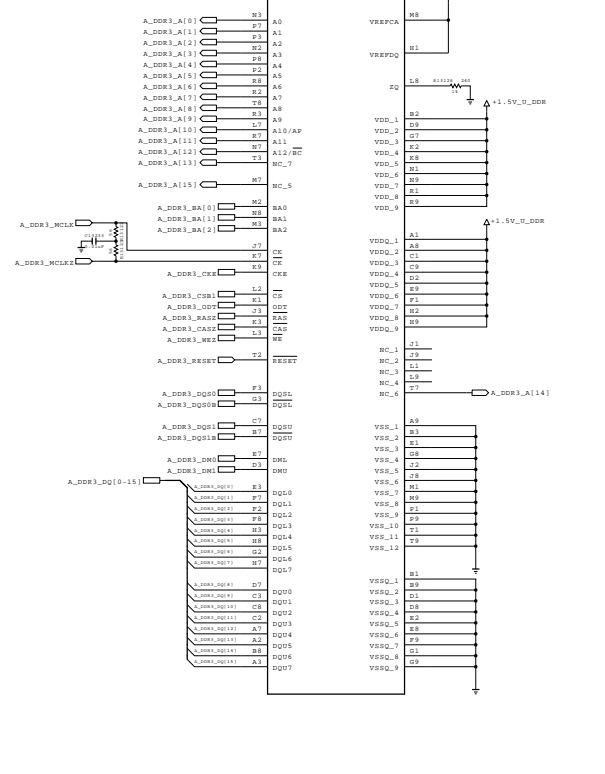

IC2700  
H5TQ1G63EPR-RDC

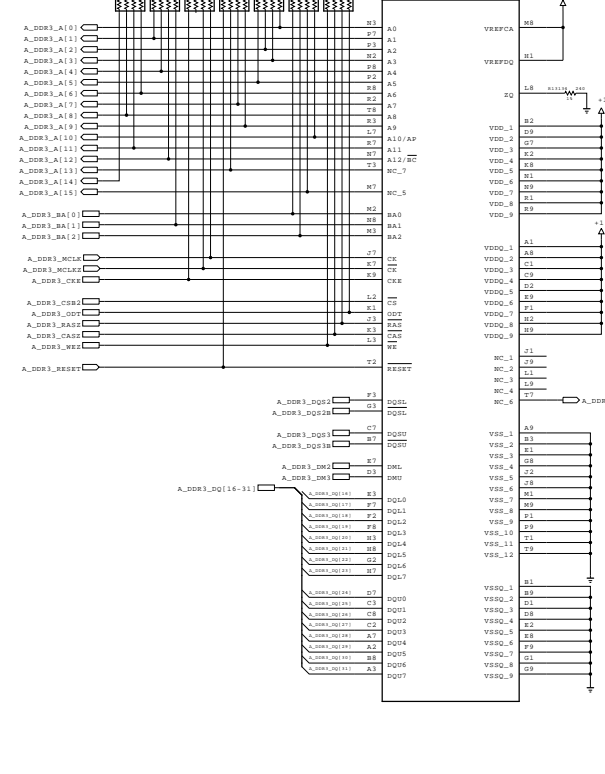

IC2800  
H5TQ1G63EPR-RDC

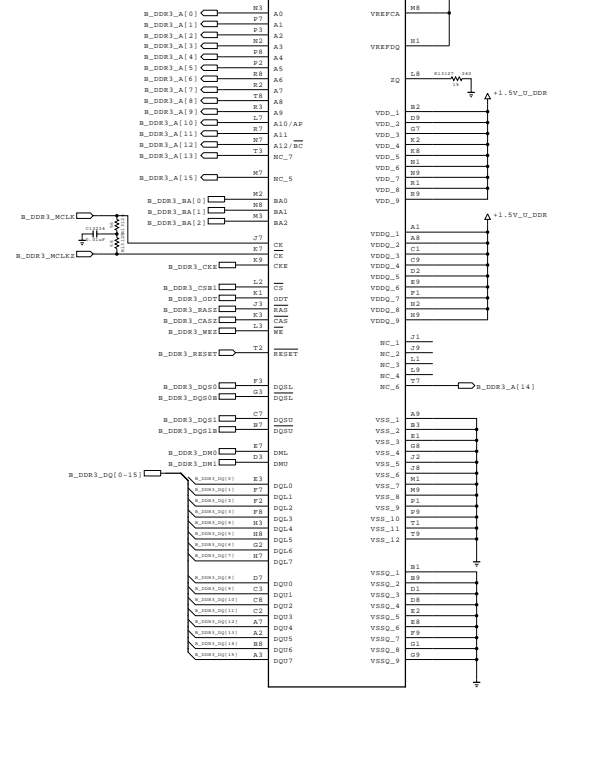

IC2900  
H5TQ1G63EPR-RDC

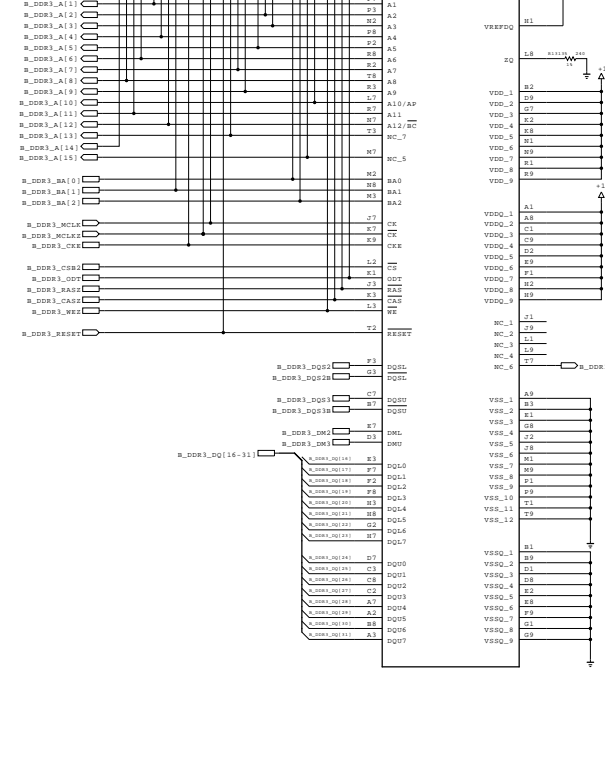

SECRET  
LGElectronics LG ELECTRONICS

MODEL: URSA7\_DDR  
DATE: 2013.12.17  
BLOCK: SHEET



### Clock for URSA9

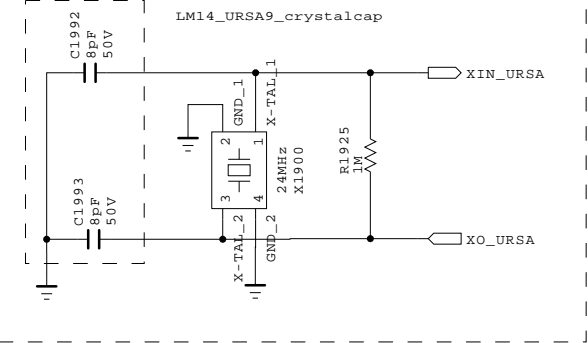

### URSA Reset

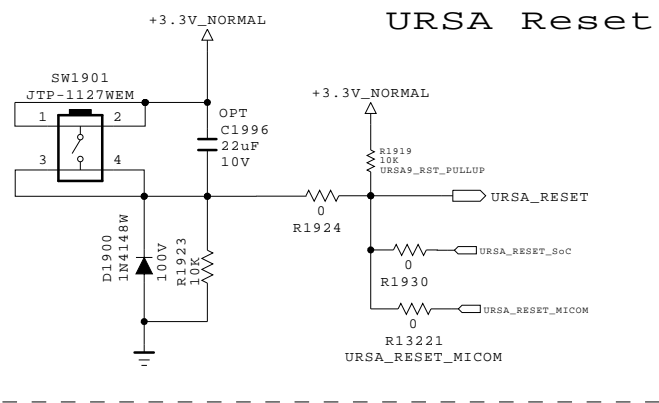

### URSA9 Option

BIT [1/0]	Module Division
0/0	Non Division
0/1	2 Division
1/0	4 Division
1/1	8 Division

BIT [2/1/0]	Tx Lane
0/0/0	4Kx120 (16lane)
0/0/1	4Kx60 (8lane)
0/1/0	5Kx120 (20lane)
0/1/1	OLED ULTRA HD
1/0/0	PHDx120 (4lane)
1/0/1	PHDx60 (2lane)
1/1/0	Reserved
1/1/1	Reserved

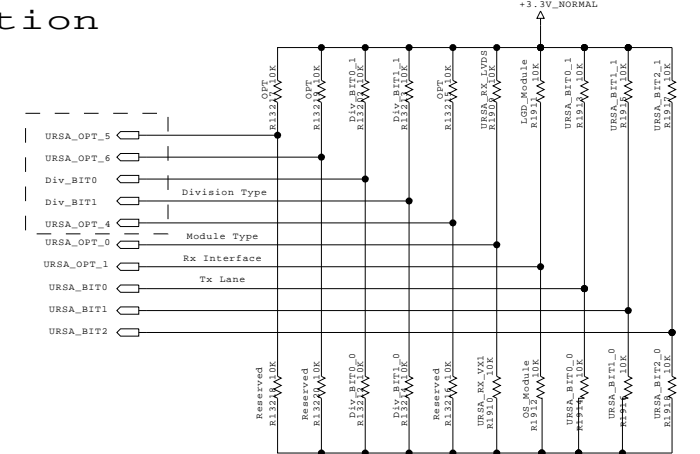

### IC2500 LGE7411 (URSA9)

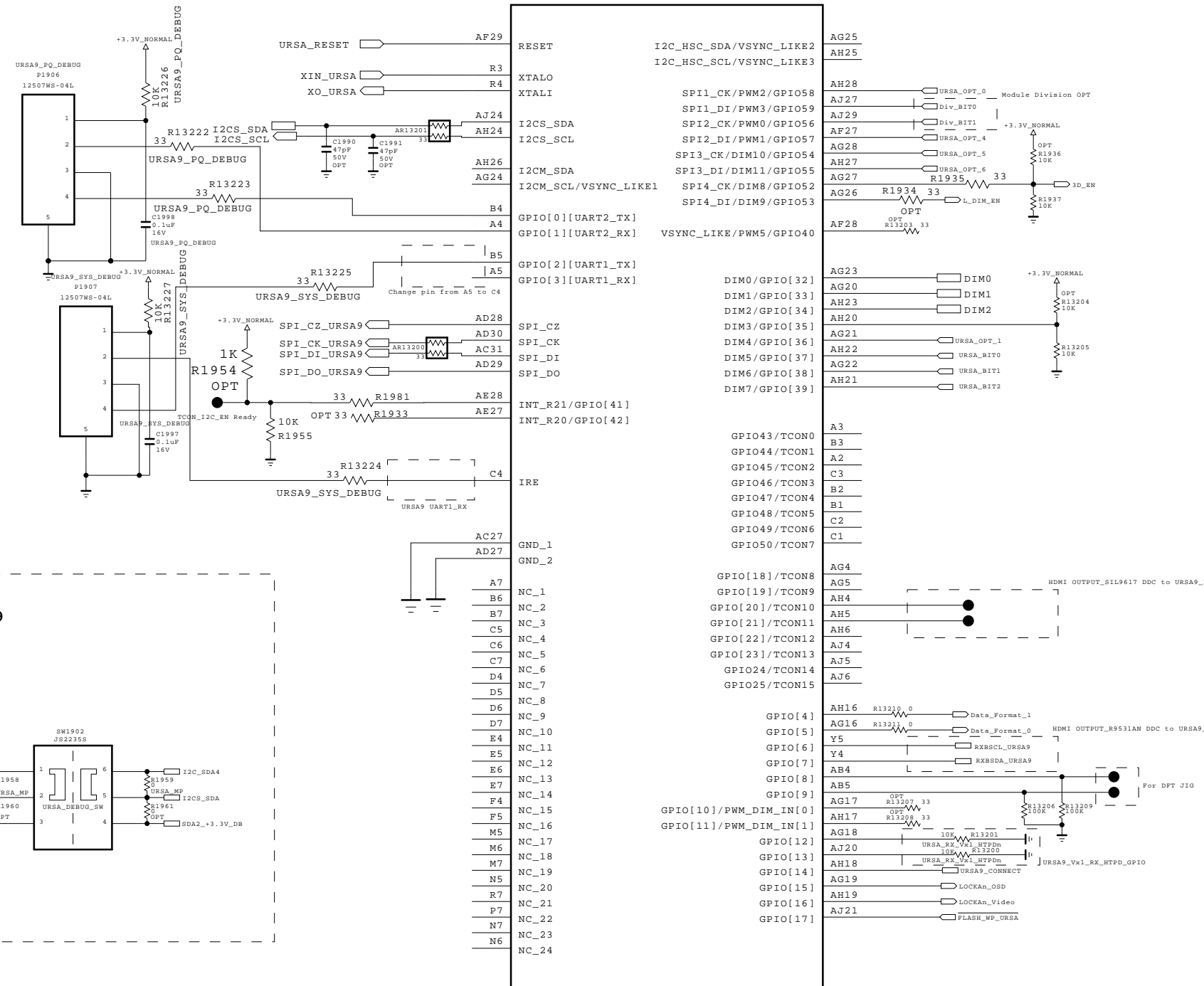

### SPI Flash

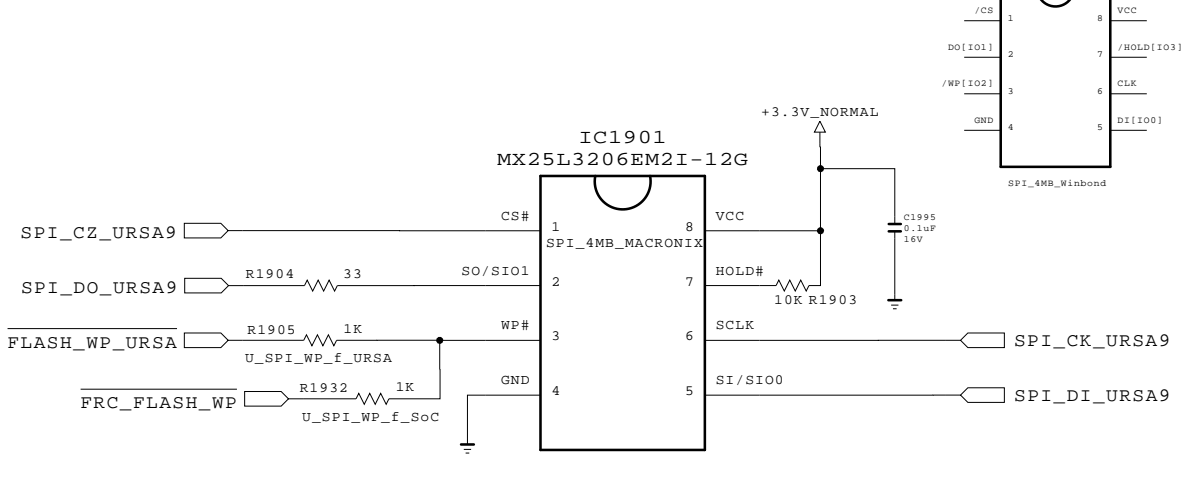

### Chip Config

Debug/ISP ADDR  
 Slave (Debug Port: 0XB4, ISP: 0X98)  
 CHIP\_CONF: {DIM2, DIM1, DIM0}  
 CHIP\_CONF=3'd7:111:boot from SPI Flash

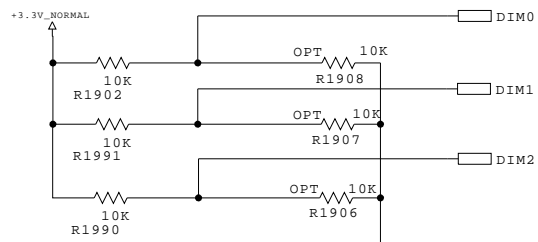

### Debugging for URSA9

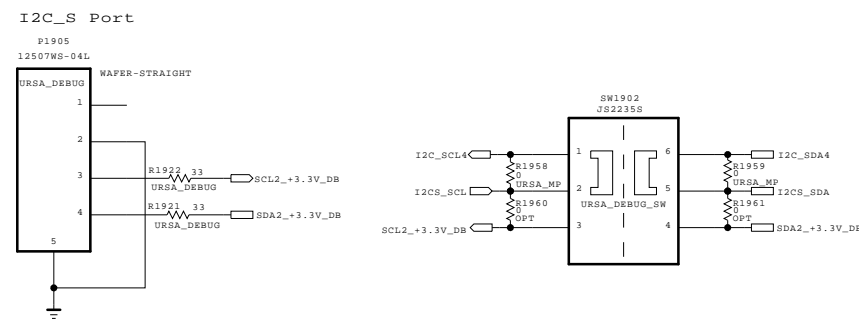

THE  $\Delta$  SYMBOL MARK OF THIS SCHEMATIC DIAGRAM INCORPORATES SPECIAL FEATURES IMPORTANT FOR PROTECTION FROM X-RADIATION. FIRE AND ELECTRICAL SHOCK HAZARDS, WHEN SERVICING IF IS ESSENTIAL THAT ONLY MANUFACTURERS SPECIFIED PARTS BE USED FOR THE CRITICAL COMPONENTS IN THE  $\Delta$  SYMBOL MARK OF THE SCHEMATIC.

SECRET  
 LGElectronics



MODEL		DATE	2013.12.17
BLOCK		SHEET	/

BSD-14Y-UD-132-HD

IC2500  
LGE7411 (URSA9)

IC2500  
LGE7411 (URSA9)

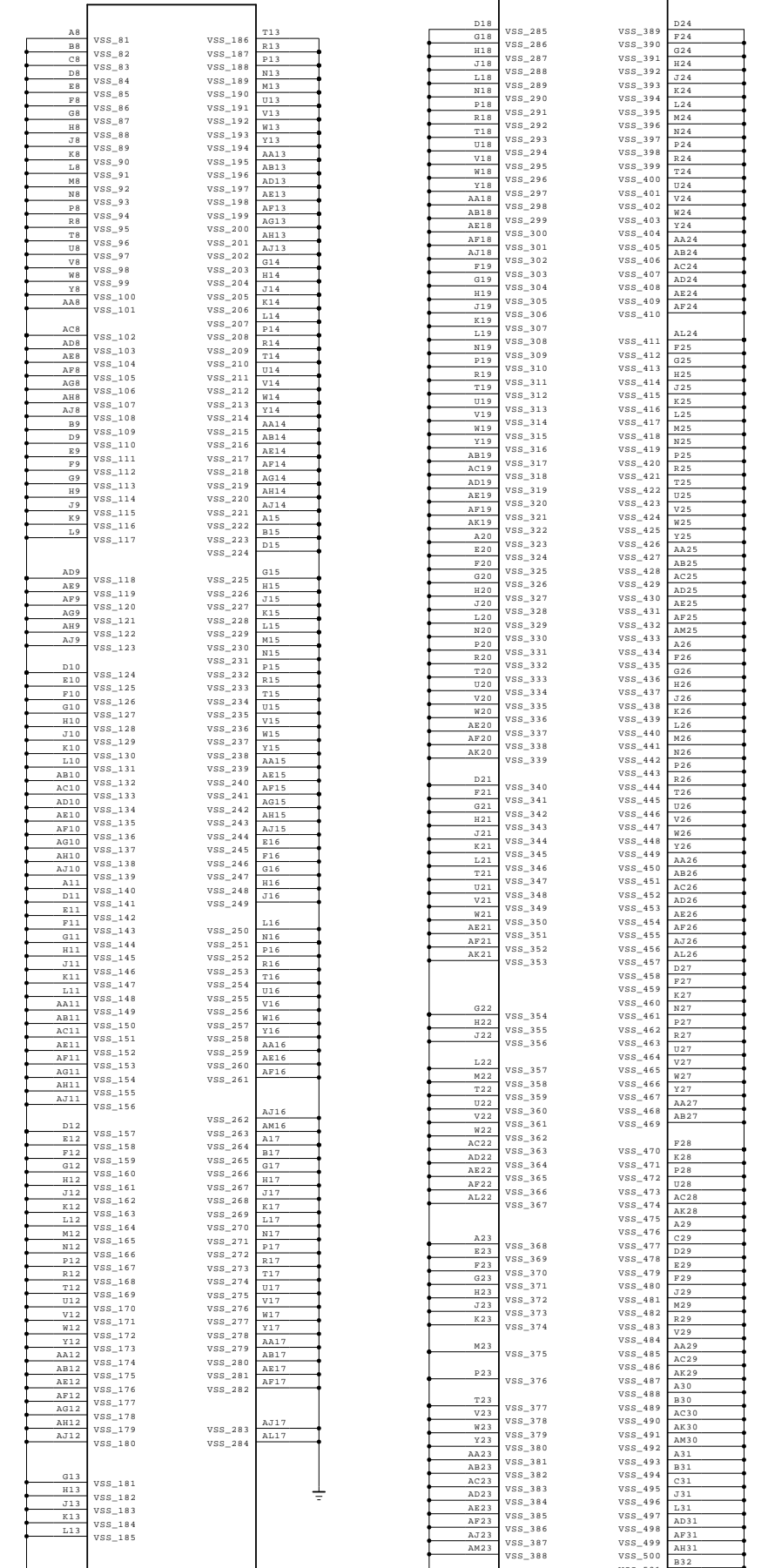
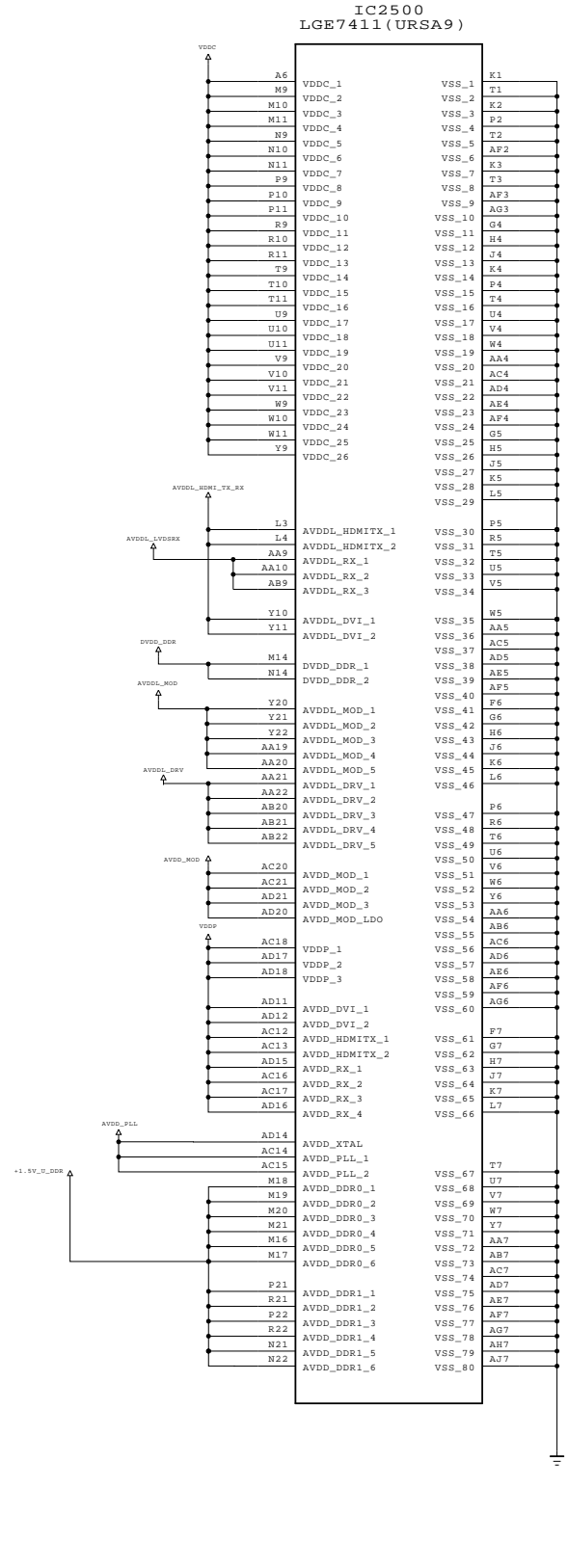

THE SYMBOL MARK OF THIS SCHEMATIC DIAGRAM INCORPORATES SPECIAL FEATURES IMPORTANT FOR PROTECTION FROM X-RADIATION. FIRE AND ELECTRICAL SHOCK HAZARDS, WHEN SERVICING IF IS ESSENTIAL THAT ONLY MANUFACTURERS SPECIFIED PARTS BE USED FOR THE CRITICAL COMPONENTS IN THE SYMBOL MARK OF THE SCHEMATIC.

SECRET  
LGElectronics



MODEL	U_Power	DATE	2013.12.17
BLOCK		SHEET	

BSD-14Y-UD-133-HD

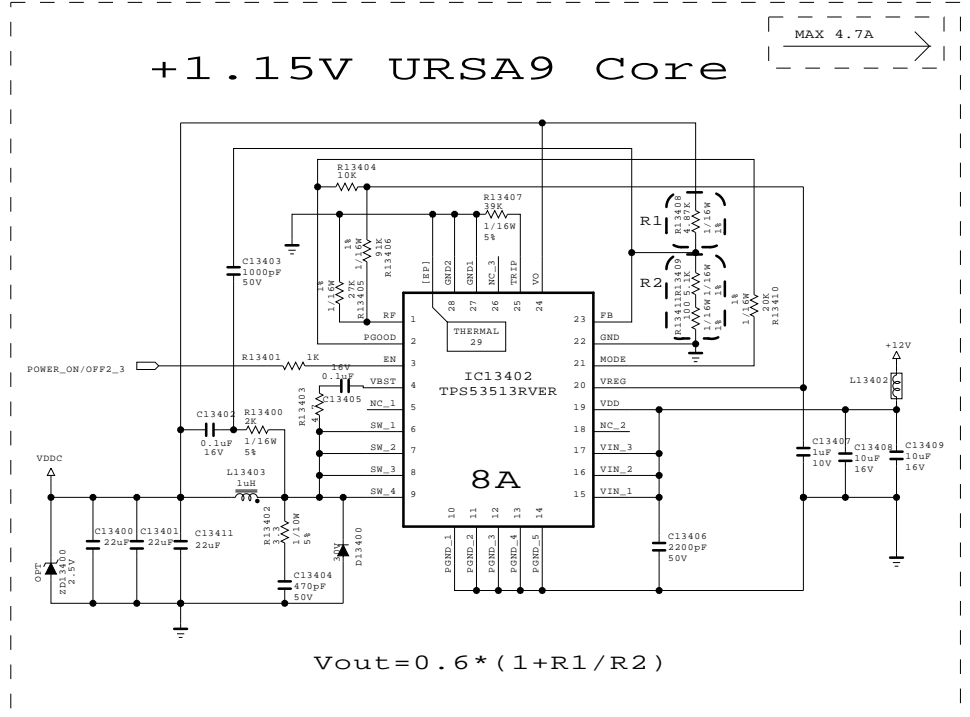
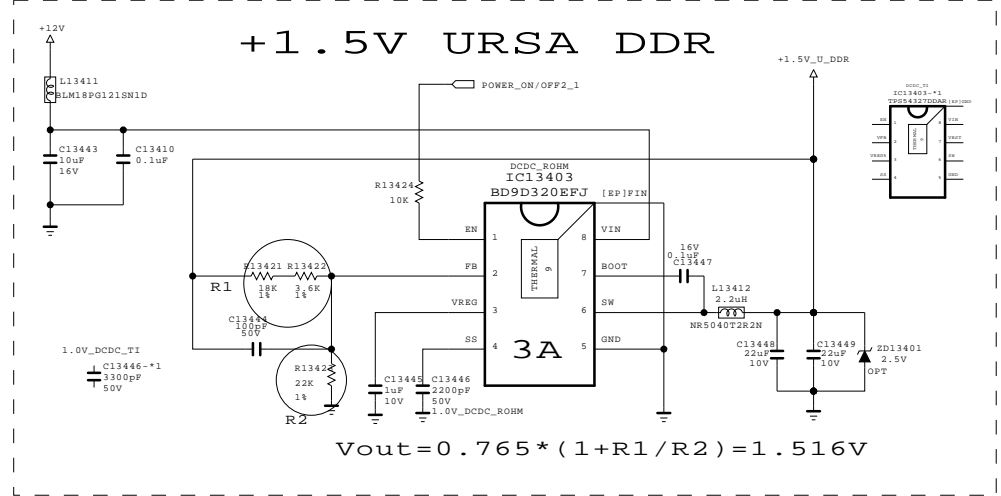
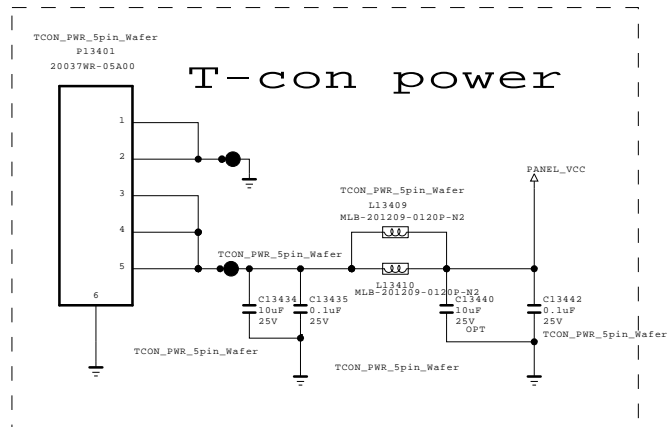

THE  $\Delta$  SYMBOL MARK OF THIS SCHEMATIC DIAGRAM INCORPORATES SPECIAL FEATURES IMPORTANT FOR PROTECTION FROM X-RADIATION. FIRE AND ELECTRICAL SHOCK HAZARDS, WHEN SERVICING IF IS ESSENTIAL THAT ONLY MANUFACTURERS SPECIFIED PARTS BE USED FOR THE CRITICAL COMPONENTS IN THE  $\Delta$  SYMBOL MARK OF THE SCHEMATIC.

SECRET  
LGElectronics



MODEL		DATE	2013.12.17
BLOCK		SHEET	/

BSD-14Y-UD-134-HD



# Contents of LCD TV Standard Repair Process

No.	Error symptom (High category)	Error symptom (Mid category)	Page	Remarks
1	A. Video error	No video/Normal audio	1	
2		No video/No audio	2	
3		Picture broken/ Freezing	3	
4		Color error	4	
5		Vertical/Horizontal bar, residual image, light spot, external device color error	5	
6	B. Power error	No power	6	
7		Off when on, off while viewing, power auto on/off	7	
8	C. Audio error	No audio/Normal video	8	
9		Wrecked audio/discontinuation/noise	9	
10	D. Function error	Remote control & Local switch checking	10	
11		MR(Magic Remocon) operating checking	11	
12		Wifi operating checking	12	
13		External device recognition error	13	
145	E. Noise	Circuit noise, mechanical noise	14	
15	F. Exterior error	Exterior defect	15	

First of all, Check whether there is SVC Bulletin in GCSC System for these model.

LCD TV	Error symptom	A. Video error	Established date	2013.01.31	
		No video/ Normal audio	Revised date		1/16

**First of all, Check whether all of cables between board is inserted properly or not.  
(Main B/D↔ Power B/D, LVDS Cable, Speaker Cable, IR B/D Cable,,)**

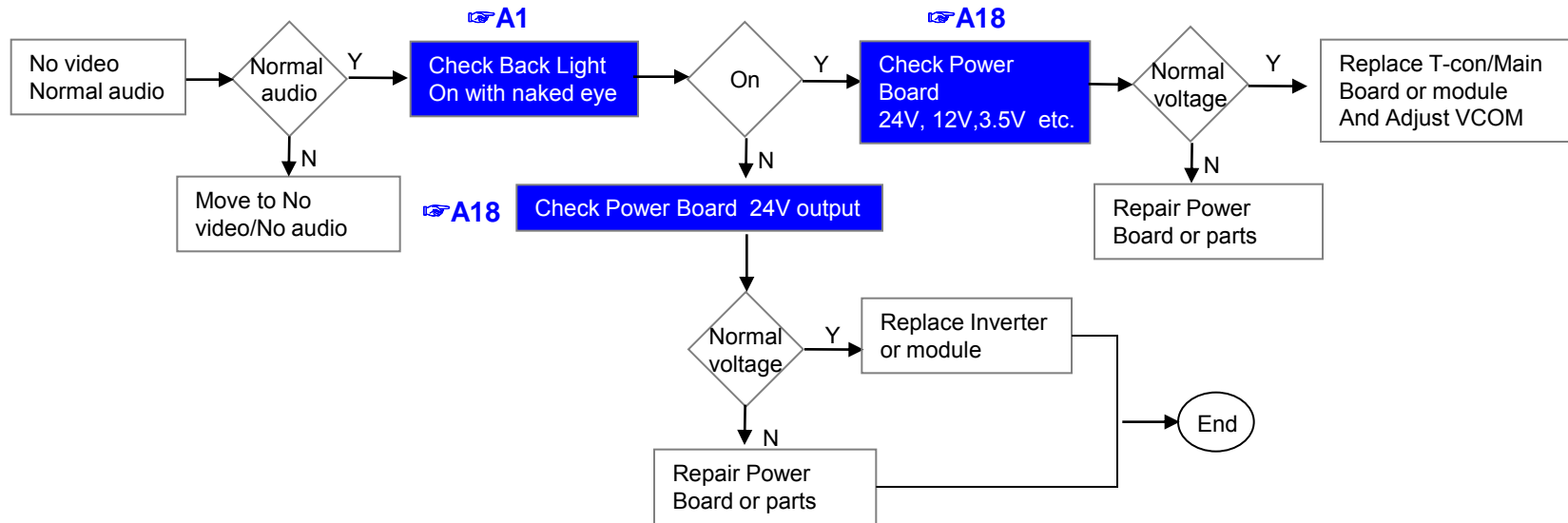

※Precaution A4 & A2



LCD TV	Error symptom	A. Video error	Established date	2013.01.31	
		No video/ No audio	Revised date		2/16

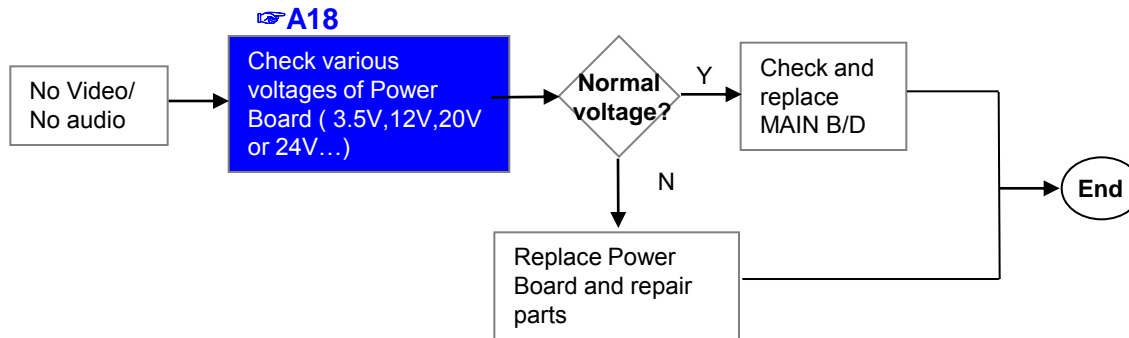

LCD TV	Error symptom	A. Video error	Established date	2013.01.31	
		Picture broken/ Freezing	Revised date		3/16

**A3**

**Check RF Signal level**

- . By using Digital signal level meter
- . By using Diagnostics menu on OSD  
( Setting → Support → Signal Test )
- Signal strength (Normal : over 50%)
- Signal Quality (Normal: over 50%)

Normal Signal?

Y → Check whether other equipments have problem or not.  
(By connecting RF Cable at other equipment  
→ DVD Player ,Set-Top-Box, Different maker TV etc`

Check RF Cable Connection  
1. Reconnection  
2. Install Booster

Normal Picture?

N → Contact with signal distributor or broadcaster (Cable or Air)

**A4**

**Check S/W Version**

Normal Picture?

SVC Bulletin?

S/W Upgrade

Normal Picture?

Check Tuner soldering

Close

Close

Close

Replace Main B/D



LCD TV	Error symptom	A. Video error	Established date	2013.01.31	
		Color error	Revised date		4/16

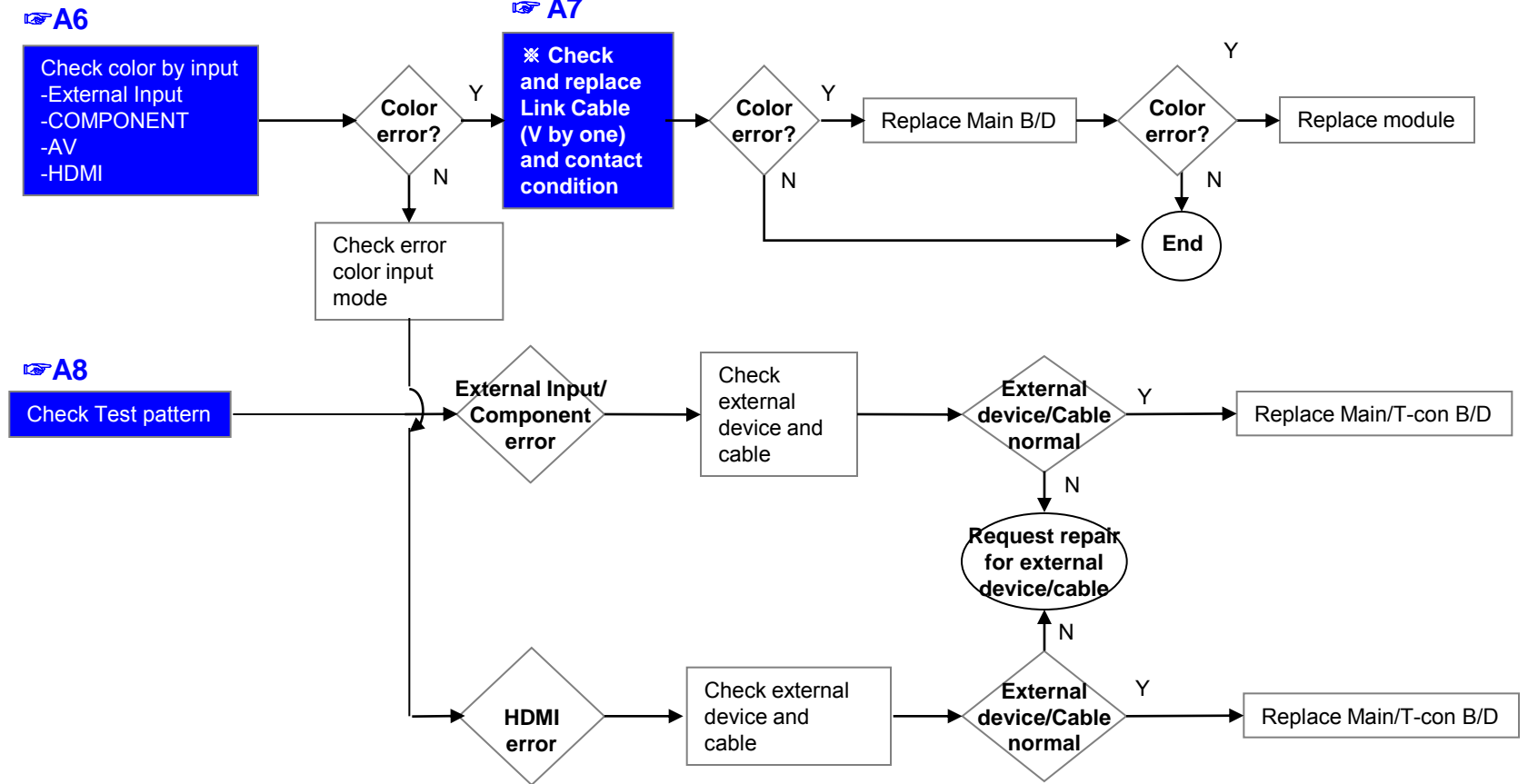

LCD TV	Error symptom	<b>A. Video error</b>	Established date	2013.01.31	
		Vertical / Horizontal bar, residual image, light spot, external device color error	Revised date		5/16

### Vertical/Horizontal bar, residual image, light spot

**A6**

Check color condition by input  
 -External Input  
 -Component  
 -HDMI

**A8**

Check Test pattern

**A7**

Check and replace Link Cable

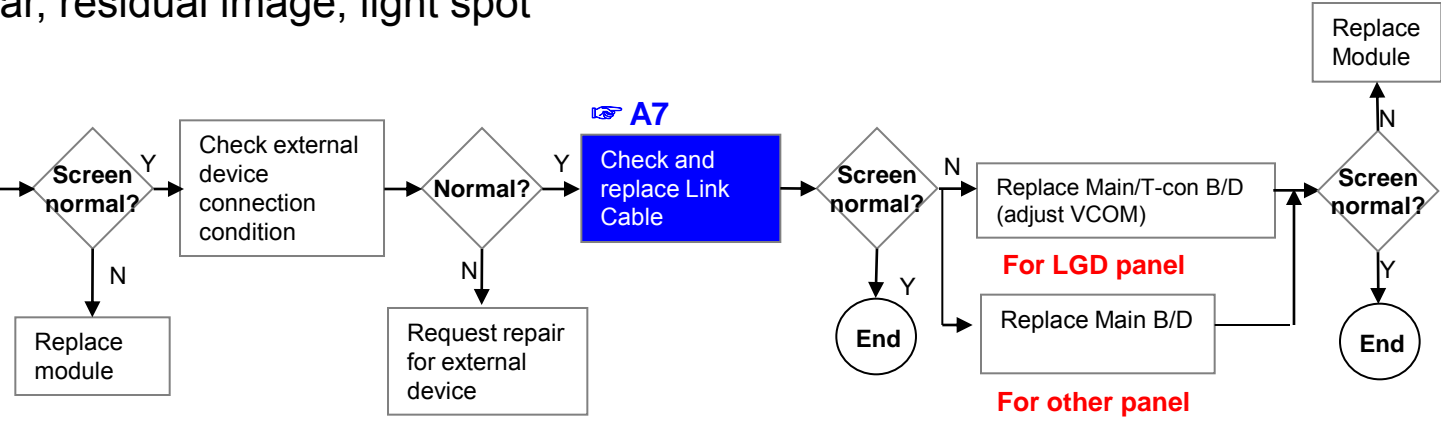

### External device screen error-Color error

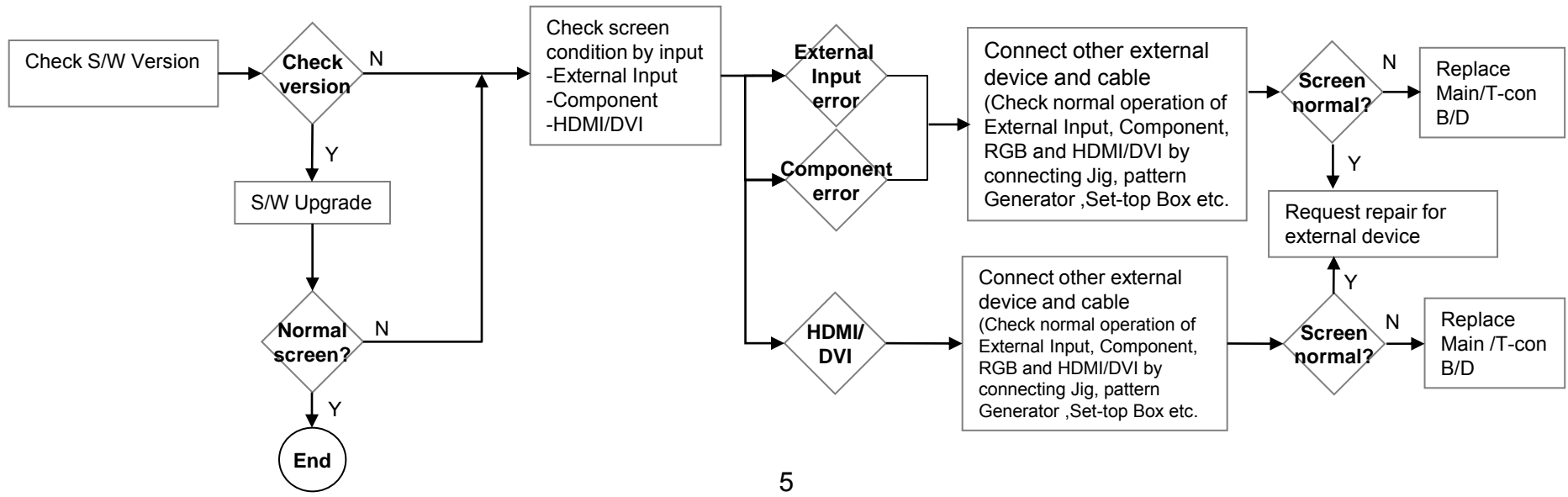

LCD TV	Error symptom	<b>B. Power error</b>	Established date	2013.01.31	
		No power	Revised date		6/16

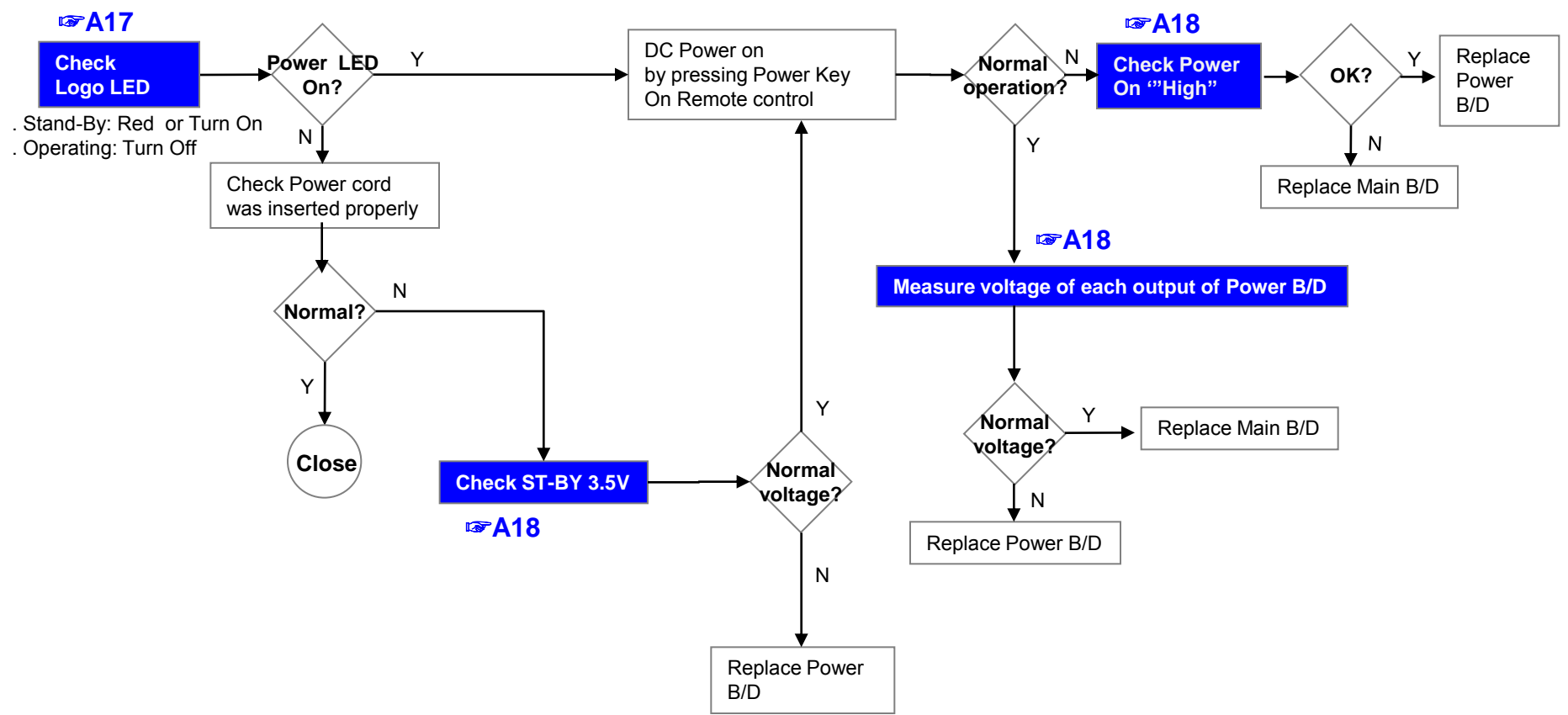

LCD TV	Error symptom	<b>B. Power error</b>	Established date	2013.01.31	
		Off when on, off while viewing, power auto on/off	Revised date		7/16

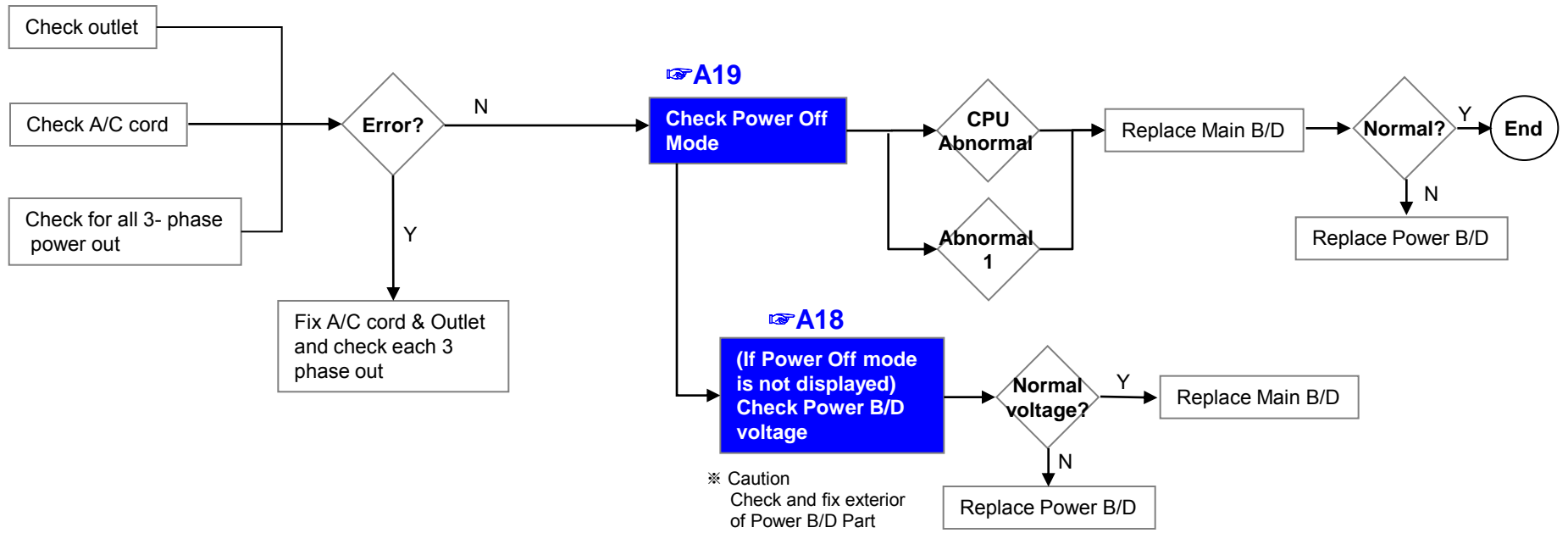

\* Please refer to the all cases which can be displayed on power off mode.

Status	Power off List	Explanation
Normal	"POWEROFF_REMOTEKEY"	Power off by REMOTE CONTROL
	"POWEROFF_OFFTIMER"	Power off by OFF TIMER
	"POWEROFF_SLEEPTIMER"	Power off by SLEEP TIMER
	"POWEROFF_INSTOP"	Power off by INSTOP KEY
	"POWEROFF_AUTOOFF"	Power off by AUTO OFF
	"POWEROFF_ONTIMER"	Power off by ON TIMER
	"POWEROFF_RS232C"	Power off by RS232C
	"POWEROFF_RESREC"	Power off by Reserved Record
	"POWEROFF_RECEND"	Power off by End of Recording
	"POWEROFF_SWDOWN"	Power off by S/W Download
	"POWEROFF_UNKNOWN"	Power off by unknown status except listed case
Abnormal	"POWEROFF_ABNORMAL1"	Power off by abnormal status except CPU trouble
	"POWEROFF_CPUABNORMAL"	Power off by CPU Abnormal

LCD TV

Error symptom

C. Audio error

Established date

2013.01.31

No audio/ Normal video

Revised date

8/16

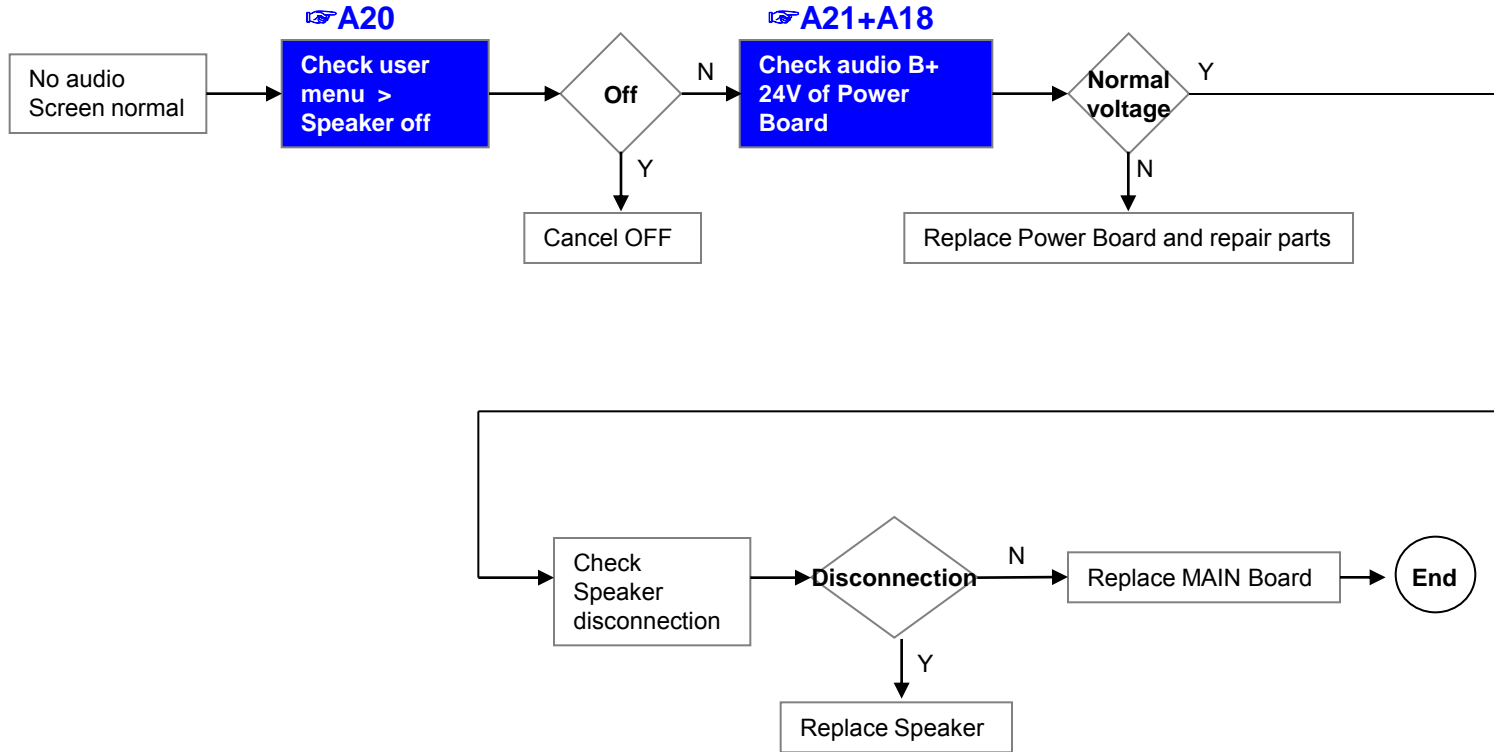

LCD TV	Error symptom	<b>C. Audio error</b>	Established date	2013.01.31	
		Wrecked audio/ discontinuation/noise	Revised date		9/16

→ abnormal audio/discontinuation/noise is same after “Check input signal” compared to No audio

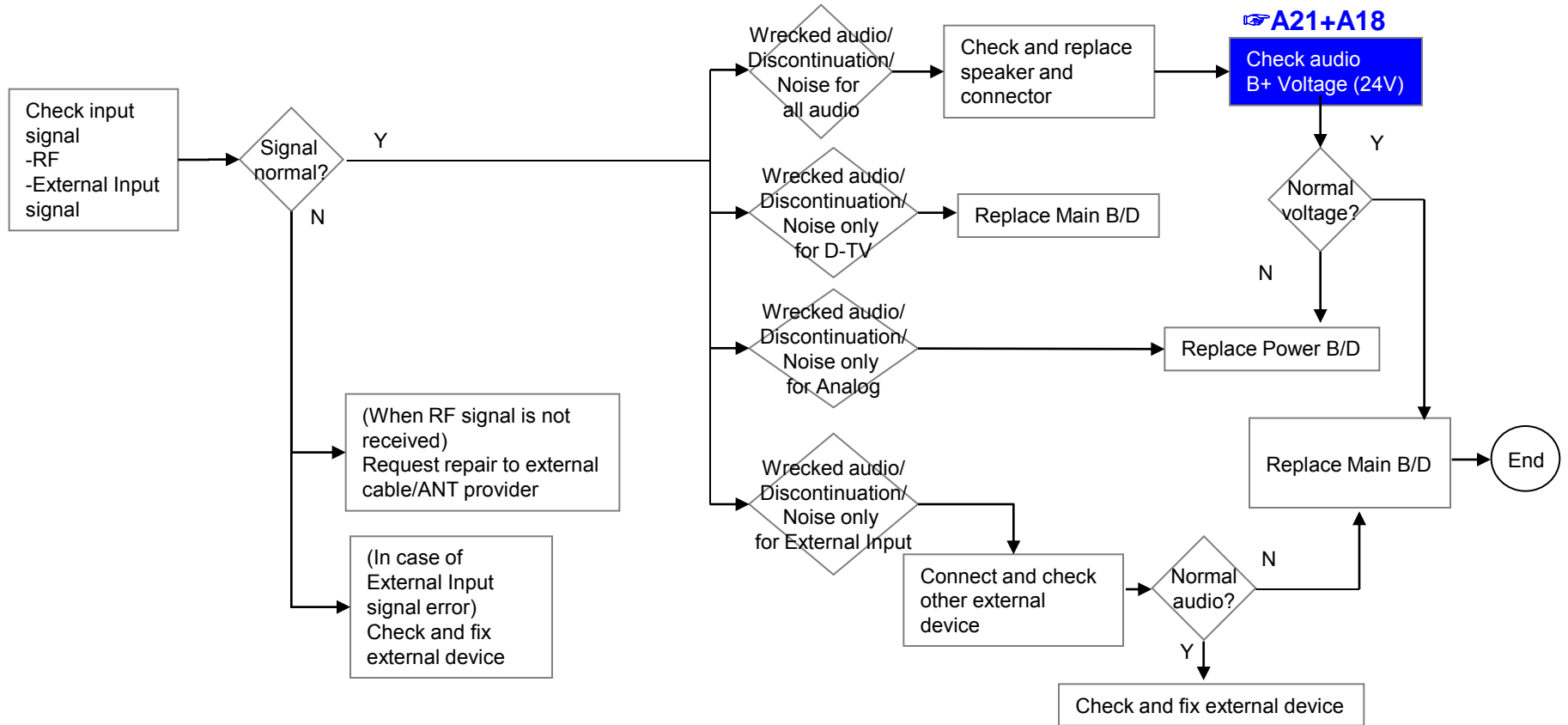

LCD TV	Error symptom	D. Function error	Established date	2013.01.31	
		Remote control & Local switch checking	Revised date		10/16

### 1. Remote control(R/C) operating error

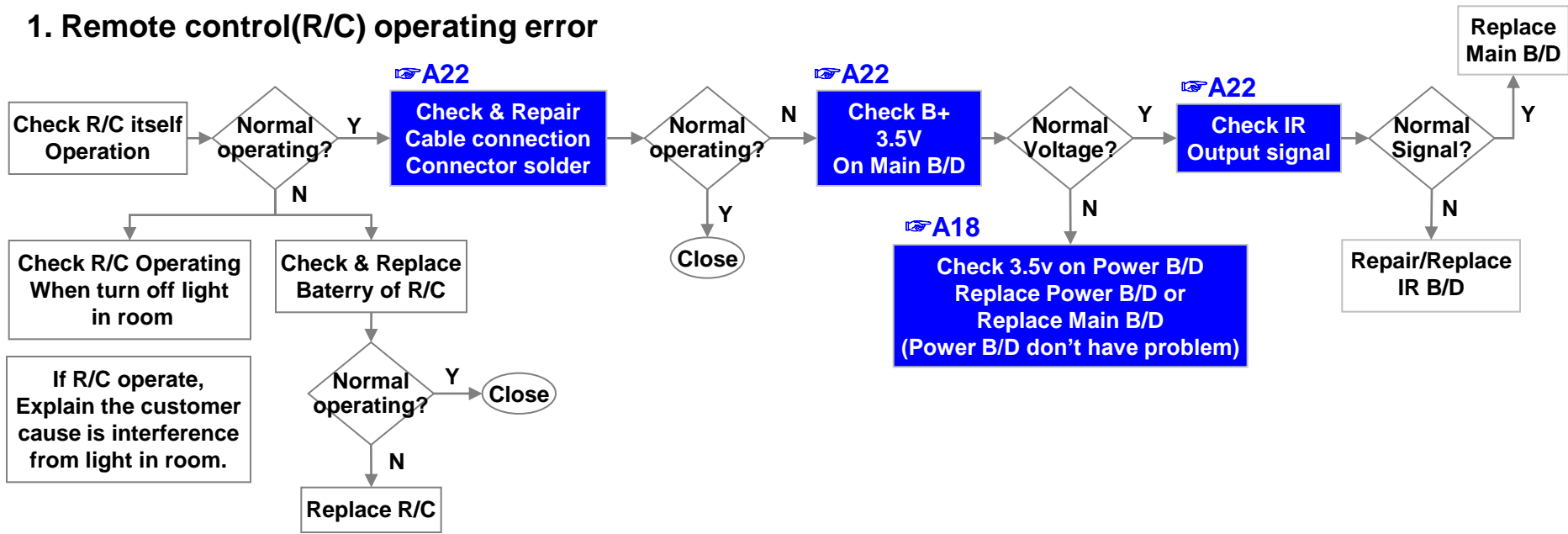

LCD TV	Error symptom	D. Function error	Established date	2013.01.31	
		MR operating checking	Revised date		11/16

## 2. MR(Magic Remocon) operating error

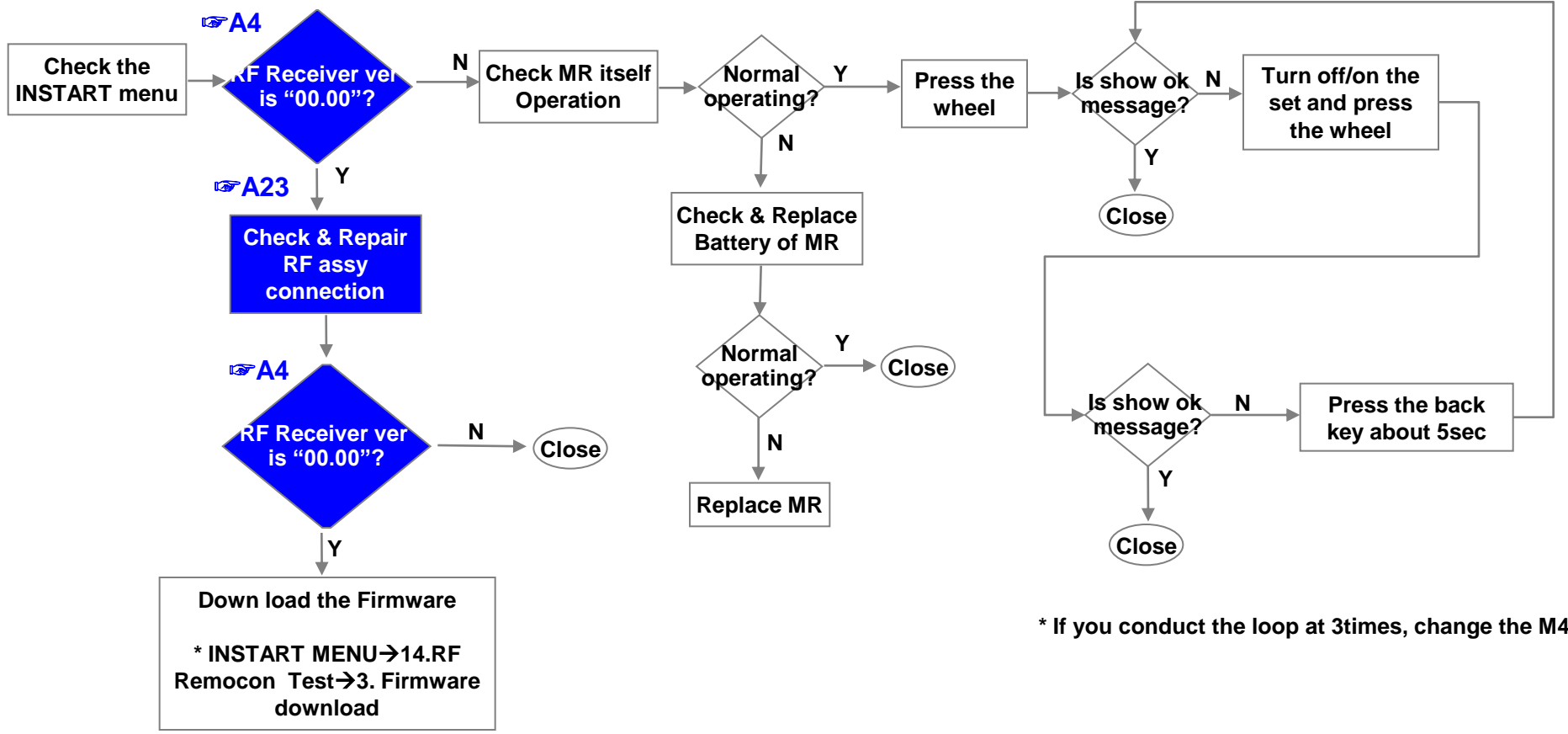



LCD TV	Error symptom	D. Function error	Established date	2013.01.31	
		Wifi operating checking	Revised date		12/16

### 3.Wifi operating error

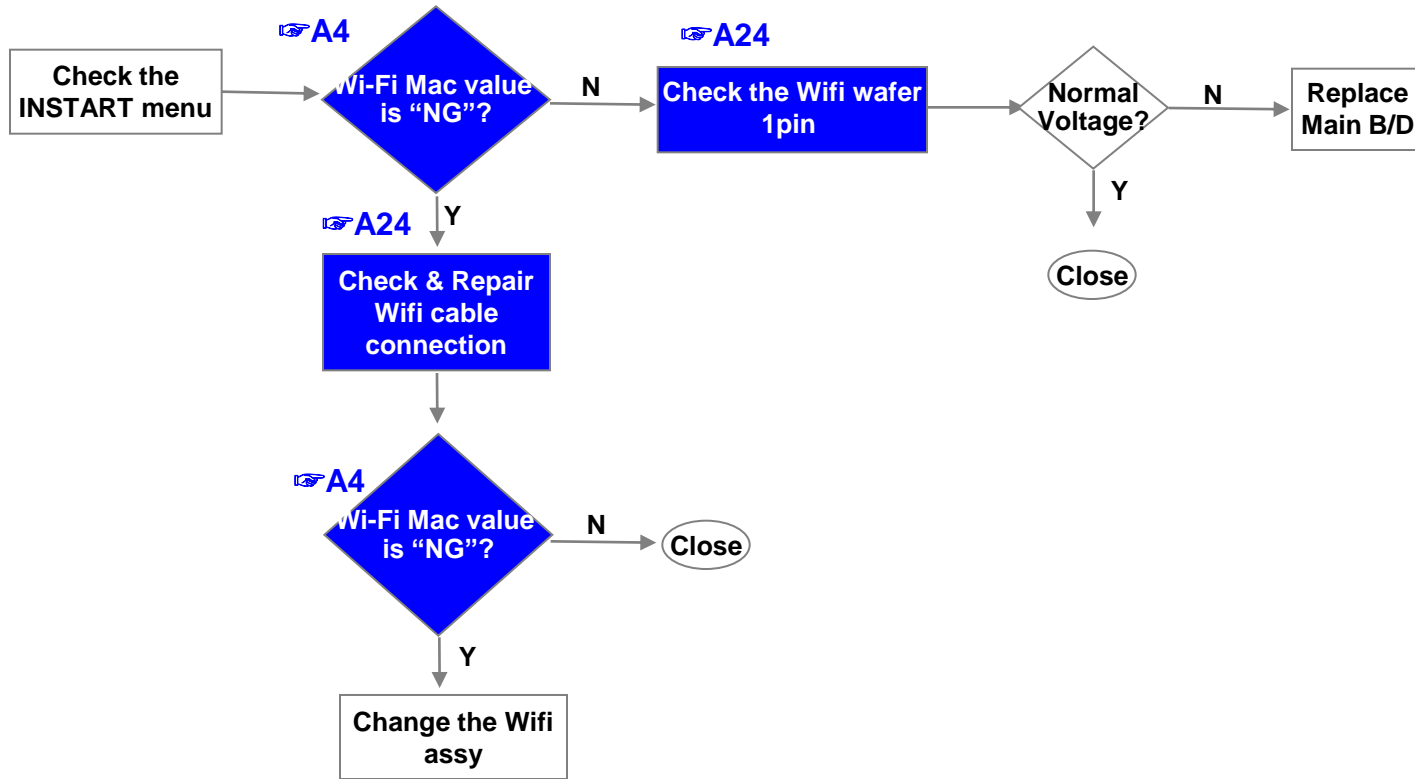

LCD TV	Error symptom	D. Function error	Established date	2013.01.31	
		External device recognition error	Revised date		14/16

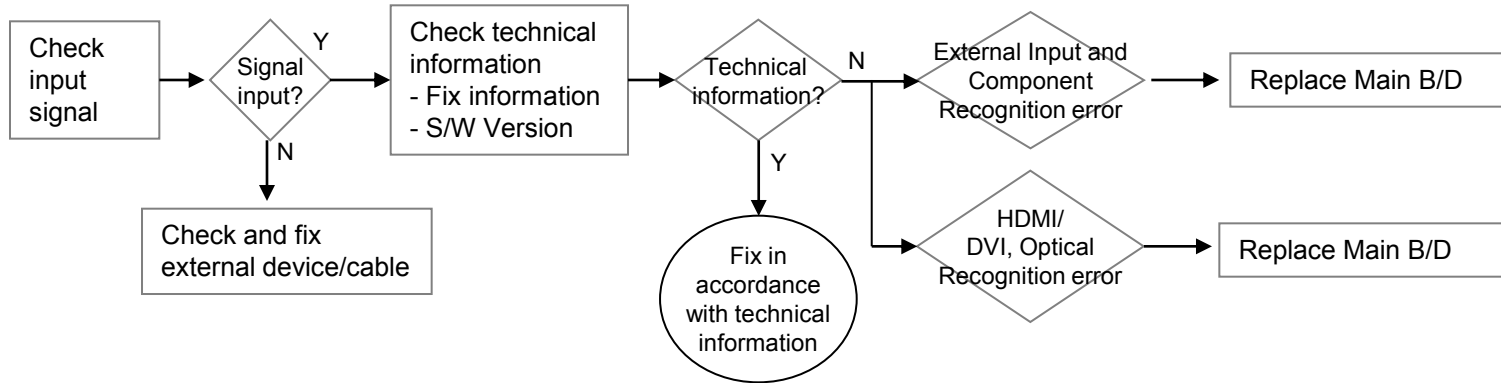

LCD TV	Error symptom	<b>E. Noise</b>	Established date	2013.01.31	
		Circuit noise, mechanical noise	Revised date		15/16

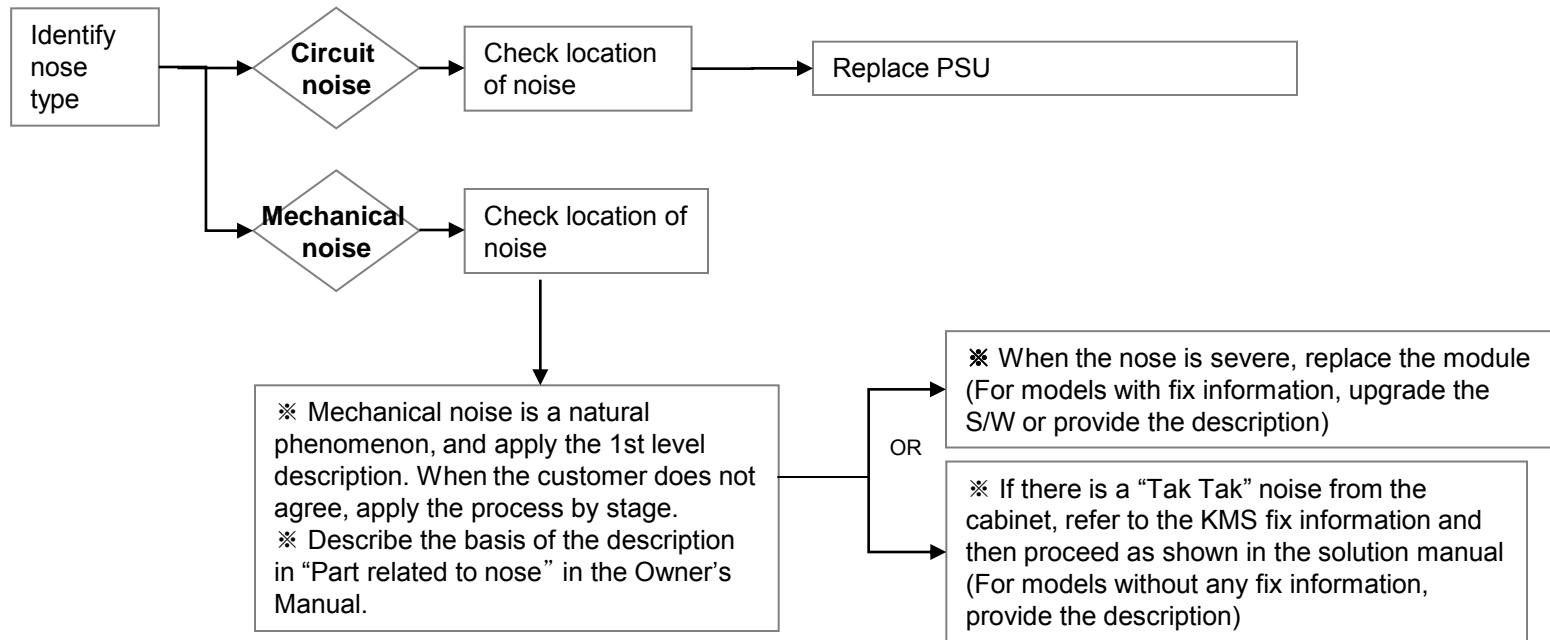

<b>LCD TV</b>	<b>Error symptom</b>	<b>F. Exterior defect</b>	<b>Established date</b>	<b>2013.01.31</b>	
		Exterior defect	<b>Revised date</b>		<b>16/16</b>

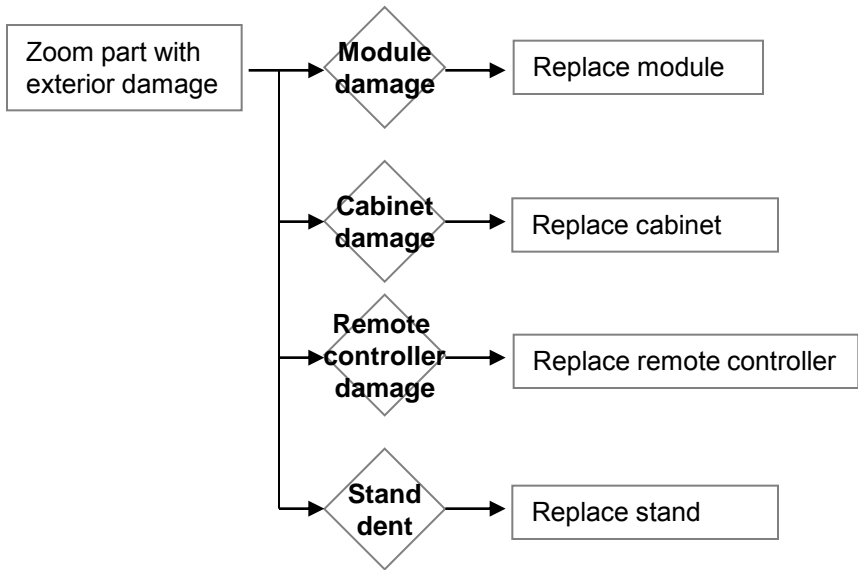

# Contents of LCD TV Standard Repair Process Detail Technical Manual

No.	Error symptom	Content	Page	Remarks
1	A. Video error_ No video/Normal audio	Check LCD back light with naked eye	A1	
2		Check White Balance value	A2	
4	A. Video error_ video error /Video lag/stop	TUNER input signal strength checking method	A3	
5		LCD-TV Version checking method	A4	
6		Tuner Checking Part	A5	
7	A. Video error _Vertical/Horizontal bar, residual image, light spot	LCD TV connection diagram	A6	
8	A. Video error_ Color error	Check Link Cable (EPI) reconnection condition	A7	
9		Adjustment Test pattern – ADJ Key	A8	
10	<b>&lt;Appendix&gt;</b> Defected Type caused by T-Con/ Inverter/ Module	Exchange Main Board (1)	A-1/5	
11		Exchange Main Board (2)	A-2/5	
12		Exchange Power Board (PSU)	A-3/5	
13		Exchange Module (1)	A-4/5	
14		Exchange Module (2)	A-5/5	

Continue to the next page

# Contents of LCD TV Standard Repair Process Detail Technical Manual

Continued from previous page

No.	Error symptom	Content	Page	Remarks
16	B. Power error_ No power	Check front display LED	A17	
17		Check power input Voltage & ST-BY 3.5V	A18	
18	B. Power error_Off when on, off while viewing	POWER OFF MODE checking method	A19	
19	C. Audio error_ No audio/Normal video	Checking method in menu when there is no audio	A20	
20		Voltage and speaker checking method when there is no audio	A21	
21	D. Function error	Remote controller operation checking method	A22	
22		Motion Remote operation checking method	A23	
23		Wifi operation checking method	A24	
24		Camera operation checking method	A25	Not Used
25	E. Etc	Tool option changing method	A26	

# Standard Repair Process Detail Technical Manual

LCD TV	Error symptom	A. Video error_No video/Normal audio	Established date	2013.01.31	
	Content	Check LCD back light with naked eye	Revised date		A1

<XXUB83/820X-XX>

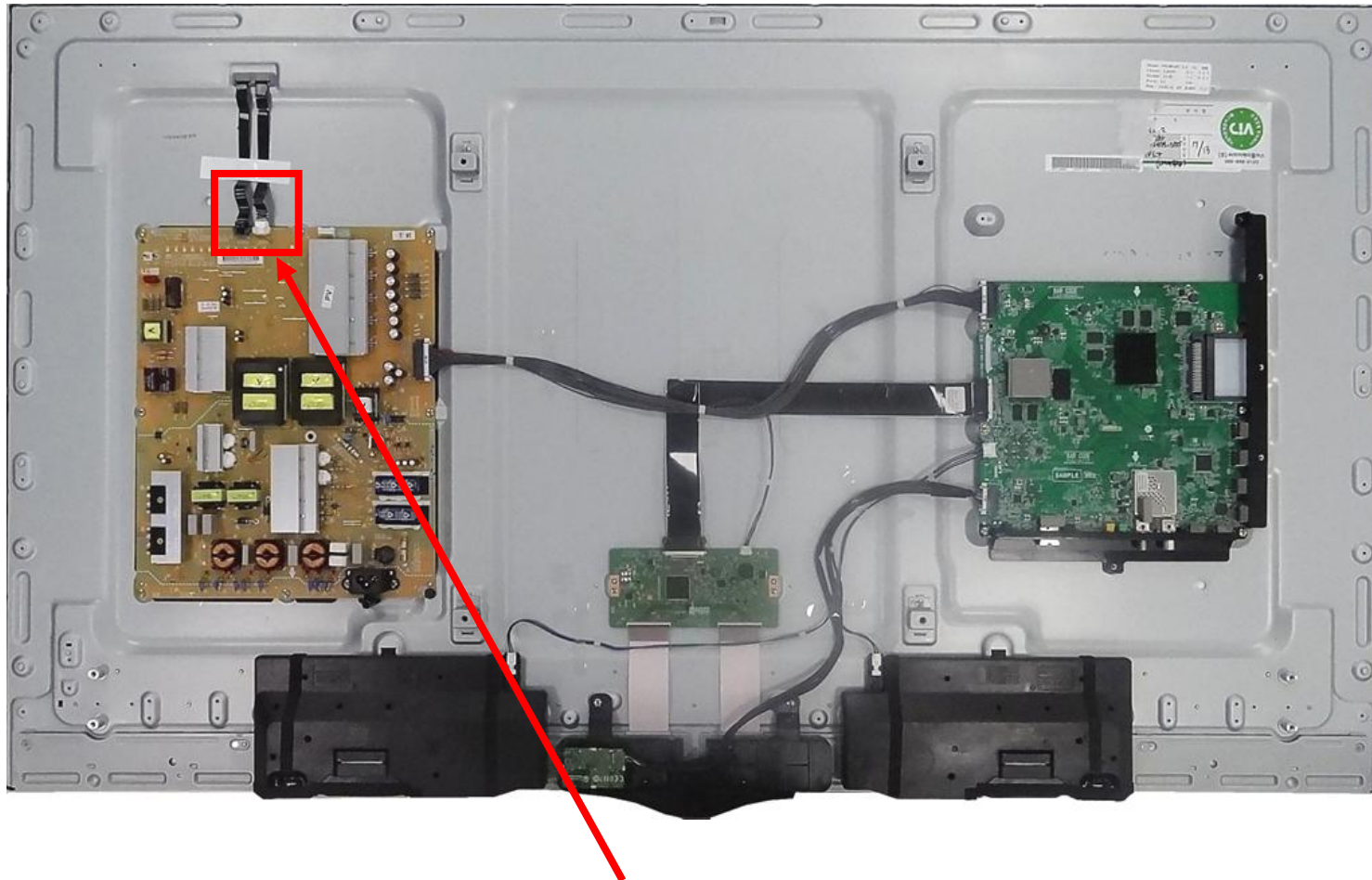

After turning on the power and disassembling the case, check with the naked eye, whether you can see light from locations.

# Standard Repair Process Detail Technical Manual

LCD TV	Error symptom	A. Video error_No video/Normal audio	Established date	2014.02.14	
	Content	Check White Balance value	Revised date		A2

<ALL MODELS>

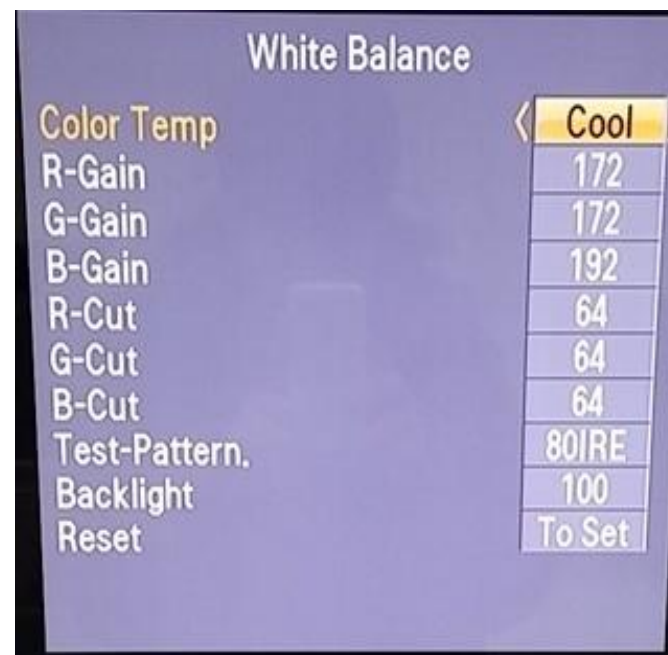
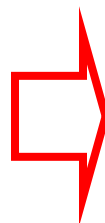
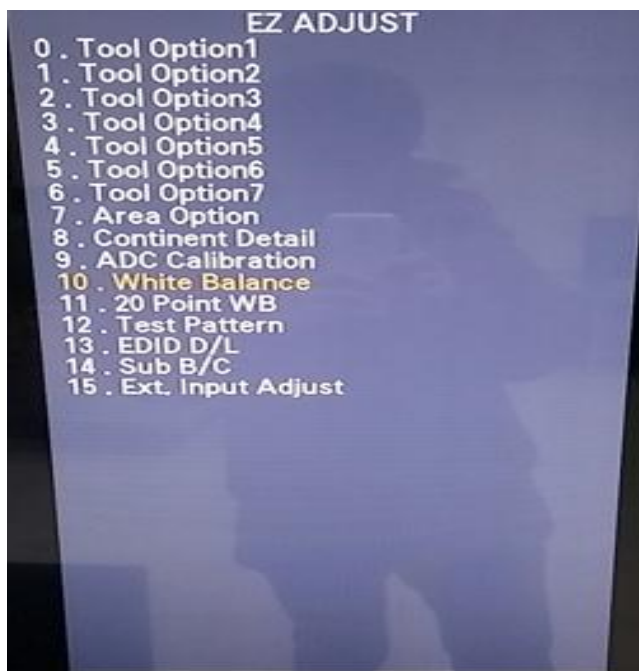

## Entry method

1. Press the ADJ button on the remote controller for adjustment.
2. Enter into White Balance of item 10.
3. After recording the R, G, B (GAIN, Cut) value of Color Temp (Cool/Medium/Warm), re-enter the value after replacing the MAIN BOARD.



# Standard Repair Process Detail Technical Manual

LCD TV	Error symptom	A. Video error_Video error, video lag/stop	Established date	2014.02.14	
	Content	TUNER input signal strength checking method	Revised date		A3

<ALL MODELS>

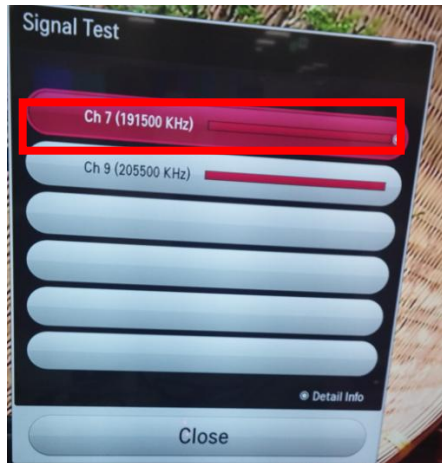
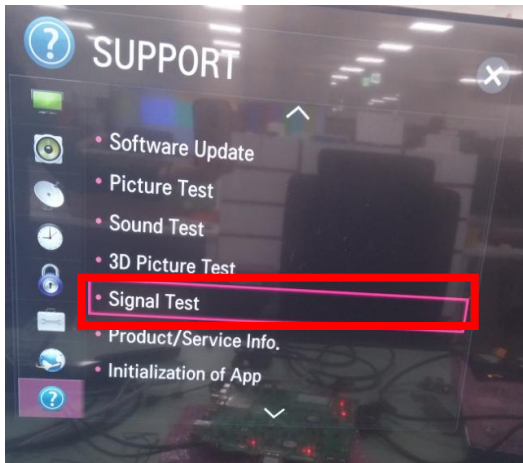

MENU → support → signal test  
→ select channel

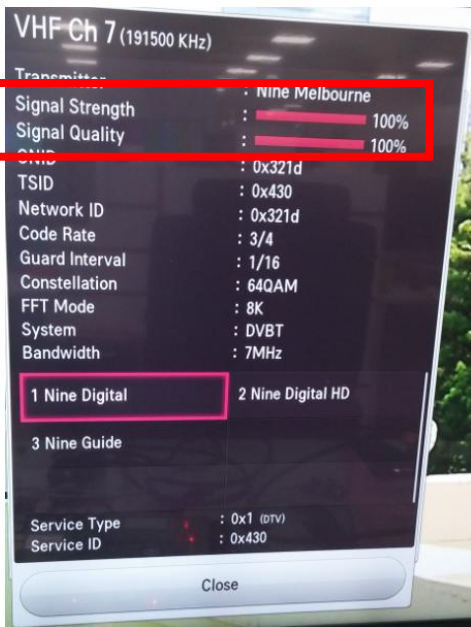

When the signal is strong, use the attenuator (-10dB, -15dB, -20dB etc.)



# Standard Repair Process Detail Technical Manual

LCD TV	Error symptom	A. Video error_Video error, video lag/stop	Established date	2014.02.14	
	Content	LCD-TV Version checking method	Revised date		A4

<ALL MODELS>

## 1. Checking method for remote controller for adjustment

Version

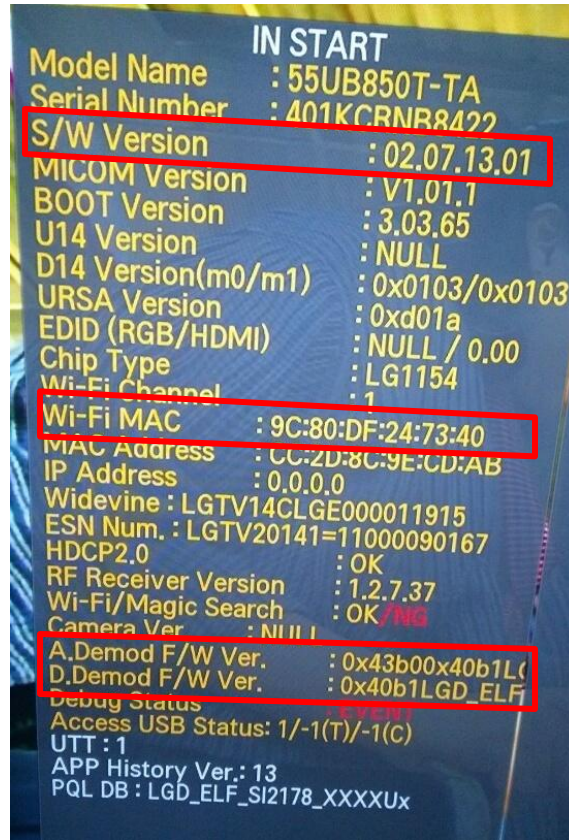

Press the IN-START with the remote controller for adjustment

# Standard Repair Process Detail Technical Manual

LCD TV	Error symptom	A. Video error_Video error, video lag/stop	Established date	2014.02.14	
	Content	TUNER checking part	Revised date		A5

<ALL MODELS>

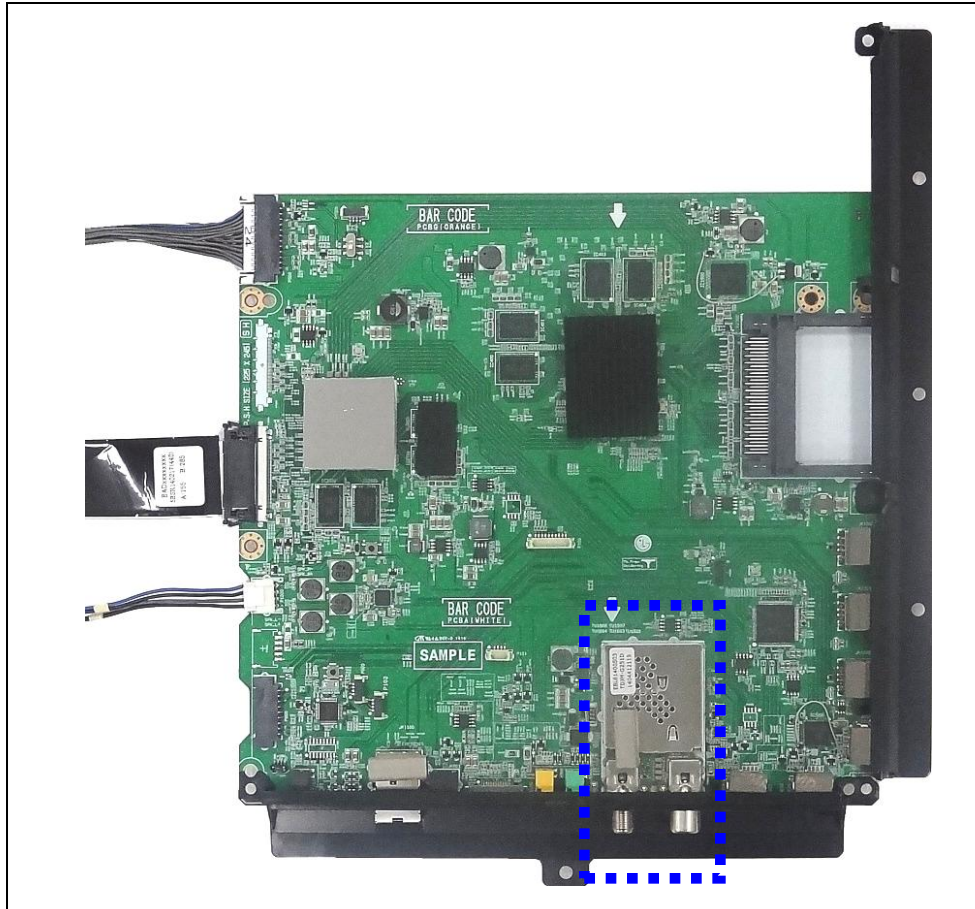

Checking method:

1. Check the signal strength or check whether the screen is normal when the external device is connected.
2. After measuring each voltage from power supply, finally replace the MAIN BOARD.

# Standard Repair Process Detail Technical Manual

LCD TV	Error symptom	A. Video error _Vertical/Horizontal bar, residual image, light spot	Established date	2014.02.14	
	Content	LCD TV connection diagram (1)	Revised date		A6

<ALL MODELS>

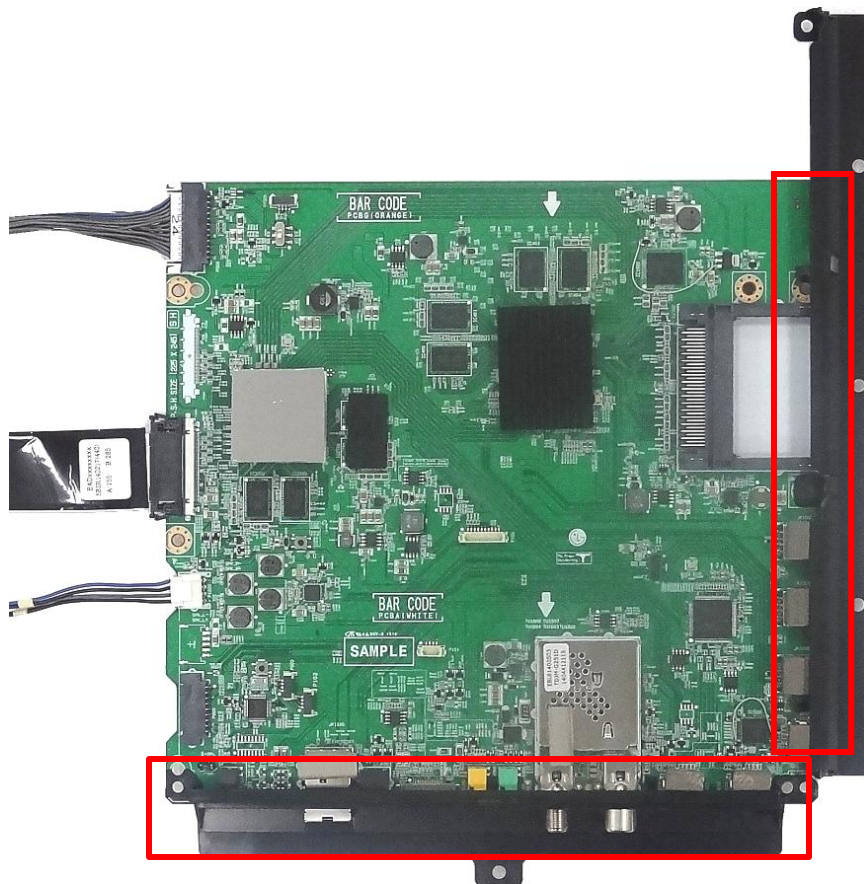

As the part connecting to the external input, check the screen condition by signal

# Standard Repair Process Detail Technical Manual

LCD TV	Error symptom	A. Video error_Color error	Established date	2014.02.14	
	Content	Check Link Cable (LVDS) reconnection condition	Revised date		A7

<ALL MODELS>

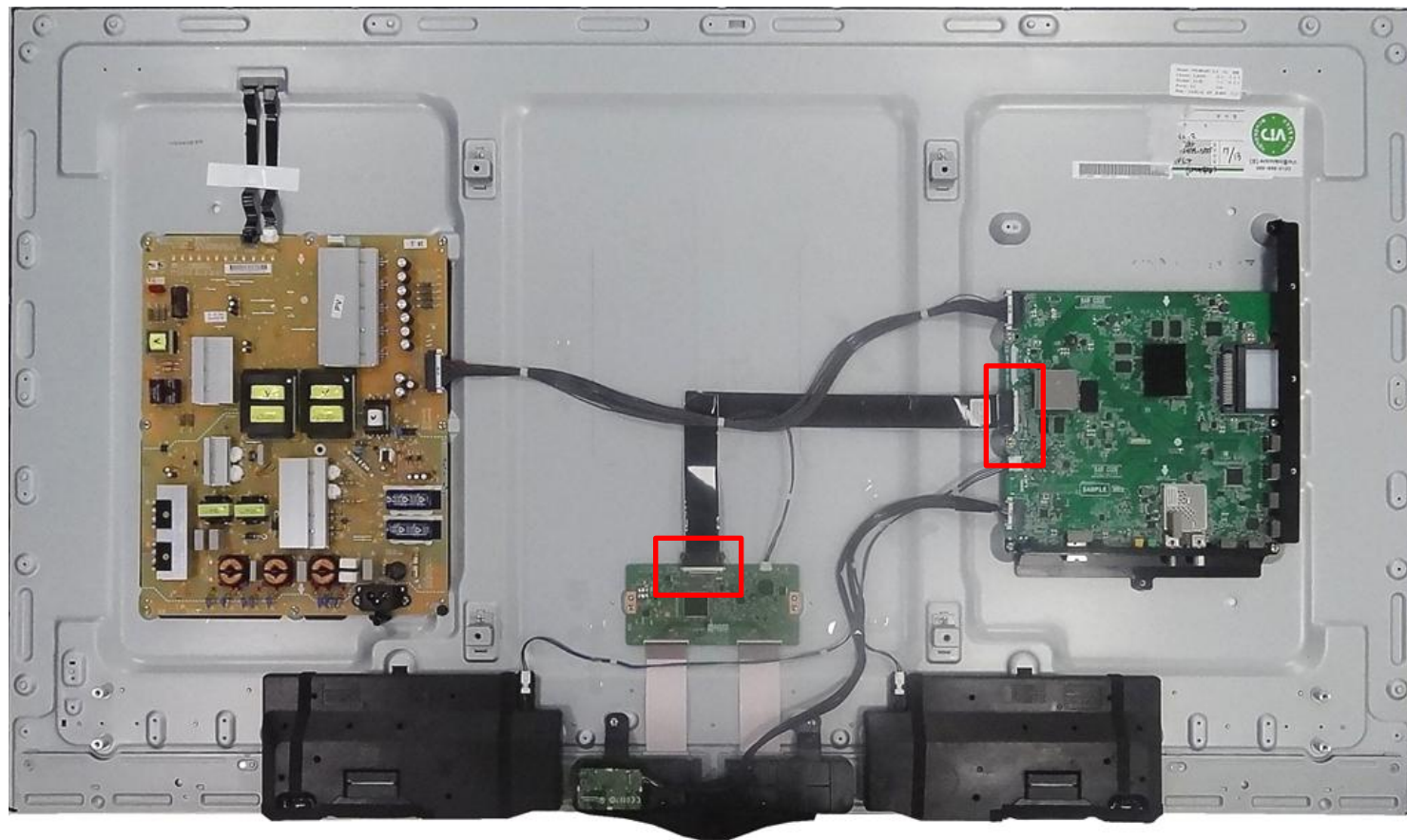

Check the contact condition of the Link Cable, especially dust or mis insertion.

# Standard Repair Process Detail Technical Manual

LCD TV	Error symptom	A. Video error_Color error	Established date	2014.02.14	
	Content	Adjustment Test pattern - ADJ Key	Revised date		A8

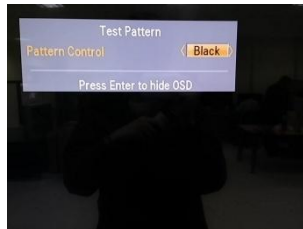
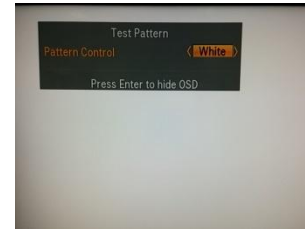
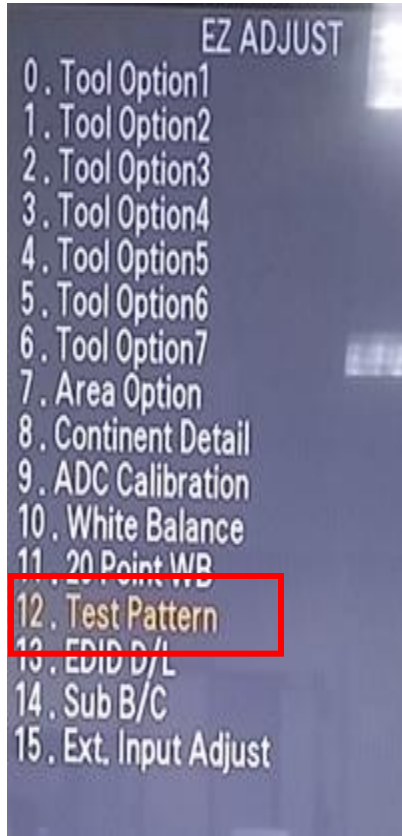

You can view 6 types of patterns using the ADJ Key

Checking item : 1. Defective pixel 2. Residual image 3. MODULE error (ADD-BAR,SCAN BAR..) 4.Video error (Classification of MODULE or Main-B/D!)

# Appendix : Exchange Main Board (1)



Solder defect, CNT Broken



Solder defect, CNT Broken

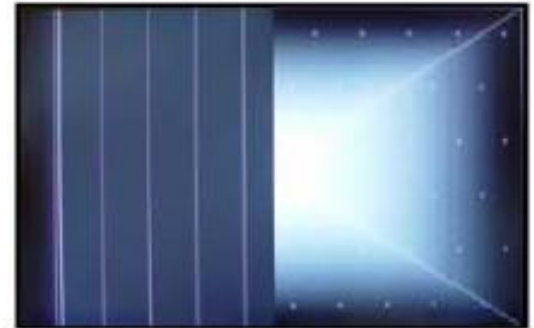

Solder defect, CNT Broken



Solder defect, CNT Broken

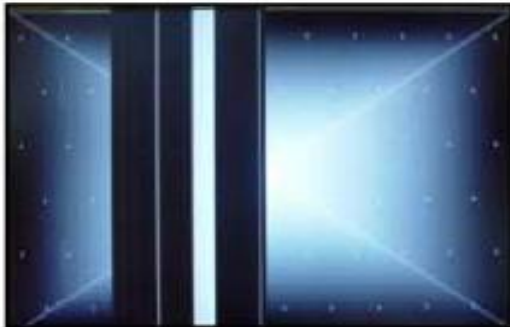

Solder defect, CNT Broken



Abnormal Power Section

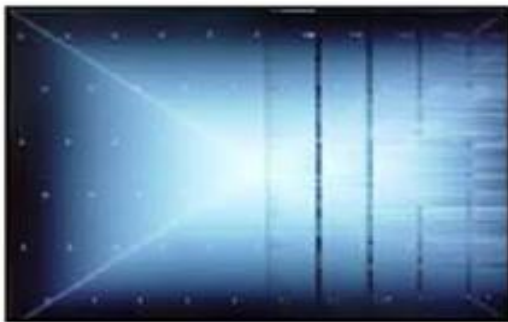

Solder defect, Short/Crack



Abnormal Power Section



Solder defect, Short/Crack

# Appendix : Exchange Main Board (2)

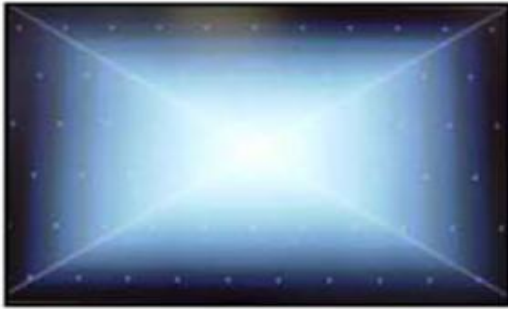

Abnormal Power Section



Abnormal Power Section



Solder defect, Short/Crack



Solder defect, Short/Crack



Fuse Open, Abnormal power section



Abnormal Display



GRADATION



Noise

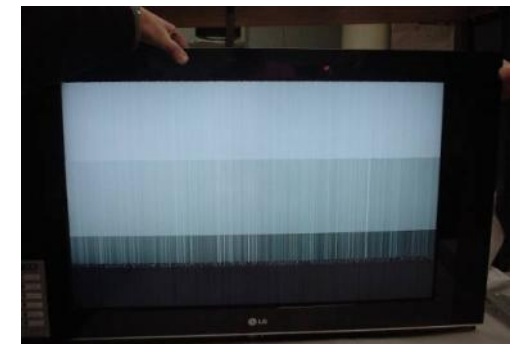

GRADATION



# Appendix : Exchange Power Board (PSU)



No Light



Dim Light



Dim Light

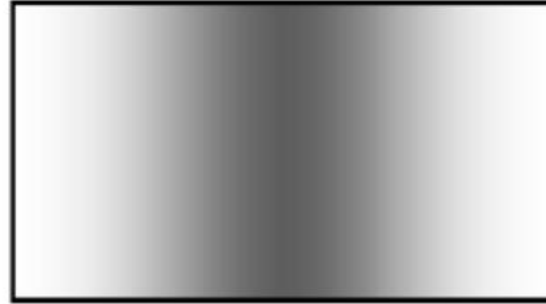

Dim Light



No picture/Sound Ok

## Appendix : Exchange the Module (1)



Panel Mura, Light leakage



Panel Mura, Light leakage



Press damage

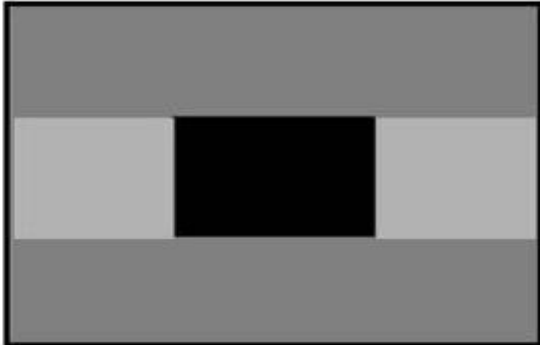

Crosstalk



Press damage



Crosstalk



Press damage

---

### Un-repairable Cases

In this case please exchange the module.

## Appendix : Exchange the Module (2)

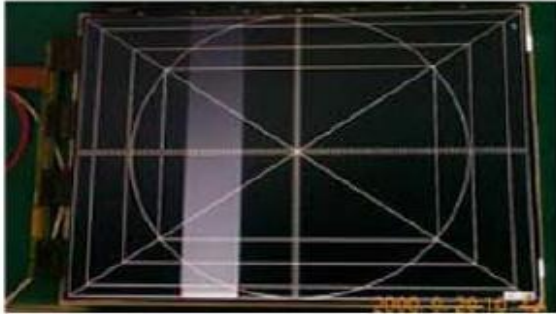

Vertical Block  
Source TAB IC Defect



Vertical Line  
Source TAB IC Defect



Vertical Block  
Source TAB IC Defect



Horizontal Block  
Gate TAB IC Defect



Horizontal Block  
Gate TAB IC Defect

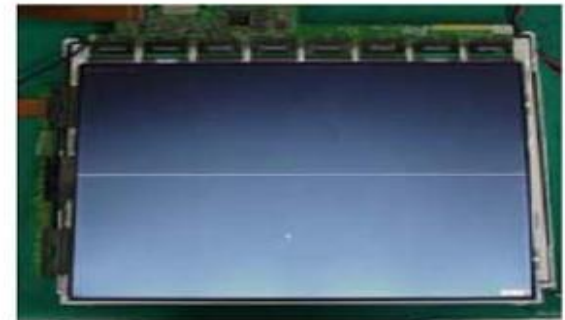

Horizontal line  
Gate TAB IC Defect



Horizontal Block  
Gate TAB IC Defect

### Un-repairable Cases

In this case please exchange the module.

# Standard Repair Process Detail Technical Manual

LCD TV	Error symptom	B. Power error _No power	Established date	2014.02.07	
	Content	Check front Power Indicator	Revised date		A17

<XXUB83/820X-XX>

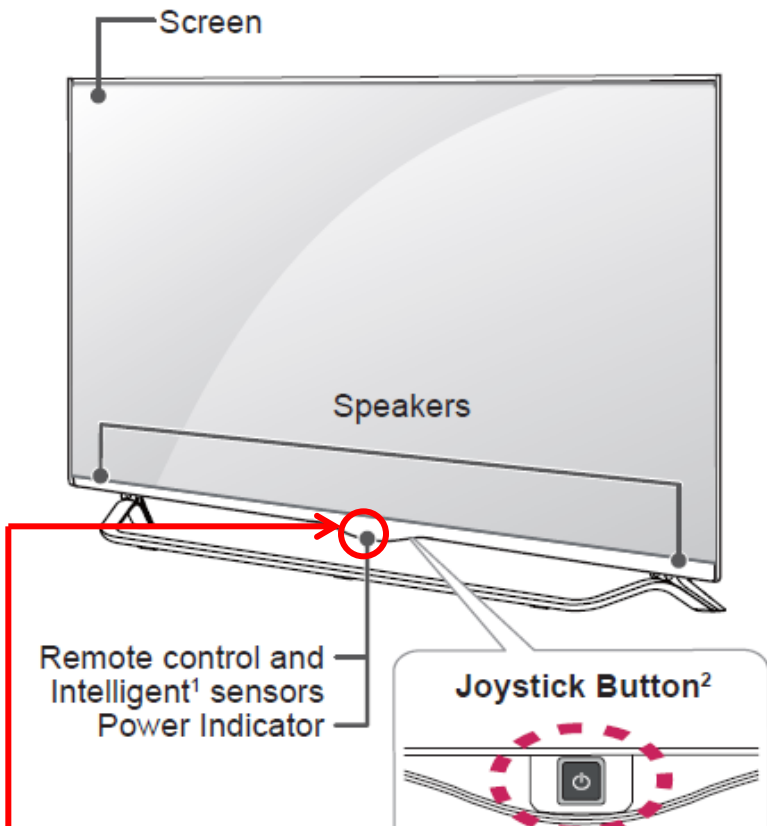

### NOTE

- You can set the LG Logo Light or power indicator light to on or off by selecting GENERAL in the main menus.

## Using the joystick button

You can operate the TV by pressing the button or moving the joystick left, right, up, or down.

### Basic Functions

	Power On	When the TV is turned off, place your finger on the joystick button and press it once and release it.
	Power Off	When the TV is turned on, place your finger on the joystick button and press it once for a few seconds and release it.
	Volume Control	If you place your finger over the joystick button and move it left or right, you can adjust the volume level you want.
	Programmes Control	If you place your finger over the joystick button and move it up or down, you can scrolls through the saved programmes you want.

### NOTE

- When your finger over the joystick button and push it to the up, down, left or right, be careful not to press the joystick button. If you press the joystick button first, you can not adjust the volume level and saved programmes.

### Adjusting the Menu

When the TV is turned on, press the joystick button one time.

You can adjust the Menu items (⏻, ✕, 📺) moving the joystick button up, down, left or right.

	TV OFF	Turns the power off.
	CLOSE	Clears on-screen displays and return to TV viewing.
	INPUT	Changes the input source.

ST-BY condition: On or Off  
Power ON condition: Turn Off

# Standard Repair Process Detail Technical Manual

LCD TV	Error symptom	B. Power error _No power	Established date	2014.02.05	
	Content	Check power input voltage and ST-BY 3.5V	Revised date		A18

Check the DC 24V, 12V, 3.5V.

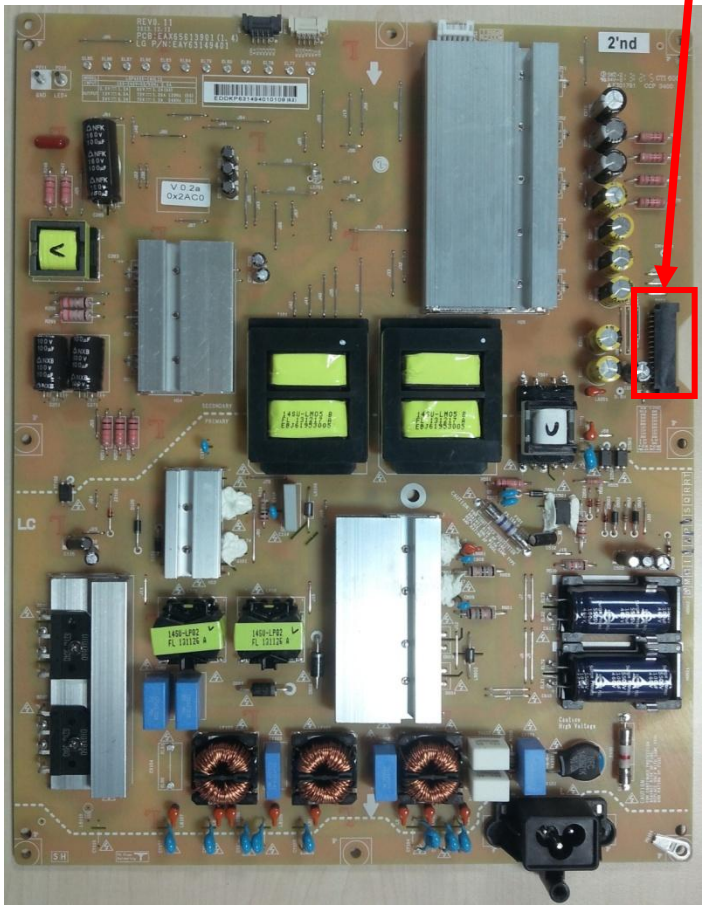

P\_main  
 Maker : Yeonho  
 28Pin SMAW200-H28S5K  
 '14년 적용 28Pin map (LPB)

1	PWR ON	2	DVR_ON
3	P_DIM #1	4	PDIM #2
5	3.5V	6	GND
7	3.5V	8	3.5V
9	GND	10	GND
11	12V	12	12V
13	12V	14	12V
15	12V	16	GND
17	GND	18	24V
19	24V	20	24V
21	24V	22	24V
23	GND	24	GND
25	SCLK	26	GND
27	SIN	28	VSYN

# Standard Repair Process Detail Technical Manual

LCD TV	Error symptom	B. Power error _Off when on, off whiling viewing	Established date	2014.02.05	
	Content	POWER OFF MODE checking method	Revised date		A19

<ALL MODELS>

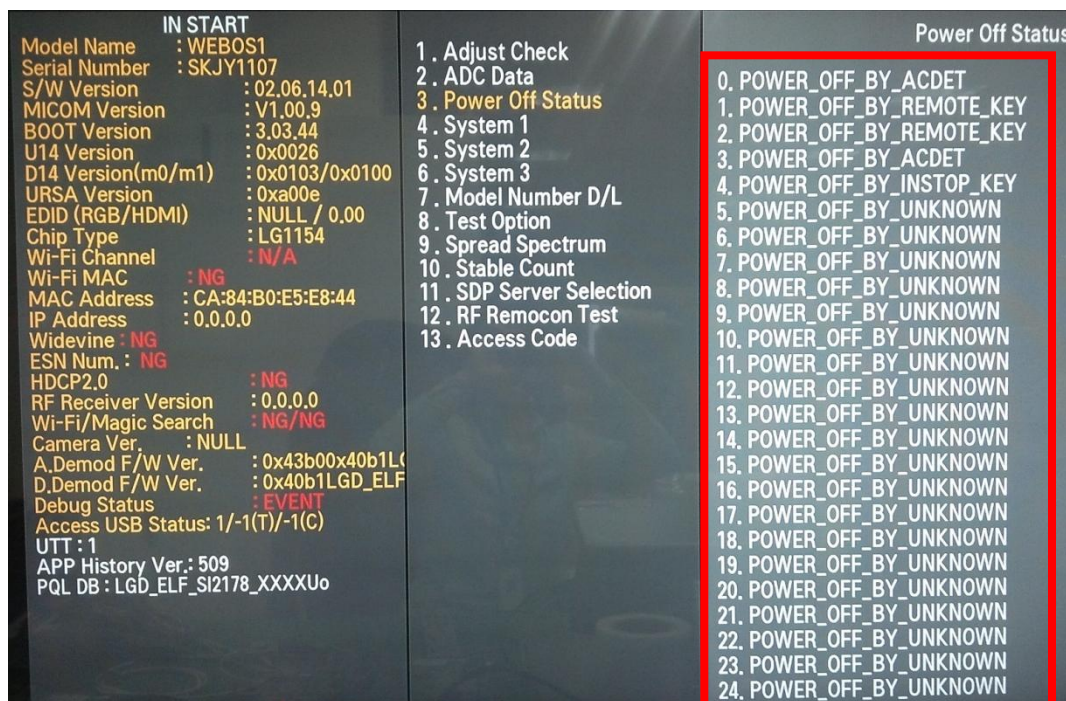

## Entry method

1. Press the IN-START button of the remote controller for adjustment
2. Check the entry into adjustment item 3

# Standard Repair Process Detail Technical Manual

LCD TV	Error symptom	C. Audio error_No audio/Normal video	Established date	2014.02.05	
	Content	Checking method in menu when there is no audio	Revised date		A20

<XXUB83/820X-XX>

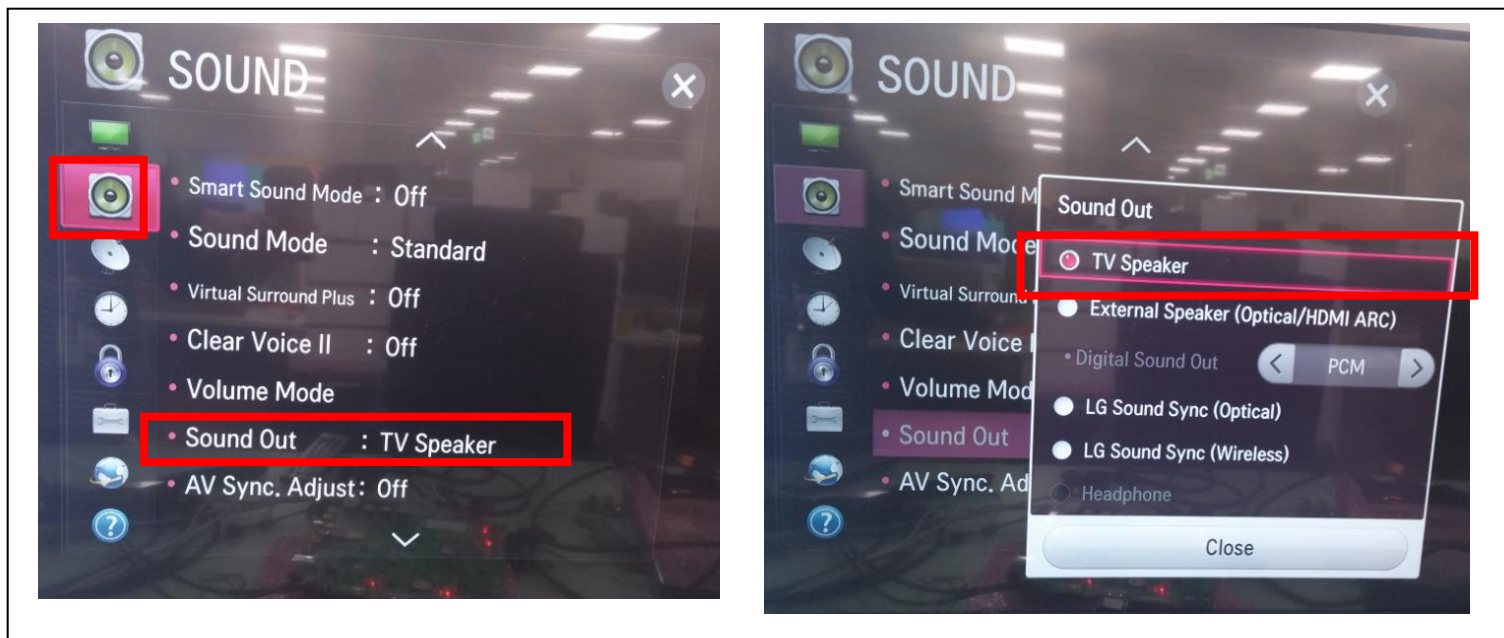

## Checking method

1. Press the Setting button on the remote controller
2. Select the Sound function of the Menu
3. Select the Sound Out
4. Select TV Speaker

# Standard Repair Process Detail Technical Manual

LCD TV	Error symptom	C. Audio error_No audio/Normal video	Established date	2014.02.05	
	Content	Voltage and speaker checking method when there is no audio	Revised date		A21

<XXUB83/820X-XX>

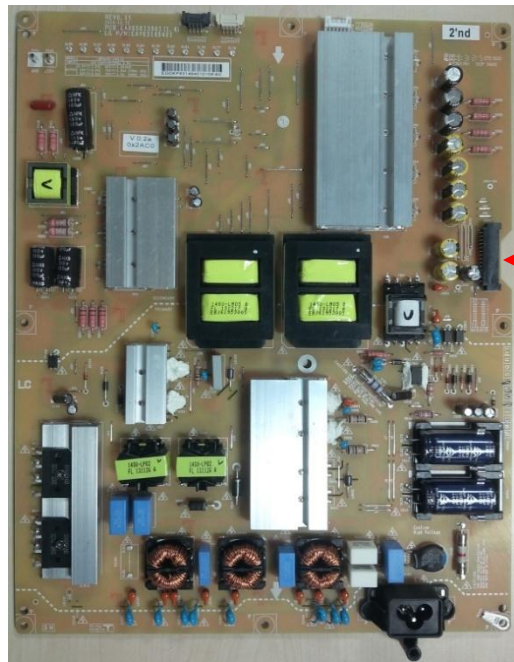

1	PWR ON	2	DVR_ON
3	P_DIM #1	4	PDIM #2
5	3.5V	6	GND
7	3.5V	8	3.5V
9	GND	10	GND
11	12V	12	12V
13	12V	14	12V
15	12V	16	GND
17	GND	18	24V
19	24V	20	24V
21	24V	22	24V
23	GND	24	GND
25	SCLK	26	GND
27	SIN	28	VSYNC

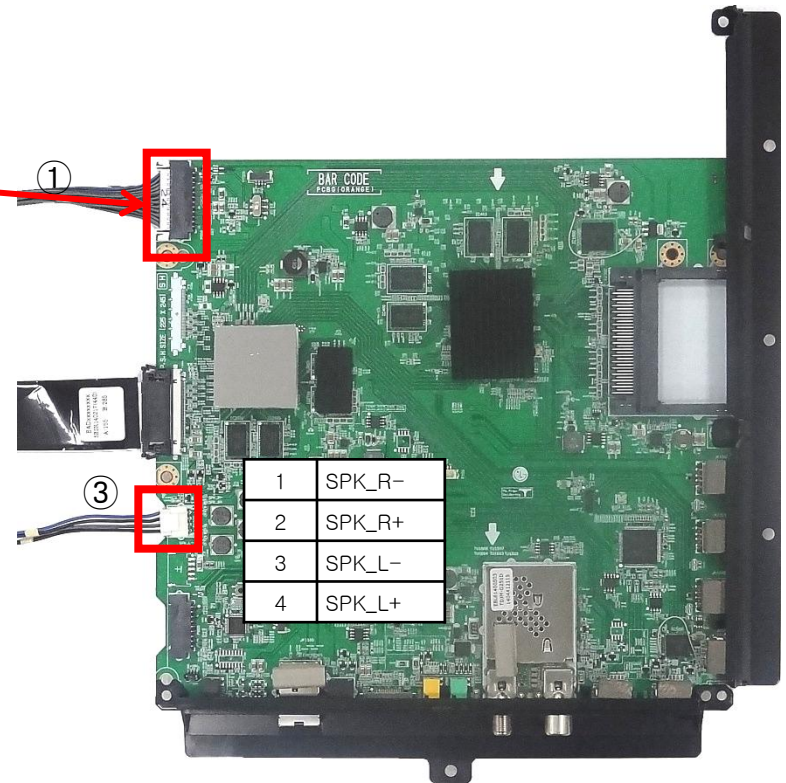

## Checking order when there is no audio

1. Check the contact condition of or 24V connector of Main Board
2. Measure the 24V input voltage supplied from Power Board  
(If there is no input voltage, remove and check the connector)
3. Connect the tester RX1 to the speaker terminal and if you hear the Chik Chik sound when you touch the GND and output terminal, the speaker is normal.



# Standard Repair Process Detail Technical Manual

LCD TV	Error symptom	D. Function error	Established date	2014.02.07	
	Content	Remote controller operation checking method	Revised date		A22

<XXUB83/820X-XX>

Front



Back



① Wifi/ BT Combo

## Checking order to check remote controller

### Checking order

1. Check IR cable condition between IR & Main board. ( Check picture number ① and ② )
2. Check the standby 3.5V on the terminal 16 pin ( ③ )
3. AS checking the Pre-Amp (IR LED light) , the power is in ON condition, an Analog Tester needle should move slowly, otherwise, it's defective.

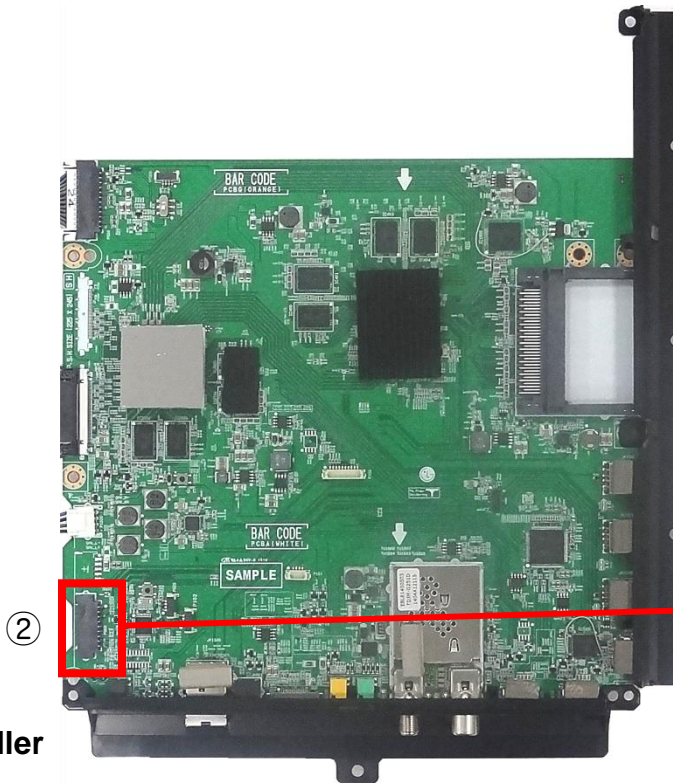

1	GND
2	+3.5V WOL
3	BT_RESET
4	USB_DM
5	NC
6	USB_DP
7	WOL
8	GND
9	SDA
10	GND
11	SCL
12	KEY1
13	GND
14	KEY2
15	IR
16	+3.5V_ST
17	LED_R
18	GND

# Standard Repair Process Detail Technical Manual

LCD TV	Error symptom	D. Function error	Established date	2014.02.07	
	Content	Motion Remote / Wifi operation checking method	Revised date		A23

<XXUB83/820X-XX>

Front



Back



① Wifi/ BT Combo

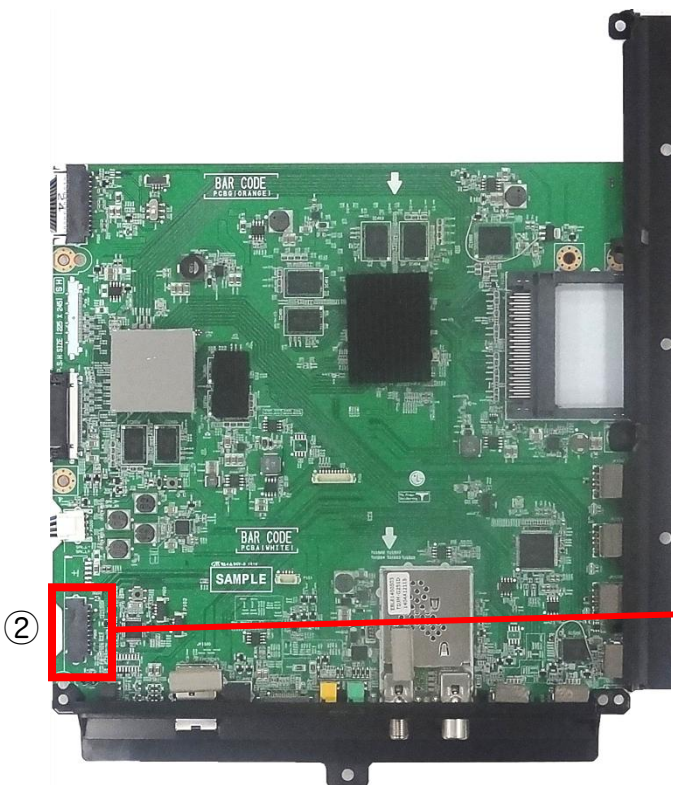

1	GND
2	+3.5V WOL
3	BT_RESET
4	USB_DM
5	NC
6	USB_DP
7	WOL
8	GND
9	SDA
10	GND
11	SCL
12	KEY1
13	GND
14	KEY2
15	IR
16	+3.5V_ST
17	LED_R
18	GND

## Checking order to check motion remote/wifi

Checking order

1. Check BT/Wifi cable condition between BT/Wifi assy & Main board.
2. Check the 3.5V on the terminal 16