

**PRELIMINARY**  
 some parametric limits are subject to change.

# M62493FP

DIGITAL SOUND CONTROLLER

## SINGLE CHIP ANALOG SOUND PROCESSOR

### DESCRIPTION

Home Audio, Equipment, Radio-Cassette, Recorder, TV.

### FEATURES

- 6-input selector
- Input ATT (-5dB) [ ON / OFF ]
- 5 band graphic equalizer ; 1 band (0,±3.8,±7.6,±13dB)  
     4 band (0,±3,±6,±10dB)
- Electric volume 32 steps (.dB to -76dB,- )
- Treble, Bass boost [ ON / OFF ]
- Surround (Using external delay) [ ON / OFF ]
- Vocal cancel [ ON / OFF]
- Multilingual record switching [ ON / OFF ]
- SW mode for control of DPL fields 2-lines for Rec output,  
     1-line for mute output.
- Input / output of adapter supporting karaoke control.
- Ability fair a single power,±power. (The outside COM power is necessary when uses single power.)
- Supper woofer output
- Output of spectrum analyzer (L+R)

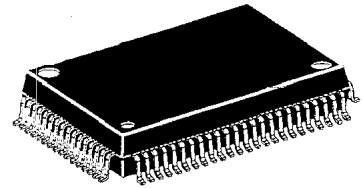

Outline 80P6N

Pitch ; 0.8 mm

Size ; 20.0 mmX14.0mmX  
 2.8mm

### RECOMMENDED OPERATING CONDITION

Power voltage range •••±4.5V to ±7.5V [9V to 15V (When uses single power) ]

### SYSTEM BLOCK DIAGRAM

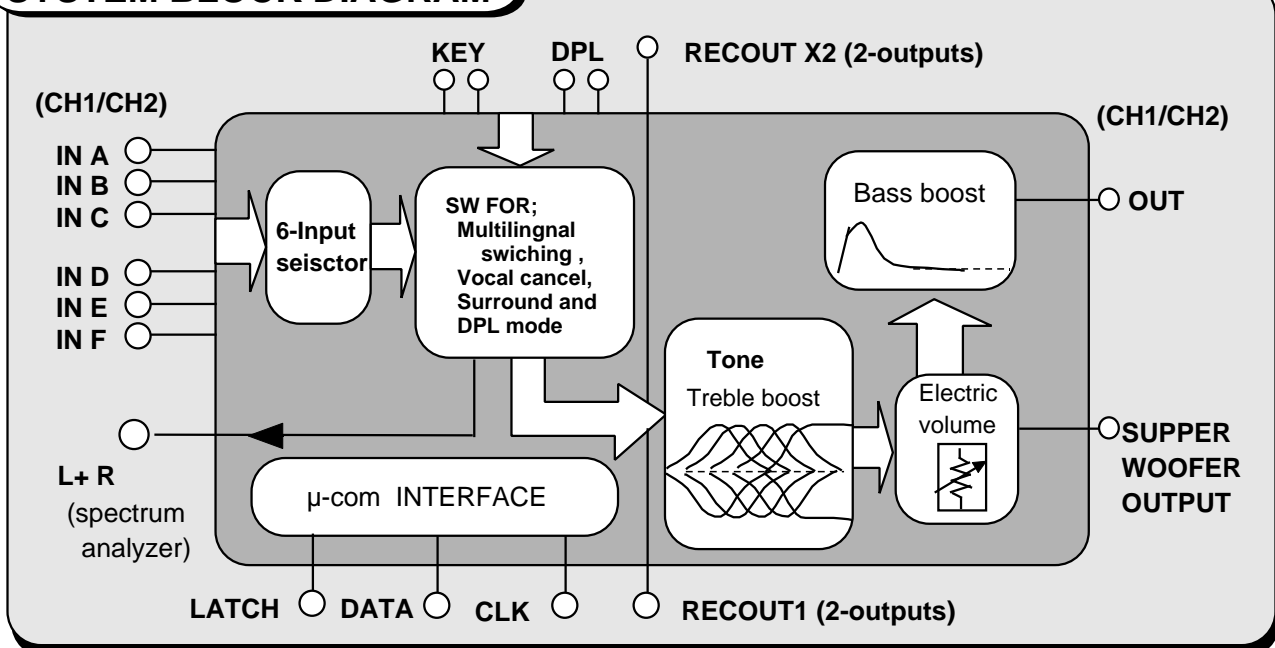

**PRELIMINARY**  
 some parametric limits are subject to change.

# M62493FP

DIGITAL SOUND CONTROLLER

## PIN CONFIGURATION AND IC INTERNAL BLOCK DIAGRAM

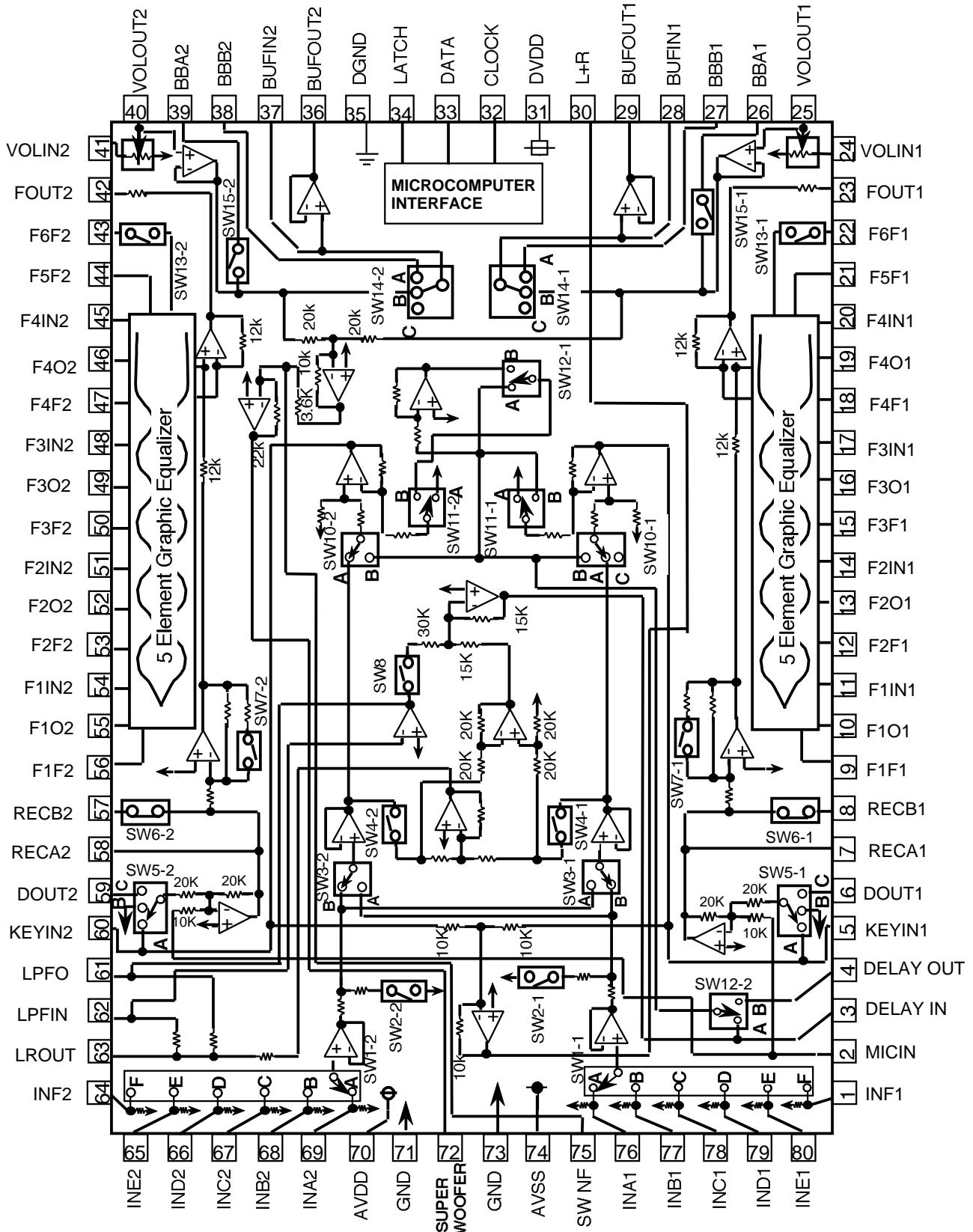

**PRELIMINARY**  
 some parametric limits are subject to change.

# M62493FP

DIGITAL SOUND CONTROLLER

## ABSOLUTE MAXIMUM RATINGS

System	Parameter	Condition	Ratings	Unit
AVDD,AVSS	Analog supply voltage		± 7.8	V
DVDD	Digital supply voltage		6.0	V
Pd	Power disipation	Ta 2°C	1250	mW
K	Thermal derating	Ta > 25°C Attached PC Board*	12.5	mW / °C
Topr	Operating temperature		-20 to +55	°C
Tstg	Storage temperature		-40 to +125	°C

### TYPICAL CHARACTERISTICS THERMAL DERATING

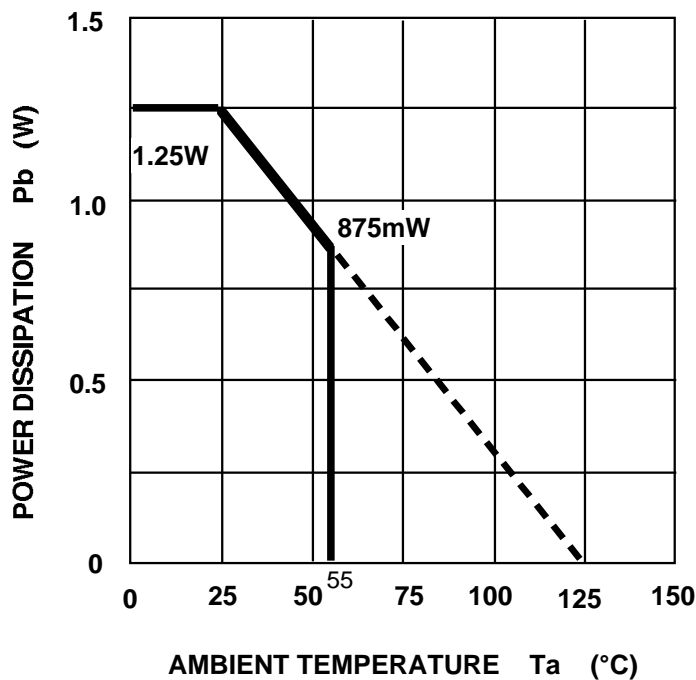

\*Note ; PC Board

- PC Board Size  
140mm X140mm
- PC Board Thickness  
1.6mm
- PC Board Material  
Epoxy
- Copper Film Thickness  
18µm
- Copper Foil Size  
0.25mm X50mm

## RECOMMENDED OPERATION CONDITION

( Ta = 25°C, unless otherwise noted )

Parameter	Symbol	Condition	Limits			Unit
			MIN	TYP	MAX	
Circuit current of analog positive power voltage	AVDD	Note.1	4.5	7.0	7.5	V
Circuit current of analog negative power voltage	AVSS	Note.1	-7.5	-7.0	-4.5	V
Circuit current of digital power voltage	DVDD	DVDD AVDD	4.5	5.0	5.5	V
High-level Input voltage	VIH		DVDD-0.7	—	VDD	V
Low-level Input voltage	VIL		0	—	DGND+0.7	V

Note 1 ; The sequence of the power supply is as follows.  
AVDD → AVSS → DVDD

## RELATIONSHIPS BETWEEN DATA AND CLOCK

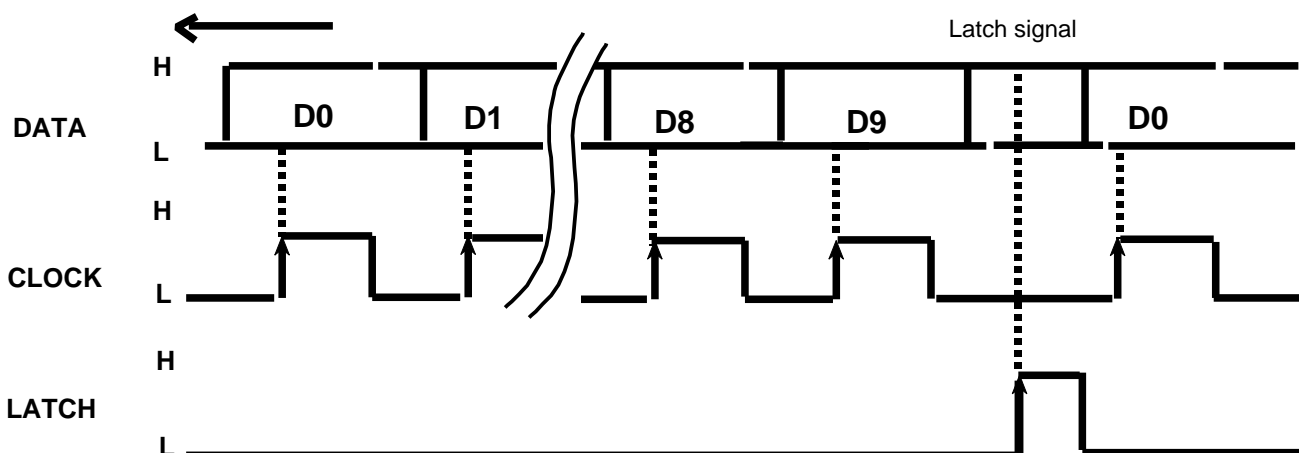

DATA reading mode ;  
The rising edge of the CLOCK signal.

LATCH reading mode ;  
The rising edge of the LATCH signal.

## CLOCK AND DATA TIMING

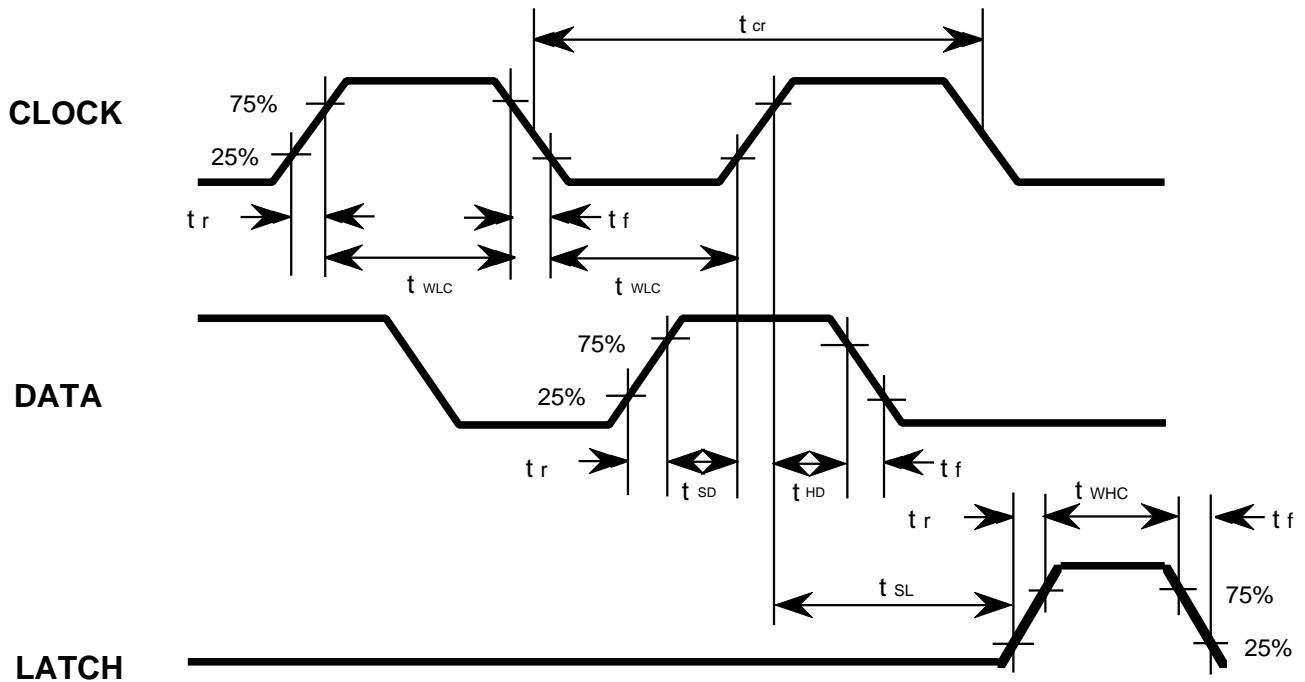

## DIGITAL BLOCK TIMING REGULATION

Symbol	Parameter	Limirs			Unit
		Min	typ	Max	
$t_{cr}$	CLOCK cycle time	4	-	-	μsec
$t_{wHC}$	CLOCK pulse width ("H"level)	1.6	-	-	
$t_{wLC}$	CLOCK pulse width ("L"level)	1.6	-	-	
$t_r$	CLOCK,DATA,LATCH rise time	-	-	0.4	
$t_f$	CLOCK,DATA,LATCH fall time	-	-	0.4	
$t_{SD}$	DATA setup time	0.8	-	-	
$t_{HD}$	DATA hold time	0.8	-	-	
$t_{SL}$	LATCH setup time	1	-	-	
$t_{WHL}$	LATCH pulse width	1.6	-	-	

## DATA INPUT FORMAT

5 kinds of input format option are available by changing slot setting of D5,D6,andD7.  
( When the IC is powered up, the internal setting are not fixed.)

← **Input direction**

**SLOTS OF INPUT  
FORMAT SELECTION**      **FIXATION BIT  
OF ADDRESS**

	DO1	D11	D21	D31	D41	D51	D6	D7	D8	D9
<b>(1)</b>	<b>Input ATT</b> 1 : -5dB 0 : 0dB	<b>Tone ATT</b> 1 : -6dB 0 : 0dB	<b>For the multiplex software</b> cf. (8) Setting code		<b>For the function software</b> cf. (11) Setting code		0	0	1	1
<b>(2)</b>	<b>For Input Selector</b> cf. (10) Setting code		<b>LOW BOOST</b> 1: ON sw15-1,2 : ON sw14-1,2: : A 0: OFF	<b>HI BOOST</b> 1: ON sw13-1,2 : ON 0: OFF	<b>SW12-2</b> 1 : B-SIDE 0 : A-SIDE		0	1	1	1
<b>(3)</b>	<b>For Tone Control</b> cf. (5) Setting code		<b>For Tone Boost / cut</b> cf. (6) Setting code			1	0	1	1	
<b>(4-1)</b>	<b>For Master Volume</b> cf. (7) Setting code					0	1	1	1	1
<b>(4-2)</b>	<b>For REC Input Signal</b> cf. (9) Setting code		<b>REC OUTPUT MUTE</b> 1 : ON sw6-1,2 : OFF 0 : OFF	0	0	1	1	1	1	1

**(5) Setting code  
( Tone control )**

	D03	D13	D23
Tone 1 (F1)	0	0	1
Tone 2 (F2)	0	1	0
Tone 3 (F3)	0	1	1
Tone 4 (F4)	1	0	0
Tone 5 (F5)	1	0	1

**(6) Setting code  
( Tone boost / cut and bass boost )**

	F1	F2 to F5	D33	D43	D53
<b>BOOST</b>	+0 dB	+0 dB	0	0	0
	+3.8 dB	+3 dB	0	0	1
	+7.6 dB	+6 dB	0	1	0
	+13 dB	+10 dB	0	1	1
<b>CUT</b>	-0 dB	-0 dB	1	0	0
	-3.8 dB	-3 dB	1	0	1
	-7.6 dB	-6 dB	1	1	0
	-13 dB	-10 dB	1	1	1

Note; Do not input other data than the above.

**PRELIMINARY**  
some parametric limits are subject to change.

# M62493FP

DIGITAL SOUND CONTROLLER

## (7) SETTING CODE ( MASTER VOLUME )

ATT	D04	D14	D24	D34	D44
- 0.0dB	0	0	0	0	0
- 2.0dB	1	0	0	0	0
- 4.0dB	0	1	0	0	0
- 6.0dB	1	1	0	0	0
- 8.0dB	0	0	1	0	0
- 10.0dB	1	0	1	0	0
- 12.0dB	0	1	1	0	0
- 14.0dB	1	1	1	0	0
- 16.0dB	0	0	0	1	0
- 18.0dB	1	0	0	1	0
- 20.0dB	0	1	0	1	0
- 22.0dB	1	1	0	1	0
- 24.0dB	0	0	1	1	0
- 26.0dB	1	0	1	1	0
- 28.0dB	0	1	1	1	0
- 30.0dB	1	1	1	1	0
- 32.0dB	0	0	0	0	1
- 34.0dB	1	0	0	0	1
- 36.0dB	0	1	0	0	1
- 38.0dB	1	1	0	0	1
- 40.0dB	0	0	1	0	1
- 42.0dB	1	0	1	0	1
- 44.0dB	0	1	1	0	1
- 48.0dB	1	1	1	0	1
- 52.0dB	0	0	0	1	1
- 56.0dB	1	0	0	1	1
- 60.0dB	0	1	0	1	1
- 64.0dB	1	1	0	1	1
- 68.0dB	0	0	1	1	1
- 72.0dB	1	0	1	1	1
- 76.0dB	0	1	1	1	1
-	1	1	1	1	1

## (8) MULTILINGUAL RECORD CODE

	D21	D31	SW3-1	SW3-2
NORMAL	0	0	B	B
CH1 only	0	1	B	A
CH2 only	1	0	A	B
CH1 / CH2 Exchange	1	1	A	A

## (9) REC INPUT SIGNAL CHANGE SETTING CODE

INPUT SIGNAL	D04-2	D14-2	SW5-1 SW5-2
THROUGH	0	0	A
DPL	1	0	C
GND	0	1	B

## (10) INPUT SELECTOR CODE

SELECTOR	D02	D12	D22
A	0	0	0
B	0	0	1
C	0	1	0
D	0	1	1
E	1	0	0
F	1	0	1

## (11) FUNCTION CODE

INPUT SIGNAL	D41	D51	sw4-1 sw4-2	sw8	sw10-1	sw10-2	sw11-1 sw11-2	sw12-1
NORMAL	0	0	OFF	OFF	A	A	A	A
VOCAL CANCELLATION	0	1	ON	ON	B	B	A	A
SURROUND	1	0	ON	OFF	A	A	B	B

Note ; Do not input other data than the above.

## ELECTRICAL CHARACTERISTICS

( Ta=25°C, AVdd=7V,AVss= -7V,DVdd=5V,f=1kHz,unless otherwise noted.  
Tone control and boost are set to 0dB )

### (1) POWER SUPPLY CHARACTERISTICS

Parameter	Symbol	Test conditions	Limits			Unit
			Min	typ	Max	
Circuit current (Analog+)	A <sub>Idd</sub>	Current at pin 70 with AVdd=7.0V,AVss= -7.0V No signal	—	50	58	mA
Circuit current (Analog-)	A <sub>Iss</sub>	Current at pin 74 with AVdd=7.0V,AVss= -7.0V No signal	-58	-50	—	mA
Circuit current (Digital)	D <sub>Idd</sub>	Current at pin 31 with DVdd=5.0V No signal	—	0.3	1.2	mA

### (2) INPUT / OUTPUT CHARACTERISTICS

Parameter	Symbol	Test conditions	Limits			Unit	
			Min	typ	Max		
Input resistance	R <sub>in</sub>	76pin,69Pin	30	60	120	K	
Max. input voltage	V <sub>IM</sub>	Input pin (76,64), Output pin (29,36) R <sub>L</sub> =10K , THD=1%	3.0	4.0	—	V <sub>rms</sub>	
Output pin voltage	V <sub>odc</sub>	29pin,36pin, No signal	-0.4	0.0	0.4	V	
	V <sub>recdc</sub>	7pin,58pin, No signal	-0.4	0.0	0.4	V	
Pass gain	G <sub>v</sub>	V <sub>in</sub> =1V <sub>rms</sub> ,FLAT,(76,69pin)-(29,36pin)gains.	-2.0	0	2.0	dB	
Max. attenuation	ATT	V <sub>o</sub> =1V <sub>rms</sub> ,29,36pin JIS-A filter	—	-85	-77	dB	
Output noise voltage	V <sub>ono</sub>	JIS-A filter No signal,R <sub>g</sub> =10K	(29,36 )pin	—	10.0	24	μV <sub>rms</sub>
	V <sub>recno</sub>	FLAT condition	(7,58 )pin	—	10.0	20	μV <sub>rms</sub>
Distortion factor	THD	29pin,36pin, BW=400 to 30kHz V <sub>o</sub> =0.5V <sub>rms</sub> , R <sub>L</sub> =10k	—	0.01	0.05	%	
	THD <sub>recA</sub>	7pin,58pin, BW=400 to 30kHz V <sub>o</sub> =0.5V <sub>rms</sub> , R <sub>L</sub> =30k	—	0.01	0.05	%	
	THD <sub>recB</sub>	8pin,57pin, BW=400 to 30kHz V <sub>o</sub> =0.5V <sub>rms</sub> , R <sub>L</sub> =51k	—	0.01	0.05	%	
Crosstalk between channels	CT	V <sub>o</sub> =0.5V <sub>rms</sub> , R <sub>L</sub> =10K ,JIS-A 29pin - 36pin gains R <sub>g</sub> =10K 2pin GND	—	-70	-55	dB	
	CT <sub>rec</sub>	V <sub>o</sub> =0.5V <sub>rms</sub> , R <sub>L</sub> =30K ,JIS-A 7pin - 58pin gains R <sub>g</sub> =10K 2pin GND	—	-70	-55	dB	



### (3) TONE CONTROL CHARACTERISTICS

Parameter	Symbol		Test condition	Limits			Unit	
				Min	typ	Max		
Voltage Gain (Tone control )	Gboost1	F1	3.8dB	f=1kHz, Vo=1Vms Input pin (6,59) - Output pin(23,42) gains.	2.3	3.8	5.3	dB
		F2 to 5	3 dB		1.5	3	4.5	
	Gboost2	F1	7.6dB		6.1	7.6	9.1	dB
		F2 to 5	6 dB		4.5	6	7.5	
	Gboost3	F1	13 dB		11.0	13	15.0	dB
		F2 to 5	10 dB		8.0	10	12.0	
	Gcut1	F1	-3.8dB		-5.3	-3.8	-2.3	dB
		F2 to 5	-3 dB		-4.5	-3	-1.5	
	Gcut2	F1	-7.6dB		-9.1	-7.6	-6.1	dB
		F2 to 5	-6 dB		-7.5	-6	-4.5	
	Gcut3	F1	-13dB		-15.0	-13	-11.0	dB
		F2 to 5	-10 dB		-12.0	-10	-8.0	
Voltage Gain (HI Boost)	Hboost		Input pin (6,59) - Output pin (23,42) gains.	6.5	8	9.5	dB	
Balance between channels	BALton		Each of boost,+10,-10dB conditions.	-1.5	0	+1.5	dB	

### (4) CH1 / CH2 MIX SIGNAL

Parameter		Symbol	Test conditions	Limits			Unit
				Min	typ	Max	
Supper woofer output	Gain	GvSW	Condition same as Gv RL=30k	8	10	12	dB
	Distortion factor	THDSW	BW=400 to 30kHz Vo=0.5Vrms , RL=30K	—	0.03	0.15	%
	Output noise voltage	VnoSW	Condition same as Vono No signal, JIS-A filter	—	70	170	μVrms
L+R Output voltage		GvLR	Condition same as Gv RL=51k	-2	0	2	dB

**PRELIMINARY**  
 some parametric limits are subject to change.

# M62493FP

DIGITAL SOUND CONTROLLER

## MASTER VOLUME CIRCUIT

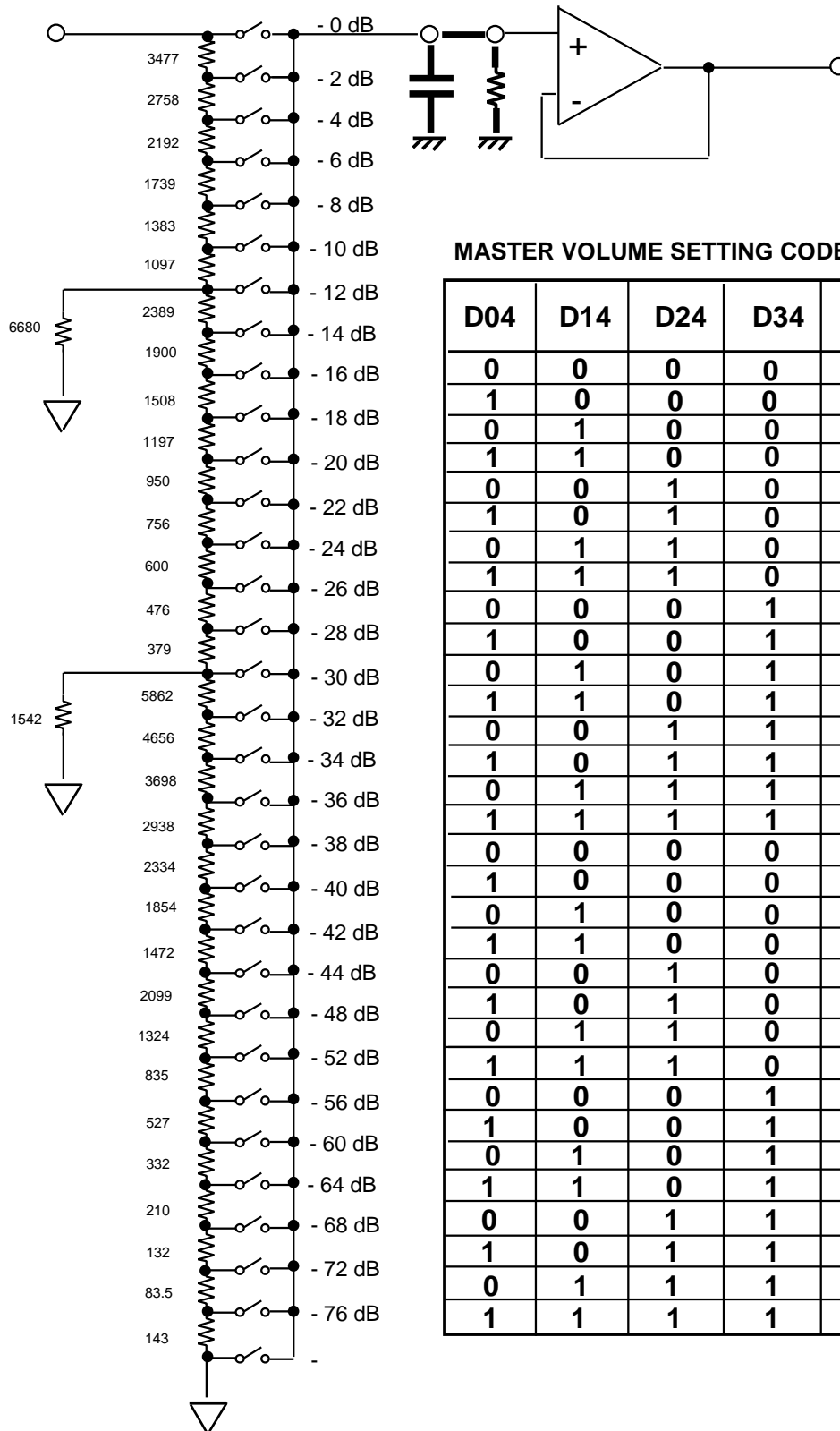

MASTER VOLUME SETTING CODE

D04	D14	D24	D34	D44	ATT
0	0	0	0	0	- 0.0dB
1	0	0	0	0	- 2.0dB
0	1	0	0	0	- 4.0dB
1	1	0	0	0	- 6.0dB
0	0	1	0	0	- 8.0dB
1	0	1	0	0	- 10.0dB
0	1	1	0	0	- 12.0dB
1	1	1	0	0	- 14.0dB
0	0	0	1	0	- 16.0dB
1	0	0	1	0	- 18.0dB
0	1	0	1	0	- 20.0dB
1	1	0	1	0	- 22.0dB
0	0	1	1	0	- 24.0dB
1	0	1	1	0	- 26.0dB
0	1	1	1	0	- 28.0dB
1	1	1	1	0	- 30.0dB
0	0	0	0	1	- 32.0dB
1	0	0	0	1	- 34.0dB
0	1	0	0	1	- 36.0dB
1	1	0	0	1	- 38.0dB
0	0	1	0	1	- 40.0dB
1	0	1	0	1	- 42.0dB
0	1	1	0	1	- 44.0dB
1	1	1	0	1	- 48.0dB
0	0	0	1	1	- 52.0dB
1	0	0	1	1	- 56.0dB
0	1	0	1	1	- 60.0dB
1	1	0	1	1	- 64.0dB
0	0	1	1	1	- 68.0dB
1	0	1	1	1	- 72.0dB
0	1	1	1	1	- 76.0dB
1	1	1	1	1	-

**PRELIMINARY**  
 Notice ; This is not a final specification.  
 some parametric limits are subject to change.

# M62493FP

## FUNCTION DESCRIPTION

### (1) TONE CONTROLLER EQUIVALENT CIRCUIT

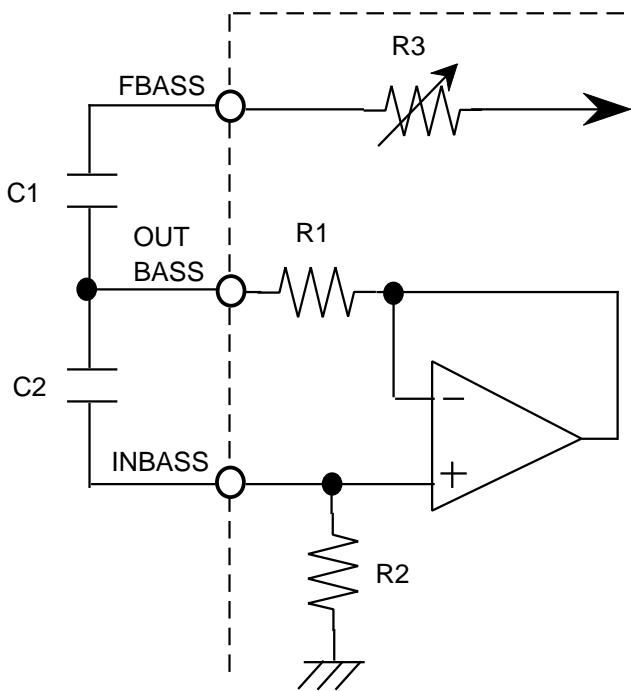

Center frequency

$$f_0 = 1 / 2 \sqrt{C1 \cdot C2 \cdot R1 \cdot R2} \text{ [Hz]}$$

$$Q = \sqrt{C2 (R1 \cdot R2) / C1 (R1 + R3)^2}$$

	F1	F2	F3	F4	F5
R1	1.49k	1.49k	1.49k	1.49k	—
R2	306k	306k	306k	306k	—

Fig.1 ; The equivalent circuit of tone controller.

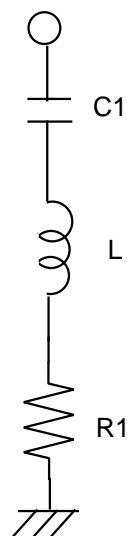

Fig.2 is equivalent to Fig.1.  
 To convert component constants,  
 the equation below is used.

$$L = C2 \cdot R1 \cdot R2$$

Fig.2 ; The equivalent circuit using L

**PRELIMINARY**  
 Notice ; This is not a final specification.  
 some parametric limits are subject to change.

# M62493FP

## (2) VOCAL CUT L.P.F EQUIVALENT CIRCUIT

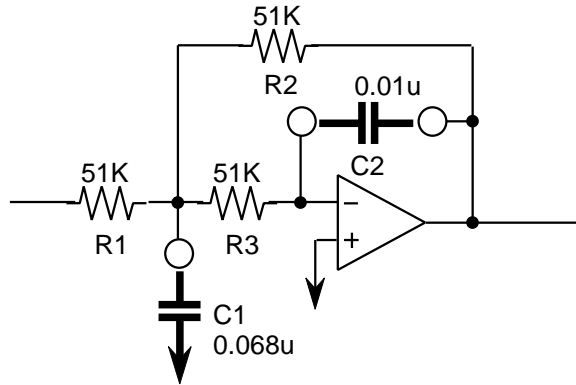

$$T(s) = \frac{A\omega_0^2}{s^2 + \frac{\omega_0}{Q}s + \omega_0^2}$$

$$Q = \frac{\sqrt{R_1 \cdot R_2 \cdot C_1 \cdot C_2}}{R_2 \cdot C_2 + R_1 \cdot C_2 + \frac{R_1 \cdot R_2}{R_3} C_2}$$

$$\left\{ \begin{array}{l} A = -\frac{R_1}{R_2} \\ \frac{\omega_0}{Q} = \frac{1}{C_1} \left( \frac{1}{R_1} + \frac{1}{R_2} + \frac{1}{R_3} \right) \\ \omega_0^2 = \frac{1}{R_1 \cdot R_2 \cdot C_1 \cdot C_2} \end{array} \right.$$

At the time of ;  $R_1=R_2=R_3$  ,  
 Become ;  $A = -1$

$$f_c = \frac{1}{2 \sqrt{R_1 \cdot R_2 \cdot C_1 \cdot C_2}}$$

$$Q = \frac{1}{3} \sqrt{\frac{C_1}{C_2}} \quad (\text{Using } Q < Z)$$

At the time of ;  $R_1=R_2=R_3=51k$  ,  
 $C_1=0.068\mu F, C_2=0.01\mu F$   
 Become ;  $f_c \div 120\text{Hz}$   
 $Q \div 0.87$

Pay attention to In-Output turning over, because using turnig over mode.

**PRELIMINARY**

Notice ; This is not a final specification.  
some parametric limits are subject to change.

# M62493FP

DIGITAL SOUND CONTROLLER

### (3) BASS BOOST EQUIVALENT CIRCUIT

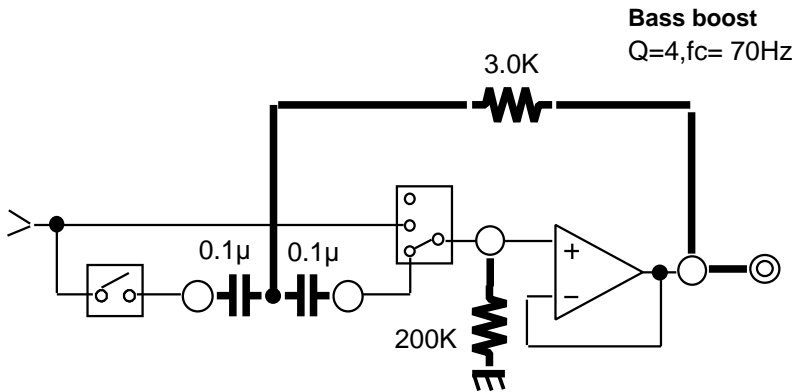

Original return type 2 dimensions HPF circuit of Bass boost.

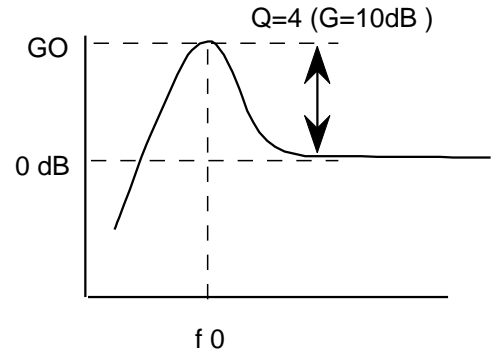

Amplitude characteristic of HPF (Reference)

Q	GO
1	0 to 1 dB
2	6 dB
4	10 dB
5	13 dB
10	20 dB

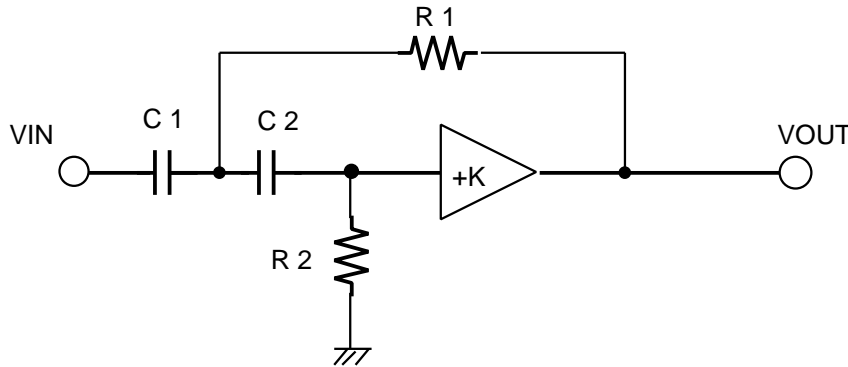

Communication function is ;

$$\frac{V_{OUT}}{V_{IN}} = \frac{Ks^2}{s^2 + s \left[ \frac{1}{R_2C_1} + \frac{1}{R_2C_2} + (1-K) \frac{1}{R_1C_1} \right] + \frac{1}{R_1R_2C_1C_2}}$$

$$\omega_0^2 = \frac{1}{R_1R_2C_1C_2}$$

$$Q = \frac{1}{\sqrt{\frac{R_1C_1}{R_2C_2}} + \sqrt{\frac{R_1C_2}{R_2C_1}} + (1-K)\sqrt{\frac{R_2C_2}{R_1C_1}}}$$

Bass boost consists of original return type 2 dimensions HPF circuit of upper figure.  
To the following showing an example of method of design calculation of Bass boost.

At the time of ;  
 $C_1 = C_2 = C_f$ ,  $K = +1$

The upper expression becomes ;  
 $R_f = 1 / (\omega_0 C_f) \dots (1)$

$R_1 = R_f / 2Q \dots (2)$

$R_2 = 2Q R_f \dots (3)$

When cut off frequency is 70Hz ,  
 $\omega_0 = 2\pi \times 70\text{Hz}$ ,  $Q=4$ , condition.

At the time of ;  $C_1=C_2=C_f=0.1\mu\text{F}$   
 From ; (1),(2),(3)  
 Become ;  $R_f=22.7\text{K}$   
 $R_1 = 2.84\text{K}$   
 $R_2 = 182\text{K}$

$R_1, R_2$  is about 3.0K , 200K

**PRELIMINARY**  
 Notice ; This is not a final specification.  
 some parametric limits are subject to change.

# M62493FP

## (4) VOCAL CANCELLATION EQUIVALENT CIRCUIT

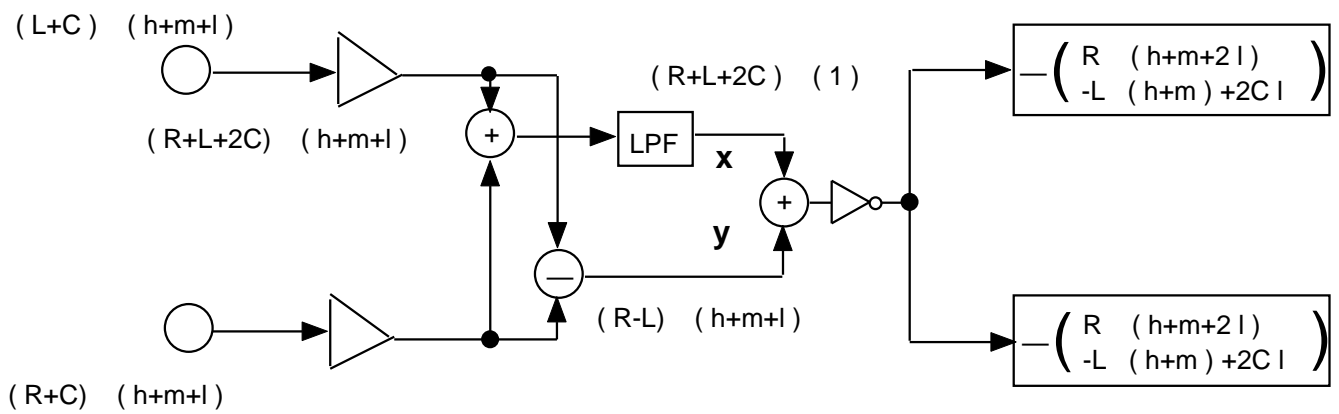

## (5) SURROUND EQUIVALENT CIRCUIT

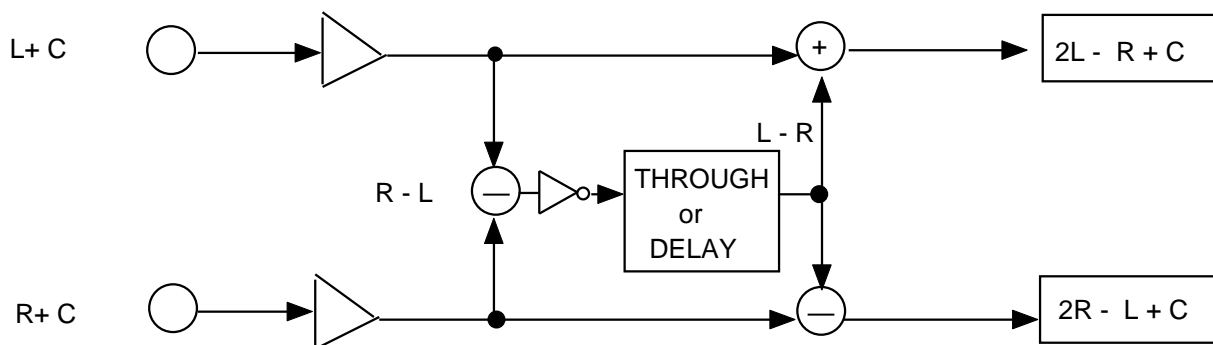

**PRELIMINARY**

Notice ; This is not a final specification.  
some parametric limits are subject to change.

**M62493FP**

DIGITAL SOUND CONTROLLER

**SIGNAL COMMUNICATION BLOCK CIRCUIT (NO.1)**

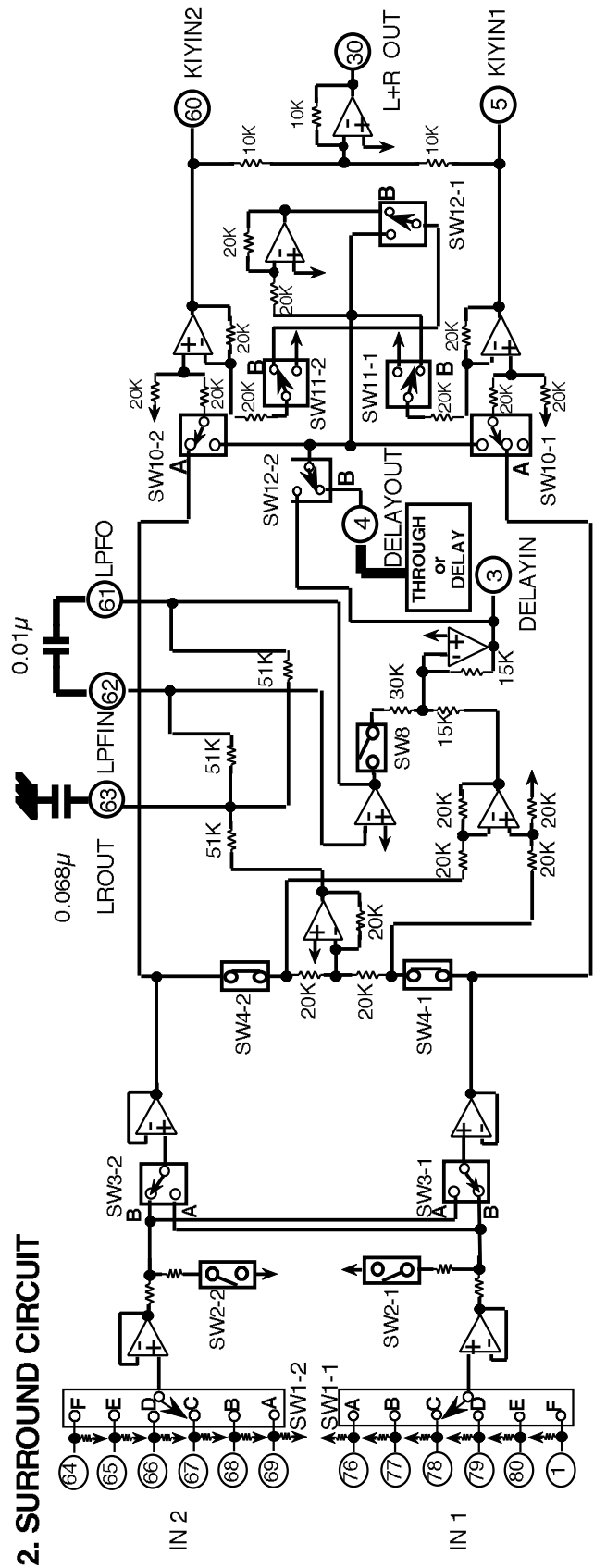
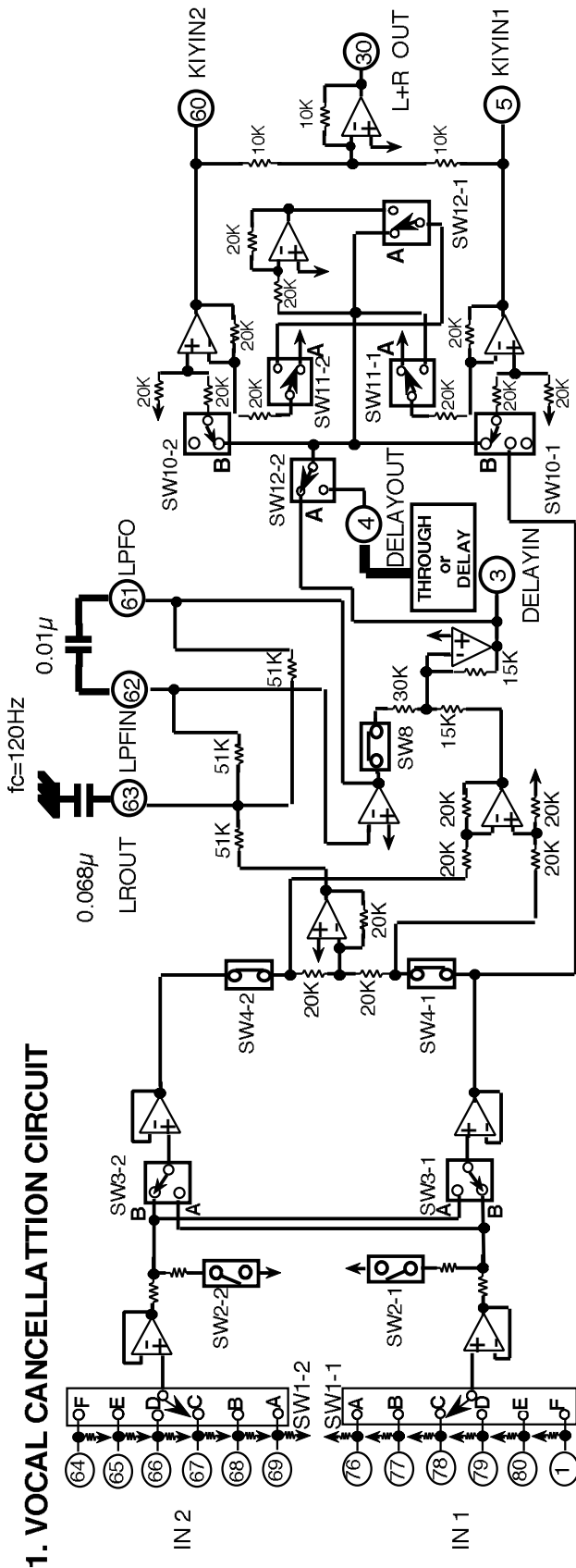

**PRELIMINARY**

Notice ; This is not a final specification.  
some parametric limits are subject to change.

MITSUBISHI SOUND PROCESSORS

**M62493FP**

DIGITAL SOUND CONTROLLER

**SIGNAL COMMUNICATION BLOCK CIRCUIT ( No.2 )**

**3. TONE CURCUIT ( CH1 )**

Each of frequency +10dB to -10dB, change

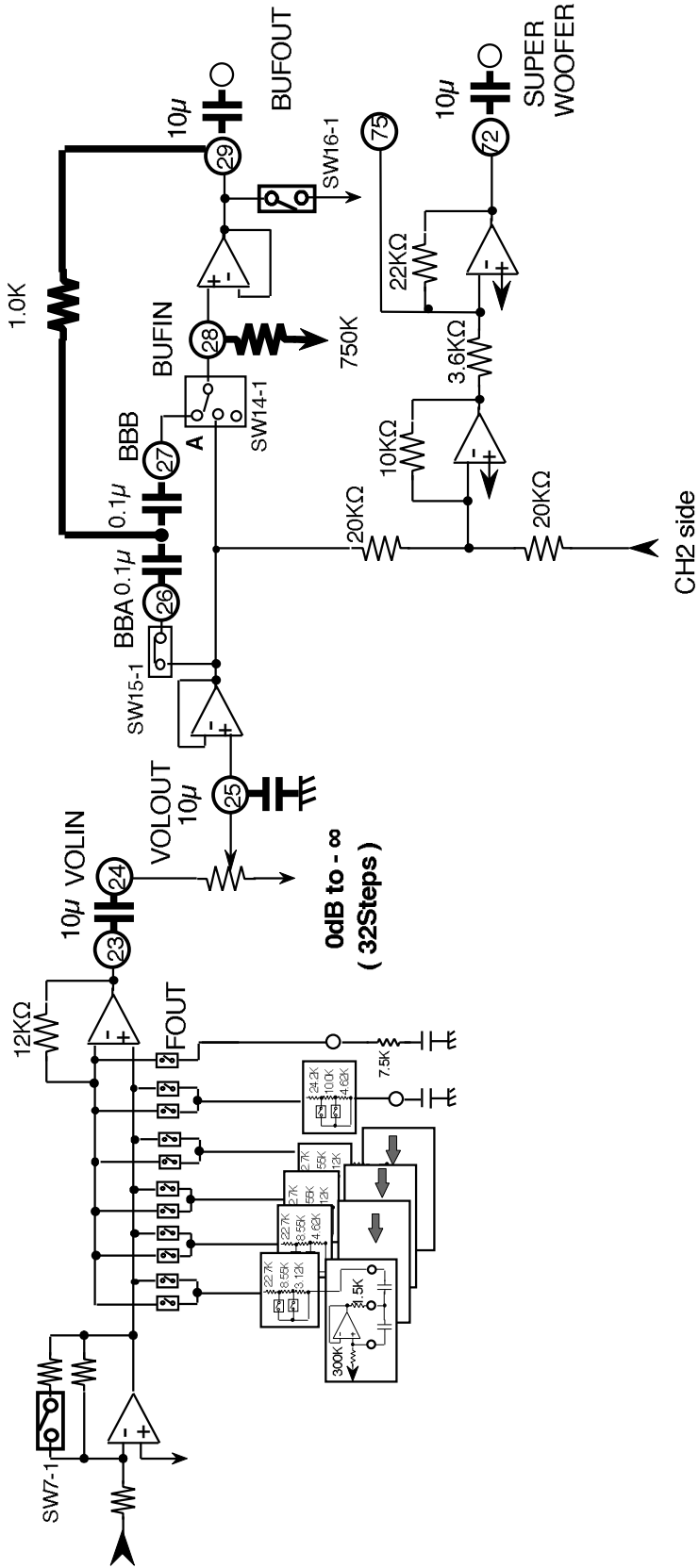



**PRELIMINARY**  
 Notice ; This is not a final specification.  
 some parametric limits are subject to change.

MITSUBISHI SOUND PROCESSORS

# M62493FP

DIGITAL SOUND CONTROLLER

## REC INPUT CHANGE CIRCUIT

(1) THROUGH MODE

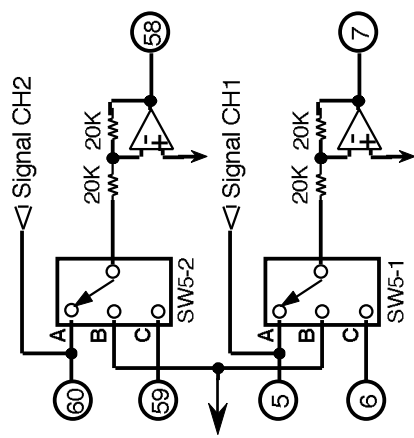

(2) DPL MODE

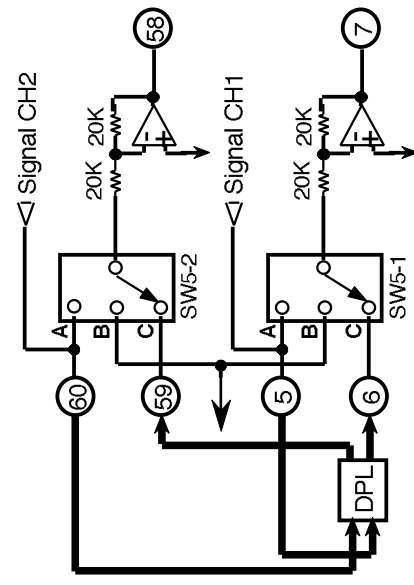

**PRELIMINARY**

Notice ; This is not a final specification.  
some parametric limits are subject to change.

MITSUBISHI SOUND PROCESSORS

# M62493FP

DIGITAL SOUND CONTROLLER

## APPLICATION CIRCUIT (±Power)

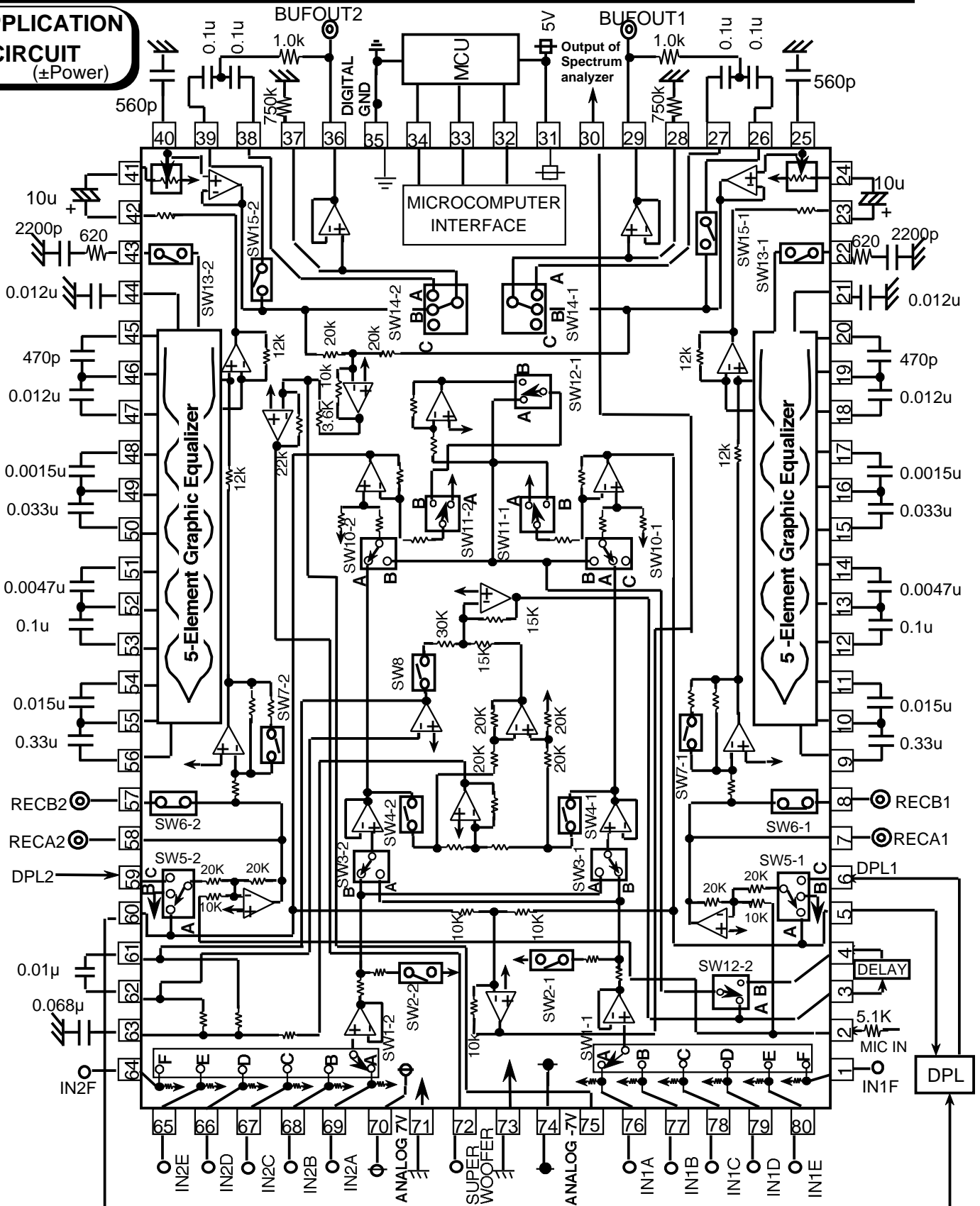

This datasheet has been download from:

[www.datasheetcatalog.com](http://www.datasheetcatalog.com)

Datasheets for electronics components.