



MICROWAVE OVEN

BASIC: M1736N
MODEL: MW73VR
MODEL CODE: MW73VR/BWT

SERVICE *Manual*

MICROWAVE OVEN

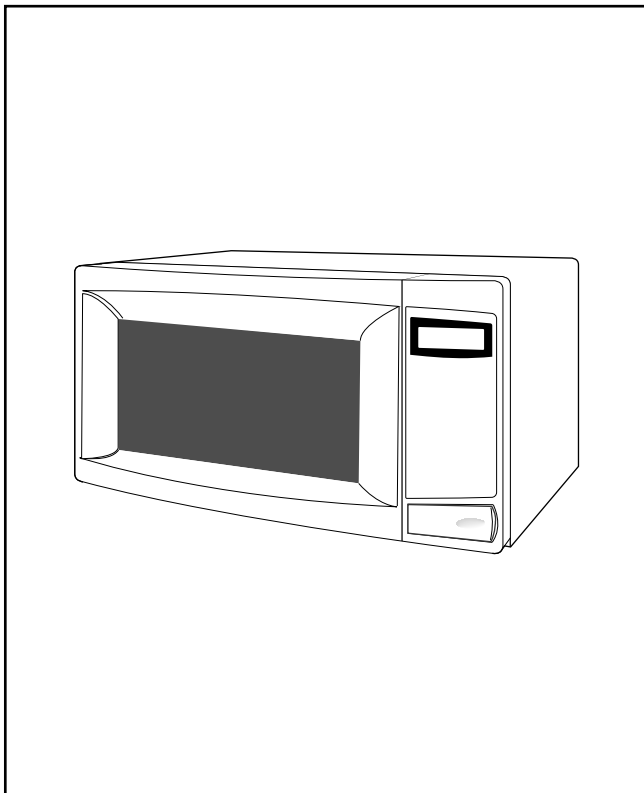

CONTENTS

1. Precaution
2. Product Specification
3. Disassembly and Reassembly
4. Troubleshooting
5. Exploded Views and Part List
6. PCB Diagrams
7. Wiring Diagrams
8. Schematic Diagrams

Refer to the service manual in the GSPN(see rear cover) for the more information.

• Contents

1. Precaution	3
1-1 Safety precautions	4
1-2 Special High Voltage Precautions	5
2. Specifications	6
2-1 Features	6
2-2 Table of Specifications	6
2-3 Accessory	7
3. Disassembly and Reassembly	8
3-1 Disassembly of Magnetron, Motor Assembly and Lamp	8
3-2 Replacement of High Voltage Trancefomer	10
3-3 Replacement of Door Assembly	12
3-4 Replacement of Drive Motor	13
3-5 Replacement of Control Circuit Board	14
4. Troubleshooting	15
4-1 Error Code Numbering Rule	15
4-2 Error Code List	15
4-3 Electrical Malfunction	17
5. Exploded Views and Parts List	33
5-1 Exploded Views	33
5-2 Main Parts List	34
5-3 Door Parts List	35
5-4 Control Parts List	36
5-5 Standard Parts List	37
6. PCB Diagrams	38
6-1 PCB Diagrams	38
7. Wiring Diagrams	39
7-1 Wiring Diagrams	39
8. Schematic Diagrams	41
8-1 Schematic Diagrams	41

1. Precaution



PRECAUTIONS TO BE OBSERVED BEFORE AND DURING SERVICING TO AVOID POSSIBLE EXPOSURE TO EXCESSIVE MICROWAVE ENERGY

- (a) Do not operate or allow the oven to be operated with the door open.
- (b) Make the following safety checks on all ovens to be serviced before activating the magnetron or other microwave source, and make repairs as necessary:
 - (1) Interlock operation,
 - (2) proper door closing,
 - (3) seal and sealing surfaces (arcing, wear, and other damage),
 - (4) damage to or loosening of hinges and latches,
 - (5) evidence of dropping or abuse.
- (c) Before turning on microwave power for any service test or inspection within the microwave generating compartments, check the magnetron, wave guide or transmission line, and cavity for proper alignment, integrity, and connections.
- (d) Any defective or misadjusted components in the interlock, monitor, door seal, and microwave generation and transmission systems shall be repaired, replaced, or adjusted by procedures described in this manual before the oven is released to the owner.
- (e) A Microwave leakage check to verify compliance with the Federal performance standard should be performed on each oven prior to release to the owner.

1. Precaution

Follow these special safety precautions. Although the microwave oven is completely safe during ordinary use, repair work can be extremely hazardous due to possible exposure to microwave radiation, as well as potentially lethal high voltages and currents.

1-1 Safety precautions ()

1. All repairs should be done in accordance with the procedures described in this manual. This product complies with Federal Performance Standard 21 CFR
2. Microwave emission check should be performed prior to servicing if the oven is operative.
3. If the oven operates with the door open :Instruct the user not to operate the oven and contact the manufacturer and the center for devices and radiological health immediately.
4. Notify the Central Service Center if the microwave leakage exceeds 5 mW/cm².
5. Check all grounds.
6. Do not power the MWO from a “2-prong” AC cord. Be sure that all of the built-in protective devices are replaced. Restore any missing protective shields.
7. When reinstalling the chassis and its assemblies, be sure to restore all protective devices, including: nonmetallic control knobs and compartment covers.
8. Make sure that there are no cabinet openings through which people --particularly children--might insert objects and contact dangerous voltages. Examples: Lamp hole, ventilation slots.
9. Inform the manufacturer of any oven found to have emission in excess of 5 mW/cm² ,Make repairs to bring the unit into compliance at no cost to owner and try to determine cause. Instruct owner not to use oven until it has been brought into compliance.
CENTRAL SERVICE CENTER
10. Service technicians should remove their watches while repairing an MWO.
11. To avoid any possible radiation hazard,replace parts in accordance with the wiring diagram. Also, use only the exact replacements for the following parts: Primary and secondary interlock switches, interlock monitor switch.
12. If the fuse is blown by the Interlock Monitor Switch: Replace all of the following at the same time: Primary, door sensing switch and power relay, as well as the Interlock Monitor Switch. The correct adjustment of these switches is described elsewhere in this manual. Make sure that the fuse has the correct rating for the particular model being repaired.
13. Design Alteration Warning: Use exact replacement parts only, i.e.,only those that are specified in the drawings and parts lists of this manual. This is especially important for the Interlock switches, described above. Never alter or add to the mechanical or electrical design of the MWO. Any design changes or additions will void the manufacturer’s warranty. Always unplug the unit’s AC power cord from the AC power source before attempting to remove or reinstall any component or assembly.
14. Never defeat any of the B+ voltage interlocks. Do not apply AC power to the unit (or any of its assemblies) unless all solid-state heat sinks are correctly installed.
15. Some semiconductor (“solid state”) devices are easily damaged by static electricity. Such components are called Electrostatically Sensitive Devices (ESDs). Examples include integrated circuits and field-effect transistors. Immediately before handling any semiconductor components or assemblies, drain the electrostatic charge from your body by touching a known earth ground.
16. Always connect a test instrument’s ground lead to the instrument chassis ground before connecting the positive lead; always remove the instrument’s ground lead last.
17. When checking the continuity of the witches or transformer, always make sure that the power is OFF, and one of the lead wires is disconnected.
18. Components that are critical for safety are indicated in the circuit diagram by shading,  or .
19. Use replacement components that have the same ratings, especially for flame resistance and dielectric strength specifications. A replacement part that does not have the same safety characteristics as the original might create shock, fire or other hazards.
NOTE : Connect the oven to a 20A. When connecting the oven to a 15A,make sure that circuit breaker can operate.

1. Precaution

1-2 Special High Voltage Precautions

1. High Voltage Warning Do not attempt to measure any of the high voltages --this includes the filament voltage of the magnetron. High voltage is present during any cook cycle. Before touching any components or wiring, always unplug the oven and discharge the high voltage capacitor (See Figure 1-1)
2. The high-voltage capacitor remains charged about 30 seconds after disconnection. Short the negative terminal of the high-voltage capacitor to to the oven chassis. (Use a screwdriver.)
3. High voltage is maintained within specified limits by close-tolerance, safety-related components and adjustments. If the high voltage exceeds the specified limits, check each of the special components.

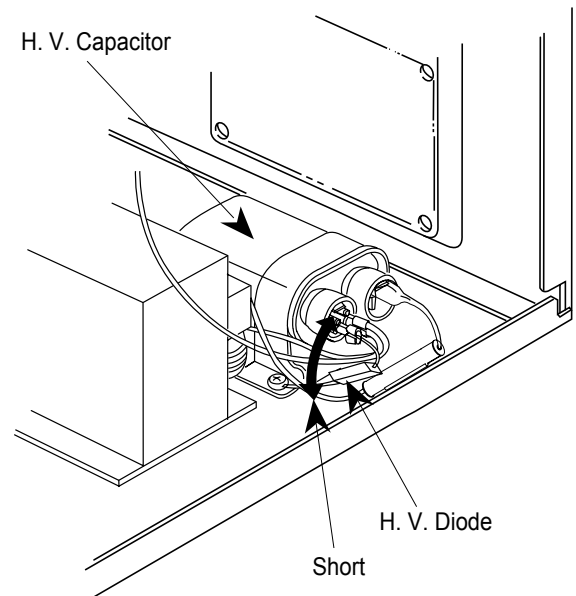

PRECAUTION

There exists HIGH VOLTAGE ELECTRICITY with high current capabilities in the circuits of the HIGH VOLTAGE TRANSFORMER secondary and filament terminals. It is extremely dangerous to work on or near these circuits with the oven energized.

DO NOT measure the voltage in the high voltage circuit including filament voltage of magnetron.



PRECAUTION

Servicemen should remove their watches whenever working close to or replacing the magnetron.



PRECAUTION

Never touch any circuit wiring with your hand nor with uninsulated tool during operation.

2. Specifications

2-1 Features

Product Features
- Handle Design
- Tact & Membrane Control Panel
- 20L Compact Size MWO

2-2 Table of Specifications

Items		Model	
		Model Basic	Model New
MODEL NAME		M1736N	MW73VR
Power Source		230V ~ 50Hz AC	230V ~ 50Hz AC
Power consumption	Microwave	1300W	1150W
Output Power		100W / 800W (IEC-705)	100W / 800W (IEC-705)
Operating Frequency		2450MHz	2450MHz
Magnetron		OM75S(31)	OM75S(31)
Cooling Method		Cooling fan motor	Cooling fan motor
Dimensions (W x H x D)	Outside	489 x 275 x 361mm	489 x 275 x 361mm
	Oven cavity	306 x 211 x 320mm	306 x 211 x 320mm
Volume		20Liter	20Liter
Weight	Net	12.5Kg	12.5Kg

2. Specifications



2-3 Accessory

Item	Description	Code No.	Q'ty
 A line drawing of a coupler, which is a circular component with a central hole and four protruding tabs around the perimeter.	Coupler	DE67-00140A	1
 A line drawing of an Assy-Guide Roller, which is an oval-shaped component with two small circular rollers on opposite ends.	Assy-Guide Roller	DE97-00193B	1
 A line drawing of a Tray-cooking component, which is a circular tray with a raised rim and a central area containing several small circular holes.	Tray-cooking	DE74-00027A	1

3. Disassembly and Reassembly

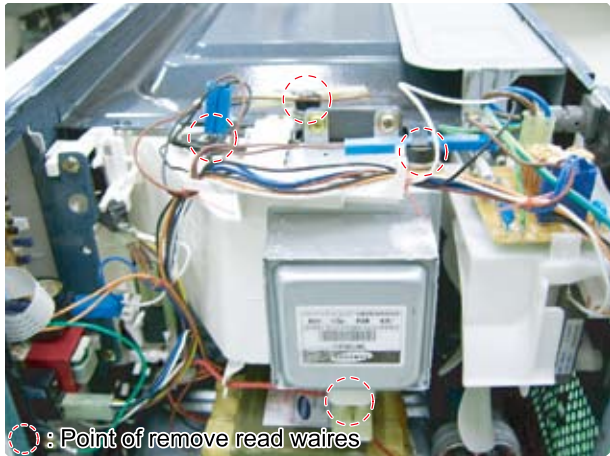
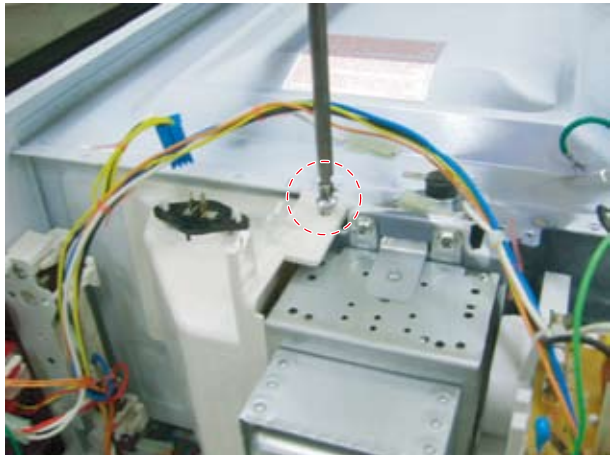

3-1 Disassembly of Magnetron, Motor Assembly and Lamp

Remove the magnetron including the shield case, permanent magnet, choke coils and capacitors (all of which are contained in one assembly)

Parts	Explanation Photo	Explanation
Magnetron, Motor Assembly and Lamp	 <p>○ : Point of remove read waires</p>	1. Disconnect all lead wires from the magnetron and lamp.
		2. Remove a screw securing air cover.
		3. Remove the air cover.

3. Disassembly and Reassembly

3-1 Disassembly of Magnetron, Motor Assembly and Lamp

Parts	Explanation Photo	Explanation
Magnetron, Motor Assembly and Lamp		4. Remove screws securing the magnetron to the wave guide.
		5. Take out the magnetron very carefully.
		6. Remove two screws from the back panel. 7. Take out the fan motor.

3. Disassembly and Reassembly

3-1 Disassembly of Magnetron, Motor Assembly and Lamp

Parts	Explanation Photo	Explanation
Magnetron, Motor Assembly and Lamp		<p>8. Remove the oven lamp from hole of air cover.</p>

NOTE1: When removing the magnetron, make sure that its antenna does not hit any adjacent parts, or it may be damaged.

NOTE2: When replacing the magnetron, be sure to remount the magnetron gasket in the correct position and make sure the gasket is in good condition.

3-2 Replacement of High Voltage Trancefomer

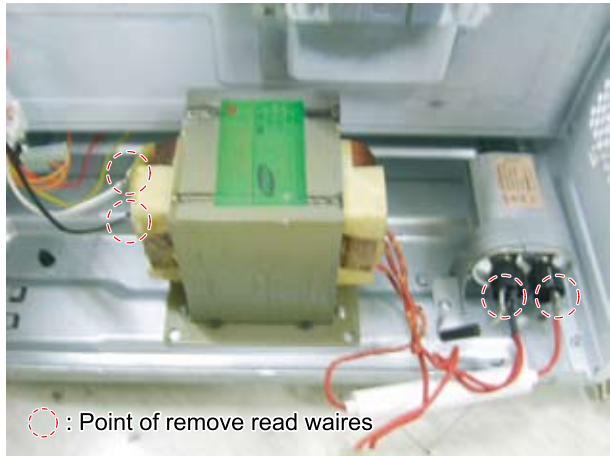
Parts	Explanation Photo	Explanation
High Voltage Transformer		<p>1. Discharge the high voltage capacitor.</p>
	 <p>○ : Point of remove read waires</p>	<p>2. Disconnect all the leads.</p>

3. Disassembly and Reassembly

3-2 Replacement of High Voltage Transformer

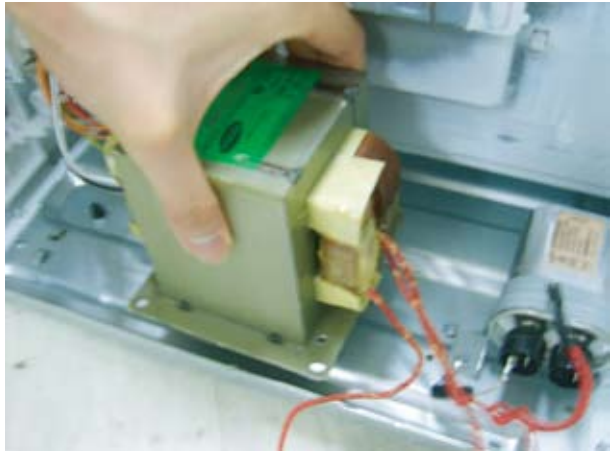
Parts	Explanation Photo	Explanation
High Voltage Transformer	 <p>Base plate bottom</p> <p>○ : Point of remove screws</p>	<p>3. Remove the mounting bolts.</p>
		<p>4. Replace the High Voltage Transformer</p> <p>5. After replace, reconnect the leads correctly and firmly.</p>

 **PRECAUTION**

Servicemen should remove their watches whenever working close to or replacing the magnetron.



 **PRECAUTION**

There exists HIGH VOLTAGE ELECTRICITY with high current capabilities in the circuits of the HIGHVOLTAGE TRANSFORMER secondary and filament terminals. It is extremely dangerous to work on or near these circuits with the oven energized.

DO NOT measure the voltage in the high voltage circuit including filament voltage of magnetron.

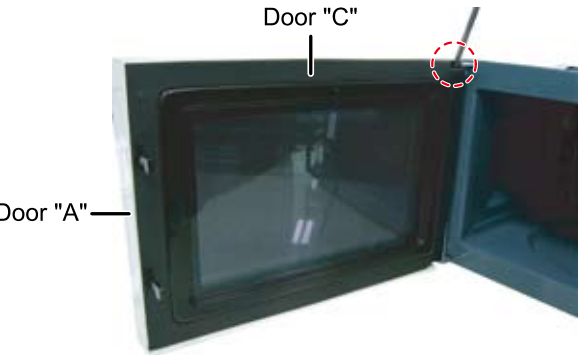

3. Disassembly and Reassembly

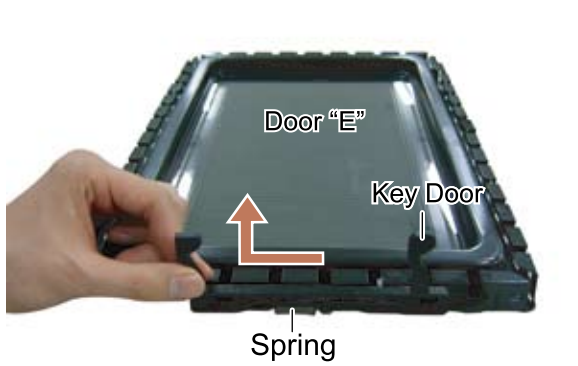
3-3 Replacement of Door Assembly

Parts	Disassembly Photo	Explanation
Removal of Door "C"		<p>Insert flat screwdriver into the gap between Door "A" and Door "C" to remove Door "C". Be careful when handling Door "C" because it is fragile. Then remove the door assembly.</p>
Removal of Door Assembly		<p>Lift up the Door Assembly from Cavity.</p>
Removal of Door "E"		<p>Following the procedure as shown in the figure, insert and bend a thin metal plate between Door "E" and Door "A" until you hear the 'tick' sound.</p> <ul style="list-style-type: none"> • Insertion depth of the thin metal plate should be 0.5mm or less.
Removal of Key Door & Spring		<p>Remove pin hinge from Door "E" Detach spring from Door "E" and key door.</p>

3. Disassembly and Reassembly

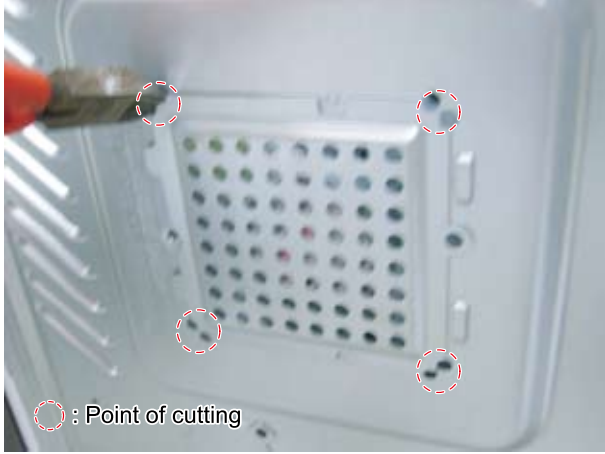
3-4 Replacement of Drive Motor

Parts	Explanation Photo	Explanation
Drive Motor		<ol style="list-style-type: none"> 1. Take out the glass tray, guide roller from oven cavity, disconnect power. 2. Remove turn table motor cover from case bottom. <p>CAUTION : Remove sharp edge after cover removal.</p>
Drive Motor		<ol style="list-style-type: none"> 3. Disconnect leads from motor. 4. Remove the screws securing motor to bottom of oven cavity.
Drive Motor		<ol style="list-style-type: none"> 6. Lift out the motor. 5. When replacing the motor, be sure to remount it in the correct position. <p>NOTE : The shaft of motor should fit tip coupler.</p>
	<p align="center">COVER FIXING SCREW : MATCHINE SCREW(6006-001170)</p>	<ol style="list-style-type: none"> 6. When reassemble a drive motor cover. give a turn in a 180° and fix with a screw. <p>NOTE : Bring the spare screw from service center.</p>

3. Disassembly and Reassembly

3-5 Replacement of Control Circuit Board

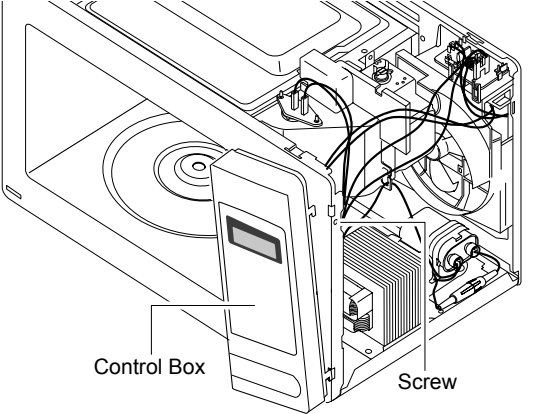
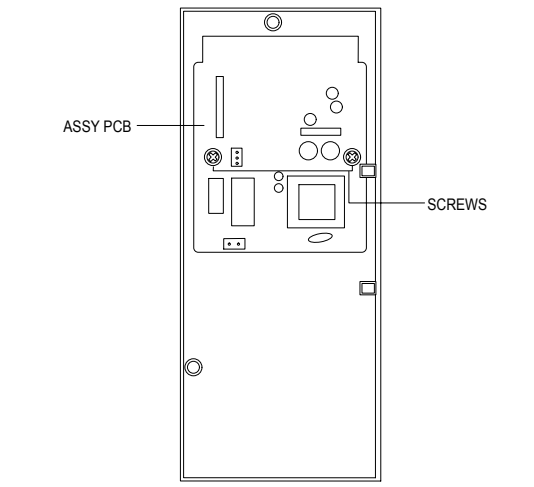
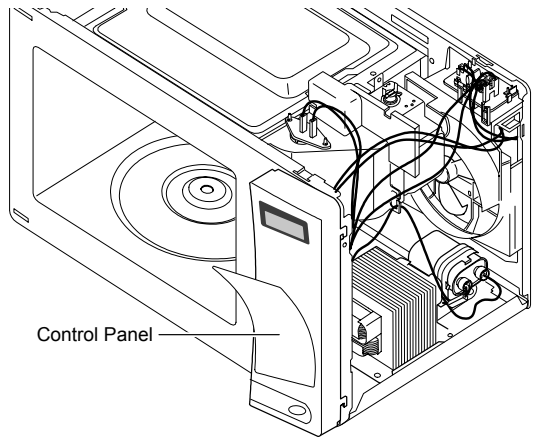
Parts	Explanation Photo	Explanation
<p>Removal of Control Box Assembly</p>		<ol style="list-style-type: none"> 1. Be sure to ground any static electric charge in your body and never touch the control circuit. 2. Disconnect the connectors from the control circuit board. 3. Remove screws securing the control box assembly. 4. Remove the screw securing the ground tail of the keyboard.
<p>Removal of Ass'y P.C.B Assembly</p>		<ol style="list-style-type: none"> 1. Pull the lever end of the plastic fastener and remove the Flexible Printed Circuit(FPC) of membrane panel. 2. Remove screws securing the control circuit board. 3. Lift up the control circuit board from the Ass'y control box. 4. When reconnecting the FPC connector, make sure that the holes on the connector are properly engaged with the hooks on the Plastic Fastener.
<p>Removal of Window Display & Membrane Panel</p>		<ol style="list-style-type: none"> 1. Window display should not be disassembled as its mounting tabs will be broken. If repair work is difficult, replace with Ass'y control panel. 2. The membrane key board is attached to the escutcheon base with double faced adhesive tape. Therefore, applying hot air such as using of hair dryer is recommended for smoother removal. 3. When installing new membrane key board, make sure that the surface of escutcheon base is cleaned sufficiently so that any problems (shorted contacts or uneven surface) can be avoided.

4. Troubleshooting

4-1 Error Code Numbering Rule

1. ERROR CODE NUMBERING RULE is applied to a microwave oven and an oven.(CMO, OTR, Grill, Convection, Commercial etc.)
2. All sensors and devices have their own number. ex) Gas Sensor = 1, Temp. Sensor = 2, ...
3. Of each device, No.1 and No.2 refer to "Open Error" (not sensed) and "Short Error", respectively.
4. This numbering rule has been applied to models to have been developed since January, 1, 2005. (But, GE or Customize model are excluded.)

E - 1 1

DEVICE	ERROR CASE
0- Others	1- Open
1- Gas Sensor	2- Short
2- Temp. Sensor	•
3- Weight Sensor	•
4- Easy/PH Sensor	•
5- EEPROM	
	•
	•
	•

4-2 Error Code List

Gas Sensor

Error Code	Gas Sensor Error Case (E-1X)	Solution	Page
E-11	Open	Check Sensor part ,connection of sensor housing and PCB's connector.	17 Page
E-12	Short		18 Page
E-13	T1 Max Time Error		19 Page
E-14	Dry Up / No Load	Insert food and restart.	

Temp Sensor

Error Code	Temp. Sensor Error Case (E-2X)	Solution	Page
E-21	Open	Check sensor part and connection of sensor housing and PCB's connector.	17 Page
E-22	Short		18 Page
E-23	T1 Max Time Error (Preheating not completed)	Check heater.	25 Page
E-24	Over temperature error		27 Page
E-25	In case abnormal temperature is sensed at Micro Cook	Cool down set and restart.	28 Page
E-26	In case the temperature is not over the fixed AD in first 3 minutes after cooking by heater starts.	Check sensor and heater.	25 Page

Eeprom Error

Error Code	EEPROM Error Case (E-5X)	Solution	Page
E-51	Open (Sense Failure)	Replace EEPROM and restart.	24 Page
E-53	Read/Write Error		
E-54	Zero not to be set		

4. Troubleshooting

Weight Sensor

Error Code	Gas Sensor Error Case (E-1X)	Solution	Page
E-31	Open (When value of HEX is above "FF" for 5 seconds)	Check Sensor.	17 Page
E-32	Short		18 Page
E-33	In case the initial value of HEX is under "14" for 30 seconds while a weight sensor in operation.		21 Page
E-34	In case the initial value of K calculated by a weight sensor is above and under "±28" as value of HEX.		
E-35	In case the value of A is "-" as a weight sensor calculates.		22 Page
E-36	In case the door opens during sensor cooking.	Cancel the present mode and restart from the beginning.	

Easy/Ph Sensor

Error Code	Easy/PH Sensor Error Case (E4)	Solution	Page
E-41	Open	Check Sensor.	17 Page
E-42	Short		18 Page
E-43	T1 Max Time Error		19 Page
E-44	Dry Up	Insert food and restart.	19 Page
E-45	Cooling Error (3minutes)	Remove moisture from sensor and restart.	23 Page
E-46	Primary Open Error(3minutes)	Check Sensor.	17 Page
E-47	The door opens during cooking	Cancel the present mode and restart from the beginning.	22 Page

Humidity Sensor

Error Code	Humidity Sensor Error Case (E-6X)	Solution	Page
E-61	Open	Check Sensor.	17 Page
E-62	Short		18 Page
E-63	T1 Max Time Error		19 Page

Others

Error Code	Others (E-0X, Letter)	Solution	Page
-SE-	Key Short Error (10 seconds)	Turn off set and restart.	20 Page
E-02	Cooking Time Setting Over Error (MWO)	Check each mode's setting time.	26 Page
E-03	Cooking Time Setting Over Error (Grill)		
E-04	Cooking Time Setting Over Error (Convection)		
E-05	Cooking Time Setting Over Error (Combination)	Check Swing heater's motor and connector.	29 Page
E-06	It fails to sense that the swing heater has stopped for 20 seconds during cooking.		

4. Troubleshooting

4-3 Electrical Malfunction

4-3-1 Sensor Open Error

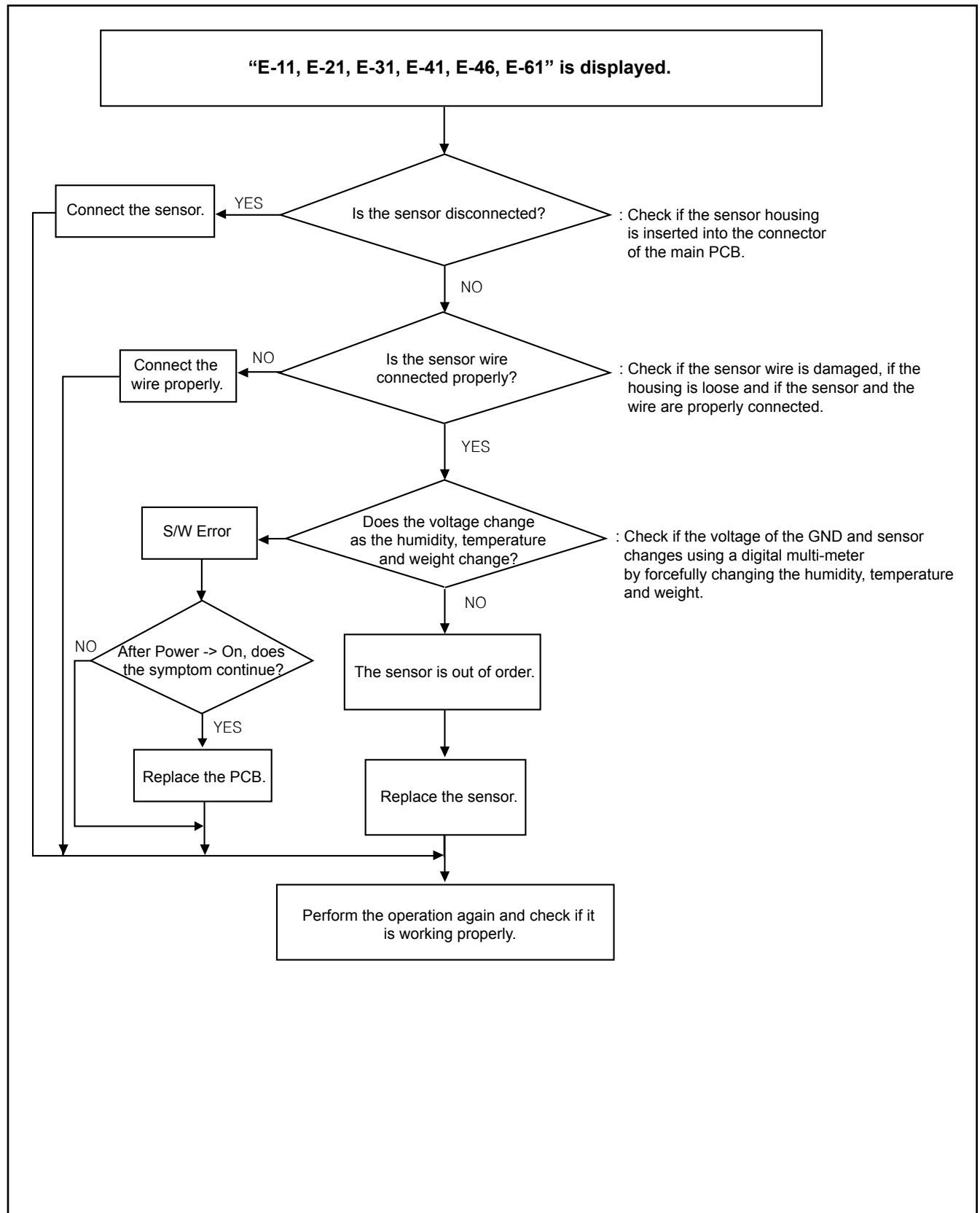

4. Troubleshooting

4-3-2 Sensor Short Error

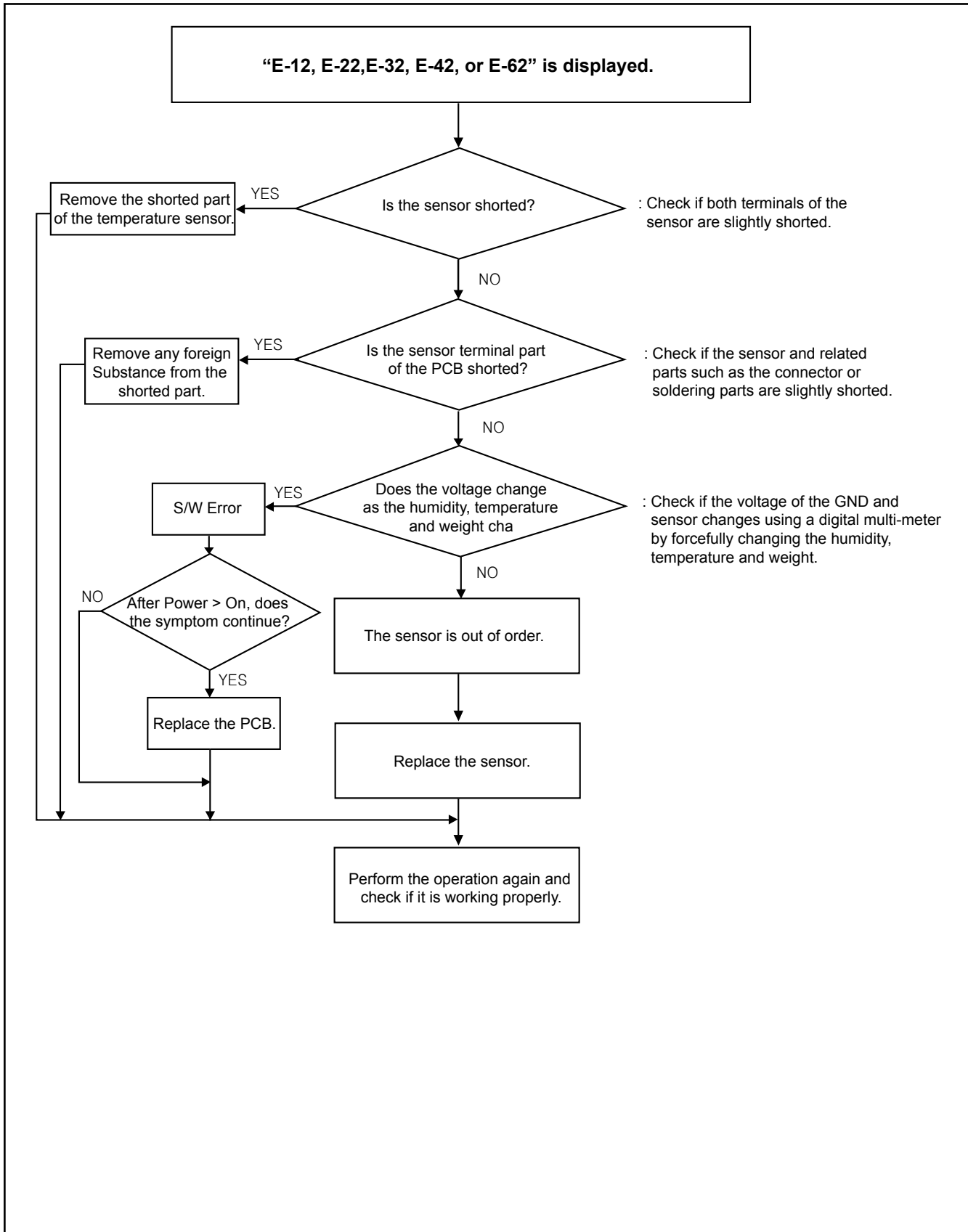

4. Troubleshooting

4-3-3 Sensor Max Time Error

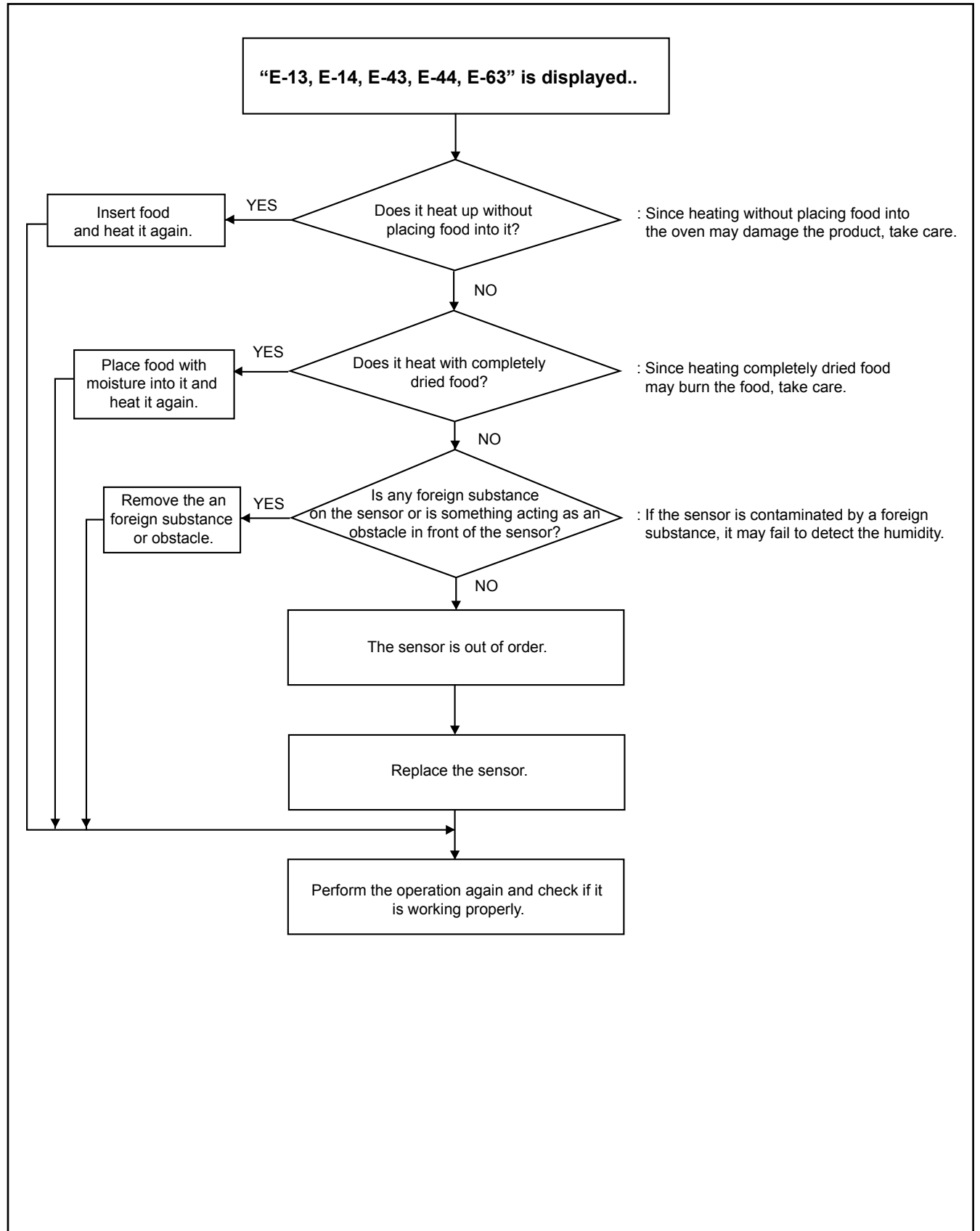

4. Troubleshooting

4-3-4 Key Short Error

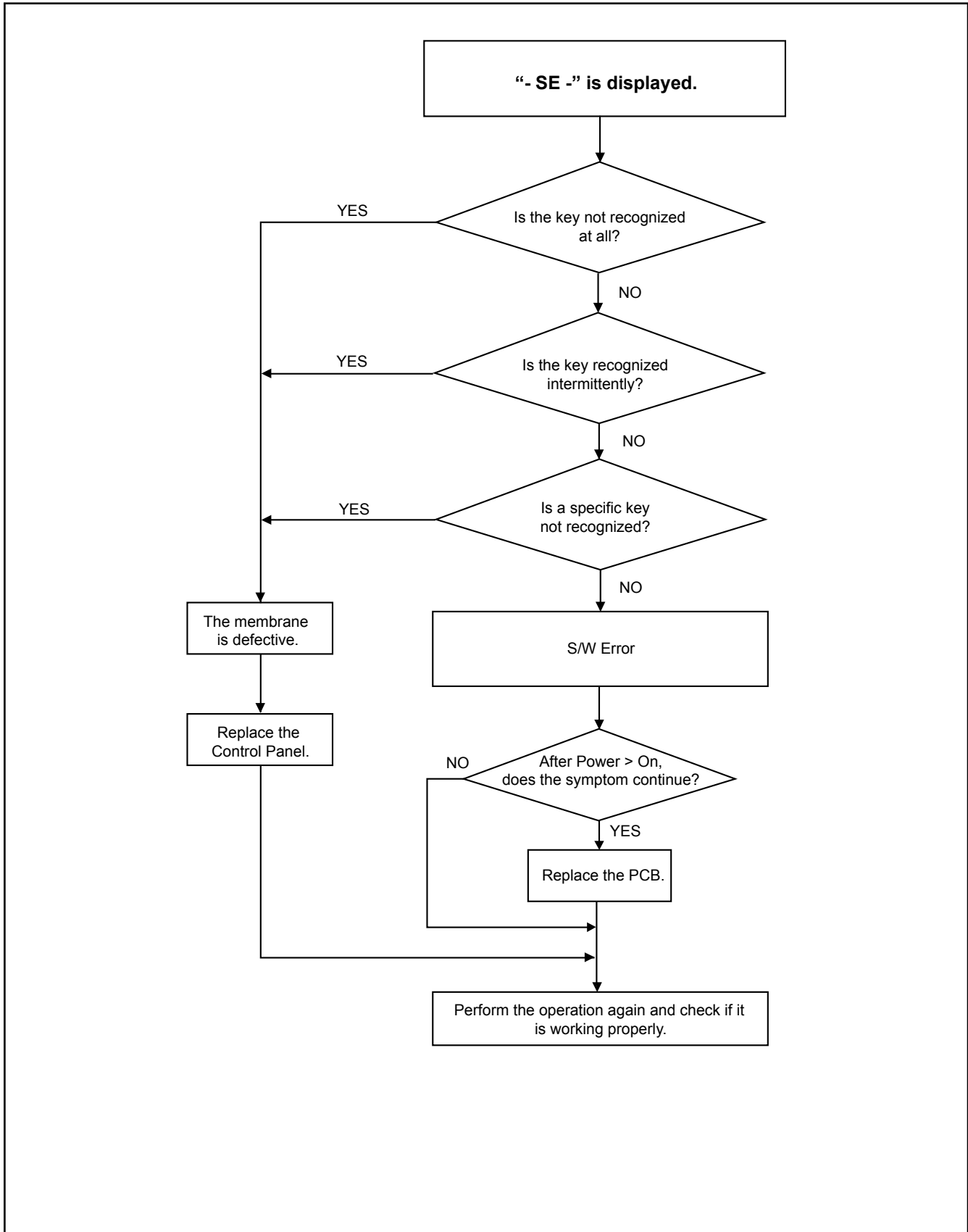

4. Troubleshooting

4-3-5 Weight Sensor Error

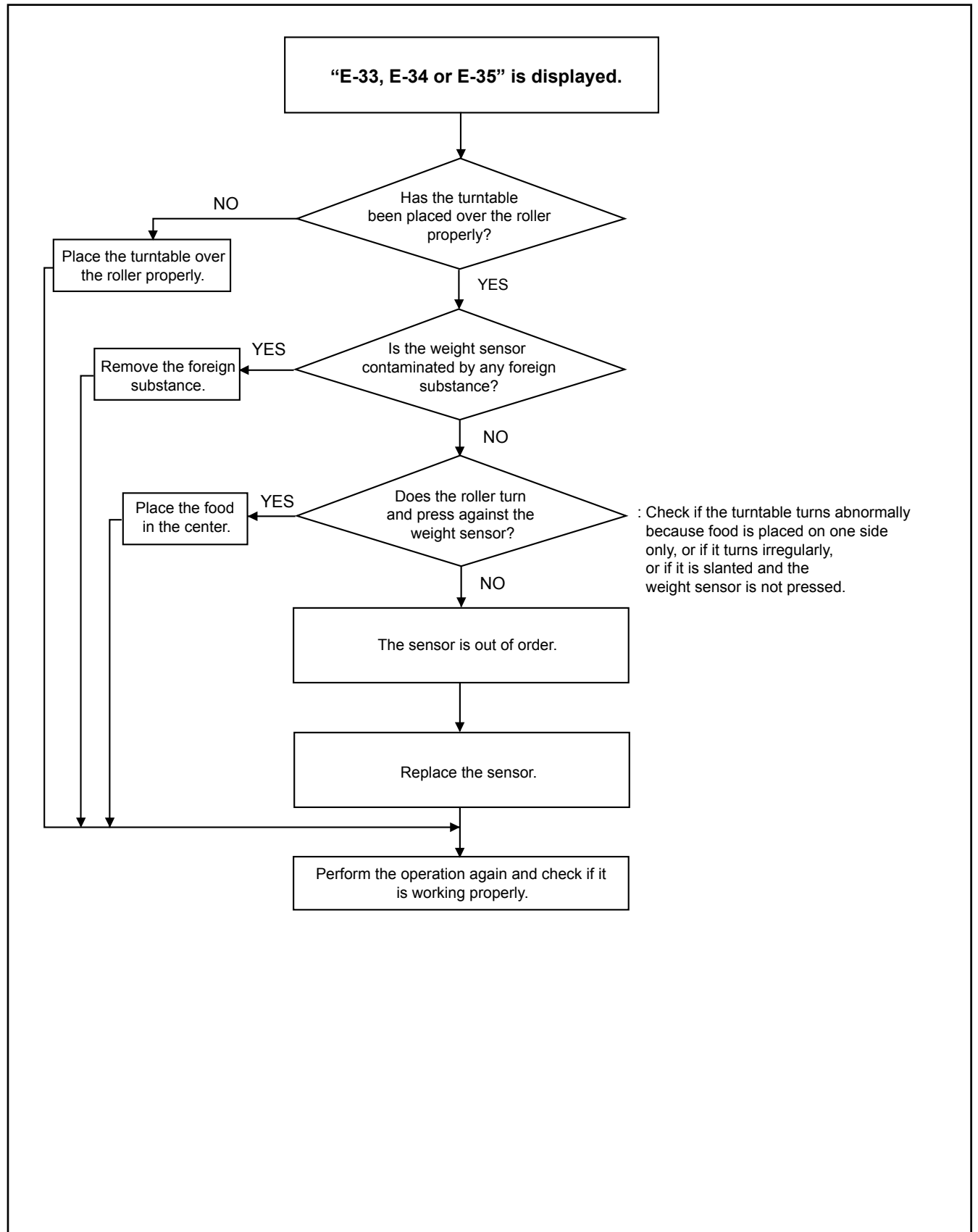

4. Troubleshooting

4-3-6 Weight Sensor Error

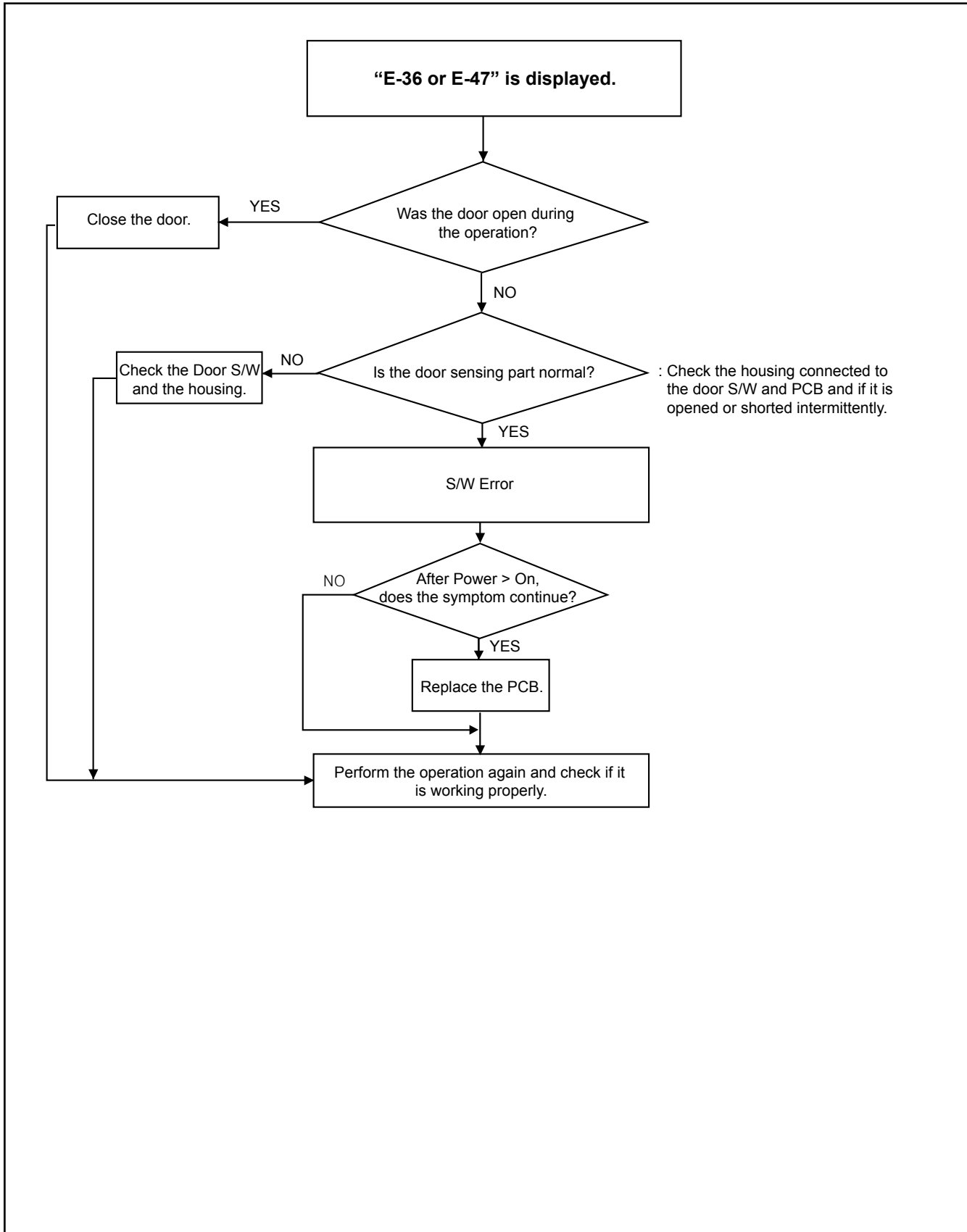

4. Troubleshooting

4-3-7 Cooling Error

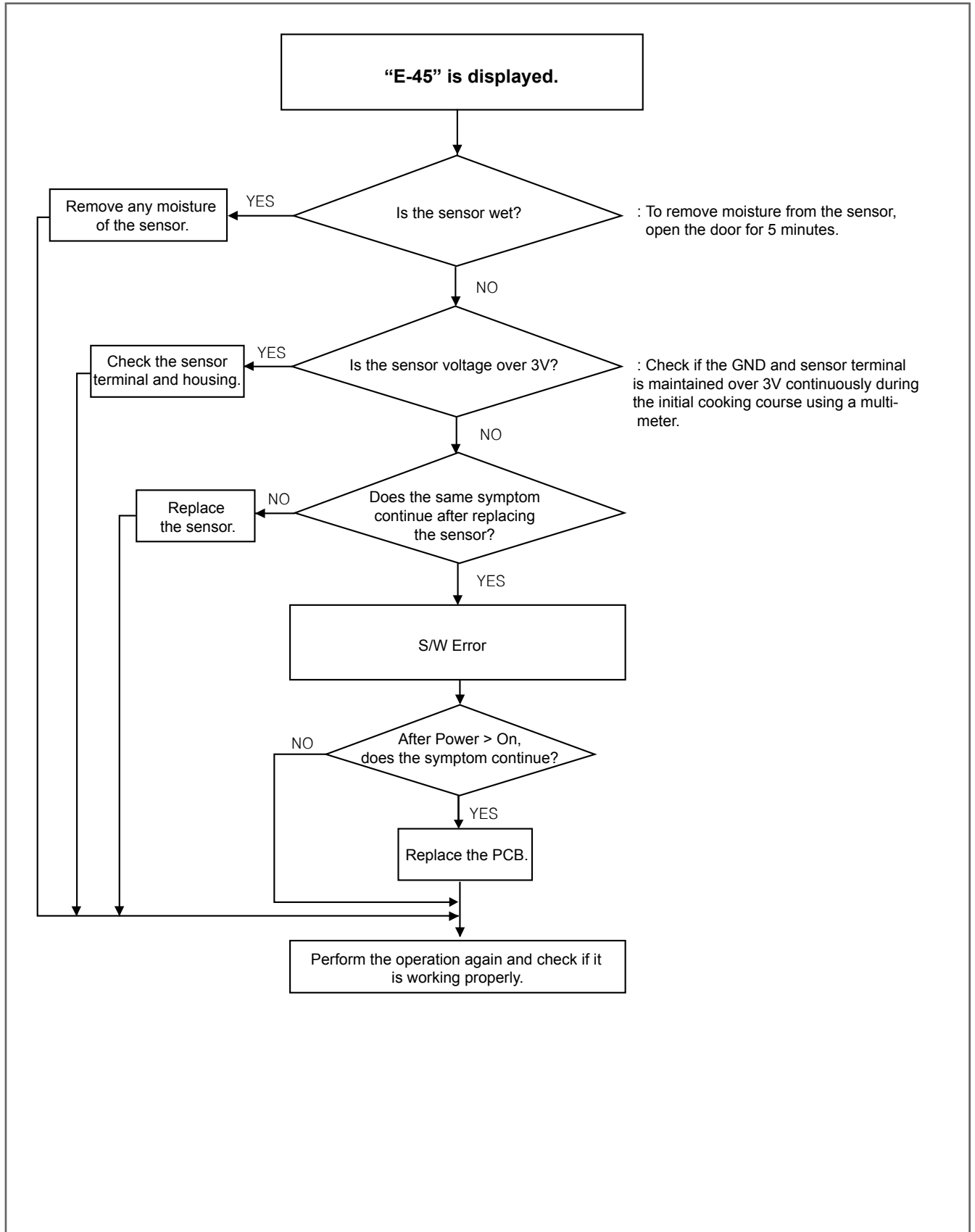

4. Troubleshooting

4-3-8 EEPROM Error

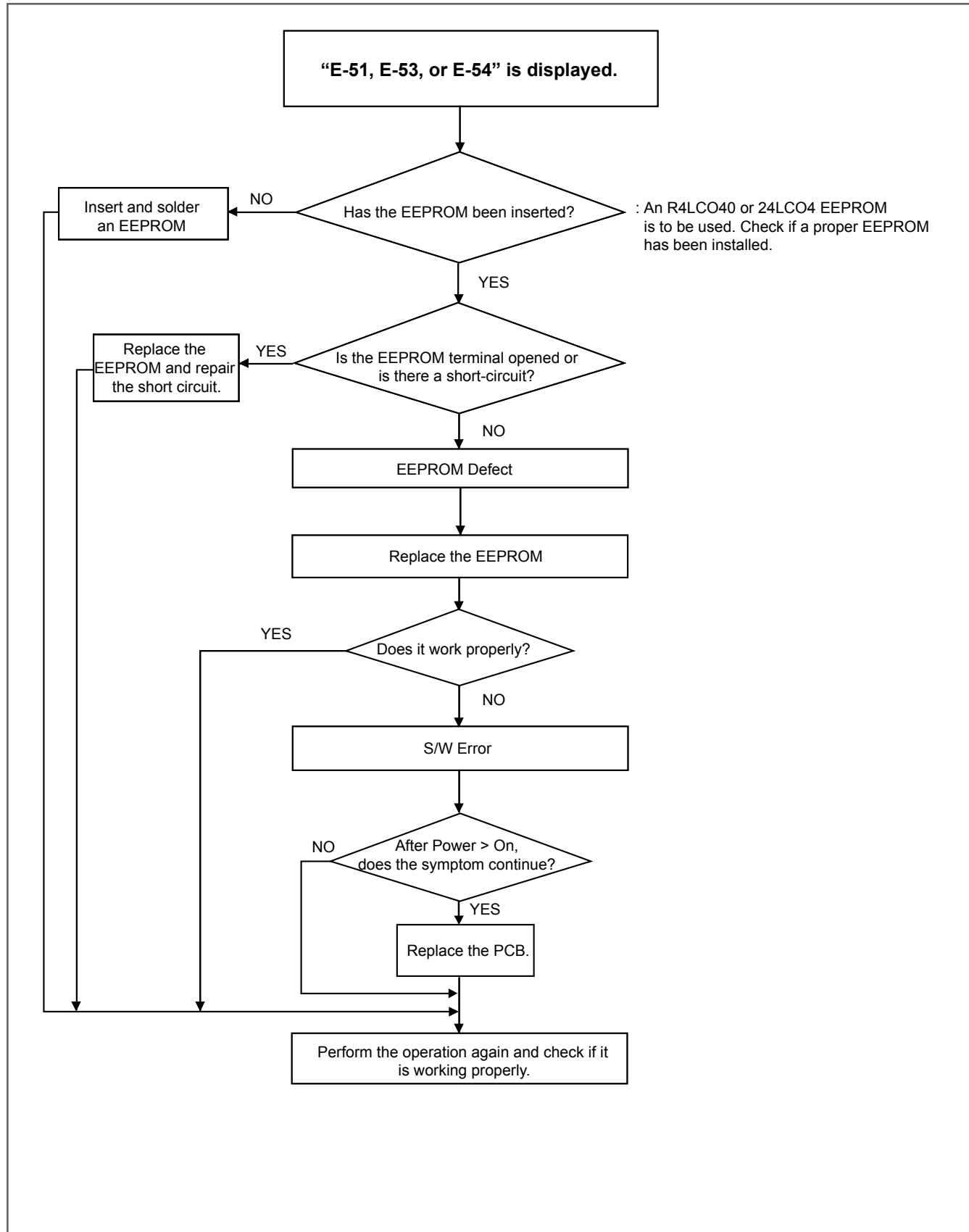

4. Troubleshooting

4-3-9 Preheating Error

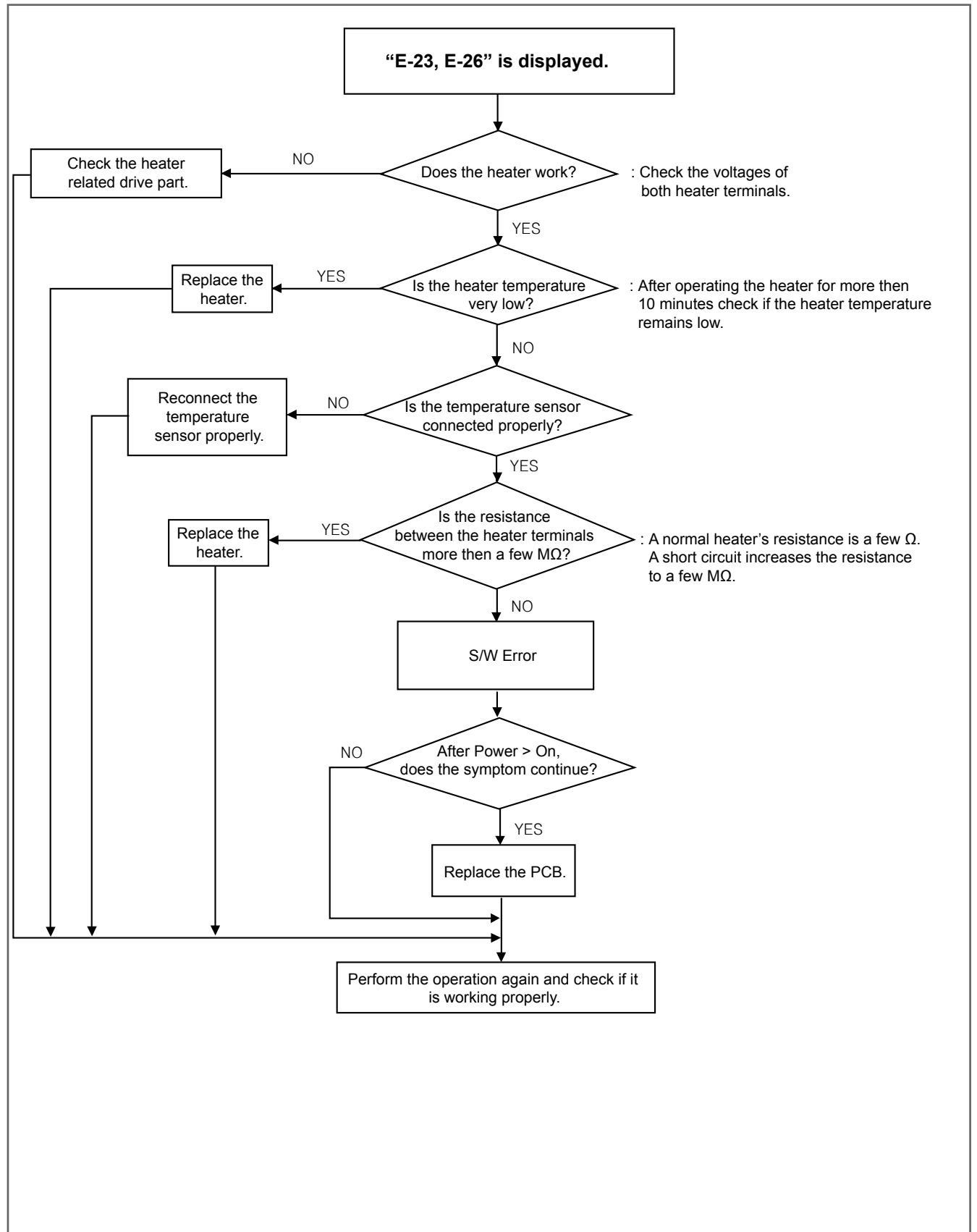

4. Troubleshooting

4-3-10 Cooking Time Over Selection Error

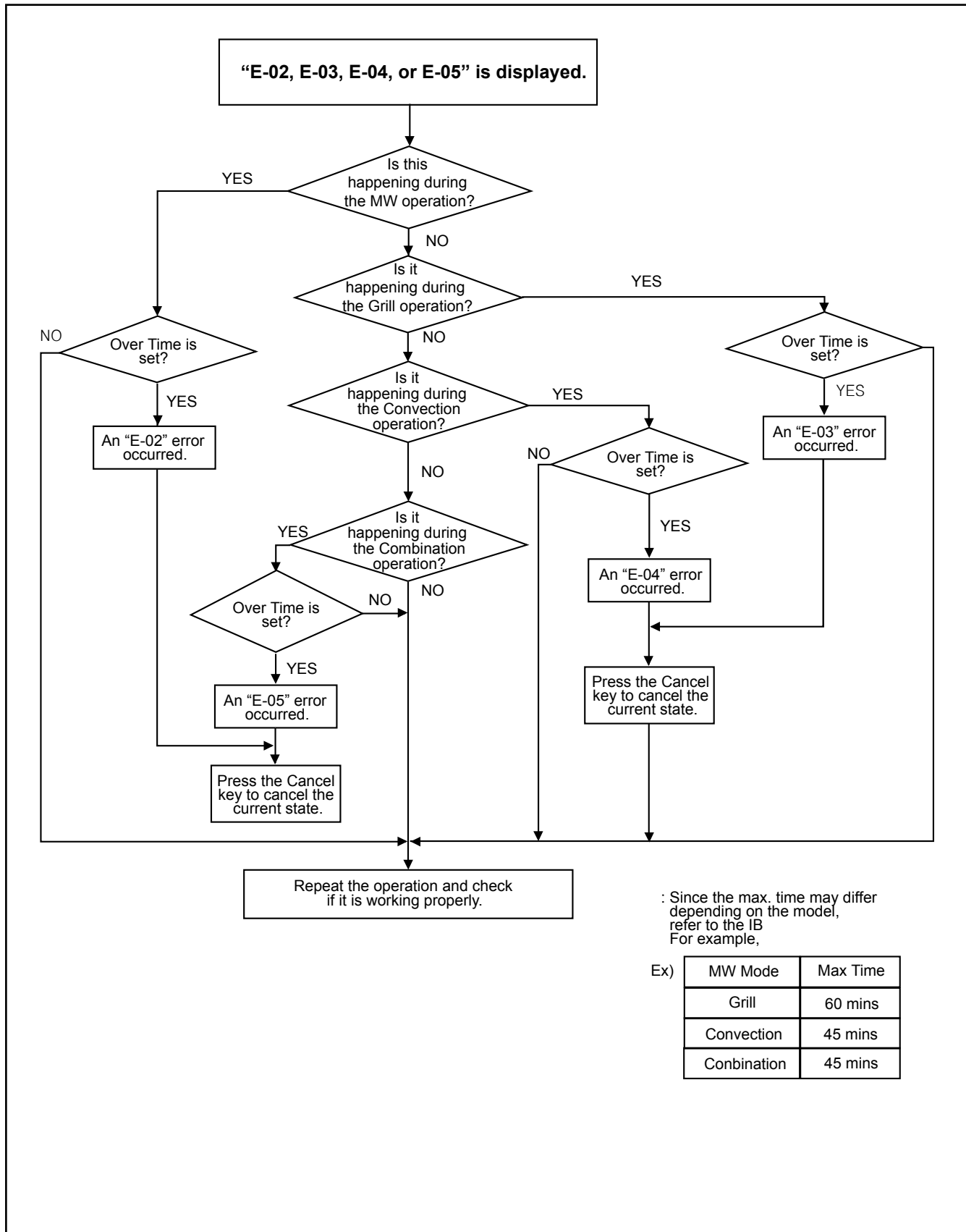

: Since the max. time may differ depending on the model, refer to the IB
For example,

Ex)

MW Mode	Max Time
Grill	60 mins
Convection	45 mins
Combination	45 mins

4. Troubleshooting

4-3-11 Internal Oven Temperature Abnormal Error

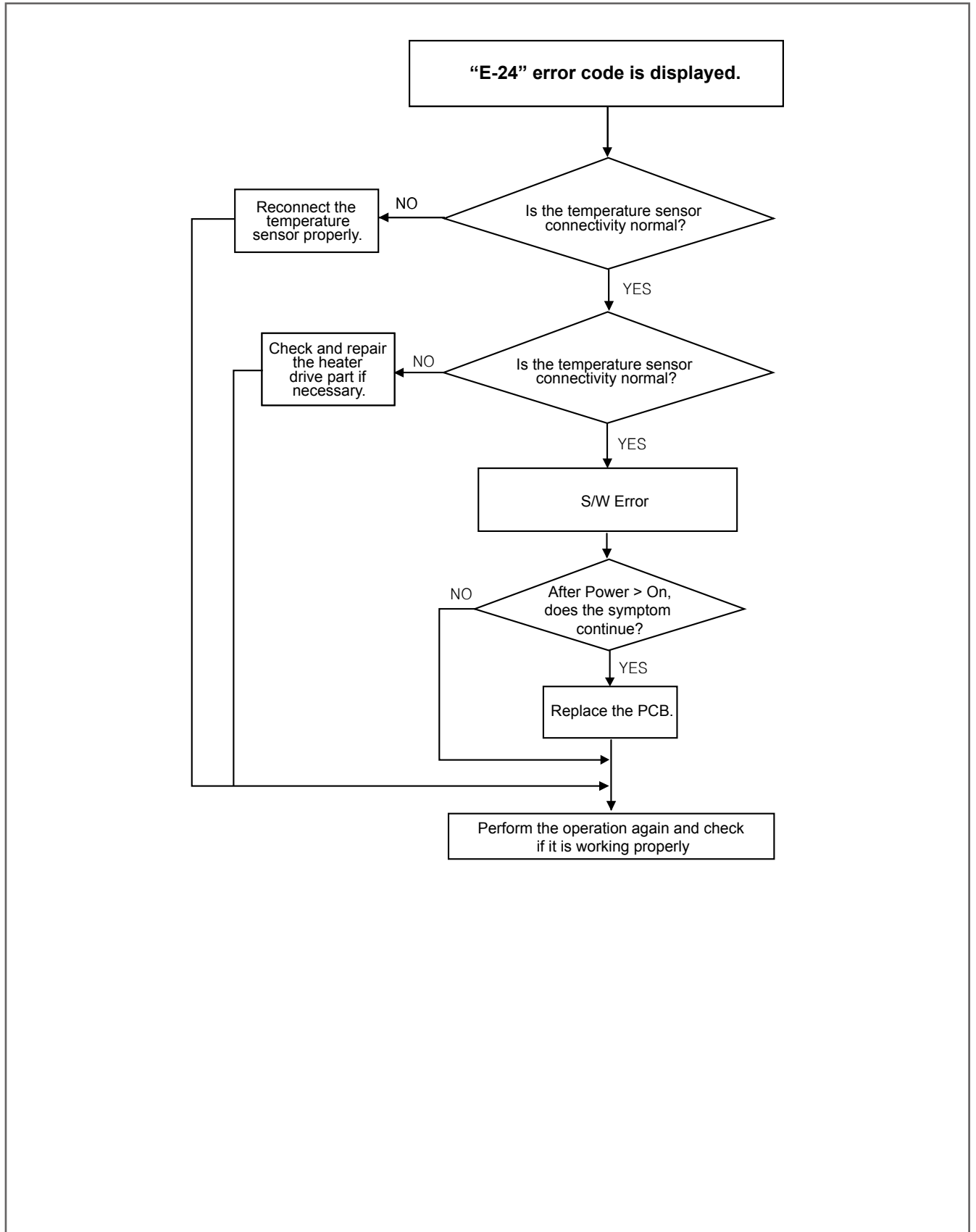

4. Troubleshooting

4-3-12 Swing Heater Detection Error

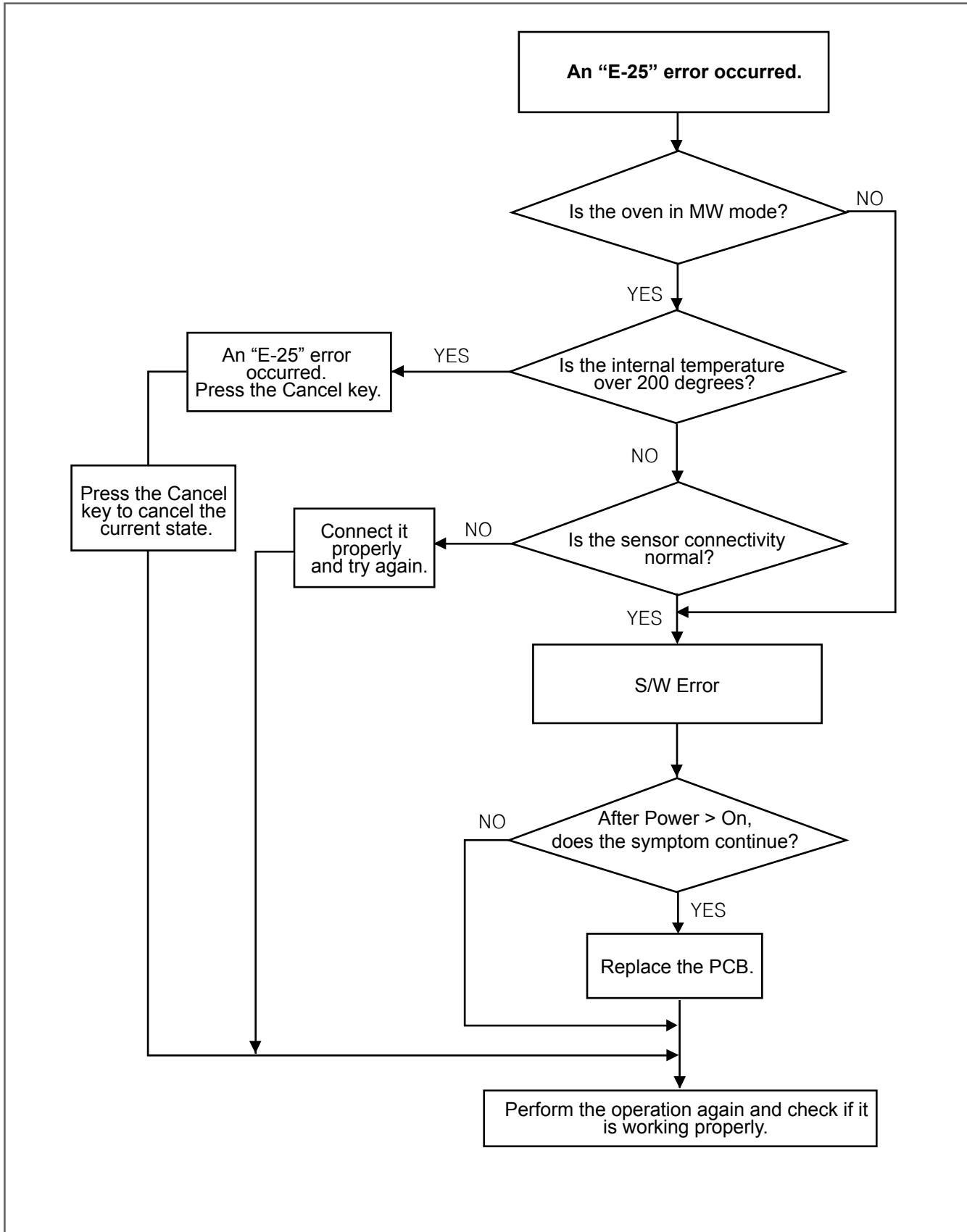

4. Troubleshooting

4-3-13 Swing Heater Detection Error

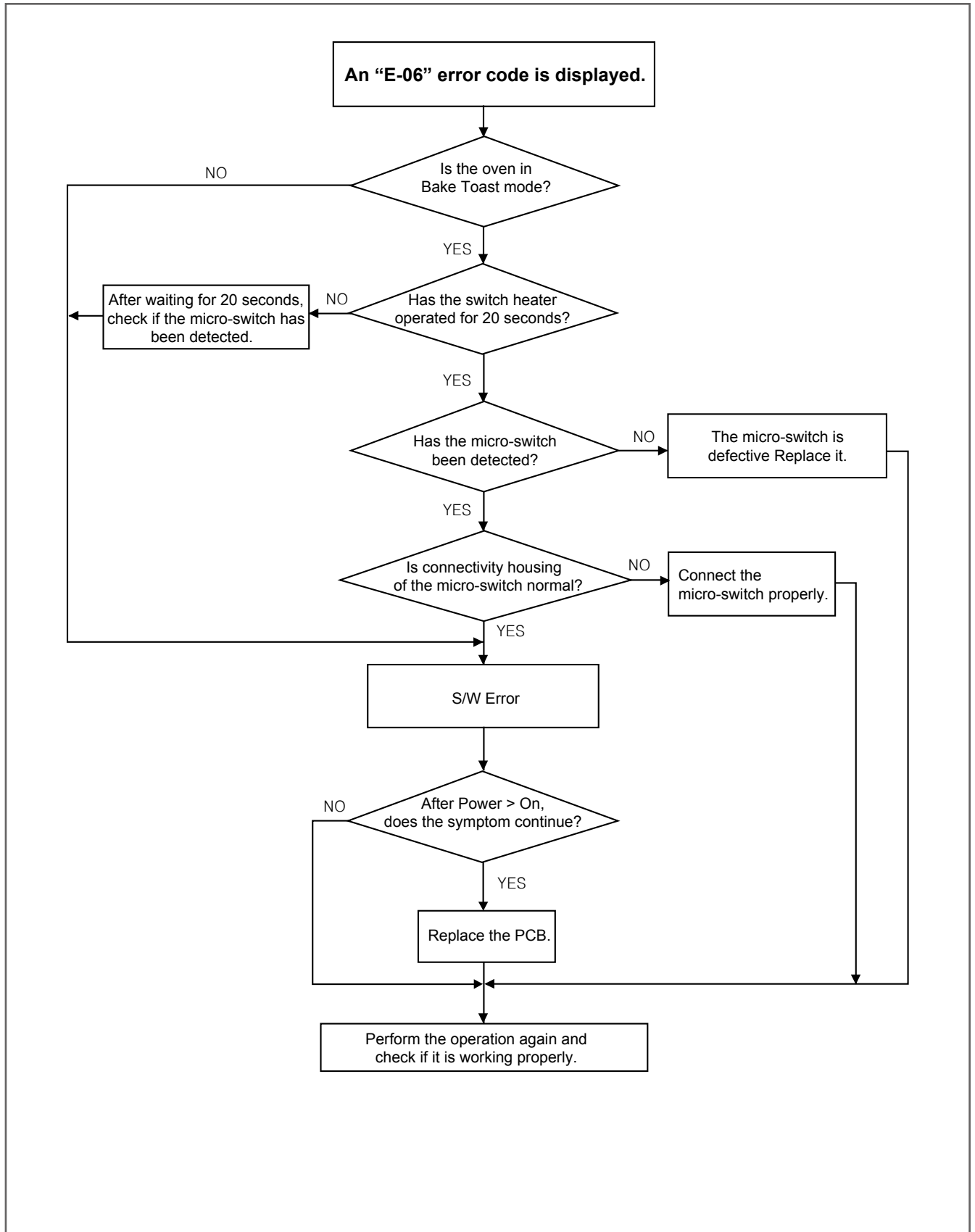

4. Troubleshooting

4-3-14 If oven malfunction

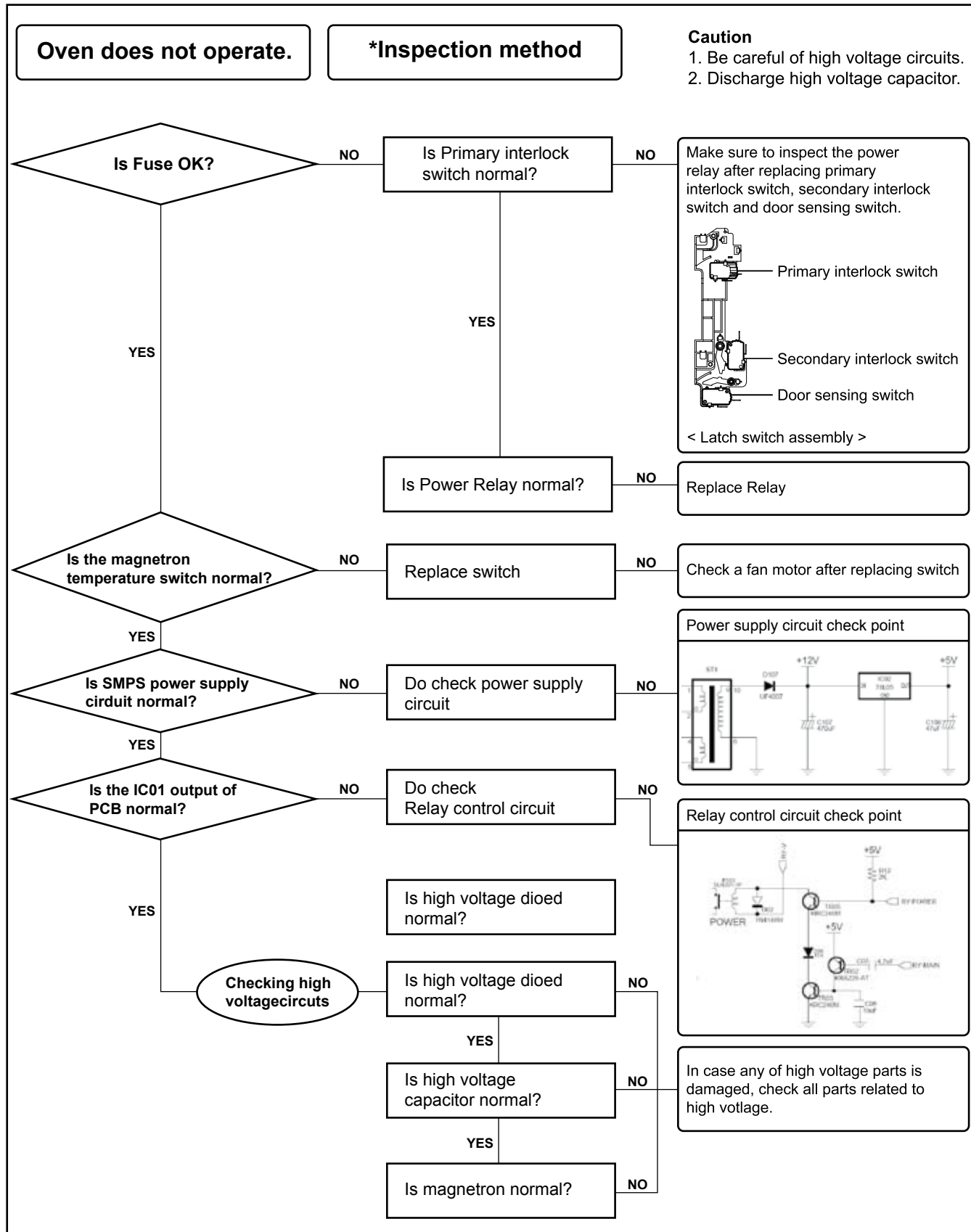

4. Troubleshooting

4-3-15 If button malfunction

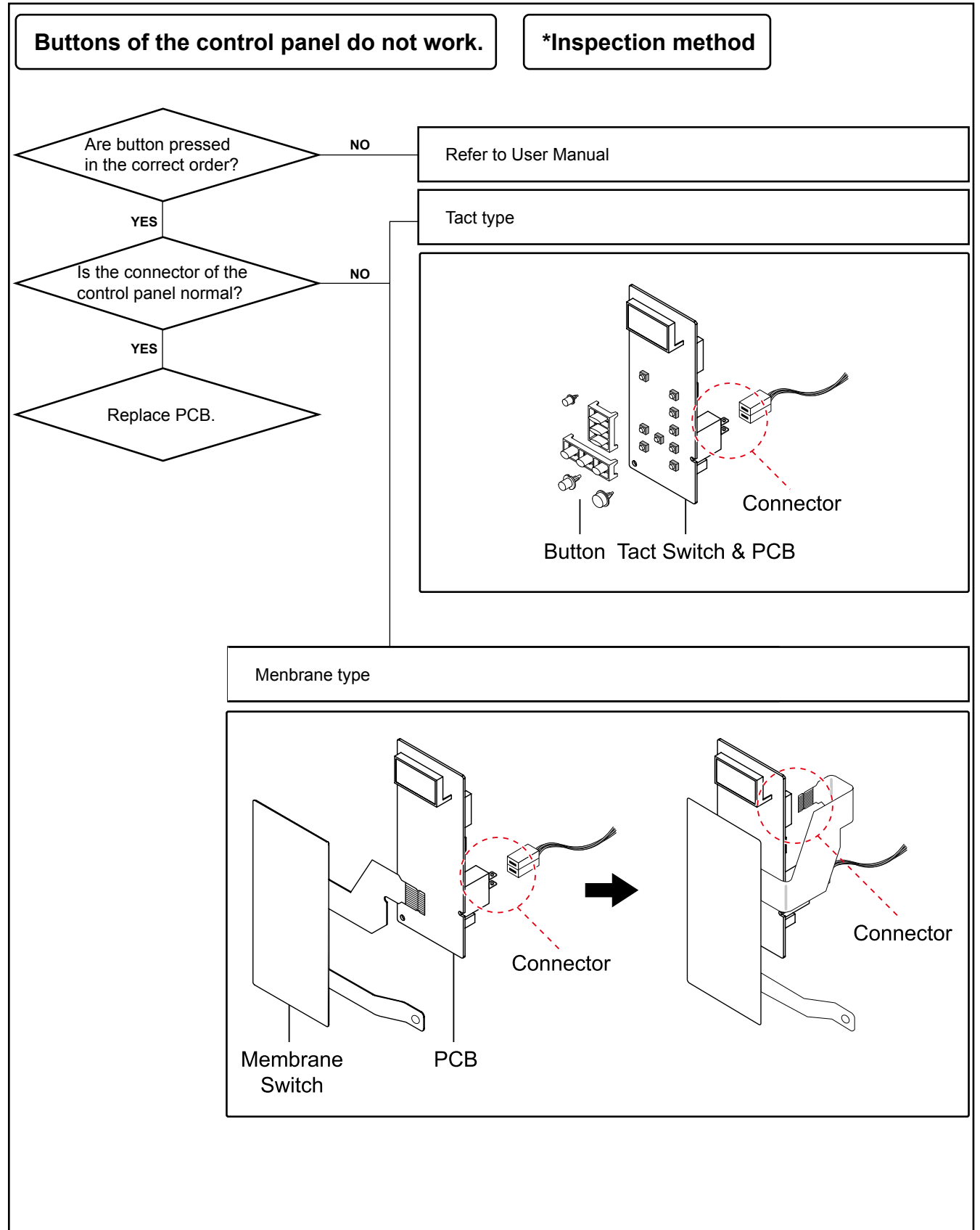

4. Troubleshooting

4-3-16 If food is not heated even though an oven works

Food is not heated even though an oven works.

*Inspection method

Is the latch switch operating normally?

NO

Method to control latch switch

YES

Checking high voltage circuits

Refer to "Checking high voltage circuits" on the previous page.

*Door open

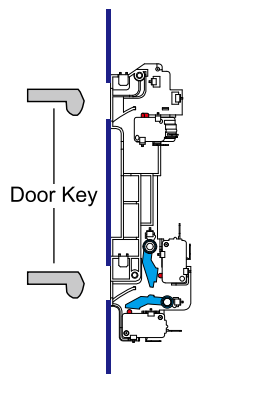

*Door closed

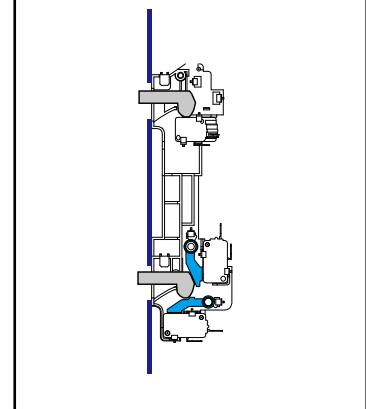

Method to control latch switch

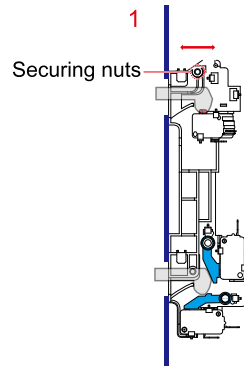

1. Loosely tighten the nuts to check whether the primary interlock switch works by slightly moving latches to right and left. Then firmly tighten nuts.

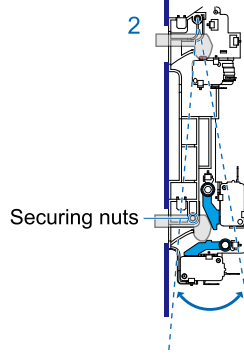

2. Loosely tighten the nuts to check whether the secondary interlock switch and door sensing switch works by slightly moving latches to right and left. Then firmly tighten nuts.

5-1 Exploded Views

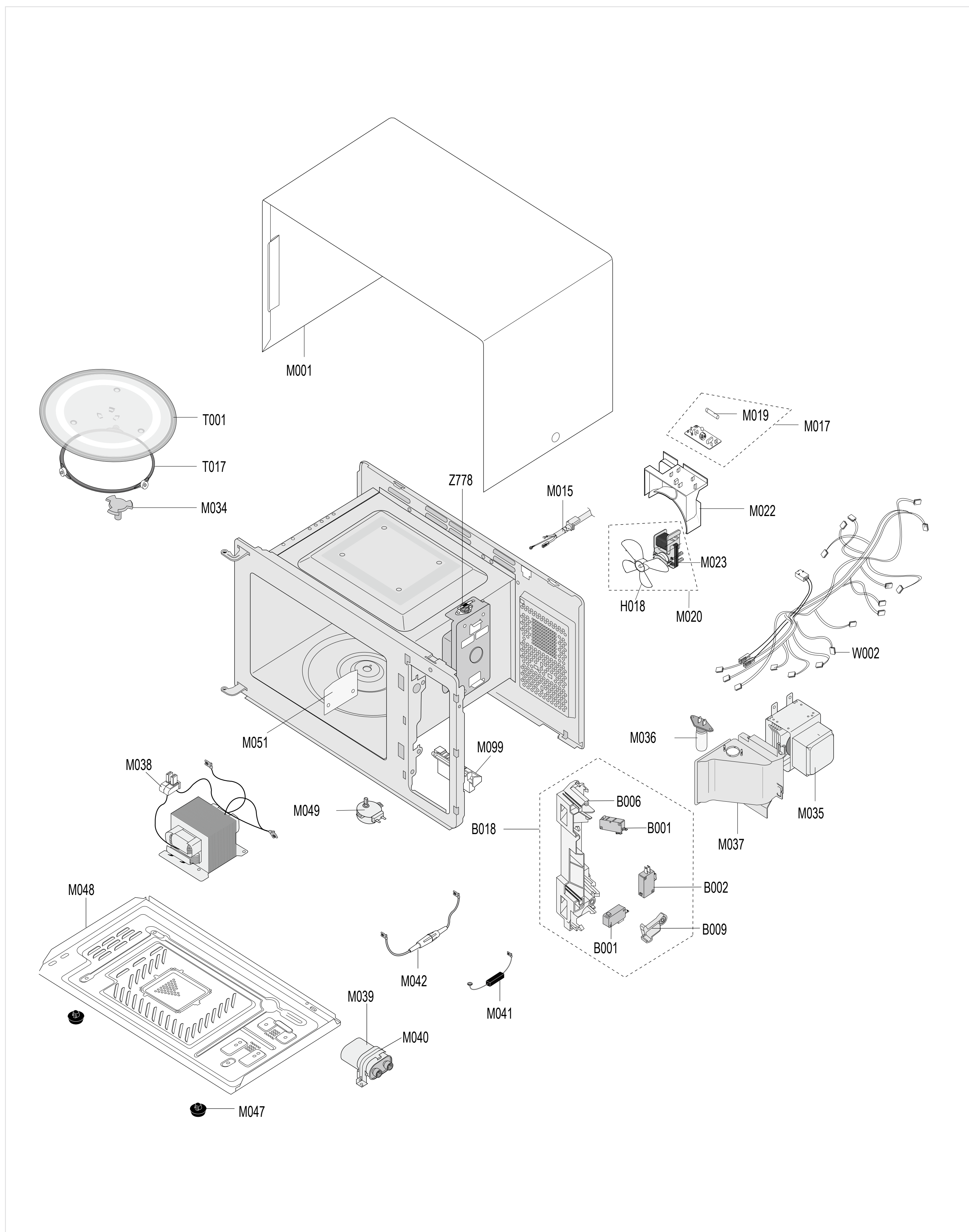

5. Exploded Views and Parts List

5-2 Main Parts List

(S.N.A : SERVICE NOT AVAILABLE)

Level	No.	Code No.	Description	Specification	Q'ty	SA/ SNA	Remark
1-1	M041	0402-001554	HVDIODE-RECTIFIER	HV03-12T01,12000V,0.4A	1	SA	-
1-1	M039	2501-001016	C-OIL	950nF,2.1KV,BK,35x54x80,20mm	1	SA	-
1-1	M036	4713-001046	LAMP-INCANDESCENT	240V,104mA,25W,ORG,-,-	1	SA	-
1-1	M038	DE26-00099A	TRANS H.V	SHV-EURO1-1,230V,50HZ,2330V,3.	1	SA	-
1-1	M049	DE31-10154A	MOTOR SYNCHRONOUS	M2HJ49ZR02,ST-16,50/60	1	SA	-
1-1	Z778	DE47-20008A	THERMOSTAT	PW2N-52JC,100/60,250V/7.5A,H,	1	SA	-
1-1	M040	DE61-00139A	BRACKET-HVC	NC2000,SECC,T0.8,-,-,0.6/0	1	SA	-
1-1	M047	DE61-40066A	FOOT	-,PP,-,BLK,-,-,-	1	SA	-
1-1	M001	DE64-00350K	PANEL-OUTER	MGB 22 C/STEEL,T0.5GE-WHT	1	SA	-
1-1	M099	DE66-90113A	LEVER-DOOR	PP(TB53-GH41),T2.5,-,-,12g,NT	1	SA	-
1-1	M034	DE67-00140A	COUPLER	PPS,(ESS840),3G,BRN,NEW	1	SA	-
1-1	M022	DE71-00148A	COVER-BLOWER	PP,T1.5NTR MW850WA NC2000	1	SA	-
1-1	M051	DE71-00151A	COVER MGT	PP,T2,W54,L129,GE-WHTMW850WA	1	SA	-
1-1	M037	DE71-60457C	COVER-AIR	3RD-0.7(BTM),PP(FB53 G30),-,-,	1	SA	-
1-1	T001	DE74-00027A	TRAY-COOKING	GLASS,T5,-,NC2000	1	SA	-
1-1	M048	DE80-00023A	BASE PLATE	SGCC T0.6 MW850WA NC2000	1	SA	-
1-1	M042	DE91-70061J	ASSY-H.V.FUSE	THV060T-0650-H,5KV0.65A,WL	1	SA	-
1-1	M017	DE96-00010C	ASSY NOISE FILTER	SN-3WED(12),250V12A,EU	1	SA	-
1-2	M019	3601-001019	FUSE-CARTRIDGE	250V,12A,SLOW-BLOW,CERAMI	1	SA	-
1-1	M020	DE96-00031A	ASSY-MOTOR FAN	SMF-3RDEA,230V50HZ,2400RP	1	SA	-
1-2	M023	DE31-10184A	MOTOR-FAN	SMF-3RDEA,230V50Hz,2400rpm,3rd	1	SA	-
1-2	H018	DE31-90057A	BLADE-FAN	PP,T1.5,-,-,3RD-W,-,-,-	1	SA	-
1-1	B018	DE96-00115C	ASSY BODY LATCH	CE2611N,NC2000(BUTTON)	1	SA	-
1-2	B002	3405-001032	SWITCH-MICRO	125/250VAC,16A,200GF,SPDT	1	SA	-
1-2	B001	3405-001034	SWITCH-MICRO	125/250VAC,16A,200GF,SPST-N	2	SA	PRI,SEC
1-2	B009	DE66-00088A	LEVER-SWITCH	NC2000(0.6/0.8/1.2),PP,-,-,	1	SA	-
1-2	B006	DE72-00138B	BODY-LATCH	NC2000(0.6/0.8/1.2),PP(FH44N)	1	SA	-
1-1	M015	DE96-00385D	ASSY POWER CORD	CEE,EU,250V/8A,1500MM,30	1	SA	-
1-1	W002	DE96-00407A	ASSY-WIRE HARNESS A	MW87W,CMO	1	SA	-
1-1	T017	DE97-00193B	ASSY-GUIDE ROLLER	NC2000 0.6,T2*P1198(14	1	SA	-
1-1	M035	OM75S(31)ESGN	ASSY-MGT		1	SA	-

5. Exploded Views and Parts List

5-3 Door Parts List

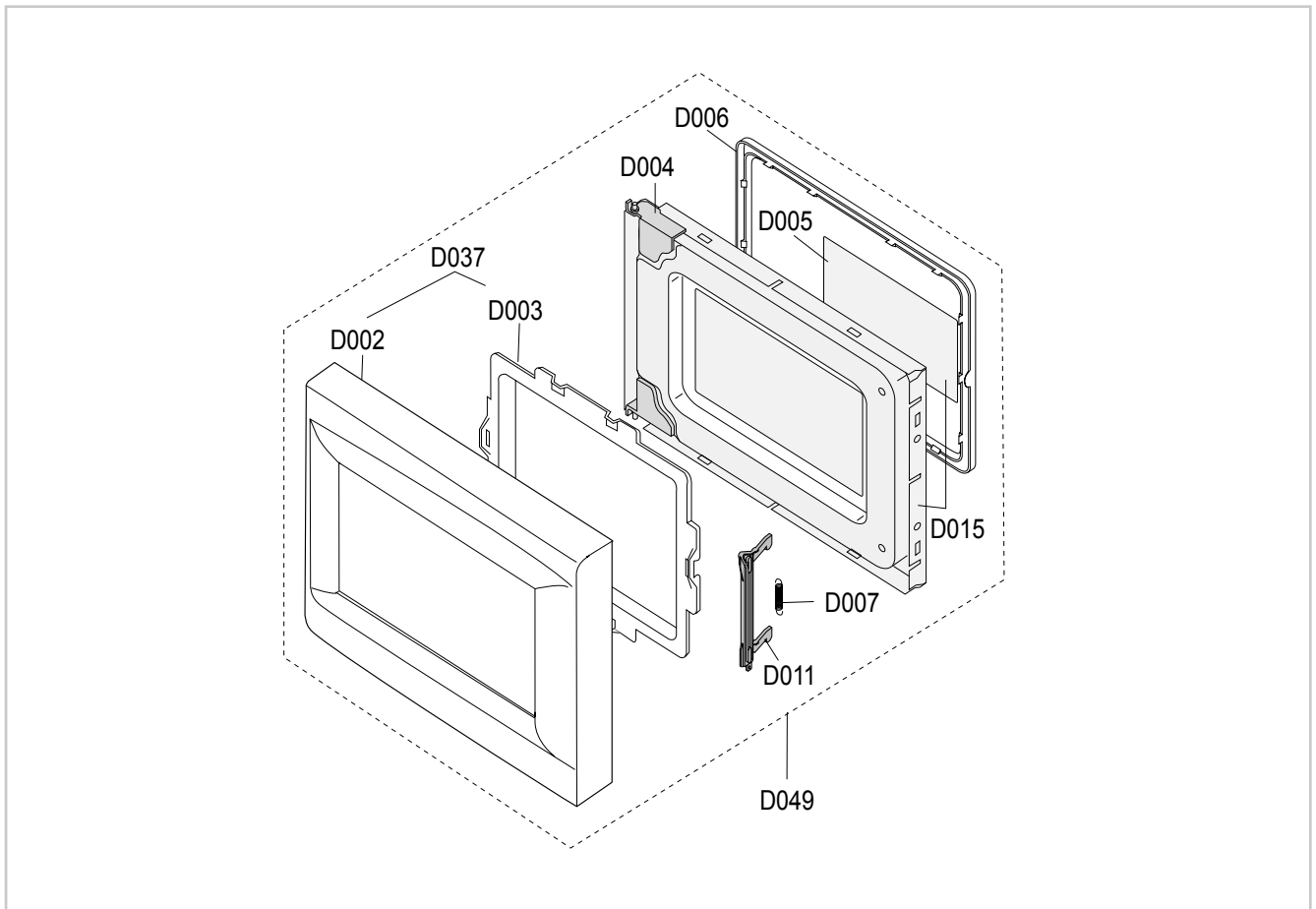

(S.N.A : SERVICE NOT AVAILABLE)

Level	No.	Code No.	Description	Specification	Q'ty	SA/SNA	Remark
1-1	D049	DE94-00256J	ASSY DOOR	M1618/1638,GE/WHT	1	SA	-
1-2	D007	DE61-00198A	SPRING KEY	M1877,HSWR D6,23 1/4 T0.7	1	SA	-
1-2	D011	DE64-40006F	DOOR-KEY	POM(F20-02),-,-,12G,BLK,MW7897	1	SA	-
1-2	D006	DE64-40008B	DOOR-C	-,-,PP,CE745G,-,-,-,BLK,-	1	SA	-
1-2	D037	DE94-00253J	ASSY DOOR-A	M1618,M1638/XEG,XET,PURE-WHT	1	SA	-
1-3	D002	DE64-00091J	DOOR-A	M1618/XEG,XET,ABS,-,-,GE-WHT,-,-	1	SA	-
1-3	D003	DE67-20186A	SCREEN-DOOR	SAN,T2.2,W354,L224,SMOG,3RD-	1	SA	-
1-2	D015	DE94-00124B	ASSY DOOR SUB	MW4593G,BLK,3RD-0.7,-,-	1	SA	-
1-3	D005	DE01-00112A	FILM-DOOR	-,-,PET,-,L268,T0.15,W150,NTR,-,-	1	SA	-
1-3	D004	DE92-50133C	ASSY DOOR-E	MW4593G,-,-,BLK,3RD-0.7,-,-,-	1	SA	-

5. Exploded Views and Parts List

5-4 Control Parts List

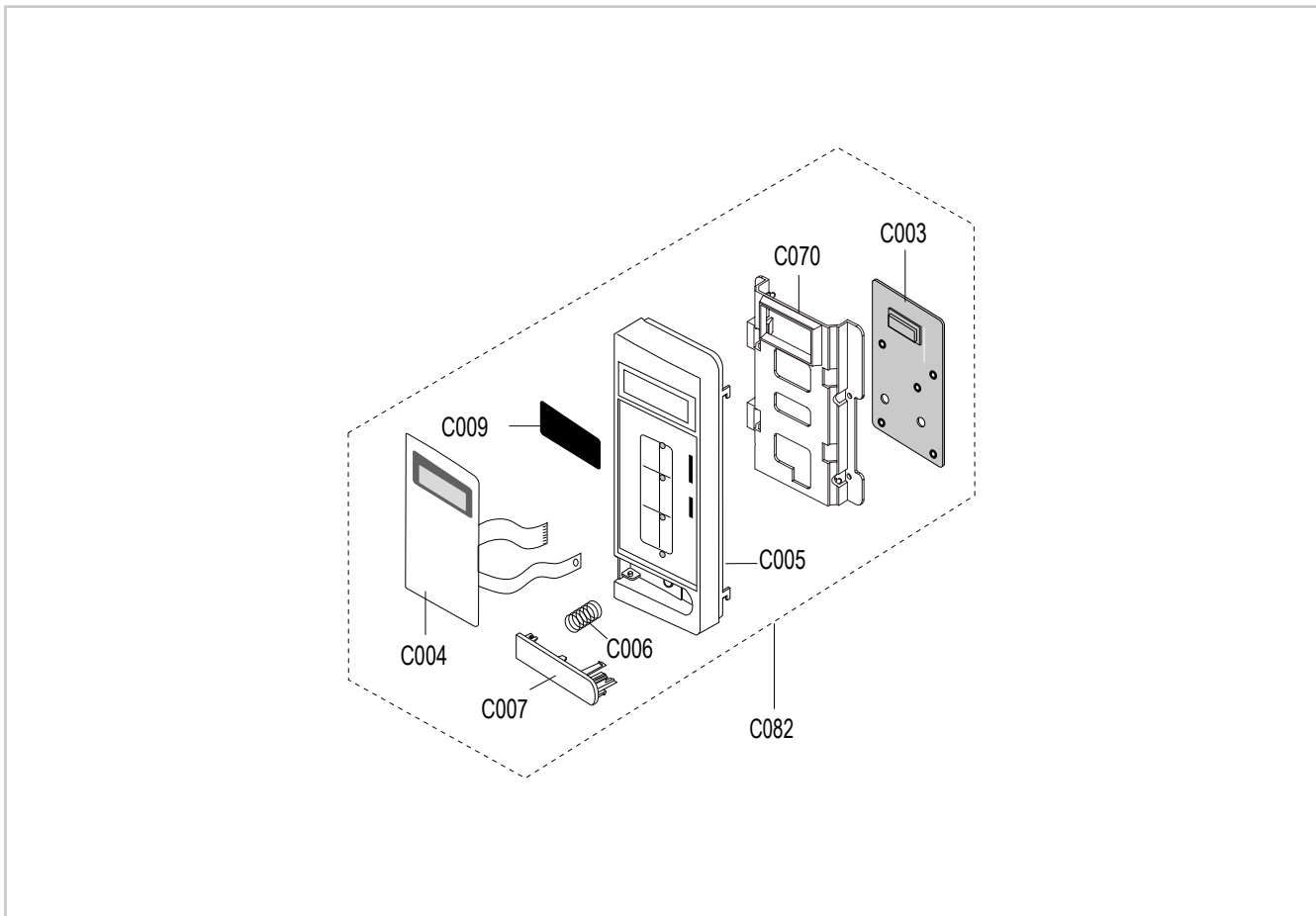

(S.N.A : SERVICE NOT AVAILABLE)

Level	No.	Code No.	Description	Specification	Q'ty	SA/SNA	Remark
1-1	C082	DE94-00979J	ASSY-CONTROL BOX	230V50HZ,MW73VR/BWT,GE-	1	SNA	-
1-2	C004	DE34-00193G	SWITCH MEMBRANE	MW73VR/BWT,-,PET,-,230	1	SA	-
1-2	C070	DE61-00665A	HOLDER-LED	ALL-0.8,PP,-,-,BLACK,LED-BA	1	SA	-
1-2	C006	DE61-70076A	SPRING-BUTTON	-,HSWR,PI0.6,PI0.6,-,-,-	1	SA	-
1-2	C007	DE66-20275B	BUTTON-PUSH	JES831WB,-,-,-,-	1	SA	-
1-2	C009	DE67-40179A	WINDOW-DISPLAY	SAN,T2.0,-,-,SMOG,-,3RD-W	1	SA	-
1-2	C005	DE72-70201J	CONTROL-PANEL	JE735WZC,ABS(VE0855),-,-,-	1	SA	-
1-2	C003	RCS-SM3L-96	ASSY PCB PARTS	MW73VR/BWT,SMPS,230V/50HZ	1	SA	-

5. Exploded Views and Parts List

5-5 Standard Parts List

(S.N.A : SERVICE NOT AVAILABLE)

Level	Code No.	Description	Specification	Q'ty	SA/ SNA	Remark
1-1	6002-001250	SCREW-TAPPING	TH,+,2,M4,L8,Tin-Ni,SWRC18	1	SNA	O/PANEL
1-1	6006-001170	SCREW-ASSY TAPP	WS,TH,+,M4,L10,ZPC(YEL)	3	SA	PCB EARTH,P/C EARTH,NOISE FILTER EARTH
1-1	6006-001176	SCREW-ASSY TAPT	WT,PH,+,M4,L8,ZPC(YEL)	1	SNA	BKT HVC & DIODE
1-1	DE60-10051A	SCREW-TAP PH	-, -,MSWR,-,PH,M4,-,L6,-,-	1	SA	DRIVE MOTOR
1-1	DE60-10080A	SCREW-WASHER	-, -, -,M5,L12,-,2S,-,-	2	SA	HVT,MGT
1-1	DE60-10082I	SCREW-A	-, -, -,2S-4X10,FEFZY,-, -, -, -	7	SA	C/BLOWER,B/PLATE,B/LATCH,AIR/ COVER,PANEL
1-1	DE60-30016A	NUT-FLANGE	M4,MSWR10,-, -, -, -, -	1	SA	F-MOTOR
1-2	6002-000630	SCREW-TAPPING	PH,+,2S,M3,L8,ZPC(YEL),SWR	2	SA	HOLDER PCB,PCB

6-1 PCB Diagrams

(This Document can not be used without Samsung's authorization)

No.	Parts Number	Part Name	Function and Rule
1	RY01	Main Relay	Power Supply Relay
2	RY02	Inrush Relay	Inrush Electric Current Decrease Device
3	RY03	Power Relay	MWO Control Relay
4	RY04	Grill Heater Relay	MWO Grill Heater Control Relay
5	RY05	T/T Relay	T/T control Relay
6	CN01	A Terminal for Connecting with LVT	A Terminal for Connecting with LVT and SMPS Power Supply
7	CN02	A Terminal for Connecting with Relay	A Terminal for Connecting with Relay and SMPS Power Supply
8	CN03	A Terminal for Connecting with Connector	A Terminal for Connecting with Connector and SMPS Power Supply
9	CN04	A Terminal for Connecting with T/T LAMP	A Terminal for Connecting with T/T Lamp and SMPS Power Supply
10	CN05	A Terminal for Connecting with Humidity Sensor	A Terminal for Connecting with Humidity Sensor and SMPS Power Supply

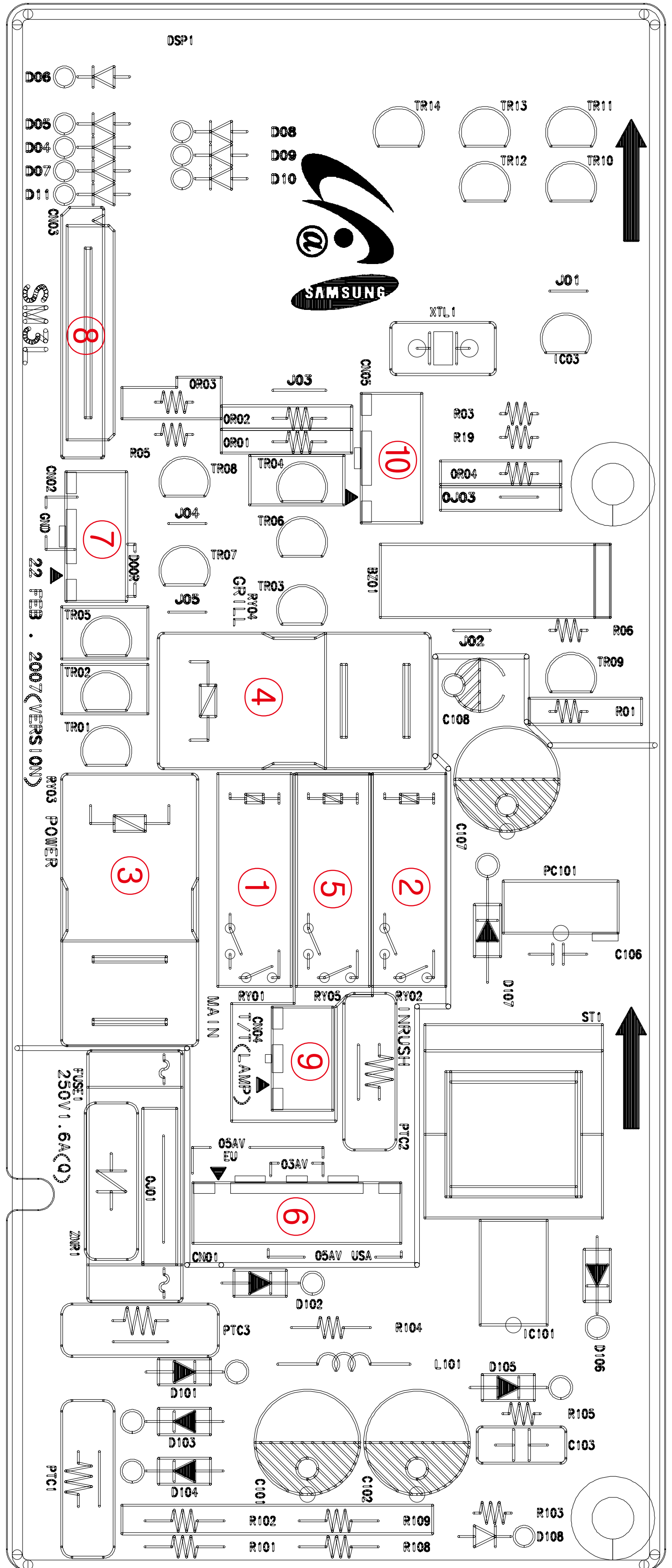

7-1 Wiring Diagrams

(This Document can not be used without Samsung's authorization)

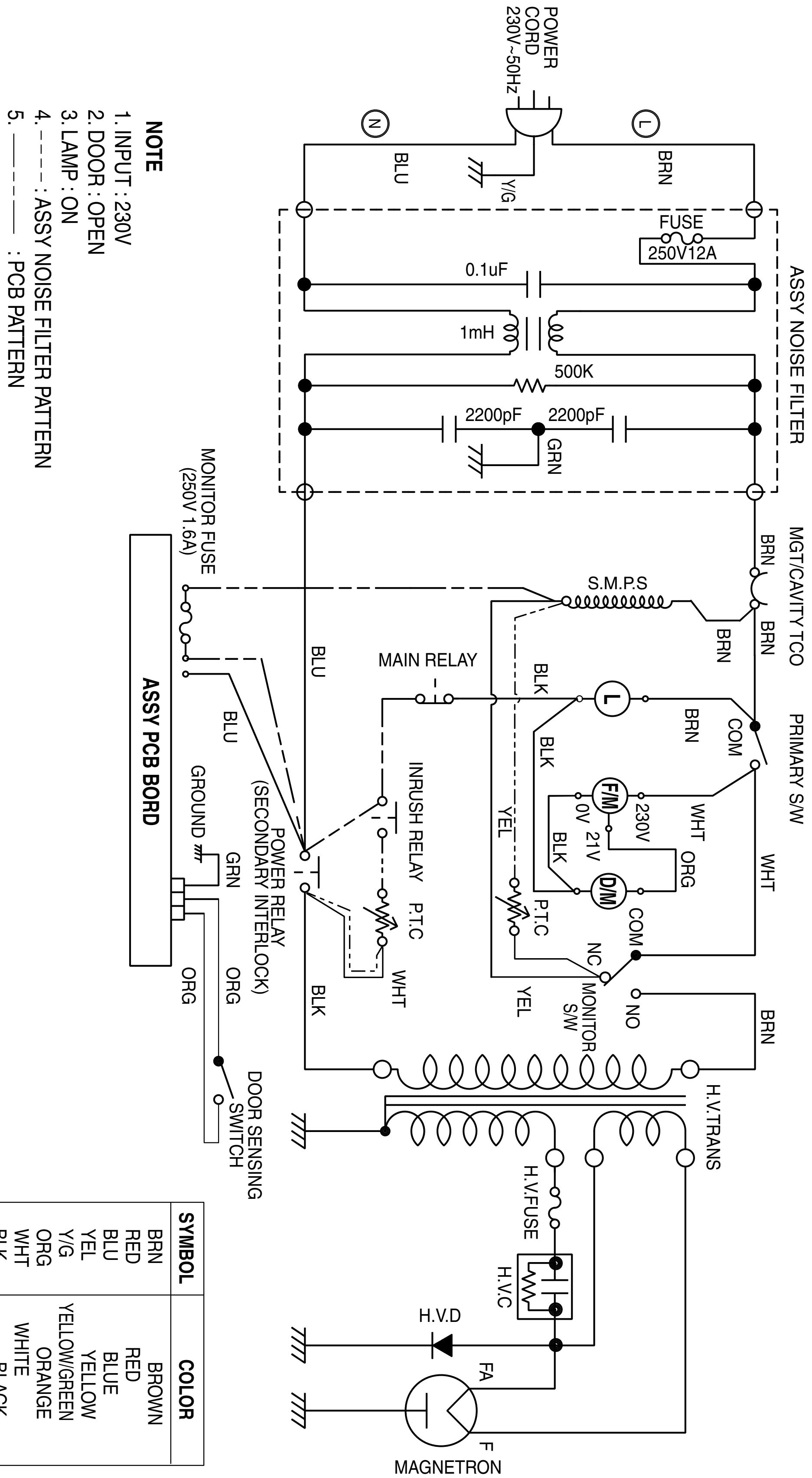

7-1 Wiring Diagrams

(This Document can not be used without Samsung's authorization)

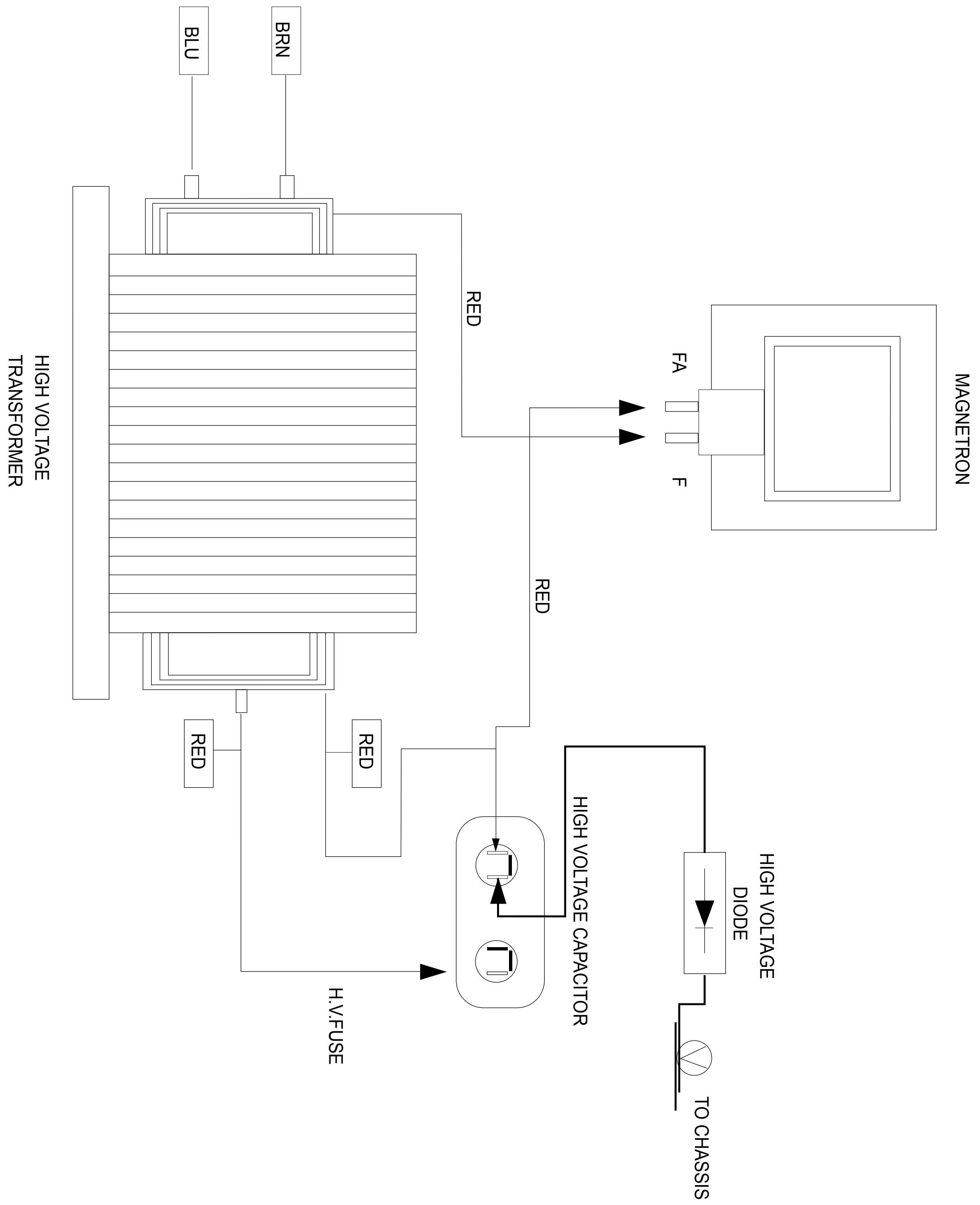

8-1 Schematic Diagrams

(This Document can not be used without Samsung's authorization)

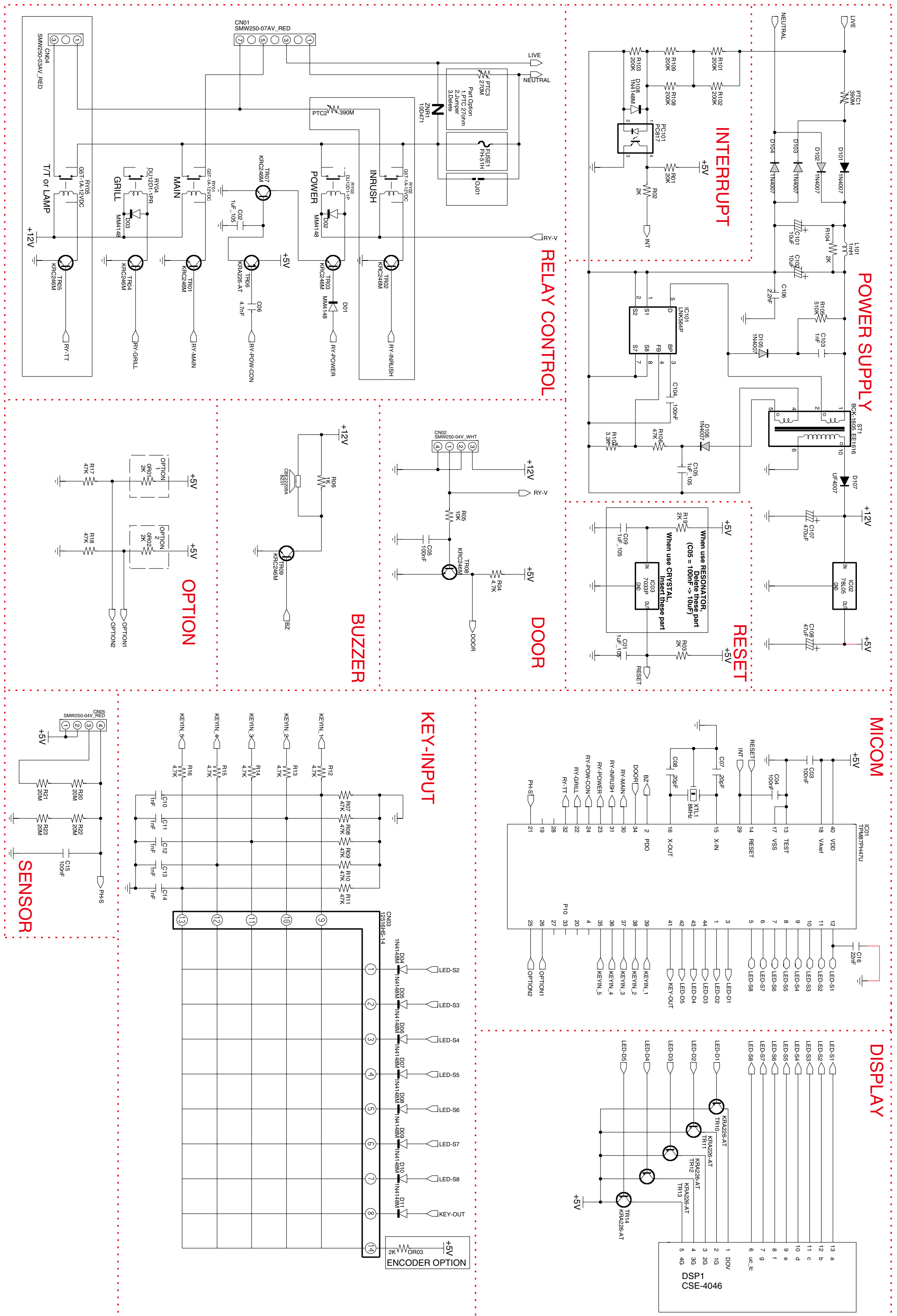



GSPN (Global Service Partner Network)

Contry	Web Site
North America	service.samsungportal.com
Latin America	latin.samsungportal.com
CIS	cis.samsungportal.com
Europe	europe.samsungportal.com
China	china.samsungportal.com
Asia	asia.samsungportal.com
Mideast & Africa	mea.samsungportal.com