

6. Schematic Diagram

6-1. Overall Block Diagram

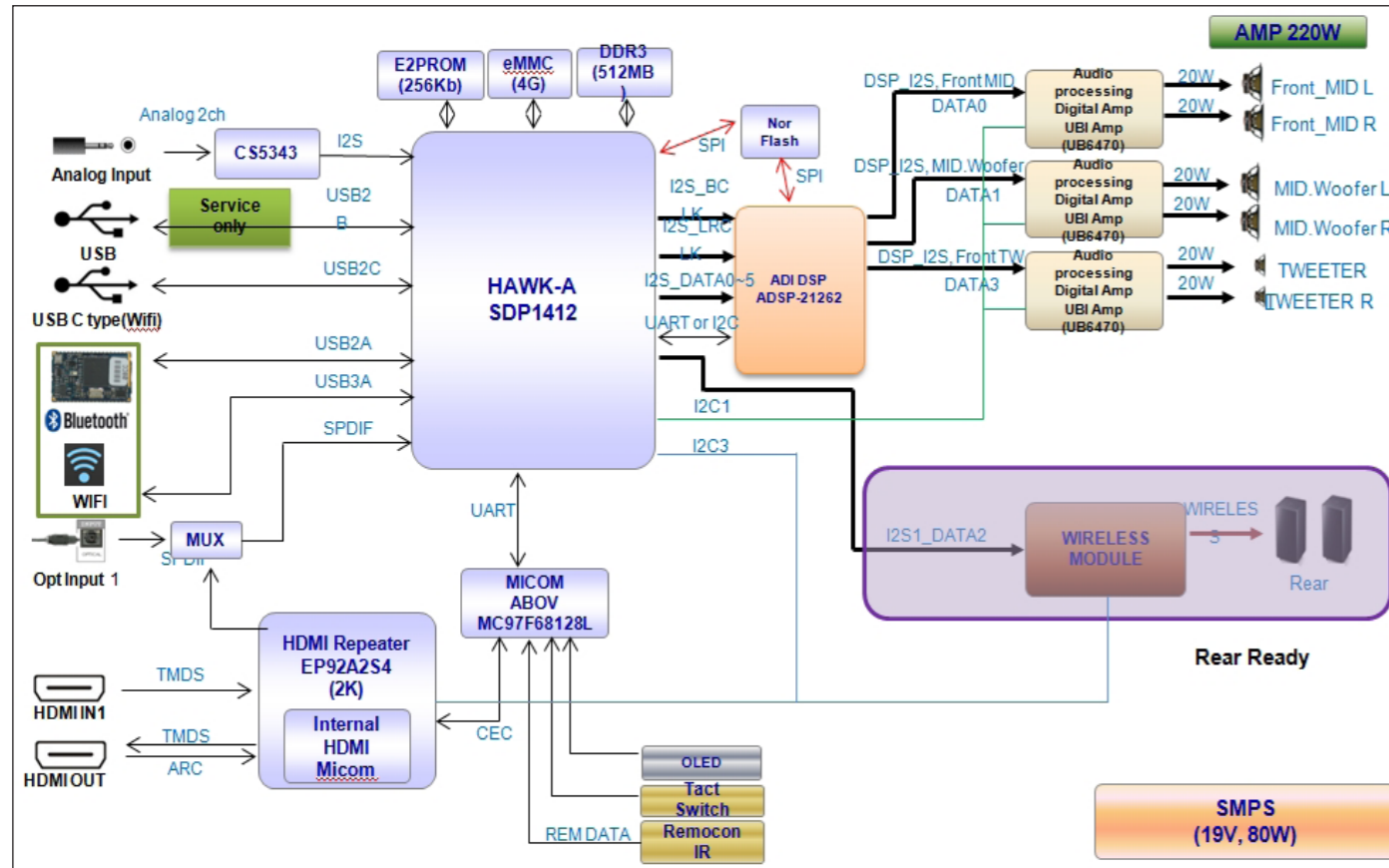

- Main System Digital Signal Processor which is HAWK-A (SDP1412)
- All display is registered by OLED.
- Serial Interface between I2C is operated with various protocol over the whole system.
- DSP(SDP1412) implement DSP AUDIO DECODING function by I2S.
- Power On/Off by Micom port is possible.
- Function and sound field can be controlled by remote controller and keys.
- HDMI repeater IC includes internal HDMI Micom.
- The active subwoofer operate with wireless system and Dongle.

6-2. MAIN-1



POWER DC_DC

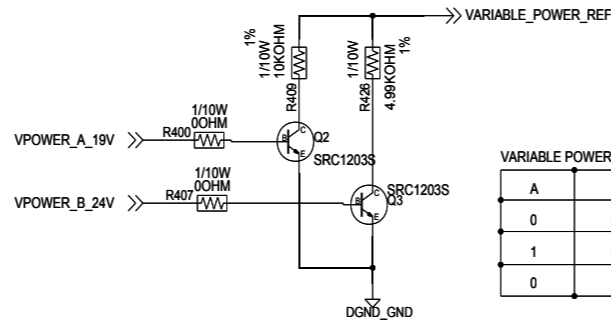
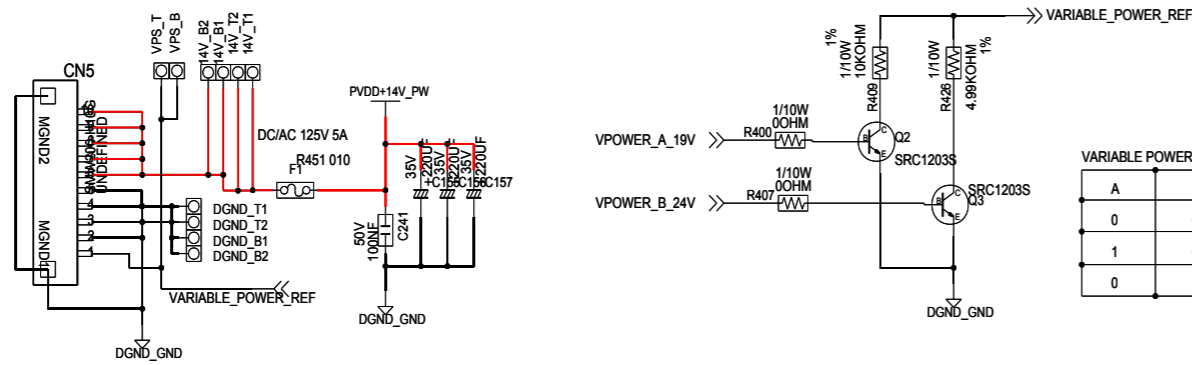

VARIABLE POWER OPTION

A	B	SMPS OUTPUT
0	0	14V
1	0	19V
0	1	24V

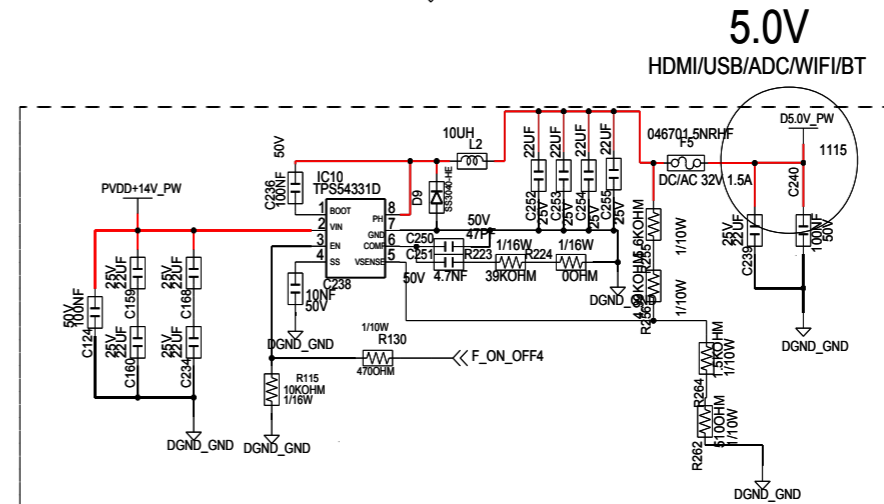
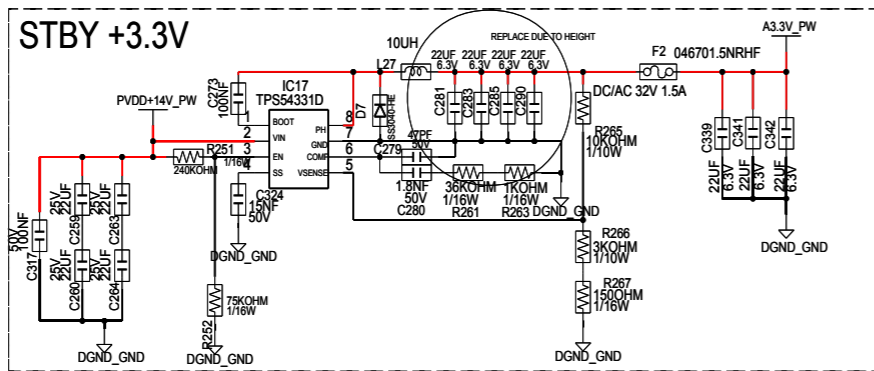
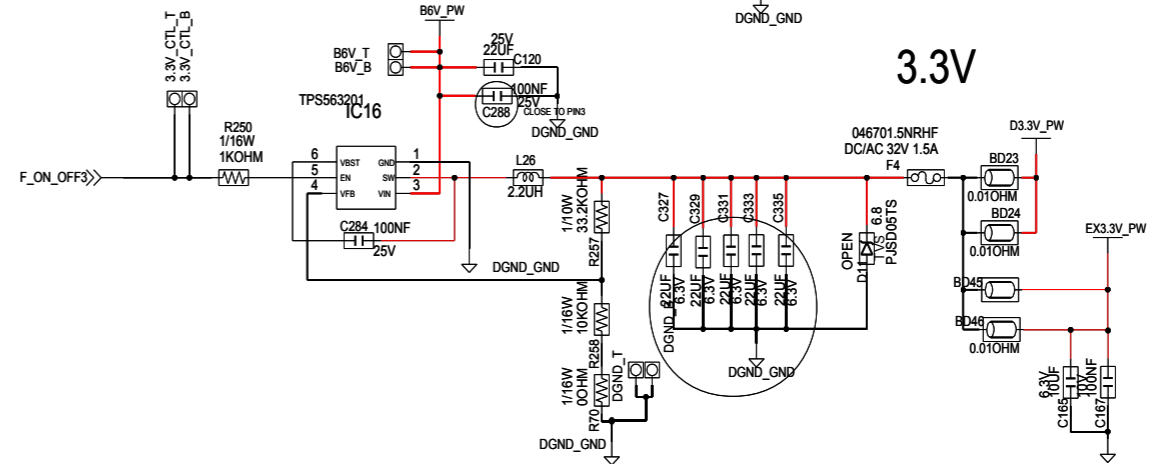
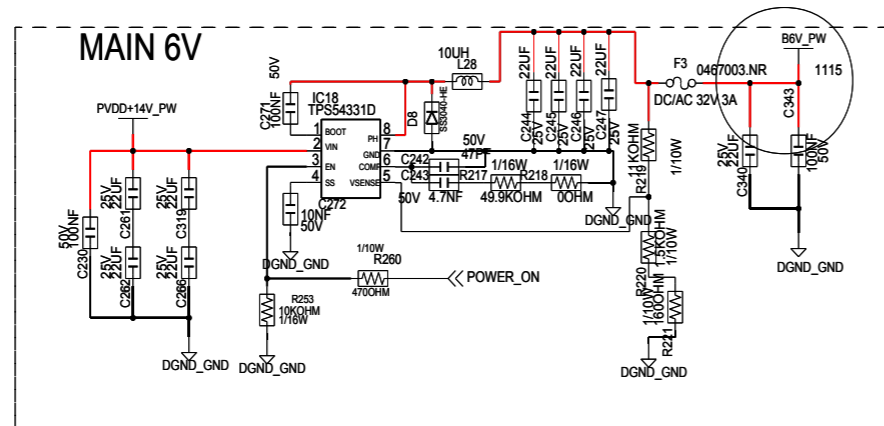
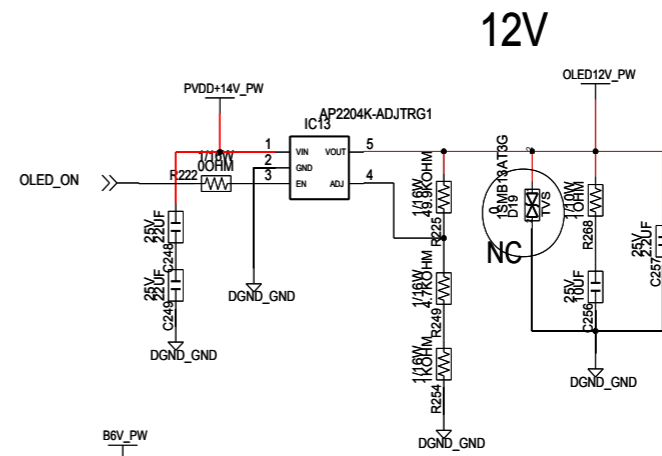

6-3. MAIN-2

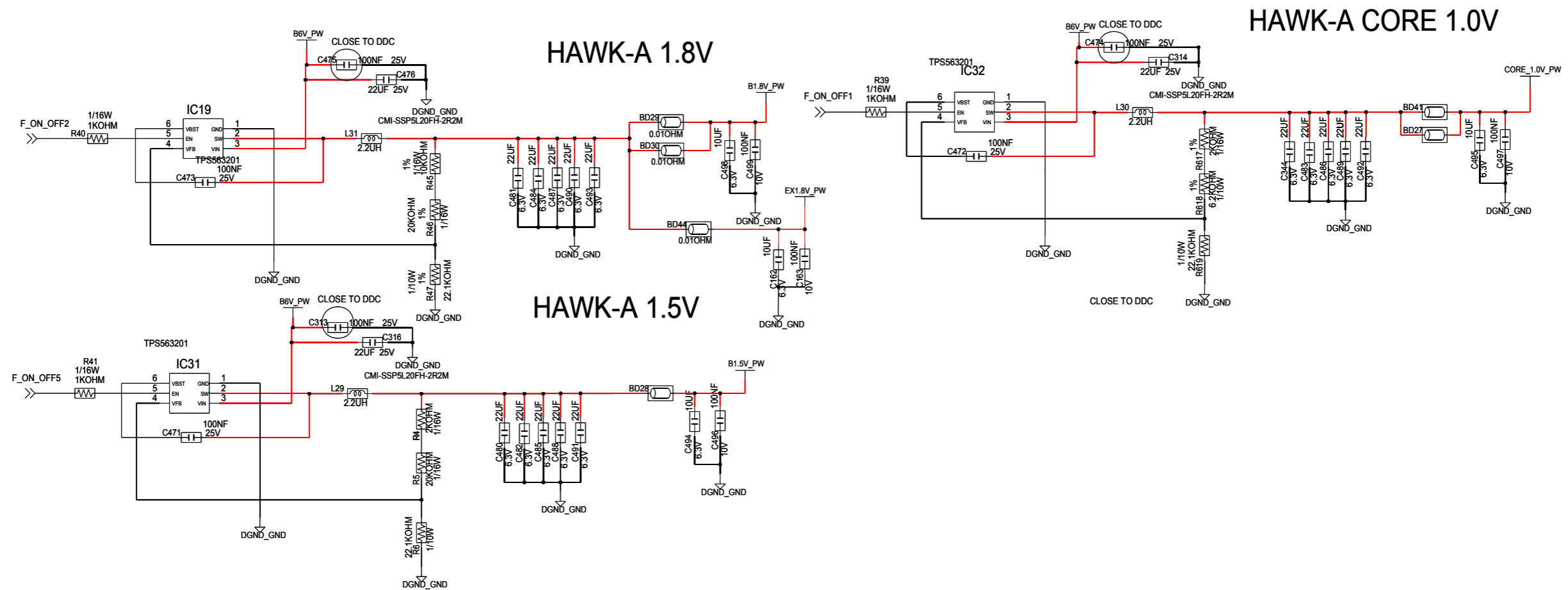

6-4. MAIN-3



MICOM 128KB

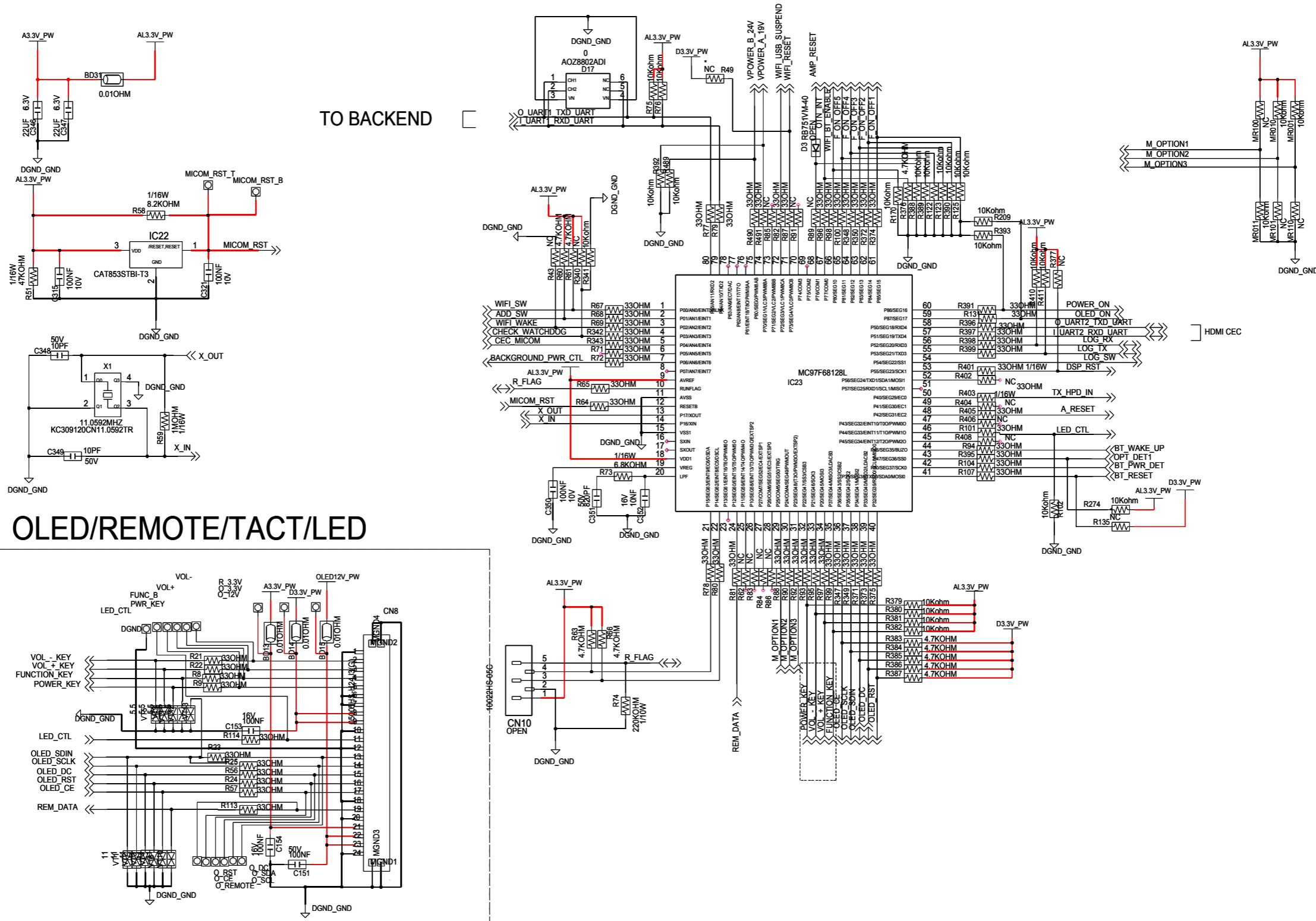

6-5. MAIN-4



HAWK-A USB

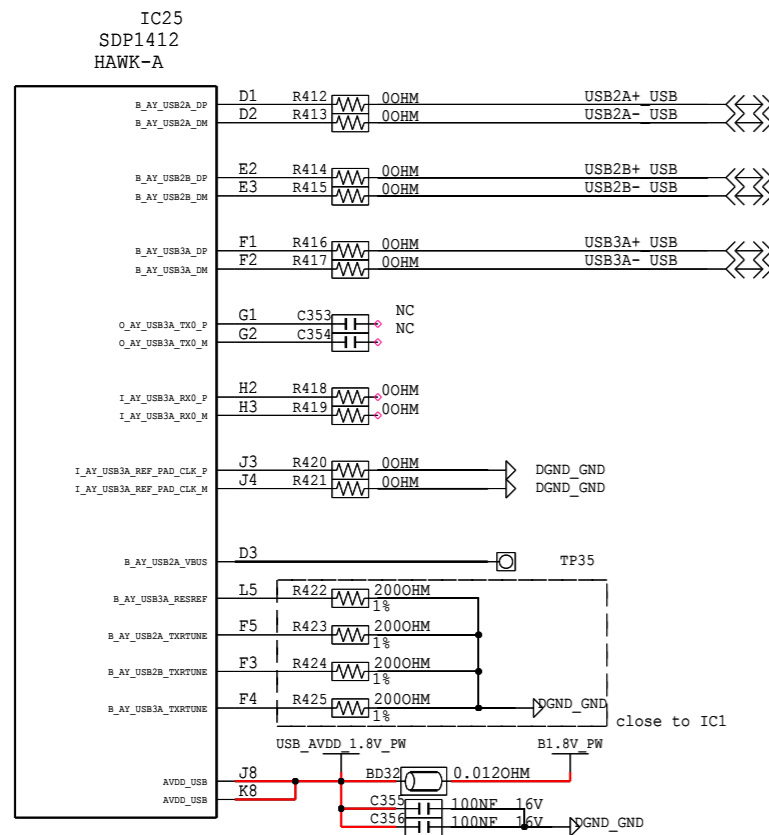

BT
REAR USB
WIFI

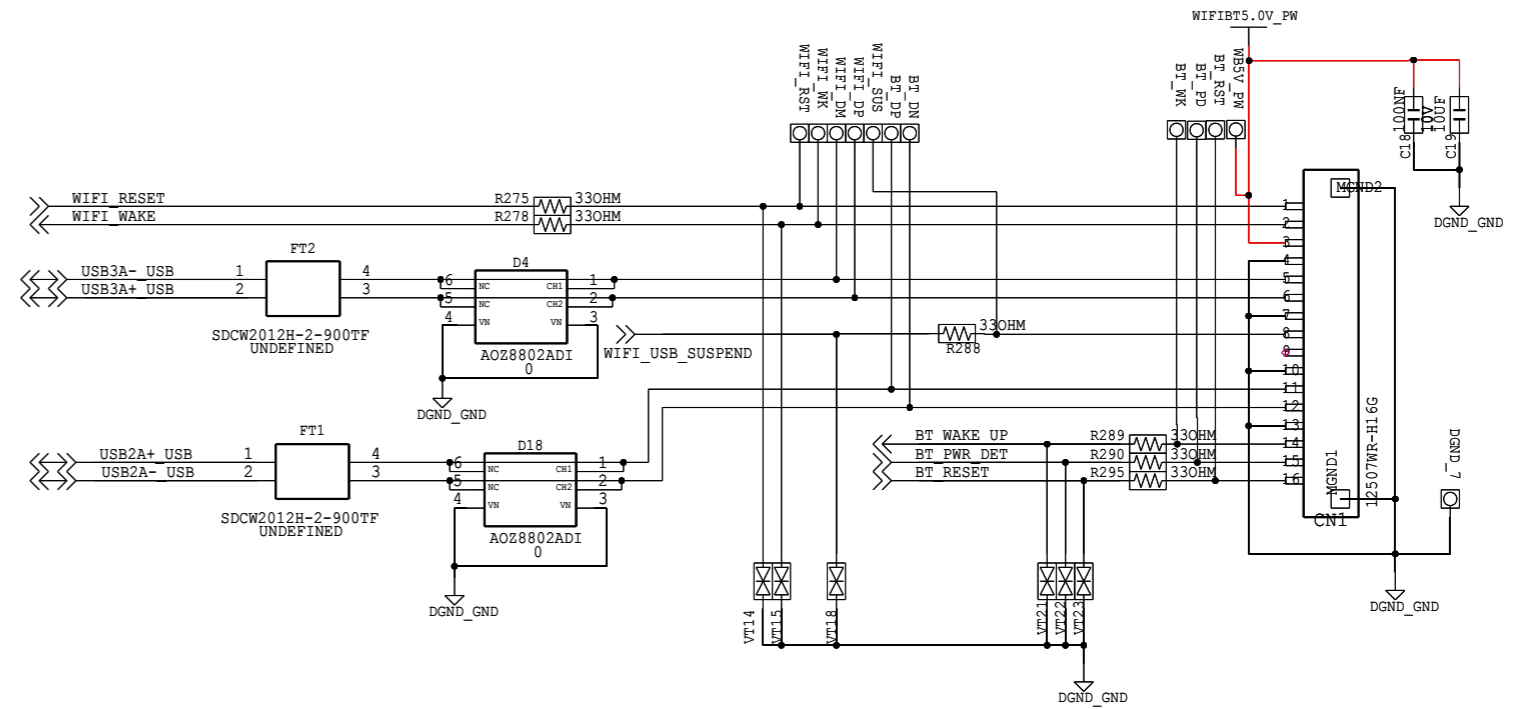
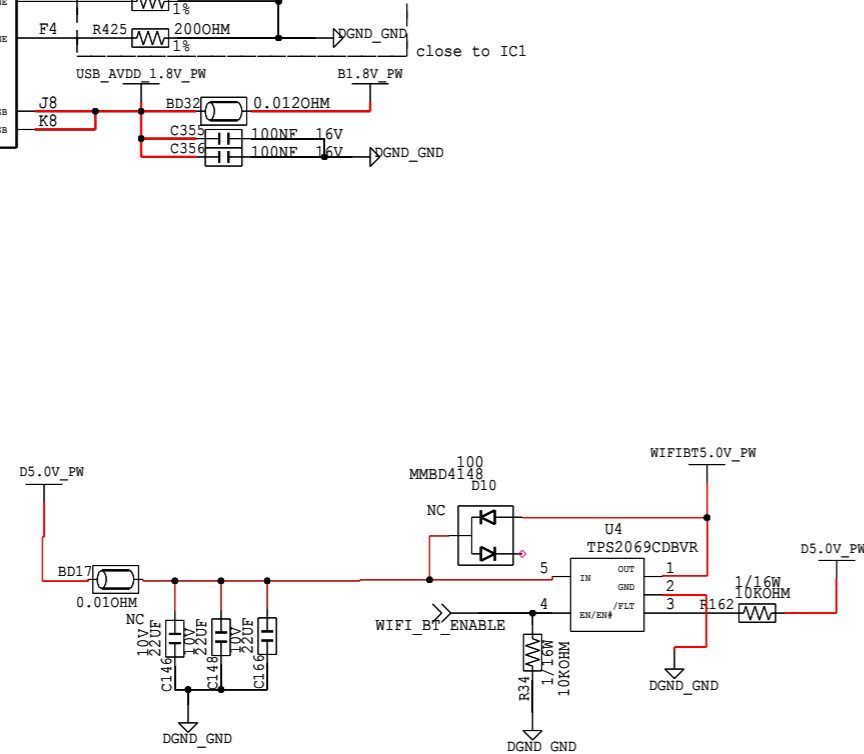
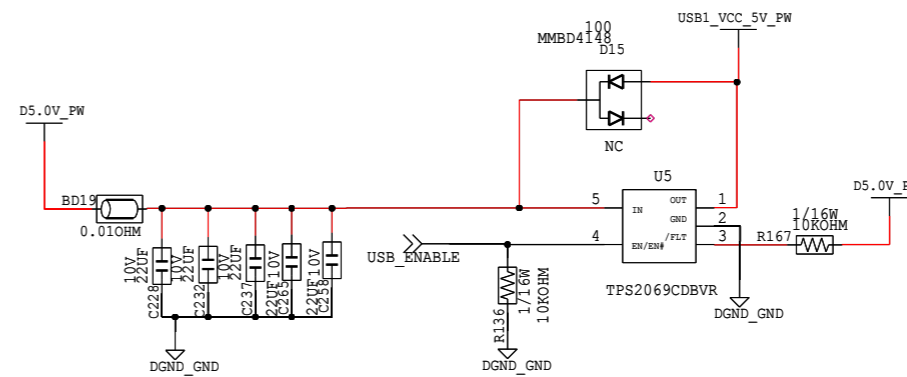
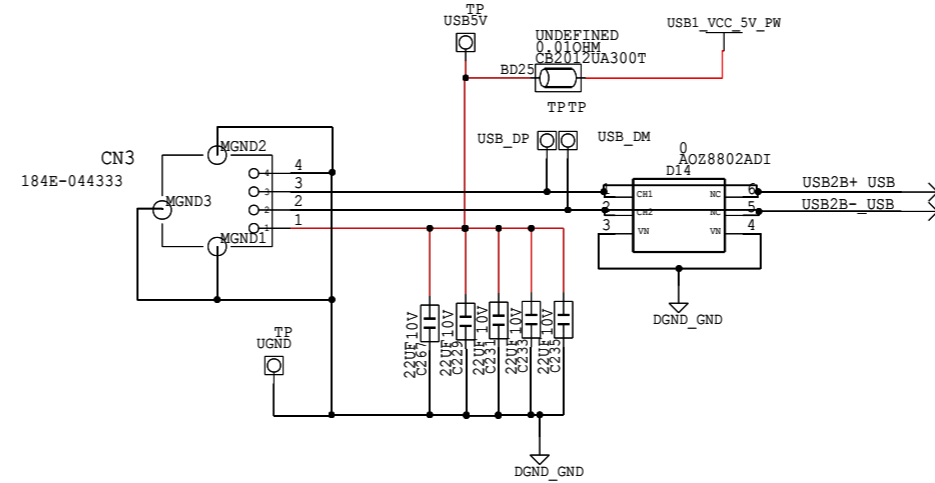

6-6. MAIN-5



HAWK-A POWER/SYSTEM

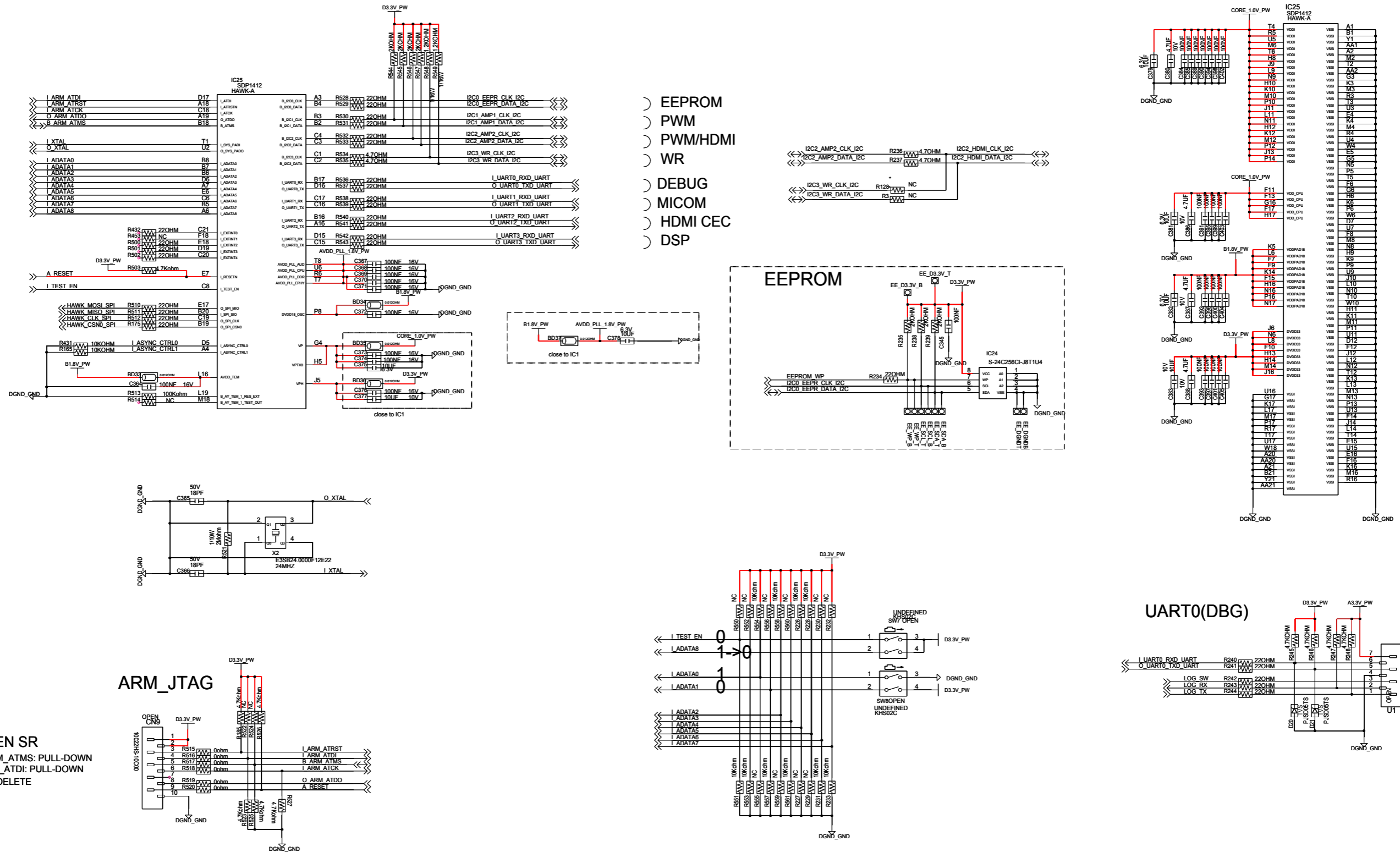

6-7. MAIN-6



HAWK-A DDR

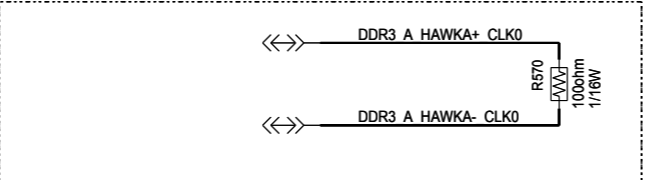
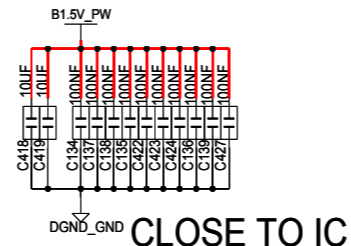
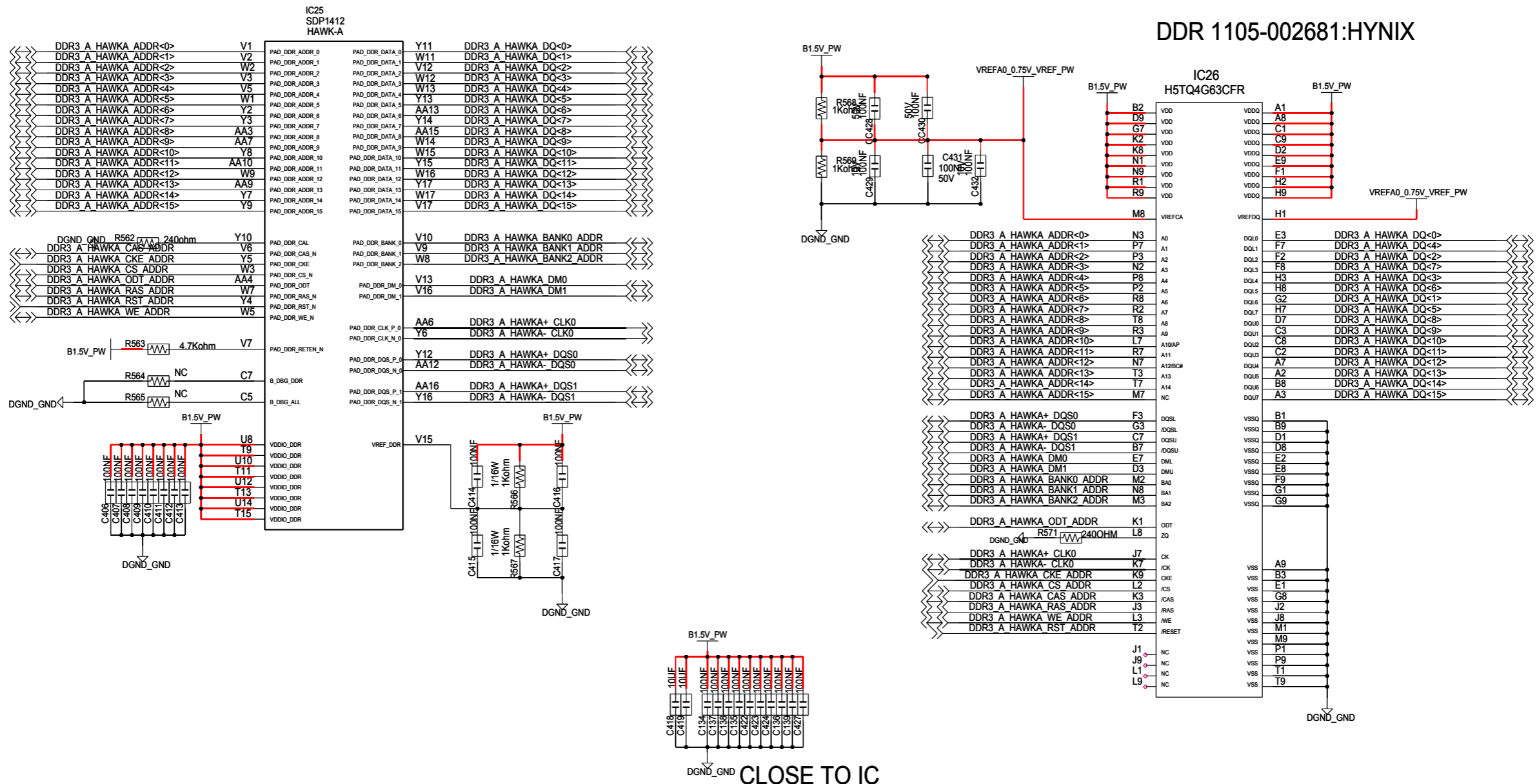

6-8. MAIN-7



HAWK-A eMMC

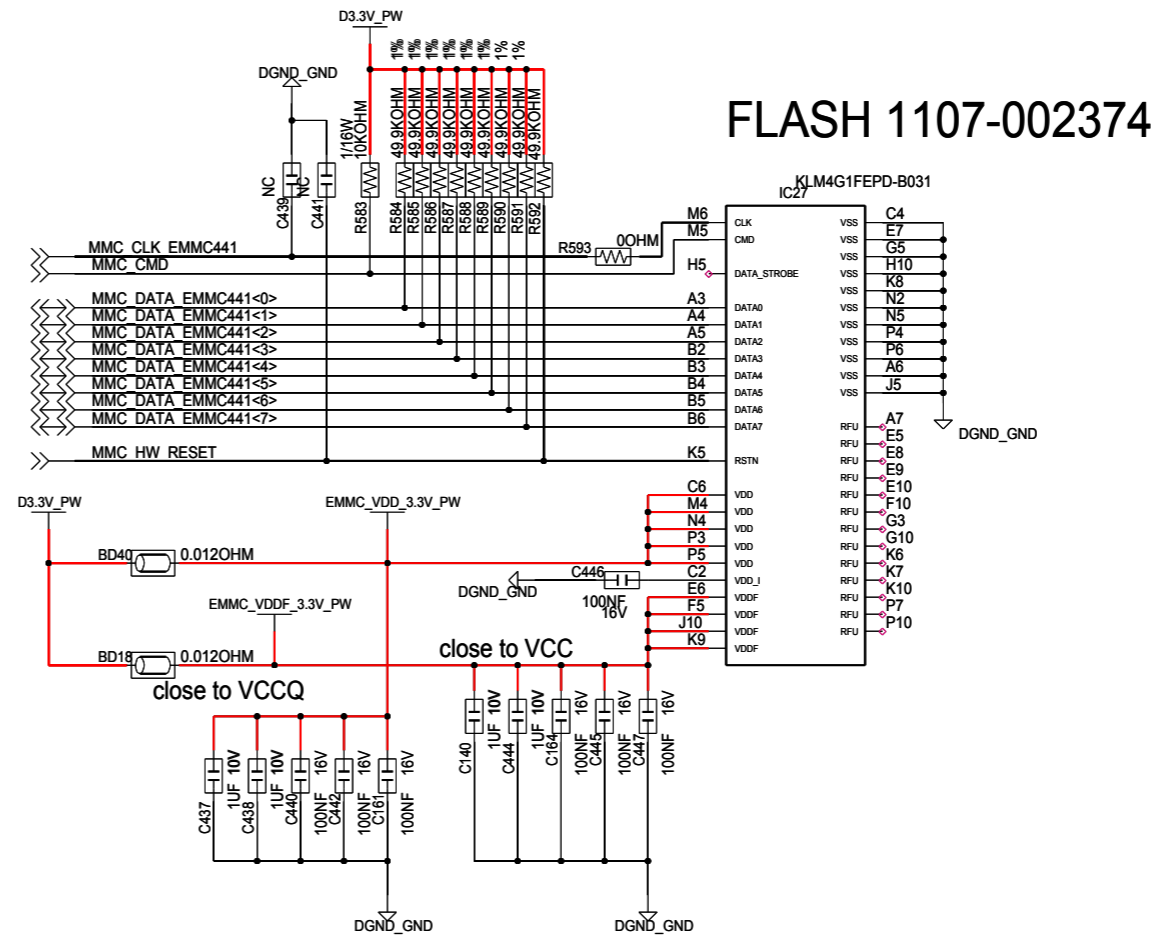
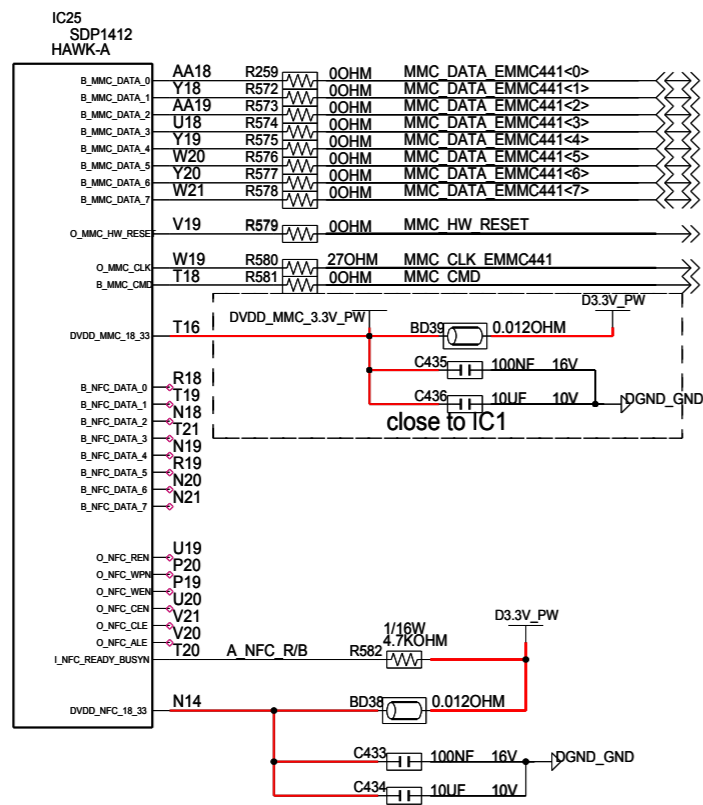

6-9. MAIN-8

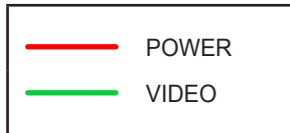

HAWK-A I2S

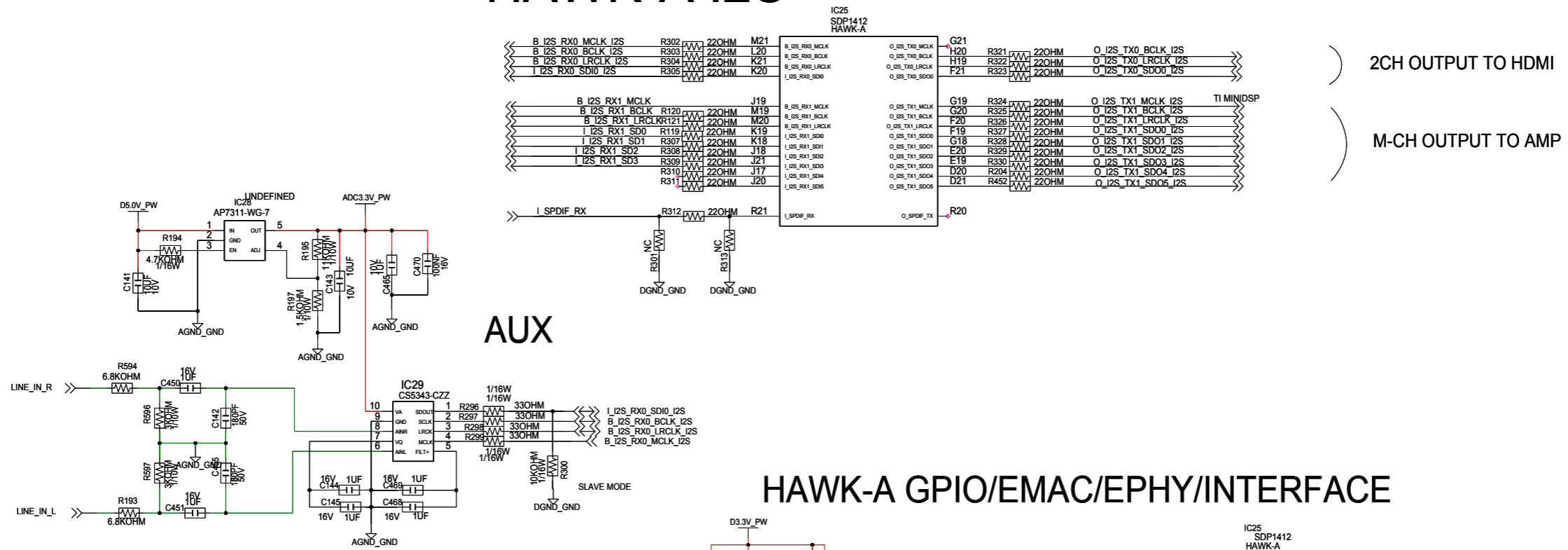

HAWK-A GPIO/EMAC/EPHY/INTERFACE

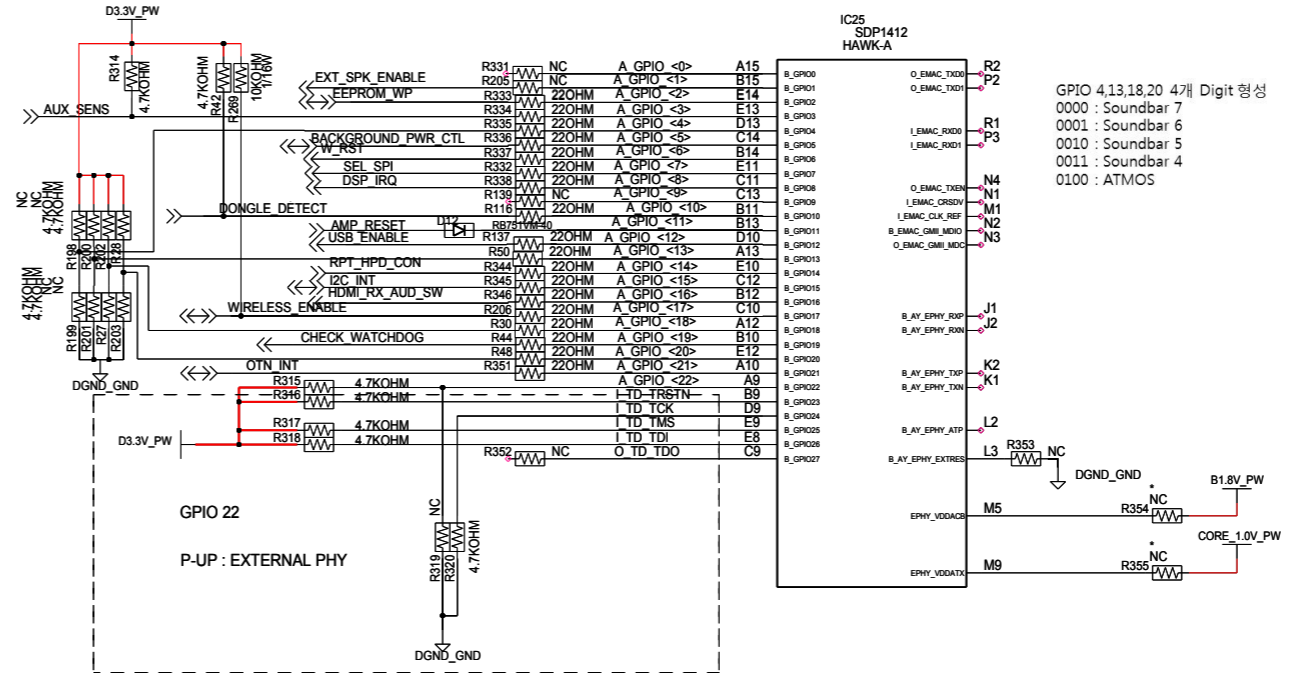

6-10. JACK



OPTICAL/AUX/USB JACK

JACK PCB

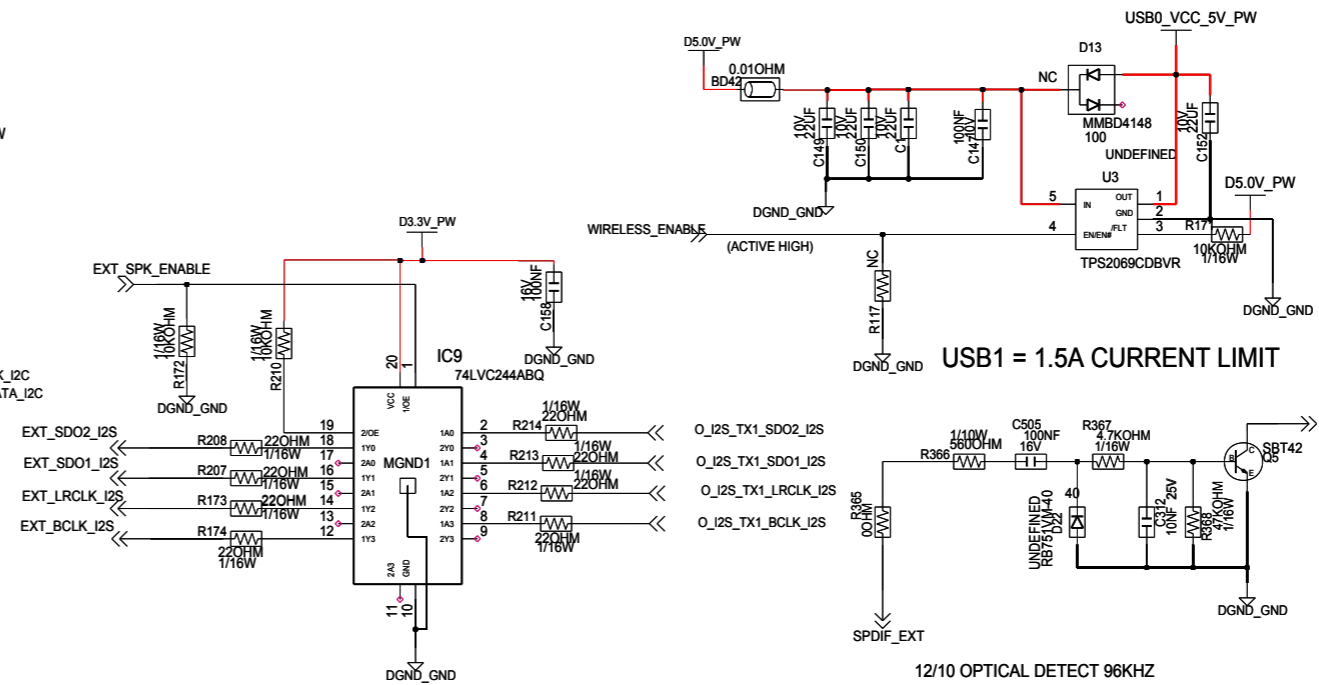
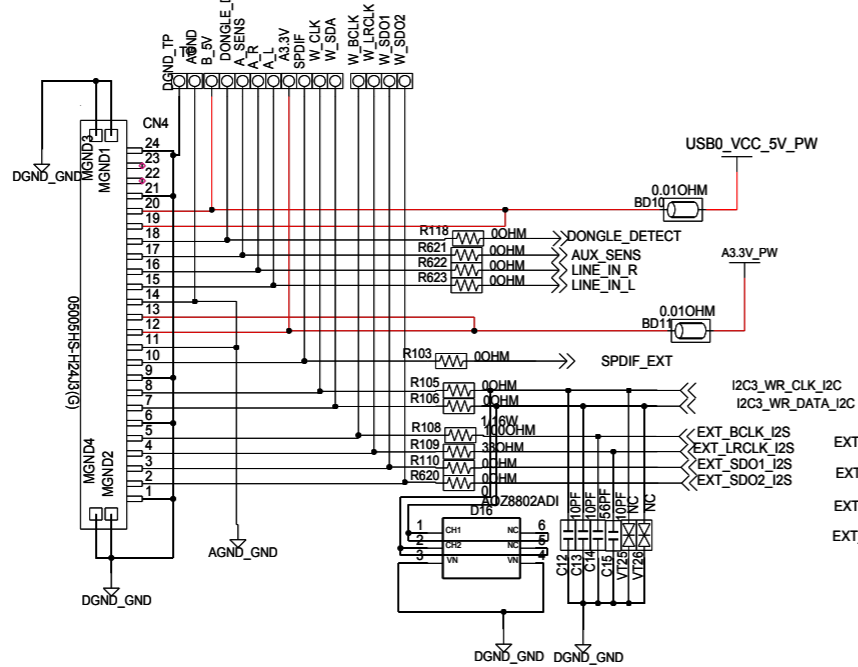

USB1 = 1.5A CURRENT LIMIT

12/10 OPTICAL DETECT 96KHZ

NETWORK TACT KEY

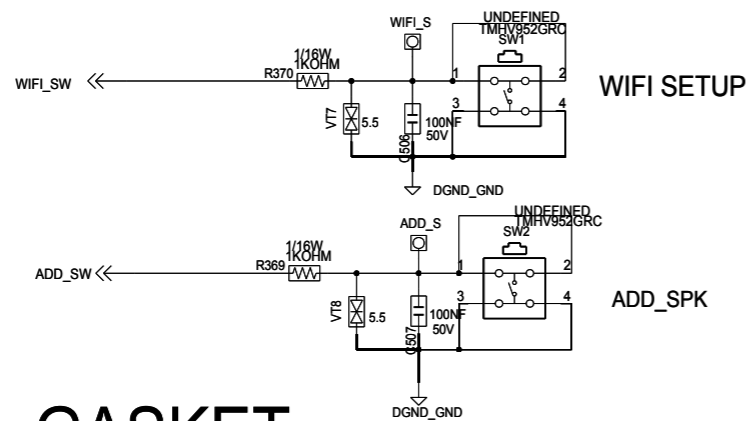

GASKET

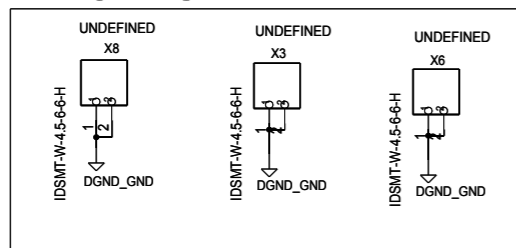

HDMI GASKET

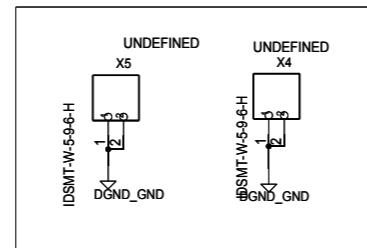

6-11.MAIN-10



DSP POWER

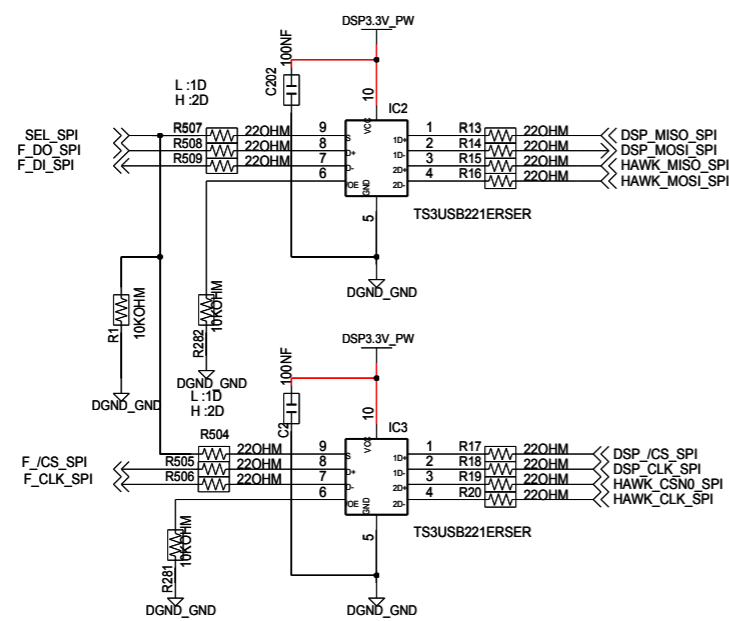
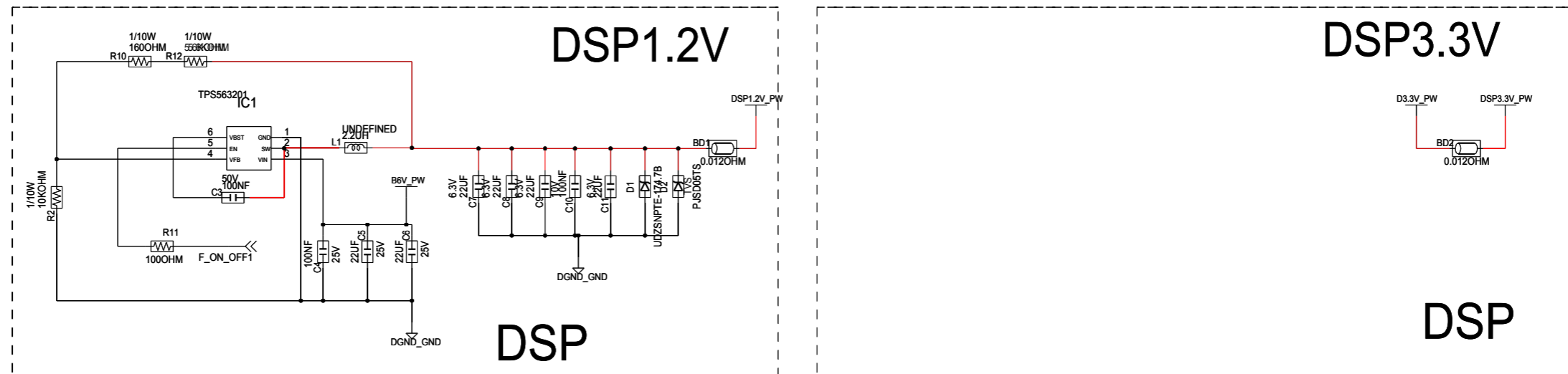

6-12. MAIN-11

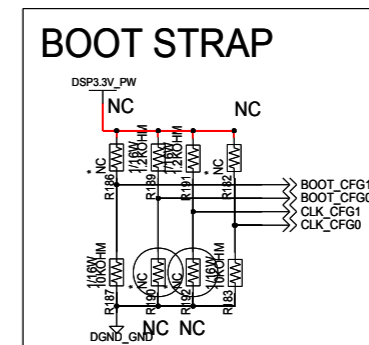
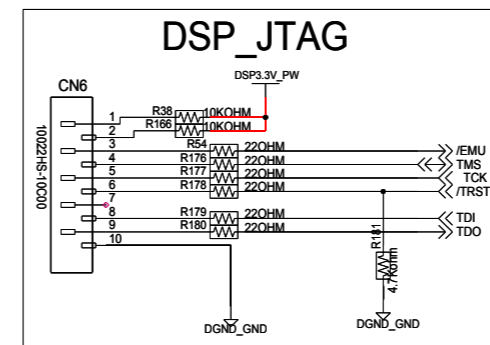
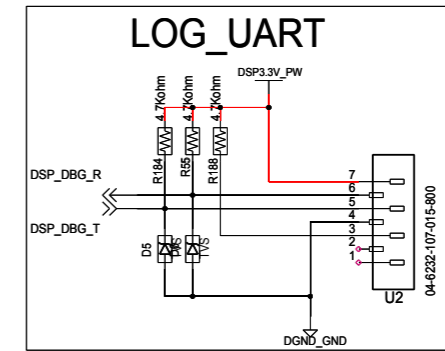
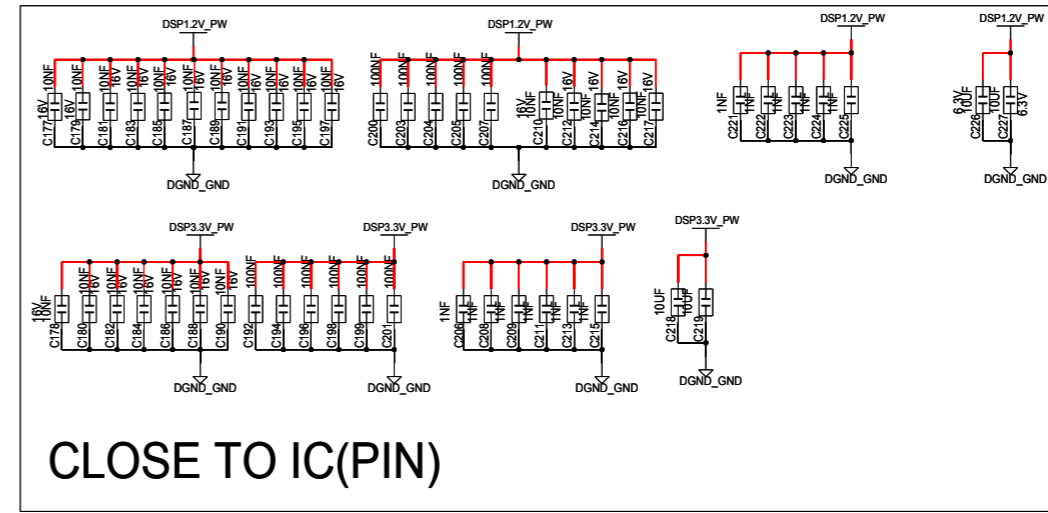
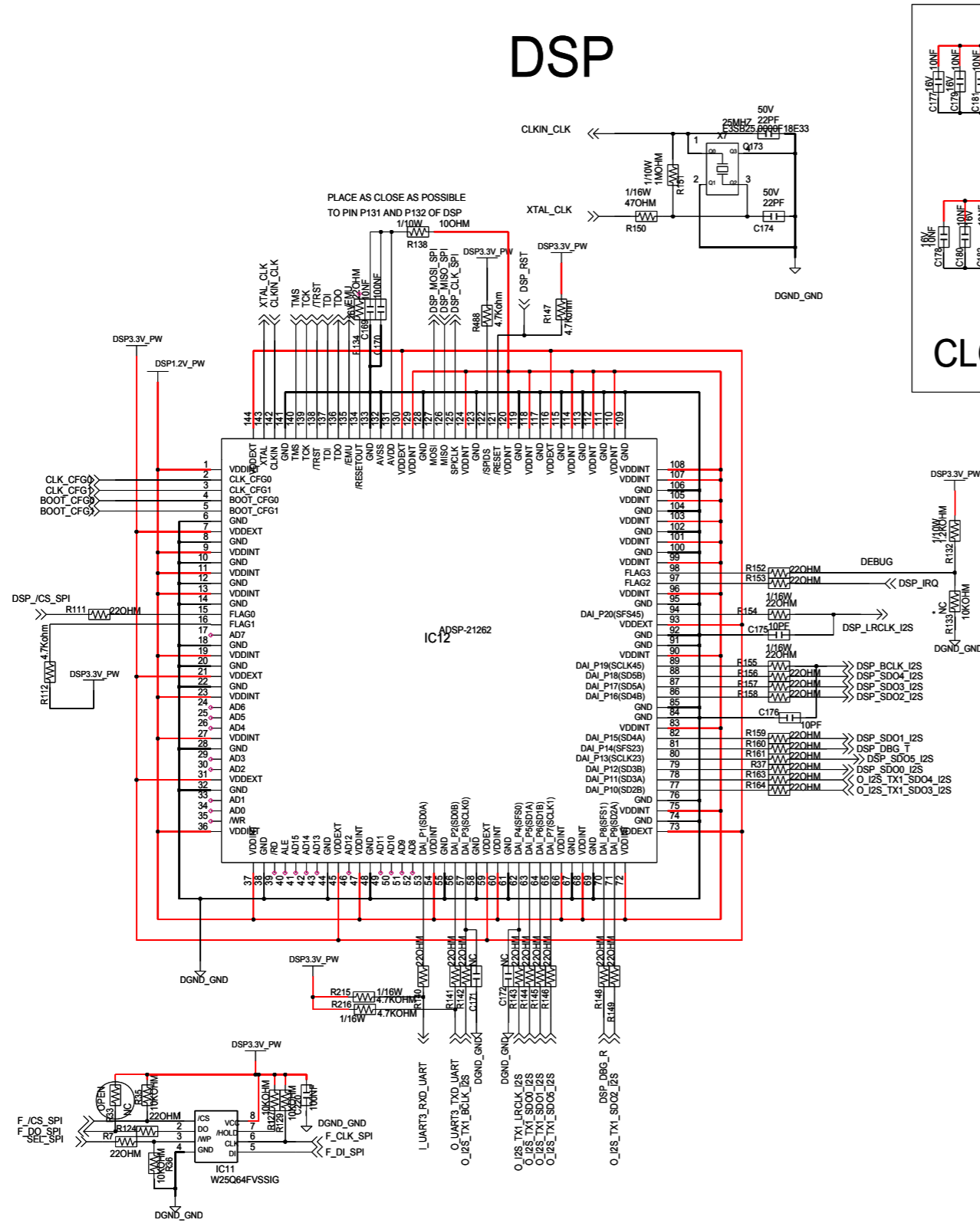

6-13. MAIN-12

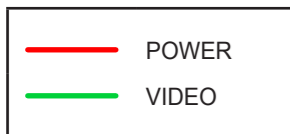

AMP FRONT MID

	ADDR0	ADDR1	WR		
FRONT MID(L/R)	HIGH	LOW	32	SDO0	I2C1
FRONT M.WOOFER(L/R)	LOW	HIGH	34	SDO1	I2C1
FRONT TW	HIGH	HIGH	36	SDO3	I2C1
*****	LOW	LOW	30	SDO5	I2C1
CENTER MID,W	HIGH	LOW	32	SDO2	I2C2
CENTER TW	LOW	HIGH	34	SDO4	I2C2
SIDE	LOW	LOW	90	SDO5	
*****	HIGH	HIGH	96	SDO*	

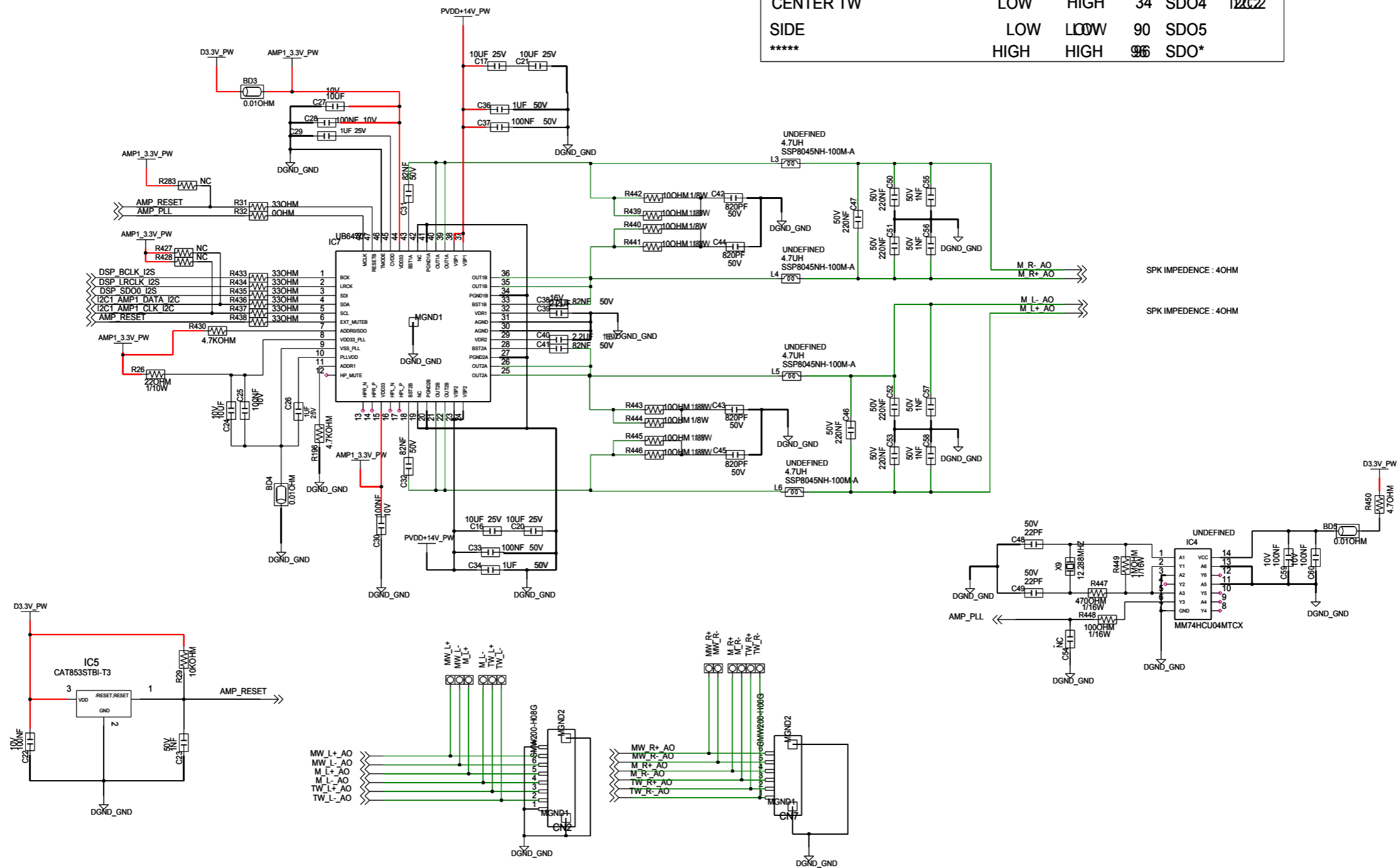

SPK IMPEDENCE : 40HM
 SPK IMPEDENCE : 40HM

6-14. MAIN-13

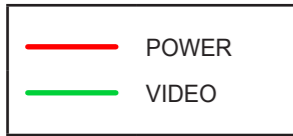

AMP FRONT M.WOOFER(L/R)

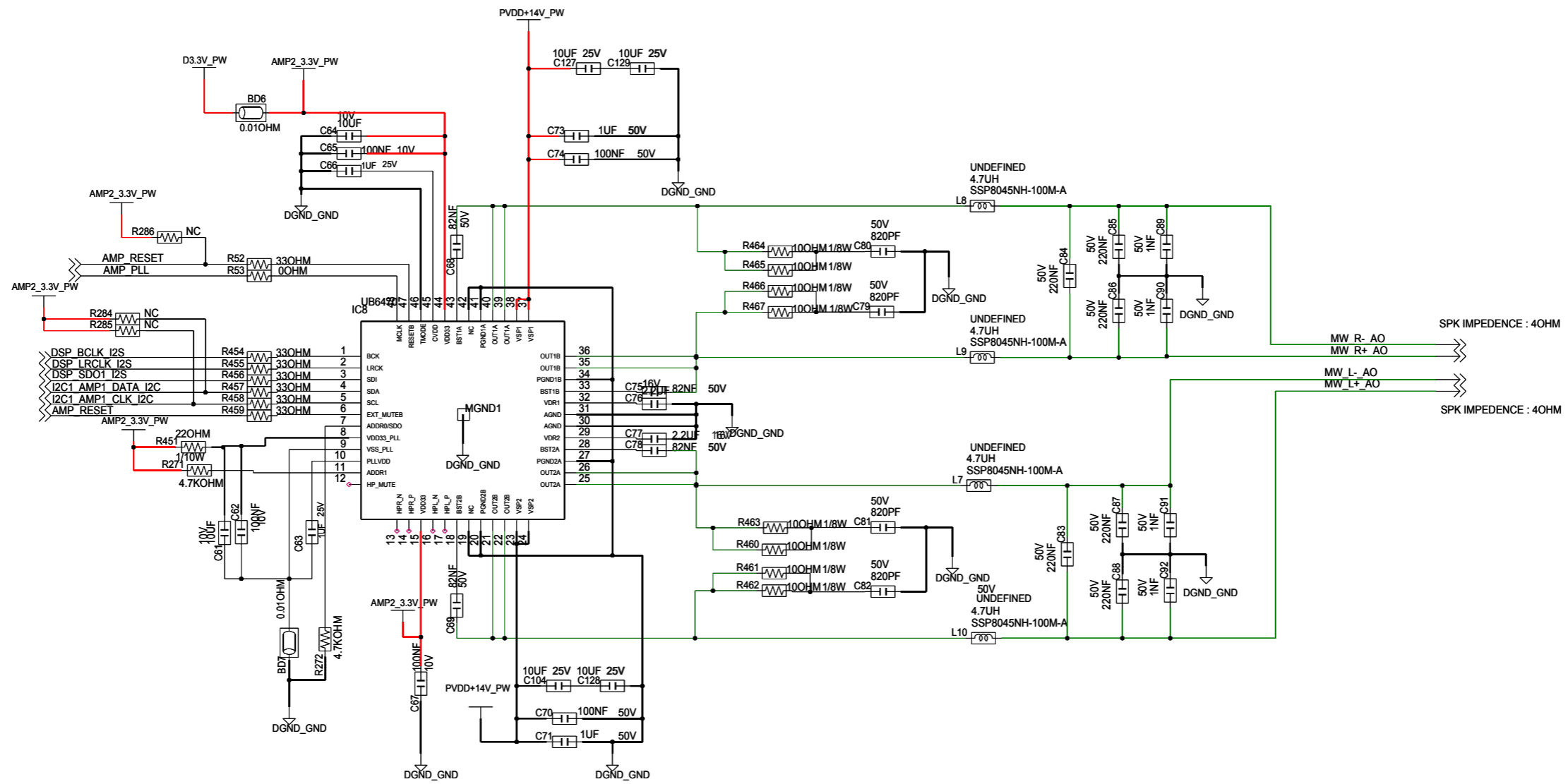

6-15. MAIN-14

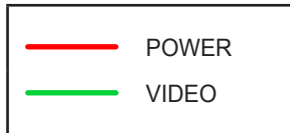

AMP FRONT TWEETER

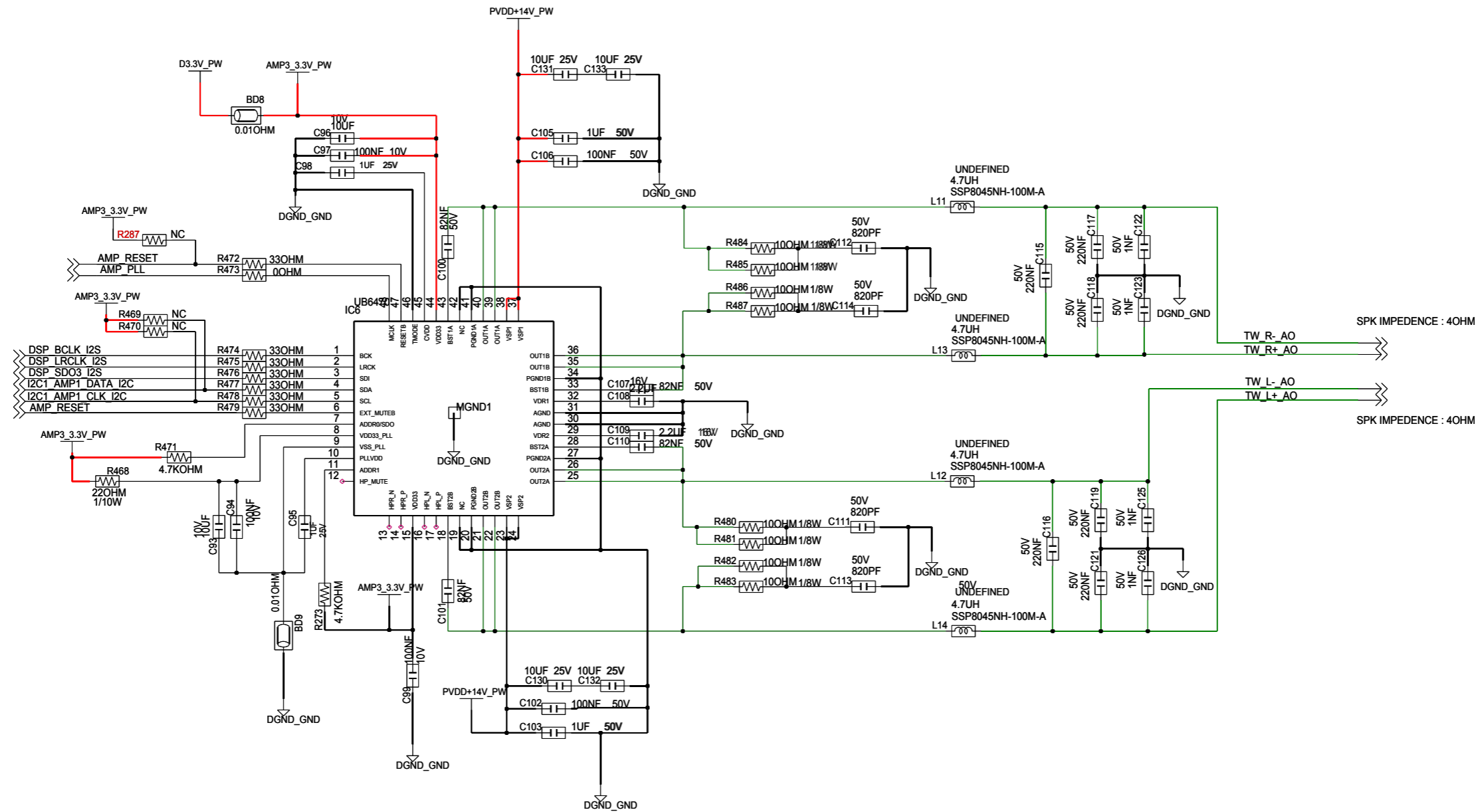

6-16. MAIN-15



HDMI_RPT

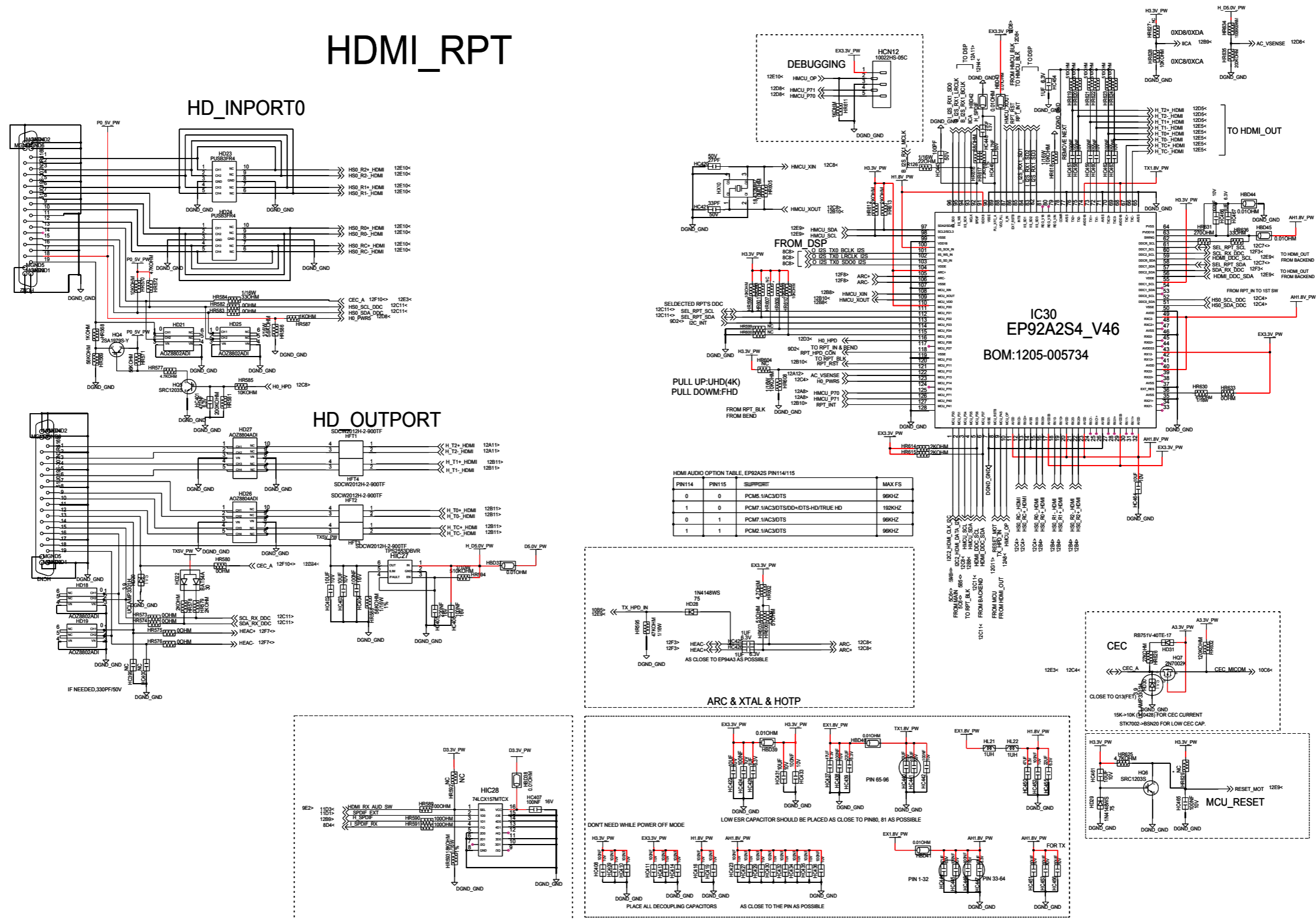

6-17. JACK

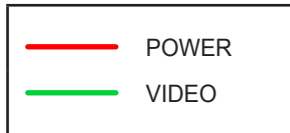

AUX/ OPTICAL/ USB-C

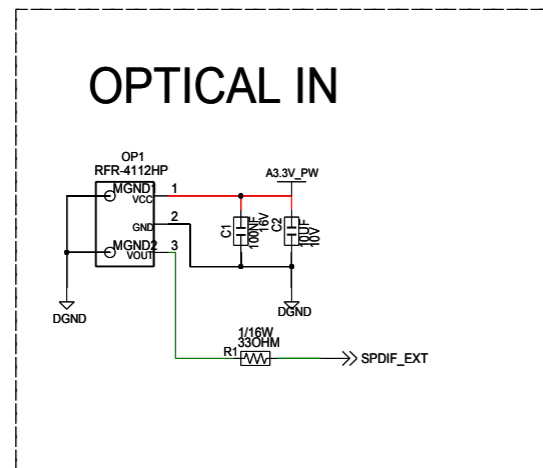

TO MAIN

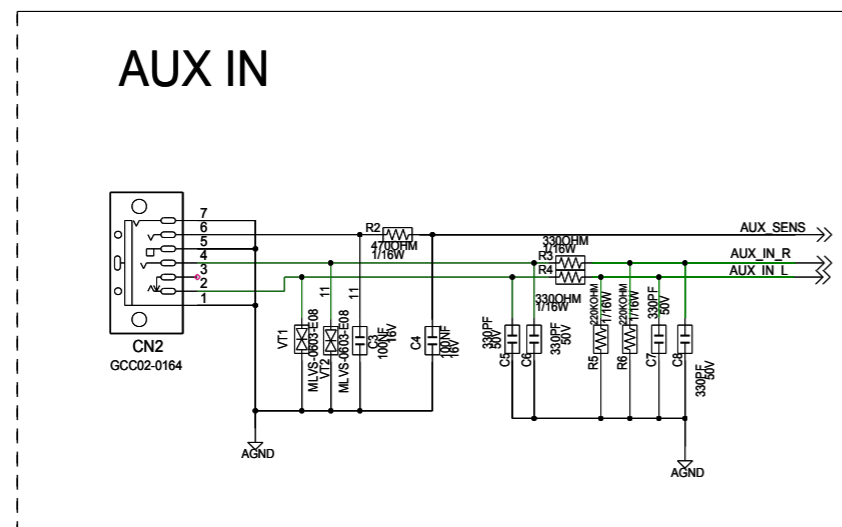
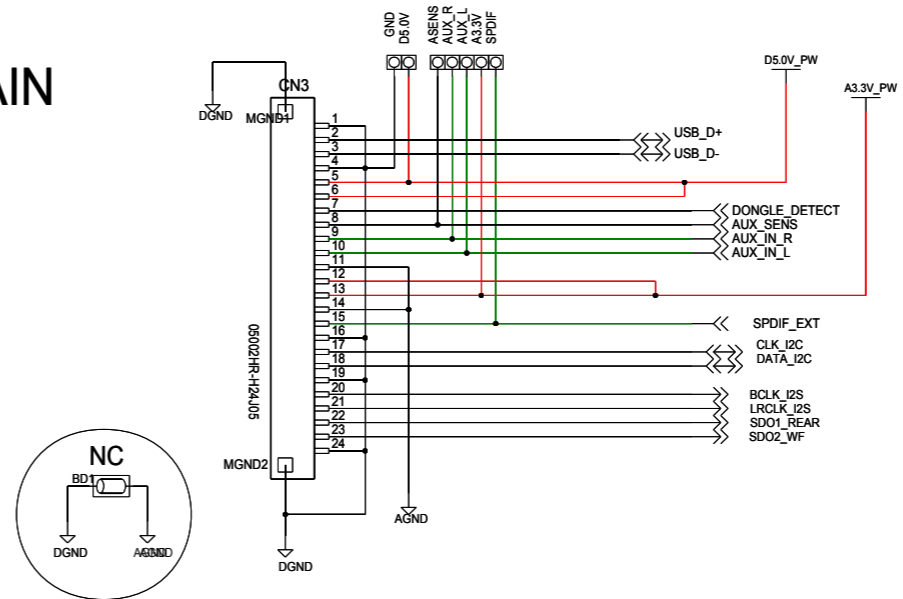

USB-C

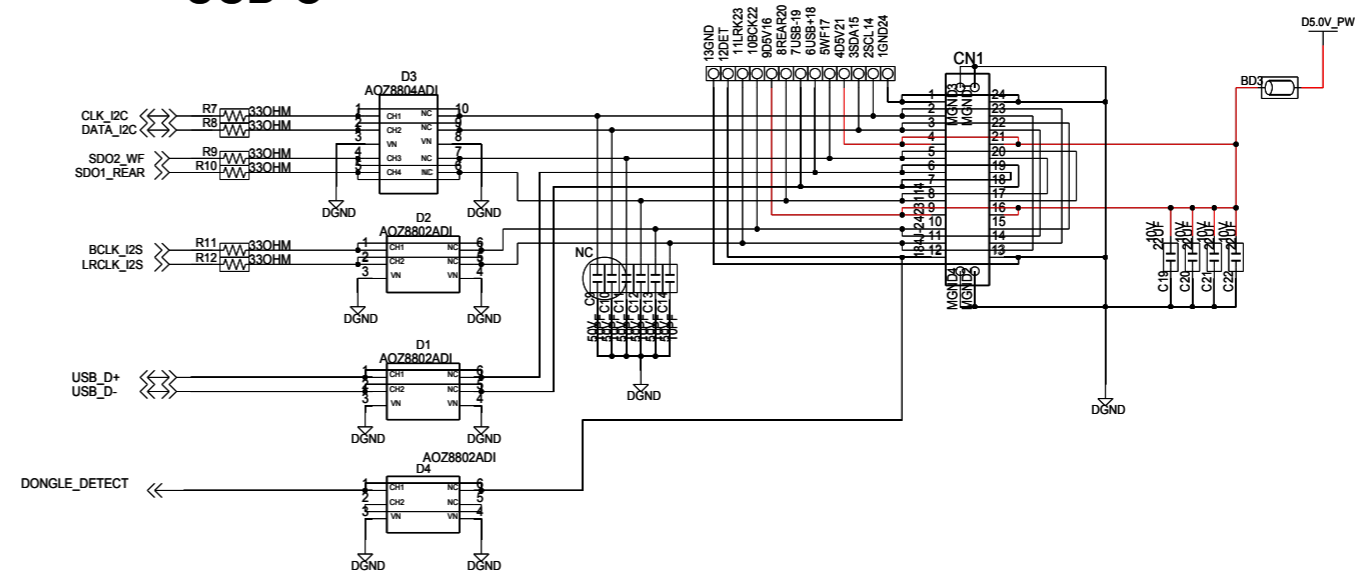

6-18. OLED KEY-1



REMO/OLED

TO KEY

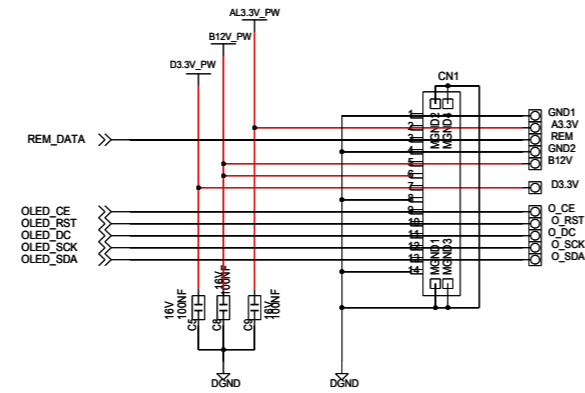

OLED

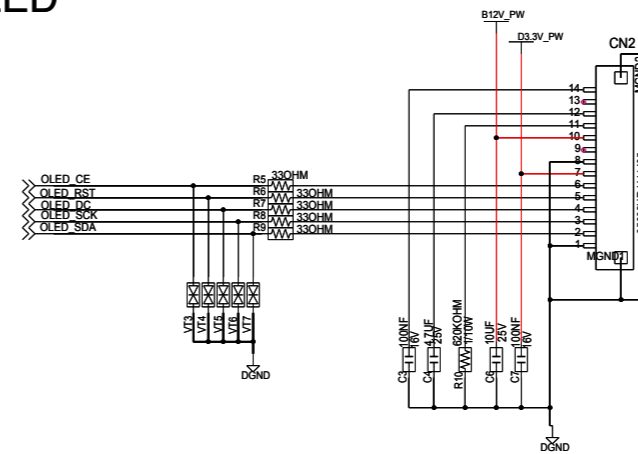

REMOTE CONTROL

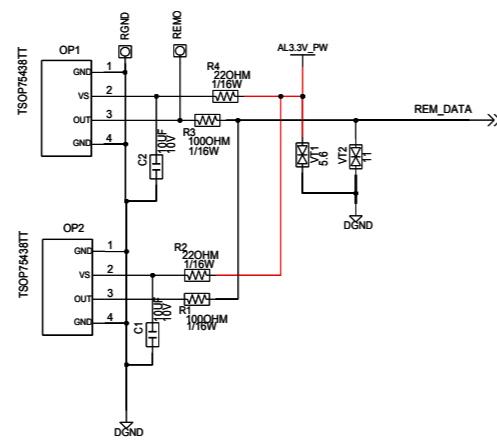

6-19. OLED KEY-2



KEY & LED

TO MAIN

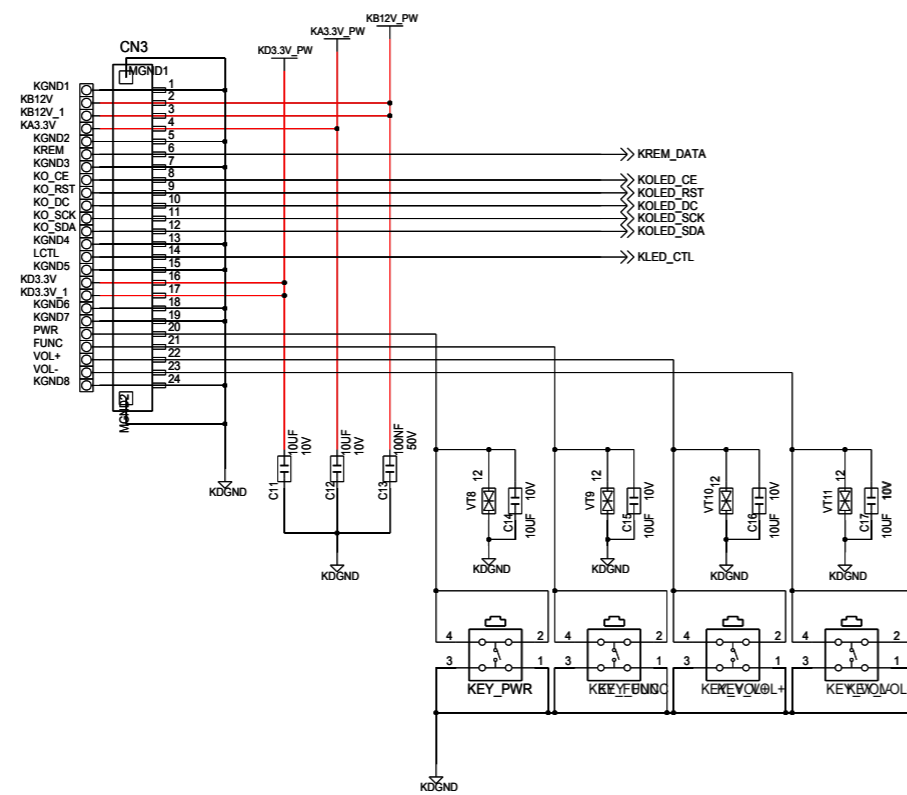

TO OLED

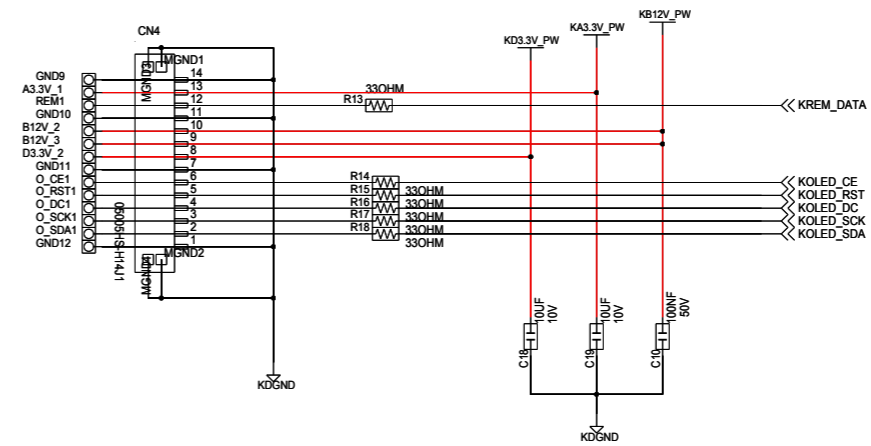

LED

